

TABLE S103.7 - UPLIFT CONNECTIONS - 140 MPH WINDS EXP "C"

WFCM 2015 TABLE 3.2.4 A.3.4

CONNECTION	FRAMING SPACING (INCHES)	ROOF SPAN (FEET)	UPLIFT	ROOF SPAN (FT)	FRAMING SPACING (INCHES)	NUMBER OF 8d COMMON NAILS OR 10d BOX NAILS IN EACH END OF 1-1/4"x20 GAUGE STRAP
ROOF ASSEMBLY TO WALL ASSEMBLY; WALL ASSEMBLY TO WALL ASSEMBLY; WALL ASSEMBLY TO FOUNDATION				24	16"	4
				24	24"	6

TABLE S103.8 - SILL OR BOTTOM PLATE TO FOUNDATION CONNECTIONS RESISTING UPLIFT LOADS - 140 MPH WIND EXP "C"

WFCM 2015 TABLE 3.2.C

BOTTOM PLATE TO FOUNDATION ANCHOR BOLT CONNECTION RESISTING UPLIFT LOADS	FOUNDATION SUPPORTING	MAXIMUM ANCHOR BOLT SPACING (INCHES)	
		8' END ZONES	INTERIOR ZONES
1 - 3 STORES		30 INCHES ON CENTER	35 INCHES ON CENTER
		NOTE: A MINIMUM OF ONE ANCHOR BOLT SHALL BE PROVIDED WITHIN 6 TO 12 INCHES OF EACH END OF EACH PLATE	

TABLE S103.9 - BOTTOM PLATE TO FOUNDATION CONNECTIONS RESISTING SHEAR & LATERAL LOADS - ALL WINDS & ALL EXPOSURES

WFCM 2015 TABLE 3.2.B

ANCHOR BOLT DIAMETER (IN)	1/2" Ø ANCHOR BOLT	5/8" Ø ANCHOR BOLT
MAXIMUM ANCHOR BOLT SPACING (INCHES)	31 INCHES	48 INCHES

TABLE S103.10 - FULL HEIGHT STUD REQUIREMENT FOR HEADERS OR WINDOW SILL PLATES IN EXTERIOR WALLS EXPOSURE B & C

WFCM 2015 TABLE 3.23C

HEADER SPAN (FEET)	WALL SPACING (INCHES)		
	12" O.C.	16" O.C.	24" O.C.
NUMBER OF FULL HEIGHT STUD REQUIRED AT EACH END OF THE HEADER			
2	1	1	1
4	2	2	1
6	3	3	2
8	4	3	2

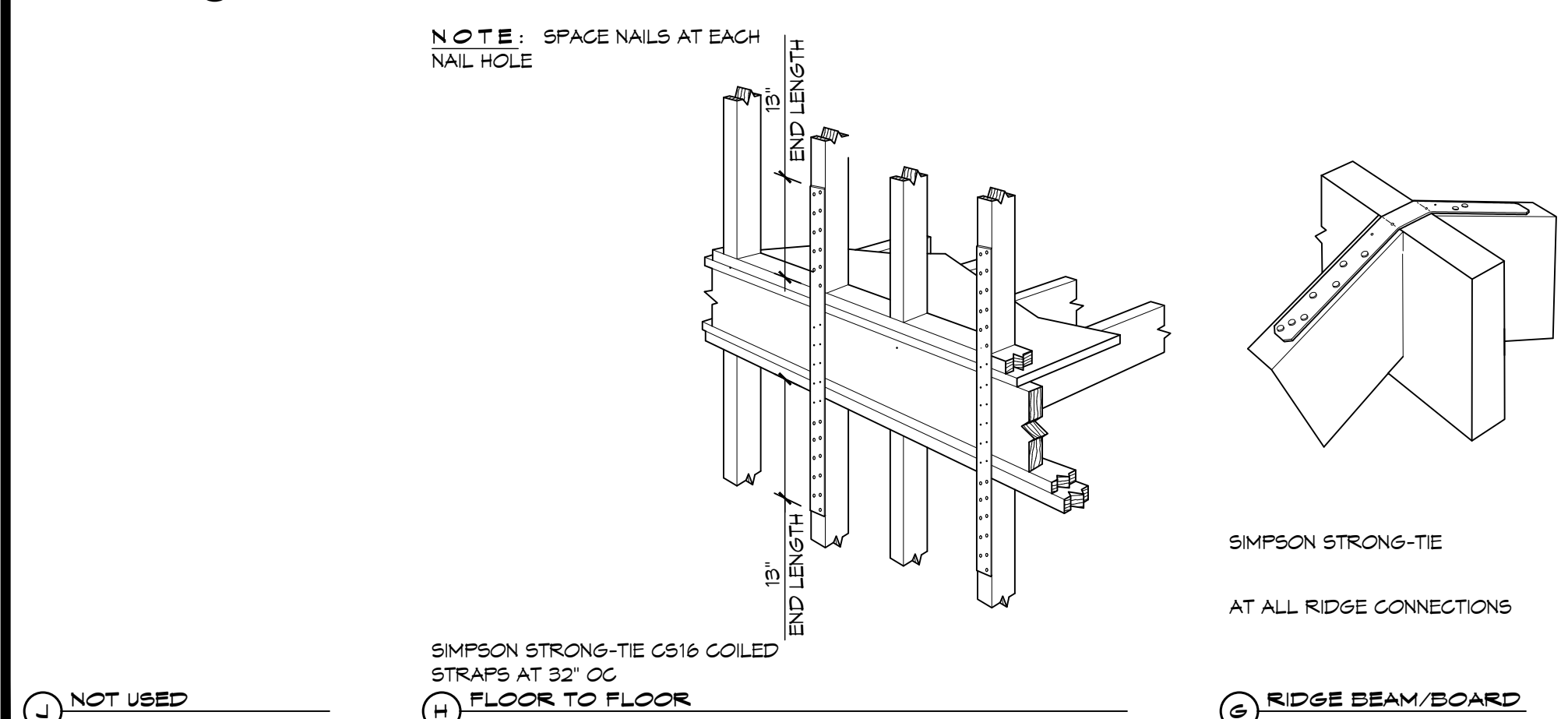
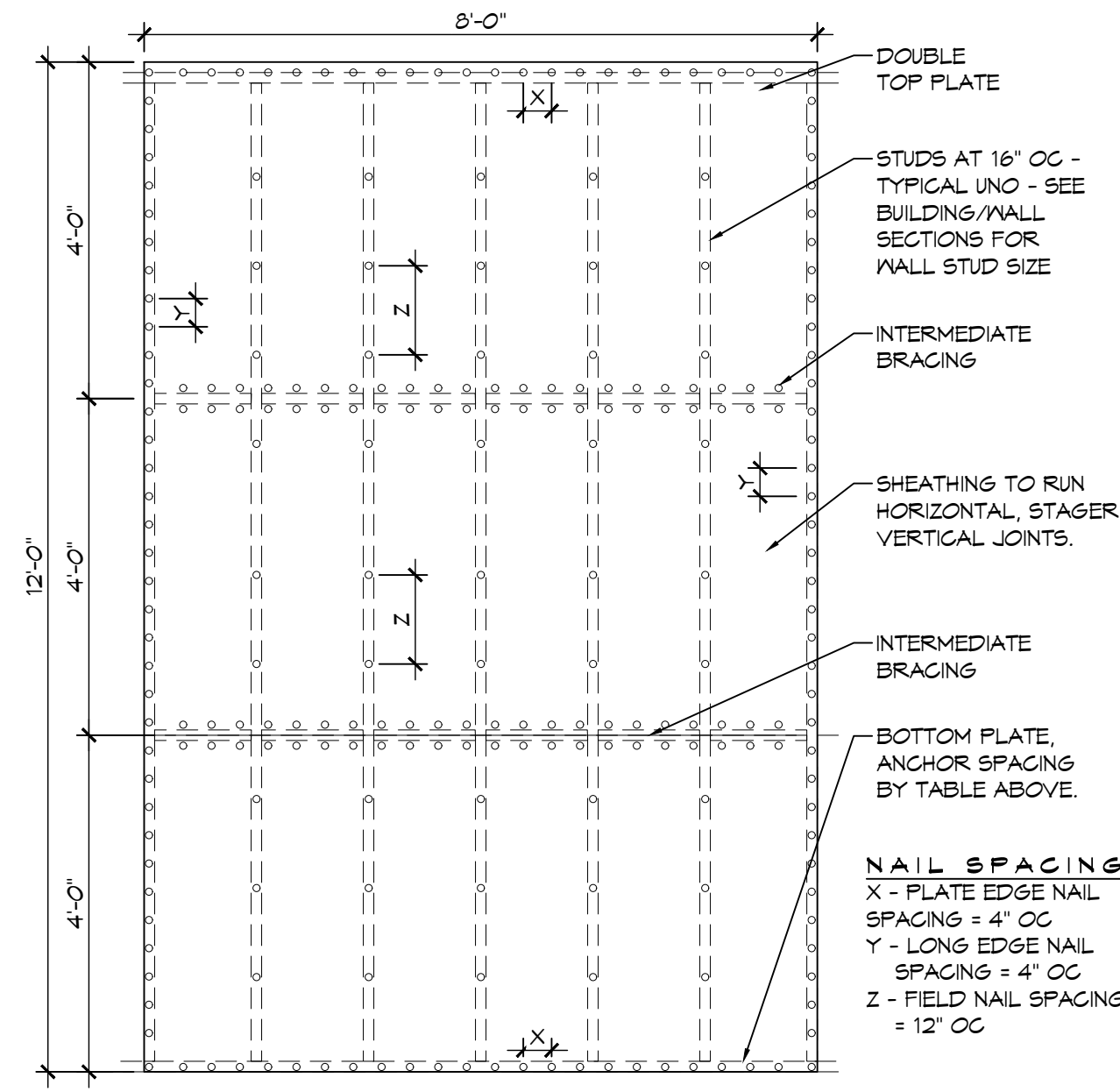

6 TYPICAL CONNECTION DETAILS

TABLE S103.5 - JACK STUD REQ - INT LOADBEARING WALLS

HEADER SUPPORTING	HEADER SPAN (FT)	ROOF SPAN (FEET)											
		12 FEET				24 FEET				36 FEET			
		3"	4.5"	5"	6.5"	3"	4.5"	5"	6.5"	3"	4.5"	5"	6"
NUMBER OF JACK STUDS REQUIRED AT EACH END OF THE HEADER													
ONE FLOOR ONLY (CENTER BEARING)	2	1	1	1	1	1	1	1	1	1	1	1	1
	4	1	1	1	1	1	1	1	1	1	1	1	1
	6	1	1	1	1	1	1	1	1	2	1	1	1
	8	1	1	1	1	2	1	1	1	2	2	2	1
	10	1	1	1	1	2	2	1	1	3	2	2	2
	12	1	1	1	1	2	2	2	1	3	2	2	2
TWO FLOORS (CENTER BEARING)	2	1	1	1	1	1	1	1	1	2	1	1	1
	4	1	1	1	1	2	1	1	3	2	2	2	2
	6	2	1	1	1	3	2	2	2	4	3	2	2
	8	2	2	1	1	3	2	2	2	5	3	3	3
	10	2	2	2	1	4	3	3	2	6	4	4	3
	12	3	2	2	2	5	3	3	3	7	5	4	4
	14	3	2	2	2	6	4	4	3	8	5	5	4
	16	4	3	2	2	6	4	4	3	9	6	6	5

TABLE S103.6 - JACK STUD REQ - EXTERIOR LOADBEARING WALLS

WFCM 2015 TABLE 3.22F

ROOF AND CEILING	HEADER SPAN (FEET)	ROOF LIVE LOAD 20 PSF								
		3"				4.5"				
		3"	4.5"	5"	6.5"	3"	4.5"	5"	6.5"	
NUMBER OF JACK STUDS REQUIRED										
ROOF AND CEILING	2	1	1	1	1	1	1	1	1	1
	4	1	1	1	1	1	1	1	1	1
	6	2	1	1	1	2	1	1	1	1
	8	2	2	2	1	2	2	2	1	1
	10	3	2	2	2	3	2	2	2	2
	12	3	2	2	2	3	2	2	2	2
ROOF, CEILING, AND ONE CENTER BEARING FLOOR	2	1	1	1	1	1	1	1	1	1
	4	2	1	1	1	2	1	1	1	1
	6	2	2	2	1	3	2	2	2	2
	8	3	2	2	2	3	2	2	2	2
	10	4	3	2	2	4	3	3	2	2
	12	4	3	3	2	5	3	3	3	3
	14	5	4	3	3	5	4	3	3	3
	16	6	4	4	3	6	4	4	3	3

HEADER WIDTH - 3" (2-2x), 4.5" (3-2x), 5", 6.5" (4-2x) EACH 1/4" 1/2" PLYWOOD SPACER BETWEEN

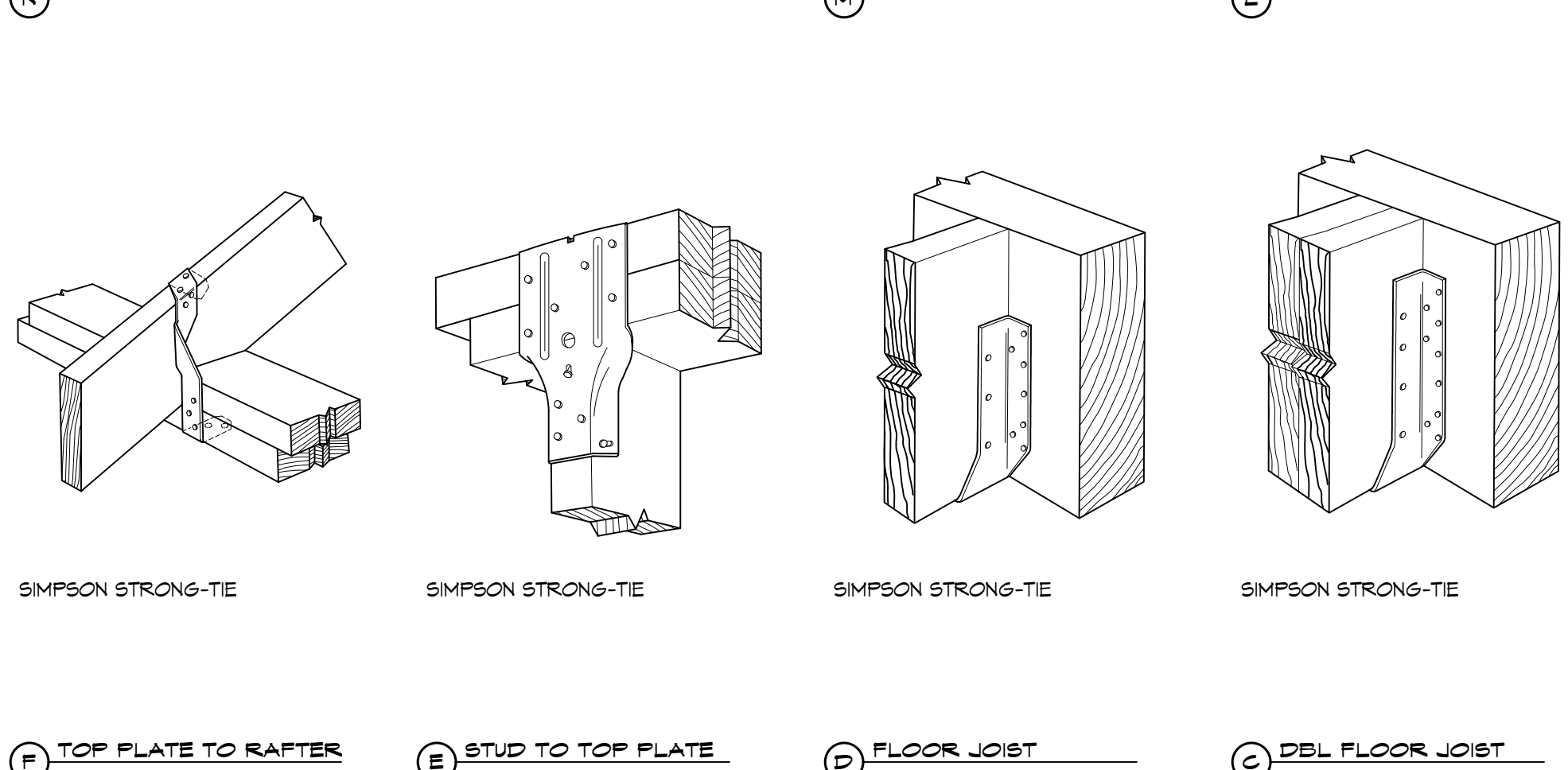
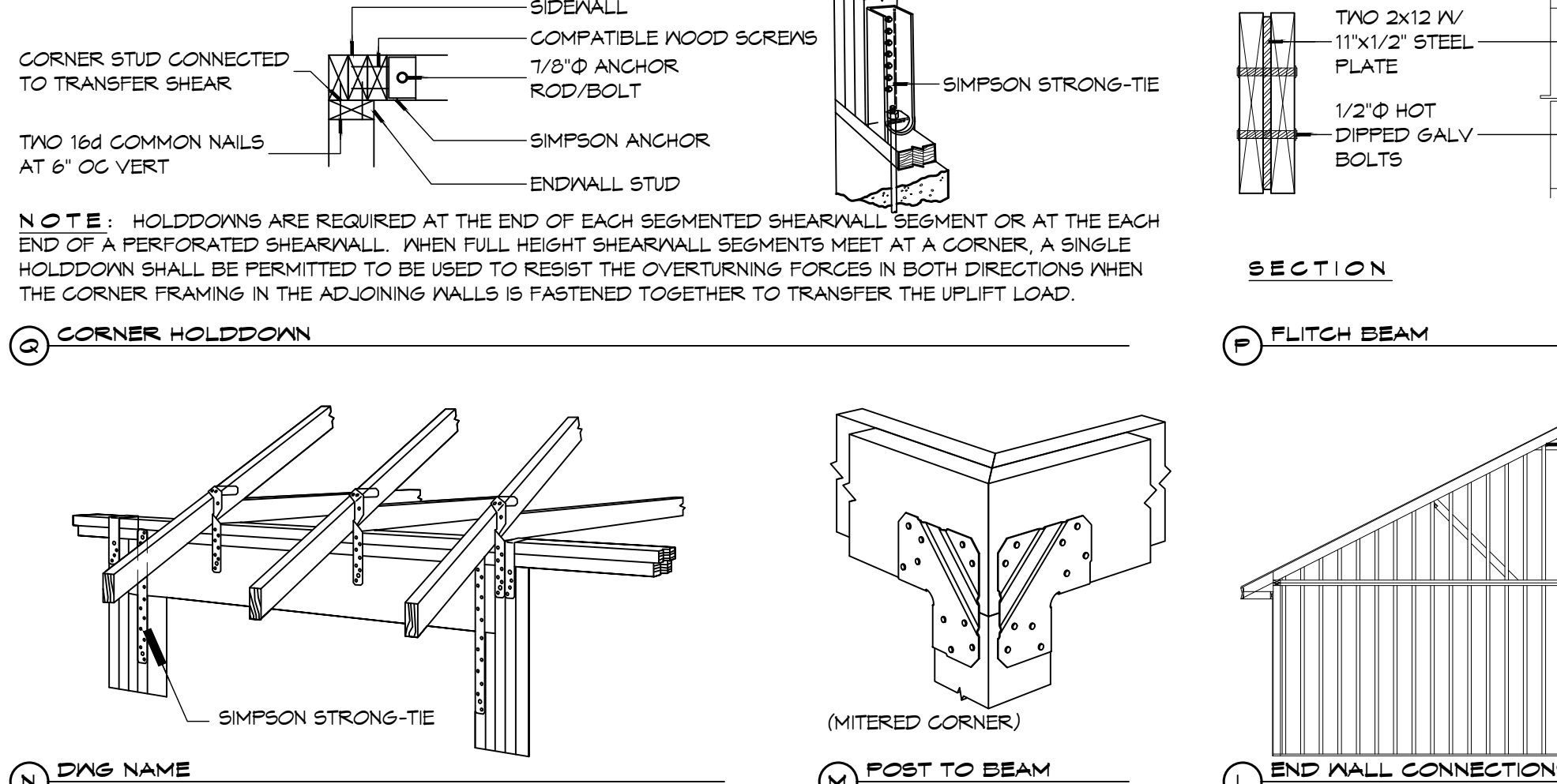

6 TYPICAL CONNECTION DETAILS

TABLE S103.3 - NAILING SCHEDULE WFCM 2015 TABLE 3.1

DESCRIPTION	NUMBER OF COMMON NAILS	NUMBER OF BOX NAILS	SPACING
HEADER TO HEADER (FACE NAILED)	16d	16d	16" OC EDGES

TABLE S103.4 - BUILDING ENVELOPE REQUIREMENTS

ROOFS	OPAQUE ELEMENTS		ASSEMBLY MAXIMUM	INSULATION MIN. R-VALUE
	INSULATION ENTIRELY ABOVE DECK	METAL BUILDING		
ROOFS	METAL BUILDING	U-0.065	R-19	
	ATTIC AND OTHER	U-0.027	R-30	
	MASS	U-0.151	R-5.7 c.i.	
WALLS, ABOVE GRADE	METAL BUILDING	U-0.113	R-13.0	
	STEEL-FRAMED	U-0.124	R-13.0	
	WOOD-FRAMED AND OTHER	U-0.089	R-13.0	
FLOORS	MASS	U-0.107	R-6.3 c.i.	
	STEEL JOIST	U-0.052	R-19.0	
	WOOD FRAMED AND OTHER	U-0.051	R-19.0	
SLAB-ON-GRADE	UN-HEATED	F-0.730	NR	
OPAQUE DOORS	SWINGING	U-0.700	NR	
	NON-SWINGING	U-1.450	NR	

TABLE S103.4 - BUILDING ENVELOPE REQUIREMENTS

ROOFS	OPAQUE ELEMENTS		ASSEMBLY MAXIMUM	INSULATION MIN. R-VALUE
	INSULATION ENTIRELY ABOVE DECK	METAL BUILDING		
ROOFS	METAL BUILDING	U-0.065	R-19	
	ATTIC AND OTHER	U-0.027	R-30	
	MASS	U-0.151	R-5.7 c.i.	
WALLS, ABOVE GRADE	METAL BUILDING	U-0.113	R-13.0	
	STEEL-FRAMED	U-0.124	R-13.0	
	WOOD-FRAMED AND OTHER	U-0.089	R-13.0	
FLOORS	MASS	U-0.107	R-6.3 c.i.	
	STEEL JOIST	U-0.052	R-19.0	
	WOOD FRAMED AND OTHER	U-0.051	R-19.0	
SLAB-ON-GRADE	UN-HEATED	F-0.730	NR	
OPAQUE DOORS	SWINGING	U-0.700	NR	
	NON-SWINGING	U-1.450	NR	

ROOF UNDERLAYMENT NOTES

- FOR ROOF SLOPES FROM TWO UNITS VERTICAL IN 12 UNITS HORIZONTAL (17-PERCENT SLOPE), UP TO FOUR UNITS VERTICAL IN 12 UNITS HORIZONTAL (33-PERCENT SLOPE), UNDERLAYMENT SHALL BE TWO LAYERS APPLIED IN THE FOLLOWING MANNER:
 - APPLY A 19 INCH STRIP OF UNDERLAYMENT FELT PARALLEL WITH AND STARTING AT THE EAVES, FASTENED SUFFICIENTLY TO HOLD IN PLACE. STARTING AT THE EAVES, APPLY 36 INCH WIDE SHEETS OF UNDERLAYMENT OVERLAPPING SUCCESSIVE SHEETS 19 INCHES, AND FASTENED SUFFICIENTLY TO HOLD IN PLACE.
 - FOR ROOF SLOPES OF FOUR UNITS VERTICAL IN 12 UNITS HORIZONTAL (33-PERCENT SLOPE) OR GREATER, UNDERLAYMENT SHALL BE ONE LAYER APPLIED IN THE FOLLOWING MANNER:
 - UNDERLAYMENT SHALL BE APPLIED SHINGLE FASHION, PARALLEL TO AND STARTING FROM THE EAVE AND LAPPED 2 INCHES, FASTENED SUFFICIENTLY TO HOLD IN PLACE. END LAPS SHALL BE OFFSET BY 6 FEET.

SHINGLE APPLICATION & FASTENING NOTES

- ASPHALT STRIP SHINGLES SHALL HAVE A MINIMUM OF SIX FASTENERS PER SHINGLE WHERE THE ROOF IS IN ONE OF THE FOLLOWING CATEGORIES:
 - THE BASIC WIND SPEED IS 110 MPH OR GREATER AND THE EAVE IS 20 FEET OR HIGHER ABOVE GRADE.
 - THE BASIC WIND SPEED IS 120 MPH OR GREATER.
 - SPECIAL WIND ZONES.

METAL ROOF APPLICATION & FASTENING NOTES

- INSTALL METAL ROOF PER MANUFACTURERS RECOMMENDATIONS FOR 150MPH WIND SPEED.

GENERAL UPLIFT CONNECTION NOTES

ROOF ASSEMBLY TO WALL ASSEMBLY: UPLIFT CONNECTIONS SHALL BE FROM RAFTER OR TRUSS TO WALL STUD. WHEN RAFTERS OR TRUSSES ARE NOT LOCATED DIRECTLY ABOVE STUDS, RAFTERS SHALL BE ATTACHED TO THE WALL PLATE AND THE WALL TOP PLATE SHALL BE ATTACHED TO THE WALL STUD WITH UPLIFT CONNECTIONS. UPLIFT CONNECTIONS SHALL BE IN ACCORDANCE WITH TABLE S103.10.

WALL ASSEMBLY TO WALL ASSEMBLY: STORY TO STORY UPLIFT CONNECTIONS FROM UPPER STORY WALL STUD TO LOWER STORY WALL STUD. WHEN UPPER STORY WALL STUDS ARE NOT LOCATED DIRECTLY ABOVE LOWER WALL STUDS, THE STUDS SHALL BE ATTACHED TO A COMMON MEMBER IN THE FLOOR ASSEMBLY BY UPLIFT CONNECTIONS. UPLIFT CONNECTIONS SHALL BE IN ACCORDANCE WITH TABLE S103.11.

WALL ASSEMBLY TO FOUNDATION: FIRST FLOOR WALL STUDS SHALL BE CONNECTED TO THE FOUNDATION, SILL, PLATE, OR BOTTOM PLATE. A MINIMUM OF A 1-1/4" x 20 GA. ASTM A663 GRADE 33 STEEL STRAP SHALL BE NAILED TO THE WALL STUDS AND HAVE A MINIMUM EMBEDMENT OF 1 INCHES IN CONCRETE FOUNDATIONS AND SLABS-ON-GRADE, 15 INCHES IN MASONRY BLOCK FOUNDATIONS, OR BE LAPPED UNDER THE BOTTOM PLATE. 3 INCH SQUARE WASHERS SHALL BE USED ON THE ANCHOR BOLTS AND ANCHOR BOLT SPACINGS SHALL NOT EXCEED THE REQUIREMENTS. STEEL STRAPS EMBEDDED IN OR IN CONTACT WITH SLAB-ON-GRADE OR MASONRY BLOCK FOUNDATIONS SHALL BE HOT-DIPPED GALV. AFTER FABRICATION, OR MANUF. FROM G185 OR Z450 GALV. STL. CONNECTIONS SHALL BE IN ACCORDANCE WITH TABLE S103.12.

TABLE S103.1 - ROOF SHEATHING ATTACHMENT REQUIREMENT - WIND LOAD EXP "C"

SHEATHING LOCATION	RAFTER / TRUSS SPACING	E F	
		MAX NAIL SPACING FOR 8d COMMON NAILS OR 10d BOX NAILS (INCHES OC)	
INTERIOR ZONE	12" OC	6	12
	16" OC	6	12
	24" OC	6	12
PERIMETER EDGE ZONE	12" OC	6	6
	16" OC	4	4
	24" OC	3	3

150 MPH WIND - EXPOSURE 'C' TYPICAL
E = NAIL SPACING AT PANEL EDGES, INCHES.
F = NAIL SPACING AT INTERMEDIATE SUPPORTS IN THE PANEL FIELD, INCHES.

TABLE S103.1 - WALL SHEATHING AND CLADDING REQUIREMENT - WIND LOAD EXP "C"

SHEATHING LOCATION	RAFTER / TRUSS SPACING	E F	
		MAX NAIL SPACING FOR 8d COMMON NAILS OR 10d BOX NAILS (INCHES OC)	
INTERIOR ZONE	12" OC	6	12
	16" OC	6	12
	24" OC	6	6
PERIMETER EDGE ZONE	12" OC	6	12
	16" OC	6	12
	24" OC	6	6

150 MPH WIND - EXPOSURE 'C' TYPICAL
E = NAIL SPACING AT PANEL EDGES, INCHES.
F = NAIL SPACING AT INTERMEDIATE SUPPORTS IN THE PANEL FIELD, INCHES.

DAMMON ENGINEERING, INC.
LOUISIANA & MISSISSIPPI
www.dammonengineering.com
info@dammonengineering.com
554 Old Spanish Trail
Slidell, LA 70458
PH: 985.649.5832 F: 985.641.5950

REVISIONS

#	DESCRIPTION	DATE
1	Revised drawing to meet IBC 2021 requirements 02/20/23	

SEAL:

NEW HOTEL FOR A Z N I A T N G T S A J S

150 BEACH BOULEVARD, U.S. HWY. 90
BLOOMINGVILLE, MISSISSIPPI 39500
JOB No: 2351 DATE: 10-11-2016
DRAWN BY: JTL CHECKED BY: JTL

SHEET TITLE: TYPICAL CONNECTION DETAILS, SCHEDULES, AND NOTES
DRAWING NUMBER: **S103**
SHEET No: 9 of 53