

#### 4.6 PARKING AND PASSENGER LOADING ZONES.

4.6.1 MINIMUM WIDTH. PARKING SPACES REQUIRED TO BE ACCESSIBLE BY 4.1 SHALL COMPLY WITH 4.6.2 THROUGH 4.6.4. PASSENGER LOADING ZONES REQUIRED TO BE ACCESSIBLE BY 4.1

4.6.2 LOCATION. ACCESSIBLE PARKING SPACES SERVING A PARTICULAR BUILDING SHALL BE LOCATED ON THE SHORTEST ACCESSIBLE ROUTE OF TRAVEL FROM ADJACENT PARKING TO AN ACCESSIBLE PASSENGER ENTRANCE OF THE BUILDING. ACCESSIBLE ENTRANCES TRAVEL TO AN ACCESSIBLE PASSENGER ENTRANCE OF THE BUILDING. ACCESSIBLE ENTRANCES TO THE ACCESSIBLE PASSENGER LOADING ZONES SHALL BE DISPERSED AND LOCATED CLOSEST TO THE ACCESSIBLE ENTRANCES.

4.6.3 PARKING SPACES. PARKING SPACES FOR DISABLED PEOPLE SHALL BE AT LEAST 9'6" (2900 mm) WIDE AND SHALL HAVE AN ADJACENT ACCESSIBLE PARKING SPACE WITH A MINIMUM CLEARANCE OF 8'0" (2440 mm) FROM THE CURB. TWO ACCESSIBLE PARKING SPACES MAY CLUMP TOGETHER TO PROVIDE ONE accessible parking space. PARKING SPACES AND ACCESSIBLE SPACES SHALL BE LEVEL WITH SURFACE SLOPES NOT EXCEEDING 1:50 IN ALL DIRECTIONS.

EXCEPTION: IF ACCESSIBLE PARKING SPACES FOR HANDICAPPED PERSONS ARE PROVIDED, EACH SHOULD HAVE AN ADJACENT ACCESSIBLE SPACE AT LEAST 9'6" (2900 mm) WIDE AND SHALL COMPLY WITH 4.6.3 AND 4.6.4.

4.6.4 SIGNAGE. ACCESSIBLE PARKING SPACES SHALL BE DESIGNATED AS RESERVED FOR THE USE OF INDIVIDUALS WITH PHYSICAL, MENTAL, OR SENSORY DISABILITIES. SUCH SPACES SHALL NOT BE OCCUPIED BY A VEHICLE PARKED IN THE SPACE (4.2.9). SUCH SPACES SHALL NOT BE DESIGNATED AS RESERVED FOR THE USE OF INDIVIDUALS WITH PHYSICAL, MENTAL, OR SENSORY DISABILITIES.

4.6.5 PASSENGER LOADING ZONES. PASSENGER LOADING ZONES SHALL BE PROVIDED FOR THE USE OF INDIVIDUALS WITH PHYSICAL, MENTAL, OR SENSORY DISABILITIES. SUCH SPACES SHALL BE AT LEAST 6'0" (1830 mm) WIDE AND 20' (6100 mm) LONG AND SHALL BE LEVEL WITH SURFACE SLOPES NOT EXCEEDING 1:50 IN ALL DIRECTIONS.

4.6.6 VERTICAL CLEARANCE. PASSENGER LOADING ZONES SHALL PROVIDE AN ACCESSIBLE AT LEAST 8'0" (2440 mm) CLEARANCE FROM THE CURB TO THE TOP OF THE OVERHANGING STRUCTURE. THE CLEARANCE SHALL BE MEASURED FROM THE TOP OF THE CURB TO THE BOTTOM OF THE OVERHANGING STRUCTURE. THE CLEARANCE SHALL BE MEASURED FROM THE TOP OF THE CURB TO THE BOTTOM OF THE OVERHANGING STRUCTURE. THE CLEARANCE SHALL BE MEASURED FROM THE TOP OF THE CURB TO THE BOTTOM OF THE OVERHANGING STRUCTURE.

#### 4.7 CURB RAMPS.

4.7.1 LOCATION. CURB RAMPS COMPLY WITH 4.7 SHALL BE PROVIDED WHEREVER AN ACCESSIBLE ROUTE OF TRAVEL IS REQUIRED.

4.7.2 SLOPE. SLOPES OF CURB RAMPS SHALL COMPLY WITH 4.7.2. THE SLOPE OF CURB RAMPS SHALL BE AT LEAST 1:10. THE SLOPE OF CURB RAMPS SHALL BE AT LEAST 1:10. THE SLOPE OF CURB RAMPS SHALL BE AT LEAST 1:10. THE SLOPE OF CURB RAMPS SHALL BE AT LEAST 1:10.

4.7.3 WIDTH. THE MINIMUM WIDTH OF A CURB RAMP SHALL BE 36" EXCLUSIVE OF PARDED SPACES.

4.7.4 SURFACE. SURFACES OF CURB RAMPS SHALL COMPLY WITH 4.5.

4.7.5 CROSSING. SURFACES OF CURB RAMPS SHALL COMPLY WITH 4.5.

4.7.6 BUILT-UP CURB RAMPS. BUILT-UP CURB RAMPS SHALL BE LOCATED SO THAT THEY DO NOT PROJECT INTO VEHICULAR TRAFFIC LANE (SEE FIG. 13).

4.7.7 WARNING TEXTURES. (REMOVED AND RESERVED).

4.7.8 OBSTRUCTIONS. CURB RAMPS SHALL BE LOCATED OR PROTECTED TO PREVENT THEIR OBSTRUCTION BY PARKED VEHICLES.

4.7.9 LOCATION AT MARKED CROSSINGS. CURB RAMPS AT MARKED CROSSINGS SHALL BE WHOLLY WITHIN THE MARKED CROSSING.

#### 4.8 RAMPS.

4.8.1 GENERAL. PART OF AN ACCESSIBLE ROUTE WITH A SLOPE GREATER THAN 1:20 SHALL BE CONSIDERED A RAMP AND SHALL COMPLY WITH 4.8.

4.8.2 SLOPE & RISE. THE LEAST POSSIBLE SLOPE SHALL BE USED FOR ANY RAMP. THE SLOPE OF ANY RAMP SHALL BE AT LEAST 1:12. THE SLOPE OF ANY RAMP SHALL BE AT LEAST 1:12. THE SLOPE OF ANY RAMP SHALL BE AT LEAST 1:12.

4.8.3 CLEAR WIDTHS. THE MINIMUM CLEAR WIDTH OF A RAMP SHALL BE 36" (915mm).

4.8.4 LANDINGS. RAMPS SHALL HAVE LEVEL LANDINGS AT THE BOTTOM AND TOP OF EACH RAMP. THE MINIMUM CLEAR WIDTH OF A RAMP SHALL BE 36" (915mm).

4.8.5 HANDRAILS. IF A RAMP RUN HAS A RISE GREATER THAN 1:20 (50mm) OR A RISE GREATER THAN 1:12 (83mm), HANDRAILS SHALL BE PROVIDED ON BOTH SIDES OF THE RAMP. HANDRAILS SHALL BE PROVIDED ON BOTH SIDES OF THE RAMP. HANDRAILS SHALL BE PROVIDED ON BOTH SIDES OF THE RAMP.

4.8.6 GROSS SLOPE & SURFACES. THE GROSS SLOPE OF RAMP SURFACES SHALL BE NO GREATER THAN 1:50. RAMP SURFACES SHALL COMPLY WITH 4.5.

4.8.7 PROTECTION. RAMPS AND LANDINGS WITH GRIP-OFFS SHALL HAVE CURBS, WALLS, BARRIERS, OR PROTECTIVE SURFACES THAT PREVENT SPILLS FROM SLIPPING OFF THE RAMP. RAMPS AND LANDINGS WITH GRIP-OFFS SHALL HAVE CURBS, WALLS, BARRIERS, OR PROTECTIVE SURFACES THAT PREVENT SPILLS FROM SLIPPING OFF THE RAMP.

4.8.8 OUTDOOR CONDITIONS. OUTDOOR RAMPS AND THEIR APPROACHES SHALL BE DESIGNED SO THAT WATER WILL NOT ACCUMULATE ON WALKING SURFACES.

#### 4.9 STAIRS.

4.9.1 MINIMUM NUMBER. STAIRS REQUIRED TO BE ACCESSIBLE BY 4.1 SHALL COMPLY WITH 4.9.

4.9.2 TREADS & RISERS. STAIRS SHALL BE ON AN ACCESSIBLE ROUTE AND SHALL COMPLY WITH 4.9.2 THROUGH 4.9.4. STAIRS SHALL BE ON AN ACCESSIBLE ROUTE AND SHALL COMPLY WITH 4.9.2 THROUGH 4.9.4. STAIRS SHALL BE ON AN ACCESSIBLE ROUTE AND SHALL COMPLY WITH 4.9.2 THROUGH 4.9.4.

4.9.3 HANDRAILS. THE HANDRAILS OF STAIRS SHALL NOT BE SHARPER THAN THE POINTS OF CONTACT. THE HANDRAILS OF STAIRS SHALL NOT BE SHARPER THAN THE POINTS OF CONTACT. THE HANDRAILS OF STAIRS SHALL NOT BE SHARPER THAN THE POINTS OF CONTACT.

4.9.4 HANDRAILS. STAIRS SHALL HAVE HANDRAILS AT BOTH SIDES OF ALL STAIRS. STAIRS SHALL HAVE HANDRAILS AT BOTH SIDES OF ALL STAIRS. STAIRS SHALL HAVE HANDRAILS AT BOTH SIDES OF ALL STAIRS.

4.9.5 HANDRAILS. STAIRS SHALL HAVE HANDRAILS AT BOTH SIDES OF ALL STAIRS. STAIRS SHALL HAVE HANDRAILS AT BOTH SIDES OF ALL STAIRS. STAIRS SHALL HAVE HANDRAILS AT BOTH SIDES OF ALL STAIRS.

4.9.6 HANDRAILS. STAIRS SHALL HAVE HANDRAILS AT BOTH SIDES OF ALL STAIRS. STAIRS SHALL HAVE HANDRAILS AT BOTH SIDES OF ALL STAIRS. STAIRS SHALL HAVE HANDRAILS AT BOTH SIDES OF ALL STAIRS.

4.9.7 HANDRAILS. STAIRS SHALL HAVE HANDRAILS AT BOTH SIDES OF ALL STAIRS. STAIRS SHALL HAVE HANDRAILS AT BOTH SIDES OF ALL STAIRS. STAIRS SHALL HAVE HANDRAILS AT BOTH SIDES OF ALL STAIRS.

4.9.8 HANDRAILS. STAIRS SHALL HAVE HANDRAILS AT BOTH SIDES OF ALL STAIRS. STAIRS SHALL HAVE HANDRAILS AT BOTH SIDES OF ALL STAIRS. STAIRS SHALL HAVE HANDRAILS AT BOTH SIDES OF ALL STAIRS.

4.9.9 HANDRAILS. STAIRS SHALL HAVE HANDRAILS AT BOTH SIDES OF ALL STAIRS. STAIRS SHALL HAVE HANDRAILS AT BOTH SIDES OF ALL STAIRS. STAIRS SHALL HAVE HANDRAILS AT BOTH SIDES OF ALL STAIRS.

4.9.10 HANDRAILS. STAIRS SHALL HAVE HANDRAILS AT BOTH SIDES OF ALL STAIRS. STAIRS SHALL HAVE HANDRAILS AT BOTH SIDES OF ALL STAIRS. STAIRS SHALL HAVE HANDRAILS AT BOTH SIDES OF ALL STAIRS.

4.9.11 HANDRAILS. STAIRS SHALL HAVE HANDRAILS AT BOTH SIDES OF ALL STAIRS. STAIRS SHALL HAVE HANDRAILS AT BOTH SIDES OF ALL STAIRS. STAIRS SHALL HAVE HANDRAILS AT BOTH SIDES OF ALL STAIRS.

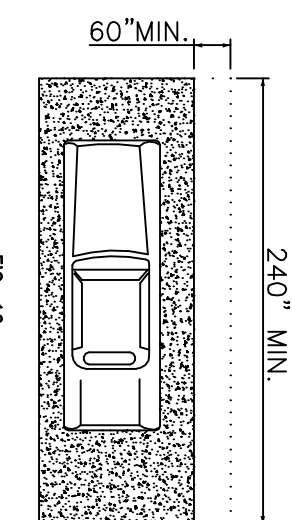

#### ACCESS AISLE AT PASSENGER LOADING ZONES

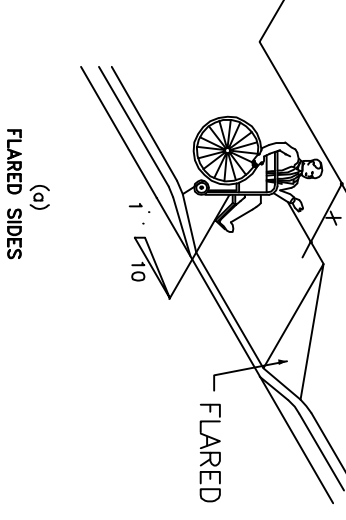
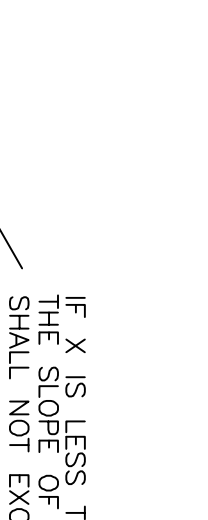

#### SIDES OF CURB RAMPS

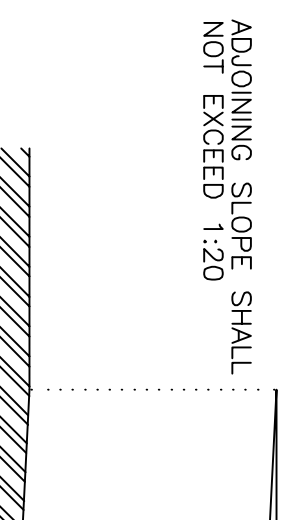
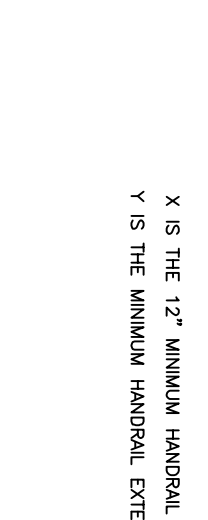
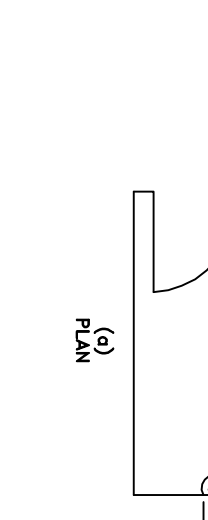
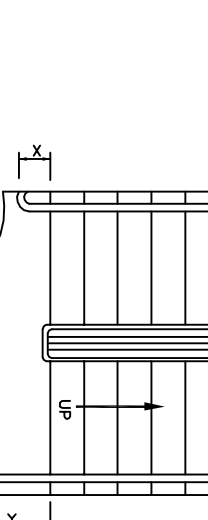
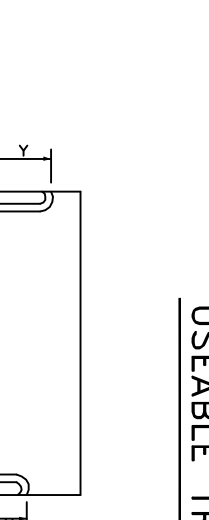
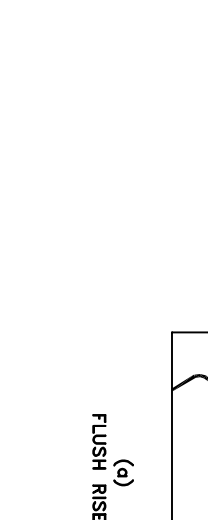
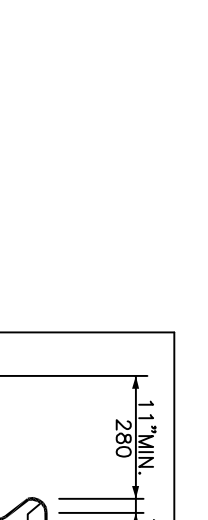
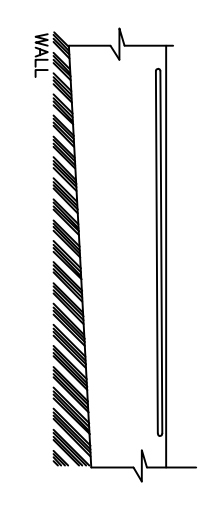
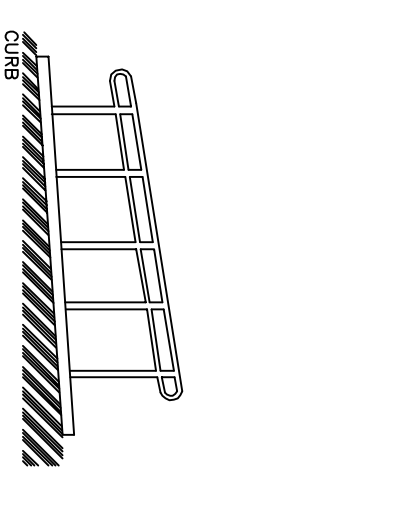

#### USEABLE TREAD WIDTH AND EXAMPLES OF ACCEPTABLE NOSINGS

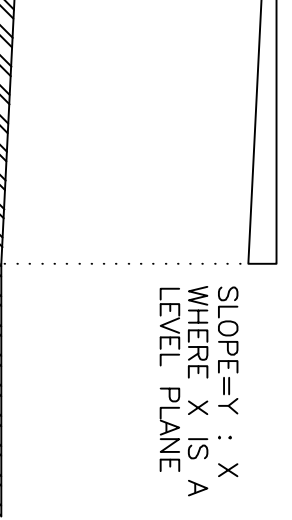
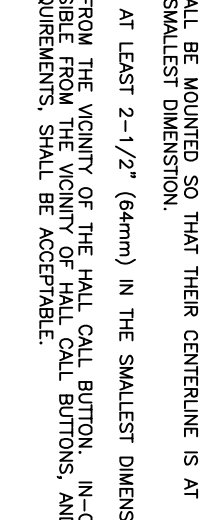
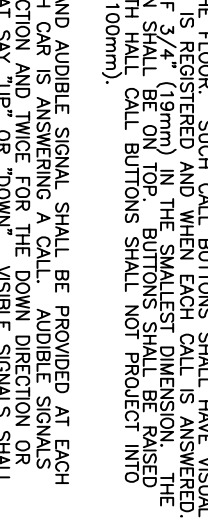
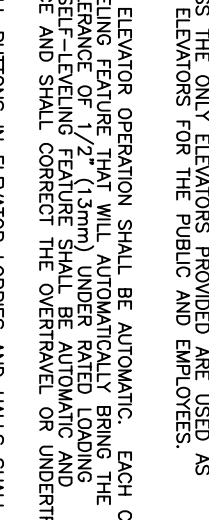
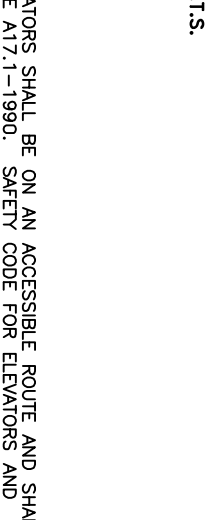
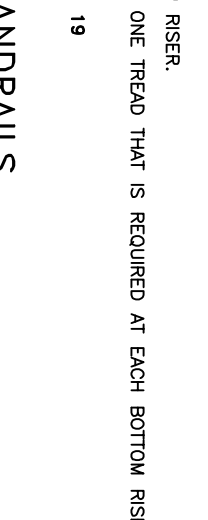
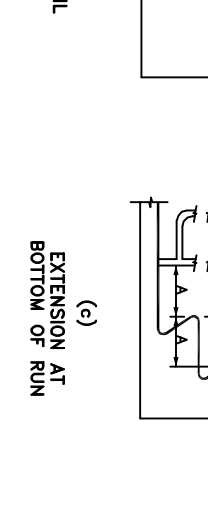
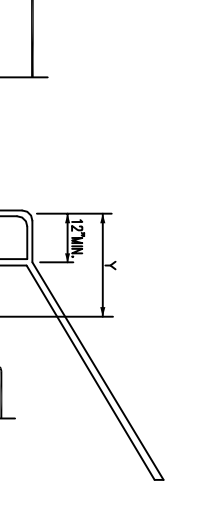
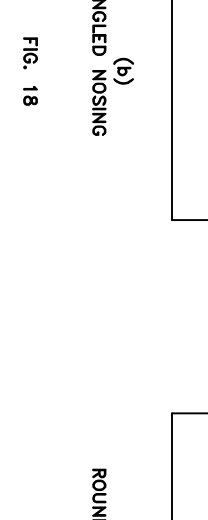
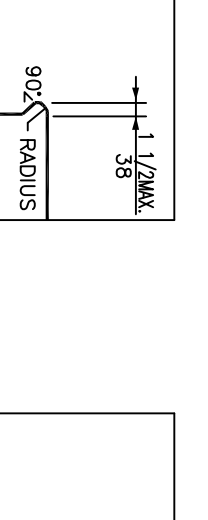
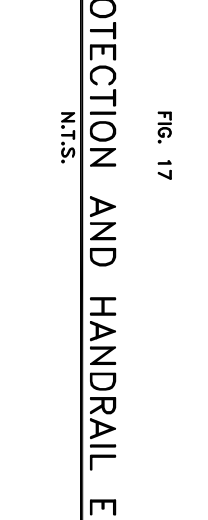
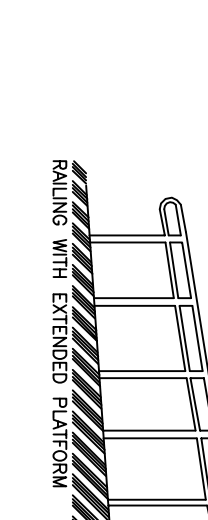
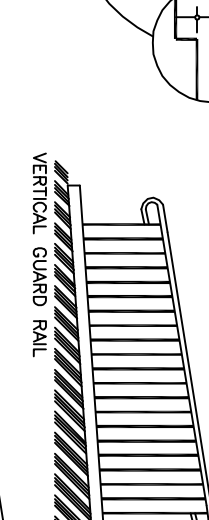

#### MEASUREMENT OF CURB RAMP SLOPES

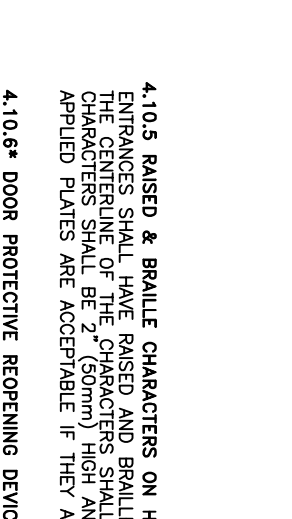
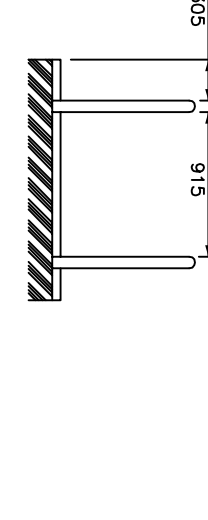
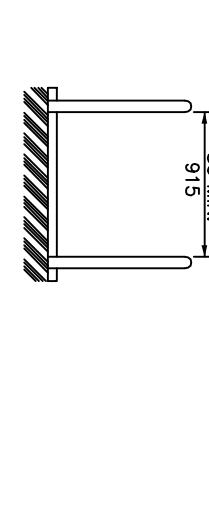
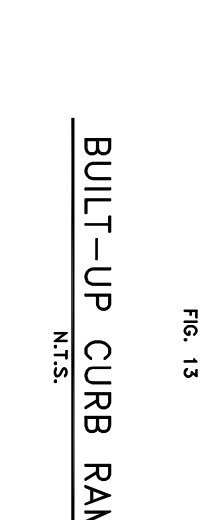
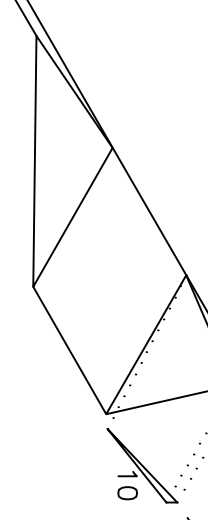

#### BUILT-UP CURB RAMP

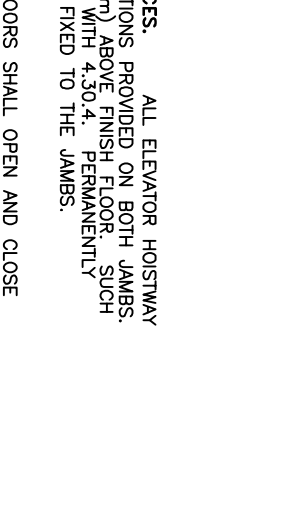
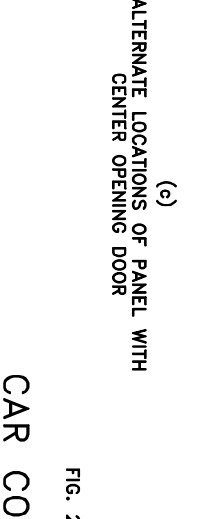
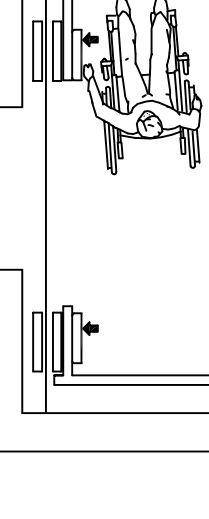
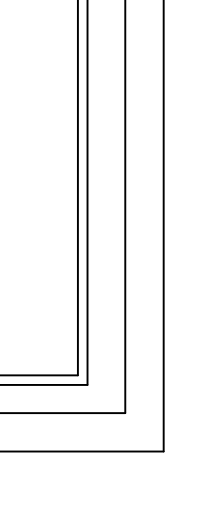
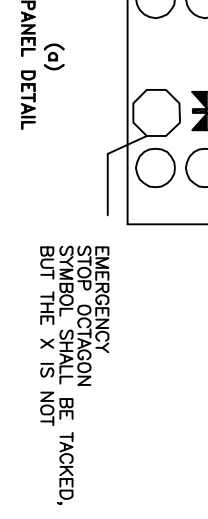
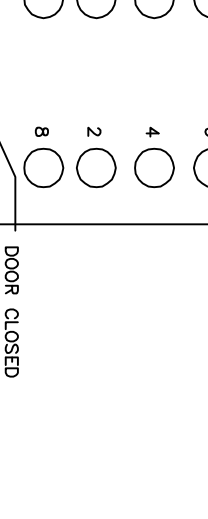
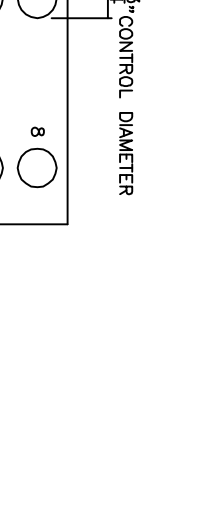
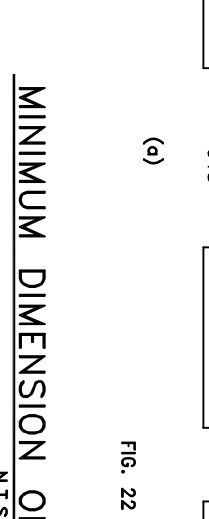
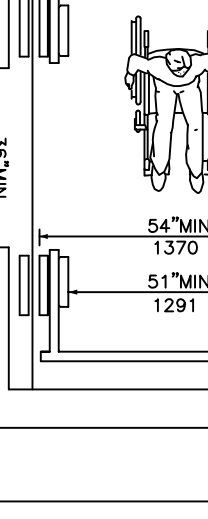
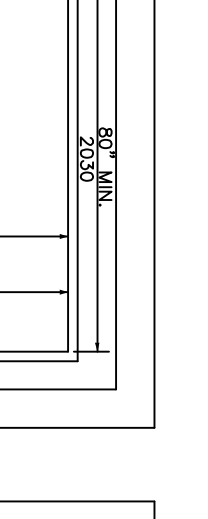
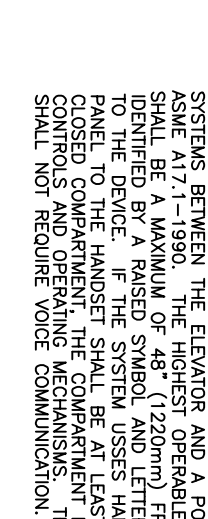
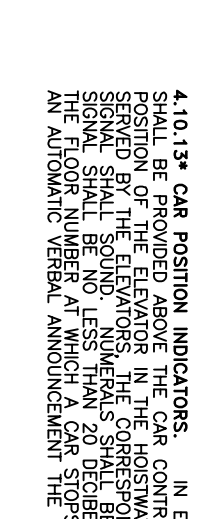
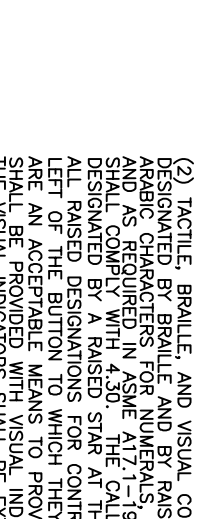
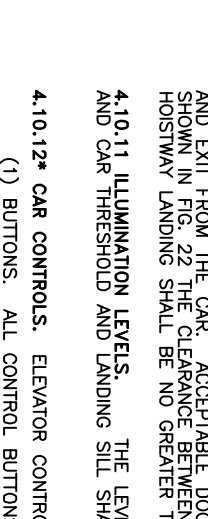
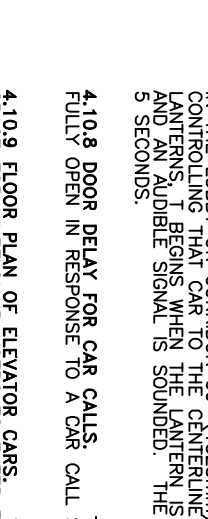
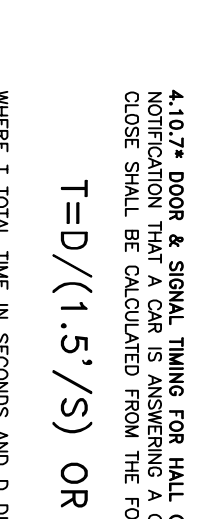

#### EXAMPLES OF EDGE PROTECTION AND HANDRAIL EXTENSIONS

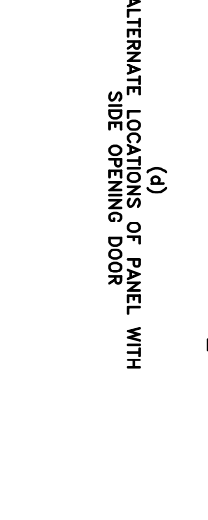
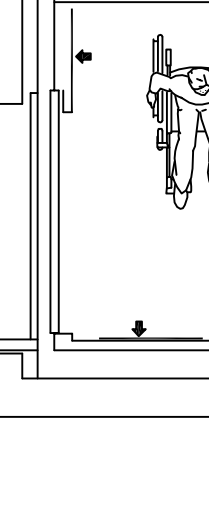
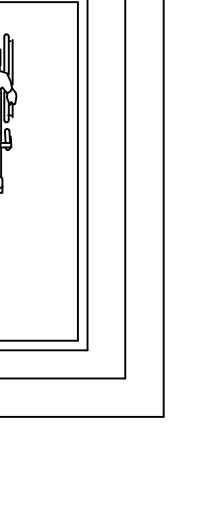
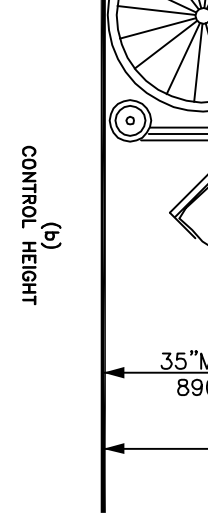
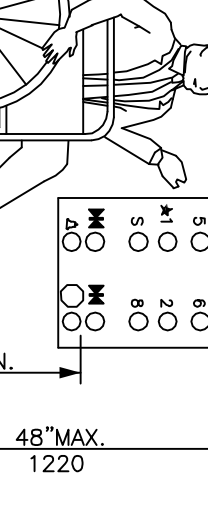
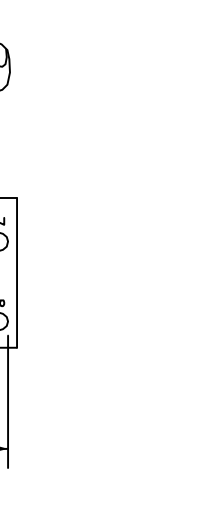
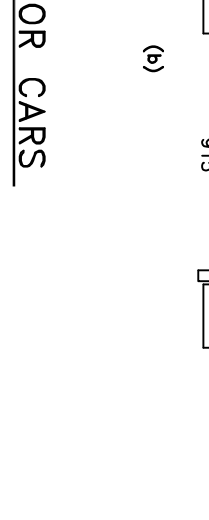
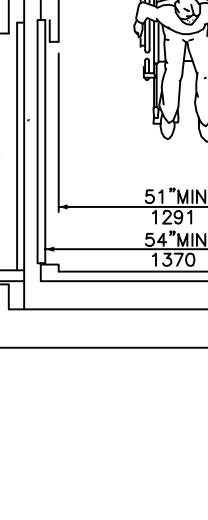
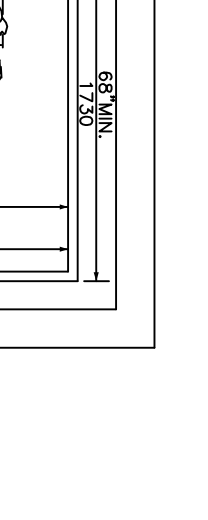
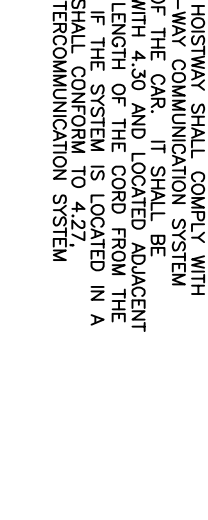
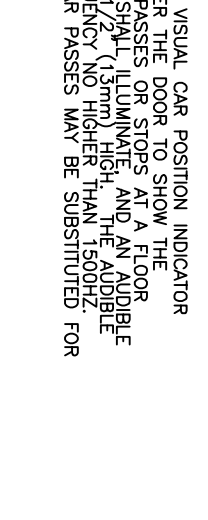
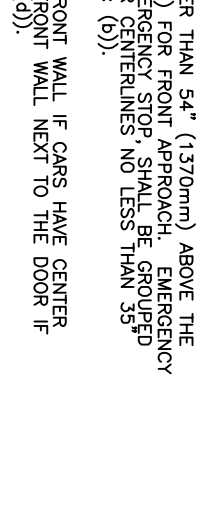
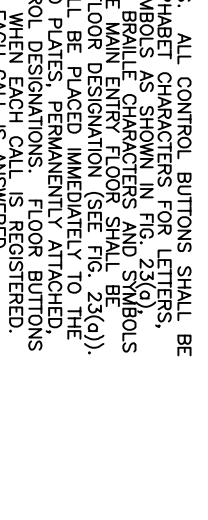
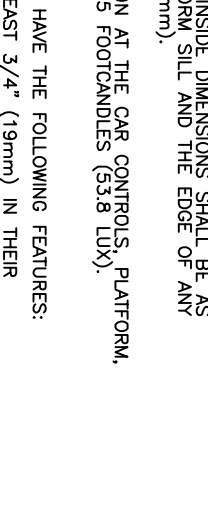
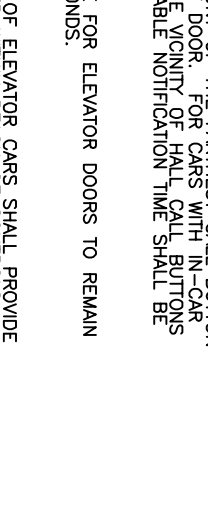
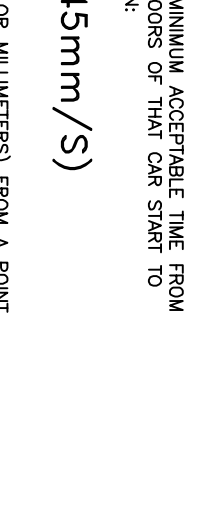

#### MINIMUM DIMENSION OF ELEVATOR CARS

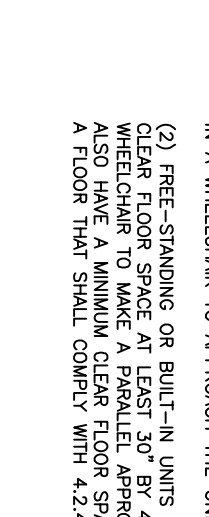
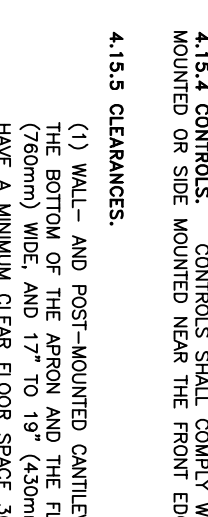
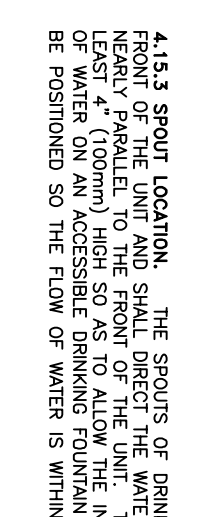
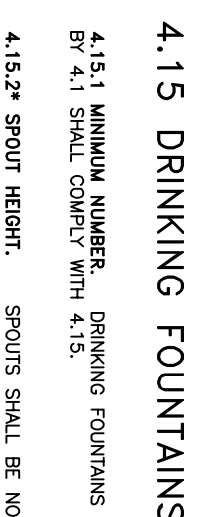
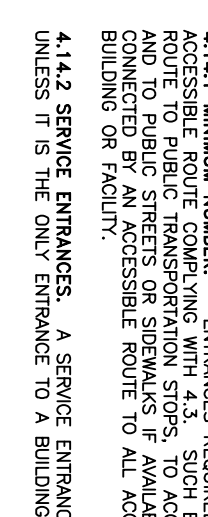
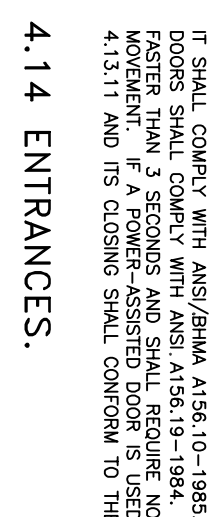
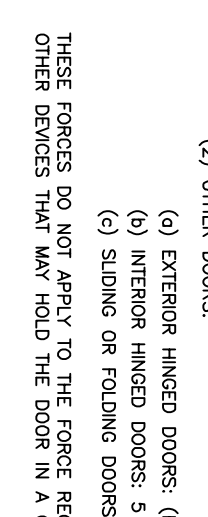
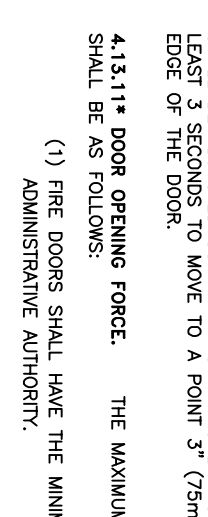
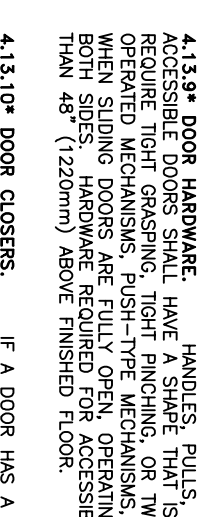
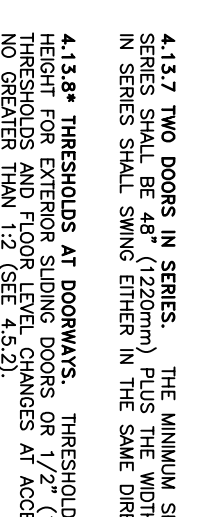
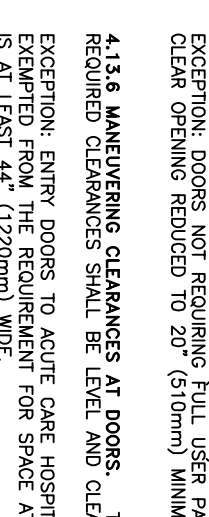
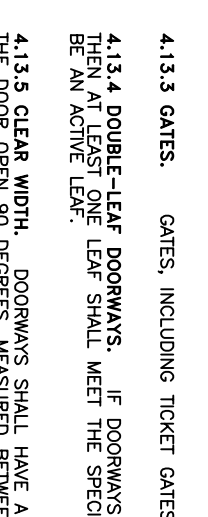
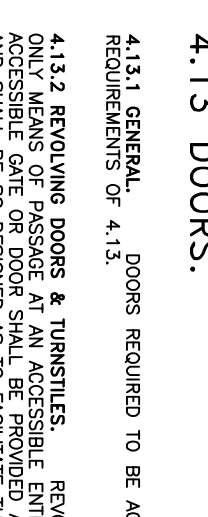
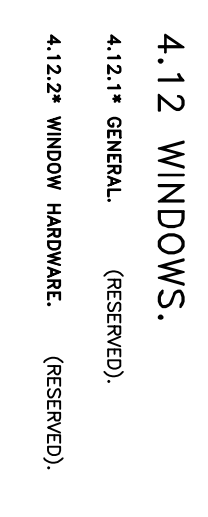
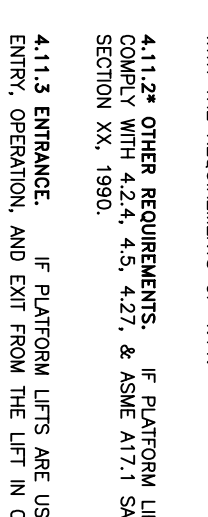

#### CAR CONTROLS

