

**REFRIGERATOR MANUFACTURER**  
**Turbo air**  
 more durable, efficient, beautiful

4184 E. Conant St.  
 Long Beach, CA 90808  
 Tel. 310-900-1000  
 Fax. 310-900-1077  
[www.turboairinc.com](http://www.turboairinc.com)

Project :	
Model # :	
Item # :	Qty :
Available W/H :	
Approval :	

## Undercounter Freezer

Undercounters  
 M3 Series

### Patented Self-Cleaning Condenser



This product is equipped with a fine mesh filter to the front of the condenser to catch dust, and a rotating brush that moves up and down daily to remove excess buildup outward and away.

**Model : MUF-36-N**



### ≡ FEATURES & BENEFITS ≡

- Self-Cleaning Condenser**  
 The accumulation of dust in the condenser can cause the failure or breakdown of refrigerators. Refrigerators run normally until they reach a certain level of accumulation. At some point, when they are over the limit, their performance drops quickly resulting in damage to, or disposal of the stored products inside. The Self-Cleaning Condenser device keeps the condenser clean and prevents system failure by automatically brushing daily.
- Digital temperature control & monitor system**  
 Keep food products safe by maintaining constant temperatures. External digital display allows for easy monitoring.
- Hydrocarbon refrigerants (R-290)**  
 With innovative and eco-friendly technology, Turbo Air brings you hydrocarbon refrigerators designed to meet the new standards of the EPA and DOE in 2017. Hydrocarbon refrigerants do not deplete the ozone layer and have very low contribution to global warming (ODP-0, GWP-3).
- Stainless steel cabinet construction**  
 The Turbo Air M3 model boasts a stainless steel exterior (galvanized steel back and bottom). Interior is stainless steel floor with AL sides and back. It guarantees the utmost in cleanliness and long product life. The M3 model adds a touch of style to the most refined setting.
- High-density polyurethane insulation**  
 The entire cabinet structure and solid doors are foamed-in-place using high density, CFC free polyurethane insulation.
- Ergonomically designed doors**  
 Customers' fatigue fades away with easy grip handles and doors that open effortlessly. These features along with self-closing doors make this the ultimate choice in customer convenience. ABS sheet door liners resist water condensation with thermal efficiency.
- Magnetic door gaskets**  
 Magnetic door gaskets are of one-piece construction, removable without tools for ease of cleaning and replacement.
- LED interior lighting**
- Adjustable, heavy duty, PE (polyethylene) coated wire shelves**
- Freezer holds -10°F ~ 0°F for the best in frozen food preservation**

**NATURAL Refrigerant**



Model	Swing Door	CU./FT.	#of Shelves	HP	AMPS	Crated Weight (lbs.)	L x D x H <sup>†</sup> (inches)
MUF-36-N	2	9	2	2/5	2.7A	187	36 1/4 x 30 x 30 5/8

## Model : MUF-36-N

ELECTRICAL DATA	
Voltage	115/60/1
Plug Type	① NEMA 5-15P
Full Load Amperes	2.7A
Compressor HP	2/5
Cord Length (ft.)	9
Refrigerant	R-290
DIMENSIONAL DATA	
Net Capacity (cu. ft.)	9
Ext. Length Overall (in.)	36 1/4 (921mm)
Ext. Depth Overall (in.)*	30 (762mm)
Ext. Height Overall (in.)†	30 5/8 (777mm)
# of Doors	2
# of Shelves	2
Net Weight (lbs.)	160
Gross Weight (lbs.)	187
Shelf Size (in.)	15 x 17

Design and specifications subject to change without notice.

Actual shipping weight may differ due to extra packing materials for product protection.

\* Depth does not include 1" for rear spacers.

† Height does not include 5" for caster height.

■ **WARRANTY : 3 Year Parts and Labor Warranty  
Additional 2 Year Warranty on Compressor**

- **Anti-corrosion coated evaporator**
- **Self-contained system**
- **Standard 4" dia. swivel casters with locks on the front set**
- **2.5" caster available (optional)**
- **Legs available (optional)**
- **Back splash guard available (optional)**
- **Stainless steel double overshelf available (optional)**

■ **OPTIONAL ACCESSORIES :**

- 2.5" caster, 1/2" diameter & 13 TPI: 30265H0100 (non-brake), 30265H0200 (w/ brake)
- 5" caster, 1/2" diameter & 13 TPI: M726500100 (non-brake), M726500200 (w/ brake)
- 6" ABS plastic leg: 30221M0200
- 6" stainless steel leg: 30221M0600
- Additional PE coated wire shelf: WM37800100
- Back splash guard: TU-36B
- Stainless steel double overshelf: TSOS-3R
- Door lock: extra lead time will apply, please call factory for more details to order**

Ver.20170908

## PLAN VIEW

(unit : inch)

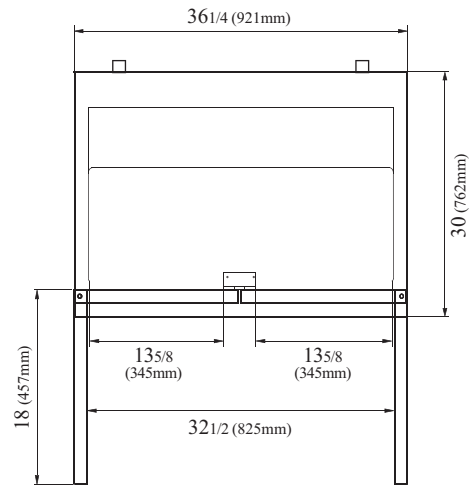

PLAN VIEW

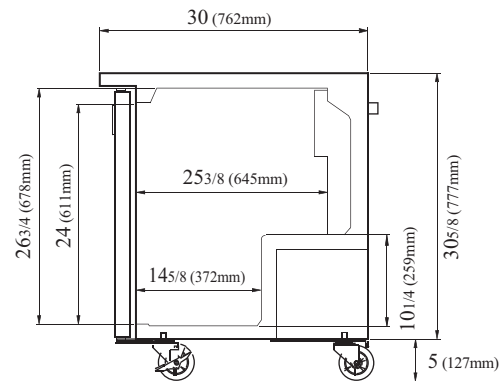

SIDE VIEW



- Turbo Air : 800-627-0032
- GK : 800-500-3519
- Warranty : 800-381-7770
- AC : 888-900-1002

