

Architectural Ceiling Diffusers Square Cone • Plaque Face

Model: OMNI • Steel • Round Neck

Border Type 3 (Lay-In) Full Face

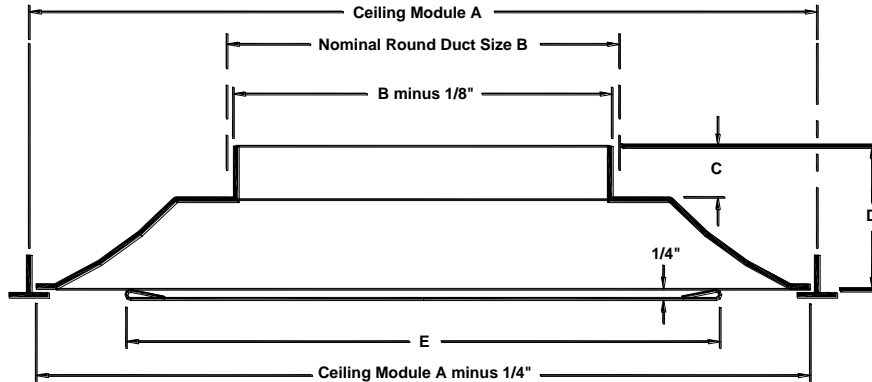

Ceiling Module	Face Size	Nominal Round Duct Sizes	Frame Types
12 x 12	12 x 12	4, 5*, 6, 7, 8	1, 2, 3, 4
20 x 20	20 x 20	4, 5*, 6, 8, 10	1, 3
24 x 24	24 x 24	6, 8, 10, 12, 14**, 15**	1, 2, 3, 4

All Dimensions Below In Millimeters

600 x 600	600 x 600	152, 203, 254, 305, 356**, 381**	3
-----------	-----------	----------------------------------	---

* Adapter is provided for sizes 4 and 5

** Aluminum back pan may be supplied for 14" [356mm] and 15" [381mm] inlet sizes

Ceiling Module A	Nominal Round Duct Sizes B	C	D	E
12 x 12	4, 5*	2 7/8	4	9
12 x 12	6, 7	1 1/8	2 1/4	9
12 x 12	8	1 1/4	2 3/8	9
20 x 20	4, 5*	2 3/4	5 1/4	13 5/8
20 x 20	6, 8, 10	3/4	3 1/4	13 5/8
24 x 24	6, 8	1 1/4	3 3/4	18
24 x 24	10, 12, 14**, 15**	1 3/8	3 7/8	18

All Dimensions Below In Millimeters

600 x 600	152, 203	32	95	457
600 x 600	254, 305, 356**, 381**	35	98	457

* Adapter is provided for sizes 4 and 5

** Aluminum back pan may be supplied for 14" [356mm] and 15" [381mm] inlet sizes

Border Type 1 (Surface Mount) Full Face
12 x 12 and 24 x 24 Module

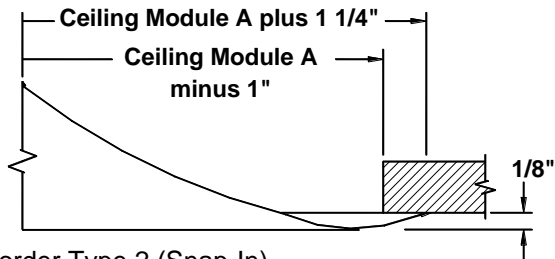

Border Type 2 (Snap-In)
Full Face or Panel Mounted

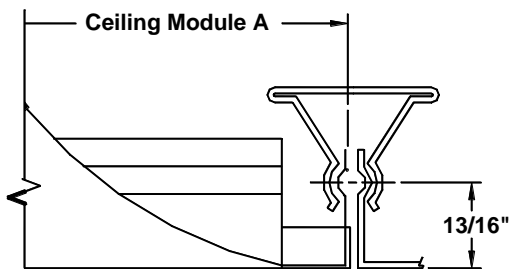

Border Type 1 (Surface Mount) Full Face
20 x 20 Module

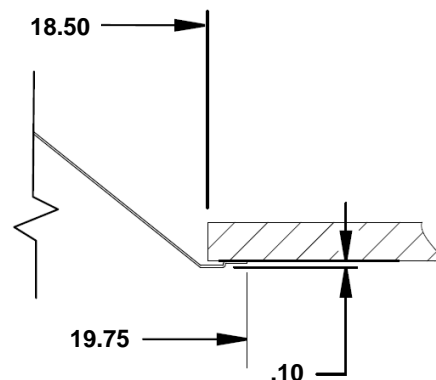

Dimensions are in inches.

Other Available Border Types Check if provided.

Border Type 4 (Spline) Full Face or Panel Mounted

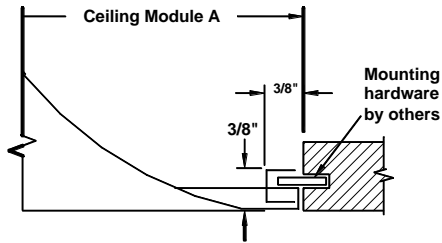

Border Type 4T (Clip-On Recessed Spline) Full Face

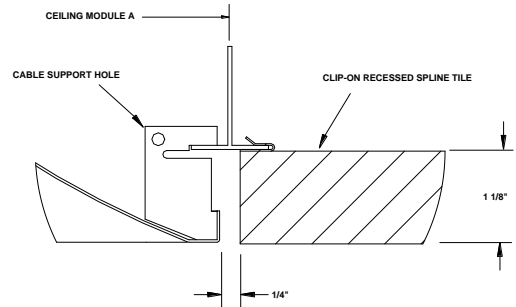

Border Type 4V (Recessed Spline) Full Face

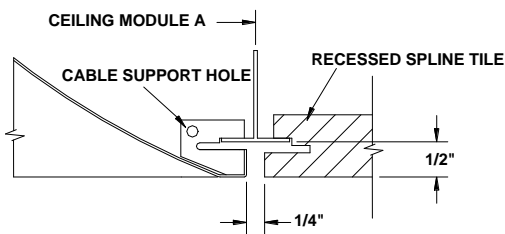

Note: If Border 4V is adjacent to a light fixture a gap will be visible above the backpan. A t-bar extender is available to fill this void, available from the ceiling manufacturer.

Borders 4V and 4T has four mounting clips. Two clips on opposed sides with holes to attach mounting wire from above.

Installing and Removing Face Panel • Adjusting Optional Damper

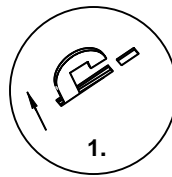
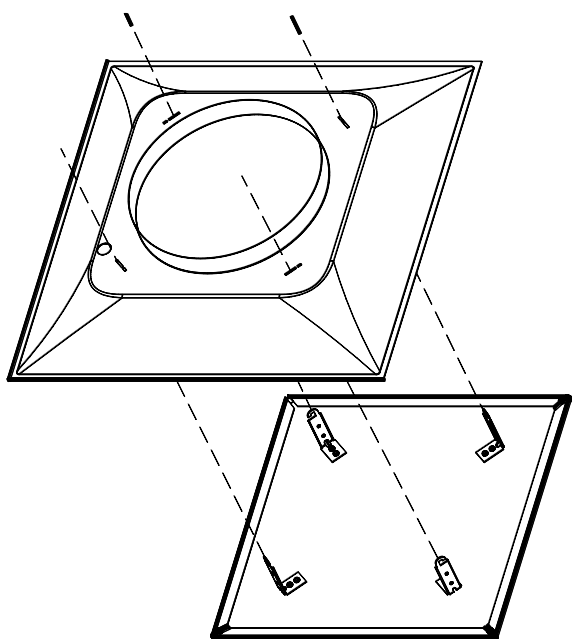

1.

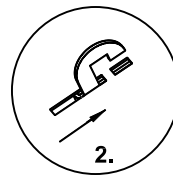

2.

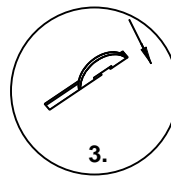

3.

Installing Face Panel

1. Insert the hook brackets into the slots in the backpan.
2. Rotate the face panel clockwise until...
3. The hooks positively engage in the secondary slots in the backpan.

Removing Face Panel

1. Lift the faceplate towards the backpan to disengage the hook brackets from the backpan slots.
2. Rotate the faceplate counter-clockwise.
3. Lower the faceplate away from the backpan.

Adjusting Optional Damper

1. Remove face panel as above.
2. Use flat blade screwdriver to turn operator shaft at center of damper.
3. Replace face panel

Accessories (Optional) Check if provided.

- Model D-75 Opposed Blade Damper
- Model EG Equalizing Grid

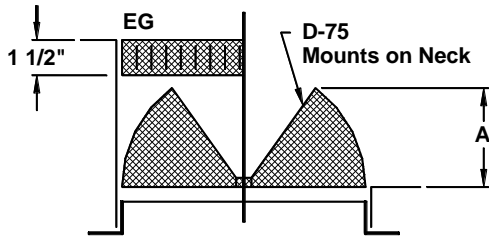

Model D-75 damper is available in duct sizes 6 thru 12 inches only.

- Model AG-75 Radial Opposed Blade Damper
- Model EG Equalizing Grid

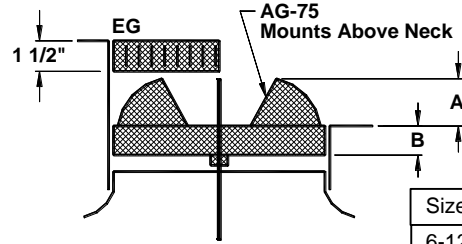

Size	B
6-12	1 1/2
14	2 1/8

Model AG-75 damper is available in 6, 7, 8, 10, 12, 14, and 15 inch duct sizes only.

- Model AG-85 Butterfly Damper
- Model EG Equalizing Grid

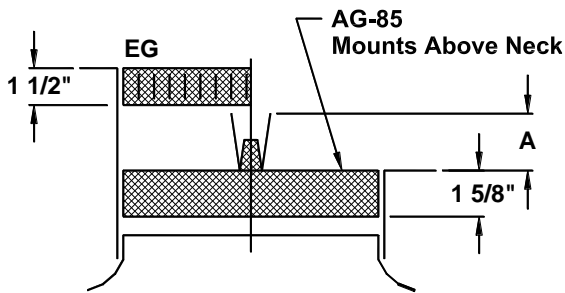

- Model AG-65 Combination Damper and Equalizing Grid

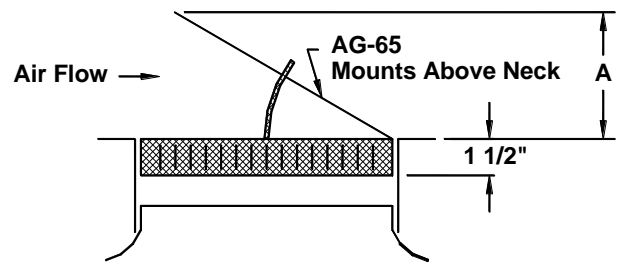

- Model D-100 Radial Sliding Blade Damper
- Model EG Equalizing Grid

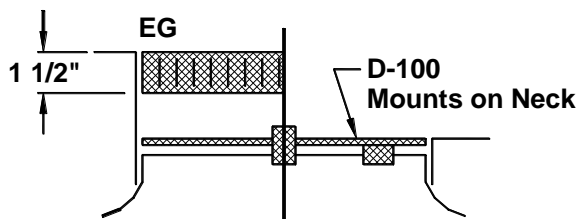

Model D-100 damper is available in duct sizes 6, 8, 10, 12 and 14 inch duct sizes only.

- Model AG-100 Radial Sliding Blade Damper
- Model EG Equalizing Grid

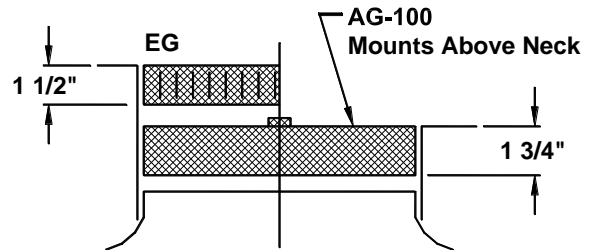

Model AG-100 damper is available in duct sizes 6, 8, 10, 12 and 14 inch duct sizes only.

- DB - Directional Blow Clips

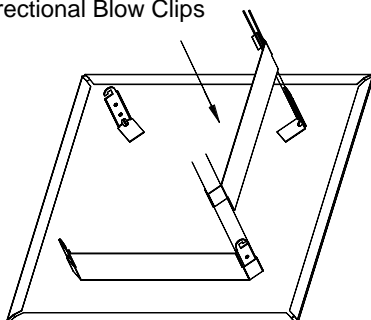

- TRM TITUS Rapid Mount Frame

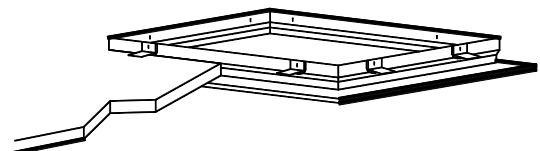

For Surface Mounting Border Type 3

Accessories (Optional) continued

Dimension "A" in Inches, for Dampers Shown

Accessories	Nominal Round Duct Sizes						
	6	7	8	10	12	14	15
D-75	2 3/8	2 7/8	3 1/4	4 1/8	4 7/8	N/A	N/A
AG-75	2 3/4	3 1/4	3 5/8	4 1/2	5 3/8	2 3/4	3
AG-85	2 1/2	3	3 1/2	4 1/2	5 1/2	6 1/2	7
AG-65	3 3/8	4	4 1/2	5 1/2	7 1/8	8 5/8	9
D-100	—	—	—	—	—	—	N/A
AG-100	—	—	—	—	—	—	N/A

Notes and : Model D-100 and AG-100 dampers have radial blades that slide in a horizontal plane. For that reason, no opening clearance "A" is dimensioned.

IB Molded Insulation Blanket

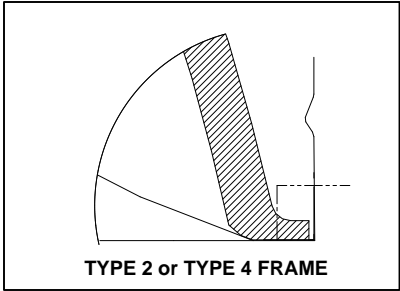
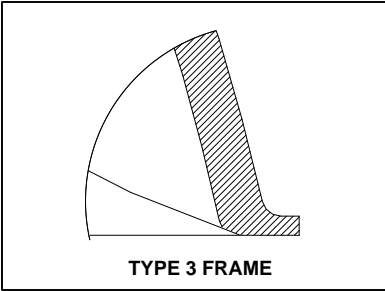
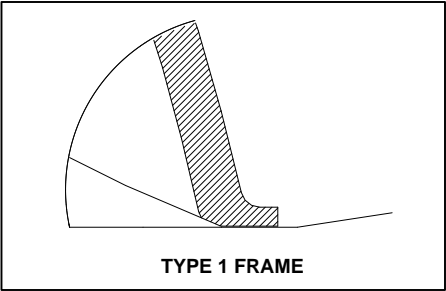
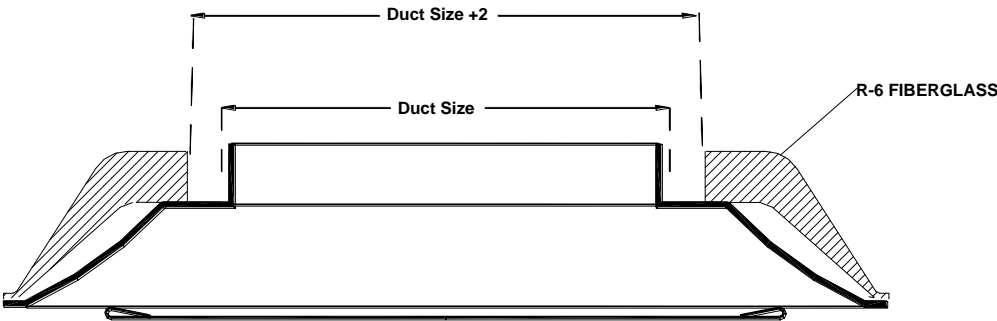

Standard Finish: #26 White

General Description

- The TITUS OMNI diffuser is designed to satisfy architectural as well as engineering criteria. Its strong, clean, unobtrusive lines harmonize with the ceiling system, without sacrificing performance.
- The curvature of the OMNI backpan works with the formed edges of the face panel to deliver a 3600 tight horizontal air pattern, without excessive noise or pressure drop.
- The OMNI diffuser is an excellent choice for variable volume systems. The air pattern remains tight and horizontal for effective room air distribution, even when the air volume varies over a wide range.
- The edges of the face panel are formed to a radius for solid, crisp appearance. The formed edges also stiffen the face panel and assure a straight and level surface.
- The panel can be removed from the backpan for easy installation of the diffuser or for access to the optional damper.
- Optional Directional Blow Clips (model DB) allow the air pattern to be changed to three, two or one blow direction.
- Optional molded insulation blanket (IB) with R-6 rating available for use with border styles 1, 2, 3, and 4, 24x24 full face models.

This submittal is meant to demonstrate general dimensions of this product. The drawings are not meant to detail every aspect of the product. Drawings are not to scale. Titus reserves the right to make changes without written notice.

All rights reserved. No part of this work may be reproduced or transmitted in any form or by any means, electronic or mechanical, including photocopying and recording, or by any information storage retrieval system without permission in writing from Air Distribution Technologies