

DIVISION **15**

MECHANICAL

DAMMON ENGINEERING, INC.
554 OLD Spanish Trail
SLIDELL, LOUISIANA 70458
Phone: 985-649-5832
Dammonengineering.com

SECTION 15053

COMMON WORK RESULTS FOR HVAC

PART 1 - GENERAL

1.1 RELATED DOCUMENTS

- A. Drawings and general provisions of the Contract, including General and Supplementary Conditions and Division 01 Specification Sections, apply to this Section.

1.2 SUMMARY

- A. This Section includes the following:
 - 1. Piping materials and installation instructions common to most piping systems.
 - 2. Transition fittings.
 - 3. Dielectric fittings.
 - 4. Mechanical sleeve seals.
 - 5. Sleeves.
 - 6. Escutcheons.
 - 7. Grout.
 - 8. HVAC demolition.
 - 9. Equipment installation requirements common to equipment sections.
 - 10. Painting and finishing.
 - 11. Concrete bases.
 - 12. Supports and anchorages.

1.3 DEFINITIONS

- A. Finished Spaces: Spaces other than mechanical and electrical equipment rooms, furred spaces, pipe and duct chases, unheated spaces immediately below roof, spaces above ceilings, unexcavated spaces, crawlspaces, and tunnels.
- B. Exposed, Interior Installations: Exposed to view indoors. Examples include finished occupied spaces and mechanical equipment rooms.
- C. Exposed, Exterior Installations: Exposed to view outdoors or subject to outdoor ambient temperatures and weather conditions. Examples include rooftop locations.
- D. Concealed, Interior Installations: Concealed from view and protected from physical contact by building occupants. Examples include above ceilings and chases.

- E. Concealed, Exterior Installations: Concealed from view and protected from weather conditions and physical contact by building occupants but subject to outdoor ambient temperatures. Examples include installations within unheated shelters.
- F. The following are industry abbreviations for plastic materials:
 - 1. CPVC: Chlorinated polyvinyl chloride plastic.
 - 2. PE: Polyethylene plastic.
 - 3. PVC: Polyvinyl chloride plastic.
- G. The following are industry abbreviations for rubber materials:
 - 1. EPDM: Ethylene-propylene-diene terpolymer rubber.
 - 2. NBR: Acrylonitrile-butadiene rubber.

1.4 SUBMITTALS

- A. Product Data: For the following:
 - 1. Transition fittings.
 - 2. Dielectric fittings.
 - 3. Mechanical sleeve seals.
 - 4. Escutcheons.
- B. Welding certificates.

1.5 QUALITY ASSURANCE

- A. Steel Support Welding: Qualify processes and operators according to AWS D1.1, "Structural Welding Code--Steel."
- B. Steel Pipe Welding: Qualify processes and operators according to ASME Boiler and Pressure Vessel Code: Section IX, "Welding and Brazing Qualifications."
 - 1. Comply with provisions in ASME B31 Series, "Code for Pressure Piping."
 - 2. Certify that each welder has passed AWS qualification tests for welding processes involved and that certification is current.
- C. Electrical Characteristics for HVAC Equipment: Equipment of higher electrical characteristics may be furnished provided such proposed equipment is approved in writing and connecting electrical services, circuit breakers, and conduit sizes are appropriately modified. If minimum energy ratings or efficiencies are specified, equipment shall comply with requirements.

1.6 DELIVERY, STORAGE, AND HANDLING

- A. Deliver pipes and tubes with factory-applied end caps. Maintain end caps through shipping, storage, and handling to prevent pipe end damage and to prevent entrance of dirt, debris, and moisture.
- B. Store plastic pipes protected from direct sunlight. Support to prevent sagging and bending.

1.7 COORDINATION

- A. Arrange for pipe spaces, chases, slots, and openings in building structure during progress of construction, to allow for HVAC installations.
- B. Coordinate installation of required supporting devices and set sleeves in poured-in-place concrete and other structural components as they are constructed.
- C. Coordinate requirements for access panels and doors for HVAC items requiring access that are concealed behind finished surfaces. Access panels and doors are specified in Division 08 Section "Access Doors and Frames."

PART 2 - PRODUCTS

2.1 MANUFACTURERS

- A. In other Part 2 articles where subparagraph titles below introduce lists, the following requirements apply for product selection:
 - 1. Available Manufacturers: Subject to compliance with requirements, manufacturers offering products that may be incorporated into the Work include, but are not limited to, the manufacturers specified.
 - 2. Manufacturers: Subject to compliance with requirements, provide products by the manufacturers specified.

2.2 PIPE, TUBE, AND FITTINGS

- A. Refer to individual Division 23 piping Sections for pipe, tube, and fitting materials and joining methods.
- B. Pipe Threads: ASME B1.20.1 for factory-threaded pipe and pipe fittings.

2.3 JOINING MATERIALS

- A. Refer to individual Division 23 piping Sections for special joining materials not listed below.
- B. Pipe-Flange Gasket Materials: Suitable for chemical and thermal conditions of piping system contents.
 - 1. ASME B16.21, nonmetallic, flat, asbestos-free, **1/8-inch** maximum thickness unless thickness or specific material is indicated.
 - a. Full-Face Type: For flat-face, Class 125, cast-iron and cast-bronze flanges.
 - b. Narrow-Face Type: For raised-face, Class 250, cast-iron and steel flanges.
 - 2. AWWA C110, rubber, flat face, **1/8 inch** thick, unless otherwise indicated; and full-face or ring type, unless otherwise indicated.
- C. Flange Bolts and Nuts: ASME B18.2.1, carbon steel, unless otherwise indicated.
- D. Plastic, Pipe-Flange Gasket, Bolts, and Nuts: Type and material recommended by piping system manufacturer, unless otherwise indicated.
- E. Solder Filler Metals: ASTM B 32, lead-free alloys. Include water-flushable flux according to ASTM B 813.
- F. Brazing Filler Metals: AWS A5.8, BCuP Series, copper-phosphorus alloys for general-duty brazing, unless otherwise indicated; and AWS A5.8, BAg1, silver alloy for refrigerant piping, unless otherwise indicated.
- G. Welding Filler Metals: Comply with AWS D10.12 for welding materials appropriate for wall thickness and chemical analysis of steel pipe being welded.
- H. Solvent Cements for Joining Plastic Piping:
 - 1. CPVC Piping: ASTM F 493.
 - 2. PVC Piping: ASTM D 2564. Include primer according to ASTM F 656.
- I. Fiberglass Pipe Adhesive: As furnished or recommended by pipe manufacturer.

2.4 TRANSITION FITTINGS

- A. Plastic-to-Metal Transition Fittings: CPVC and PVC one-piece fitting with manufacturer's Schedule 80 equivalent dimensions; one end with threaded brass insert, and one solvent-cement-joint end.
 - 1. Available Manufacturers:

- a. Eslon Thermoplastics.
- B. Plastic-to-Metal Transition Adaptors: One-piece fitting with manufacturer's SDR 11 equivalent dimensions; one end with threaded brass insert, and one solvent-cement-joint end.
 - 1. Available Manufacturers:
 - a. Thompson Plastics, Inc.
- C. Plastic-to-Metal Transition Unions: MSS SP-107, CPVC and PVC four-part union. Include brass end, solvent-cement-joint end, rubber O-ring, and union nut.
 - 1. Available Manufacturers:
 - a. NIBCO INC.
 - b. NIBCO, Inc.; Chemtrol Div.

2.5 DIELECTRIC FITTINGS

- A. Description: Combination fitting of copper alloy and ferrous materials with threaded, solder-joint, plain, or weld-neck end connections that match piping system materials.
- B. Insulating Material: Suitable for system fluid, pressure, and temperature.
- C. Dielectric Unions: Factory-fabricated, union assembly, for 250-psig minimum working pressure at 180 deg F.
 - 1. Available Manufacturers:
 - a. Capitol Manufacturing Co.
 - b. Central Plastics Company.
 - c. Eclipse, Inc.
 - d. Epco Sales, Inc.
 - e. Hart Industries, International, Inc.
 - f. Watts Industries, Inc.; Water Products Div.
 - g. Zurn Industries, Inc.; Wilkins Div.
- D. Dielectric Flanges: Factory-fabricated, companion-flange assembly, for 150- or 300-psig minimum working pressure as required to suit system pressures.
 - 1. Available Manufacturers:
 - a. Capitol Manufacturing Co.
 - b. Central Plastics Company.
 - c. Epco Sales, Inc.
 - d. Watts Industries, Inc.; Water Products Div.

- E. Dielectric-Flange Kits: Companion-flange assembly for field assembly. Include flanges, full-face- or ring-type neoprene or phenolic gasket, phenolic or polyethylene bolt sleeves, phenolic washers, and steel backing washers.
 - 1. Available Manufacturers:
 - a. Advance Products & Systems, Inc.
 - b. Calpico, Inc.
 - c. Central Plastics Company.
 - d. Pipeline Seal and Insulator, Inc.
 - 2. Separate companion flanges and steel bolts and nuts shall have 150- or 300-psig minimum working pressure where required to suit system pressures.

- F. Dielectric Couplings: Galvanized-steel coupling with inert and noncorrosive, thermoplastic lining; threaded ends; and 300-psig minimum working pressure at 225deg. F.
 - 1. Available Manufacturers:
 - a. Calpico, Inc.
 - b. Lochinvar Corp.

- G. Dielectric Nipples: Electroplated steel nipple with inert and noncorrosive, thermoplastic lining; plain, threaded, or grooved ends; and 300-psig minimum working pressure at 225 deg F.
 - 1. Available Manufacturers:
 - a. Perfection Corp.
 - b. Precision Plumbing Products, Inc.
 - c. Sioux Chief Manufacturing Co., Inc.
 - d. Victaulic Co. of America.

2.6 MECHANICAL SLEEVE SEALS

- A. Description: Modular sealing element unit, designed for field assembly, to fill annular space between pipe and sleeve.
 - 1. Available Manufacturers:
 - a. Advance Products & Systems, Inc.
 - b. Calpico, Inc.
 - c. Metraflex Co.
 - d. Pipeline Seal and Insulator, Inc.

2. Sealing Elements: EPDM interlocking links shaped to fit surface of pipe. Include type and number required for pipe material and size of pipe.
3. Pressure Plates: Plastic. Include two for each sealing element.
4. Connecting Bolts and Nuts: Carbon steel with corrosion-resistant coating of length required to secure pressure plates to sealing elements. Include one for each sealing element.

2.7 SLEEVES

- A. Galvanized-Steel Sheet: 0.0239-inch minimum thickness; round tube closed with welded longitudinal joint.
- B. Steel Pipe: ASTM A 53, Type E, Grade B, Schedule 40, galvanized, plain ends.
- C. Cast Iron: Cast or fabricated "wall pipe" equivalent to ductile-iron pressure pipe, with plain ends and integral waterstop, unless otherwise indicated.
- D. Stack Sleeve Fittings: Manufactured, cast-iron sleeve with integral clamping flange. Include clamping ring and bolts and nuts for membrane flashing.
 1. Underdeck Clamp: Clamping ring with set screws.
- E. Molded PVC: Permanent, with nailing flange for attaching to wooden forms.
- F. PVC Pipe: ASTM D 1785, Schedule 40.
- G. Molded PE: Reusable, PE, tapered-cup shaped, and smooth-outer surface with nailing flange for attaching to wooden forms.

2.8 ESCUTCHEONS

- A. Description: Manufactured wall and ceiling escutcheons and floor plates, with an ID to closely fit around pipe, tube, and insulation of insulated piping and an OD that completely covers opening.
- B. One-Piece, Deep-Pattern Type: Deep-drawn, box-shaped brass with polished chrome-plated finish.
- C. One-Piece, Cast-Brass Type: With set screw.
 1. Finish: Polished chrome-plated.
- D. Split-Casting, Cast-Brass Type: With concealed hinge and set screw.
 1. Finish: Polished chrome-plated.

- E. One-Piece, Stamped-Steel Type: With set screw or spring clips and chrome-plated finish.
- F. One-Piece, Floor-Plate Type: Cast-iron floor plate.
- G. Split-Casting, Floor-Plate Type: Cast brass with concealed hinge and set screw.

2.9 GROUT

- A. Description: ASTM C 1107, Grade B, nonshrink and nonmetallic, dry hydraulic-cement grout.
 - 1. Characteristics: Post-hardening, volume-adjusting, nonstaining, noncorrosive, nongaseous, and recommended for interior and exterior applications.
 - 2. Design Mix: 5000-psi, 28-day compressive strength.
 - 3. Packaging: Premixed and factory packaged.

PART 3 - EXECUTION

3.1 HVAC DEMOLITION

- A. Refer to Division 01 Section "Cutting and Patching" and Division 02 Section "Selective Structure Demolition" for general demolition requirements and procedures.
- B. Disconnect, demolish, and remove HVAC systems, equipment, and components indicated to be removed.
 - 1. Piping to Be Removed: Remove portion of piping indicated to be removed and cap or plug remaining piping with same or compatible piping material.
 - 2. Piping to Be Abandoned in Place: Drain piping and cap or plug piping with same or compatible piping material.
 - 3. Ducts to Be Removed: Remove portion of ducts indicated to be removed and plug remaining ducts with same or compatible ductwork material.
 - 4. Ducts to Be Abandoned in Place: Cap or plug ducts with same or compatible ductwork material.
 - 5. Equipment to Be Removed: Disconnect and cap services and remove equipment.
 - 6. Equipment to Be Removed and Reinstalled: Disconnect and cap services and remove, clean, and store equipment; when appropriate, reinstall, reconnect, and make equipment operational.
 - 7. Equipment to Be Removed and Salvaged: Disconnect and cap services and remove equipment and deliver to Owner.
- C. If pipe, insulation, or equipment to remain is damaged in appearance or is unserviceable, remove damaged or unserviceable portions and replace with new products of equal capacity and quality.

3.2 PIPING SYSTEMS - COMMON REQUIREMENTS

- A. Install piping according to the following requirements and Division 23 Sections specifying piping systems.
- B. Drawing plans, schematics, and diagrams indicate general location and arrangement of piping systems. Indicated locations and arrangements were used to size pipe and calculate friction loss, expansion, pump sizing, and other design considerations. Install piping as indicated unless deviations to layout are approved on Coordination Drawings.
- C. Install piping in concealed locations, unless otherwise indicated and except in equipment rooms and service areas.
- D. Install piping indicated to be exposed and piping in equipment rooms and service areas at right angles or parallel to building walls. Diagonal runs are prohibited unless specifically indicated otherwise.
- E. Install piping above accessible ceilings to allow sufficient space for ceiling panel removal.
- F. Install piping to permit valve servicing.
- G. Install piping at indicated slopes.
- H. Install piping free of sags and bends.
- I. Install fittings for changes in direction and branch connections.
- J. Install piping to allow application of insulation.
- K. Select system components with pressure rating equal to or greater than system operating pressure.
- L. Install escutcheons for penetrations of walls, ceilings, and floors according to the following:
 - 1. New Piping:
 - a. Piping with Fitting or Sleeve Protruding from Wall: One-piece, deep-pattern type.
 - b. Chrome-Plated Piping: One-piece, cast-brass type with polished chrome-plated finish.
 - c. Insulated Piping: One-piece, stamped-steel type with spring clips.
 - d. Bare Piping at Wall and Floor Penetrations in Finished Spaces: One-piece, cast-brass type with polished chrome-plated finish.
 - e. Bare Piping at Wall and Floor Penetrations in Finished Spaces: One-piece, stamped-steel type.
 - f. Bare Piping at Ceiling Penetrations in Finished Spaces: One-piece or split-casting, cast-brass type with polished chrome-plated finish.

- g. Bare Piping at Ceiling Penetrations in Finished Spaces: One-piece, stamped-steel type and set screw.
 - h. Bare Piping in Unfinished Service Spaces: One-piece, cast-brass type with polished chrome-plated finish.
 - i. Bare Piping in Unfinished Service Spaces: One-piece, stamped-steel type with concealed hinge and set screw.
 - j. Bare Piping in Equipment Rooms: One-piece, cast-brass type.
 - k. Bare Piping in Equipment Rooms: One-piece, stamped-steel type with set screw or spring clips.
 - l. Bare Piping at Floor Penetrations in Equipment Rooms: One-piece, floor-plate type.
2. Existing Piping: Use the following:
- a. Chrome-Plated Piping: Split-casting, cast-brass type with chrome-plated finish.
 - b. Insulated Piping: Split-plate, stamped-steel type with concealed hinge and spring clips.
 - c. Bare Piping at Wall and Floor Penetrations in Finished Spaces: Split-casting, cast-brass type with chrome-plated finish.
 - d. Bare Piping at Wall and Floor Penetrations in Finished Spaces: Split-plate, stamped-steel type with concealed hinge and spring clips.
 - e. Bare Piping at Ceiling Penetrations in Finished Spaces: Split-casting, cast-brass type with chrome-plated finish.
 - f. Bare Piping at Ceiling Penetrations in Finished Spaces: Split-plate, stamped-steel type with concealed hinge and set screw.
 - g. Bare Piping in Unfinished Service Spaces: Split-casting, cast-brass type with polished chrome-plated finish.
 - h. Bare Piping in Unfinished Service Spaces: Split-plate, stamped-steel type with concealed or exposed-rivet hinge and set screw or spring clips.
 - i. Bare Piping in Equipment Rooms: Split-casting, cast-brass type.
 - j. Bare Piping in Equipment Rooms: Split-plate, stamped-steel type with set screw or spring clips.
 - k. Bare Piping at Floor Penetrations in Equipment Rooms: Split-casting, floor-plate type.
- M. Sleeves are not required for core-drilled holes.
- N. Permanent sleeves are not required for holes formed by removable PE sleeves.
- O. Install sleeves for pipes passing through concrete and masonry walls and concrete floor and roof slabs.
- P. Install sleeves for pipes passing through concrete and masonry walls, gypsum-board partitions, and concrete floor and roof slabs.
- 1. Cut sleeves to length for mounting flush with both surfaces.

- a. Exception: Extend sleeves installed in floors of mechanical equipment areas or other wet areas **2 inches** above finished floor level. Extend cast-iron sleeve fittings below floor slab as required to secure clamping ring if ring is specified.
 2. Install sleeves in new walls and slabs as new walls and slabs are constructed.
 3. Install sleeves that are large enough to provide **1/4-inch** annular clear space between sleeve and pipe or pipe insulation. Use the following sleeve materials:
 - a. Steel Pipe Sleeves: For pipes smaller than **NPS 6**.
 - b. Steel Sheet Sleeves: For pipes **NPS 6** and larger, penetrating gypsum-board partitions.
 - c. Stack Sleeve Fittings: For pipes penetrating floors with membrane waterproofing. Secure flashing between clamping flanges. Install section of cast-iron soil pipe to extend sleeve to **2 inches** above finished floor level. Refer to Division 07 Section "Sheet Metal Flashing and Trim" for flashing.
 - 1) Seal space outside of sleeve fittings with grout.
 4. Except for underground wall penetrations, seal annular space between sleeve and pipe or pipe insulation, using joint sealants appropriate for size, depth, and location of joint. Refer to Division 07 Section "Joint Sealants" for materials and installation.
- Q. Aboveground, Exterior-Wall Pipe Penetrations: Seal penetrations using sleeves and mechanical sleeve seals. Select sleeve size to allow for **1-inch** annular clear space between pipe and sleeve for installing mechanical sleeve seals.
1. Install steel pipe for sleeves smaller than **6 inches** in diameter.
 2. Install cast-iron "wall pipes" for sleeves **6 inches** and larger in diameter.
 3. Mechanical Sleeve Seal Installation: Select type and number of sealing elements required for pipe material and size. Position pipe in center of sleeve. Assemble mechanical sleeve seals and install in annular space between pipe and sleeve. Tighten bolts against pressure plates that cause sealing elements to expand and make watertight seal.
- R. Underground, Exterior-Wall Pipe Penetrations: Install cast-iron "wall pipes" for sleeves. Seal pipe penetrations using mechanical sleeve seals. Select sleeve size to allow for **1-inch** annular clear space between pipe and sleeve for installing mechanical sleeve seals.mm)
1. Mechanical Sleeve Seal Installation: Select type and number of sealing elements required for pipe material and size. Position pipe in center of sleeve. Assemble mechanical sleeve seals and install in annular space between pipe and sleeve. Tighten bolts against pressure plates that cause sealing elements to expand and make watertight seal.

- S. Fire-Barrier Penetrations: Maintain indicated fire rating of walls, partitions, ceilings, and floors at pipe penetrations. Seal pipe penetrations with firestop materials. Refer to Division 07 Section "Penetration Firestopping" for materials.
- T. Verify final equipment locations for roughing-in.
- U. Refer to equipment specifications in other Sections of these Specifications for roughing-in requirements.

3.3 PIPING JOINT CONSTRUCTION

- A. Join pipe and fittings according to the following requirements and Division 23 Sections specifying piping systems.
- B. Ream ends of pipes and tubes and remove burrs. Bevel plain ends of steel pipe.
- C. Remove scale, slag, dirt, and debris from inside and outside of pipe and fittings before assembly.
- D. Soldered Joints: Apply ASTM B 813, water-flushable flux, unless otherwise indicated, to tube end. Construct joints according to ASTM B 828 or CDA's "Copper Tube Handbook," using lead-free solder alloy complying with ASTM B 32.
- E. Brazed Joints: Construct joints according to AWS's "Brazing Handbook," "Pipe and Tube" Chapter, using copper-phosphorus brazing filler metal complying with AWS A5.8.
- F. Threaded Joints: Thread pipe with tapered pipe threads according to ASME B1.20.1. Cut threads full and clean using sharp dies. Ream threaded pipe ends to remove burrs and restore full ID. Join pipe fittings and valves as follows:
 - 1. Apply appropriate tape or thread compound to external pipe threads unless dry seal threading is specified.
 - 2. Damaged Threads: Do not use pipe or pipe fittings with threads that are corroded or damaged. Do not use pipe sections that have cracked or open welds.
- G. Welded Joints: Construct joints according to AWS D10.12, using qualified processes and welding operators according to Part 1 "Quality Assurance" Article.
- H. Flanged Joints: Select appropriate gasket material, size, type, and thickness for service application. Install gasket concentrically positioned. Use suitable lubricants on bolt threads.
- I. Plastic Piping Solvent-Cement Joints: Clean and dry joining surfaces. Join pipe and fittings according to the following:

1. Comply with ASTM F 402 for safe-handling practice of cleaners, primers, and solvent cements.
2. CPVC Piping: Join according to ASTM D 2846/D 2846M Appendix.
3. PVC Pressure Piping: Join schedule number ASTM D 1785, PVC pipe and PVC socket fittings according to ASTM D 2672. Join other-than-schedule-number PVC pipe and socket fittings according to ASTM D 2855.
4. PVC Nonpressure Piping: Join according to ASTM D 2855.

J. Plastic Pressure Piping Gasketed Joints: Join according to ASTM D 3139.

K. Plastic Nonpressure Piping Gasketed Joints: Join according to ASTM D 3212.

L. PE Piping Heat-Fusion Joints: Clean and dry joining surfaces by wiping with clean cloth or paper towels. Join according to ASTM D 2657.

1. Plain-End Pipe and Fittings: Use butt fusion.
2. Plain-End Pipe and Socket Fittings: Use socket fusion.

M. Fiberglass Bonded Joints: Prepare pipe ends and fittings, apply adhesive, and join according to pipe manufacturer's written instructions.

3.4 PIPING CONNECTIONS

A. Make connections according to the following, unless otherwise indicated:

1. Install unions, in piping **NPS 2** and smaller, adjacent to each valve and at final connection to each piece of equipment.
2. Install flanges, in piping **NPS 2-1/2** and larger, adjacent to flanged valves and at final connection to each piece of equipment.
3. Dry Piping Systems: Install dielectric unions and flanges to connect piping materials of dissimilar metals.
4. Wet Piping Systems: Install dielectric coupling and nipple fittings to connect piping materials of dissimilar metals.

3.5 EQUIPMENT INSTALLATION - COMMON REQUIREMENTS

- A. Install equipment to allow maximum possible headroom unless specific mounting heights are not indicated.
- B. Install equipment level and plumb, parallel and perpendicular to other building systems and components in exposed interior spaces, unless otherwise indicated.
- C. Install HVAC equipment to facilitate service, maintenance, and repair or replacement of components. Connect equipment for ease of disconnecting, with minimum interference to other installations. Extend grease fittings to accessible locations.
- D. Install equipment to allow right of way for piping installed at required slope.

3.6 PAINTING

- A. Painting of HVAC systems, equipment, and components is specified in Division 09 Sections "Interior Painting" and "Exterior Painting."
- B. Damage and Touchup: Repair marred and damaged factory-painted finishes with materials and procedures to match original factory finish.

3.7 CONCRETE BASES

- A. Concrete Bases: Anchor equipment to concrete base according to equipment manufacturer's written instructions and according to seismic codes at Project.
 - 1. Construct concrete bases of dimensions indicated, but not less than 4 inches larger in both directions than supported unit.
 - 2. Install dowel rods to connect concrete base to concrete floor. Unless otherwise indicated, install dowel rods on 18-inch centers around the full perimeter of the base.
 - 3. Install epoxy-coated anchor bolts for supported equipment that extend through concrete base, and anchor into structural concrete floor.
 - 4. Place and secure anchorage devices. Use supported equipment manufacturer's setting drawings, templates, diagrams, instructions, and directions furnished with items to be embedded.
 - 5. Install anchor bolts to elevations required for proper attachment to supported equipment.
 - 6. Install anchor bolts according to anchor-bolt manufacturer's written instructions.
 - 7. Use 3000-psi, 28-day compressive-strength concrete and reinforcement as specified in Division 03 Section "Cast-in-Place Concrete."

3.8 ERECTION OF METAL SUPPORTS AND ANCHORAGES

- A. Refer to Division 05 Section "Metal Fabrications" for structural steel.
- B. Cut, fit, and place miscellaneous metal supports accurately in location, alignment, and elevation to support and anchor HVAC materials and equipment.
- C. Field Welding: Comply with AWS D1.1.

3.9 ERECTION OF WOOD SUPPORTS AND ANCHORAGES

- A. Cut, fit, and place wood grounds, nailers, blocking, and anchorages to support, and anchor HVAC materials and equipment.
- B. Select fastener sizes that will not penetrate members if opposite side will be exposed to view or will receive finish materials. Tighten connections between members. Install fasteners without splitting wood members.

- C. Attach to substrates as required to support applied loads.

3.10 GROUTING

- A. Mix and install grout for HVAC equipment base bearing surfaces, pump and other equipment base plates, and anchors.
- B. Clean surfaces that will come into contact with grout.
- C. Provide forms as required for placement of grout.
- D. Avoid air entrapment during placement of grout.
- E. Place grout, completely filling equipment bases.
- F. Place grout on concrete bases and provide smooth bearing surface for equipment.
- G. Place grout around anchors.
- H. Cure placed grout.

END OF DOCUMENT

P-SERIES

PLA-A24BA6 & PUZ-A24NHA6 (-BS) 24,000 BTU/H CEILING CASSETTE HEAT-PUMP SYSTEM



Job Name: _____

System Reference: _____ Date: _____



Indoor Unit: PLA-A24BA6



Outdoor Unit: PUZ-A24NHA6 (-BS)

UNIT OPTION:

- Standard Model.....PUZ-A24NHA6
- Seacoast (BS) Model.....PUZ-A24NHA6-BS

ACCESSORIES:

Indoor Unit

- Condensate Pump (BlueDiamond X87-711/721; 115/230V)
- Condensate Pump (Sauermann SI30-115/230; 115/230V)
- iSee Corner Panel (PAC-SA1ME-E)
- Multifunction Casement / MERV 10 Filter (PAC-SH53TM-E / PAC-SH59KF)
- Air Outlet Plates (PAC-SH51SP-E)

Outdoor Unit

- Wind Baffle (WB-PA2)*
*Allows operation to 0° F (-18° C).
- Air Outlet Guide (PAC-SG59SG-E)
- Mounting Base (QSMS1201)
- Wall Bracket (QSWB2000M-1)

Controls

- Wireless Controller (MHK1)
- Advanced Wired Controller (PAR-31MAA)
- Simple Wired Controller (PAC-YT53CRAU)
- M-NET Adapter (PAC-SF83MA-E)
- Temperature Sensor (PAC-SE41TS)

SPECIFICATIONS:

Rated Conditions (Capacity / Input)*		
Cooling	Blu/h / W	24,000 / 2,500
Heating at 47° F	Blu/h / W	26,000 / 2,570
Heating at 17° F	Blu/h / W	16,000 / 2,200

* Rating Conditions per AHRI Standard:
Cooling | Indoor: 80° F (27° C)DB / 67° F (19° C)WB; Outdoor: 95° F (35° C)DB / 75° F (24° C)WB
Heating at 47° F | Indoor: 70° F (21° C)DB / 60° F (16° C)WB; Outdoor: 47° F (8° C)DB / 43° F (6° C)WB
Heating at 17° F | Indoor: 70° F (21° C)DB / 60° F (16° C)WB; Outdoor: 17° F (-8° C)DB / 15° F (-9° C)WB

Capacity Range		
Cooling	Blu/h	12,000 - 24,000
Heating at 47° F	Blu/h	12,000 - 28,000

Operating Range	
Cooling	0° F** to 115° F (-18° C to 46° C) DB
Heating	12° F to 70° F (-11° C to 21° C) DB

** The minimum temperature will be 23° F (-5° C) DB if optional wind baffle accessory is not installed.

AHRI Efficiency Ratings	
EER	9.6
SEER	14.0
HSPF	8.5
COP at 47° F	2.96
COP at 17° F	2.14

Electrical Power Requirements	208 / 230V, 1-Phase, 60 Hz
-------------------------------	----------------------------

Minimum Circuit Ampacity (MCA)		
Indoor / Outdoor	A	1 / 18

Indoor Unit		
Fan Motor (ECM)	F.L.A.	0.51
Fan Motor Output	W	50
SHF / Moisture Removal		0.76 / 5.1 pt./h
Drain Lift Mechanism (Included)	H: In.	33-7/16

Outdoor Unit		
Compressor		DC INVERTER-driven Twin Rotary
Fan Motor (ECM)	F.L.A.	0.75
MOCP	A	30

Airflow Rate (Low-M1-M2-Hi)			
Indoor (Cooling)	DRY	CFM	420-490-570-640
	WET		390-460-530-600
Outdoor	DRY		1,940

Sound Pressure Level			
Indoor (Low-M1-M2-Hi)		dB(A)	28-29-31-32
Outdoor	Cooling		48
	Heating		50

External Dimensions		
Indoor (H x W x D)	In.(mm)	10-3/16 x 33-1/16 x 33-1/16 (258 x 840 x 840)
Outdoor (H x W x D)		37-1/8 x 37-3/8 x 13 + 1-3/16 (943 x 950 x 330 + 30)

Net Weight		
Indoor (Unit / Grille)	Lbs.(kg)	51 / 13 (23 / 6)
Outdoor		165 (75)

External Finish	
Indoor	Munsell No. 6.4Y 8.9/0.4
Outdoor	Munsell No. 3Y 7.8 / 1.1

Refrigerant	R410A ; 6lbs., 10oz.
-------------	----------------------

Refrigerant Piping (Flared)		
Liquid (High Pressure)	In.(mm)	3/8 (9.52)
Gas (Low Pressure)		5/8 (15.88)
Maximum Total Refrigerant Pipe Length	Ft. (m)	165 (50)
Maximum Vertical Separation	Ft. (m)	100 (30)

Job Name:	Date:
System Reference:	

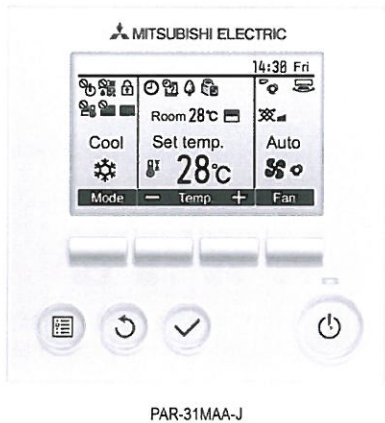

SPECIFICATIONS:

- Controls group operation for up to 16 indoor units in a single group
- Features selectable multi-lingual LCD (English, Spanish, and French)
- Supports both Fahrenheit and Celsius
- User functions allow user to set
 - On/Off
 - Operation modes cool, heat, dry, fan
 - Set temperature
 - Fan speed setting
 - Airflow direction
- Timer Operation:
 - Weekly Timer: On/Off/Temperature setting up to 8 times per day of the week in 1-minute increments
 - Simple Timer: On and Off time can be set once within 72-hour period in 1-hour increments
 - Auto-off Timer: Turns indoor unit Off based on countdown time up to 4-hours in 30-minute increments
- Room Temperature: Displays room temperature sensed either at the indoor unit (default) or at the remote controller
- Set Temperature Range Limit: From the Backlit MA Controller, the allowable set temperature range can be reduced for cool and heat modes
- Supplemental heat function enable/disable
- Function Lock Out: Prohibits all functions or all functions except On/Off from the backlit MA controller
- Addressing: No addressing required
- Wiring: connects using two-wire, stranded, non-polar control wire to indoor unit connection terminal
- Dimensions: 4-3/4 x 3/4 x 4-3/4" (120 x 19 x 120 mm)

DIMENSIONS:

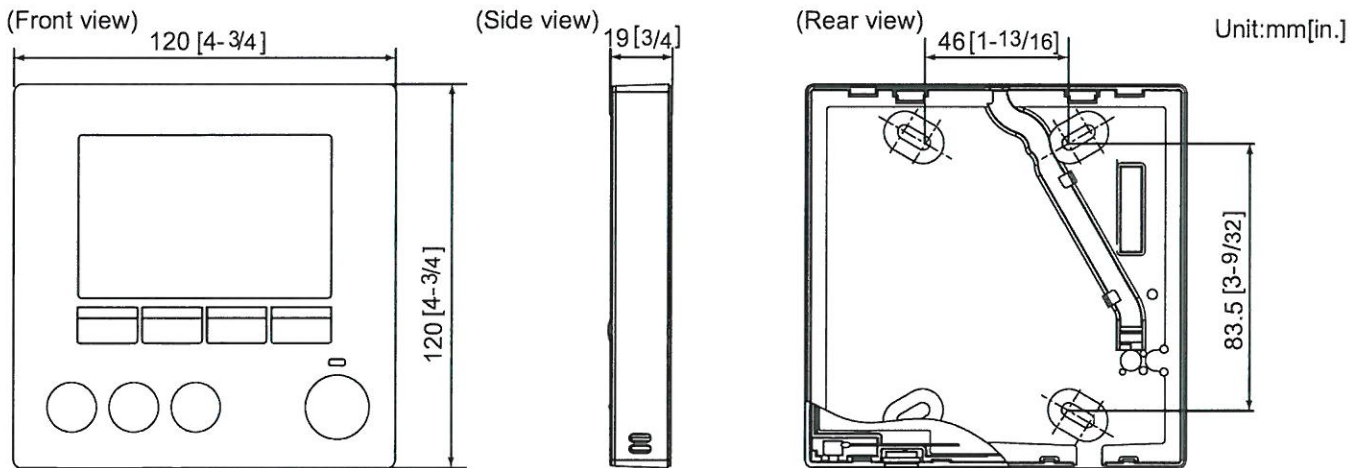

COOLING & HEATING

1340 Satellite Boulevard, Suwanee, GA 30024
Toll Free: 800-433-4822 www.mehvac.com

