

# Aristokraft®

CABINETS

1954



## 2014 : SPECIFICATION GUIDE

Effective February 24, 2014



## NEW PRODUCTS





- ▶ **3/4" Shelf on All Wall Cabinets**
- ▶ **6-Way Adjustable Hinge on All Door Styles**
- ▶ **Benton Now PLUS Door Style - Butt Door Cabinets Available**
- ▶ **Westbury Oak Arch Now in Same Price Bucket as Westbury Oak Square**
- ▶ **Profile Change on Briarcliff Door Style - Now Briarcliff II**
- ▶ **Additional 12" and 14" High Wall Cabinets**
- ▶ **Additional 15" Deep Wall Cabinets**
- ▶ **Additional 12" and 15" Deep Wall Open Cabinets, Wall Cabinets with Mullion Doors, and Wall Cabinets with Doors Prepped for Glass**
- ▶ **Additional 12", 14" and 18" High Refrigerator Wall Cabinets**
- ▶ **Additional 36" High Square Corner Wall Cabinets**
- ▶ **12" and 15" Deep Base Open Cabinets**
- ▶ **6" Wide Base Box Column Pullout Cabinet and Optional Overlay**
- ▶ **Removable Vanity Wall Sink Cabinets**
- ▶ **96" Tall Fillers**
- ▶ **Veneer End Panels Now a Case Pack of One**
- ▶ **Simplified Upgrade Pricing Charts**





# TABLE OF CONTENTS

Product Code Index .....	2-3
Door Style Numbers .....	4-6
Common Style Numbers for Finishes .....	7
Door Styles .....	8-16
Core-Plus Details .....	17
Standard, Select, & All Plywood Construction Options .....	18-19
Finish Availability/Finishing Process .....	20
Ordering Information .....	21
Characteristics of Wood .....	22
Characteristics of Paint and Laminate/Humidification Effects .....	23
Mullion Door Information .....	24
Cabinet Specifications .....	25-28
Design Checklist/Tips to the Installer .....	29
NKBA Guidelines .....	30-31
Organization Solutions .....	32
Room Solutions .....	33-35
Moulding Solutions .....	36-37
Wall Cabinets .....	38-77
Base Cabinets .....	78-94
Tall Cabinets .....	95-106
Other Room Cabinets .....	107-109
Vanity Cabinets .....	110-129
Universal Design Cabinets .....	130-134
Mouldings & Trim .....	135-153
Accessories & Parts .....	154-172
Warped Door Policy/Cabinet Care Suggestions .....	173
Policies/Information .....	174
Warranty .....	Inside Back Cover



Code	Description	Page	Code	Description	Page
AC	Appliance Center	154	HEATSHIELDAN	Angled Heat Shield	159
ACOVLY	Acanthus Overlay	144	HEATSHIELDST	Straight Heat Shield	159
APDWR	Apothecary Drawer	156	HINGE6WAY	6-way Adjustable Hinge	164
B	Base Cabinet	78	ISLEG	Island Leg	146
B..32.5	Base Cabinet Universal Design	130	KDT	Kneespace Drawer	109
B..B	Base Cabinet w/Butt Doors	78	KTT	Keyboard Tray	109
B..32.5B	Base Cabinet w/Butt Doors Universal Design	130	LCD	Linen Closet w/Drawer	124
B..FH	Base Cabinet w/Full Height Doors	81	LCD..SC	Linen Closet SuperCabinet™ w/Removable Hamper	125
B..32.5FH	Base Cabinet w/Full Height Doors Universal Design	130	LGCORBEL	Large Corbel	145
B..FHB	Base Cabinet w/Full Height Butt Doors	81	LKS	Linen Closet Shelf Kit	127
B..32.5FHB	Base Cabinet w/Full Height Butt Doors Universal Design	130	LTOT	Lavatory Tip-Out Tray	127
B..FH-12	Base Cabinet w/Full Height Doors, 12" Deep	81	MBAT	Batten Moulding	138
B..FH-12B	Base Cabinet w/Full Height Butt Doors, 12" Deep	81	MBS	Base Shoe Moulding	140
B..RT-2	Base Cabinet w/Double Roll Tray	79	MCROWN	Crown Moulding	136
B..RT	Base Cabinet w/Roll Tray	78	MCTB	Counter Top Moulding Bevel	137
B..RT2B	Base Cabinet w/Double Roll Trays & Butt Doors	79	MCTOG	Counter Top Moulding Ogee	137
B..RTB	Base Cabinet w/Roll Tray & Butt Doors	79	MCTR	Counter Top Moulding Radius	137
B..RT-2LO	Base Cabinet w/Double Roll Tray & Lid Organizer	79	MCV	Cove Moulding	138
B..RT-2LOB	Base Cabinet w/Double Roll Tray, Lid Organizer, & Butt Doors	79	MDENTIL	Dentil Moulding	140
B..TDRO	Base Cabinet w/Roll Out Tray Divider	82	MFOLCR	Full Overlay Crown Moulding	136
BBCPO	Base Box Column Pullout Cabinet	81	MICROWN	Insert Crown Moulding	136
BEC	Base End Cabinet	92	MLR	Light Rail Moulding	139
BK	Bookcase	107	MOCW	Outside Corner Moulding	135
BKB	Bookcase Base	108	MQR	Quarter Round Moulding	138
BKB..B	Bookcase Base w/Butt Doors	108	MROPE	Rope Moulding	140
BKSHELFKIT	Bookshelf Kit	154	MSFM	Soffit Filler Moulding	137
BLS	Base Lazy Susan	90	MSHKRCROWN	Shaker Crown Moulding	136
BLS..32.5	Base Lazy Susan Universal Design	132	MSMCOVECR	Small Cove Crown Moulding	136
BLVDFF	Angled Fluted Filler	141	MSTR	Starter Moulding	137
BMW	Base Built-In Microwave Cabinet	89	MSW	Wood Scribe Moulding	135
BMW..32.5	Base Built-In Microwave Cabinet Universal Design	133	MTBAT	Traditional Batten Moulding	140
BOL	Base Open Cabinet	146	MTBEAD	Triple Bead Moulding	135
BP	Beadboard Panel	149	MTCAP	Traditional Cap Moulding	139
BPP	Base Pantry Pullout Cabinet	82	MTCROWN	Tall Crown Moulding	136
BPPP	Base Pots & Pans Pullout	83	MTLR	Tall Light Rail Moulding	139
BRER	Base Roto Easy Reach Cabinet	89	MTST	Traditional Soffit Trim Moulding	138
BSC..PR	Base SuperCabinet™ Pullout/Roll Out	80	MTT	Traditional Trim Moulding	139
BSC..PRB	Base SuperCabinet™ Pullout/Roll Out w/Butt Doors	80	MWC	Microwave Wall Cabinet	60
BSC..PRP	Base SuperCabinet™ Pullout/Roll Out/Pullout	80	MWC..B	Microwave Wall Cabinet w/Butt Doors	60
BSC..PRPB	Base SuperCabinet™ Pullout/Roll Out/Pullout w/Butt Doors	80	MWS	Microwave Shelf Unit	62
BSC..RP	Base SuperCabinet™ Roll Out/Pullout	80	OC	Oven Cabinet	95
BSC..RPB	Base SuperCabinet™ Roll Out/Pullout w/Butt Doors	80	OC..B	Oven Cabinet w/Butt Doors	95
BWB	Base Wastebasket	84	OCD	Double Oven Cabinet	98
BWB..FH	Base Wastebasket w/Full Height Doors	83	OCD..B	Double Oven Cabinet w/Butt Doors	98
CBK	Cutting Board Kit	157	OCINSTALLKIT	Oven Installation Kit	160
CNTYSB	Country Sink Base	85	OL	Overlay	142
CNTYSB..B	Country Sink Base w/Butt Doors	85	ORG	Organizer Shelves	155
CORBELART	Art Corbel	144	P	Veneer Stock Panel	149
CORBELMIS	Mission Corbel	145	PA	Aristex® Laminate Stock Panel	149
CT	Cutlery Tray	157	PB	Peninsula Base	93
DB	Three Drawer Base	88	PB..B	Peninsula Base w/Butt Doors	93
DB..32.5	Three Drawer Base Universal Design	132	PBSC	Peninsula Base Square Corner Cabinet	93
DB-4	Four Drawer Base	87	PBSC..B	Peninsula Base Square Corner Cabinet w/Butt Doors	93
DBEP	Decorative Base End Panel	151	PDC	Diagonal Corner Peninsula Wall Cabinet	77
DBFP	Three Drawer Base w/False Panel	88	PDO	Pegged Dish Organizer	157
DBFP-4	Four Drawer Base w/False Panel	88	PDOPOSTS	Pegged Dish Organizer Posts	157
DC	Diagonal Corner Wall Cabinet	65	PDWP	Dishwasher Panel	148
DCMD	Diagonal Corner Wall w/Mullion Doors	68	PEPR	End Panel w/Stile	148
DCOL	Diagonal Corner Wall Open Cabinet	66	PEPRPLY	Plywood End Panel w/Stile	148
DCPG	Diagonal Corner Wall Prepped for Glass	69	PKS	Pantry Shelf Kit	161
DCR	Diagonal Corner Roto Wall Cabinet	71	PREF	Refrigerator End Panel	148
DDWP	Decorative Dishwasher Panel	151	PREPR	Refrigerator End Panel w/Stile	148
DLEGMISION	Decorative Mission Leg	146	PREPRP	Plywood Refrigerator End Panel w/Stile	148
DPBEP	Decorative Peninsula Base End Panel	151	PSC	Pantry SuperCabinet™	101
DUEP	Decorative Utility End Panel	151	PSC..B	Pantry SuperCabinet™ w/Butt Doors	101
DVEP	Decorative Vanity End Panel	151	PSFEP	Sink Front End Panel	148
DWBR	Double Wastebasket Roll Out	163	PW	Peninsula Wall Cabinet	75
DWEP	Decorative Wall End Panel	151	PW..B	Peninsula Wall Cabinet w/Butt Doors	75
ENGBARCOLUMN	English Bar Column Leg	146	PWMD	Peninsula Wall Cabinet w/Mullion Doors	76
ENGISLCOLUMN	English Island Column Leg	146	PWMD..B	Peninsula Wall Cabinet w/Mullion Butt Doors	76
EPA	Laminate End Panel	150	PWPG	Peninsula Wall Cabinets w/Doors Prepped for Glass	77
EPCBFL	End Panel Column Base, Fluted	152	PWPG..B	Peninsula Wall Cabinets w/Butt Doors Prepped for Glass	77
EPCBRD	End Panel Column Base, Round	152	RDLEG	Reed Leg	146
EPCBRE	End Panel Column Base, Reeded	152	REED	Split Turning Reed	143
EPV	Veneer End Panel	150	ROSETTEMIS	Mission Rosette	143
F	Filler	141	RP	Range Panel	152
F..A	Decorative Angled/Fluted/Plain Filler	141	RTBP	Roll Tray Bumper Pad	163
FBC	Base Corner Filler	141	RVWS	Removable Vanity Wall Sink	134
FF	Filler Reeded	141	RW	Refrigerator Wall Cabinet	56
FFL	Filler Fluted	141	RW..B	Refrigerator Wall Cabinet w/Butt Doors	56
FFROS	Rosette	244	SB	Sink/Range Base	84
FILTER	Filter for Wood Hood Blower	65	SB..32.5	Sink Base Universal Design	131
FRNLEG	French Leg	146	SB..B	Sink/Range Base w/Butt Doors	84
GSK	Glass Shelf Kit	158	SB..32.5B	Sink Base w/Butt Doors Universal Design	131
GSKDC	Diagonal Glass Shelf Kit	158	SB..STS	Sink Base SuperCabinet™	85
			SB..STSB	Sink Base SuperCabinet™ w/Butt Doors	85
			SBDC	Sink Base Diagonal Corner Cabinet	86
			SC	Square Corner Wall Cabinet	72



Code	Description	Page
SC..B	Square Corner Wall Cabinet w/Butt Doors	72
SCB	Square Corner Base	91
SCB..32.5	Square Corner Base Universal Design	133
SCER	Square Corner/Base Roto Easy Reach Cabinet	89
SCR	Square Corner Roto Base	90
SCR..32.5	Square Corner Roto Base Universal Design	132
SF	Sink/Range Front	86
SF..32.5	Sink Front Universal Design	131
SF..B	Sink/Range Front w/Butt Doors	86
SF..32.5B	Sink Front w/Butt Doors Universal Design	131
SFC	Sink Front Corner	87
SGH	Stem Glass Holder	154
SMCORBEL	Small Corbel	145
SPACER4	Hinge Spacer	164
SPOOL	Split Turning Spool	143
SPRINGEND	Split Turning End	143
SRD	Wall Spice Rack	156
SSDM	Smart Stop™ Doors Mechanism	164
STAINPT	Pint of Stain	165
STAINQT	Quart of Stain	165
STOT..WH	Sink Tip-Out Tray, 2 Fronts	163
STOT..WHB	Sink Tip-Out Tray, 1 Front	163
SU..32.5	Sink Unit w/Front Panel Universal Design	131
TAPLEG	Tapered Leg	146
TKC	Toekick Cap	153
TKF	Toekick Filler	141
TKIT	Roll Tray Kit	162
TKTLFOOT	Toekick Tulip Foot	146
TOEKICK	Toekick	153
TONERPT	Pint of Toner	165
TUKIT	Touch-Up Kit	165
TUPSPRAY	Touch-Up Spray Can	165
TUPSTICK	Touch-Up Stick	165
TWH	Tapered Wood Hood	64
TWHBLOWER	Wood Hood Blower	64
TWHCONVKIT	Wood Hood Conversion Kit	64
U	Utility Cabinet	104
U..B	Utility Cabinet w/Butt Doors	104
UPK	Pantry Roll Tray Kit	162
V..RA	Valance Arch	147
V..SC	Valance Scalloped	147
V..ST	Valance Straight	147
VB	Vanity Base	110
VB..B	Vanity Base w/Butt Doors	111
VBP	Vanity Base Pullout	111
VCB	Vanity Console Base	110
VCB..B	Vanity Console Base w/Butt Doors	110
VCORBEL	Valance Corbel	144
VDB	Vanity Three Drawer Base	121
VDB-4	Vanity Four Drawer Base	120
VDD	Vanity Doors & Drawer Base	112
Vddb	Vanity Double Drawer Base	113
VddbT	Vanity Double Drawer Base Trimmable	114
VDT	Vanity Drawer Trimmable	123
VFD	Vanity File Drawer	109
Vfdb	Vanity File Drawer Base	108
VMC	Vanity Medicine Cabinet	126
VSB	Vanity Sink Base	114
VSB..B	Vanity Sink Base w/Butt Doors	115
VSB..STS	Vanity Sink Base SuperCabinet™	119
VSB..STSB	Vanity Sink Base SuperCabinet™ w/Butt Doors	119
VSDb	Vanity Sink Drawer Base	119
VSDbT	Vanity Sink Drawer Base Trimmable	120
VTEP	Vanity Tapered End Panel	127
VTMC	Vanity Tri-View Medicine Cabinet	126
VTT	Vanity Tank Topper	123
VWC	Vanity Wall Cabinet	122
VWS	Vanity Wall Sink Cabinet	134
W	Wall Cabinet	38
W..B	Wall Cabinet w/Butt Doors	38
WCUBE	Wine Cube	62
WCUBEDRW	Wine Cube Drawer	62
WD	Wall Drawer Unit	59
WEC	Wall End Cabinet	74
WER	Wall Easy Reach Cabinet	71
WHC	Canopy Wood Hood	63
WMC	Wall Message Center Cabinet	60
WMD	Wall Cabinet w/Mullion Doors	48
WMD..B	Wall Cabinet w/Mullion Butt Doors	48
WN	What-Not Shelf	62
WOL	Wall Open Cabinet	43
WOL2147.5	Wall Open Cabinet w/Apothecary Drawer	59
WPG	Wall Cabinet w/Doors Prepped for Glass	53
WPG..B	Wall Cabinet w/Butt Doors Prepped for Glass	53
WPR	Wall Plate Rack Cabinet	58
WR	Wine Rack Cabinet	58
WSS	Wall System Shelf	153





Style Name	Finish	Standard Style #	Select Style #	APC Style #
<b>Cherry Doors</b>				
<b>Avalon</b> 	Café	59T	99T	79T
	Cocoa Glaze	59J	99J	79J
	Java Glaze	59N	99N	79N
	Rouge	59E	99E	79E
	Saddle	59M	99M	79M
	Umber	59D	99D	79D
	Wheat	59B	99B	79B
<b>Briarcliff II Arch</b> <i>New</i> 	Café	5BR	9BR	7BR
	Cocoa Glaze	5BM	9BM	7BM
	Java Glaze	5BP	9BP	7BP
	Rouge	5BL	9BL	7BL
	Umber	5BK	9BK	7BK
	Saddle	5BN	9BN	7BN
	Wheat	5BJ	9BJ	7BJ
<b>Briarcliff II Square</b> <i>New</i> 	Café	5BH	9BH	7BH
	Cocoa Glaze	5BE	9BE	7BE
	Java Glaze	5BG	9BG	7BG
	Rouge	5BD	9BD	7BD
	Umber	5BC	9BC	7BC
	Saddle	5BF	9BF	7BF
	Wheat	5BB	9BB	7BB
<b>Wentworth</b> 	Café	52T	92T	72T
	Cocoa Glaze	52J	92J	72J
	Java Glaze	52N	92N	72N
	Rouge	52E	92E	72E
	Saddle	52M	92M	72M
	Umber	52D	92D	72D
	Wheat	52B	92B	72B







<b>Oak Doors</b>				
<b>Oakland Arch</b> 	Natural	297	897	697
	Saddle	299	899	699
	Sarsaparilla	294	894	694
	Spice	295	895	695
	Umber	509	909	709
	Wheat	296	896	696
<b>Oakland Square</b> 	Natural	275	875	675
	Saddle	253	853	653
	Sarsaparilla	251	851	651
	Spice	254	854	654
	Umber	508	908	708
	Wheat	255	855	655
<b>Landen</b> 	Natural	270	870	670
	Saddle	271	871	671
	Sarsaparilla	272	872	672
	Spice	273	873	673
	Umber	520	920	720
	Wheat	276	876	676
<b>Westbury Arch</b> 	Natural	267	867	667
	Saddle	269	869	669
	Sarsaparilla	268	868	668
	Spice	265	865	665
	Umber	507	907	707
	Wheat	266	866	666
<b>Westbury Square</b> 	Natural	231	831	631
	Saddle	230	830	630
	Sarsaparilla	234	834	634
	Spice	235	835	635
	Umber	506	906	706
	Wheat	236	836	636







Style Name	Finish	Standard Style #	Select Style #	APC Style #
<b>Hickory Doors</b>				
<b>Pioneer</b> 	Natural	290	890	690
	Saddle	293	893	693
	Wheat	292	892	692

<b>Birch Doors</b>				
<b>Benton</b> 	Antique Paint	246	846	646
	Autumn	240	840	640
	Café	541	941	741
	Fawn	241	841	641
	Rouge	242	842	642
	Saddle	243	843	643
	Sarsaparilla	244	844	644
	Umber	247	847	647
	White Paint	245	845	645
	<b>Saybrooke</b> 	Autumn	225	825
Café		581	981	781
Cocoa Glaze		232	832	632
Fawn		226	826	626
Rouge		228	828	628
Saddle		227	827	627
Sarsaparilla		229	829	629
Umber		501	901	701
<b>Sinclair</b> 	Autumn	220	820	620
	Café	564	964	764
	Cocoa Glaze	233	833	633
	Fawn	221	821	621
	Rouge	223	823	623
	Saddle	222	822	622
	Sarsaparilla	239	839	639
	Umber	500	900	700

<b>Rustic Birch Doors</b>				
<b>Ayden</b> 	Autumn	41F	81F	61F
	Café	41T	81T	61T
	Cocoa Glaze	41J	81J	61J
	Fawn	41G	81G	61G
	Rouge	41E	81E	61E
	Saddle	41M	81M	61M
	Umber	41D	81D	61D
<b>Dryden</b> 	Autumn	47F	87F	67F
	Café	47T	87T	67T
	Cocoa Glaze	47J	87J	67J
	Fawn	47G	87G	67G
	Rouge	47E	87E	67E
	Saddle	47M	87M	67M
<b>Harrison</b> 	Autumn	46F	86F	66F
	Café	46T	86T	66T
	Fawn	46G	86G	66G
	Rouge	46E	86E	66E
	Saddle	46M	86M	66M
	Umber	46D	86D	66D

Style Name	Finish	Standard Style #	Select Style #	APC Style #
<b>Maple Doors</b>				
<b>Avalon</b> 	Autumn	55F	95F	75F
	Café	55T	95T	75T
	Cocoa Glaze	55J	95J	75J
	Fawn	55G	95G	75G
	Java Glaze	55N	95N	75N
	Natural	55C	95C	75C
	Rouge	55E	95E	75E
	Saddle	55M	95M	75M
	Sarsaparilla	55W	95W	75W
	Umber	55D	95D	75D
<b>Briarcliff II Arch</b> <i>New</i> 	Antique Paint	5BA	9BA	7BA
	Autumn	5AS	9AS	7AS
	Café	5AX	9AX	7AX
	Cocoa Glaze	5AU	9AU	7AU
	Fawn	5AT	9AT	7AT
	Java Glaze	5AW	9AW	7AW
	Natural	5AN	9AN	7AN
	Rouge	5AR	9AR	7AR
	Saddle	5AV	9AV	7AV
	Sarsaparilla	5AY	9AY	7AY
	Umber	5AP	9AP	7AP
White Paint	5AZ	9AZ	7AZ	
<b>Briarcliff II Square</b> <i>New</i> 	Antique Paint	5AM	9AM	7AM
	Autumn	5AD	9AD	7AD
	Café	5AJ	9AJ	7AJ
	Cocoa Glaze	5AF	9AF	7AF
	Fawn	5AE	9AE	7AE
	Java Glaze	5AH	9AH	7AH
	Natural	5AA	9AA	7AA
	Rouge	5AC	9AC	7AC
	Saddle	5AG	9AG	7AG
	Sarsaparilla	5AK	9AK	7AK
	Umber	5AB	9AB	7AB
White Paint	5AL	9AL	7AL	
<b>Eastland Arch</b> 	Antique Paint	529	929	729
	Autumn	562	962	762
	Café	522	922	722
	Cocoa Glaze	565	965	765
	Fawn	563	963	763
	Java Glaze	567	967	767
	Natural	561	961	761
	Rouge	560	960	760
	Saddle	566	966	766
	Sarsaparilla	569	969	769
	Umber	504	904	704
	White Paint	528	928	728
<b>Eastland Square</b> 	Antique Paint	527	927	727
	Autumn	552	952	752
	Café	521	921	721
	Cocoa Glaze	555	955	755
	Fawn	553	953	753
	Java Glaze	557	957	757
	Natural	551	951	751
	Rouge	550	950	750
	Saddle	556	956	756
	Sarsaparilla	559	959	759
	Umber	503	903	703
	White Paint	526	926	726

Style Name	Finish	Standard Style #	Select Style #	APC Style #
<b>Maple Doors, <i>continued</i></b>				
<b>Grayson</b> 	Autumn	50F	90F	70F
	Café	50T	90T	70T
	Cocoa Glaze	50J	90J	70J
	Fawn	50G	90G	70G
	Java Glaze	50N	90N	70N
	Natural	50C	90C	70C
	Rouge	50E	90E	70E
	Saddle	50M	90M	70M
	Sarsaparilla	50W	90W	70W
	Umber	50D	90D	70D
<b>Landen</b> 	Antique Paint	588	988	788
	Autumn	572	972	772
	Café	525	925	725
	Cocoa Glaze	575	975	775
	Fawn	573	973	773
	Java Glaze	577	977	777
	Natural	571	971	771
	Rouge	570	970	770
	Saddle	576	976	776
	Sarsaparilla	579	979	779
	Umber	505	905	705
White Paint	587	987	787	
<b>Radford</b> 	Autumn	56F	96F	76F
	Café	56T	96T	76T
	Cocoa Glaze	56J	96J	76J
	Fawn	56G	96G	76G
	Java Glaze	56N	96N	76N
	Natural	56C	96C	76C
	Rouge	56E	96E	76E
	Saddle	56M	96M	76M
	Sarsaparilla	56W	96W	76W
	Umber	56D	96D	76D
	<b>Teagan</b> 	Antique Paint	58Y	98Y
Autumn		58F	98F	78F
Café		58T	98T	78T
Fawn		58G	98G	78G
Natural		58C	98C	78C
Rouge		58E	98E	78E
Saddle		58M	98M	78M
Sarsaparilla		58W	98W	78W
Umber		58D	98D	78D
White Paint		58X	98X	78X
<b>Wentworth</b> 	Antique Paint	51Y	91Y	71Y
	Autumn	51F	91F	71F
	Café	51T	91T	71T
	Cocoa Glaze	51J	91J	71J
	Fawn	51G	91G	71G
	Java Glaze	51N	91N	71N
	Natural	51C	91C	71C
	Rouge	51E	91E	71E
	Saddle	51M	91M	71M
	Sarsaparilla	51W	91W	71W
	Umber	51D	91D	71D
White Paint	51X	91X	71X	
<b>Winstead</b> 	Antique Paint	549	949	749
	Autumn	543	943	743
	Café	594	994	794
	Fawn	544	944	744
	Natural	542	942	742
	Rouge	540	940	740
	Saddle	545	945	745
	Sarsaparilla	547	947	747
	Umber	502	902	702
	White Paint	548	948	748

Style Name	Finish	Standard Style #	Select Style #	APC Style #
<b>PureStyle™ Doors</b>				
<b>Durham</b> 	Toasted Antique	211	811	611
<b>Ellsworth</b> 	White	212	812	612
<b>Overton</b> 	Toasted Antique	250	850	650
<b>Thermofoil Doors</b>				
<b>Augusta</b> 	White	205	805	605
<b>Nantucket</b> 	White	200	800	600
<b>VanWyke</b> 	White	209	809	609

## Common Style Numbers for Finishes



In addition to the style numbers for door styles, there are several common items such as mouldings, panels, valances, fillers, organizers, wood hood units, open shelf units, and other parts that have been changed to a common style number based on finish. Look for the symbol (shown left) used throughout this book indicating Common Items. Please reference these common style numbers in the chart below.

<b>Cherry Café</b>	159
<b>Cherry Cocoa Glaze</b>	175
<b>Cherry Java Glaze</b>	169
<b>Cherry Rouge</b>	174
<b>Cherry Saddle</b>	173
<b>Cherry Umber</b>	156
<b>Cherry Wheat</b>	176
<b>Hickory Natural</b>	190
<b>Hickory Saddle</b>	172
<b>Hickory Wheat</b>	177
<b>Maple Autumn*</b>	183
<b>Maple Café</b>	167
<b>Maple Cocoa Glaze</b>	179
<b>Maple Fawn*</b>	197
<b>Maple Java Glaze</b>	168
<b>Maple Natural</b>	182
<b>Maple Rouge*</b>	180
<b>Maple Saddle*</b>	170
<b>Maple Sarsaparilla</b>	193
<b>Maple Umber</b>	157
<b>Oak Natural</b>	188
<b>Oak Saddle</b>	171
<b>Oak Sarsaparilla</b>	187
<b>Oak Spice</b>	185
<b>Oak Umber</b>	158
<b>Oak Wheat</b>	186
<b>Rustic Autumn****</b>	161
<b>Rustic Café****</b>	154
<b>Rustic Cocoa Glaze****</b>	160
<b>Rustic Fawn****</b>	162
<b>Rustic Saddle****</b>	164
<b>Rustic Rouge****</b>	163
<b>Rustic Umber****</b>	155
<b>Antique**</b>	198
<b>Toasted Antique Glaze***</b>	199
<b>White**</b>	184

\* Use Maple for Birch common items.

\*\* White and Antique common style items will be painted hardwood.

\*\*\* Toasted Antique Glaze common style items will feature a glaze appearance and is only available on selected trim items. All other trim items should be ordered as Antique (#198).

\*\*\*\* Selected Rustic trim items available, use common styles for Maple finishes when not available.

	Miscellaneous Style	010	Miscellaneous items such as Sink Tip-Out Trays, and Cutlery Trays should use Common Style #010.
--	---------------------	-----	---

# DOOR STYLES

## Augusta

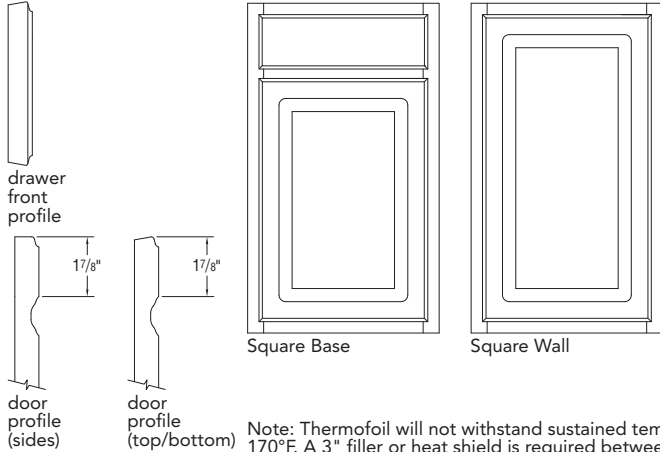

Note: Thermofoil will not withstand sustained temperatures in excess of 170°F. A 3" filler or heat shield is required between any thermofoil surface and any heat source to be in compliance with cabinet warranty.

PRICE COLUMNS		
Thermofoil	Standard Finish	C3

- ▶ 7/16" Overlay
- ▶ Raised Panel Profile
- ▶ 3/4" Thick Door
- ▶ Reverse Bevel Profile, No Hardware Required



## Avalon

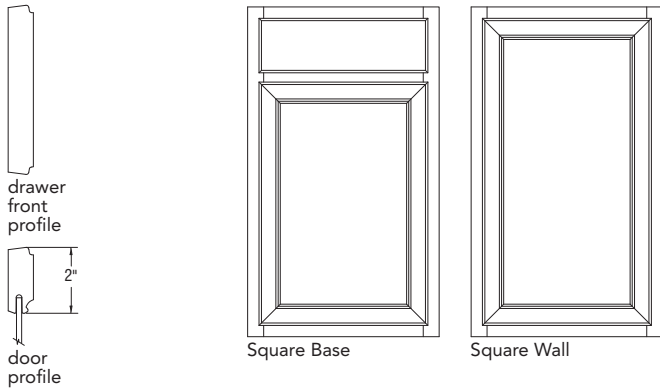

PRICE COLUMNS		
Cherry	Standard Finish	C4
	Glaze	C6
Maple	Standard Finish	C3
	Glaze	C5

- ▶ 7/16" Overlay
- ▶ Flat Veneer Center Panel
- ▶ 3/4" Thick Solid Door Rail
- ▶ Miter Construction
- ▶ Reverse Bevel Profile, No Hardware Required



## Ayden

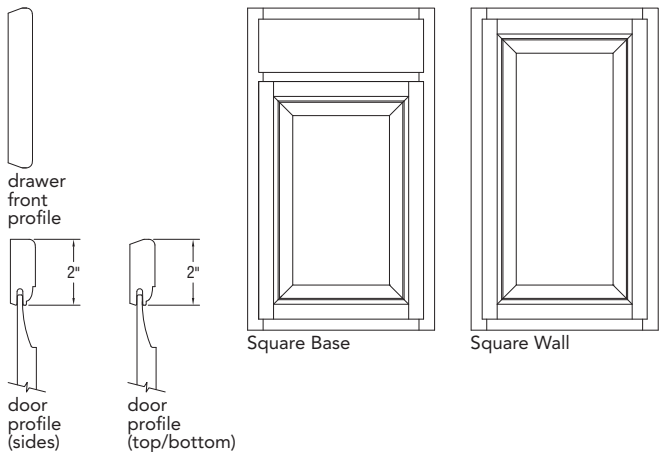

PRICE COLUMNS		
Rustic Birch	Standard Finish	P3
	Glaze	P5

- ▶ 7/16" Overlay
- ▶ Raised Solid Center Panel
- ▶ 3/4" Thick Solid Door Rail
- ▶ Hardware Recommended
- ▶ Rustic Characteristics on Door and Drawer Fronts only
- ▶ Selected Rustic Trim Items Available. Use Common Styles for Maple Finishes When Not Available. See page 166.



- ▶ Butt Door Cabinets Available

# DOOR STYLES

## Benton

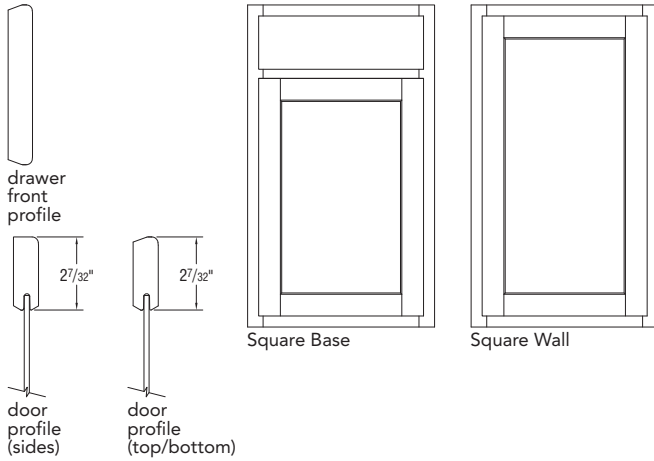

PRICE COLUMNS		
Birch	Standard Finish	P1
	Paint	P3

- ▶ 7/16" Overlay
- ▶ Flat Veneer Center Panel
- ▶ 3/4" Thick Solid Door Rail
- ▶ Birch Styles Use Maple Accessories
- ▶ Reverse Bevel Profile, No Hardware Required



- ▶ Butt Door Cabinets Available

## Briarcliff II *New*

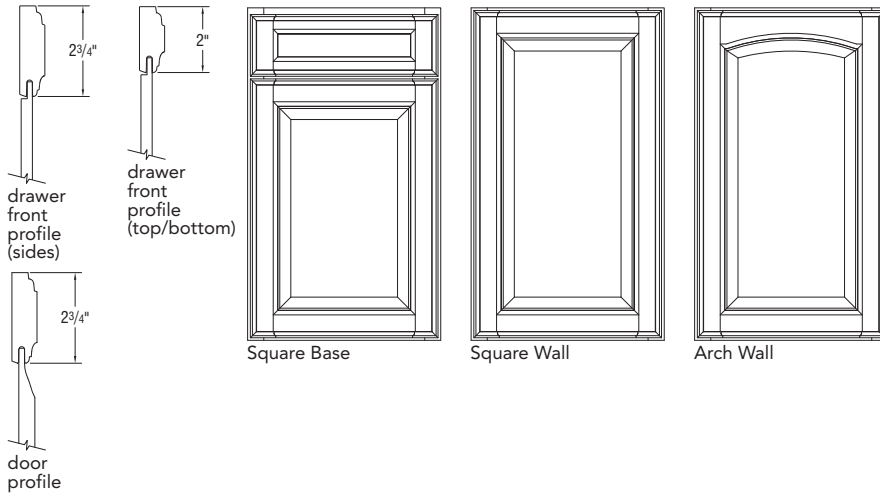

PRICE COLUMNS		
Cherry	Standard Finish	P8
	Glaze	P9
Maple	Standard Finish	P6
	Paint	P8
	Glaze	P8

- ▶ Full Overlay
- ▶ Raised Veneer Center Panel
- ▶ 3/4" Thick Solid Door Rail
- ▶ 5-Piece Drawer Front with Recessed Center Panel (Drawer Fronts 11 5/8" and Higher have a Raised Veneer Center Panel with Vertical Grain)
- ▶ Hardware Recommended
- ▶ Square Doors on Base Cabinets



- ▶ Butt Door Cabinets Available

## Dryden

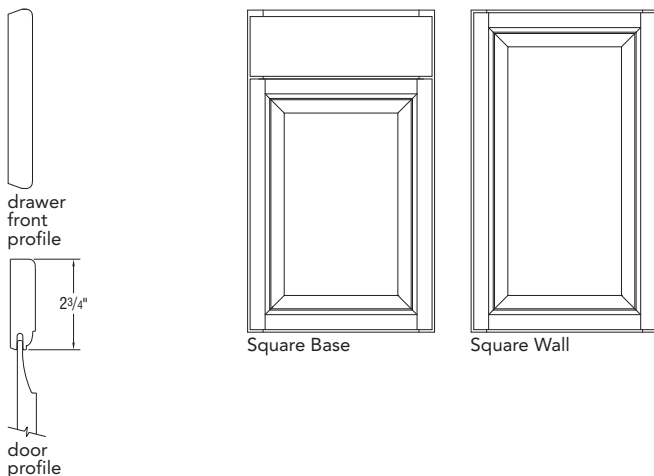

PRICE COLUMNS		
Rustic Birch	Standard Finish	P5
	Glaze	P8

- ▶ Full Overlay
- ▶ Raised Solid Center Panel
- ▶ 3/4" Thick Solid Door Rail
- ▶ Hardware Recommended
- ▶ Rustic Characteristics on Door and Drawer Fronts only
- ▶ Selected Rustic Trim Items Available. Use Common Styles for Maple Finishes When Not Available. See page 166.



- ▶ Butt Door Cabinets Available

# DOOR STYLES

## Durham

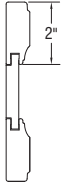

drawer front profile



door profile

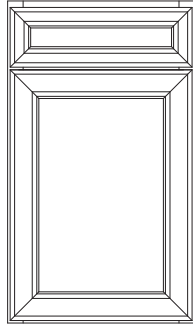

Square Base

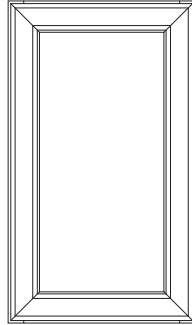

Square Wall

PRICE COLUMNS		
PureStyle™	Standard Finish	P6

- ▶ Full Overlay
- ▶ 3/4" Thick Door Rail
- ▶ Miter Construction
- ▶ Flat Laminate Center Panel
- ▶ 5-Piece Miter Drawer Front
- ▶ Toasted Antique Glaze Available on Selected Trim Items. See page 166.
- ▶ Hardware Recommended



- ▶ Butt Door Cabinets Available

## Eastland



drawer front profile



door profile

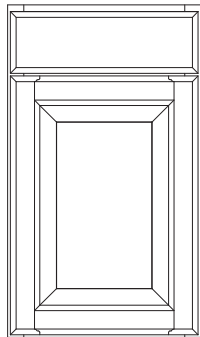

Square Base

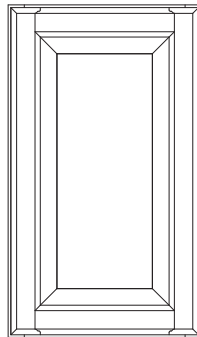

Square Wall

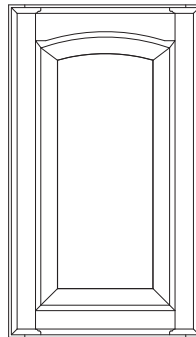

Arch Wall

PRICE COLUMNS		
Maple	Standard Finish	P7
	Paint	P9
	Glaze	P9

- ▶ Full Overlay
- ▶ Raised Solid Center Panel
- ▶ 3/4" Thick Solid Door Rail
- ▶ Square Doors on Base Cabinets
- ▶ Hardware Recommended



- ▶ Butt Door Cabinets Available

## Ellsworth



drawer front profile



door profile

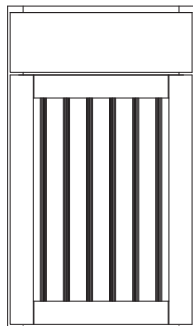

Square Base

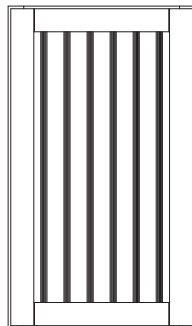

Square Wall

PRICE COLUMNS		
PureStyle™	Standard Finish	P4

- ▶ Full Overlay
- ▶ 3/4" Thick Door Rail
- ▶ Beaded Laminate Center Panel
- ▶ Hardware Recommended



- ▶ Butt Door Cabinets Available

# DOOR STYLES

## Grayson

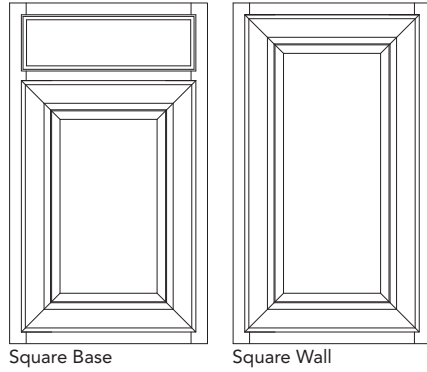

PRICE COLUMNS		
Maple	Standard Finish	P5
	Glaze	P8

- ▶ 7/16" Overlay
- ▶ Raised Veneer Center Panel
- ▶ 3/4" Thick Solid Door Rail
- ▶ Miter Construction
- ▶ Hardware Recommended



- ▶ Butt Door Cabinets Available

## Harrison

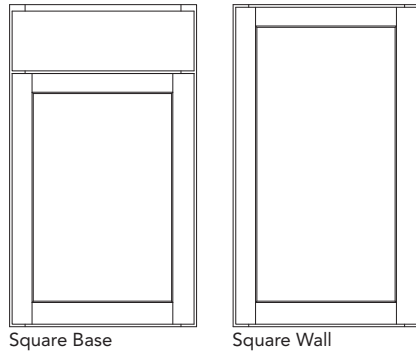

PRICE COLUMNS		
Rustic Birch	Standard Finish	P4

- ▶ Full Overlay
- ▶ Reversed Raised Solid Center Panel
- ▶ 3/4" Thick Solid Door Rail
- ▶ Hardware Recommended
- ▶ Rustic Characteristics on Door and Drawer Fronts only
- ▶ Selected Rustic Trim Items Available. Use Common Styles for Maple Finishes When Not Available. See page 166.



- ▶ Butt Door Cabinets Available

## Landen

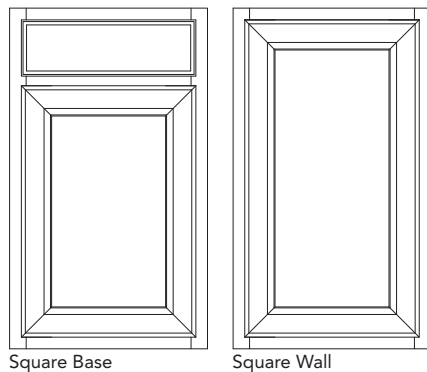
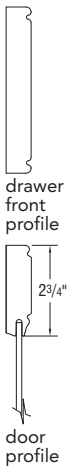

PRICE COLUMNS		
Maple	Standard Finish	P2
	Paint	P4
	Glaze	P5
Oak	Standard Finish	P1

- ▶ 7/16" Overlay
- ▶ Flat Veneer Center Panel
- ▶ 3/4" Thick Solid Door Rail
- ▶ Miter Construction
- ▶ Hardware Recommended



- ▶ Butt Door Cabinets Available

# DOOR STYLES

## Nantucket

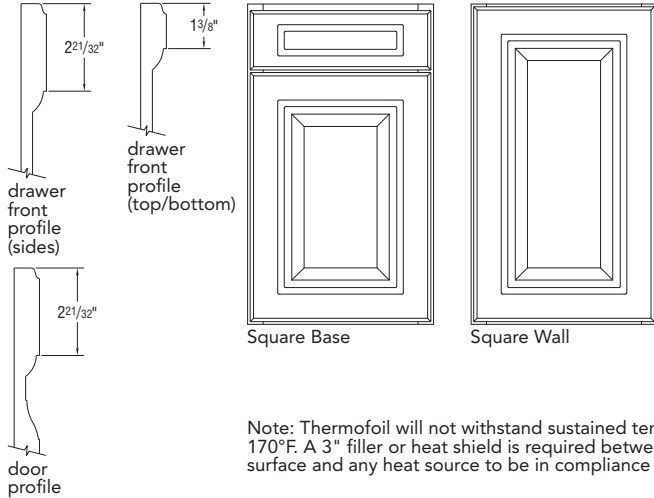

PRICE COLUMNS		
Thermofoil	Standard Finish	P5

- ▶ Full Overlay
- ▶ Raised Panel Profile
- ▶ 3/4" Thick Door
- ▶ Satin Thermofoil
- ▶ Recessed Drawer Front Center Panel (Drawer Fronts 11 5/8" and Higher have a Raised Center Panel)
- ▶ Hardware Recommended



- ▶ Butt Door Cabinets Available

## Oakland

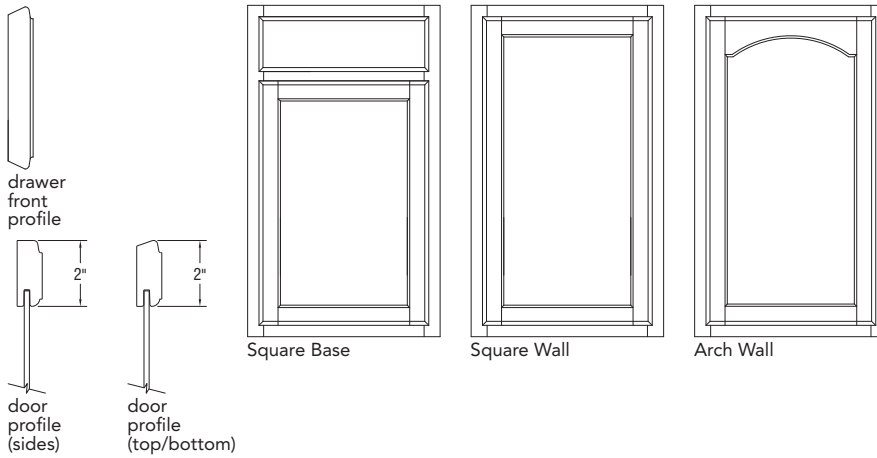

PRICE COLUMNS		
Oak	Standard Finish	C1

- ▶ 7/16" Overlay
- ▶ Flat Veneer Center Panel
- ▶ 3/4" Thick Solid Door Rail
- ▶ Square Doors on Base Cabinets
- ▶ Reverse Bevel Profile, No Hardware Required



## Overton

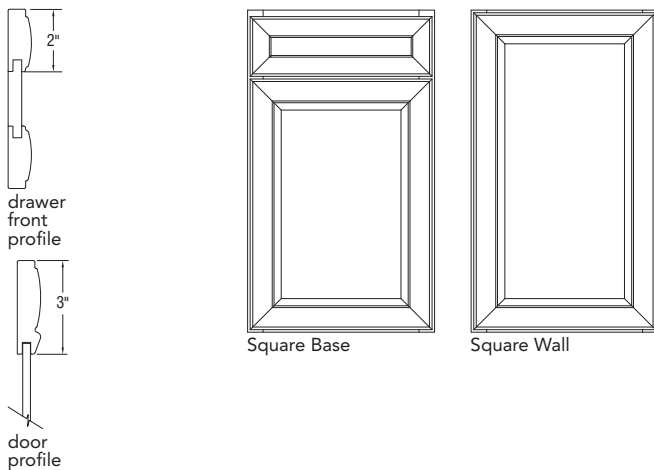

PRICE COLUMNS		
PureStyle™	Standard Finish	P6

- ▶ Full Overlay
- ▶ 3/4" Thick Door Rail
- ▶ Miter Construction
- ▶ Flat Laminate Center Panel
- ▶ 5-Piece Miter Drawer Front
- ▶ Toasted Antique Glaze Only Available on Selected Trim Items. See page 166.
- ▶ Hardware Recommended



- ▶ Butt Door Cabinets Available

# DOOR STYLES

## Pioneer

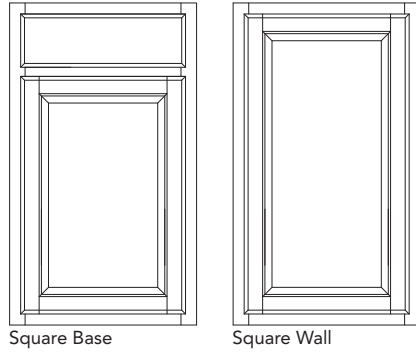
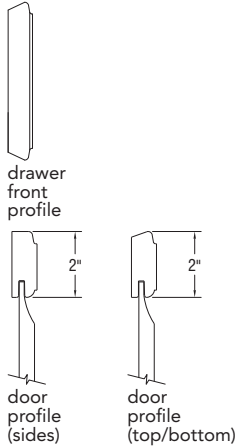

PRICE COLUMNS		
Hickory	Standard Finish	C3

- ▶ 7/16" Overlay
- ▶ Raised Veneer Center Panel
- ▶ 3/4" Thick Solid Door Rail
- ▶ Reverse Bevel Profile, No Hardware Required



## Radford

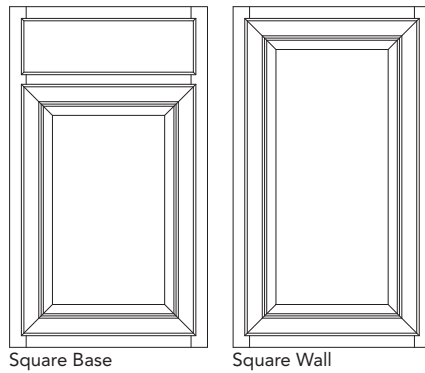
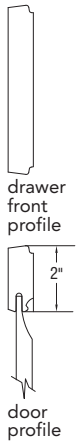

PRICE COLUMNS		
Maple	Standard Finish	P4
	Glaze	P7

- ▶ 7/16" Overlay
- ▶ Raised Veneer Center Panel
- ▶ 3/4" Thick Solid Door Rail
- ▶ Miter Construction
- ▶ Reverse Bevel Profile, No Hardware Required



- ▶ Butt Door Cabinets Available

## Saybrooke

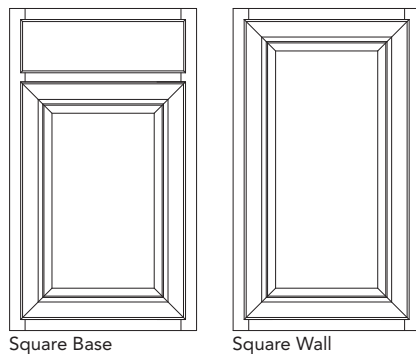

PRICE COLUMNS		
Birch	Standard Finish	P2
	Glaze	P5

- ▶ 7/16" Overlay
- ▶ Raised Veneer Center Panel
- ▶ 3/4" Thick Solid Door Rail
- ▶ Miter Construction
- ▶ Birch Styles Use Maple Accessories
- ▶ Hardware Recommended



- ▶ Butt Door Cabinets Available

# DOOR STYLES

## Sinclair

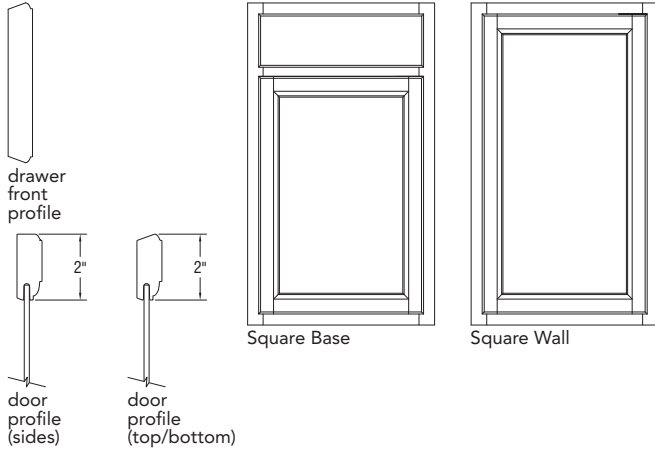

PRICE COLUMNS		
Birch	Standard Finish	C2
	Glaze	C3

- ▶ 7/16" Overlay
- ▶ Flat Veneer Center Panel
- ▶ 3/4" Thick Solid Door Rail
- ▶ Birch Styles Use Maple Accessories
- ▶ Reverse Bevel Profile, No Hardware Required



## Teagan

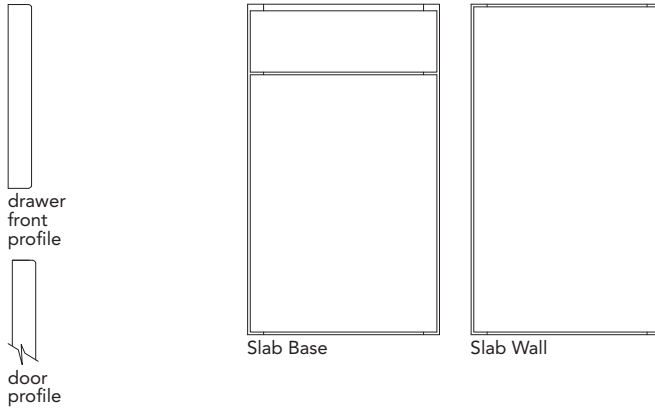

PRICE COLUMNS		
Maple	Standard Finish	P5
	Paint	P8

- ▶ Full Overlay
- ▶ Veneer Slab Door
- ▶ Veneer Face and Back with Furniture Board Core
- ▶ 3mm Wood Edging on all Edges
- ▶ Hardware Recommended



- ▶ Butt Door Cabinets Available

## VanWyke

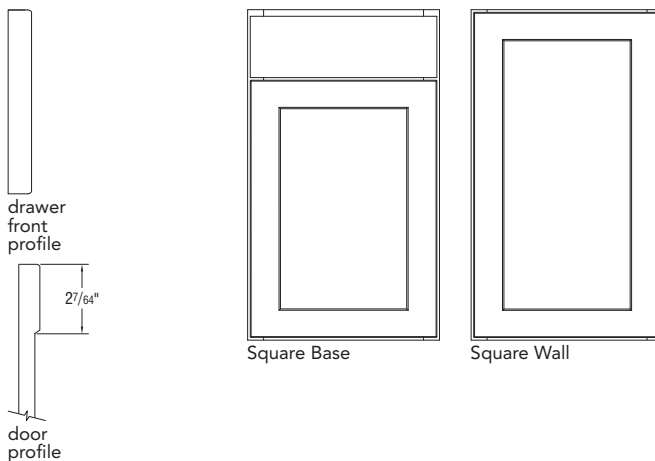

PRICE COLUMNS		
Thermofoil	Standard Finish	C3

- ▶ Full Overlay
- ▶ Recessed Panel Profile
- ▶ 3/4" Thick Door
- ▶ 6-way Adjustable Hinges
- ▶ Hardware Recommended



# DOOR STYLES

## Wentworth

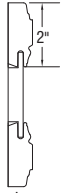

drawer front profile

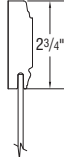

door profile

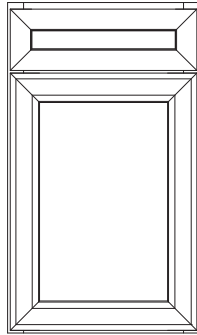

Square Base

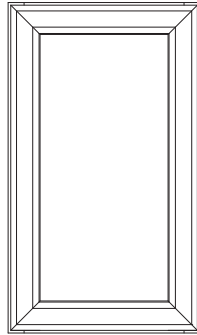

Square Wall

PRICE COLUMNS		
Cherry	Standard Finish	P7
	Glaze	P9
Maple	Standard Finish	P5
	Glaze	P8
	Paint	P8

- ▶ Full Overlay
- ▶ Flat Veneer Center Panel
- ▶ 3/4" Thick Solid Door Rail
- ▶ Miter Construction
- ▶ 5-Piece Miter Drawer Front
- ▶ Hardware Recommended



- ▶ Butt Door Cabinets Available

## Westbury



drawer front profile

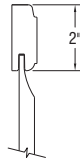

door profile (sides)

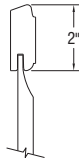

door profile (top/bottom)

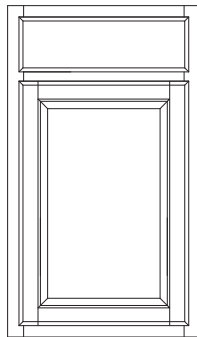

Square Base

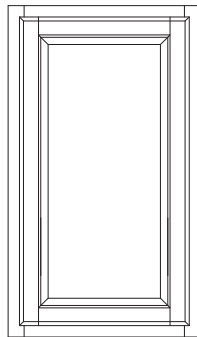

Square Wall

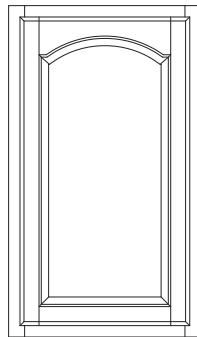

Arch Wall

PRICE COLUMNS		
Oak	Standard Finish	C3

- ▶ 7/16" Overlay
- ▶ Raised Veneer Center Panel
- ▶ 3/4" Thick Solid Door Rail
- ▶ Square Doors on Base Cabinets
- ▶ Reverse Bevel Profile, No Hardware Required



# DOOR STYLES

## Winstead



drawer front profile



door profile

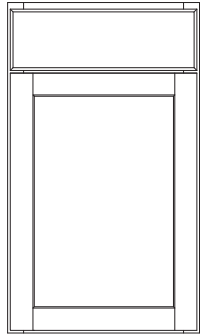

Square Base

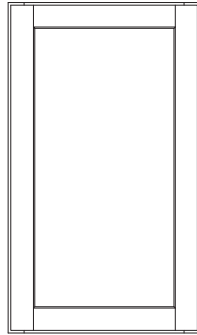

Square Wall

PRICE COLUMNS		
Maple	Standard Finish	P4
	Paint	P6

- ▶ Full Overlay
- ▶ Flat Veneer Center Panel
- ▶ 3/4" Thick Solid Door Rail
- ▶ Hardware Recommended



- ▶ Butt Door Cabinets Available

## Overlay Information

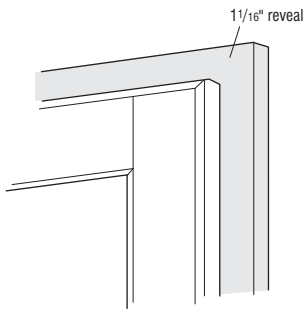

### Partial Overlay 7/16"

- ▶ Partial overlay doors reveal 1 1/16" of the cabinet face frame

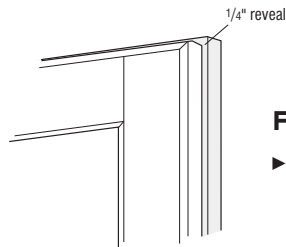

### Full Overlay

- ▶ Full overlay reveal 1/4" of the cabinet face frame

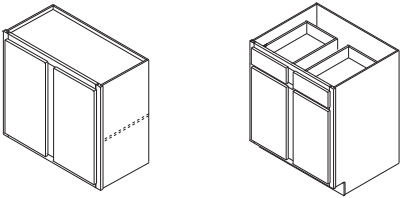
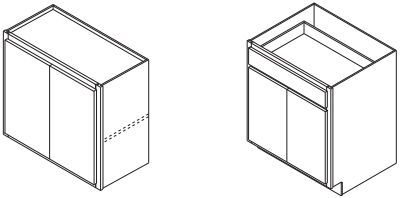
FEATURES	
Butt Door Availability	
Butt Doors not available Center Mullion Standard on Double Door Cabinets 27" - 36" Wide	Choice of Butt Doors or Center Mullion on Double Door Cabinets 27" - 36" Wide  Butt Door Cabinets are Indicated by "B" on the end of the product code (i.e. B30B, W3030B)  Base Cabinets with Butt Doors Have a Single Drawer
Cabinet Configurations	
Cabinets with Center Mullions  	Cabinets with Butt Doors  
DOOR STYLE AVAILABILITY	
Cherry	
Avalon	Briarcliff II Wentworth
Maple	
Avalon	Briarcliff II Eastland Grayson Landen Radford Teagan Wentworth Winstead
Oak	
Oakland Westbury	Landen
Hickory	
Pioneer	
Birch	
Sinclair	Benton Saybrooke
Rustic Birch	
	Ayden Dryden Harrison
PureStyle™	
	Durham Ellsworth Overton
Thermofoil	
Augusta VanWyke	Nantucket



	STANDARD	SELECT	APC
<b>CABINETS</b>	INTERIOR COMPONENTS	Aristex® Natural Maple Laminate (White Styles feature Aristex® White Laminate)	Aristex® Natural Maple Laminate (White Styles feature Aristex® White Laminate on all interior components except cabinet drawers)
	SIDES	3/8" Thick Furniture Board with Matching Laminate Exterior	3/8" Thick Plywood, Finished Veneer Exterior
	BACK	3/8" Thick Furniture Board	3/8" Thick Plywood
	TOP (wall)	1/2" Thick Furniture Board	1/2" Thick Plywood
	BOTTOM (wall)	1/2" Thick Furniture Board	1/2" Thick Plywood
	BOTTOM (base)	3/8" Thick Furniture Board	3/8" Thick Plywood
	CORNERS (base)	Four Furniture Board Braces	Two Plywood Stretcher Rails
	FACE FRAME	3/4" x 1 1/2" Solid Wood	
	SHELVES (wall and tall)	Adjustable 3/4" Thick Furniture Board (15 lbs. maximum weight per square foot)	Adjustable 3/4" Thick Plywood (15 lbs. maximum weight per square foot)
	SHELVES (base)	Fixed 1/2" Thick Half-Depth Furniture Board Adjustable 3/4" Thick Full-Depth Furniture Board on Open & Full Height Base Cabinets	Fixed 1/2" Thick Half-Depth Plywood Adjustable 3/4" Thick Full-Depth Plywood on Open & Full Height Base Cabinets
	TOEKICK	3/8" Thick x 4" High Furniture Board, Recessed 3 3/8", Unfinished (Requires cover: TOEKICK/TOEKICK8)	3/8" Thick x 4" High Plywood, Recessed 3 3/8", Unfinished (Requires cover: TOEKICK/TOEKICK8)
	CENTER MULLION & BUTT DOOR CABINETS	Butt Doors are standard on 24" double door cabinets. Center Mullion is standard on double door cabinets 27" - 36" wide.	
HINGES	6-Way Adjustable, Fully Concealed, Steel Hinges		
<b>DRAWERS</b>	DRAWER BOX SIDES, BACK, & FRONT	1/2" Thick Furniture Board	3/4"* Thick All Wood with Clear Topcoat <i>*1/4" prior to final processing. Actual final dimensions will vary.</i>
	DRAWER BOTTOM	3/8" Thick Furniture Board, Stapled into Sides, Front, & Back	1/4" Thick Plywood, Fully Captured
	DRAWER GUIDES	Side-Mount, Epoxy-Coated, Double Rails, Captured on Two Sides, Built-In Drawer Stop	Undermount, Epoxy-Coated, Double Rails, Captured on Two Sides
	DRAWER BOX JOINT	Stapled, Butt Joint	Dovetail Joint
	DRAWER BOX DEPTH	Base Cabinets – 20" Vanities (21" deep) – 20" Vanities (18" deep) – 15 1/2"	Base Cabinets – 21" Vanities (21" deep) – 18" Vanities (18" deep) - not available
	FULL EXTENSION Smart Stop™ UPGRADE	N/A	Concealed Full Extension Drawer Guides with Smart Stop™ for Select and All Plywood Construction Options
	CAPACITY	Rated at 75 lbs. capacity per drawer for all guides	



	STANDARD	SELECT	APC
--	----------	--------	-----

CABINETS	INTERIOR COMPONENTS	Aristex® Natural Maple Laminate (White Styles feature Aristex® White Laminate)	Aristex® Natural Maple Laminate (White Styles feature Aristex® White Laminate on all interior components except cabinet drawers)	
	SIDES	3/8" Thick Furniture Board with Matching Laminate Exterior		3/8" Thick Plywood, Finished Veneer Exterior
	BACK	3/8" Thick Furniture Board		3/8" Thick Plywood
	TOP (wall)	1/2" Thick Furniture Board		1/2" Thick Plywood
	BOTTOM (wall)	1/2" Thick Furniture Board		1/2" Thick Plywood
	BOTTOM (base)	3/8" Thick Furniture Board		3/8" Thick Plywood
	CORNERS (base)	Four Furniture Board Braces		Two Plywood Stretcher Rails
	FACE FRAME	3/4" x 1 1/2" Solid Wood		
	SHELVES (wall and tall)	Adjustable 3/4" Thick Furniture Board (15 lbs. maximum weight per square foot)		Adjustable 3/4" Thick Plywood (15 lbs. maximum weight per square foot)
	SHELVES (base)	Fixed 1/2" Thick Half-Depth Furniture Board Adjustable 3/4" Thick Full-Depth Furniture Board on Open & Full Height Base Cabinets		Fixed 1/2" Thick Half-Depth Plywood Adjustable 3/4" Thick Full-Depth Plywood on Open & Full Height Base Cabinets
	TOEKICK	3/8" Thick x 4" High Furniture Board, Recessed 3 3/8", Unfinished (Requires cover: TOEKICK/TOEKICK8)		3/8" Thick x 4" High Plywood, Recessed 3 3/8", Unfinished (Requires cover: TOEKICK/TOEKICK8)
	CENTER MULLION & BUTT DOOR CABINETS	Butt Doors are standard on 24" double door cabinets. Choice of Butt Doors or Center Mullion available on double door cabinets 27" - 36" wide.		
	HINGES	6-Way Adjustable, Fully Concealed, Steel Hinges		
DRAWERS	DRAWER BOX SIDES, BACK, & FRONT	1/2" Thick Furniture Board	3/4"* Thick All Wood with Clear Topcoat <i>*3/4" prior to final processing. Actual final dimensions will vary.</i>	
	DRAWER BOTTOM	3/8" Thick Furniture Board, Stapled into Sides, Front, & Back	1/4" Thick Plywood, Fully Captured	
	DRAWER GUIDES	Side-Mount, Epoxy-Coated, Double Rails, Captured on Two Sides, Built-In Drawer Stop	Undermount, Epoxy-Coated, Double Rails, Captured on Two Sides	
	DRAWER BOX JOINT	Stapled, Butt Joint	Dovetail Joint	
	DRAWER BOX DEPTH	Base Cabinets – 20" Vanities (21" deep) – 20" Vanities (18" deep) – 15 1/2"	Base Cabinets – 21" Vanities (21" deep) – 18" Vanities (18" deep) - not available	
	FULL EXTENSION Smart Stop™ UPGRADE	N/A	Concealed Full Extension Drawer Guides with Smart Stop™ for Select and All Plywood Construction Options	
	CAPACITY	Rated at 75 lbs. capacity per drawer for all guides		

	STANDARD FINISH										LAMINATE		GLAZE		PAINT	
	Autumn	Café	Fawn	Natural	Rouge	Saddle	Sarasparilla	Spice	Umber	Wheat†	Toasted Antique	White*	Cocoa Glaze	Java Glaze	Antique Paint	White Paint*
<b>CHERRY</b>																
Avalon		✓			✓	✓			✓	✓			✓	✓		
Briarcliff II	<i>New</i>	✓			✓	✓			✓	✓			✓	✓		
Wentworth		✓			✓	✓			✓	✓			✓	✓		
<b>MAPLE</b>																
Avalon	✓	✓	✓	✓	✓	✓	✓		✓				✓	✓		
Briarcliff II	<i>New</i>	✓	✓	✓	✓	✓	✓		✓				✓	✓	✓	✓
Eastland	✓	✓	✓	✓	✓	✓	✓		✓				✓	✓	✓	✓
Grayson	✓	✓	✓	✓	✓	✓	✓		✓				✓	✓		
Landen	✓	✓	✓	✓	✓	✓	✓		✓				✓	✓	✓	✓
Radford	✓	✓	✓	✓	✓	✓	✓		✓				✓	✓		
Teagan	✓	✓	✓	✓	✓	✓	✓		✓						✓	✓
Wentworth	✓	✓	✓	✓	✓	✓	✓		✓				✓	✓	✓	✓
Winstead	✓	✓	✓	✓	✓	✓	✓		✓						✓	✓
<b>OAK</b>																
Landen				✓		✓	✓	✓	✓	✓						
Oakland				✓		✓	✓	✓	✓	✓						
Westbury				✓		✓	✓	✓	✓	✓						
<b>HICKORY</b>																
Pioneer				✓		✓				✓						
<b>BIRCH</b>																
Benton	✓	✓	✓		✓	✓	✓		✓						✓	✓
Saybrooke	✓	✓	✓		✓	✓	✓		✓				✓			
Sinclair	✓	✓	✓		✓	✓	✓		✓				✓			
<b>RUSTIC BIRCH</b>																
Ayden	✓	✓	✓		✓	✓			✓				✓			
Dryden	✓	✓	✓		✓	✓			✓				✓			
Harrison	✓	✓	✓		✓	✓			✓							
<b>PURESTYLE™</b>																
Durham											✓					
Ellsworth												✓				
Overton											✓					
<b>THERMOFOIL</b>																
Augusta												✓				
Nantucket												✓				
VanWyke												✓				

† The laminate used on Cherry Wheat cabinets is matched to aged Cherry Wheat.

\* White styles will have all white interior components.

## Finishing Process

Aristokraft offers a variety of cabinet construction and finish options in order to allow for maximum design flexibility. Below are details about wood characteristics to assist you in deciding on a wood type and finish.

The Aristokraft finishing process starts with top quality lumber that is sanded down to reach those difficult areas before the doors are assembled. After assembly, each door is inspected before a toner is applied with a spray. After applying toner to each door, drawer front, and face frame, a layer of stain is added using a spray finish which is then hand rubbed into the wood for maximum penetration and long-lasting beauty. A UV sealer is then applied during the finishing process to fill the grain. Finally, a UV topcoat is applied onto the door, providing a protective layer and beautiful, lasting finish. A final inspection is given at the end of the process to ensure each door is ready for cabinet assembly.

The finish you select for your door style is just as important as the wood type. Each piece of wood will react differently to the finish material used, resulting in a slight variation in shade within and between cabinets. When natural, light, or tinted finishes are applied, the natural grain characteristics are apparent. For easy care and lasting beauty, Aristokraft covers interior surfaces of cabinet walls, backs, and shelves with Aristex® surface, a urethane-coated laminate.

## How to Use Door Style Numbers

Each door style described in this catalog is available in three construction methods - Standard, Select, and APC. Depending on what finish color is being specified, each one will have its own unique style number.

- Examples:**
- ▶ Westbury Square Wheat is #236
  - ▶ Westbury Square Wheat Select is #836
  - ▶ Westbury Square Wheat APC is #636

## How to Order Upgrade Features

Refer to the chart in the upper left corner of each page for the upgrade charges. To calculate the price of Select and APC cabinets, add the upcharge amount per drawer quantity to the standard price. For cabinets without drawers, refer to the APC cabinet charge noted. If there is no chart, upgrades are not applicable on the SKUs within that page. For cabinets not affected by a construction upgrade, pricing is not affected, but most cabinets are still available to order in the Select and APC style numbers.

UPGRADES (add to list price)	
APC Cabinet Upgrade	58

EXAMPLE		
W3030 in Oakland		
Standard	Select	APC
256	256	256
		+ 58
		<b>314</b>

Select Construction upgrade is not applicable on cabinets without drawers.

UPGRADES (add to list price)			
Drawer Qty.	Select	APC*	FX/Smart Stop™ Drawer Guides†
1	74	182	38
2	148	256	76
3	222	330	114
4	296	404	152
6	444	552	228
8	592	700	304

\*Price includes \$108 per cabinet upcharge  
†Available only with Select and APC

EXAMPLE		
B30 in Oakland		
Standard	Select	APC
316	316	316
	+ 148	+ 256
	<b>464</b>	<b>572</b>

Full Extension with Smart Stop™ is available with Select and APC cabinets, and is noted in this book with "FX" by the product code (i.e. B15<sup>FX</sup>). Refer to the chart in the upper left corner of each page for the FX/Smart Stop™ upgrade charge. To calculate the list price, add the upcharge amount per drawer quantity to the Select or APC price. If there is no chart, upgrades are not applicable on the SKUs within that page.

UPGRADES (add to list price)			
Drawer Qty.	Select	APC*	FX/Smart Stop™ Drawer Guides†
1	74	182	38
2	148	256	76
3	222	330	114
4	296	404	152
6	444	552	228
8	592	700	304

\*Price includes \$108 per cabinet upcharge  
†Available only with Select and APC

EXAMPLE		
B30FX in Oakland		
Standard	Select	APC
N/A	316	316
	+ 148	+ 256
	+ 76	+ 76
	<b>540</b>	<b>648</b>

## How to Order Cabinet Front-Onlys

Cabinet Front-Onlys (FO) include the following parts (where applicable): frame, hinged door(s), drawer front(s), and non-matching toeboard. Parts not included: cabinet floor and cabinet accessories (door racks, wastebaskets, sink tip-out trays, pull-outs, etc). Front-Onlys are available in Standard door style numbers and are not trimmable. Front-Only list price is 70% of the cabinet list price. Not available to order through 20/20, contact customer service.

**Examples:**

Oakland W3030:	Oakland FOW3030:
Standard Construction \$256	Standard Construction \$256 X 70% = \$179

Not available on the following types of cabinets (contact customer service for additional availability questions):

- ▶ Sink Base Cabinets or Sink Fronts
- ▶ Base-height Vanities that share a frame configuration with a standard Base Cabinet
- ▶ Base Roll-Tray Cabinets 15" - 24" wide or 39" - 48" wide
- ▶ 12" deep Base Cabinets (use SKU for 24" deep)
- ▶ 15" or 24" deep Wall Cabinets (use SKU for 12" deep)
- ▶ 18" deep Vanities (use SKU for 21" deep)
- ▶ 12" deep Utilities (use SKU for 24" deep)
- ▶ Corner Cabinets with angled frames (SCER, SCR, BRER, BLS, and BECF)

No matter which wood type you choose for your new kitchen or bath cabinetry, please keep in mind that no two pieces of wood are exactly the same. Stains are likely to exaggerate the difference between open and closed grains and other markings in wood. Grain variation and color change should be expected. As hardwood ages, it will darken when exposed to different types of light. Color differences or changes in wood can also be caused by exposure to harsh chemicals, extreme heat, or other contributing external conditions. Additionally, wood species exhibit other defining characteristics, such as mineral deposits/streaks, knots, sap runs, pin holes, and wormholes. These markings make the wood unique and contribute to its enduring beauty.



### Cherry

- ▶ Top-of-the-line hardwood with a rich, natural reddish-brown tone
- ▶ Uniform tight grain allows finishes to be applied with ease
- ▶ Characteristics include mineral streaks, pin knots, and curly graining
- ▶ Darkens with age and exposure to light
- ▶ Smooth wood grain pattern with random markings

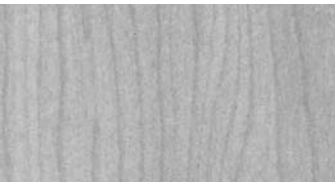

### Maple

- ▶ Strong, resilient wood with a uniform tight grain and smooth, even appearance
- ▶ Mineral streaks are common and will appear darker with stain
- ▶ Subtle wood grain markings include fine lines and wavy or curly graining
- ▶ Small, black "bird's eye" dots



### Oak

- ▶ Very strong wood with distinct grain patterns
- ▶ Grain variations create a color gradation when stain is applied
- ▶ Grain patterns include fine lines, pin stripes, leafy grains, and watery figures



### Birch

- ▶ Even-textured, fine-grained wood with a curly or wavy pattern
- ▶ Strong with a high resistance to abrasion
- ▶ Smooth, dense surface texture
- ▶ Tight wood grain appearance



### Hickory

- ▶ Smooth, extremely strong, close-grained wood with a flowing grain pattern
- ▶ Characteristics include pecks, mineral streaks, and burls
- ▶ Even texture welcomes a full range of finishes with ease
- ▶ Drastic changes from light to dark in wood grain
- ▶ Dramatic, rugged appearance

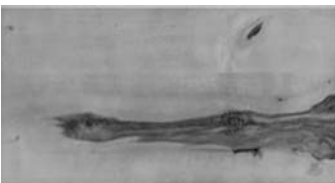

### Rustic Characteristics

#### Solid Wood Doors and Drawer Fronts:

- ▶ Sound Closed Knot (stable / not moveable) – Acceptable up to 3" in diameter
- ▶ Sound Knot with Cracks – Acceptable up to 2" in diameter, with open portion not to exceed 3/4" in diameter or length. May be completely visible through to back side of door.
- ▶ Open Knot – Acceptable up to 3/4" in diameter or length of open portion of knot. May be completely visible through to back side of door. (Note: Holes created by open knots are acceptable and desirable for this rustic look.)
- ▶ Unsound Knot (loose / moveable) – Unacceptable
- ▶ Knot Cluster (cluster of tight, sound knots) – Acceptable in all sizes and quantities
- ▶ Season Checks (crack) – Acceptable, as long as light does not pass through opening
- ▶ Worm / Pin Holes – Acceptable if present on less than 50% of door and less than 1/4" in diameter. May be completely visible through to back side of door.
- ▶ Worm Tracks – Acceptable if present on less than 50% of door and less than 1/8" in diameter and 8" in length
- ▶ Mineral Stains / Streaks / Deposits – Acceptable if present on less than 50% of door. May be black or brown in color.
- ▶ Natural Wood Figuring – Acceptable to have bird's eye, curly graining, burl graining or tiger striping if present on less than 50% of door

#### Veneer Panels / Mouldings / Other Trim Items:

- ▶ Will have few to no sound closed knots, sound knots with cracks, open knots, or knot clusters
- ▶ May have some visible worm / pin holes, mineral stains / streaks / deposits, or natural wood figuring

## Characteristics of Paint

Paint may develop hairline cracks in the finish, most notable around the joints. This is a result of natural expansion and contraction of the genuine hardwoods used in the manufacturing of this product. Hairline cracks are not considered a defect in the cabinetry or finish.

## Characteristics of Laminates

### Thermofoil

- ▶ Doors & drawer fronts are shaped MDF core covered with a seamless vinyl laminate on face & edges, and a melamine laminate on back
- ▶ Vinyl laminate is applied to MDF with an adhesive using heat & pressure
- ▶ Creates a product with excellent wear and heat resistance properties

### PureStyle™

- ▶ Durable, laminate-based material that provides superior abrasion resistance
- ▶ Meets/exceeds all KCMA performance standards
- ▶ Wrapped door rails and panels
- ▶ Clear, pre-impregnated top coat for superior durability (glazed styles have an oven-cured top coat)
- ▶ Lineals and core panel material are made of MDF to ensure a consistent and stable product
- ▶ PureStyle™ doors can be distinguished from painted cabinets by their picture-perfect distribution of satin, smooth color

These doors offer the durability of a laminate and the beauty of paint, while bringing peace of mind to those who care about creating a better environment - both inside and outside of their homes. Molded decorative door profile with a durable, yet attractive finish offers care-free maintenance. In addition to a uniform appearance, cabinets will have:

- ▶ A sleek surface
- ▶ A design that replicates a painted finish with optimum durability
- ▶ A fresh, contemporary feel that is also at home in a more traditional setting

*PureStyle™ trim items will feature a matching painted finish, except where noted in product specifications.*

## Humidification

Cabinet components are typically manufactured at a target range of 40%–50% relative humidity. This works well because even unhumidified homes stay between 20% and 70% in normal years with typical cooking and washing activities.

In extremely cold, dry winters some doors can be exposed to conditions where relative humidity is below 20% for weeks at a time, causing shrinkage to occur. Conversely, where in-home relative humidity exceeds 70% for extended periods of time, expansion could occur. In certain geographic locations of the country, it is natural for the humidity to reach and remain at 80% for several weeks during the new construction period. Exposure to sustained conditions such as these could cause opening of the joints, in which case product would not be considered defective.

Aristokraft recommends product be stored and installed in an atmosphere where the humidity level and temperature are controlled.

### Humidification Effects on a Door with a Miter Joint

#### High Humidity

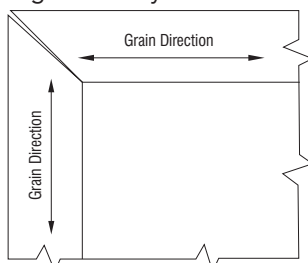

When wood swells,  
miter joints open as shown above.

#### Low Humidity

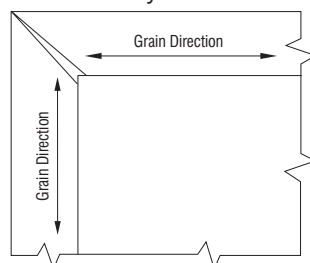

When wood shrinks,  
miter joints open as shown above.

### Steps Consumers Can Take To Protect Real Wood Furnishings

- **Keep an eye on the humidity inside the home.** Reasonably accurate digital thermometers-hygrometer units are available to measure humidity.
- **Maintain the humidity at or above 20% when the temperature is below 20 degrees and over 35% when the temperature is above 20 degrees.** Some ways this may be accomplished are installing a whole-house humidifier on the furnace, running a portable humidifier in key rooms, or placing pans of water near the heat registers.
- **Don't over do it.** Significant condensation on windows is a sign the humidity levels are too high for outside temperature conditions.
- **Recognize that finished wood responds to humidity over a period of several days to several weeks.** It takes time before the wood returns to normal after any correction to the environment.

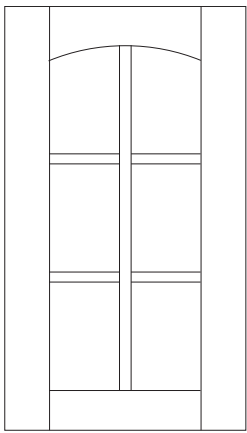

Standard Mullion Arch

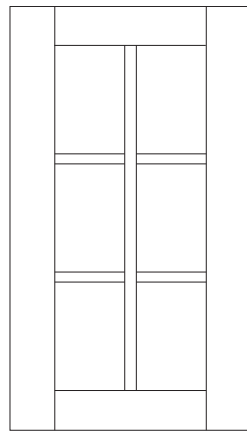

Standard Mullion Square

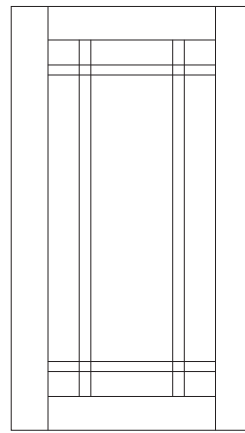

Shaker Mullion  
Benton, Harrison,  
& Winstead Only

- ▶ Custom door sizes not available.
- ▶ Mullion Door cabinets are not available in Ellsworth, Teagan, and VanWyke.
- ▶ Cabinets with Mullion Doors include installed, clear tempered glass, and matching Aristex® interior.
- ▶ Specify L or R on all single door Arch styles.
- ▶ For complementary Wall Mullion Door cabinet in Teagan order as Winstead Maple, as Teagan features a slab door design.

Mullion Door Grid Configurations

Refer to drawings below to see the Standard & Shaker configurations for cabinet width & height.

STANDARD MULLION DOOR GRID CONFIGURATIONS					
Cabinet Width	Cabinet Height				
	21"	24"	30"	36"	42"
15"			A	A	A
18"			A	A	A
21"			A	A	A
24"			A	A	A
30"	B	B	A	A	A
36"	A	B	A	A	A
24" Diagonal			A	A	A
27" Diagonal			A	A	A

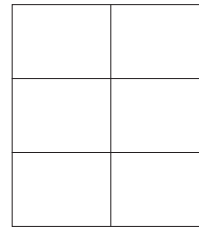

A

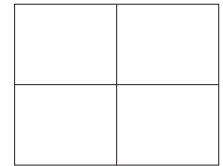

B

Available Door Styles:

Augusta, Avalon, Ayden, Briarcliff II, Dryden, Durham, Eastland, Grayson, Landen, Nantucket, Oakland, Overton, Pioneer, Radford, Saybrooke, Sinclair, Wentworth, Westbury

SHAKER MULLION DOOR GRID CONFIGURATIONS					
Cabinet Width	Cabinet Height				
	21"	24"	30"	36"	42"
15"			C	C	C
18"			C	C	C
21"			C	C	C
24"			C	C	C
30"	B	C	C	C	C
36"	A	C	C	C	C
24" Diagonal			C	C	C
27" Diagonal			C	C	C

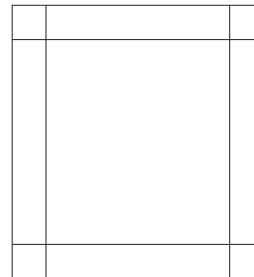

C

Available Door Styles:

Benton, Harrison, Winstead

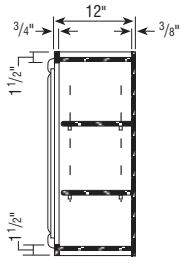

**Wall Cabinet**

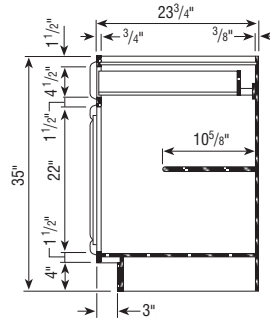

**Base Cabinet**

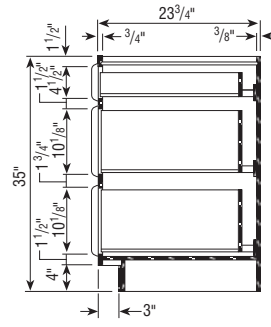

**3-Drawer  
Base Cabinet**

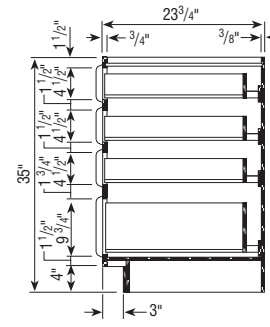

**4-Drawer  
Base Cabinet**

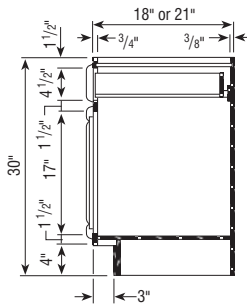

**30" High  
Vanity Cabinet**

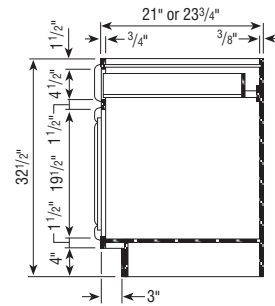

**32 1/2" High  
Base/Vanity**

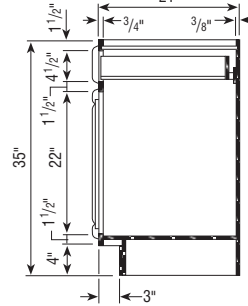

**35" High  
Vanity Cabinet**

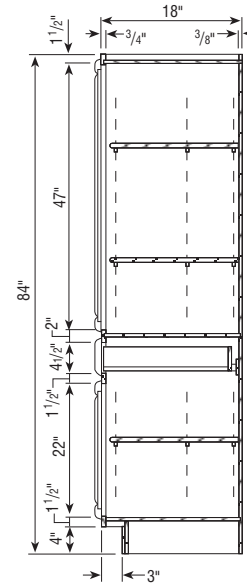

**Linen Closet w/Drawer**

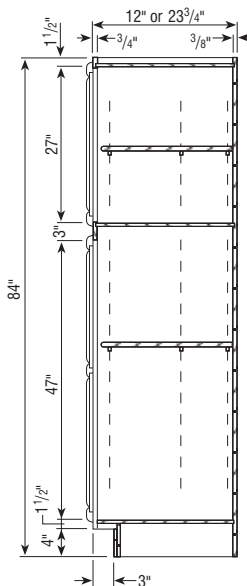

**Utility Cabinet**  
Shelves not included with  
30" & 36" wide cabinets.

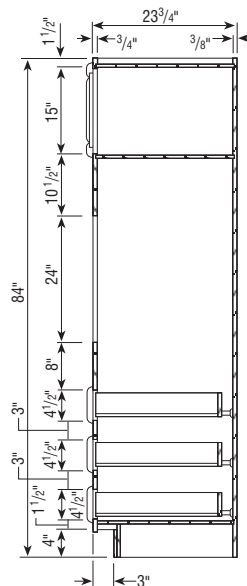

**Double Oven Cabinet**

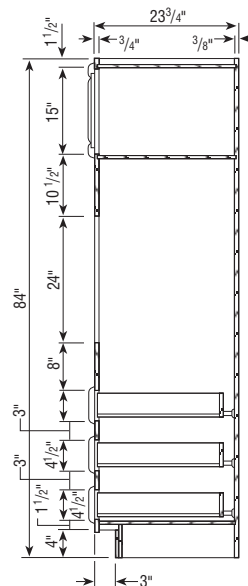

**Single Oven Cabinet**  
7/16" Overlay Styles

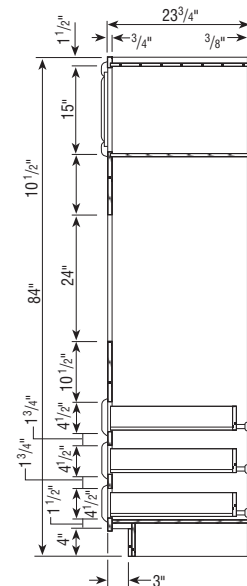

**Single Oven Cabinet**  
1/4" Overlay Styles

# Cabinet Specification Reference

- ▶ Number above wall cabinet represents height of cabinet.
- ▶ 1 1/2" Top and Bottom Rails on most cabinets.
- ▶ 1 1/2" Vertical Stiles on most cabinets, except OC/OCD Cabinets.
- ▶ 3" wide Center Mullion on Double Door Cabinets, only where applicable. See page 17 for style availability.
- ▶ Drawer Box opening heights are 4 1/2" for small and 9 3/4" or 10 1/8" for large (deep) drawers.

## 7/16" Overlay Door Styles:

- ▶ 1 1/16" Reveal around doors (1 1/16" of Face Frame shows).
- ▶ Door size for Single Door and Center Mullion Cabinets: Frame opening + 7/8"
- ▶ Door size for Butt Door Cabinets: (Frame opening + 3/4")/2
- ▶ 4 1/2" High Drawer opening = 5 1/8" Drawer Front.

## Full Overlay Door Styles:

- ▶ 1/4" Reveal around doors (1/4" of Face Frame shows).
- ▶ Door size for Single Door Cabinets: Frame opening + 2 1/2"
- ▶ Door size for Butt Door Cabinets: (Frame opening + 2 3/8")/2
- ▶ 4 1/2" High Drawer opening = 5 3/4" Drawer Front.

## 84" High Application

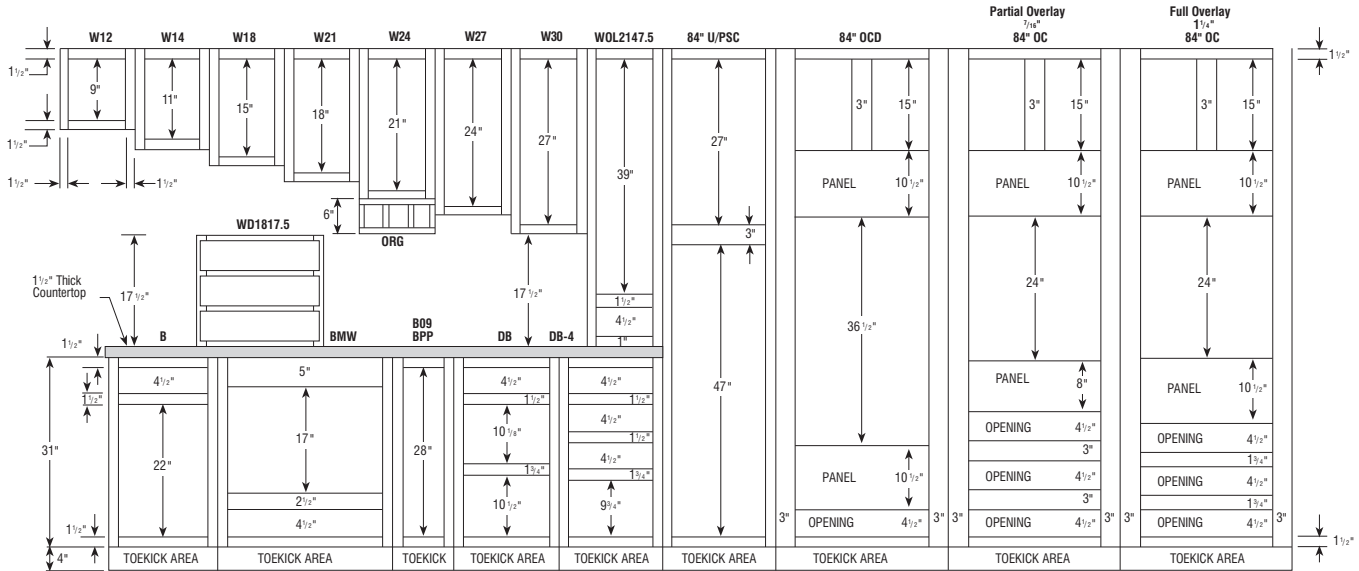

## 90" High Application

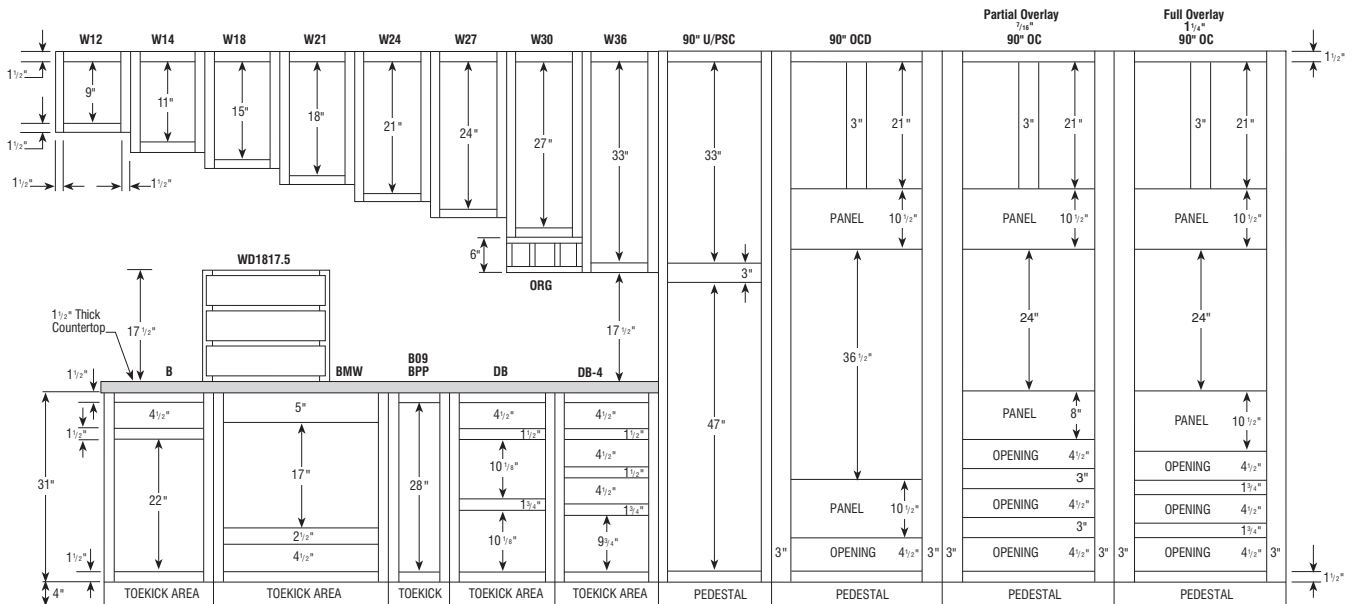



### 32 1/2" High Vanity Cabinets

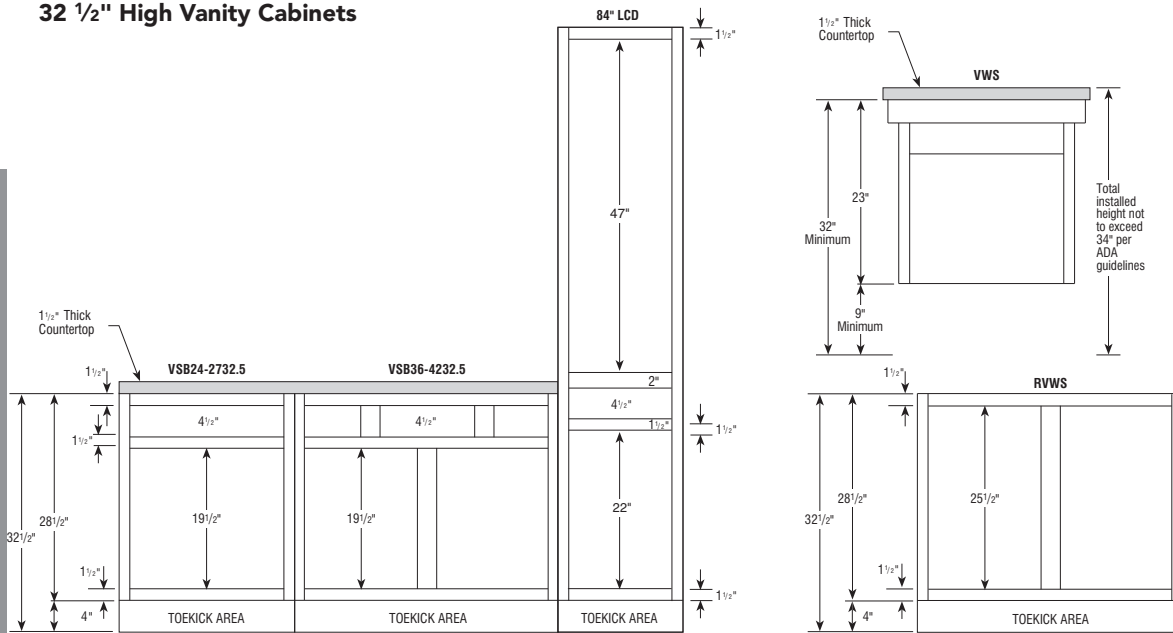

### 35" High Vanity Cabinets

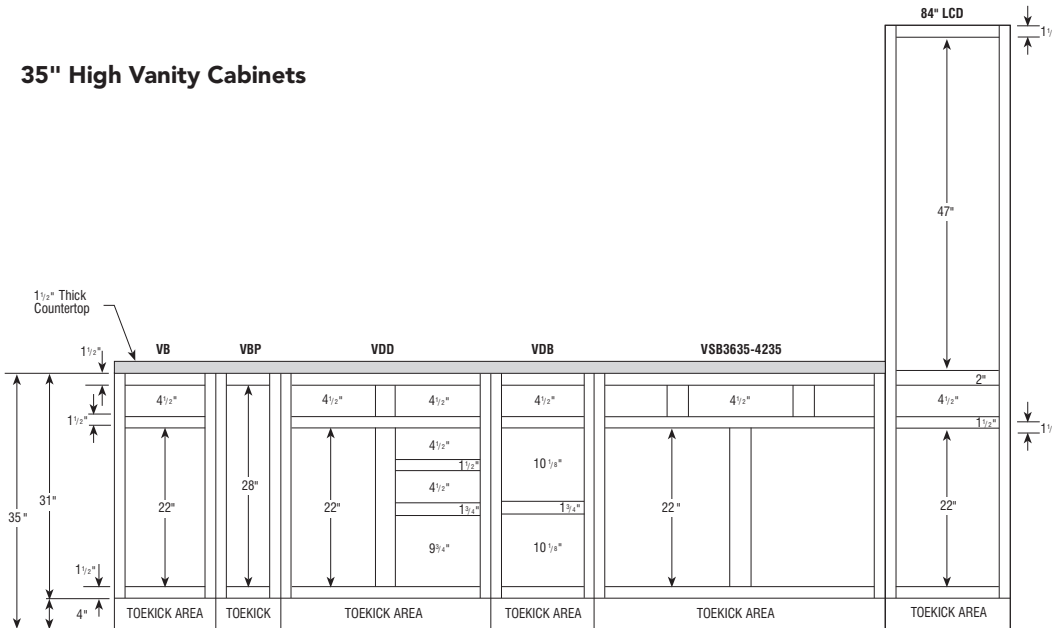

### 32 1/2" High Base Cabinets (Universal Design Application)

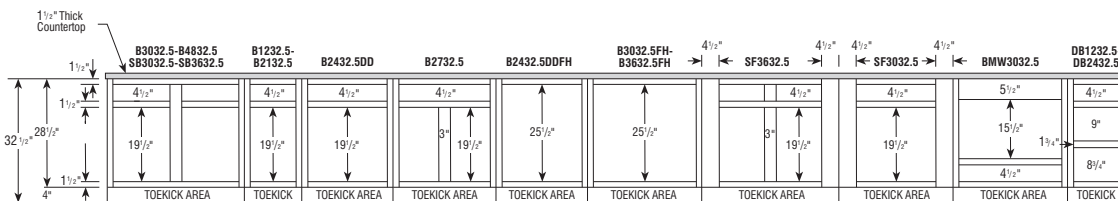

- ▶ 32 1/2" High Cabinets are designed to comply with ADA (Americans with Disabilities Act) requirements of a 34" high overall counter height, including a 1 1/2" counter top.
- ▶ Refer to ADA guidelines for more details on designing in small spaces where extra width for turning radius may be required.
- ▶ Available in the following styles:
  - ▶ Avalon Maple
  - ▶ Benton Birch
  - ▶ Landen Maple
  - ▶ Landen Oak
  - ▶ Oakland Oak
  - ▶ Saybrooke Birch
  - ▶ Sinclair Birch
  - ▶ Westbury Oak
- ▶ For Vanity Sink Base Cabinets, see page 114. For a Vanity Wall Sink Cabinet, see page 134.

## Did you remember...

### Styles and Pricing

- ▶ Select Door Style and Pricing Level from your 20/20 design program. (If copying and pasting from one order to another, remember to reset styles and pricing.)

### End Finishing Options

Consider exposed end options:

- ▶ Use APC for exposed cabinets. The veneer finished end will age uniformly with the rest of the kitchen.
- ▶ Apply  $\frac{3}{16}$ " veneer skin to hide  $\frac{3}{16}$ " reveal. This will allow the ends to age uniformly with the rest of the kitchen and will make it flush.
- ▶ Apply decorative door kit (DBEP, DWEP, DVEP). This kit includes  $\frac{3}{16}$ " veneer skin, decorative doors, and screws for field installation.
- ▶ Underside of Wall Cabinets are natural maple laminate, with a few exceptions, such as WMD, WOL, WPG, or white cabinets. Use light rail and skin to hide, especially when designing with Peninsula Wall Cabinets.

### Wood and Finish Characteristics

Review specific details with the customer:

- ▶ Mineral Streaks, Birdseye Dots, Grain Variations (especially Hickory and Rustic Birch).
- ▶ Color Variations/Darkening (especially Cherry).
- ▶ Finish Variations (Glazes are "consistently inconsistent"), hairline cracks may develop at frame joints on painted frames.

### Clearances

- ▶ Add fillers between end cabinets and walls on full overlay door styles.
- ▶ Allow space between door/window trim and end cabinets for countertop and top moulding overhang.
- ▶ Include refrigerator door hinges in overall refrigerator height when placing cabinets above it.
- ▶ For minimum pull requirements on blind corner cabinets, see charts on pages 73, 91, and 94.
- ▶ Allow sufficient clearance (3") on each side of accessory cabinets (such as roll-out trays, swingout units, etc).
- ▶ Doors on these cabinets must open fully for accessories to be functional.
- ▶ Ensure the height between the cooktop and range hood is 24" to meet NKBA guidelines.

Advise customer carefully on upper cabinet/microwave advantages/disadvantages as follows:

- ▶ Minimum of 18" from cooktop to upper cabinet/above the range microwave which allows for easy access to either, but less room over back burner.
- ▶ Minimum of 21" from cooktop to upper cabinet/microwave which allows for access to large pots on back burner of cooktop, but longer reach to microwave.

### Fillers

- ▶ Place fillers toward end of run where least conspicuous if needed.
- ▶ Attach overlay fillers on top of base, wall, or tall fillers when using full overlay door styles to maintain a consistent reveal. Don't forget to include blind corner fillers.

### Matching Interior Cabinets/Glass Options

- ▶ Use light rail and skin to hide color variation between bottom of WOL Cabinets next to any other cabinets.
- ▶ Verify mullion door grid matches customer expectations. (Advise customer of shaker grid pattern.)

### Mouldings

- ▶ All toekicks must be skinned with TOEKICK or TOEKICK8.
- ▶ Verify the correct amount of moulding has been ordered.
- ▶ Order toekick caps.
- ▶ Order extra scribe.

### Islands and Peninsulas

- ▶ Consider standard height bars are 35" tall and require 19" knee space. Raised bars are 42" tall.
- ▶ Consider Base Peninsula Cabinets (PB) are 23 $\frac{3}{4}$ " deep and require 12" of knee space.
- ▶ Use outside corner moulding if a skin is exposed on the back of the island.

### Appliances

- ▶ Do not place dishwashers next to diagonal front cabinet (interference) or next to a range (no countertop support).
- ▶ Verify refrigerator door has enough clearance to open beyond 90 degrees so refrigerator drawers can be utilized. Refer to appliance manufacturer's specifications.
- ▶ Thermofoil will not withstand sustained temperatures in excess of 170°F. A 3" filler or heat shield is required between any thermofoil surface and any heat source to be in compliance with cabinet warranty.

### Special Considerations

- ▶ Consider V-Groove skins and/or decorative doors on exposed cabinet sides in glazed kitchen.

### Miscellaneous

- ▶ Order touch-up kit for future repairs.

### Tips to the Installer

#10 x 2 $\frac{1}{2}$ " installation screws are furnished and packaged inside all cabinets for attachment to wall. Proper wall stud or ceiling joist installation is essential for Wall and Peninsula Cabinets to support weight. Whenever possible, cabinets should be attached to each other for additional strength. Excessive weight should not be put on cabinets hung by themselves. Shimmiing may be required to ensure proper alignment. Wallboard alone is not strong enough to support the cabinets.

Aristokraft's Warranty does not cover damage caused by improper installation. Please be sure to install cabinets properly and review all installation instructions. If you have questions, please contact your representative or customer service.

### Wood Dust Warning

When cutting, sanding, sawing, or shaping cabinets or wood products, you are likely to generate wood dust. For your own safety, Aristokraft recommends that you wear a protective mask to prevent breathing wood dust. We also recommend eye protection to avoid injury by flying wood chips or sawdust during cabinet installation.

## Kitchen Planning Guidelines

### Door/Entry

- ▶ Door opening should be at least 32" wide.

### Door Interference

- ▶ Entry door should not interfere with safe appliance operation or appliance doors.

### Distance Between Work Centers

- ▶ With three work centers, the total distance traveled should not be more than 26' with no single leg of the triangle less than 4' or more than 9'.
- ▶ With more than three work centers, each additional travel distance to another work center should be no less than 4' or more than 9'. Each leg is measured from the center-front of the appliance/sink. No work triangle leg should intersect an island/peninsula by more than 12".

### Separating Work Centers

- ▶ A tall obstacle should not separate two primary work centers. A properly recessed tall corner unit is acceptable.

### Work Triangle Traffic

- ▶ Major traffic patterns should not cross through the basic work triangle.

### Work Aisle

- ▶ The work aisle should be at least 42" for one cook and at least 48" for multiple cooks.

### Walkway

- ▶ The walkway width should be at least 36".

### Traffic Clearance At Seating

- ▶ Allow 32" of clearance from the table to wall/obstacle if no traffic passes behind a seated diner. If traffic passes behind the diner, allow at least 36" to edge past or 44" to walk past.

### Seating Clearance

- ▶ 30" high tables/counters should allow a 24" wide by 18" deep space for each seated diner.
- ▶ 36" high counters should allow a 24" wide by 15" deep space for each seated diner and at least 15" kneespace.
- ▶ 42" high counters should allow a 24" wide by 12" deep space for each seated diner and at least 12" kneespace.

### Clean-Up/Prep Sink Placement

- ▶ With only one sink, locate it adjacent to or across from the cooking surface and refrigerator.

### Clean-Up/Prep Sink Landing Area

- ▶ Include at least a 24" landing space on one side of the sink and 18" on the other.
- ▶ If all the countertop at the sink is not the same height, plan a 24" landing space on one side of the sink and 3" of countertop frontage on the other, both at the same height of the sink.

### Preparation/Work Area

- ▶ Include a section of countertop at least 36" wide x 24" deep next to the sink for a work area.

### Dishwasher Placement

- ▶ Nearest edge of dishwasher should be within 36" of nearest edge of sink. Provide at least 21" of standing space between the edge of the dishwasher and countertop frontage/appliances/cabinets which are placed at a right angle to the dishwasher.

### Waste Receptacles

- ▶ Include at least 2 waste receptacles, one near the sink and the other nearby for recycling.

### Auxiliary Sink

- ▶ Provide at least 3" of countertop frontage on one side of the auxiliary sink and 18" on the other side, both at the same height of the sink.

### Refrigerator Landing Area

- ▶ Include at least 15" of landing area on the handle side of the refrigerator, 15" on either side of a side-by-side refrigerator, 15" of landing space which is no more than 48" across from the front of the refrigerator, and 15" above or adjacent to any under counter-style refrigerator.

### Cooking Surface Landing Area

- ▶ Include a minimum of 12" of landing area on one side of the cooking surface and 15" on the other.
- ▶ If cooking surface is at a different countertop height than the rest of the kitchen, then the 12" and 15" landing areas must be the same height as the cooking surface.
- ▶ For safety reasons, in an island or peninsula situation, the countertop should extend a minimum of 9" behind the cooking surface if the counter height is the same height as the cooking surface.

### Cooking Surface Clearance

- ▶ Allow 24" between the cooking surface and a protected noncombustible surface above it.
- ▶ At least 30" of clearance is required between the cooking surface and an unprotected/combustible surface above it.
- ▶ If a microwave hood is used, then the manufacturer's specifications should be followed.

### Cooking Surface Ventilation

- ▶ A correctly sized, ducted ventilation system is recommended for all cooking surface appliances. The recommended minimum is 150 CFM.
- ▶ Code requires that the manufacturer's specifications be followed. Minimum exhaust rate for a ducted hood is 100 CFM and must be ducted to the outside.
- ▶ Make-up airway may need to be provided. Refer to local codes.

### Cooking Surface Safety

- ▶ Do not locate cooking surface under an operable window.
- ▶ Window treatments above cooking surface should not use flammable materials.
- ▶ Place a fire extinguisher near the kitchen exit away from cooking equipment.

### Microwave Oven Placement

- ▶ The ideal location for the bottom of the microwave is 3" below the principle user's shoulder, but no more than 54" above the floor.

## Kitchen Planning Guidelines (continued)

### Microwave Landing Area

- ▶ Provide at least 15" above, below, or adjacent to the handle side of a microwave oven.

### Oven Landing Area

- ▶ Include at least 15" next to or above the oven.
- ▶ A 15" landing area that is not more than 48" away is also acceptable as long as the oven does not open into a walkway.

### Combining Landing Areas

- ▶ If two landing areas are adjacent to one another, determine a new minimum for the two by taking the longer of the two and adding 12".

### Countertop Space

- ▶ A total of 158" of countertop frontage, 24" deep, with at least 15" clearance above is needed to accommodate all landing, preparation, work, and storage areas.

### Countertop Edges

- ▶ Clipped or round corners rather than sharp edges are recommended on all counters.

### Storage

- ▶ The recommended total shelf/drawer frontage for a small kitchen (less than 150 square feet) is 1400", a medium kitchen (151 to 350 square feet) is 1700", and for a large kitchen (greater than 350 square feet) is 2000".

Sizes:	S	M	L
Wall	300"	360"	360"
Base	520"	615"	660"
Drawer	360"	400"	525"
Pantry	180"	230"	310"
Misc.	40"	95"	145"

- ▶ The totals for wall, base, drawer, and pantry shelf/drawer frontage can be adjusted upward or downward as long as the recommended total stays the same.

### Storage At Clean-Up/Prep Sink

- ▶ The recommended total for a small kitchen is 400", a medium kitchen is 480", a large kitchen is 560", and should be located within 72" of the centerline of the main clean-up/prep sink.

### Corner Cabinet Storage

- ▶ At least one corner cabinet should include a functional storage device.

### Electrical Receptacles

- ▶ GFCI (Ground-Fault-Circuit-Interruptor) protection is required on all receptacles servicing countertop surfaces within the kitchen.

### Lighting

- ▶ Every work surface should be well illuminated. At least one wall switch-controlled light must be placed at the entrance.
- ▶ Window/skylight area, equal to at least 8% of the total square footage of the kitchen, or a total living space which includes a kitchen, is required.

## Bathroom Planning Guidelines

### Door/Entry

- ▶ Doorway opening should be at least 32", requiring a minimum 2' 10" wide door.

### Door Interference

- ▶ Entry or fixture doors should not interfere with each other and/or the safe use of fixtures/cabinets.

### Ceiling Height

- ▶ Bathroom floor to ceiling minimum height is 80". A shower or tub with a shower head shall have a minimum floor to ceiling height of 80" above a minimum area 30" x 30" at the shower head.

### Clear Space

- ▶ Plan a clear space of 30" from the front edge of all fixtures to any opposite bath fixture, wall, or obstacle.
- ▶ A minimum space of at least 21" is required in front of lavatory, toilet, bidet, and tub, with a 24" minimum space in front of a shower entry.

### Single Lavatory Placement

- ▶ The distance from the centerline of the lavatory to the sidewall/tall obstacle should be at least 20".
- ▶ The minimum distance required is 15". The minimum distance required between a wall and the edge of a lavatory is 4".

### Double Lavatory Placement

- ▶ The distance between the centerlines of two lavatories should be at least 36".
- ▶ The minimum distance required is 30".
- ▶ The minimum distance required between the edges of two lavatories is 4".

### Lavatory/Vanity Height

- ▶ The height for a lavatory varies between 32"–43" to fit the user.

### Countertop Edges

- ▶ Clipped or round corners rather than sharp edges are recommended on all counters.

### Shower Size

- ▶ The interior shower size should be at least 36" x 36". The minimum interior shower size required is 30" x 30".

# Organization Solutions



Look for the symbol (shown left) used throughout this book indicating organization solutions. Reference the chart below for organization applications.

		CABINET WIDTH																PAGE
		3"	6"	9"	12"	15"	18"	21"	24"	27"	30"	33"	36"	39"	42"	45"	48"	
<b>WALL CABINETS</b>																		
ACS_17.5	Appliance Centers - Straight						✓		✓	✓								154
AC2417.5	Appliance Center - Diagonal								✓†									154
DCR2430	Diagonal Corner Roto Wall Cabinet								✓†									71
MWC30_	Microwave Wall Cabinets (36" & 48" High)										✓							60
MWC30_	Wall Built-In Microwave Cabinets (36" & 42" High)										✓							61
SRD_	Wall Spice Racks (Wall Cabinet Accessory)					✓	✓	✓										156
WD1817.5	Wall Drawer Unit						✓											59
WER24_	Wall Easy Reach Cabinets								✓†									71
WMC12_	Wall Message Center Cabinets	✓																60
<b>BASE CABINETS</b>																		
B_RT	Base Cabinets w/ Roll Trays					✓	✓	✓	✓	✓	✓	✓	✓	✓	✓	✓	✓	78
B_RT-2	Base Cabinets w/Double Roll Trays					✓	✓	✓	✓	✓	✓	✓	✓	✓	✓	✓	✓	79
B12TDRO	Base Cabinet w/Rollout Tray Divider			✓														82
B30RT-2LO	Base w/Double Roll Trays & Lid Organizer										✓							79
BBCPO6 <i>New</i>	Base Box Column Pullout Cabinet		✓															81
BEC12	Base End Cabinet (One Door)				✓													92
BECF24	Base End Cabinet (Two Doors)								✓									92
BLS_	Base Lazy Susan Cabinets											✓†	✓†					90
BMW3035	Base Built-In Microwave Cabinet										✓							89
BPP09	Base Pantry Pullout Cabinet			✓														82
BPPP24	Base Pots & Pans Pullout								✓									83
BRER36	Base Roto Easy Reach Cabinet												✓†					89
BSC30PRP, RP	Base SuperCabinets™										✓							80
BSC36PRP	Base SuperCabinets™											✓						80
BWB_	Base Wastebaskets						✓	✓										84
BWB15FH	Base Wastebasket w/Full Height Door					✓												83
SB_ STS	Sink Base SuperCabinets™										✓		✓					85
SCER36	Square Corner Easy Reach Cabinet												✓†					89
SCR_	Square Corner Roto Cabinets												✓†	✓†				90
<b>TALL CABINETS</b>																		
PSC_	Pantry SuperCabinets™ (84", 90", 96" Tall)					✓	✓		✓		✓		✓					101
U_	Utility Cabinets (84", 90", 96" Tall - 23¾" Deep)					✓	✓		✓		✓		✓					103
U_ 12	Utility Cabinets (84", 90", 96" Tall - 12" Deep)					✓	✓		✓		✓		✓					103
<b>VANITY CABINETS</b>																		
LCD_	Linen Closets w/Drawer (21" Deep)						✓		✓									125
LCD_18	Linen Closets w/Drawer (18" Deep)						✓		✓									124
LCD18SC	Linen Closet w/Removable Hamper						✓											125
VBP0935	Vanity Base Pullout			✓														111
VSB_35STS	Vanity Sink Base SuperCabinets™										✓		✓					119
<b>ACCESSORIES</b>																		
CBK	Cutting Board Kit						✓						✓					157
CT_	Cutlery Trays (Drawer Accessory)					✓	✓	✓	✓									157
DWBR	Double Wastebasket Rollout (Fits: 15" Bases)					✓												163
PDO	Pegged Dish Organizer												✓					157
UPK_	Pantry Rollout Kits					✓	✓		✓		✓		✓					162

†Solutions for the corner.

### Desk A

6' wide, 7'2" high

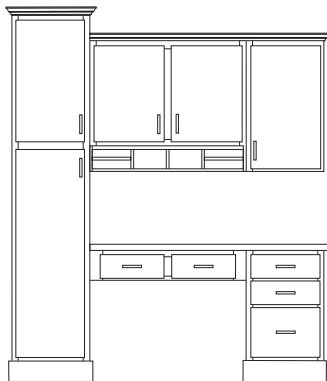

- Including:**
- Qty Cabinet List**
- 1 U18-L
  - 1 W3624
  - 1 W1830-R
  - 1 VFD18
  - 1 VDT36

- Qty Trim List**
- 1 ORG36
  - 2 MSW8
  - 2 MFOLCR8
  - 2 MBS8

Wet Bars

### Wet Bar A

7' wide, 7'7" high

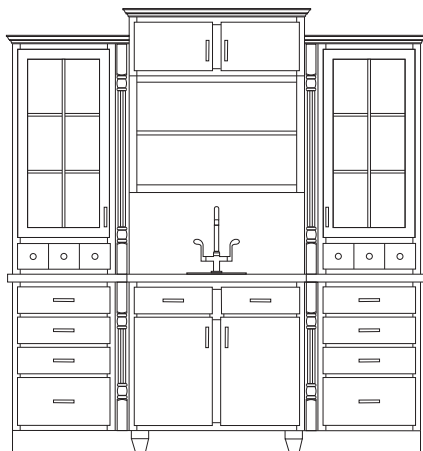

- Including:**
- Qty Cabinet List**
- 2 DB21-4
  - 1 SB36
  - 2 WOL2147.5
  - 1 WOL3624
  - 1 WMD2142-L (door only)
  - 1 WMD2142-R (door only)
  - 1 W3612

- Qty Trim List**
- 1 PA4896
  - 1 TOEKICK8
  - 2 MFOLCR8
  - 2 MSW8
  - 2 F331
  - 4 SPTRINGEND (pair)
  - 2 REED96
  - 2 TAPLEG<sup>†</sup>
  - 1 PREPR33096

<sup>†</sup>Tapered legs not available in Oak and Hickory.

### Wet Bar B

6' wide, 6'10" high

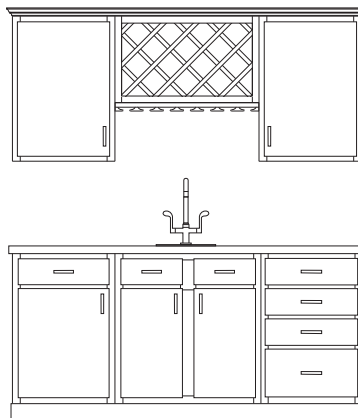

- Including:**
- Qty Cabinet List**
- 1 B21
  - 1 SB30
  - 1 DB21-4
  - 1 W2130-L
  - 1 W2130-R

- Qty Trim List**
- 1 WR3018
  - 1 SGH30
  - 2 MBS8
  - 2 MFOLCR8
  - 2 MSW8

► Use butt door product codes where applicable. See page 17 for style availability.  
 ► For a complete installation sheet on any Room Solutions designs contact Customer Service or download from the Marketing Center on [www.mbc1touch.com](http://www.mbc1touch.com).

### Hutch A

5'6" wide, 7'2" high

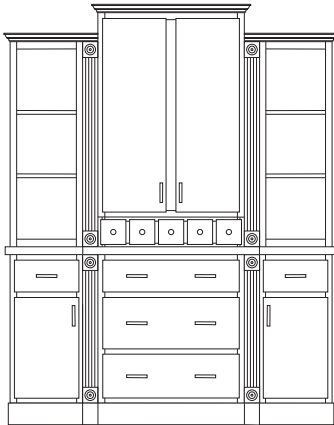

**Including:**

**Qty Cabinet List**

- 2 B15
- 1 DB30
- 1 W3042
- 2 WOL1542

**Qty Trim List**

- 1 WCUBE30
- 1 WCUBEDRW5
- 1 PA4896
- 2 MSW8
- 2 MFOLCR8
- 2 MBS8
- 2 FF331
- 8 FFROS3X3
- 1 FF396
- 2 PSFEP

### Hutch B

6'6" wide, 7'8" high

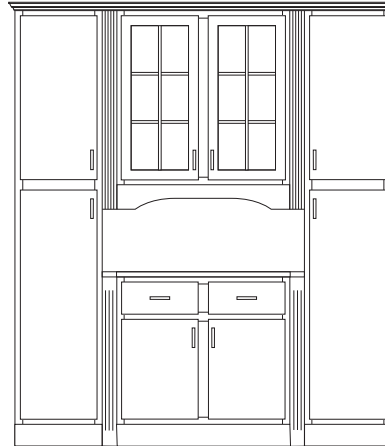

**Including:**

**Qty Cabinet List**

- 1 B36RT
- 1 WMD3636
- 1 U1890-L
- 1 U1890-R

**Qty Trim List**

- 1 F531A45 (pair)
- 1 FF396
- 1 V537RA
- 1 TOEKICK8
- 3 MFOLCR8
- 3 MSW8

### Hutch C

3'6" wide, 7'8" high



**Including:**

**Qty Cabinet List**

- 1 DB36
- 1 W1836-L
- 1 W1836-R
- 2 WD1817.5

**Qty Trim List**

- 2 PREPR33096
- 4 SPTRINGEND (pair)
- 2 REED96
- 1 TOEKICK8
- 2 MSW8
- 2 MFOLCR8

► Use butt door product codes where applicable. See page 17 for style availability.  
 ► For a complete installation sheet on any Room Solutions designs contact Customer Service or download from the Marketing Center on [www.mbc11touch.com](http://www.mbc11touch.com).

### Island A

5'6" wide, 36 1/2" high, 35 3/4" deep

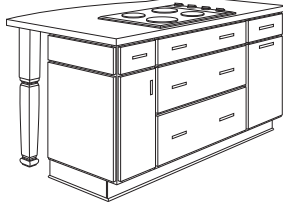

**Including:**

Qty	Cabinet List	Qty	Trim List
1	B12TDRO-L	1	PDO
1	DB36FX	1	ISLEGSQ
1	BWB18	1	DBEP-L
1	B18FH-12-L (located on back side of island)	1	BP4896
2	B18 (door only)	1	MCV8
2	B18 (drawer only)	1	MOCW8
		3	MQR8
		2	TOEKICK8

### Island C

5'6" wide, 36 1/2" high, 44 3/4" deep

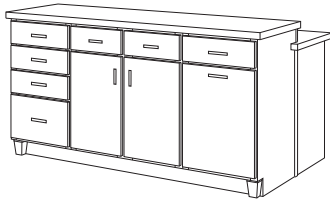
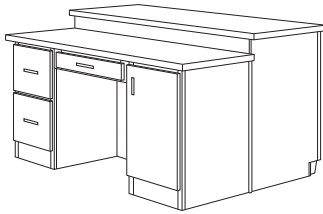

**Including:**

Qty	Cabinet List	Qty	Trim List
1	VFDB18	2	TAPLEG
1	KDT30	1	MBAT8
1	BKB1830-R	1	PA4836
1	DB18-4FX	2	MSW8
1	B30RT	1	TOEKICK8
1	BWB18		

### Island D

5' wide, 36 1/2" high, 35 3/4" deep

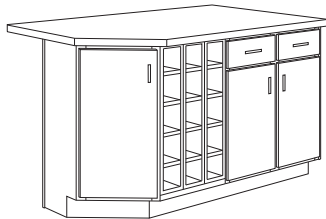

**Including:**

Qty	Cabinet List	Qty	Trim List
1	BEC12-L	5	WCUBE30
1	B30RT-2LO	1	P4836
1	B18FH-12-R	1	MCV8
		2	MOCW8
		2	MSW8
		2	TOEKICK8
		2	P4836
		1	F330

► Use butt door product codes where applicable. See page 17 for style availability.  
 ► For a complete installation sheet on any Room Solutions designs contact Customer Service or download from the Marketing Center on [www.mbc1touch.com](http://www.mbc1touch.com).

NOTES ✓

- ▶ To create the Americana design, start with F396 and add MICROWN8 and MROPE8 insert.
- ▶ To create the Art Linea design, start with MCTB8, add MBAT8 and another MCTB8 and support with cleat.

Americana

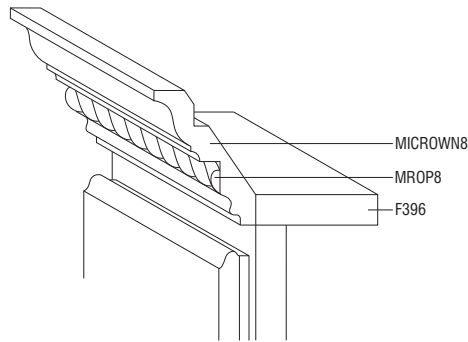

Art Linea

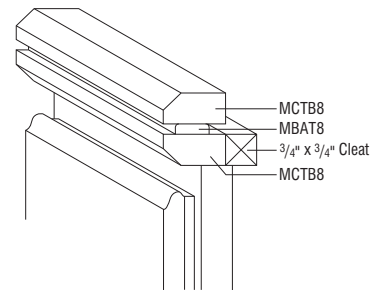

NOTES ✓

- ▶ To create the Aztec design, start with F396 and add MFOLCR8 and MMENTIL8 insert.
- ▶ To create the Baroque design, start with F396 and add MFOLCR8 and MROPE8 insert.

Aztec

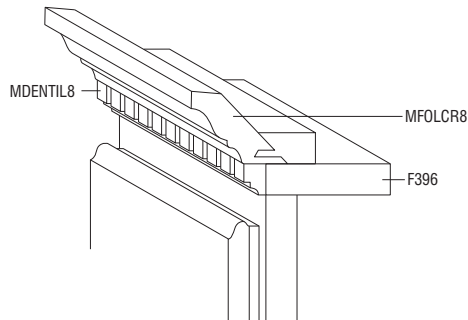

Baroque

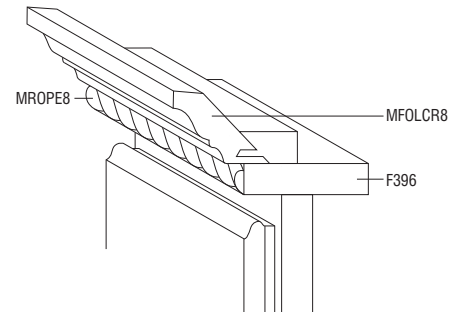

NOTES ✓

- ▶ To create the Georgian design, start with MBS8 and add MCROWN8 and support with cleat.
- ▶ To create the Classical design, start with MTST8 and add F396 cut to 1 1/2\"/>

Georgian

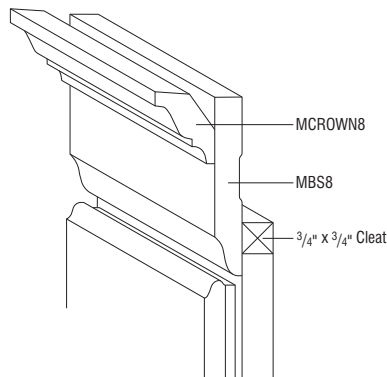

Classical

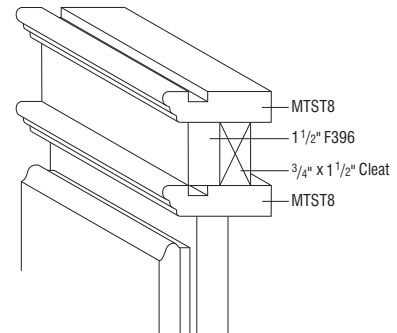

## Mission

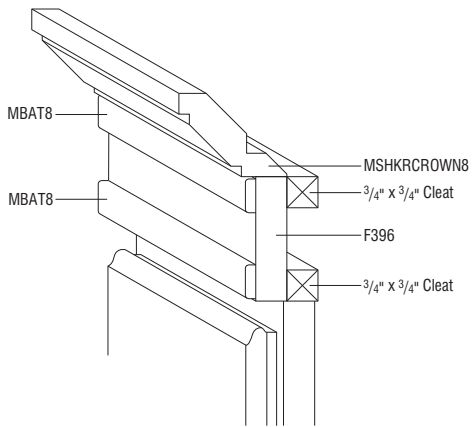

## Monticello

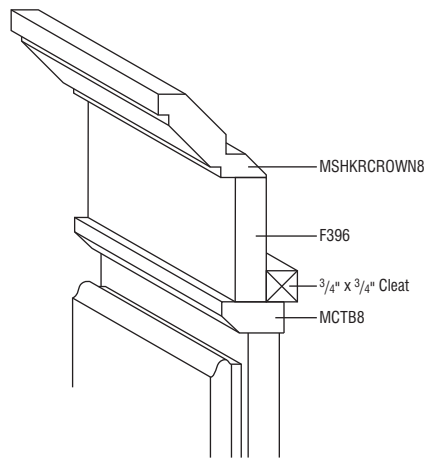

### NOTES ✓

- ▶ To create the Mission design, start with F396 and add two MBAT8 and MSHKRCROWN8 and support with cleat.
- ▶ To create the Monticello design, start with MCTB8 and add F396 and MSHKRCROWN8 and support with cleat.
- ▶ Available in Maple finishes only.

## Monarch

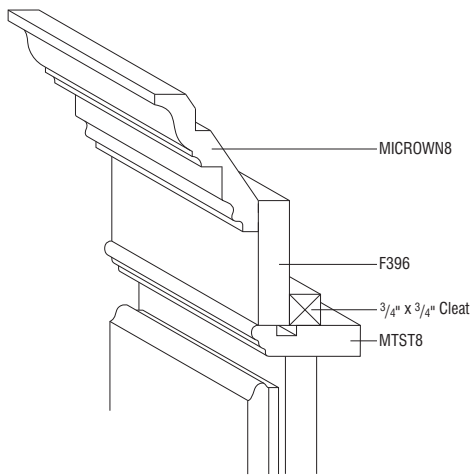

## Regency

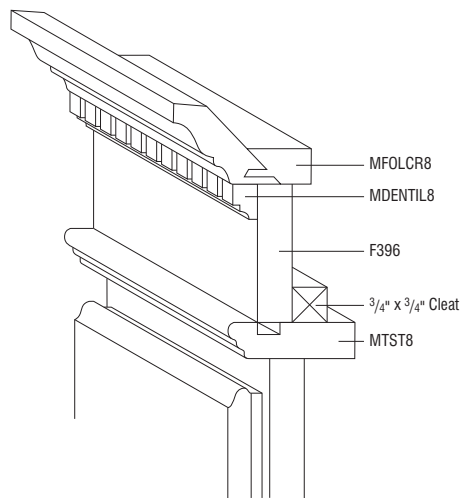

### NOTES ✓

- ▶ To create the Monarch design, start with MTST8 and add F396 and MICROWN8 and support with cleat.
- ▶ To create the Regency design, start with MTST8 and add F396 and MFOLCR8 and MDENTIL8 insert and support with cleat.

## Renaissance

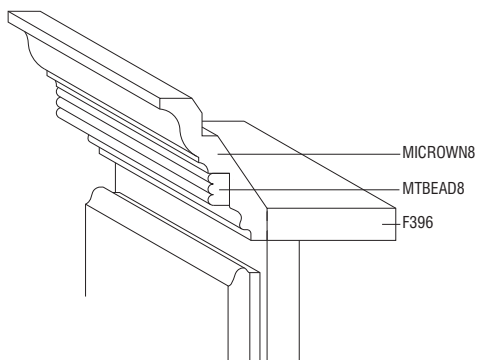

## Romanesque

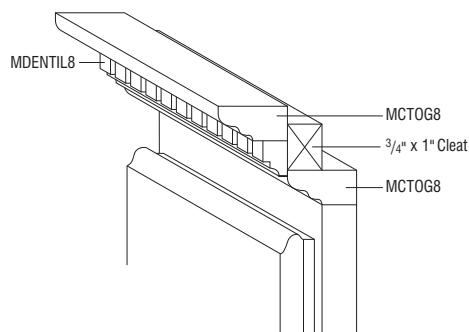

### NOTES ✓

- ▶ To create the Renaissance design, start with F396 and add MICROWN8 and MTBEAD8 insert.
- ▶ To create the Romanesque design, start with MCTOG8 and add another MCTOG8 and MDENTIL8 insert and support with cleat.

### Wall Cabinets, 12" High, 12" Deep

**NOTES** ✓

- ▶ Shelves not included.
- ▶ Cabinets use standard natural maple interior, excluding white which has a white interior.
- ▶ Center door on W4212, W4512, and W4812 will be hinged on the left.

**DESIGN SOLUTIONS**

- ▶ Apply an End Panel Skin to create a flush end on the side of a Wall cabinet if installed at the end of a run for ease of Moulding installation.

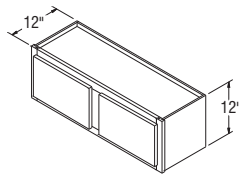

**W3012**  
**W3312**  
**W3612**  
**W3912**

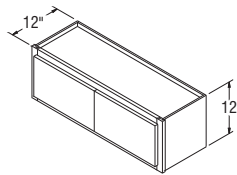

**W3012B**  
**W3312B**  
**W3612B**

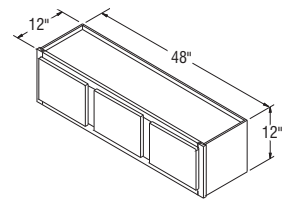

**W4212 New**  
**W4512 New**  
**W4812**

### Wall Cabinets, 14" High, 12" Deep

**NOTES** ✓

- ▶ Shelves not included.
- ▶ Cabinets use standard natural maple interior, excluding white which has a white interior.
- ▶ Center door on W4214 and W4814 will be hinged on the left.

**DESIGN SOLUTIONS**

- ▶ Apply an End Panel Skin to create a flush end on the side of a Wall cabinet if installed at the end of a run for ease of Moulding installation.

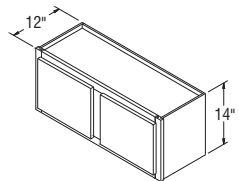

**W3014**  
**W3314**  
**W3614**  
**W3914**

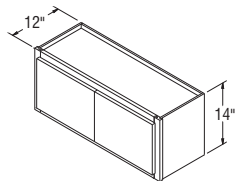

**W3014B**  
**W3314B**  
**W3614B**

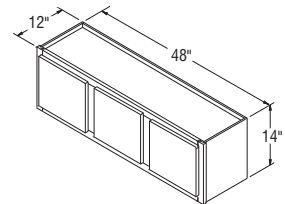

**W4214 New**  
**W4814 New**

### Wall Cabinets, 18" High, 12" Deep

**NOTES** ✓

- ▶ Shelves not included.
- ▶ Cabinets use standard natural maple interior, excluding white which has a white interior.

**DESIGN SOLUTIONS**

- ▶ Apply an End Panel Skin to create a flush end on the side of a Wall cabinet if installed at the end of a run for ease of Moulding installation.

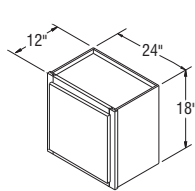

**W2418\***

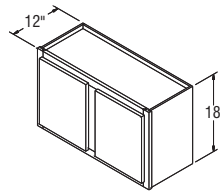

**W2718**  
**W3018**  
**W3318**  
**W3618**  
**W3918**  
**W4218**  
**W4818**

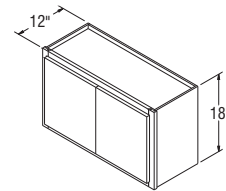

**W2718B**  
**W3018B**  
**W3318B**  
**W3618B**

\*Specify L or R on all single door Arch styles.

## Wall Cabinets, 18" High, 15" Deep

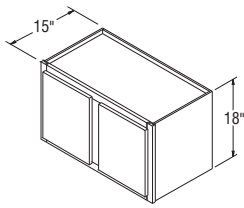

**W301815**  
**W361815**  
**W391815**

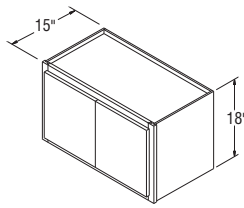

**W301815B**  
**W361815B**

### NOTES ✓

- ▶ Shelves not included.
- ▶ Cabinets use standard natural maple interior, excluding white which has a white interior.
- ▶ When varying heights, make sure to also vary depths to allow moulding to lie against adjacent side of cabinet.

### DESIGN SOLUTIONS

- ▶ Apply an End Panel Skin to create a flush end on the side of a Wall cabinet if installed at the end of a run for ease of Moulding installation.

## Wall Cabinets, 21" High, 12" Deep

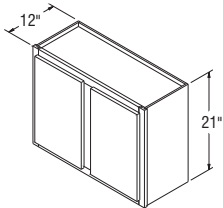

**W3021**  
**W3321**  
**W3621**  
**W3921**

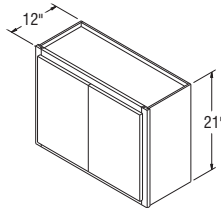

**W3021B**  
**W3321B**  
**W3621B**

### NOTES ✓

- ▶ Shelves not included.
- ▶ Cabinets use standard natural maple interior, excluding white which has a white interior.

### DESIGN SOLUTIONS

- ▶ Apply an End Panel Skin to create a flush end on the side of a Wall cabinet if installed at the end of a run for ease of Moulding installation.

## Wall Cabinets, 21" High, 15" Deep

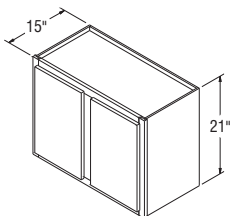

**W302115**  
**W362115**

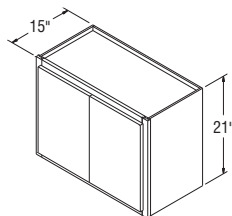

**W302115B**  
**W362115B**

### NOTES ✓

- ▶ Shelves not included.
- ▶ Cabinets use standard natural maple interior, excluding white which has a white interior.
- ▶ When varying heights, make sure to also vary depths to allow moulding to lie against adjacent side of cabinet.

### DESIGN SOLUTIONS

- ▶ Apply an End Panel Skin to create a flush end on the side of a Wall cabinet if installed at the end of a run for ease of Moulding installation.

Wall Cabinets, 24" High, 12" Deep

NOTES ✓

- ▶ Center shelf support clip included on Wall Double Door cabinets with center mullion.
- ▶ One adjustable shelf.
- ▶ Cabinets use standard natural maple interior, excluding white which has a white interior.

DESIGN SOLUTIONS

- ▶ Apply an End Panel Skin to create a flush end on the side of a Wall cabinet if installed at the end of a run for ease of Moulding installation.

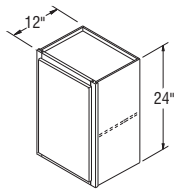

**W1524\***  
**W1824\***  
**W2124\***  
**W2424\***

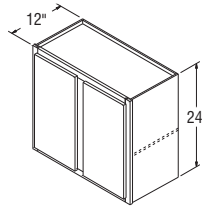

**W2724**  
**W3024**  
**W3324**  
**W3624**  
**W3924**  
**W4224**  
**W4824**

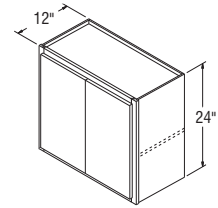

**W2724B**  
**W3024B**  
**W3324B**  
**W3624B**

\*Specify L or R on all single door Arch styles.

Wall Cabinets, 24" High, 15" Deep

NOTES ✓

- ▶ Center shelf support clip included on Wall Double Door cabinets with center mullion.
- ▶ One adjustable shelf.
- ▶ Cabinets use standard natural maple interior, excluding white which has a white interior.
- ▶ When varying heights, make sure to also vary depths to allow moulding to lie against adjacent side of cabinet.

DESIGN SOLUTIONS

- ▶ Apply an End Panel Skin to create a flush end on the side of a Wall cabinet if installed at the end of a run for ease of Moulding installation.

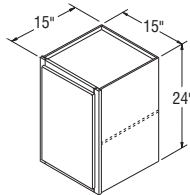

**W152415\***

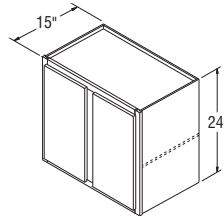

**W302415**  
**W362415**

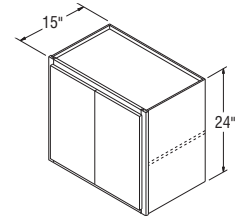

**W302415B**  
**W362415B**

\*Specify L or R on all single door Arch styles.

Wall Cabinets, 27" High, 12" Deep

NOTES ✓

- ▶ One adjustable shelf.
- ▶ Cabinets use standard natural maple interior, excluding white which has a white interior.

DESIGN SOLUTIONS

- ▶ Apply an End Panel Skin to create a flush end on the side of a Wall cabinet if installed at the end of a run for ease of Moulding installation.

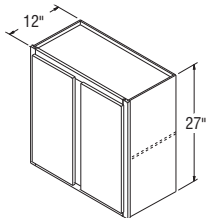

**W3027**

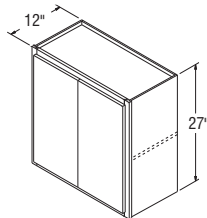

**W3027B**

## Wall Cabinets, 30" High, 12" Deep

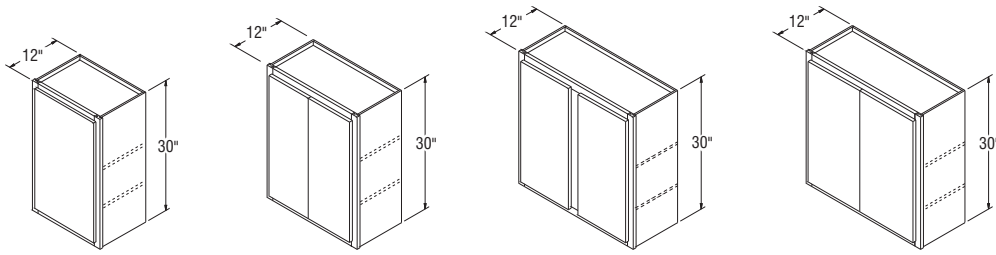

W0930  
W1230\*  
W1530\*  
W1830\*  
W2130\*  
W2430\*

W2430DD

W2730  
W3030  
W3330  
W3630  
W3930  
W4230  
W4530  
W4830

W2730B  
W3030B  
W3330B  
W3630B

\*Specify L or R on all single door Arch styles.

### NOTES ✓

- ▶ Center shelf support clip included on Wall Double Door cabinets with center mullion
- ▶ Two adjustable shelves.
- ▶ Cabinets use standard natural maple interior, excluding white which has a white interior.
- ▶ Nantucket and Grayson W0930 doors utilize recessed center panels.
- ▶ All W0930 cabinets have square doors.

### DESIGN SOLUTIONS

- ▶ Apply an End Panel Skin to create a flush end on the side of a Wall cabinet if installed at the end of a run for ease of Moulding installation.

## Wall Cabinets, 30" High, 15" Deep

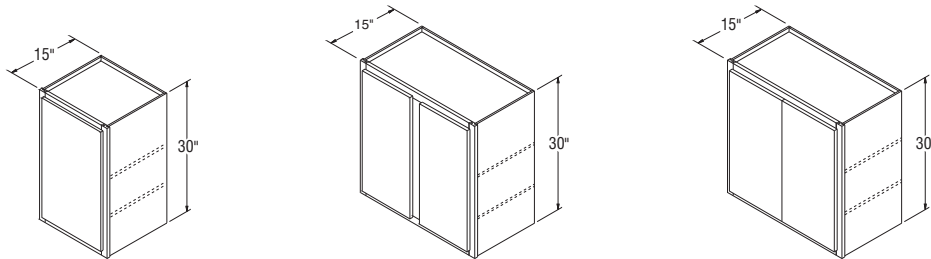

W153015\*  
W183015\*  
W213015\* *New*  
W243015\*

W273015 *New*  
W303015  
W333015 *New*  
W363015  
W393015 *New*  
W423015 *New*  
W453015 *New*

W273015B *New*  
W303015B  
W333015B *New*  
W363015B

\*Specify L or R on all single door Arch styles.

### NOTES ✓

- ▶ Center shelf support clip included on Wall Double Door cabinets with center mullion.
- ▶ Two adjustable shelves.
- ▶ Cabinets use standard natural maple interior, excluding white which has a white interior.
- ▶ When varying heights, make sure to also vary depths to allow moulding to lie against adjacent side of cabinet.

### DESIGN SOLUTIONS

- ▶ Apply an End Panel Skin to create a flush end on the side of a Wall cabinet if installed at the end of a run for ease of Moulding installation.

## Wall Cabinets, 36" High, 12" Deep

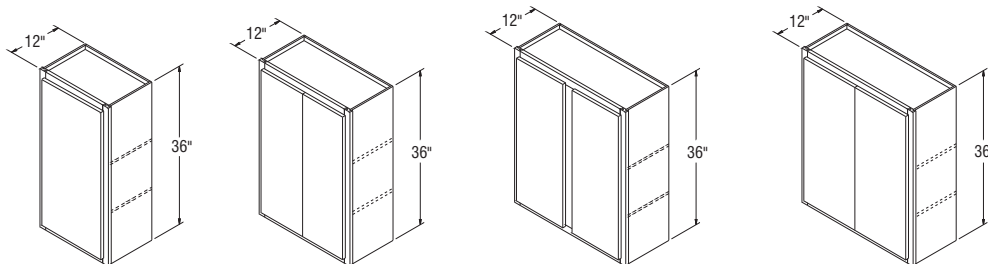

W0936  
W1236\*  
W1536\*  
W1836\*  
W2136\*  
W2436\*

W2436DD

W2736  
W3036  
W3336  
W3636  
W3936  
W4236  
W4536  
W4836

W2736B  
W3036B  
W3336B  
W3636B

\*Specify L or R on all single door Arch styles.

### NOTES ✓

- ▶ Center shelf support clip included on Wall Double Door cabinets with center mullion.
- ▶ Two adjustable shelves.
- ▶ Cabinets use standard natural maple interior, excluding white which has a white interior.
- ▶ Nantucket and Grayson W0936 doors utilize recessed center panels.
- ▶ All W0936 cabinets have square doors.

### DESIGN SOLUTIONS

- ▶ Apply an End Panel Skin to create a flush end on the side of a Wall cabinet if installed at the end of a run for ease of Moulding installation.

Wall Cabinets, 36" High, 15" Deep

NOTES ✓

- ▶ Center shelf support clip included on Wall Double Door cabinets with center mullion.
- ▶ Two adjustable shelves.
- ▶ Cabinets use standard natural maple interior, excluding white which has a white interior.
- ▶ When varying heights, make sure to also vary depths to allow moulding to lie against adjacent side of cabinet.

DESIGN SOLUTIONS

- ▶ Apply an End Panel Skin to create a flush end on the side of a Wall cabinet if installed at the end of a run for ease of Moulding installation.

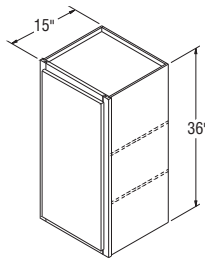

**W153615\***  
**W183615\***  
**W213615\* New**  
**W243615\***

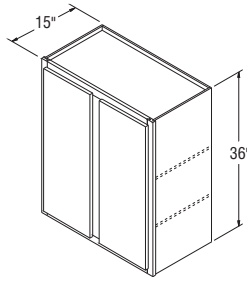

**W273615 New**  
**W303615**  
**W333615 New**  
**W363615**

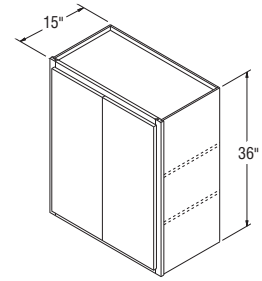

**W273615B New**  
**W303615B**  
**W333615B New**  
**W363615B**

\*Specify L or R on all single door Arch styles.

Wall Cabinets, 42" High, 12" Deep

NOTES ✓

- ▶ Center shelf support clip included on Wall Double Door cabinets with center mullion.
- ▶ Three adjustable shelves.
- ▶ Cabinets use standard natural maple interior, excluding white which has a white interior.
- ▶ All W0942 cabinets have square doors.
- ▶ Nantucket and Grayson W0942 doors utilize recessed center panels.

DESIGN SOLUTIONS

- ▶ Apply an End Panel Skin to create a flush end on the side of a Wall cabinet if installed at the end of a run for ease of Moulding installation.

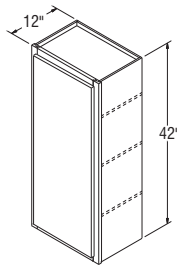

**W0942**  
**W1242\***  
**W1542\***  
**W1842\***  
**W2142\***  
**W2442\***

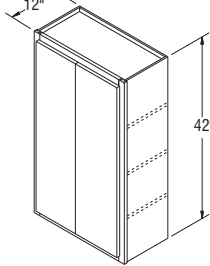

**W2442DD**

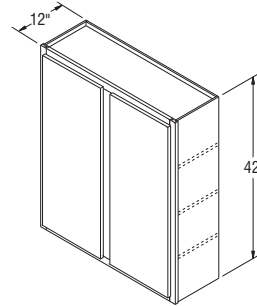

**W2742**  
**W3042**  
**W3342\***  
**W3642**  
**W3942**  
**W4242**  
**W4542**  
**W4842**

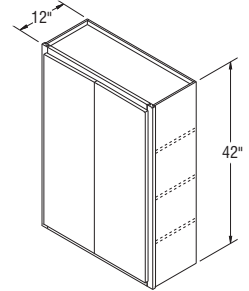

**W2742B**  
**W3042B**  
**W3342B**  
**W3642B**

\*Specify L or R on all single door Arch styles.

## Wall Cabinets, 42" High, 15" Deep

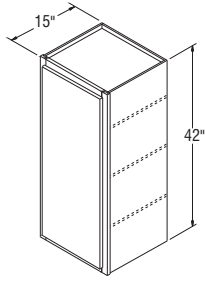

**W154215\***

**W184215\***

**W214215\* *New***

**W244215\***

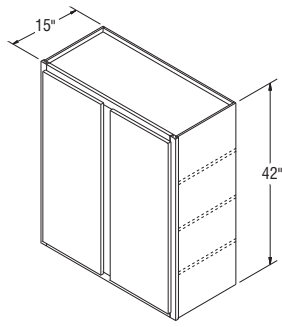

**W274215 *New***

**W304215**

**W334215 *New***

**W364215**

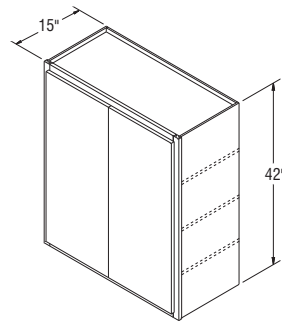

**W274215B *New***

**W304215B**

**W334215B *New***

**W364215B**

\*Specify L or R on all single door Arch styles.

### NOTES ✓

- ▶ Center shelf support clip included on Wall Double Door cabinets with center mullion.
- ▶ Three adjustable shelves.
- ▶ Cabinets use standard natural maple interior, excluding white which has a white interior.
- ▶ When varying heights, make sure to also vary depths to allow moulding to lie against adjacent side of cabinet.

### DESIGN SOLUTIONS

- ▶ Apply an End Panel Skin to create a flush end on the side of a Wall cabinet if installed at the end of a run for ease of Moulding installation.

## Wall Open Cabinets, 12" High, 12" Deep *New*

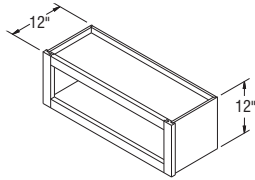

**WOL3012**

**WOL3312**

**WOL3612**

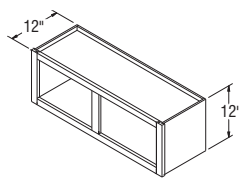

**WOL3912**

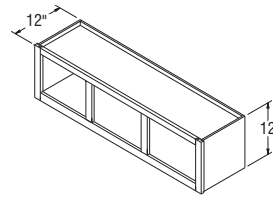

**WOL4212**

**WOL4812**

### NOTES ✓

- ▶ Cabinets include matching Aristex® interior.
- ▶ Cabinets use standard natural maple interior, excluding white which has a white interior.

### DESIGN SOLUTIONS

- ▶ Apply an End Panel Skin to create a flush end on the side of a Wall cabinet if installed at the end of a run for ease of Moulding installation.

## Wall Open Cabinets, 14" High, 12" Deep *New*

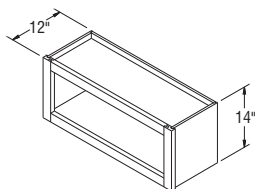

**WOL3014**

**WOL3314**

**WOL3614**

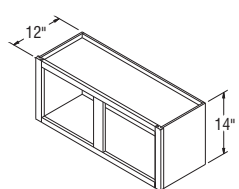

**WOL3914**

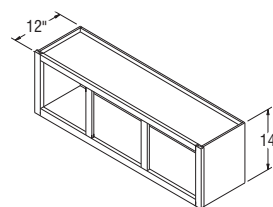

**WOL4214**

**WOL4814**

### NOTES ✓

- ▶ Cabinets include matching Aristex® interior.
- ▶ Cabinets use standard natural maple interior, excluding white which has a white interior.

### DESIGN SOLUTIONS

- ▶ Apply an End Panel Skin to create a flush end on the side of a Wall cabinet if installed at the end of a run for ease of Moulding installation.

**NOTES** ✓

- ▶ Cabinets include matching Aristex® interior.
- ▶ Cabinets use standard natural maple interior, excluding white which has a white interior.

**DESIGN SOLUTIONS**

- ▶ Apply an End Panel Skin to create a flush end on the side of a Wall cabinet if installed at the end of a run for ease of Moulding installation.

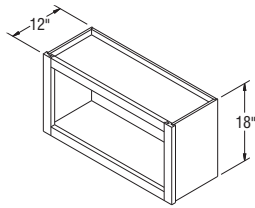
**Wall Open Cabinets, 18" High, 12" Deep *New***

**WOL2418**  
**WOL2718**  
**WOL3018**  
**WOL3318**  
**WOL3618**

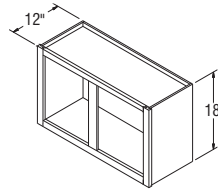

**WOL3918**  
**WOL4218**

**NOTES** ✓

- ▶ Cabinets include matching Aristex® interior.
- ▶ Cabinets use standard natural maple interior, excluding white which has a white interior.

**DESIGN SOLUTIONS**

- ▶ Apply an End Panel Skin to create a flush end on the side of a Wall cabinet if installed at the end of a run for ease of Moulding installation.

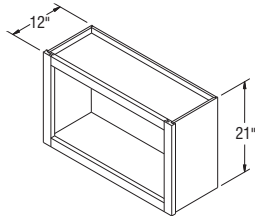
**Wall Open Cabinets, 21" High, 12" Deep**

**WOL3021**  
**WOL3621**

**NOTES** ✓

- ▶ Cabinets include matching Aristex® interior.
- ▶ Butt doors only can be added in the field, if desired. See page 17 for available styles.
- ▶ When varying heights, make sure to also vary depths to allow moulding to lie against adjacent side of cabinet.

**DESIGN SOLUTIONS**

- ▶ Apply an End Panel Skin to create a flush end on the side of a Wall cabinet if installed at the end of a run for ease of Moulding installation.

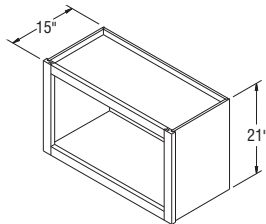
**Wall Open Cabinets, 21" High, 15" Deep**

**WOL302115**  
**WOL362115**

## Wall Open Cabinets, 24" High, 12" Deep

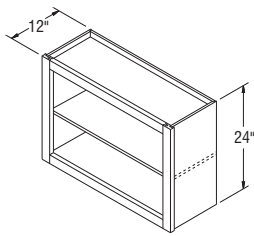

**WOL2424** *New*  
**WOL2724** *New*  
**WOL3024**  
**WOL3324** *New*  
**WOL3624**

### NOTES ✓

- ▶ One adjustable ¾" thick matching Aristex® shelf.
- ▶ Cabinets include matching Aristex® interior.

### DESIGN SOLUTIONS

- ▶ Apply an End Panel Skin to create a flush end on the side of a Wall cabinet if installed at the end of a run for ease of Moulding installation.

## Wall Open Cabinets, 24" High, 15" Deep

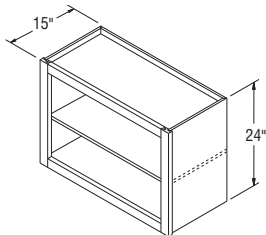

**WOL302415**  
**WOL362415**

### NOTES ✓

- ▶ One adjustable ¾" thick matching Aristex® shelf.
- ▶ Cabinets include matching Aristex® interior.
- ▶ Butt doors only can be added in the field, if desired. See page 17 for available styles.
- ▶ When varying heights, make sure to also vary depths to allow moulding to lie against adjacent side of cabinet.

### DESIGN SOLUTIONS

- ▶ Apply an End Panel Skin to create a flush end on the side of a Wall cabinet if installed at the end of a run for ease of Moulding installation.

## Wall Open Cabinets, 30" High, 12" Deep

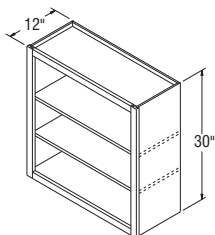

**WOL1230** *New*  
**WOL1530**  
**WOL1830**  
**WOL2130**  
**WOL2430**  
**WOL2730** *New*  
**WOL3030**  
**WOL3330** *New*  
**WOL3630**

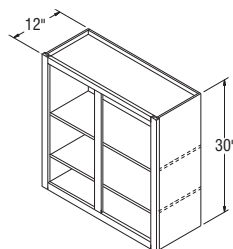

**WOL3930** *New*  
**WOL4230** *New*  
**WOL4530** *New*  
**WOL4830** *New*

### NOTES ✓

- ▶ Two adjustable ¾" thick matching Aristex® shelves.
- ▶ Cabinets include matching Aristex® interior.
- ▶ Doors can be added in the field, if desired. See page 17 for available styles.

### DESIGN SOLUTIONS

- ▶ Apply an End Panel Skin to create a flush end on the side of a Wall cabinet if installed at the end of a run for ease of Moulding installation.

Wall Open Cabinets, 30" High, 15" Deep

NOTES ✓

- ▶ Two adjustable 3/4" thick matching Aristex® shelves.
- ▶ Cabinets include matching Aristex® interior.
- ▶ Doors can be added in the field, if desired. See page 17 for available styles.
- ▶ When varying heights, make sure to also vary depths to allow moulding to lie against adjacent side of cabinet.

DESIGN SOLUTIONS

- ▶ Apply an End Panel Skin to create a flush end on the side of a Wall cabinet if installed at the end of a run for ease of Moulding installation.

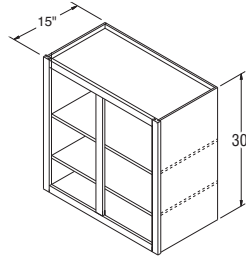
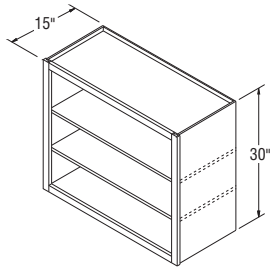

**WOL213015** *New*  
**WOL243015** *New*  
**WOL273015** *New*  
**WOL303015**  
**WOL333015** *New*  
**WOL363015**

**WOL393015** *New*  
**WOL423015** *New*  
**WOL453015** *New*

Wall Open Cabinets, 36" High, 12" Deep

NOTES ✓

- ▶ Two adjustable 3/4" thick matching Aristex® shelves.
- ▶ Cabinets include matching Aristex® interior.
- ▶ Doors can be added in the field, if desired. See page 17 for available styles.

DESIGN SOLUTIONS

- ▶ Apply an End Panel Skin to create a flush end on the side of a Wall cabinet if installed at the end of a run for ease of Moulding installation.

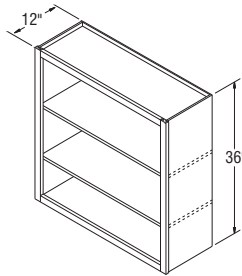

**WOL1236** *New*  
**WOL1536**  
**WOL1836**  
**WOL2136**  
**WOL2436**

**WOL2736** *New*  
**WOL3036**  
**WOL3336** *New*  
**WOL3636**

Wall Open Cabinets, 36" High, 15" Deep

NOTES ✓

- ▶ Two adjustable 3/4" thick matching Aristex® shelves.
- ▶ Cabinets include matching Aristex® interior.
- ▶ Doors can be added in the field, if desired. See page 17 for available styles.
- ▶ When varying heights, make sure to also vary depths to allow moulding to lie against adjacent side of cabinet.

DESIGN SOLUTIONS

- ▶ Apply an End Panel Skin to create a flush end on the side of a Wall cabinet if installed at the end of a run for ease of Moulding installation.

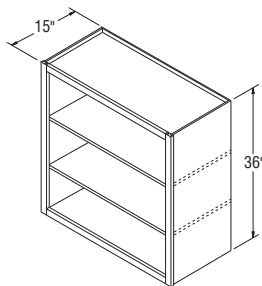

**WOL153615** *New*  
**WOL183615** *New*  
**WOL213615** *New*  
**WOL243615** *New*  
**WOL273615** *New*  
**WOL303615**  
**WOL333615** *New*  
**WOL363615**

## Wall Open Cabinets, 42" High, 12" Deep

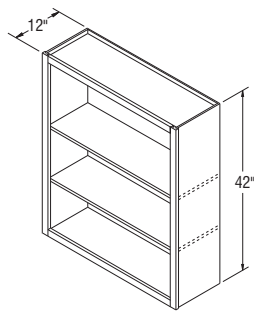

**WOL1242** *New*

**WOL1542**

**WOL1842**

**WOL2142**

**WOL2442**

**WOL2742** *New*

**WOL3042**

**WOL3342** *New*

**WOL3642**

### NOTES ✓

- ▶ Two adjustable ¾" thick matching Aristex® shelves.
- ▶ Cabinets include matching Aristex® interior.
- ▶ Doors can be added in the field, if desired. See page 17 for available styles.

### DESIGN SOLUTIONS

- ▶ Apply an End Panel Skin to create a flush end on the side of a Wall cabinet if installed at the end of a run for ease of Moulding installation.

## Wall Open Cabinets, 42" High, 15" Deep

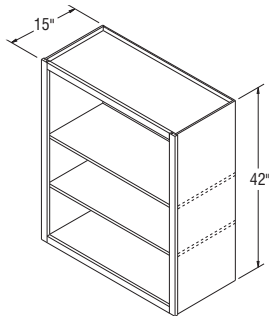

**WOL154215** *New*

**WOL184215** *New*

**WOL214215** *New*

**WOL244215** *New*

**WOL274215** *New*

**WOL304215**

**WOL334215** *New*

**WOL364215**

### NOTES ✓

- ▶ Two adjustable ¾" thick matching Aristex® shelves.
- ▶ Cabinets include matching Aristex® shelves.
- ▶ When varying heights, make sure to also vary depths to allow moulding to lie against adjacent side of cabinet.
- ▶ Doors can be added in the field, if desired. See page 17 for available styles.

### DESIGN SOLUTIONS

- ▶ Apply an End Panel Skin to create a flush end on the side of a Wall cabinet if installed at the end of a run for ease of Moulding installation.

## Wall Cabinets with Mullion Doors, 18" High, 12" Deep *New*

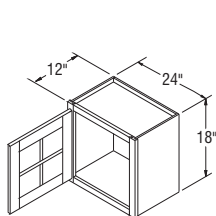

**WMD2418\***

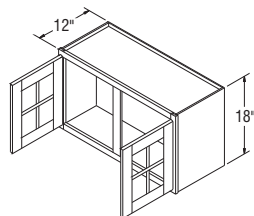

**WMD2718**

**WMD3018**

**WMD3318**

**WMD3618**

**WMD3918**

**WMD4218**

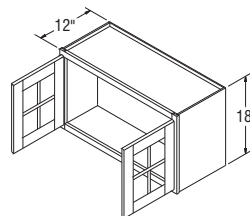

**WMD2718B**

**WMD3018B**

**WMD3318B**

**WMD3618B**

### NOTES ✓

- ▶ Cabinets include installed, clear tempered glass, and matching Aristex® interior.
- ▶ See page 24 for Standard and Shaker Mullion Door style availability and grid configurations.
- ▶ Mullion Door cabinets are not available in Ellsworth, Teagan, or VanWyke.

### DESIGN SOLUTIONS

- ▶ Apply an End Panel Skin to create a flush end on the side of a Wall cabinet if installed at the end of a run for ease of Moulding installation.
- ▶ For complementary Wall Mullion Door cabinets in Teagan, order as Winstead Maple, as Teagan features a slab door design.

\*Specify L or R on all single door Arch styles.

**NOTES** ✓

- ▶ Cabinets include installed, clear tempered glass, and matching Aristex® interior.
- ▶ See page 24 for Standard and Shaker Mullion Door style availability and grid configurations.
- ▶ Mullion Door cabinets are not available in Ellsworth, Teagan, or VanWyke.

**DESIGN SOLUTIONS**

- ▶ Apply an End Panel Skin to create a flush end on the side of a Wall cabinet if installed at the end of a run for ease of Moulding installation.
- ▶ For complementary Wall Mullion Door cabinets in Teagan, order as Winstead Maple, as Teagan features a slab door design.

Wall Cabinets with Mullion Doors, 21" High, 12" Deep

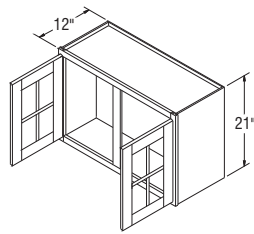

**WMD3021**  
**WMD3621**

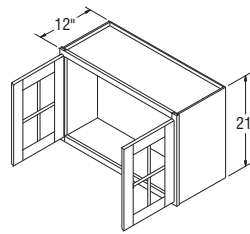

**WMD3021B**  
**WMD3621B**

**NOTES** ✓

- ▶ Cabinets include installed, clear tempered glass, and matching Aristex® interior.
- ▶ See page 24 for Standard and Shaker Mullion Door style availability and grid configurations.
- ▶ Mullion Door cabinets are not available in Ellsworth, Teagan, or VanWyke.

**DESIGN SOLUTIONS**

- ▶ Apply an End Panel Skin to create a flush end on the side of a Wall cabinet if installed at the end of a run for ease of Moulding installation.
- ▶ For complementary Wall Mullion Door cabinets in Teagan, order as Winstead Maple, as Teagan features a slab door design.

Wall Cabinets with Mullion Doors, 21" High, 15" Deep

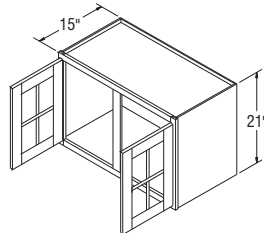

**WMD302115**  
**WMD362115**

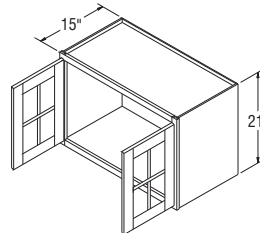

**WMD302115B**  
**WMD362115B**

**NOTES** ✓

- ▶ One adjustable 3/4" thick matching Aristex® shelf aligns with door mullions on Standard mullions, but does not align on Shaker mullions.
- ▶ Cabinets include installed, clear tempered glass, and matching Aristex® interior.
- ▶ See page 24 for Standard and Shaker Mullion Door style availability and grid configurations.
- ▶ Mullion Door cabinets are not available in Ellsworth, Teagan, or VanWyke.

**DESIGN SOLUTIONS**

- ▶ Apply an End Panel Skin to create a flush end on the side of a Wall cabinet if installed at the end of a run for ease of Moulding installation.
- ▶ For complementary Wall Mullion Door cabinets in Teagan, order as Winstead Maple, as Teagan features a slab door design.

Wall Cabinets with Mullion Doors, 24" High, 12" Deep

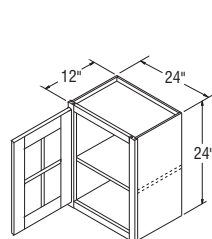

**WMD2424\* New**

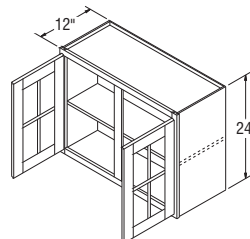

**WMD2724 New**  
**WMD3024**  
**WMD3324 New**  
**WMD3624**

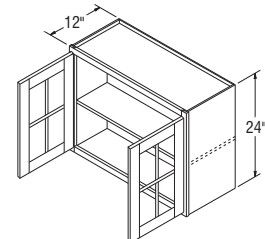

**WMD2724B New**  
**WMD3024B**  
**WMD3324B New**  
**WMD3624B**

\*Specify L or R on all single door Arch styles.

## Wall Cabinets with Mullion Doors, 24" High, 15" Deep

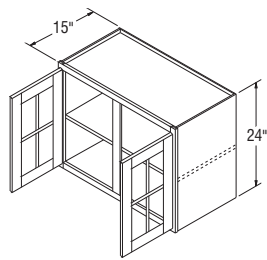

**WMD302415**  
**WMD362415**

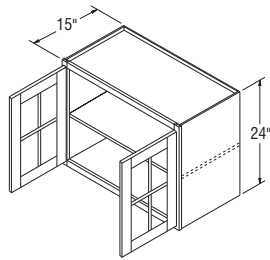

**WMD302415B**  
**WMD362415B**

### NOTES ✓

- ▶ One adjustable 3/4" thick matching Aristex® shelf aligns with door mullions on Standard mullions, but does not align on Shaker mullions.
- ▶ Cabinets include installed, clear tempered glass, and matching Aristex® interior.
- ▶ See page 24 for Standard and Shaker Mullion Door style availability and grid configurations.
- ▶ Mullion Door cabinets are not available in Ellsworth, Teagan, or VanWyke.

### DESIGN SOLUTIONS

- ▶ Apply an End Panel Skin to create a flush end on the side of a Wall cabinet if installed at the end of a run for ease of Moulding installation.
- ▶ For complementary Wall Mullion Door cabinets in Teagan, order as Winstead Maple, as Teagan features a slab door design.

## Wall Cabinets with Mullion Doors, 30" High, 12" Deep

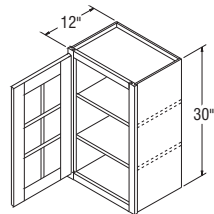

**WMD1530\***  
**WMD1830\***  
**WMD2130\***  
**WMD2430\***

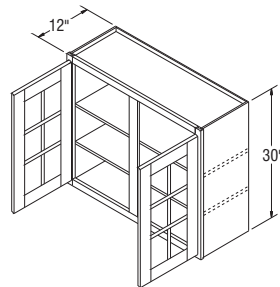

**WMD2730** *New*  
**WMD3030**  
**WMD3330** *New*  
**WMD3630**

**WMD3930** *New*  
**WMD4230** *New*  
**WMD4530** *New*  
**WMD4830** *New*

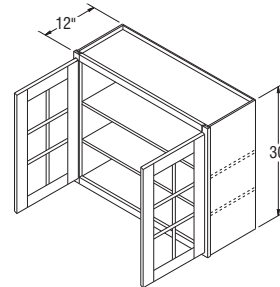

**WMD2730B** *New*  
**WMD3030B**  
**WMD3330B** *New*  
**WMD3630B**

### NOTES ✓

- ▶ Two adjustable 3/4" thick matching Aristex® shelves align with door mullions on Standard mullions, but do not align on Shaker mullions.
- ▶ Cabinets include installed, clear tempered glass and matching Aristex® interior.
- ▶ See page 24 for Standard and Shaker Mullion Door style availability and grid configurations.
- ▶ Mullion Door cabinets are not available in Ellsworth, Teagan, or VanWyke.

### DESIGN SOLUTIONS

- ▶ Apply an End Panel Skin to create a flush end on the side of a Wall cabinet if installed at the end of a run for ease of Moulding installation.
- ▶ For complementary Wall Mullion Door cabinets in Teagan, order as Winstead Maple, as Teagan features a slab door design.

\*Specify L or R on all single door Arch styles.

## Wall Cabinets with Mullion Doors, 30" High, 15" Deep

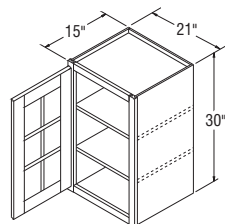

**WMD213015\*** *New*  
**WMD243015\*** *New*

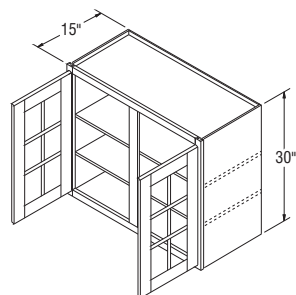

**WMD273015** *New*  
**WMD303015**  
**WMD333015** *New*  
**WMD363015**  
**WMD393015** *New*  
**WMD423015** *New*  
**WMD453015** *New*

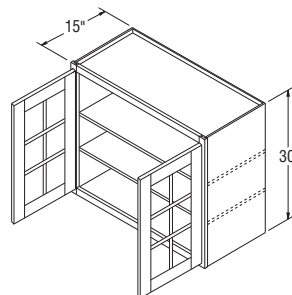

**WMD273015B** *New*  
**WMD303015B**  
**WMD333015B** *New*  
**WMD363015B**

### NOTES ✓

- ▶ Two adjustable 3/4" thick matching Aristex® shelves align with door mullions on Standard mullions, but do not align on Shaker mullions.
- ▶ Cabinets include installed, clear tempered glass, and matching Aristex® interior.
- ▶ See page 24 for Standard and Shaker Mullion Door style availability and grid configurations.
- ▶ Mullion Door cabinets are not available in Ellsworth, Teagan, or VanWyke.

### DESIGN SOLUTIONS

- ▶ Apply an End Panel Skin to create a flush end on the side of a Wall cabinet if installed at the end of a run for ease of Moulding installation.
- ▶ For complementary Wall Mullion Door cabinets in Teagan, order as Winstead Maple, as Teagan features a slab door design.

\*Specify L or R on all single door Arch styles.

NOTES ✓

- ▶ Two adjustable ¾" thick matching Aristex® shelves align with door mullions on Standard mullions, but do not align on Shaker mullions.
- ▶ Cabinets include installed, clear tempered glass and matching Aristex® interior.
- ▶ See page 24 for Standard and Shaker Mullion Door style availability and grid configurations.
- ▶ Mullion Door cabinets are not available in Ellsworth, Teagan, or VanWyke.

DESIGN SOLUTIONS

- ▶ Apply an End Panel Skin to create a flush end on the side of a Wall cabinet if installed at the end of a run for ease of Moulding installation.
- ▶ For complementary Wall Mullion Door cabinets in Teagan, order as Winstead Maple, as Teagan features a slab door design.

Wall Cabinets with Mullion Doors, 36" High, 12" Deep

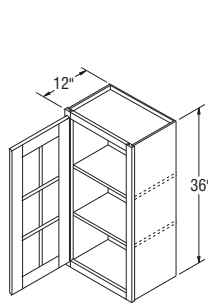

**WMD1536\***  
**WMD1836\***  
**WMD2136\***  
**WMD2436\***

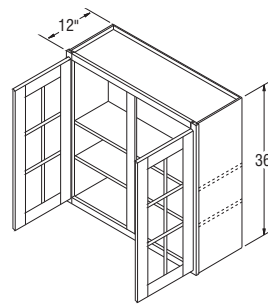

**WMD2736 *New***  
**WMD3036**  
**WMD3336 *New***  
**WMD3636**

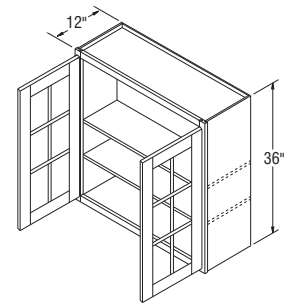

**WMD2736B *New***  
**WMD3036B**  
**WMD3336B *New***  
**WMD3636B**

\*Specify L or R on all single door Arch styles.

NOTES ✓

- ▶ Two adjustable ¾" thick matching Aristex® shelves align with door mullions on Standard mullions, but do not align on Shaker mullions.
- ▶ Cabinets include installed, clear tempered glass, and matching Aristex® interior.
- ▶ See page 24 for Standard and Shaker Mullion Door style availability and grid configurations.
- ▶ Mullion Door cabinets are not available in Ellsworth, Teagan, or VanWyke.

DESIGN SOLUTIONS

- ▶ Apply an End Panel Skin to create a flush end on the side of a Wall cabinet if installed at the end of a run for ease of Moulding installation.
- ▶ For complementary Wall Mullion Door cabinets in Teagan, order as Winstead Maple, as Teagan features a slab door design.

Wall Cabinets with Mullion Doors, 36" High, 15" Deep

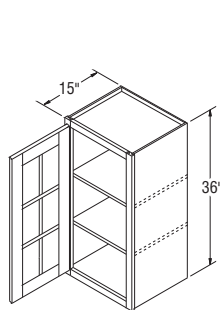

**WMD153615\* *New***  
**WMD183615\* *New***  
**WMD213615\* *New***  
**WMD243615\* *New***

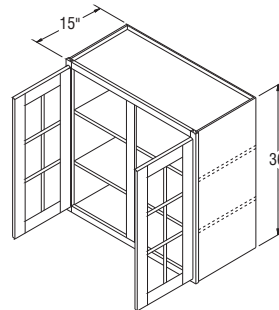

**WMD273615 *New***  
**WMD303615**  
**WMD333615 *New***  
**WMD363615**

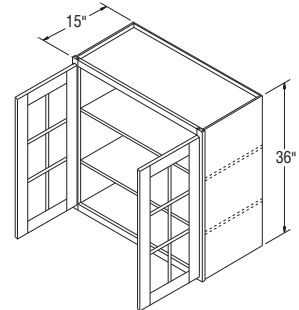

**WMD273615B *New***  
**WMD303615B**  
**WMD333615B *New***  
**WMD363615B**

\*Specify L or R on all single door Arch styles.

## Wall Cabinets with Mullion Doors, 42" High, 12" Deep

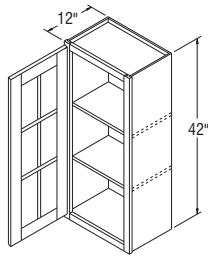

**WMD1542\***  
**WMD1842\***  
**WMD2142\***  
**WMD2442\***

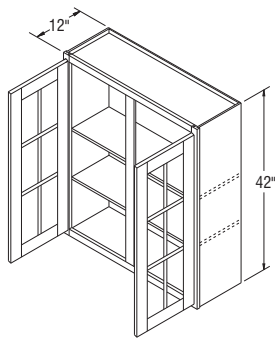

**WMD2742** *New*  
**WMD3042**  
**WMD3342** *New*  
**WMD3642**

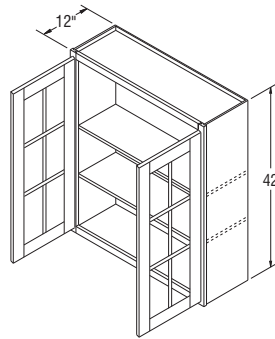

**WMD2742B** *New*  
**WMD3042B**  
**WMD3342B** *New*  
**WMD3642B**

\*Specify L or R on all single door Arch styles.

### NOTES ✓

- ▶ Two adjustable 3/4" thick matching Aristex® shelves align with door mullions on Standard mullions, but do not align on Shaker mullions.
- ▶ Cabinets include installed, clear tempered glass and matching Aristex® interior.
- ▶ See page 24 for Standard and Shaker Mullion Door style availability and grid configurations.
- ▶ Mullion Door cabinets are not available in Ellsworth, Teagan, or VanWyke.

### DESIGN SOLUTIONS

- ▶ Apply an End Panel Skin to create a flush end on the side of a Wall cabinet if installed at the end of a run for ease of Moulding installation.
- ▶ For complementary Wall Mullion Door cabinets in Teagan, order as Winstead Maple, as Teagan features a slab door design.

## Wall Cabinets with Mullion Doors, 42" High, 15" Deep

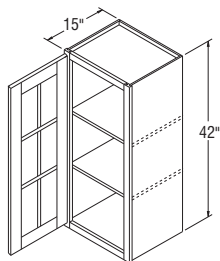

**WMD154215\*** *New*  
**WMD184215\*** *New*  
**WMD214215\*** *New*  
**WMD244215\*** *New*

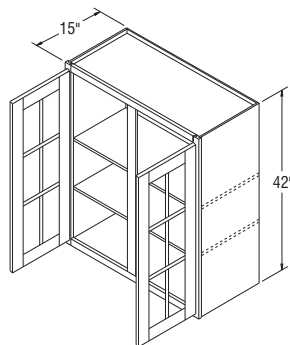

**WMD274215** *New*  
**WMD304215**  
**WMD334215** *New*  
**WMD364215**

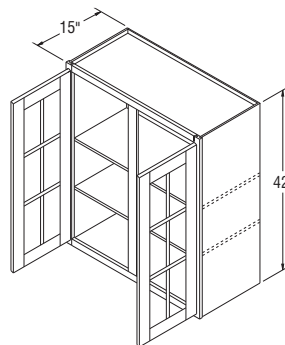

**WMD274215B** *New*  
**WMD304215B**  
**WMD334215B** *New*  
**WMD364215B**

\*Specify L or R on all single door Arch styles.

### NOTES ✓

- ▶ Two adjustable 3/4" thick matching Aristex® shelves align with door mullions on Standard mullions, but do not align on Shaker mullions.
- ▶ Cabinets include installed, clear tempered glass, and matching Aristex® interior.
- ▶ See page 24 for Standard and Shaker Mullion Door style availability and grid configurations.
- ▶ Mullion Door cabinets are not available in Ellsworth, Teagan, or VanWyke.

### DESIGN SOLUTIONS

- ▶ Apply an End Panel Skin to create a flush end on the side of a Wall cabinet if installed at the end of a run for ease of Moulding installation.
- ▶ For complementary Wall Mullion Door cabinets in Teagan, order as Winstead Maple, as Teagan features a slab door design.

Wall Cabinets with Doors Prepped for Glass, 12" High, 12" Deep *New*

NOTES ✓

- ▶ Cabinets include matching Aristex® interior.
- ▶ Wall Prepped for Glass cabinets are not available in Augusta, Nantucket, Teagan, or VanWyke.
- ▶ Center door on WPG4212 and WPG4812 will be hinged on the left.
- ▶ Doors Only for WPG cabinets can be ordered to meet the need for Doors Cut for Glass.

DESIGN SOLUTIONS

- ▶ Apply an End Panel Skin to create a flush end on the side of a Wall cabinet if installed at the end of a run for ease of Moulding installation.
- ▶ For complementary Wall Prepped for Glass cabinets in Teagan, order as Winstead Maple, as Teagan features a slab door design.

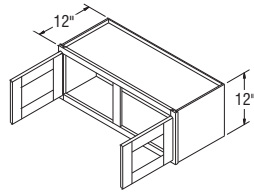

**WPG3012**  
**WPG3312**  
**WPG3612**  
**WPG3912**

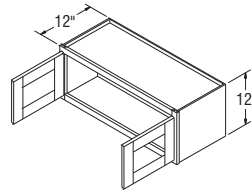

**WPG3012B**  
**WPG3312B**  
**WPG3612B**

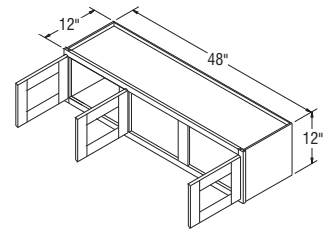

**WPG4212**

NOTES ✓

- ▶ Cabinets include matching Aristex® interior.
- ▶ Wall Prepped for Glass cabinets are not available in Augusta, Nantucket, Teagan, or VanWyke.
- ▶ Center door on WPG4214 and WPG4814 will be hinged on the left.
- ▶ Doors Only for WPG cabinets can be ordered to meet the need for Doors Cut for Glass.

DESIGN SOLUTIONS

- ▶ Apply an End Panel Skin to create a flush end on the side of a Wall cabinet if installed at the end of a run for ease of Moulding installation.
- ▶ For complementary Wall Prepped for Glass cabinets in Teagan, order as Winstead Maple, as Teagan features a slab door design.

Wall Cabinets with Doors Prepped for Glass, 14" High, 12" Deep *New*

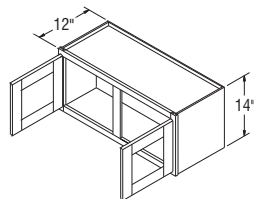

**WPG3014**  
**WPG3314**  
**WPG3614**  
**WPG3914**

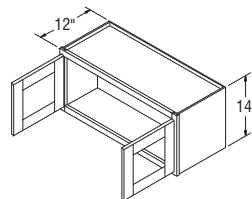

**WPG3014B**  
**WPG3314B**  
**WPG3614B**

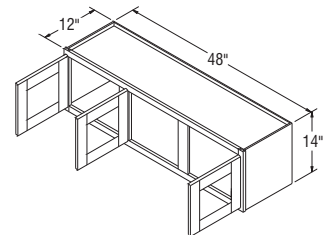

**WPG4214**  
**WPG4814**

NOTES ✓

- ▶ Cabinets include matching Aristex® interior.
- ▶ Wall Prepped for Glass cabinets are not available in Augusta, Nantucket, Teagan, or VanWyke.
- ▶ Doors Only for WPG cabinets can be ordered to meet the need for Doors Cut for Glass.

DESIGN SOLUTIONS

- ▶ Apply an End Panel Skin to create a flush end on the side of a Wall cabinet if installed at the end of a run for ease of Moulding installation.
- ▶ For complementary Wall Prepped for Glass cabinets in Teagan, order as Winstead Maple, as Teagan features a slab door design.

Wall Cabinets with Doors Prepped for Glass, 18" High, 12" Deep *New*

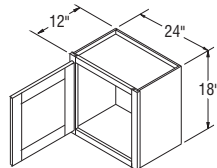

**WPG2418\***

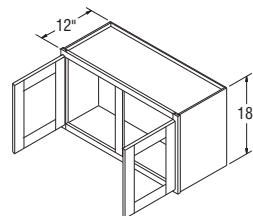

**WPG2718**  
**WPG3018**  
**WPG3318**  
**WPG3618**  
**WPG3918**  
**WPG4218**

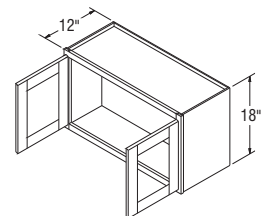

**WPG2718B**  
**WPG3018B**  
**WPG3318B**  
**WPG3618B**

\*Specify L or R on all single door Arch styles.

## Wall Cabinets with Doors Prepped for Glass, 21" High, 12" Deep

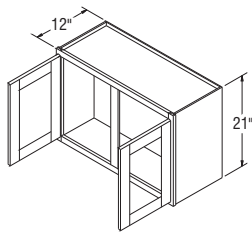

**WPG3021**  
**WPG3621**

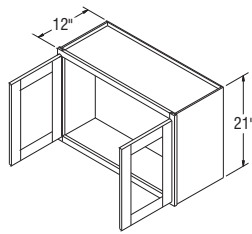

**WPG3021B**  
**WPG3621B**

### NOTES ✓

- ▶ Cabinets include matching Aristex® interior.
- ▶ Wall Prepped for Glass cabinets are not available in Augusta, Nantucket, Teagan, or VanWyke.
- ▶ Doors Only for WPG cabinets can be ordered to meet the need for Doors Cut for Glass.

### DESIGN SOLUTIONS

- ▶ Apply an End Panel Skin to create a flush end on the side of a Wall cabinet if installed at the end of a run for ease of Moulding installation.
- ▶ For complementary Wall Prepped for Glass cabinets in Teagan, order as Winstead Maple, as Teagan features a slab door design.

## Wall Cabinets with Doors Prepped for Glass, 21" High, 15" Deep

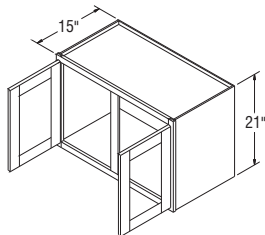

**WPG302115**  
**WPG362115**

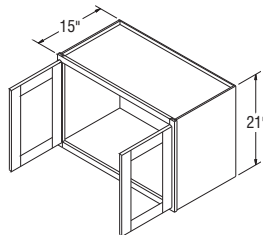

**WPG302115B**  
**WPG362115B**

### NOTES ✓

- ▶ Cabinets include matching Aristex® interior.
- ▶ Wall Prepped for Glass cabinets are not available in Augusta, Nantucket, Teagan, or VanWyke.
- ▶ Doors Only for WPG cabinets can be ordered to meet the need for Doors Cut for Glass.

### DESIGN SOLUTIONS

- ▶ Apply an End Panel Skin to create a flush end on the side of a Wall cabinet if installed at the end of a run for ease of Moulding installation.
- ▶ For complementary Wall Prepped for Glass cabinets in Teagan, order as Winstead Maple, as Teagan features a slab door design.

## Wall Cabinets with Doors Prepped for Glass, 24" High, 12" Deep

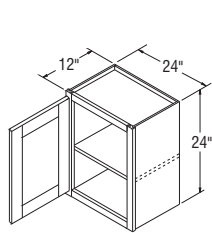

**WPG2424\*** *New*

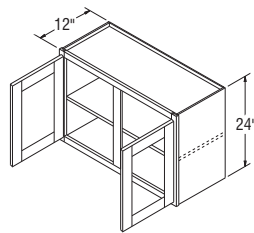

**WPG2724** *New*  
**WPG3024**  
**WPG3324** *New*  
**WPG3624**

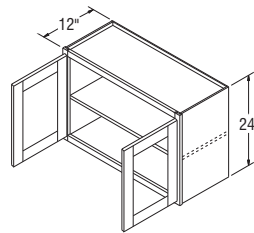

**WPG2724B** *New*  
**WPG3024B**  
**WPG3324B** *New*  
**WPG3624B**

### NOTES ✓

- ▶ Cabinets include matching Aristex® interior, one adjustable 3/4" thick matching Aristex® shelf, and clips to install glass (glass not included).
- ▶ Wall Prepped for Glass cabinets are not available in Augusta, Nantucket, Teagan, or VanWyke.
- ▶ Doors Only for WPG cabinets can be ordered to meet the need for Doors Cut for Glass.

### DESIGN SOLUTIONS

- ▶ Apply an End Panel Skin to create a flush end on the side of a Wall cabinet if installed at the end of a run for ease of Moulding installation.
- ▶ For complementary Wall Prepped for Glass cabinets in Teagan, order as Winstead Maple, as Teagan features a slab door design.

\*Specify L or R on all single door Arch styles.

Wall Cabinets with Doors Prepped for Glass, 24" High, 15" Deep

NOTES ✓

- ▶ Cabinets include matching Aristex® interior, two adjustable ¾" thick matching Aristex® shelves, and clips to install glass (glass not included).
- ▶ Wall Prepped for Glass cabinets are not available in Augusta, Nantucket, Teagan, or VanWyke.
- ▶ Doors Only for WPG cabinets can be ordered to meet the need for Doors Cut for Glass.

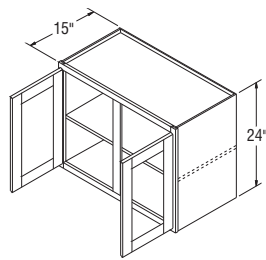

**WPG302415**  
**WPG362415**

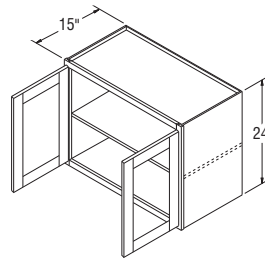

**WPG302415B**  
**WPG362415B**

DESIGN SOLUTIONS

- ▶ Apply an End Panel Skin to create a flush end on the side of a Wall cabinet if installed at the end of a run for ease of Moulding installation.
- ▶ For complementary Wall Prepped for Glass cabinets in Teagan, order as Winstead Maple, as Teagan features a slab door design.

NOTES ✓

Wall Cabinets with Doors Prepped for Glass, 30" High, 12" Deep

- ▶ Cabinets include matching Aristex® interior, two adjustable ¾" thick matching Aristex® shelves, and clips to install glass (glass not included).
- ▶ Wall Prepped for Glass cabinets are not available in Augusta, Nantucket, Teagan, or VanWyke.
- ▶ Doors Only for WPG cabinets can be ordered to meet the need for Doors Cut for Glass.

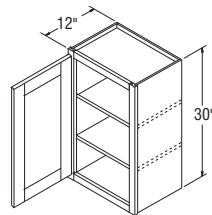

**WPG1230\* New**  
**WPG1530\***  
**WPG1830\***  
**WPG2130\***  
**WPG2430\***

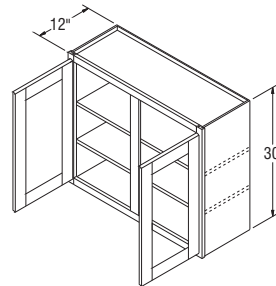

**WPG2730 New**  
**WPG3030**  
**WPG3330 New**  
**WPG3630**  
**WPG3930 New**  
**WPG4230 New**  
**WPG4530 New**  
**WPG4830 New**

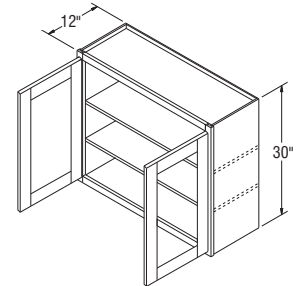

**WPG2730B New**  
**WPG3030B**  
**WPG3330B New**  
**WPG3630B**

DESIGN SOLUTIONS

- ▶ Apply an End Panel Skin to create a flush end on the side of a Wall cabinet if installed at the end of a run for ease of Moulding installation.
- ▶ For complementary Wall Prepped for Glass cabinets in Teagan, order as Winstead Maple, as Teagan features a slab door design.

\*Specify L or R on all single door Arch styles.

NOTES ✓

Wall Cabinets with Doors Prepped for Glass, 30" High, 15" Deep

- ▶ Cabinets include matching Aristex® interior, two adjustable ¾" thick matching Aristex® shelves, and clips to install glass (glass not included).
- ▶ Wall Prepped for Glass cabinets are not available in Augusta, Nantucket, Teagan, or VanWyke.
- ▶ Doors Only for WPG cabinets can be ordered to meet the need for Doors Cut for Glass.

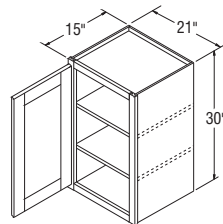

**WPG213015\* New**  
**WPG243015\* New**

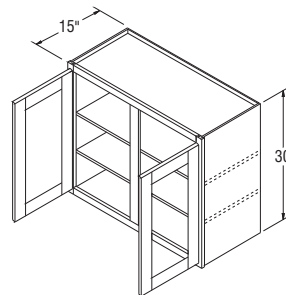

**WPG273015 New**  
**WPG303015**  
**WPG333015 New**  
**WPG363015**  
**WPG393015 New**  
**WPG423015 New**  
**WPG453015 New**

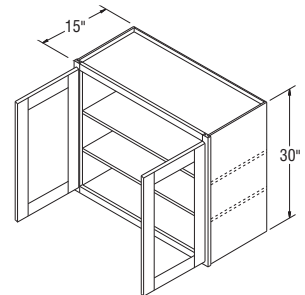

**WPG273015B New**  
**WPG303015B**  
**WPG333015 New**  
**WPG363015B**

DESIGN SOLUTIONS

- ▶ Apply an End Panel Skin to create a flush end on the side of a Wall cabinet if installed at the end of a run for ease of Moulding installation.
- ▶ For complementary Wall Prepped for Glass cabinets in Teagan, order as Winstead Maple, as Teagan features a slab door design.

\*Specify L or R on all single door Arch styles.

## Wall Cabinets with Doors Prepped for Glass, 36" High, 12" Deep

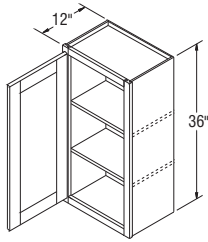

**WPG1236\*** *New*  
**WPG1536\***  
**WPG1836\***  
**WPG2136\***  
**WPG2436\***

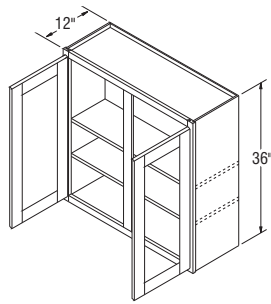

**WPG2436DD** *New*  
**WPG2736** *New*  
**WPG3036**  
**WPG3336** *New*  
**WPG3636**

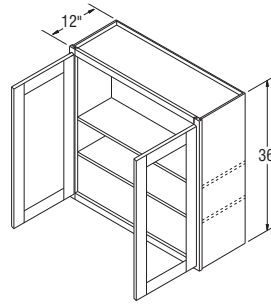

**WPG2736B** *New*  
**WPG3036B**  
**WPG3336B** *New*  
**WPG3636B**

\*Specify L or R on all single door Arch styles.

### NOTES

- ▶ Cabinets include matching Aristex® interior, two adjustable 3/4" thick matching Aristex® shelves, and clips to install glass (glass not included).
- ▶ Wall Prepped for Glass cabinets are not available in Augusta, Nantucket, Teagan, or VanWyke.
- ▶ Doors Only for WPG cabinets can be ordered to meet the need for Doors Cut for Glass.

### DESIGN SOLUTIONS

- ▶ Apply an End Panel Skin to create a flush end on the side of a Wall cabinet if installed at the end of a run for ease of Moulding installation.
- ▶ For complementary Wall Prepped for Glass cabinets in Teagan, order as Winstead Maple, as Teagan features a slab door design.

## Wall Cabinets with Doors Prepped for Glass, 36" High, 15" Deep

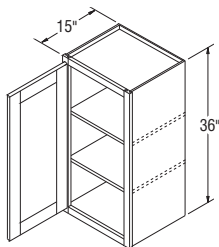

**WPG153615\*** *New*  
**WPG183615\*** *New*  
**WPG213615\*** *New*  
**WPG243615\*** *New*

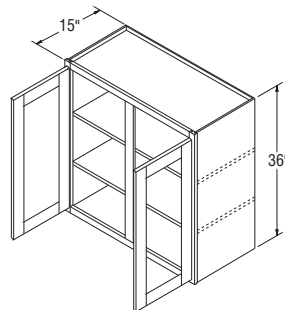

**WPG273615** *New*  
**WPG303615**  
**WPG333615** *New*  
**WPG363615**

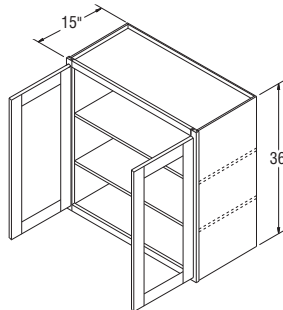

**WPG273615B** *New*  
**WPG303615B**  
**WPG333615B** *New*  
**WPG363615B**

\*Specify L or R on all single door Arch styles.

### NOTES

- ▶ Cabinets include matching Aristex® interior, two adjustable 3/4" thick matching Aristex® shelves, and clips to install glass (glass not included).
- ▶ Wall Prepped for Glass cabinets are not available in Augusta, Nantucket, Teagan, or VanWyke.
- ▶ Doors Only for WPG cabinets can be ordered to meet the need for Doors Cut for Glass.

### DESIGN SOLUTIONS

- ▶ Apply an End Panel Skin to create a flush end on the side of a Wall cabinet if installed at the end of a run for ease of Moulding installation.
- ▶ For complementary Wall Prepped for Glass cabinets in Teagan, order as Winstead Maple, as Teagan features a slab door design.

## Wall Cabinets with Doors Prepped for Glass, 42" High, 12" Deep

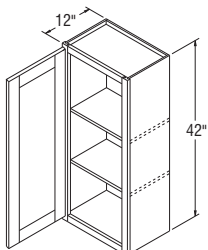

**WPG1242\*** *New*  
**WPG1542\***  
**WPG1842\***  
**WPG2142\***  
**WPG2442\***

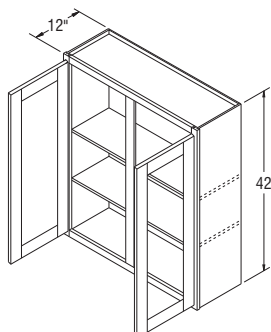

**WPG2442DD** *New*  
**WPG2742** *New*  
**WPG3042**  
**WPG3342** *New*  
**WPG3642**

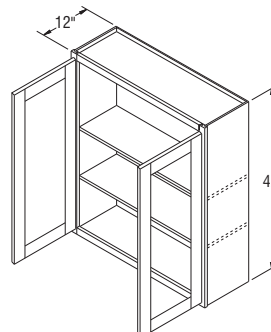

**WPG2742B** *New*  
**WPG3042B**  
**WPG3342B** *New*  
**WPG3642B**

\*Specify L or R on all single door Arch styles.

### NOTES

- ▶ Cabinets include matching Aristex® interior, two adjustable 3/4" thick matching Aristex® shelves, and clips to install glass (glass not included).
- ▶ Wall Prepped for Glass cabinets are not available in Augusta, Nantucket, Teagan, or VanWyke.
- ▶ Doors Only for WPG cabinets can be ordered to meet the need for Doors Cut for Glass.

### DESIGN SOLUTIONS

- ▶ Apply an End Panel Skin to create a flush end on the side of a Wall cabinet if installed at the end of a run for ease of Moulding installation.
- ▶ For complementary Wall Prepped for Glass cabinets in Teagan, order as Winstead Maple, as Teagan features a slab door design.

Wall Cabinets with Doors Prepped for Glass, 42" High, 15" Deep

NOTES ✓

- ▶ Cabinets include matching Aristex® interior, two adjustable ¾" thick matching Aristex® shelves, and clips to install glass (glass not included).
- ▶ Wall Prepped for Glass cabinets are not available in Augusta, Nantucket, Teagan, or VanWyke.
- ▶ Doors Only for WPG cabinets can be ordered to meet the need for Doors Cut for Glass.

DESIGN SOLUTIONS

- ▶ Apply an End Panel Skin to create a flush end on the side of a Wall cabinet if installed at the end of a run for ease of Moulding installation.
- ▶ For complementary Wall Prepped for Glass cabinets in Teagan, order as Winstead Maple, as Teagan features a slab door design.

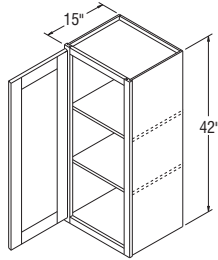

**WPG154215\*** *New*  
**WPG184215\*** *New*  
**WPG214215\*** *New*  
**WPG244215\*** *New*

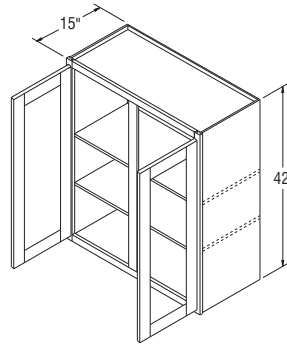

**WPG274215** *New*  
**WPG304215**  
**WPG334215** *New*  
**WPG364215**

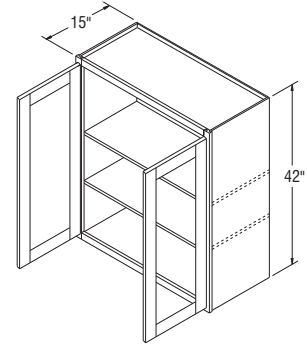

**WPG274215B** *New*  
**WPG304215B**  
**WPG334215B** *New*  
**WPG364215B**

\*Specify L or R on all single door Arch styles.

NOTES ✓

- ▶ Shelves not included.
- ▶ Cabinets use standard natural maple interior, excluding white which has a white interior.
- ▶ Cabinets must be supported on three surfaces when mounted.
- ▶ Center door on RW4812 will be hinged on the left.
- ▶ When designing for built-in refrigerators, be sure to use necessary Fillers to provide proper clearance.

DESIGN SOLUTIONS

- ▶ Apply an End Panel Skin to create a flush end on the side of a Wall cabinet if installed at the end of a run for ease of Moulding installation.

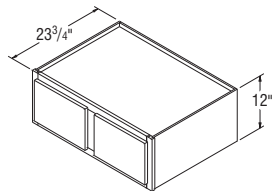

**RW3012** *New*  
**RW3312**  
**RW3612**  
**RW3912**

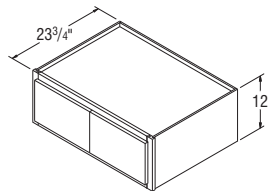

**RW3012B** *New*  
**RW3312B**  
**RW3612B**

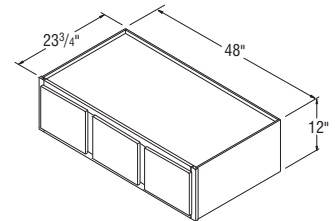

**RW4812**

Refrigerator Wall Cabinets, 14" High, 23 3/4" Deep

NOTES ✓

- ▶ Shelves not included.
- ▶ Cabinets use standard natural maple interior, excluding white which has a white interior.
- ▶ Cabinets must be supported on three surfaces when mounted.
- ▶ When designing for built-in refrigerators, be sure to use necessary Fillers to provide proper clearance.

DESIGN SOLUTIONS

- ▶ Apply an End Panel Skin to create a flush end on the side of a Wall cabinet if installed at the end of a run for ease of Moulding installation.

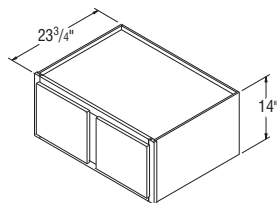

**RW3014** *New*  
**RW3314**  
**RW3614**  
**RW3914**

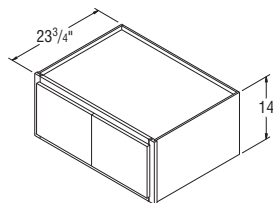

**RW3014B** *New*  
**RW3314B**  
**RW3614B**

## Refrigerator Wall Cabinets, 18" High, 23 3/4" Deep

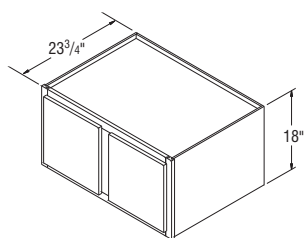

**RW3018** *New*

**RW3318**

**RW3618**

**RW3918**

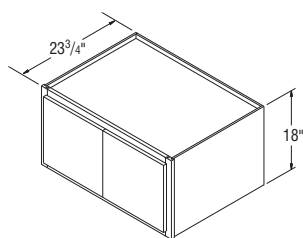

**RW3018B** *New*

**RW3318B**

**RW3618B**

### NOTES ✓

- ▶ Shelves not included.
- ▶ Cabinets use standard natural maple interior, excluding white which has a white interior.
- ▶ Cabinets must be supported on three surfaces when mounted.
- ▶ When designing for built-in refrigerators, be sure to use necessary Fillers to provide proper clearance.

### DESIGN SOLUTIONS

- ▶ Apply an End Panel Skin to create a flush end on the side of a Wall cabinet if installed at the end of a run for ease of Moulding installation.

## Refrigerator Wall Cabinets, 21" High, 23 3/4" Deep

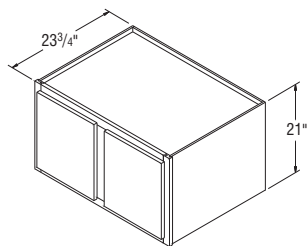

**RW3021**

**RW3321**

**RW3621**

**RW3921**

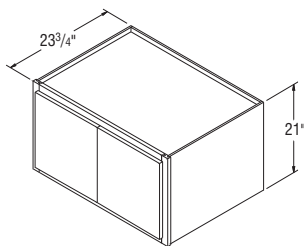

**RW3021B**

**RW3321B**

**RW3621B**

### NOTES ✓

- ▶ Shelves not included.
- ▶ Cabinets use standard natural maple interior, excluding white which has a white interior.
- ▶ Cabinets must be supported on three surfaces when mounted.
- ▶ When designing for built-in refrigerators, be sure to use necessary Fillers to provide proper clearance.

### DESIGN SOLUTIONS

- ▶ Apply an End Panel Skin to create a flush end on the side of a Wall cabinet if installed at the end of a run for ease of Moulding installation.

## Refrigerator Wall Cabinets, 24" High, 23 3/4" Deep

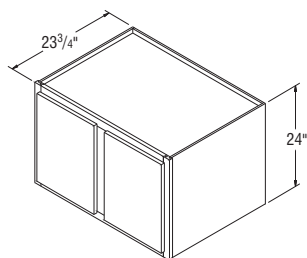

**RW3024**

**RW3324**

**RW3624**

**RW3924**

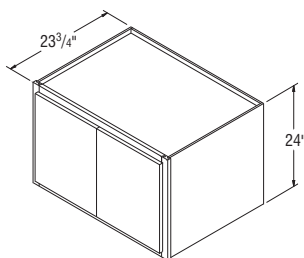

**RW3024B**

**RW3324B**

**RW3624B**

### NOTES ✓

- ▶ Shelves not included.
- ▶ Cabinets use standard natural maple interior, excluding white which has a white interior.
- ▶ Cabinets must be supported on three surfaces when mounted.
- ▶ When designing for built-in refrigerators, be sure to use necessary Fillers to provide proper clearance.

### DESIGN SOLUTIONS

- ▶ Apply an End Panel Skin to create a flush end on the side of a Wall cabinet if installed at the end of a run for ease of Moulding installation.

**NOTES** ✓

- ▶ Matching Aristex® interior.
- ▶ Can be installed horizontally or vertically.
- ▶ When installed vertically, wine rack can't be used as the end cabinet because the ends are recessed. Frame rail configuration will be unique from adjacent cabinets when installed vertically.
- ▶ WR3018 holds 11 bottles.
- ▶ WR3614 holds 13 bottles.
- ▶ Wine bottles may extend beyond face frame. Not recommended for high traffic areas.

**DESIGN SOLUTIONS**

- ▶ Apply an End Panel Skin to create a flush end on the side of a Wall cabinet if installed at the end of a run for ease of Moulding installation.

**Wine Rack Cabinets, 12" Deep**

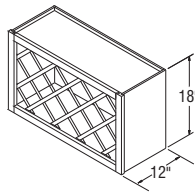

**WR3018**

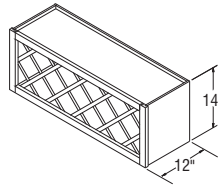

**WR3614**

**NOTES** ✓

- ▶ Matching Aristex® interior.
- ▶ Holds 14 plates.

**DESIGN SOLUTIONS**

- ▶ Apply an End Panel Skin to create a flush end on the side of a Wall cabinet if installed at the end of a run for ease of Moulding installation.

**Wall Plate Rack Cabinets, 18" High, 30" Wide, 12" Deep**

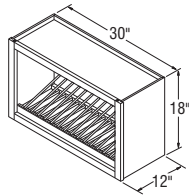

**WPR3018**

## Wall Open Cabinets with Apothecary Drawer, 47 1/2" High, 21" Wide, 12" Deep

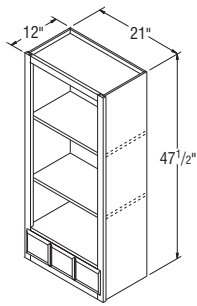

**WOL2147.5**

### NOTES ✓

- ▶ Two adjustable 3/4" thick matching Aristex® shelves.
- ▶ Cabinets include matching Aristex® interior.
- ▶ Includes an apothecary drawer with Full Extension guides.
- ▶ Units have a simulated three-panel drawer front, except the following:

SLAB	5-PIECE
Augusta	Briarcliff II
Ellsworth	Durham
	Overton

- ▶ To apply a door to this cabinet in partial overlay styles, order a door for a W2142, WMD2142, or WPG2142 (not applicable for full overlay styles due to door & drawer front interference).
- ▶ In countertop applications, backsplash must be cut out for flush installation against a wall.
- ▶ Order by door style number.
- ▶ Dovetail drawer not available.

### DESIGN SOLUTIONS

- ▶ Apply an End Panel Skin to create a flush end on the side of a Wall cabinet if installed at the end of a run for ease of Moulding installation.

## Wall Drawer Unit, 17 1/2" High, 18" Wide, 12" Deep

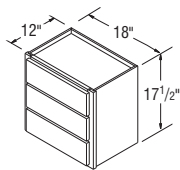

**WD1817.5**

### NOTES ✓

- ▶ Cabinets use standard natural maple interior, excluding white which has a white interior.
- ▶ Drawer guides are side-mount Full Extension.
- ▶ Dovetail drawer not available.
- ▶ Outside edge profile will match door.
- ▶ In countertop applications, backsplash must be cut out for flush installation against a wall.

### DESIGN SOLUTIONS

- ▶ Apply an End Panel Skin to create a flush end on the side of a Wall cabinet if installed at the end of a run for ease of Moulding installation.



## Wall Message Center Cabinets, 12" Wide, 3" Deep

**NOTES** ✓

- ▶ Cabinets include magnetic white board on back of door, key hooks, pencil holder, and fixed plexiglass-fronted 3/4" thick shelves.
- ▶ For proper installation, adjacent cabinet must have 1/4" panel applied, not included with WMC.
- ▶ Cabinet will have flush plywood ends to allow for application of Overlays or Split Turnings.

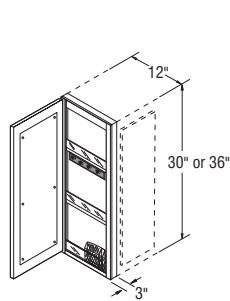

**WMC1230\***  
**WMC1236\***

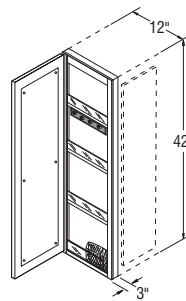

**WMC1242\***

\*Specify L or R on all styles. Cabinet should be hinged on wall side.

**NOTES** ✓

- ▶ One fixed shelf for microwave and one fixed shelf for upper section.
- ▶ Bottom shelf ships loose, includes steel peg shelf clips.
- ▶ Matching Aristex® interior throughout cabinet.
- ▶ Two doors.
- ▶ Cannot be installed next to Diagonal Wall cabinets.
- ▶ When using with 30" Wall cabinets, the MWC3036 will hang 6" below the Wall cabinet line.
- ▶ Designed for free-standing microwaves.
- ▶ Cabinet must be supported on both sides. Not intended for end of run.

## Microwave Wall Cabinets, 36" High, 30" Wide, 12" Deep

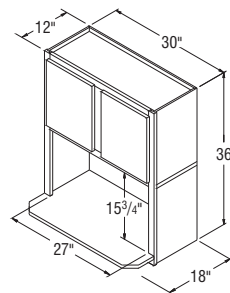

**MWC3036**

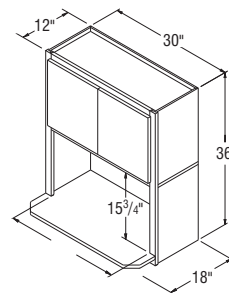

**MWC3036B**

**NOTES** ✓

- ▶ Two adjustable 3/4" shelves, one fixed shelf for microwave (bottom shelf ships loose, includes steel peg shelf clips), and one fixed shelf for upper section.
- ▶ Matching Aristex® interior throughout cabinet.
- ▶ Two doors.
- ▶ Cannot be installed next to Diagonal Wall cabinets.
- ▶ When using with 42" Wall cabinets, the MWC3048 will hang 6" below the Wall cabinet line.
- ▶ Designed for free-standing microwaves.
- ▶ Cabinet must be supported on both sides. Not intended for end of run.

## Microwave Wall Cabinets, 48" High, 30" Wide, 12" Deep

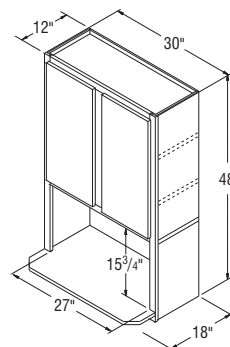

**MWC3048**

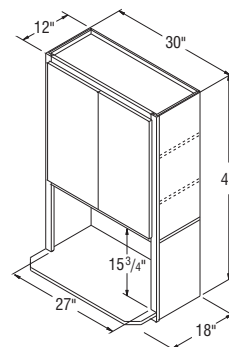

**MWC3048B**



## Wall Built-In Microwave Cabinets, 36" High, 30" Wide, 21" Deep

### NOTES ✓

- ▶ Matching Aristex® interior throughout cabinet
- ▶ Microwave opening is trimmable.
- ▶ Minimum opening – 27" W x 16 1/2" H. Maximum opening – 27" W x 20 1/2" H.
- ▶ Designed for built-in microwaves with trim kits.
- ▶ Cabinet must be supported on both sides. Not intended for end of run.

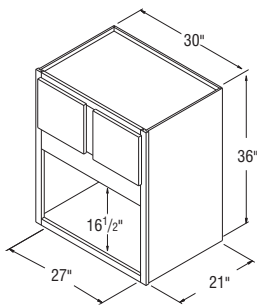

**MWC303621**

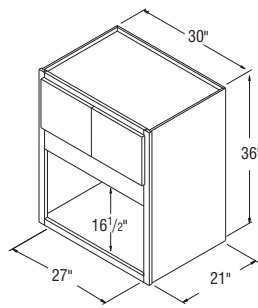

**MWC303621B**

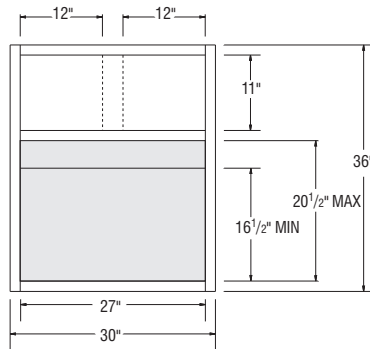

#### TRIM AREA

Center Mullion (shown with dotted line above) not applicable on butt door cabinets.



## Wall Built-In Microwave Cabinets, 42" High, 30" Wide, 21" Deep

### NOTES ✓

- ▶ Matching Aristex® interior throughout cabinet
- ▶ Microwave opening is trimmable.
- ▶ Minimum opening – 27" W x 16 1/2" H. Maximum opening – 27" W x 20 1/2" H.
- ▶ Designed for built-in microwaves with trim kits.
- ▶ Cabinet must be supported on both sides. Not intended for end of run.

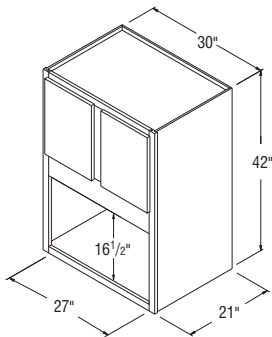

**MWC304221**

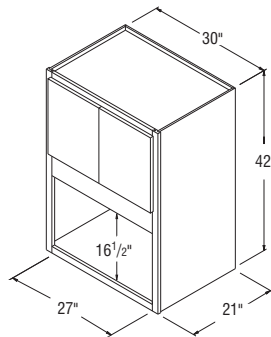

**MWC304221B**

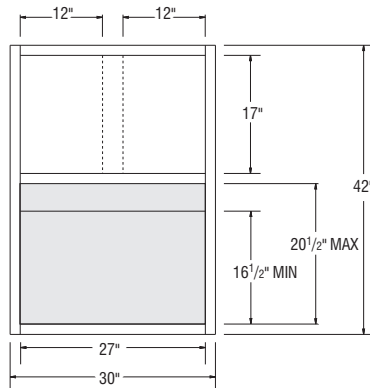

#### TRIM AREA

Center Mullion (shown with dotted line above) not applicable on butt door cabinets.



**NOTES** ✓

- ▶ Shelf extends an additional 2 1/2".
- ▶ Matching Aristex® interior.
- ▶ These units are fully assembled using special fasteners that eliminate the rabbet and groove in the End Panels and make a stronger shelf unit.
- ▶ MWS2416 opening – 22 1/2" W x 13" H.
- ▶ MWS2718 opening – 25 1/2" W x 15" H.
- ▶ Cabinet must be supported on both sides. Not intended for end of run.

**Microwave Shelf Units, 18" Deep**

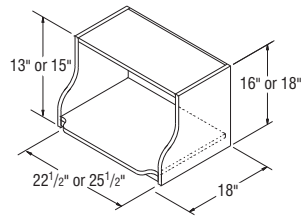

**MWS2416**  
**MWS2718**



**NOTES** ✓

- ▶ Matching veneered finish interior.
- ▶ WCUBE may be positioned horizontally or vertically.
- ▶ WCUBEDRW features four-sided drawer boxes, no slides required. Does not include decorative hardware on any style.

**Wine Cubes, 12" Deep**

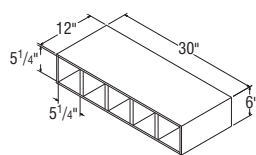

(5 openings)

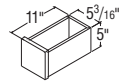

(includes 5 drawers)

**WCUBE30**  
**WCUBEDRW5**

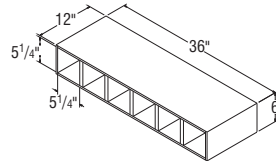

(6 openings)

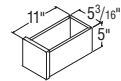

(includes 6 drawers)

**WCUBE36**  
**WCUBEDRW6**

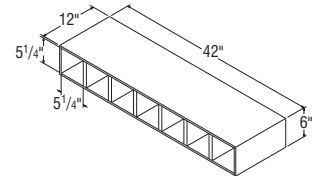

(7 openings)

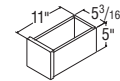

(includes 7 drawers)

**WCUBE42**  
**WCUBEDRW7**



**NOTES** ✓

- ▶ Matching veneered finish interior

**What-Not Shelves, 30" , 36" , and 42" High, 12" Wide, 5" Deep**

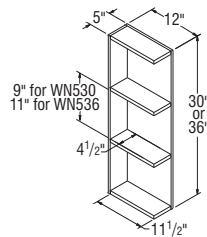

**WN530**  
**WN536**

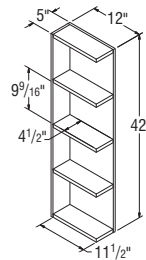

**WN542**



## Canopy Wood Hoods, Arch, 30" and 36" Wide, 24" High

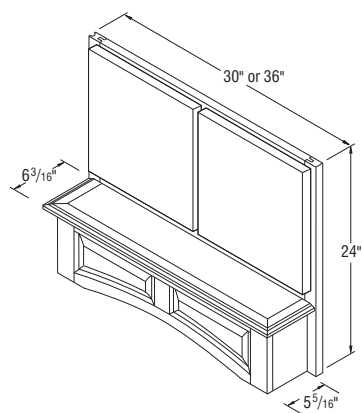

**WHCA30**  
**WHCA36**

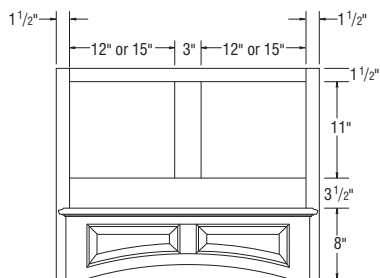

### NOTES ✓

- ▶ Butt door styles will utilize butt door sizes, frame will always have a 3" center mullion.
- ▶ Install Wood Hoods between adjoining 12" deep cabinets (15" deep cabinets are not recommended).
- ▶ Doors matching the style ordered will be installed on hood.
- ▶ Durham and Overton Toasted Antique doors will have a glazed appearance, but rest of wood hood unit will be painted Antique.
- ▶ Wood Hoods ordered in Rustic Birch will not feature Rustic characteristics.
- ▶ Exhaust system not included. Compatible with TWHBLOWER390 and TWHCONVKIT.
- ▶ Check your local building code for installation heights above the range.
- ▶ Silver metallic liner included. Liner opening size: 10 1/2" deep by 19 1/2" wide. Assembly required.
- ▶ Installation instructions and hardware included.

## Canopy Wood Hoods, Square, 30" and 36" Wide, 24" High

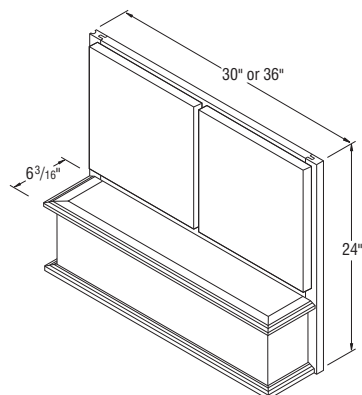

**WHCS30**  
**WHCS36**

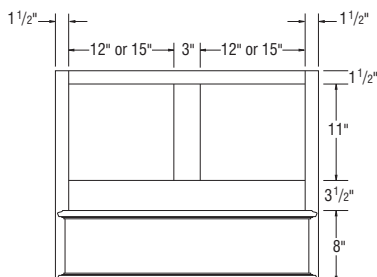

### NOTES ✓

- ▶ Butt door styles will utilize butt door sizes, frame will always have a 3" center mullion.
- ▶ Install Wood Hoods between adjacent cabinets.
- ▶ Doors matching the style ordered will be installed on hood.
- ▶ Durham and Overton Toasted Antique doors will have a glazed appearance, but rest of wood hood unit will be painted Antique.
- ▶ Wood Hoods ordered in Rustic Birch will not feature Rustic characteristics.
- ▶ Exhaust system not included. Compatible with TWHBLOWER390 and TWHCONVKIT.
- ▶ Check your local building code for installation heights above the range.
- ▶ Silver metallic liner included. Liner opening size: 10 1/2" deep by 19 1/2" wide. Assembly required.
- ▶ Installation instructions and hardware included.
- ▶ Square Canopy Wood Hoods (WHCS30 & WHCS36) are designed to be used with Acanthus Overlay (ACOVLY).

Tapered Wood Hoods, 30" and 36" Wide, 24" High

NOTES ✓

- ▶ Silver metallic liner included. Liner opening size: 10<sup>3</sup>/<sub>4</sub>" deep by 19<sup>1</sup>/<sub>2</sub>" wide. Assembly required.
- ▶ Install Wood Hoods between adjoining 12" deep cabinets (15" deep cabinets are not recommended).
- ▶ When Antique is used for Durham and Overton, wood hood unit will not feature a glazed appearance. Toasted Antique not available.
- ▶ Check your local building code for installation heights above the range.
- ▶ TWH36 has two plain/fluted stiles with metal wings included to extend Hood to 36" width.
- ▶ Blower unit is not included. See below for TWHBLOWER390 and TWHCONVKIT.
- ▶ Wood Hoods are designed to be used with Acanthus Overlay (ACOVLY).

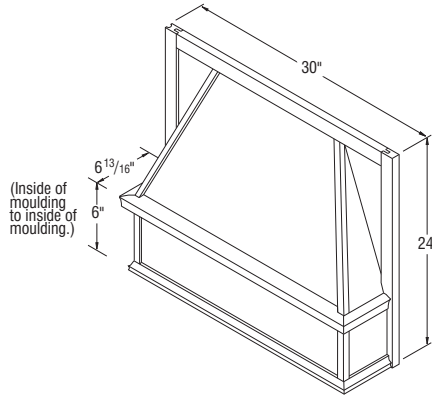

TWH30

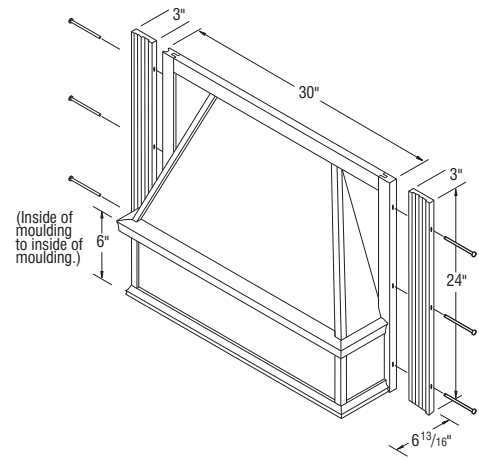

TWH36

NOTES ✓

- ▶ Compatible with WHCA, WHCS, and TWH Wood Hoods.
- ▶ 6" diameter vent.
- ▶ Silver metallic finish.
- ▶ One year warranty.
- ▶ Two 40-watt candelabra lights, (not included), and three fan setting levels.
- ▶ CFM Rating – Maximum 390 CFM (cubic feet per minute).
- ▶ Order under style #010. Manufacturer recommends 24"-30" clearance between cooking surface and blower unit.
- ▶ Includes a dishwasher-safe aluminum filter for use with external ducting. Does not include charcoal filter for internal ducting with conversion kit (see FILTER390).

Wood Hood Blower

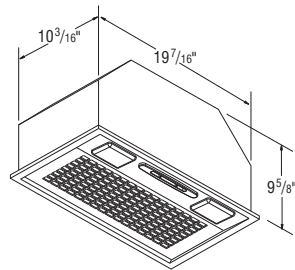

TWHBLOWER390



NOTES ✓

- ▶ Kit allows TWHBLOWER390 to be vented internally.
- ▶ Order under style #010.
- ▶ Kit includes: One 21" x 7" round pipe, 1 adjustable collar, 1 white metal soffit grille, 1 adjustable boot, a 7" to 6" reducer, and FILTER390
- ▶ FILTER390 also available to order separately for replacements.

Wood Hood Conversion Kit

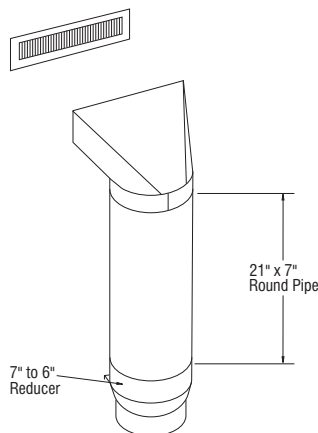

TWHCONVKIT



**FILTER390**

- ▶ Replacement charcoal filter for use when wood hood blower (TWHBLOWER390) is ducted internally with the wood hood conversion kit (TWHCONVKIT).



**Diagonal Corner Wall Cabinets, 30" High, 12" & 15" Deep**

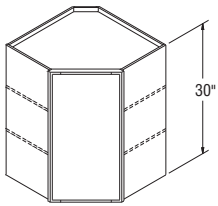

**DC2430\***  
**DC2730\***

\*Specify L or R on Arch styles.

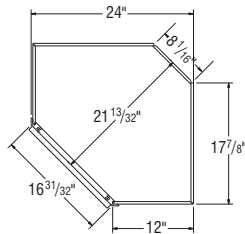

DC2430  
TOP VIEW

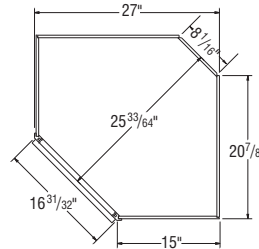

DC2730  
TOP VIEW

- ▶ Two adjustable shelves.
- ▶ Cabinets use standard natural maple interior, excluding white which has a white interior
- ▶ All Diagonal Wall cabinets are reversible except for Arch styles.
- ▶ When installing, DC cabinets must be attached to at least one run of cabinets and both back walls.
- ▶ All full overlay doors are smaller to allow for proper door opening.

**DESIGN SOLUTIONS**

- ▶ Apply an End Panel Skin to create a flush end on the side of a Wall cabinet if installed at the end of a run for ease of Moulding installation.

**Diagonal Corner Wall Cabinets, 36" High, 12" & 15" Deep**

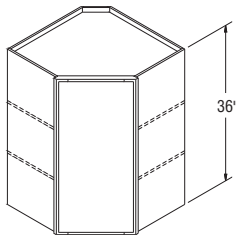

**DC2436\***  
**DC2736\***

\*Specify L or R on Arch styles.

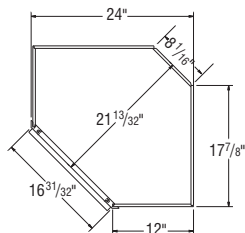

DC2436  
TOP VIEW

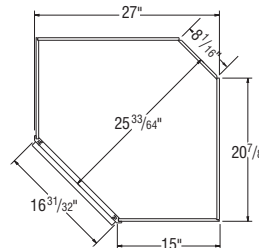

DC2736  
TOP VIEW

- ▶ Two adjustable shelves.
- ▶ Cabinets use standard natural maple interior, excluding white which has a white interior.
- ▶ All Diagonal Wall cabinets are reversible except for Arch styles.
- ▶ When installing, DC cabinets must be attached to at least one run of cabinets and both back walls.
- ▶ All full overlay doors are smaller to allow for proper door opening.

**DESIGN SOLUTIONS**

- ▶ Apply an End Panel Skin to create a flush end on the side of a Wall cabinet if installed at the end of a run for ease of Moulding installation.

NOTES ✓

- ▶ Three adjustable shelves.
- ▶ Cabinets use standard natural maple interior, excluding white which has a white interior.
- ▶ All Diagonal Wall cabinets are reversible except for Arch styles.
- ▶ When installing, DC cabinets must be attached to at least one run of cabinets and both back walls.
- ▶ All full overlay doors are smaller to allow for proper door opening.
- ▶ When varying heights, make sure to also vary depths to allow moulding to lie against adjacent side of cabinet.

DESIGN SOLUTIONS

- ▶ Apply an End Panel Skin to create a flush end on the side of a Wall cabinet if installed at the end of a run for ease of Moulding installation.

Diagonal Corner Wall Cabinets, 42" High, 12" & 15" Deep

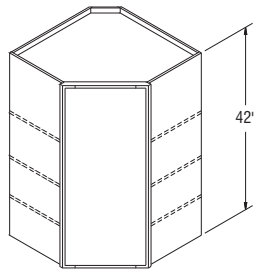

DC2442\*  
DC2742\*

\*Specify L or R on Arch styles.

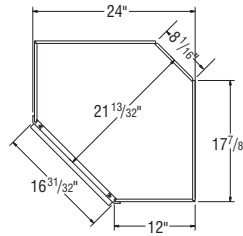

DC2442  
TOP VIEW

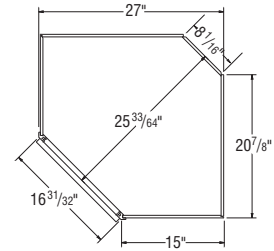

DC2742  
TOP VIEW

NOTES ✓

- ▶ Two adjustable 3/4" thick matching Aristex® shelves.
- ▶ Cabinets include matching Aristex® interior.
- ▶ If a door is desired for a 7/16" partial overlay style, use a W1830 size door.
- ▶ Full overlay door styles cannot be added.
- ▶ When installing, DCOL cabinets must be attached to at least one run of cabinets and both back walls.

DESIGN SOLUTIONS

- ▶ Apply an End Panel Skin to create a flush end on the side of a Wall cabinet if installed at the end of a run for ease of Moulding installation.

Diagonal Corner Open Wall Cabinets, 30" High, 12" & 15" Deep

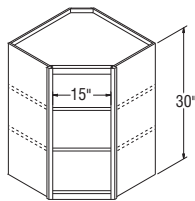

DCOL2430  
DCOL2730

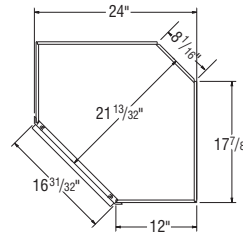

DCOL2430  
TOP VIEW

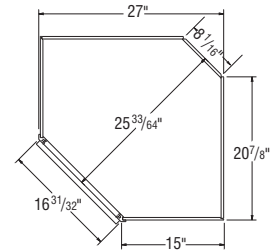

DCOL2730  
TOP VIEW

## Diagonal Corner Open Wall Cabinets, 36" High, 12" & 15" Deep

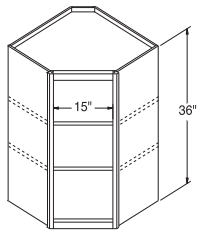

**DCOL2436**  
**DCOL2736**

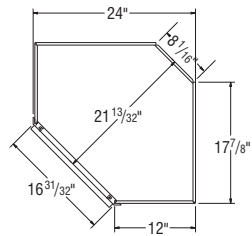

**DCOL2436**  
**TOP VIEW**

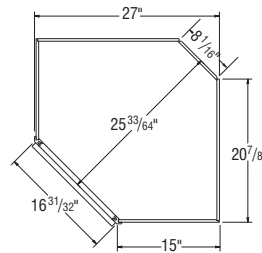

**DCOL2736**  
**TOP VIEW**

### NOTES ✓

- ▶ Two adjustable  $\frac{3}{4}$ " thick matching Aristex® shelves.
- ▶ Cabinets include matching Aristex® interior.
- ▶ If a door is desired for a  $\frac{7}{16}$ " partial overlay style, use a W1836 size door.
- ▶ Full overlay door styles cannot be added.
- ▶ When installing, DCOL cabinets must be attached to at least one run of cabinets and both back walls.

### DESIGN SOLUTIONS

- ▶ Apply an End Panel Skin to create a flush end on the side of a Wall cabinet if installed at the end of a run for ease of Moulding installation.

## Diagonal Corner Open Wall Cabinets, 42" High, 12" & 15" Deep

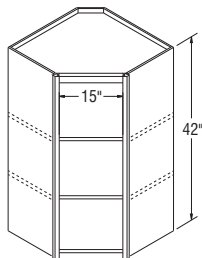

**DCOL2442**  
**DCOL2742**

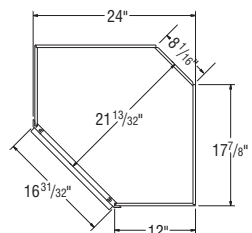

**DCOL2442 TOP VIEW**

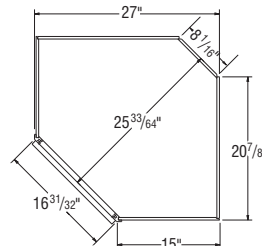

**DCOL2742 TOP VIEW**

### NOTES ✓

- ▶ Two adjustable  $\frac{3}{4}$ " thick matching Aristex® shelves.
- ▶ Cabinets include matching Aristex® interior.
- ▶ If a door is desired for a  $\frac{7}{16}$ " partial overlay style, use a W1842 size door.
- ▶ Full overlay door styles cannot be added.
- ▶ When installing, DCOL cabinets must be attached to at least one run of cabinets and both back walls.

### DESIGN SOLUTIONS

- ▶ Apply an End Panel Skin to create a flush end on the side of a Wall cabinet if installed at the end of a run for ease of Moulding installation.

**NOTES** ✓

- ▶ Two adjustable 3/4" thick matching Aristex® shelves align with door mullions on Standard mullions, but do not align on Shaker mullions
- ▶ Cabinets include installed, clear tempered glass, and matching Aristex® interior.
- ▶ All Diagonal Wall cabinets are reversible except for Arch styles.
- ▶ When installing, DCMD cabinets must be attached to at least one run of cabinets and both back walls.
- ▶ All full overlay doors are smaller to allow for proper door opening.
- ▶ See page 24 for Standard and Shaker mullion door style availability and grid configurations.
- ▶ Mullion Door cabinets are not available in Ellsworth, Teagan, or VanWyke.

**DESIGN SOLUTIONS**

- ▶ Apply an End Panel Skin to create a flush end on the side of a Wall cabinet if installed at the end of a run for ease of Moulding installation.
- ▶ For complementary Wall Mullion Door cabinets in Teagan, order as Winstead Maple, as Teagan features a slab door design.

**Diagonal Corner Wall Cabinets with Mullion Door, 30" High, 12" & 15" Deep**

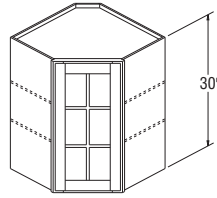

**DCMD2430\***  
**DCMD2730\***

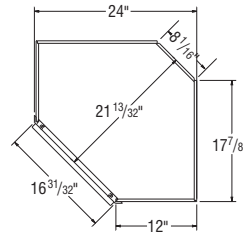

DCMD2430  
TOP VIEW

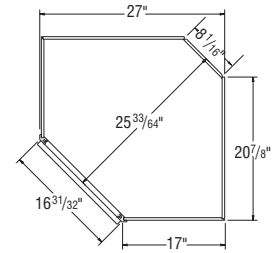

DCMD2730  
TOP VIEW

\*Specify L or R on Arch styles.

**NOTES** ✓

- ▶ Two adjustable 3/4" thick matching Aristex® shelves align with door mullions on Standard mullions, but do not align on Shaker mullions
- ▶ Cabinets include installed, clear tempered glass, and matching Aristex® interior.
- ▶ All Diagonal Wall cabinets are reversible except for Arch styles.
- ▶ When installing, DCMD cabinets must be attached to at least one run of cabinets and both back walls.
- ▶ All full overlay doors are smaller to allow for proper door opening.
- ▶ See page 24 for Standard and Shaker mullion door style availability and grid configurations.
- ▶ Mullion Door cabinets are not available in Ellsworth, Teagan, or VanWyke.

**DESIGN SOLUTIONS**

- ▶ Apply an End Panel Skin to create a flush end on the side of a Wall cabinet if installed at the end of a run for ease of Moulding installation.
- ▶ For complementary Wall Mullion Door cabinets in Teagan, order as Winstead Maple, as Teagan features a slab door design.

**Diagonal Corner Wall Cabinets with Mullion Door, 36" High, 12" & 15" Deep**

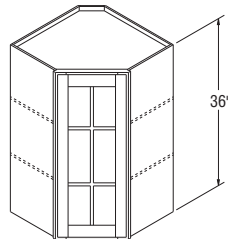

**DCMD2436\***  
**DCMD2736\***

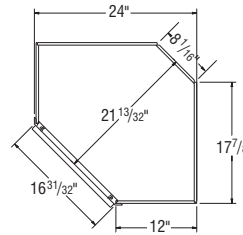

DCMD2436  
TOP VIEW

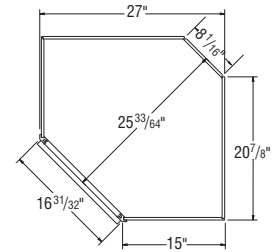

DCMD2736  
TOP VIEW

\*Specify L or R on Arch styles.

## Diagonal Corner Wall Cabinets with Mullion Door, 42" High, 12" & 15" Deep

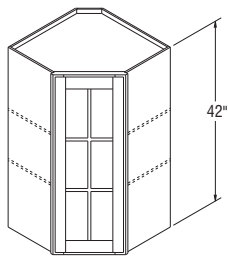

**DCMD2442\***  
**DCMD2742\***

\*Specify L or R on Arch styles.

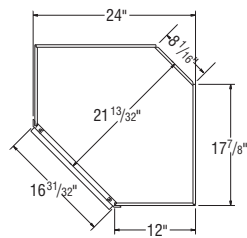

DCMD2442  
TOP VIEW

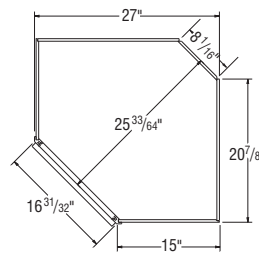

DCMD2742  
TOP VIEW

### NOTES

- ▶ Two adjustable  $\frac{3}{4}$ " thick matching Aristex® shelves align with door mullions on Standard mullions, but do not align on Shaker mullions.
- ▶ Cabinets include installed, clear tempered glass, and matching Aristex® interior.
- ▶ All Diagonal Wall cabinets are reversible except for Arch styles.
- ▶ When installing, DCMD cabinets must be attached to at least one run of cabinets and both back walls.
- ▶ All full overlay doors are smaller to allow for proper door opening.
- ▶ See page 24 for Standard and Shaker mullion door style availability and grid configurations.
- ▶ Mullion Door cabinets are not available in Ellsworth, Teagan, or VanWyke.

### DESIGN SOLUTIONS

- ▶ Apply an End Panel Skin to create a flush end on the side of a Wall cabinet if installed at the end of a run for ease of Moulding installation.
- ▶ For complementary Wall Mullion Door cabinets in Teagan, order as Winstead Maple, as Teagan features a slab door design.

## Diagonal Corner Wall Cabinets w/Door Prepped for Glass, 30" High, 12" & 15" Deep

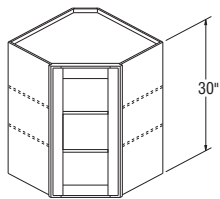

**DCPG2430\***  
**DCPG2730\***

\*Specify L or R on Arch styles.

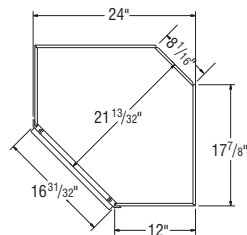

DCPG2430  
TOP VIEW

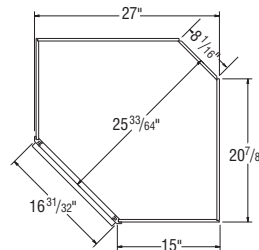

DCPG2730  
TOP VIEW

### NOTES

- ▶ Cabinets include matching Aristex® interior, two adjustable  $\frac{3}{4}$ " thick matching Aristex® shelves, and clips to install glass (glass not included).
- ▶ All Diagonal Wall cabinets are reversible except for Arch styles.
- ▶ When installing, DCPG cabinets must be attached to at least one run of cabinets and both back walls.
- ▶ All full overlay doors are smaller to allow for proper door opening.
- ▶ Wall Prepped for Glass cabinets are not available in Nantucket, Augusta, or Teagan.

### DESIGN SOLUTIONS

- ▶ Apply an End Panel Skin to create a flush end on the side of a Wall cabinet if installed at the end of a run for ease of Moulding installation.
- ▶ For complementary Wall Mullion Door cabinets in Teagan, order as Winstead Maple, as Teagan features a slab door design.

**NOTES** ✓

- ▶ Cabinets include matching Aristex® interior, two adjustable ¾" thick matching Aristex® shelves, and clips to install glass (glass not included).
- ▶ All Diagonal Wall cabinets are reversible except for Arch styles
- ▶ When installing, DCPG cabinets must be attached to at least one run of cabinets and both back walls.
- ▶ All full overlay doors are smaller to allow for proper door opening.
- ▶ Wall Prepped for Glass cabinets are not available in Nantucket, Augusta, or Teagan.

**DESIGN SOLUTIONS**

- ▶ Apply an End Panel Skin to create a flush end on the side of a Wall cabinet if installed at the end of a run for ease of Moulding installation.
- ▶ For complementary Wall Mullion Door cabinets in Teagan, order as Winstead Maple, as Teagan features a slab door design.

Diagonal Corner Wall Cabinets w/Door Prepped for Glass, 36" High, 12" & 15" Deep

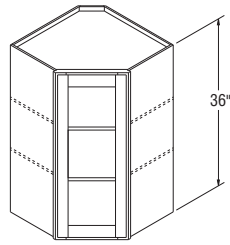

**DCPG2436\***  
**DCPG2736\***

\*Specify L or R on Arch styles.

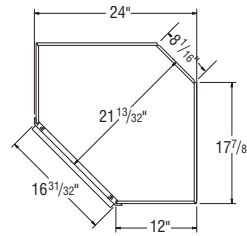

DCPG2436  
TOP VIEW

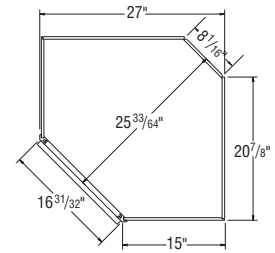

DCPG2736  
TOP VIEW

**NOTES** ✓

- ▶ Cabinets include matching Aristex® interior, two adjustable ¾" thick matching Aristex® shelves, and clips to install glass (glass not included).
- ▶ All Diagonal Wall cabinets are reversible except for Arch styles.
- ▶ When installing, DCPG cabinets must be attached to at least one run of cabinets and both back walls.
- ▶ All full overlay doors are smaller to allow for proper door opening.
- ▶ Wall Prepped for Glass cabinets are not available in Augusta, Nantucket, Teagan, or VanWyke.

**DESIGN SOLUTIONS**

- ▶ Apply an End Panel Skin to create a flush end on the side of a Wall cabinet if installed at the end of a run for ease of Moulding installation.
- ▶ For complementary Wall Mullion Door cabinets in Teagan, order as Winstead Maple, as Teagan features a slab door design.

Diagonal Corner Wall Cabinets w/Door Prepped for Glass, 42" High, 12" & 15" Deep

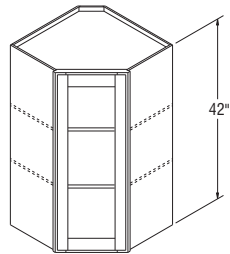

**DCPG2442\***  
**DCPG2742\***

\*Specify L or R on Arch styles.

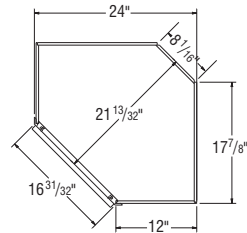

DCPG2442  
TOP VIEW

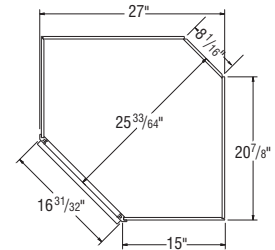

DCPG2742  
TOP VIEW

## Diagonal Corner Roto Wall Cabinet, 30" High, 12" Deep

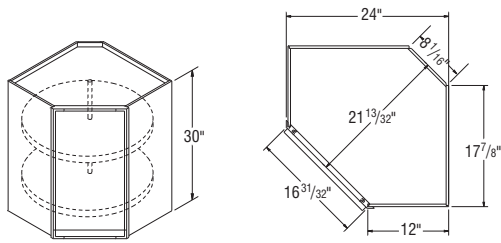

**DCR2430\***

TOP VIEW

\*Specify L or R on Arch styles.

### NOTES ✓

- ▶ Includes two white Roto shelves. Each shelf holds 30 lbs.
- ▶ 18" diameter shelves.
- ▶ Cabinets use standard natural maple interior, excluding white which has a white interior.
- ▶ Doors are reversible except for Arch styles.
- ▶ Cabinets must be attached to at least one run of cabinets and both back walls.

### DESIGN SOLUTIONS

- ▶ Apply an End Panel Skin to create a flush end on the side of a Wall cabinet if installed at the end of a run for ease of Moulding installation.



## Wall Easy Reach Cabinet, 30", 36", or 42" High, 12" Deep

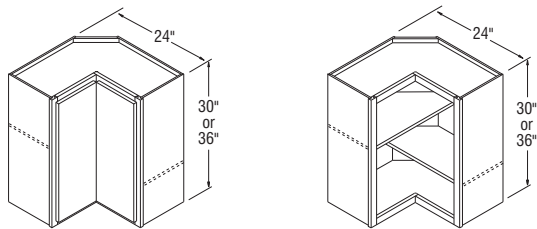

**WER2430\***  
**WER2436\***

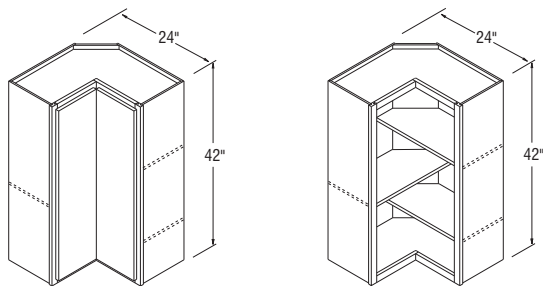

**WER2442\***

\*Specify L or R on Arch styles.

### NOTES ✓

- ▶ WER2430 and WER2436 include two adjustable shelves.
- ▶ WER2442 includes three adjustable shelves.
- ▶ Cabinets use standard natural maple interior, excluding white which has a white interior.
- ▶ Doors are reversible except for Arch styles.
- ▶ One piano hinged door.
- ▶ Includes magnetic catch.
- ▶ Cabinets must be attached to at least one run of cabinets and both back walls.

### DESIGN SOLUTIONS

- ▶ Apply an End Panel Skin to create a flush end on the side of a Wall cabinet if installed at the end of a run for ease of Moulding installation.

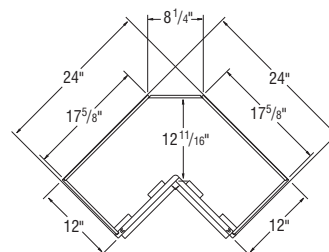

Square Corner Wall Cabinets, 30" High, 12" Deep

NOTES ✓

- ▶ Two adjustable shelves.
- ▶ Cabinets use standard natural maple interior, excluding white which has a white interior
- ▶ 3" Filler is included. Filler Overlays shipped unattached with Briarcliff II, Dryden, Durham, Eastland, Nantucket, Overton, and Wentworth styles.
- ▶ Hinging determines location of the blind. Door attaches to blind panel
- ▶ Cabinets are reversible, except for Arch styles.
- ▶ Cover panel shipped with cabinet for field installation to cover 6" blind opening.

DESIGN SOLUTIONS

- ▶ When a cabinet is "pulled," it will use proportionally more wall space. For example, a 30" wide Wall cabinet pulled 2" will use 32" of space.
- ▶ Blind side of Wall Corner cabinets cannot be installed next to a Range Hood or Microwave Shelf due to door interference.

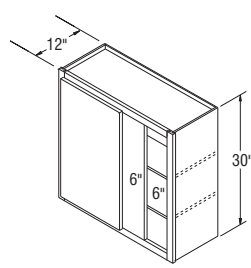

SC2430\*  
SC3030\*  
SC3330\*  
SC3630\*

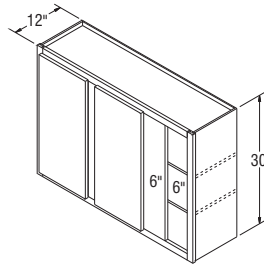

SC4230\*  
SC4830\*

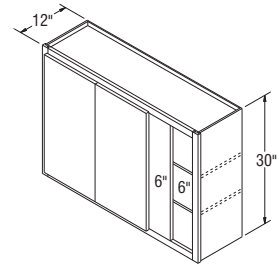

SC4230B\*  
SC4830B\*

\*Specify L or R blind designation on all Arch styles.



TOP VIEW  
SC (RIGHT)



TOP VIEW  
SC (LEFT)



TOP VIEW  
SC (RIGHT)



TOP VIEW  
SC (LEFT)

Square Corner Wall Cabinets, 36" High, 12" Deep

NOTES ✓

- ▶ Two adjustable shelves.
- ▶ Cabinets use standard natural maple interior, excluding white which has a white interior
- ▶ 3" Filler is included. Filler Overlays shipped unattached with Briarcliff II, Dryden, Durham, Eastland, Nantucket, Overton, and Wentworth styles.
- ▶ Hinging determines location of the blind. Door attaches to blind panel
- ▶ Cabinets are reversible, except for Arch styles.
- ▶ Cover panel shipped with cabinet for field installation to cover 6" blind opening.

DESIGN SOLUTIONS

- ▶ When a cabinet is "pulled," it will use proportionally more wall space. For example, a 30" wide Wall cabinet pulled 2" will use 32" of space.
- ▶ Blind side of Wall Corner cabinets cannot be installed next to a Range Hood or Microwave Shelf due to door interference.

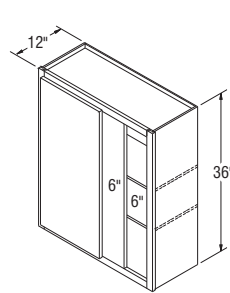

SC2436\*  
SC3036\*  
SC3336\*  
SC3636\*

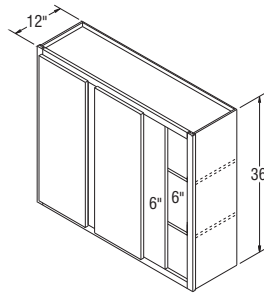

SC4236\* *New*  
SC4836\* *New*

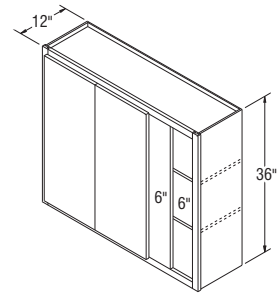

SC4236B\* *New*  
SC4836B\* *New*

\*Specify L or R blind designation on all Arch styles.



TOP VIEW  
SC (RIGHT)



TOP VIEW  
SC (LEFT)



TOP VIEW  
SC (RIGHT)



TOP VIEW  
SC (LEFT)

# Square Corner Wall Cabinets, 42" High, 12" Deep

## NOTES

- ▶ Three adjustable shelves.
- ▶ Cabinets use standard natural maple interior, excluding white which has a white interior
- ▶ 3" Filler is included. Filler Overlays shipped unattached with Briarcliff II, Dryden, Durham, Eastland, Nantucket, Overton, and Wentworth styles.
- ▶ Hinging determines location of the blind. Door attaches to blind panel
- ▶ Cabinets are reversible, except for Arch styles.
- ▶ Cover panel shipped with cabinet for field installation to cover 6" blind opening.

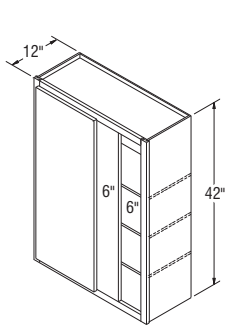

**SC2442\***  
**SC3042\***  
**SC3342\***  
**SC3642\***

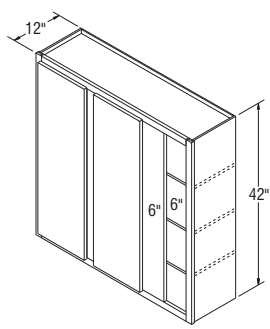

**SC4242\***  
**SC4842\***

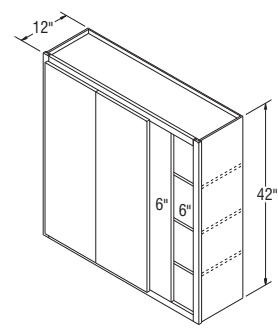

**SC4242B\***  
**SC4842B\***

\*Specify L or R blind designation on all Arch styles.

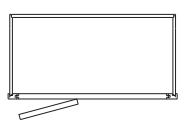

TOP VIEW  
SC (RIGHT)

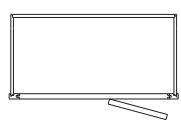

TOP VIEW  
SC (LEFT)

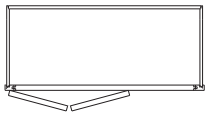

TOP VIEW  
SC (RIGHT)

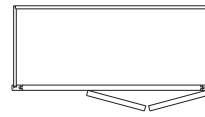

TOP VIEW  
SC (LEFT)

## DESIGN SOLUTIONS

- ▶ When a cabinet is "pulled," it will use proportionally more wall space. For example, a 30" wide Wall cabinet pulled 2" will use 32" of space.
- ▶ Blind side of Wall Corner cabinets cannot be installed next to a Range Hood or Microwave Shelf due to door interference.

# Square Corner Cabinet Information

## KEY

- X: Minimum pull for Square Corner cabinets.
- Y: Maximum pull for Square Corner cabinets.
- Z: Minimum filler size required between cabinets.
- ▶ Minimum pull figured when Square Corner Wall or adjacent cabinet doors can open 90 degrees.

Square Corner Wall	X		Y	Z	
	Min. Pull	Min. Pull w/Hardware	Max. Pull	Min. Filler Required	Min. Filler Required w/Hardware
<b>Full Overlay Styles</b>	1"	2½"	3¾"	1"	2½"
<b>¾" Overlay Styles</b>	½"	2"	3¾"	1½"	2"

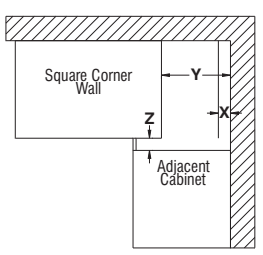



## Peninsula Wall Cabinets, 18" High, 12" Deep

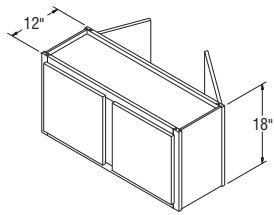

**PW3018**  
**PW3618**

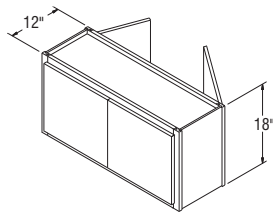

**PW3018B**  
**PW3618B**

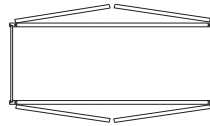

TOP VIEW

### NOTES ✓

- ▶ No shelves.
- ▶ Cabinets use standard natural maple interior, excluding white which has a white interior.

### DESIGN SOLUTIONS

- ▶ Apply an End Panel Skin to create a flush end on the side of a Wall cabinet if installed at the end of a run for ease of Moulding installation.

## Peninsula Wall Cabinets, 24" High, 12" Deep

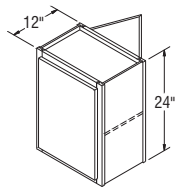

**PW1824**  
**PW2424**

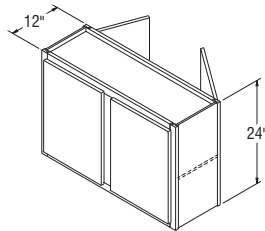

**PW3024**  
**PW3624**

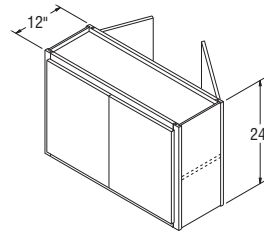

**PW3024B**  
**PW3624B**

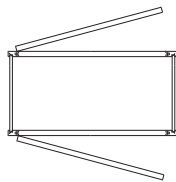

TOP VIEW

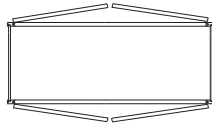

TOP VIEW

### NOTES ✓

- ▶ One adjustable shelf.
- ▶ Cabinets use standard natural maple interior, excluding white which has a white interior
- ▶ Single door reversible.

### DESIGN SOLUTIONS

- ▶ Apply an End Panel Skin to create a flush end on the side of a Wall cabinet if installed at the end of a run for ease of Moulding installation.

**NOTES** ✓

- ▶ Two adjustable shelves.
- ▶ Cabinets use standard natural maple interior, excluding white which has a white interior
- ▶ Single door reversible.

**DESIGN SOLUTIONS**

- ▶ Apply an End Panel Skin to create a flush end on the side of a Wall cabinet if installed at the end of a run for ease of Moulding installation.

**Peninsula Wall Cabinets, 30" High, 12" Deep**

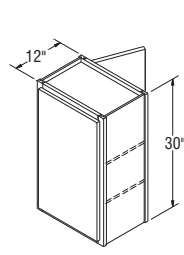

**PW1830  
PW2430**

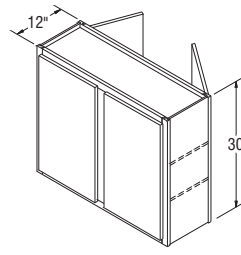

**PW3030  
PW3630**

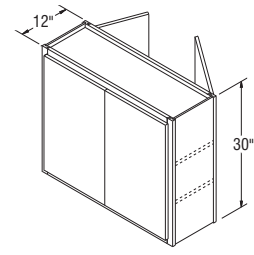

**PW3030B  
PW3630B**

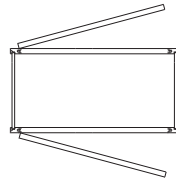

TOP VIEW

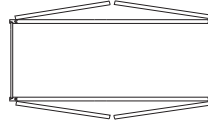

TOP VIEW

**NOTES** ✓

- ▶ One adjustable 3/4" thick matching Aristex® shelf aligns with door mullions on Standard mullions, but does not align on Shaker mullions.
- ▶ Cabinets include installed clear tempered glass and matching Aristex® interior.
- ▶ Matching Aristex® interior.
- ▶ All doors are mullion.
- ▶ Backs of face frames are unfinished. See page 24 for Standard and Shaker mullion door style availability and grid configurations.
- ▶ Peninsula Mullion Door cabinets are not available in Ellsworth, Teagan, or VanWyke.

**DESIGN SOLUTIONS**

- ▶ Apply an End Panel Skin to create a flush end on the side of a Wall cabinet if installed at the end of a run for ease of Moulding installation.
- ▶ For complementary Peninsula Wall Mullion Door cabinets in Teagan, order as Winstead Maple, as Teagan features a slab door design.

**Peninsula Wall Cabinets with 4 Mullion Doors, 24" High, 12" Deep**

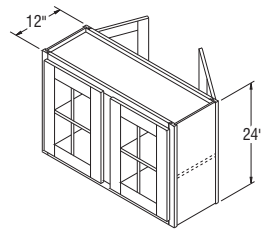

**PWMD3024  
PWMD3624**

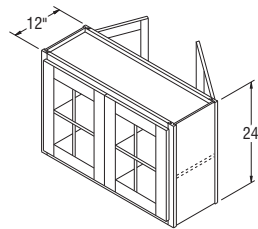

**PWMD3024B  
PWMD3624B**

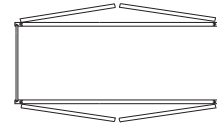

TOP VIEW

## Peninsula Wall Cabinets with 4 Doors Prepped for Glass, 24" High, 12" Deep

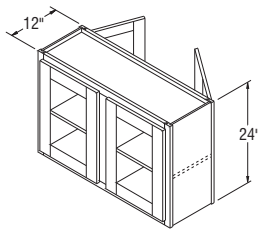

**PWPG3024**  
**PWPG3624**

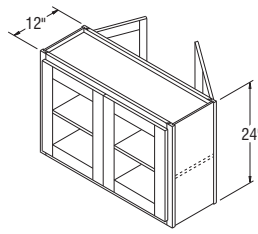

**PWPG3024B**  
**PWPG3624B**

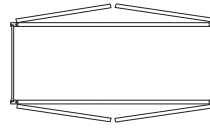

TOP VIEW

### NOTES ✓

- ▶ Cabinets include matching Aristex® interior, one adjustable ¾" thick shelf, and clips to install glass (glass not included).
- ▶ Peninsula Wall Prepped for Glass cabinets are not available in Augusta, Nantucket, Teagan, or VanWyke.

### DESIGN SOLUTIONS

- ▶ Apply an End Panel Skin to create a flush end on the side of a Wall cabinet if installed at the end of a run for ease of Moulding installation.
- ▶ For complementary Peninsula Wall Prepped for Glass cabinets in Teagan, order as Winstead Maple, as Teagan features a slab door design.

## Peninsula Diagonal Corner Wall Cabinets, 30" High, 12" Deep

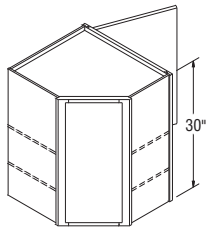

**PDCL2430\***  
**PDCR2430\***

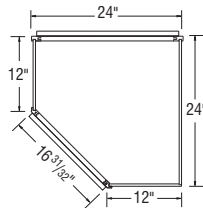

TOP VIEW

\*Specify L or R to indicate hinging for front door on all styles.

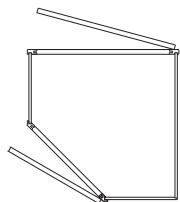

TOP VIEW  
Peninsula Door - Left  
Front Door Hinge - Right

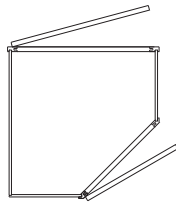

TOP VIEW  
Peninsula Door - Right  
Front Door Hinge - Left

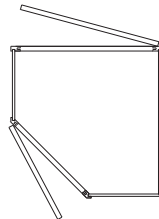

TOP VIEW  
Peninsula Door - Left  
Front Door Hinge - Left

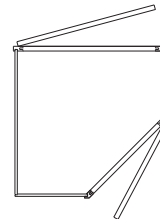

TOP VIEW  
Peninsula Door - Right  
Front Door Hinge - Right

### NOTES ✓

- ▶ Two adjustable shelves.
- ▶ Cabinets use standard natural maple interior, excluding white which has a white interior.
- ▶ When installing, the cabinet must be attached to at least one run of cabinets, the back wall, and the soffit for structural stability.
- ▶ All styles reversible except Arch.

### DESIGN SOLUTIONS

- ▶ Apply an End Panel Skin to create a flush end on the side of a Wall cabinet if installed at the end of a run for ease of Moulding installation.

NOTES ✓

- ▶ B09 has one door and one built-in tray divider. Nantucket and Grayson B09 cabinet doors utilize recessed center panels.
- ▶ Includes one fixed 1/2" thick half-depth shelf.

Base Cabinets, 35" High, 23 3/4" Deep

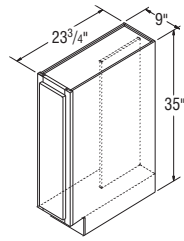

**B09**

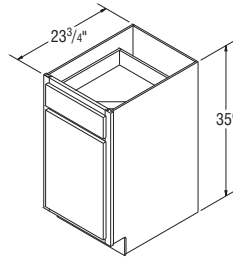

**B12** FX **B21** FX  
**B15** FX **B24** FX  
**B18** FX

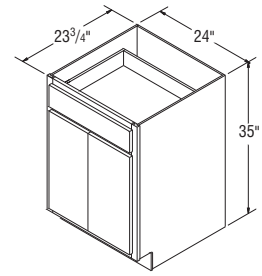

**B24DD** FX

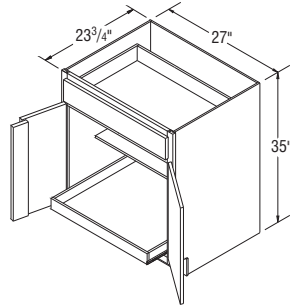

**B27** FX

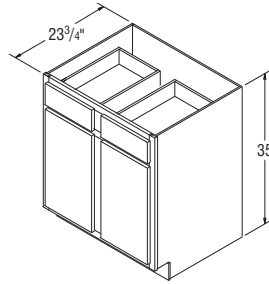

**B30** FX **B42** FX  
**B33** FX **B45** FX  
**B36** FX **B48** FX  
**B39** FX

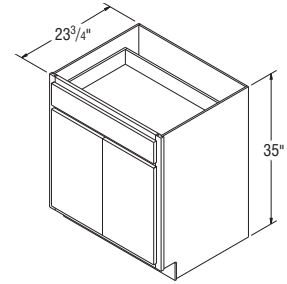

**B27B** FX  
**B30B** FX  
**B33B** FX  
**B36B** FX

NOTES ✓

- ▶ All Roll Tray cabinets include one half-depth fixed 1/2" thick shelf.
- ▶ Roll Trays feature 1/2" thick solid wood front and furniture board sides and back.
- ▶ Additional Roll Trays on page 162 may be ordered separately (TKIT).
- ▶ Upgrade charges do not include Roll Trays.
- ▶ For Roll Tray Bumper Pads, please refer to page 163.



Base Cabinets with Roll Tray, 35" High, 23 3/4" Deep

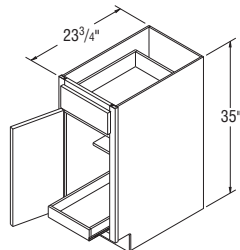

**B15RT** FX **B21RT** FX  
**B18RT** FX **B24RT** FX

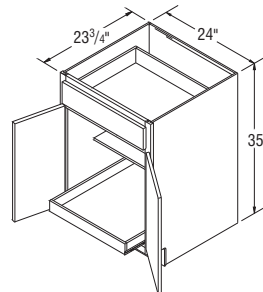

**B24DDRT** FX

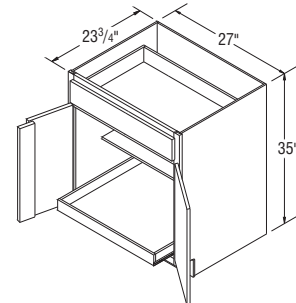

**B27RT** FX

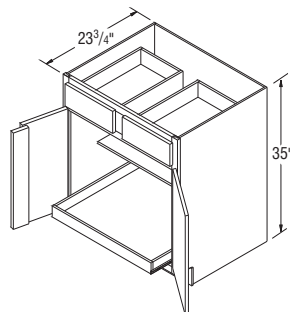

**B30RT** FX  
**B33RT** FX  
**B36RT** FX

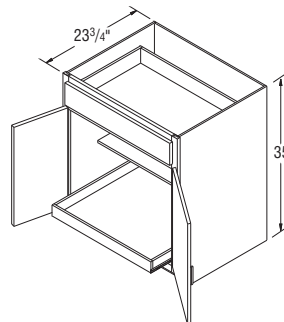

**B27RTB** FX  
**B30RTB** FX  
**B33RTB** FX  
**B36RTB** FX

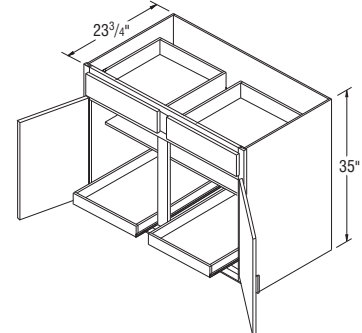

**B39RT** FX  
**B42RT** FX  
**B45RT** FX  
**B48RT** FX

## Base Cabinets with Double Roll Trays, 35" High, 23 3/4" Deep

### NOTES ✓

- ▶ Roll Trays feature 1/2" thick solid wood front and furniture board sides and back.
- ▶ Additional Roll Trays on page 162 may be ordered separately (TKIT).
- ▶ Upgrade charges do not include Roll Trays.
- ▶ For Roll Tray Bumper Pads, please refer to page 163.

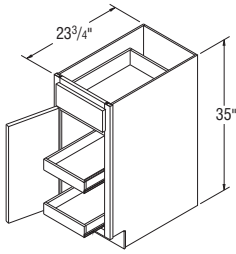

**B15RT-2** FX **B21RT-2** FX  
**B18RT-2** FX **B24RT-2** FX

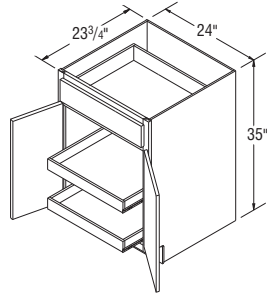

**B24DDRT-2** FX

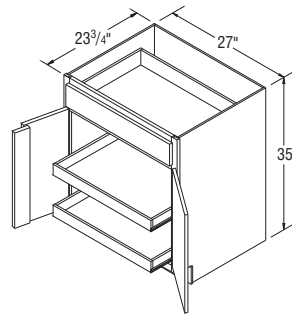

**B27RT-2** FX

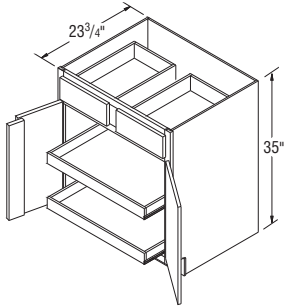

**B30RT-2** FX  
**B33RT-2** FX  
**B36RT-2** FX

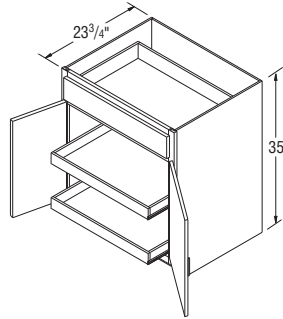

**B27RT-2B** FX  
**B30RT-2B** FX  
**B33RT-2B** FX  
**B36RT-2B** FX

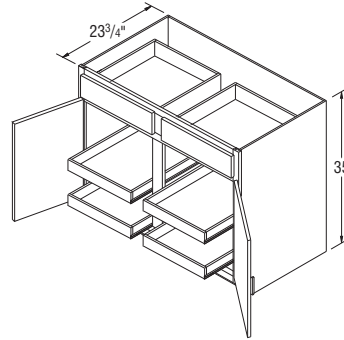

**B39RT-2** FX  
**B42RT-2** FX  
**B45RT-2** FX  
**B48RT-2** FX

## Base Cabinets with Double Roll Trays and Lid Organizer, 35" High, 30" Wide, 23 3/4" Deep

### NOTES ✓

- ▶ Includes removable Pots and Pans Lid Organizer. Lid Organizer is attached to the Roll Tray with two screws for shipping purposes only. Screws should be removed during installation to make the Lid Organizer mobile.
- ▶ Additional Roll Trays on page 162 may be ordered separately (TKIT).
- ▶ Upgrade charges do not include Roll Trays.
- ▶ For Roll Tray Bumper Pads, please refer to page 163.

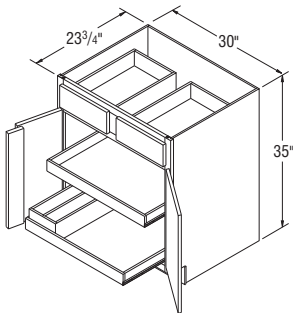

**B30RT-2LO** FX

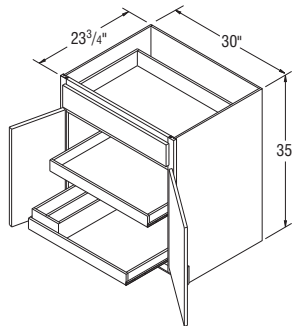

**B30RT-2LOB** FX

**NOTES** ✓

- ▶ SuperCabinet™ doors open 170° to allow sufficient pullout clearance. When installing a SuperCabinet™ near a wall or corner, please allow 12" of adjacent space for proper operation of interior pullouts.
- ▶ Roll Trays are solid wood dovetail boxes with Full Extension side-mounted guides.
- ▶ Upgrade charges do not include Roll Trays.
- ▶ Both doors will have a chrome and wood three-tiered rack that is 3 3/8" deep.
- ▶ Includes cabinet top.



**Base SuperCabinets™, 35" High, 30" Wide, 23 3/4" Deep (Pullout/Roll Out)**

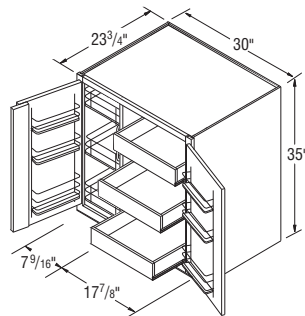

**BSC30PR**

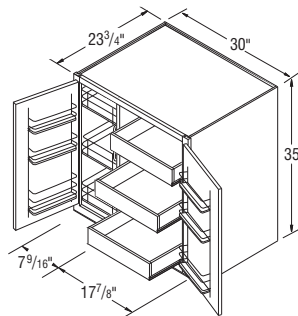

**BSC30PRB**

**NOTES** ✓

- ▶ SuperCabinet™ doors open 170° to allow sufficient pullout clearance. When installing a SuperCabinet™ near a wall or corner, please allow 12" of adjacent space for proper operation of interior pullouts.
- ▶ Roll Trays are solid wood dovetail boxes with Full Extension side-mounted guides.
- ▶ Upgrade charges do not include Roll Trays.
- ▶ Both doors will have a chrome and wood three-tiered rack that is 3 3/8" deep.
- ▶ Includes cabinet top.



**Base SuperCabinets™, 35" High, 30" Wide, 23 3/4" Deep (Roll Out/Pullout)**

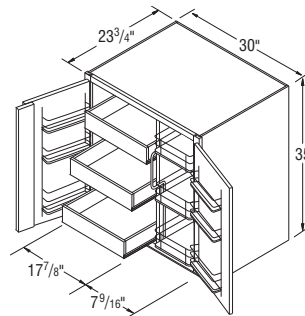

**BSC30RP**

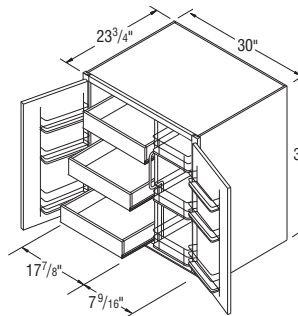

**BSC30RPB**

**NOTES** ✓

- ▶ SuperCabinet™ doors open 170° to allow sufficient pullout clearance. When installing a SuperCabinet™ near a wall or corner, please allow 12" of adjacent space for proper operation of interior pullouts.
- ▶ Roll Trays are solid wood dovetail boxes with Full Extension side-mounted guides.
- ▶ Upgrade charges do not include Roll Trays.
- ▶ Both doors will have a chrome and wood three-tiered rack that is 3 3/8" deep.
- ▶ Includes cabinet top.



**Base SuperCabinets™, 35" High, 36" Wide, 23 3/4" Deep (Pullout/Roll Out/Pullout)**

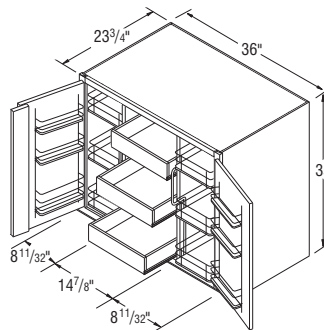

**BSC36PRP**

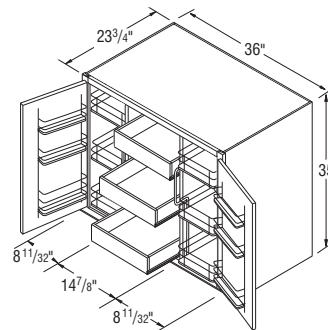

**BSC36PRPB**

## Base Cabinets with Full Height Doors, 35" High, 12" Deep

### NOTES ✓

- ▶ Includes one  $\frac{3}{4}$ " full-depth adjustable shelf.
- ▶ Use with BEC12 (page 92) to transition from standard  $23\frac{3}{4}$ " depth to 12" depth.

### DESIGN SOLUTIONS

- ▶ Use in designs to create varying depths in kitchens, islands, hutches, bookcases, offices, and bathrooms.

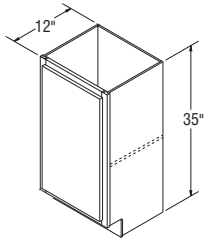

**B12FH-12**  
**B15FH-12**  
**B18FH-12**  
**B21FH-12**  
**B24FH-12**

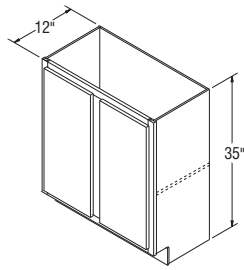

**B30FH-12**  
**B36FH-12**

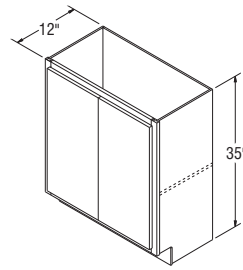

**B30FH-12B**  
**B36FH-12B**

## Base Cabinets with Full Height Doors, 35" High, 23 3/4" Deep

### NOTES ✓

- ▶ Includes one  $\frac{3}{4}$ " full-depth adjustable shelf.

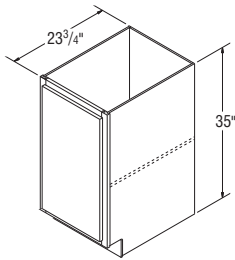

**B12FH**  
**B15FH**  
**B18FH**  
**B21FH**  
**B24FH**

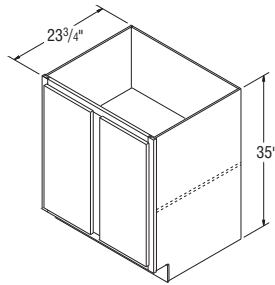

**B30FH**  
**B36FH**

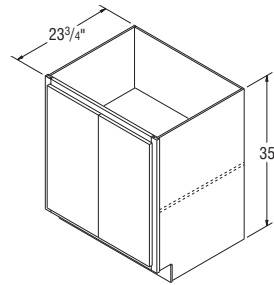

**B30FHB**  
**B36FHB**

## Base Box Column Pullout Cabinet, 30" High, 6" Wide, 23" Deep *New*

### NOTES ✓

- ▶ Features a wood pullout unit with adjustable shelves, chrome rail sides, and Full Extension guides. Filler included, must be attached in the field.
- ▶ Recommend installation between two cabinets. Can be installed on the end of a run by using a  $\frac{3}{4}$ " Refrigerator End Panel.
- ▶ It is recommended that the OL631 Overlay be applied to the front of the BBCP06 to give it a finished look.

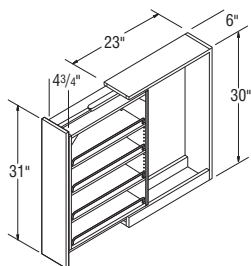

**BBCP06\***

**\* In order to allow sufficient clearance, cabinet requires  $6\frac{1}{8}$ " space between adjacent cabinet face frames. Spacers included for proper installation.**

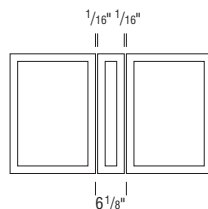

Total space required between face frames



NOTES ✓

- ▶ Features a wood pullout unit with adjustable shelves, chrome rail sides, and Full Extension guides.
- ▶ Nantucket and Grayson BPP09 cabinet doors utilize recessed center panels.



Base Pantry Pullout Cabinet, 35" High, 9" Wide, 23 3/4" Deep

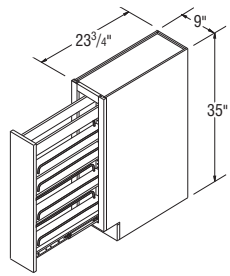

**BPP09**

NOTES ✓

- ▶ Natural finish wood tray divider has three compartments with removable dividers. Divider operates on side-mount guides.



Base Cabinet with Roll Out Tray Divider, 35" High, 12" Wide, 23 3/4" Deep

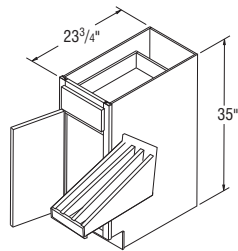

**B12TDRO FX**

NOTES ✓

- ▶ Cabinets include matching Aristex® interior.
- ▶ Includes one 3/4" thick full-depth adjustable shelf.

Base Open Cabinets, 35" High, 12" Deep *New*

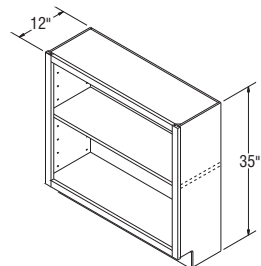

**BOL2412**  
**BOL3012**  
**BOL3612**

## Base Open Cabinets, 35" High, 15" Deep *New*

### NOTES ✓

- ▶ Cabinets include matching Aristex® interior.
- ▶ Includes one ¾" thick full-depth adjustable shelf.

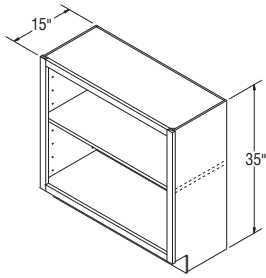

**BOL2415**  
**BOL3015**  
**BOL3615**

## Base Pots and Pans Pullout, 35" High, 24" Wide, 23 ¾" Deep

### NOTES ✓

- ▶ Full Extension slide out shelves pull out independently.

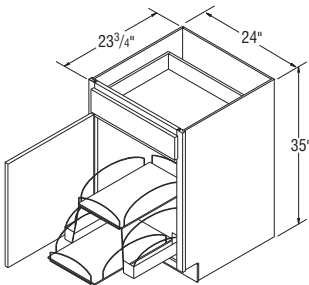

**BPPP24 FX**



## Base Wastebasket with Full Height Door, 35" High, 23 ¾" Deep

### NOTES ✓

- ▶ BWB15FH has one 50-quart wastebasket and small storage tray on Full Extension guides.
- ▶ Natural maple wastebasket support.

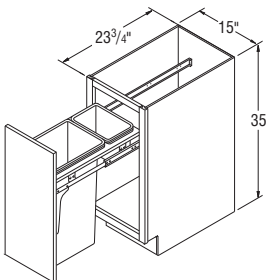

**BWB15FH**



NOTES ✓

- ▶ BWB18 and BWB21 have two 35-quart pullout wastebaskets on Full Extension guides.
- ▶ Natural maple wastebasket support.



Base Wastebaskets, 35" High, 23 3/4" Deep

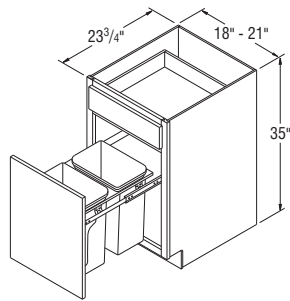

**BWB18** <sup>FX</sup>  
**BWB21** <sup>FX</sup>

NOTES ✓

- ▶ FP = False Panel.
- ▶ It may be necessary to modify the corner braces/stretcher rails with some sink applications.
- ▶ Shelves not included.
- ▶ Front-Onlys are not available in Sink Bases.

Sink/Range Bases, 35" High, 23 3/4" Deep

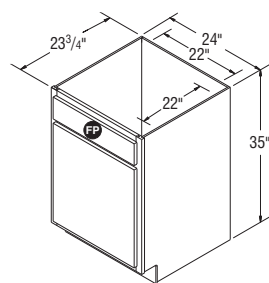

**SB24**

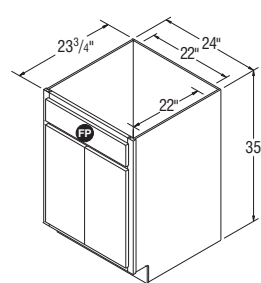

**SB24DD**

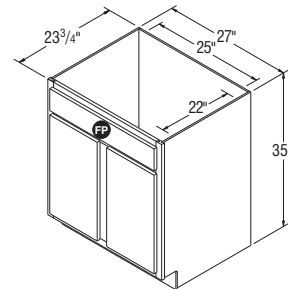

**SB27**

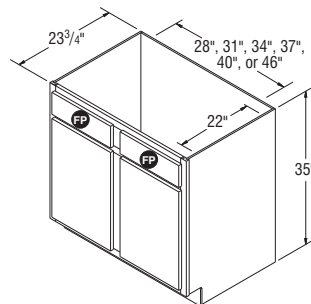

**SB30 SB42**  
**SB33 SB45**  
**SB36 SB48**  
**SB39**

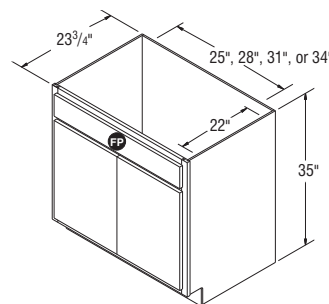

**SB27B**  
**SB30B**  
**SB33B**  
**SB36B**

## Sink Base SuperCabinets™ with Reversible Shelf, 35" High, 23 3/4" Deep

### NOTES ✓

- ▶ Reversible Shelf is constructed from 3/4" thick laminated furniture board. Shelf shipped secure, can be positioned in left or right corner.
- ▶ Both doors will have a chrome and wood two-tiered rack that is 3 1/4" deep.
- ▶ Includes two installed tip-out trays.
- ▶ Quarter round shelf will be natural maple laminate for all styles, including White styles.

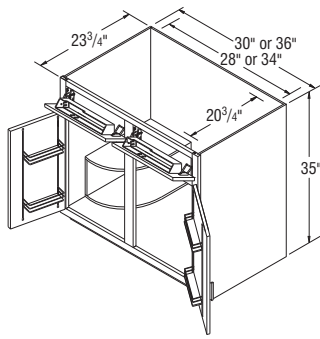

**SB30STS**  
**SB36STS**

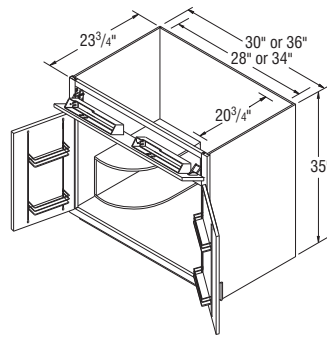

**SB30STSB**  
**SB36STSB**



## Sink Base SuperCabinets™, 35" High, 23 3/4" Deep

### NOTES ✓

- ▶ Both doors will have a chrome and wood two-tiered rack that is 3 1/4" deep.
- ▶ Includes two installed tip-out trays.

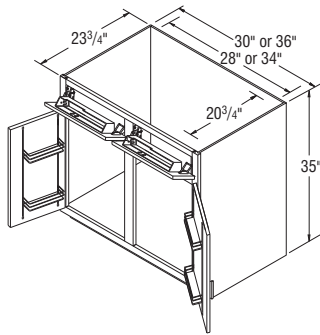

**SB30STNS**  
**SB36STNS**

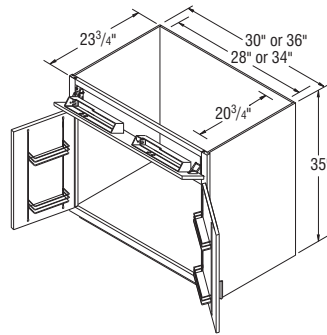

**SB30STNSB**  
**SB36STNSB**



## Country Sink Bases, 35" High, 23 3/4" Deep

### NOTES ✓

- ▶ It may be necessary to modify the corner braces/stretcher rails with some sink applications.

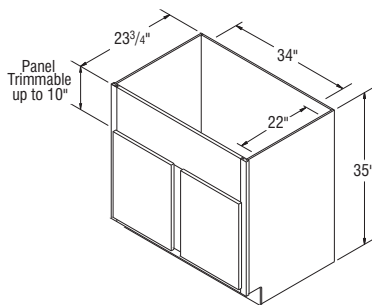

**CNTYSB36**

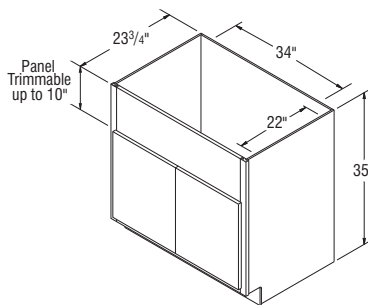

**CNTYSB36B**

## Sink Base Diagonal Corner Cabinets, 35" High, 23 3/4" Deep

**NOTES** ✓

- ▶ FP = False Panel.
- ▶ For sufficient dishwasher door clearance and loading/unloading space, a 15" wide base cabinet is recommended for use between sink base diagonal corner cabinet and dishwasher.

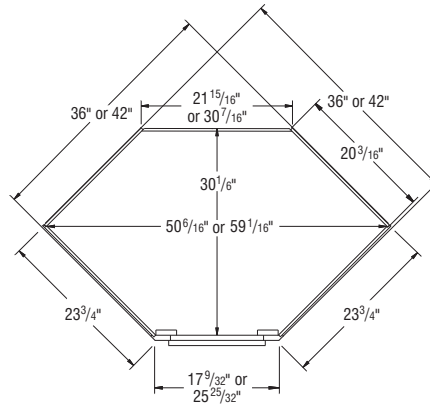
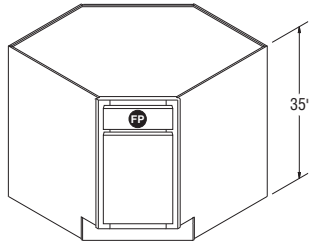

**SBDC36**  
**SBDC42**

TOP VIEW

	Wall Width	Max. Sink Width
SBDC36	36" x 36"	25 3/4"
SBDC42	42" x 42"	34 1/4"

**NOTES** ✓

- ▶ Sink Base floor included with all units.
- ▶ Trimmable 3" each side on partial overlay styles. Not trimmable on full overlay styles.

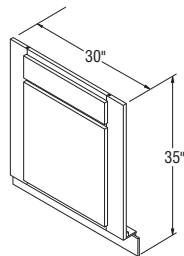

PARTIAL OVERLAY

**SF30**  
**SF36**

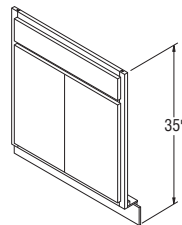

FULL OVERLAY

**SF30B**  
**SF36B**

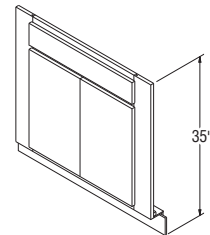

PARTIAL OVERLAY

**SF36B**  
**SF42B**

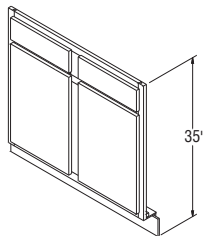

FULL OVERLAY

**SF42**  
**SF48**

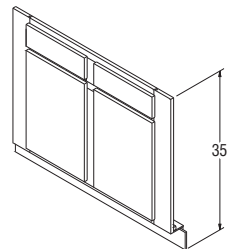

PARTIAL OVERLAY

**SF36**  
**SF48**

## Sink/Range Fronts, 35" High

## Sink Front Corners, 35" High

NOTES ✓

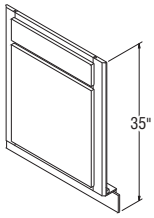

**SFC36**  
**SFC42**

- ▶ Sink Base floor included with all units.
- ▶ Toekick is not attached, ships loose.
- ▶ For sufficient dishwasher door clearance and loading/unloading space, a 15" wide base cabinet is recommended for use between sink base diagonal corner cabinet and dishwasher.
- ▶ Floor dimensions:  
SFC36 –  $\frac{3}{8}$ " x 36" x 36".  
SFC42 –  $\frac{3}{8}$ " x 42" x 42".

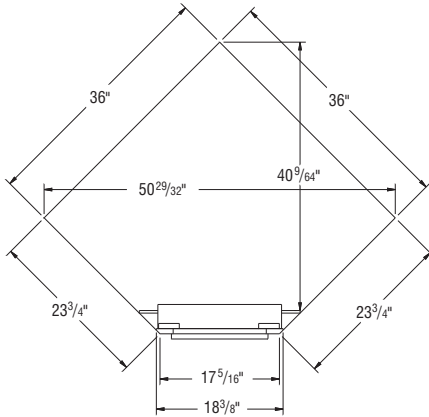

SFC36  
TOP VIEW

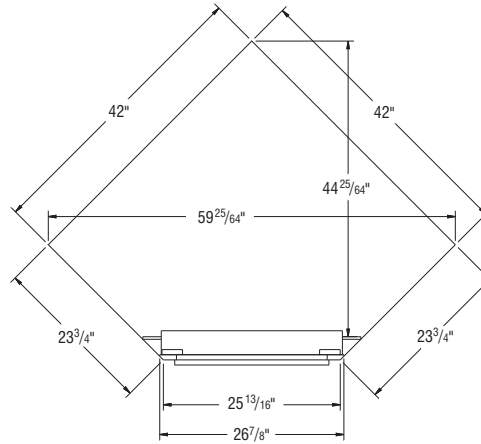

SFC42  
TOP VIEW

	Wall Width	Max. Sink Width
SFC36	36" x 36"	25 3/4"
SFC42	42" x 42"	34 1/4"

## Four Drawer Bases, 35" High, 23 3/4" Deep

NOTES ✓

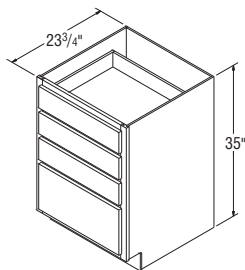

**DB12-4** FX  
**DB15-4** FX  
**DB18-4** FX  
**DB21-4** FX  
**DB24-4** FX  
**DB27-4** FX  
**DB30-4** FX \*  
**DB33-4** FX \*  
**DB36-4** FX \*

- ▶ Removable plastic Cutlery Tray included in top drawer of DB15-4 to DB24-4.
- ▶ DB36-4 is recommended for use with Pegged Dish Organizer (PDO) on page 157. PDO can also be trimmed to fit smaller widths.
- ★ Standard construction features side-mount Full Extension guides on bottom drawer. Does not feature Smart Stop™. **Select** construction and **APC** feature undermount Full Extension Smart Stop™ guides on bottom drawer. **FX upgrade** features undermount Full Extension Smart Stop™ guides on all four drawers.

NOTES ✓

- ▶ Removable plastic Cutlery Tray included in top drawer of DB15 to DB24.
- ▶ DB36 is recommended for use with Pegged Dish Organizer (PDO) on page 157. PDO can also be trimmed to fit smaller widths.
- ★ Standard construction features side-mount Full Extension guides on bottom two drawers. Does not feature Smart Stop™. **Select** construction and **APC** feature undermount Full Extension Smart Stop™ guides on bottom two drawers. **FX upgrade** features undermount Full Extension Smart Stop™ guides on all three drawers.

Three Drawer Bases, 35" High, 23 3/4" Deep

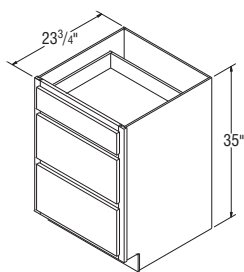

- DB12** <sup>FX</sup>
- DB15** <sup>FX</sup>
- DB18** <sup>FX</sup>
- DB21** <sup>FX</sup>
- DB24** <sup>FX</sup>
- DB27** <sup>FX</sup>
- DB30** <sup>FX</sup> ★
- DB33** <sup>FX</sup> ★
- DB36** <sup>FX</sup> ★

NOTES ✓

- ▶ DBFP36 is recommended for use with Pegged Dish Organizer (PDO) on page 157. PDO can also be trimmed to fit DBFP30-4.
- ▶ Standard construction features side-mount Full Extension guides on bottom drawer. Does not feature Smart Stop™. **Select** construction and **APC** feature undermount Full Extension Smart Stop™ guides on bottom drawer. **FX upgrade** features undermount Full Extension Smart Stop™ guides on all three drawers.

Four Drawer Bases with False Panel, 35" High, 23 3/4" Deep

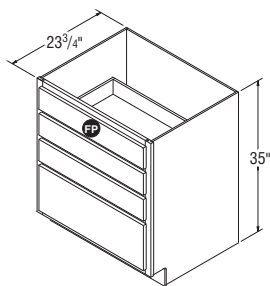

- DBFP30-4** <sup>FX</sup>
- DBFP36-4** <sup>FX</sup>

NOTES ✓

- ▶ DBFP36 is recommended for use with Pegged Dish Organizer (PDO) on page 157. PDO can also be trimmed to fit DBFP30.
- ▶ Standard construction features side-mount Full Extension guides on bottom drawers. Does not feature Smart Stop™. **Select** construction and **APC** feature undermount Full Extension Smart Stop™ guides on bottom drawers.

Three Drawer Bases with False Panel, 35" High, 23 3/4" Deep

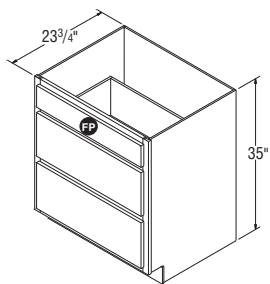

- DBFP30**
- DBFP36**

## Base Built-In Microwave Cabinet, 35" High, 23 3/4" Deep

### NOTES ✓

- ▶ Microwave opening is trimmable.
- ▶ Minimum opening – 27" W x 17" H. Maximum opening – 28 1/2" W x 21" H.
- ▶ Designed for Built-in Microwaves with trim kits (cabinet has standard Aristex® natural maple or white interior).

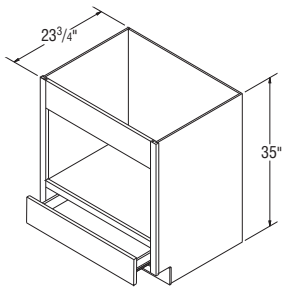

**BMW3035 FX**

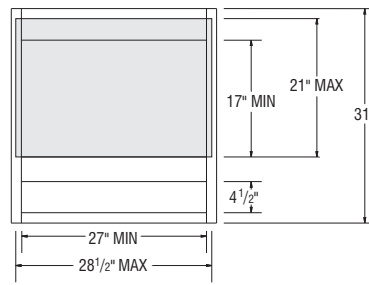

TRIM AREA



## Square Corner/Base Roto Easy Reach Cabinets, 35" High, 23 3/4" Deep

### NOTES ✓

- ▶ One piano-hinged door.
- ▶ Includes magnetic catch.
- ▶ Cannot convert SCER36 to BRER.
- ▶ BRER36 includes two 28" diameter rotating plastic white trays. Each tray has a 60 lb. load capacity
- ▶ BRER: WARNING! The rotating trays in this cabinet are preinstalled and cannot be removed or replaced. Do not stand on, or apply excessive pressure that could cause a tray to crack or break.
- ▶ Decorative hardware must be countersunk to prevent scratching of adjacent cabinets and face frame of SCER/BRER.

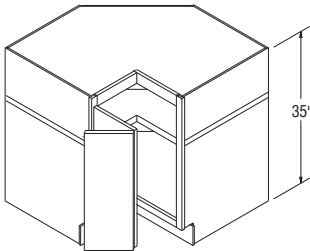

**SCER36\***

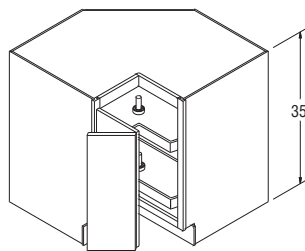

**BRER36\***

\*Specify L or R for full overly styles.

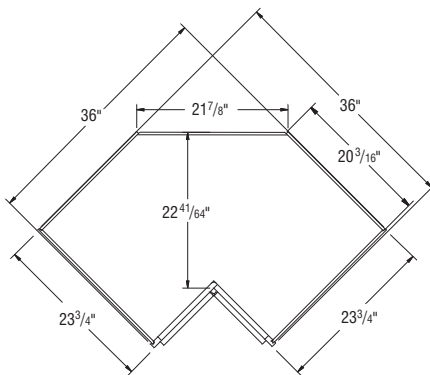

TOP VIEW



Square Corner Rotos, 35" High

NOTES ✓

- ▶ One rotating door.
- ▶ Two rotating white shelves.
- ▶ Nominal gap of 1/4" on all sides of door.
- ▶ SCR33 has 17" diameter shelf and holds 20 lbs. per shelf.
- ▶ SCR36 has 27" diameter shelf and holds 60 lbs. per shelf.
- ▶ APC charges do not apply to SCR cabinets.

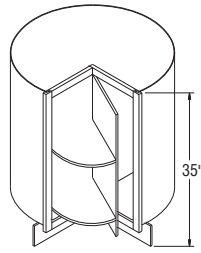

SCR33  
SCR36

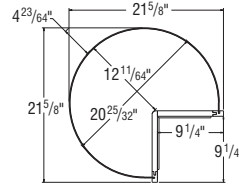

SCR33  
TOP VIEW

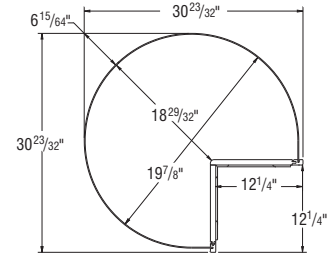

SCR36  
TOP VIEW

NOTES ✓

- ▶ One piano-hinged door...
- ▶ Includes magnetic catch.
- ▶ BLS33 has two 17" diameter rotating plastic white shelves that hold 20 lbs. per shelf.
- ▶ BLS36 has two 27" diameter rotating plastic white shelves that hold 60 lbs. per shelf.
- ▶ Grayson and Nantucket BLS33 doors utilize recessed center panels.
- ▶ APC charges do not apply to BLS cabinets.



Base Lazy Susans, 35" High

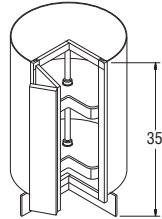

BLS33\*

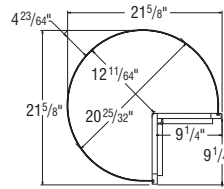

BLS33  
TOP VIEW

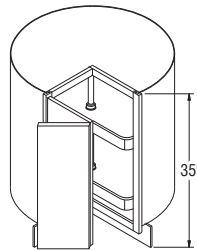

BLS36\*

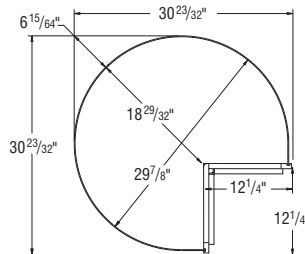

BLS36  
TOP VIEW

\*Specify L or R for full overlay styles.

## Square Corner Bases, 35" High, 23 3/4" Deep

### NOTES

- ▶ One door and one drawer.
- ▶ Half-depth fixed shelf included.
- ▶ All Square Corner Base cabinets are reversible from left blind to right blind.
- ▶ 3" Filler is included with all Square Corner Base cabinets and shipped under Toekick or in cabinet. Briarcliff II, Dryden, Durham, Eastland, Nantucket, Overton, and Wentworth styles come with F331 and OL31.
- ▶ To ensure proper door/drawer clearance, we recommend you do not install appliances next to the blind.
- ▶ Cover panel included for field installation to cover blind opening.

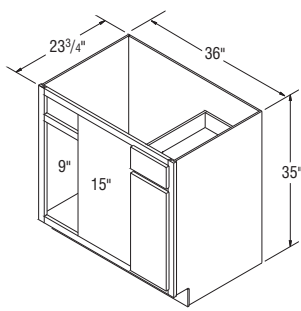

**SCB36 FX**

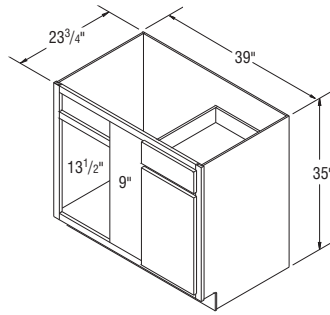

**SCB39 FX**

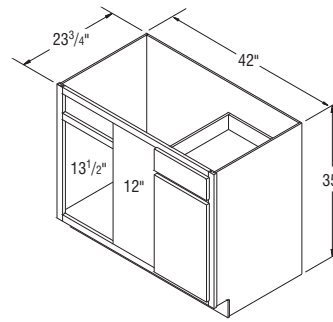

**SCB42 FX**

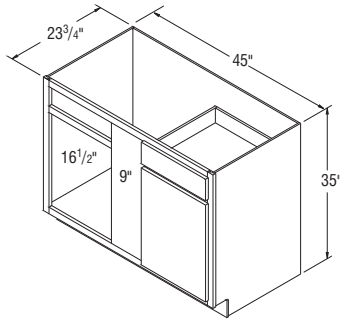

**SCB45 FX**

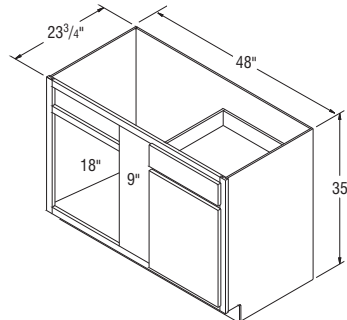

**SCB48 FX**

## Square Corner Cabinet Information

### KEY

- X: Minimum pull for Square Corner cabinets.
- Y: Maximum pull for Square Corner cabinets.
- Z: Minimum filler size required between cabinets.
- ▶ Minimum pull figured when Square Corner Wall or adjacent cabinet doors can open 90 degrees.

Full Overlay Styles	X		Y	Z	
	Min. Pull	Min. Pull w/Hardware	Max. Pull	Min. Filler Required	Min. Filler Required w/Hardware
<b>SCB36</b>	3/4"	2 1/4"	12 1/2"	1"	2 1/2"
<b>SCB39</b>	2 1/4"	3 3/4"	8"	1"	2 1/2"
<b>SCB42</b>	0"	3/4"	8"	1"	2 1/2"
<b>SCB45</b>	0"	3/4"	5"	1"	2 1/2"
<b>SCB48</b>	0"	0"	3 1/2"	1"	2 1/2"

7/16" Overlay Styles	X		Y	Z	
	Min. Pull	Min. Pull w/Hardware	Max. Pull	Min. Filler Required	Min. Filler Required w/Hardware
<b>SCB36</b>	1/4"	1 3/4"	12 1/2"	1/2"	2"
<b>SCB39</b>	1 3/4"	3 1/4"	8"	1/2"	2"
<b>SCB42</b>	0"	1/4"	8"	1/2"	2"
<b>SCB45</b>	0"	1/4"	5"	1/2"	2"
<b>SCB48</b>	0"	0"	3 1/2"	1/2"	2"

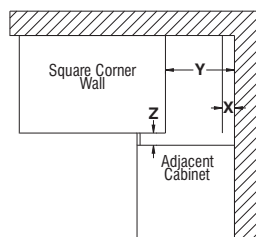

NOTES ✓

- ▶ Two doors.
- ▶ One fixed shelf.
- ▶ Not designed for stand alone island applications.
- ▶ Standard and Select have laminate, non-matching sides.
- ▶ APC sides are unfinished.



Base End Cabinet, 35" High, 23 3/4" Deep

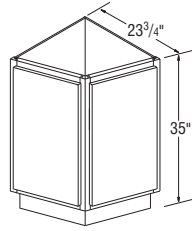

**BECF24**

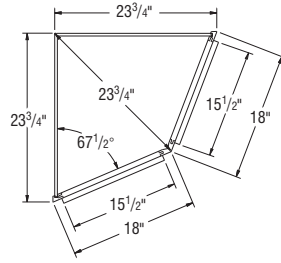

TOP VIEW

NOTES ✓

- ▶ Includes one 12" deep fixed shelf.
- ▶ 23 3/4" side is unfinished in APC only.



Base End Cabinet, 35" High, 12" Wide, 23 3/4" Deep

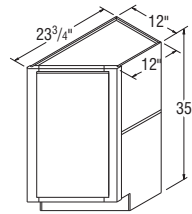

**BEC12\***



BEC12R  
TOP VIEW

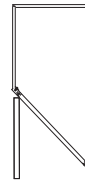

BEC12L  
TOP VIEW

\*L or R designation specifies 12" deep side and door hinging.

## Peninsula Base Cabinets, 35" High, 23 3/4" Deep

### NOTES ✓

- ▶ Reversible units with one full-depth, 3/4" thick, plywood fixed shelf in all construction platforms.
- ▶ Peninsula cabinets not designed to be used as stand alone island cabinets.
- ▶ PB18 and PB24 have two doors, one drawer, and one drawer front.
- ▶ PB24DD has four doors, one drawer, and one drawer front.
- ▶ PB30-PB48 have four doors, two drawers, and two drawer fronts.
- ▶ PB30B-PB36B have four doors (two sets of butt doors), one drawer, and one drawer front.

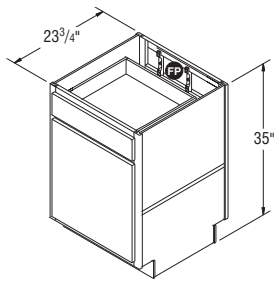

**PB18** FX  
**PB24** FX

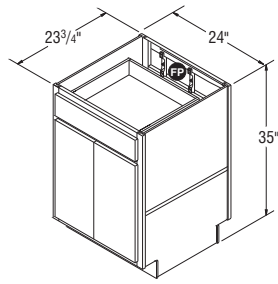

**PB24DD** FX

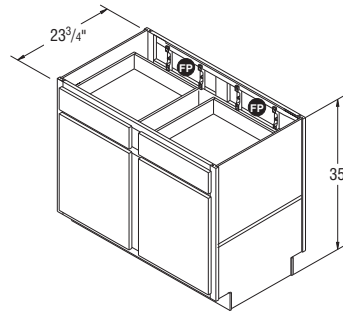

**PB30** FX  
**PB36** FX  
**PB42** FX  
**PB48** FX

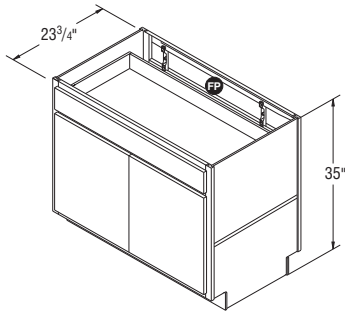

**PB30B** FX  
**PB36B** FX

BASE CABINETS | PENINSULA

## Peninsula Base Square Corner Cabinets, 35" High, 23 3/4" Deep

### NOTES ✓

- ▶ 3" Filler is included.
- ▶ Reversible units with one full-depth fixed shelf.
- ▶ Peninsula cabinets not designed to be used as stand alone island cabinets.
- ▶ Cover panel included for field installation.

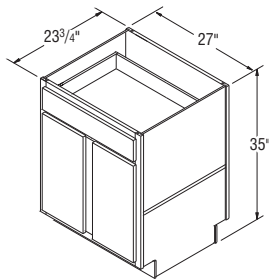

BACK VIEW  
**PBSC27** FX

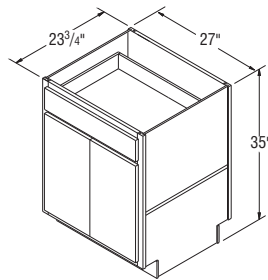

BACK VIEW  
**PBSC27B** FX

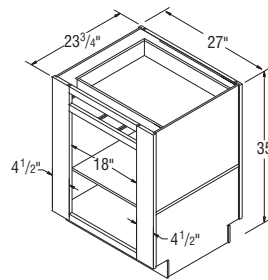

FRONT VIEW  
**PBSC27**

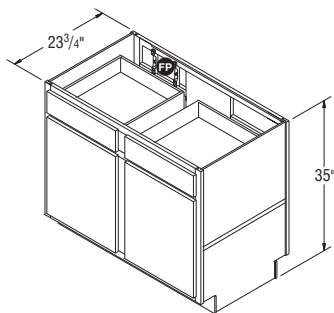

BACK VIEW  
**PBSC42** FX  
**PBSC48** FX

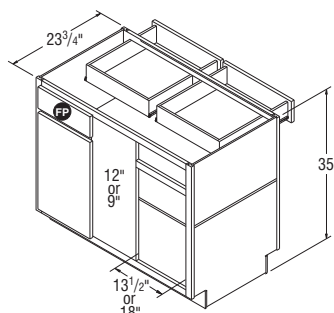

FRONT VIEW  
**PBSC42** FX  
**PBSC48** FX

## Square Corner Base Cabinet Information

**KEY**

- X: Minimum pull for Square Corner cabinets.
- Y: Maximum pull for Square Corner cabinets.
- Z: Minimum filler size required between cabinets.
- ▶ Minimum pull figured when Square Corner Wall or adjacent cabinet doors can open 90 degrees.

Full Overlay Styles	X		Y	Z	
	Min. Pull	Min. Pull w/Hardware	Max. Pull	Min. Filler Required	Min. Filler Required w/Hardware
<b>PBSC27</b>	0"	0"	1/2"	1"	2 1/2"
<b>PBSC42</b>	0"	3/4"	8"	1"	2 1/2"
<b>PBSC48</b>	0"	0"	3 1/2"	1"	2 1/2"

7/16" Overlay Styles	X		Y	Z	
	Min. Pull	Min. Pull w/Hardware	Max. Pull	Min. Filler Required	Min. Filler Required w/Hardware
<b>PBSC27</b>	0"	0"	1/2"	1/2"	2"
<b>PBSC42</b>	0"	1/4"	8"	1/2"	2"
<b>PBSC48</b>	0"	0"	3 1/2"	1/2"	2"

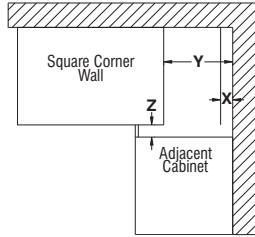

# Oven Cabinets, 84" High, 23 3/4" Deep

## NOTES ✓

- ▶ Two doors and three drawers.
- ▶ Oven shelf support kit included.
- ▶ For OCINSTALLKIT, see page 160.

## DESIGN SOLUTIONS

- ▶ Be sure to confirm a heat shield is built into your appliance by the manufacturer or install the heat shield included with your appliance.
- ▶ Oven cabinets are trimmable to accommodate a variety of appliance sizes.

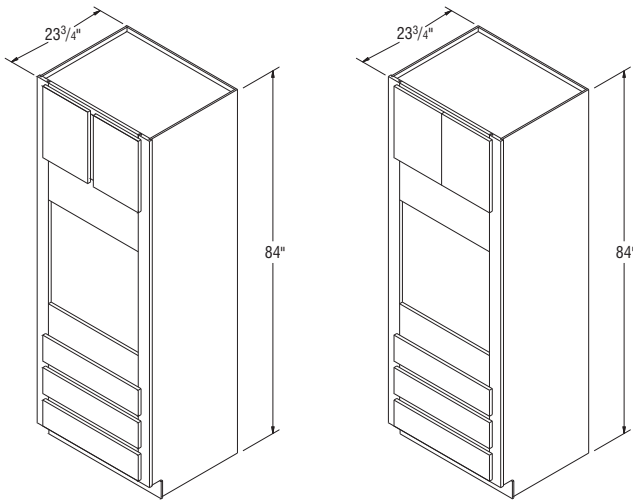

**OC30 FX**  
**OC33 FX**

**OC30B FX**  
**OC33B FX**

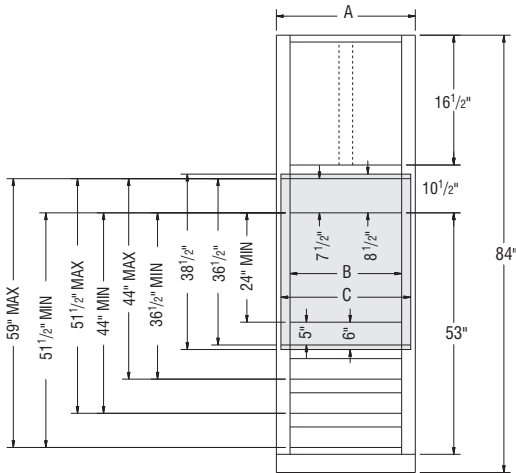

Center Mullion (shown with dotted line above) not applicable on butt door cabinets.

A	B	C
Cabinet Width	Min. Opening	Max. Opening
30"	24"	28 1/2"
33"	27"	31 1/2"

**NOTES** ✓

- ▶ Two doors and three drawers.
- ▶ All 90" cabinets are shipped as an 86" cabinet with 4" toekick sub-assembly unattached.
- ▶ Oven shelf support kit included.
- ▶ For OCINSTALLKIT, see page 160.

**DESIGN SOLUTIONS**

- ▶ Be sure to confirm a heat shield is built into your appliance by the manufacturer or install the heat shield included with your appliance.
- ▶ Oven cabinets are trimmable to accommodate a variety of appliance sizes.

Oven Cabinets, 90" High, 23 3/4" Deep

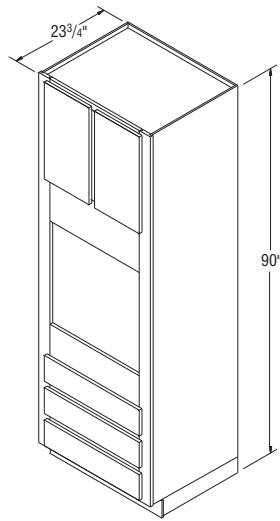

**OC3090 FX**  
**OC3390 FX**

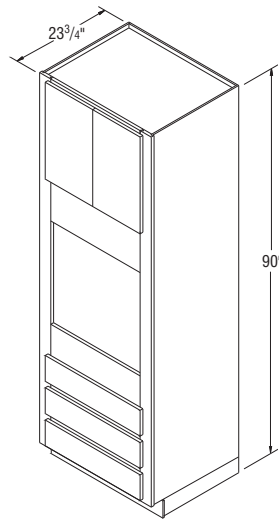

**OC3090B FX**  
**OC3390B FX**

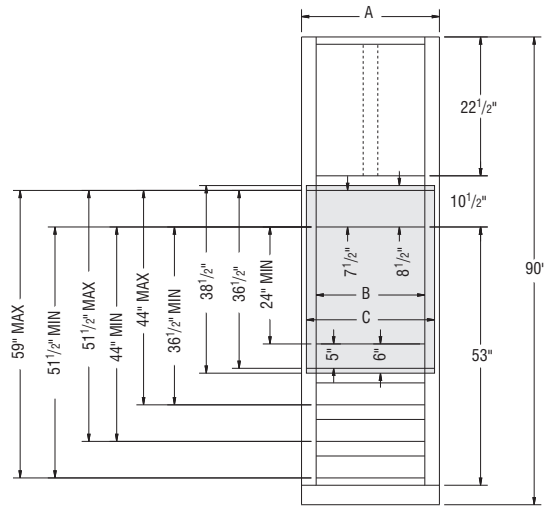

Center Mullion (shown with dotted line above) not applicable on butt door cabinets.

A Cabinet Width	B Min. Opening	C Max. Opening
30"	24"	28 1/2"
33"	27"	31 1/2"

# Oven Cabinets, 96" High, 23 3/4" Deep

## NOTES ✓

- ▶ Two doors, one adjustable shelf, and three drawers.
- ▶ All 96" cabinets are shipped as a 92" cabinet with 4" Toekick sub-assembly unattached.
- ▶ Oven shelf support kit included.
- ▶ For OCINSTALLKIT, see page 160.

## DESIGN SOLUTIONS

- ▶ Be sure to confirm a heat shield is built into your appliance by the manufacturer or install the heat shield included with your appliance.
- ▶ Oven cabinets are trimmable to accommodate a variety of appliance sizes.

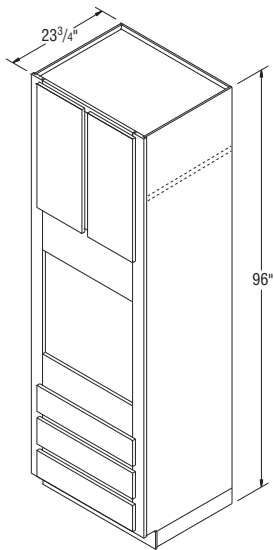

**OC3096** FX  
**OC3396** FX

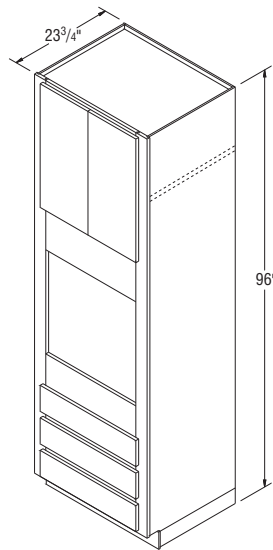

**OC3096B** FX  
**OC3396B** FX

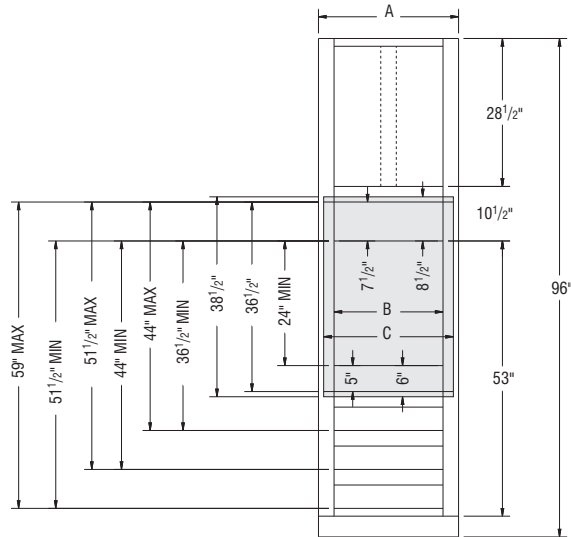

Center Mullion (shown with dotted line above) not applicable on butt door cabinets.

A Cabinet Width	B Min. Opening	C Max. Opening
30"	24"	28 1/2"
33"	27"	31 1/2"

# Oven Cabinets Double, 84" High, 23 3/4" Deep

**NOTES** ✓

- ▶ Two doors and one drawer.
- ▶ Oven shelf support kit included.
- ▶ For OCDINSTALLKIT, see page 160.

**DESIGN SOLUTIONS**

- ▶ Be sure to confirm a heat shield is built into your appliance by the manufacturer or install the heat shield included with your appliance.
- ▶ Oven cabinets are trimmable to accommodate a variety of appliance sizes.

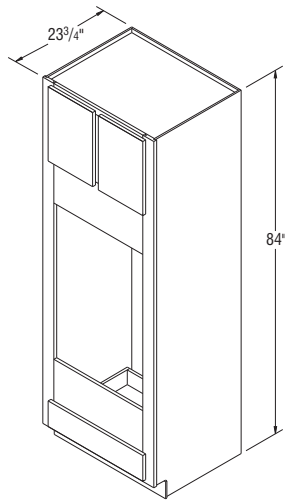

**OCD30** FX  
**OCD33** FX

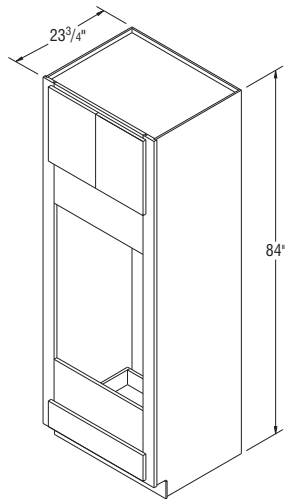

**OCD30B** FX  
**OCD33B** FX

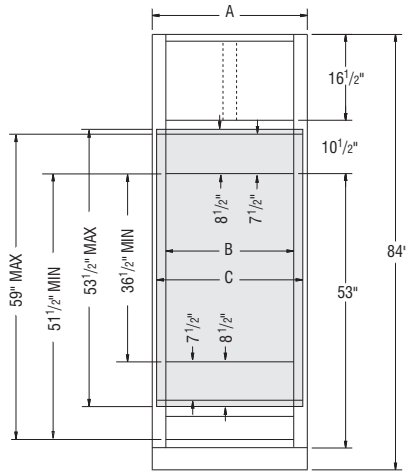

Center Mullion (shown with dotted line above) not applicable on butt door cabinets.

<b>A</b> Cabinet Width	<b>B</b> Min. Opening	<b>C</b> Max. Opening
30"	24"	28 1/2"
33"	27"	31 1/2"

# Oven Cabinets Double, 90" High, 23 3/4" Deep

## NOTES ✓

- ▶ Two doors and one drawer.
- ▶ All 90" cabinets are shipped as an 86" cabinet with 4" Toekick sub-assembly unattached.
- ▶ Oven shelf support kit included.
- ▶ For OCDINSTALLKIT, see page 160.

## DESIGN SOLUTIONS

- ▶ Be sure to confirm a heat shield is built into your appliance by the manufacturer or install the heat shield included with your appliance.
- ▶ Oven cabinets are trimmable to accommodate a variety of appliance sizes.

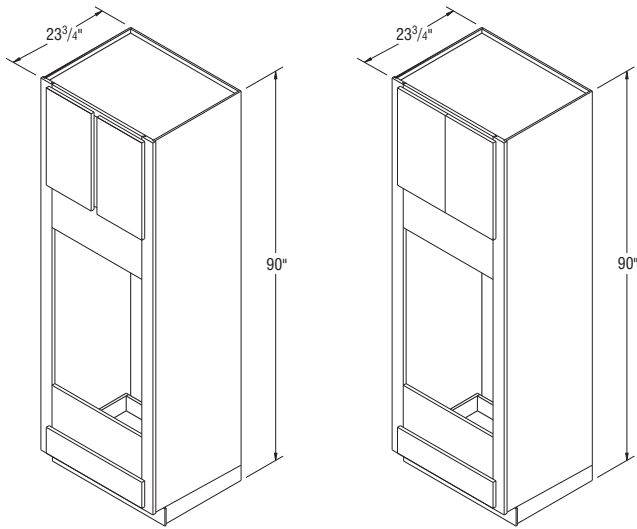

**OCD3090 FX**  
**OCD3390 FX**

**OCD3090B FX**  
**OCD3390B FX**

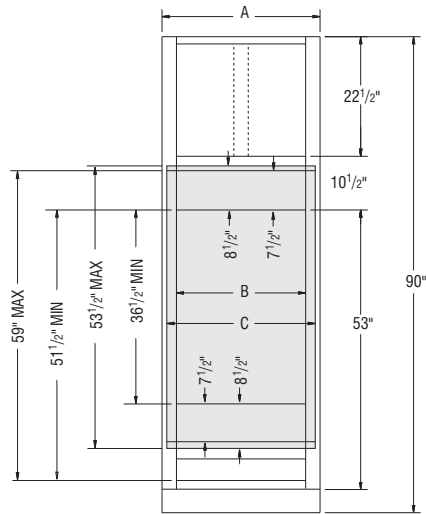

Center Mullion (shown with dotted line above) not applicable on butt door cabinets.

<b>A</b> Cabinet Width	<b>B</b> Min. Opening	<b>C</b> Max. Opening
30"	24"	28 1/2"
33"	27"	31 1/2"

**NOTES** ✓

- ▶ Two doors, one adjustable shelf, and one drawer.
- ▶ All 96" cabinets are shipped as a 92" cabinet with 4" Toekick sub-assembly unattached.
- ▶ Oven shelf support kit included.
- ▶ For OCINSTALLKIT, see page 160.

**DESIGN SOLUTIONS**

- ▶ Be sure to confirm a heat shield is built into your appliance by the manufacturer or install the heat shield included with your appliance.
- ▶ Oven cabinets are trimmable to accommodate a variety of appliance sizes.

Oven Cabinets Double, 96" High, 23 3/4" Deep

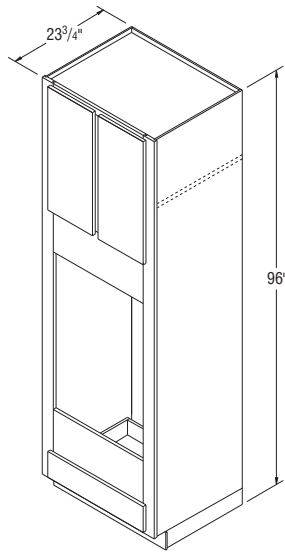

**OCD3096 FX**  
**OCD3396 FX**

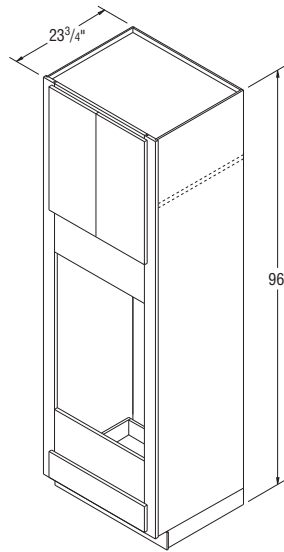

**OCD3096B FX**  
**OCD3396B FX**

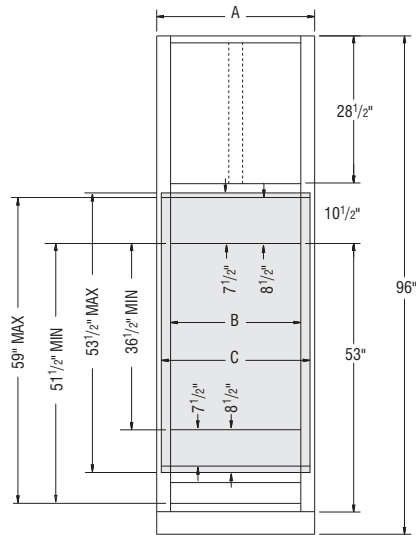

Center Mullion (shown with dotted line above) not applicable on butt door cabinets.

<b>A</b> Cabinet Width	<b>B</b> Min. Opening	<b>C</b> Max. Opening
30"	24"	28 1/2"
33"	27"	31 1/2"

# Pantry SuperCabinets™, 84" High, 23 3/4" Deep

## NOTES ✓

- ▶ Two reduced depth 3/4" thick adjustable shelves in top section.
- ▶ Each upper door features two adjustable height door racks.
- ▶ Four adjustable height roll trays in bottom section.
- ▶ Upgrade charges do not include Roll Trays.
- ▶ Large openings on miter styles will be two doors doweled together.
- ▶ Center mullion is attached to the left door on PSC30 and PSC36.

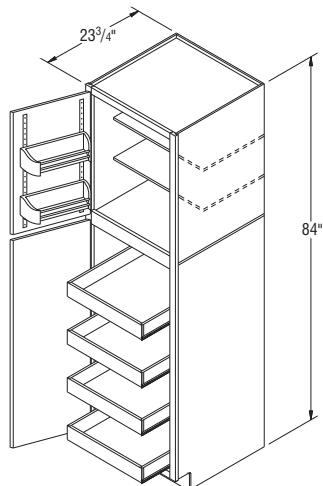

**PSC15\***  
**PSC18\***  
**PSC24\***

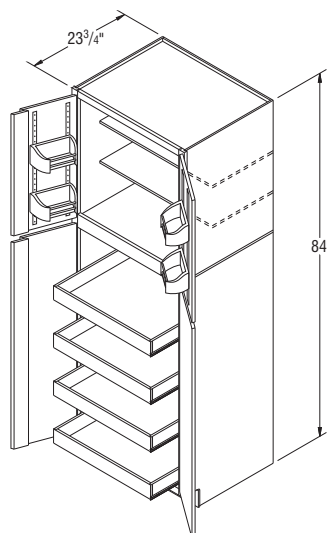

**PSC30**  
**PSC36**

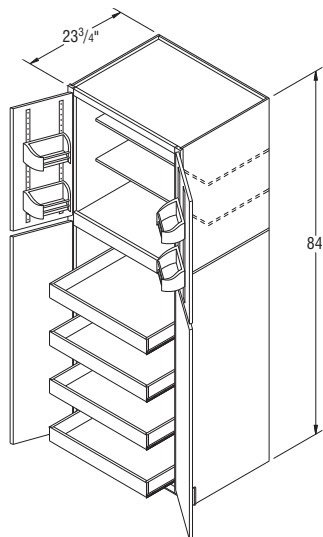

**PSC30B**  
**PSC36B**

\*Specify L or R on all single door Pantry SuperCabinets.

NOTES ✓

- ▶ Two reduced depth 3/4" thick adjustable shelves in top section.
- ▶ Each upper door features two adjustable height door racks.
- ▶ Four adjustable height roll trays in bottom section.
- ▶ All 90" Pantry SuperCabinets™ are shipped as a 86" cabinet with 4" Toekick sub-assembly.
- ▶ Upgrade charges do not include Roll Trays.
- ▶ Large openings on miter styles will be two doors doweled together.
- ▶ Center mullion is attached to the left door on PSC3090 and PSC3690.



Pantry SuperCabinets™, 90" High, 23 3/4" Deep

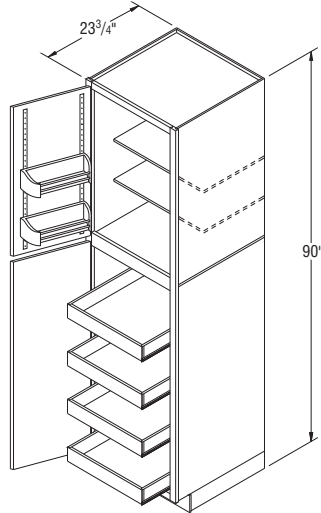

**PSC1590\***  
**PSC1890\***  
**PSC2490\***

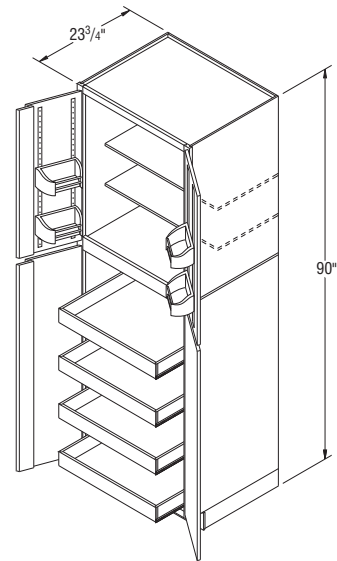

**PSC3090**  
**PSC3690**

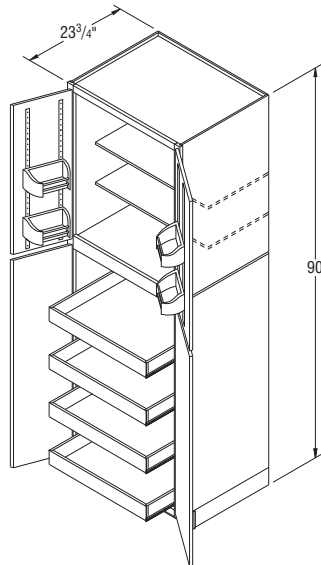

**PSC3090B**  
**PSC3690B**

\*Specify L or R on all single door Pantry SuperCabinets.

# Pantry SuperCabinets™, 96" High, 23 3/4" Deep

## NOTES ✓

- ▶ Two reduced depth 3/4" thick adjustable shelves in top section.
- ▶ Each upper door features two adjustable height door racks.
- ▶ Four adjustable height roll trays in bottom section.
- ▶ All 96" Pantry SuperCabinets™ are shipped as a 92" cabinet with 4" Toekick sub-assembly.
- ▶ Upgrade charges do not include Roll Trays.
- ▶ Large openings on miter styles will be two doors doweled together.
- ▶ Center mullion is attached to the left door on PSC3096 and PSC3696.

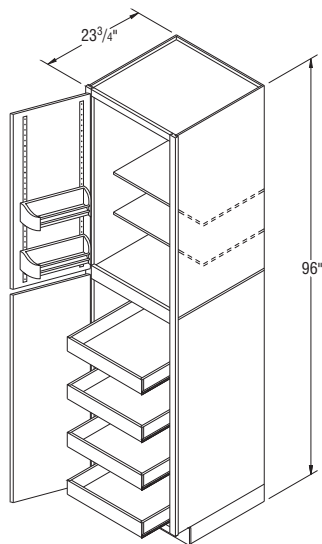

**PSC1596\***  
**PSC1896\***  
**PSC2496\***

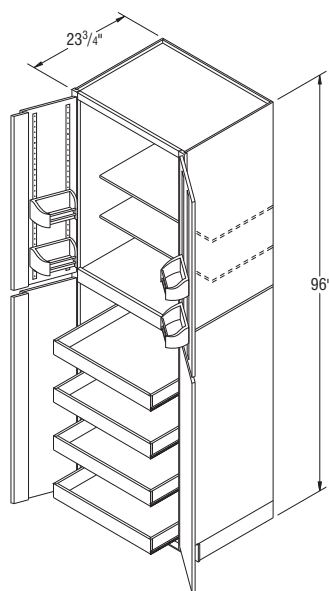

**PSC3096**  
**PSC3696**

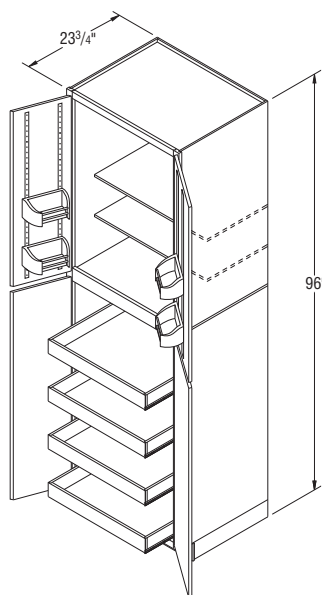

**PSC3096B**  
**PSC3696B**

\*Specify L or R on all single door Pantry SuperCabinets.

**NOTES** ✓

- ▶ 84" high Utility cabinets include one fixed shelf between doors and two ¾" thick adjustable shelves included in 15", 18", and 24" wide Utility cabinets.
- ▶ Large openings on miter styles will be two doors doweled together.
- ▶ Shelves not included on 30" and 36" wide Utility cabinets. For shelf and Roll Tray options see pages 161-162.
- ▶ Center mullion is attached to the left door on U30, U36, U3012, and U3612.



**Utility Cabinets, 84" High, 12" and 23 ¾" Deep**

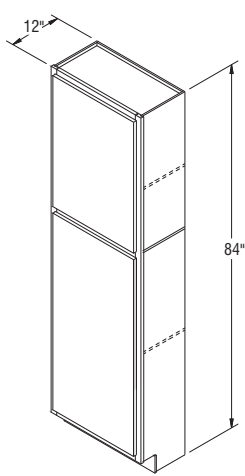

**U1512\***  
**U1812\***  
**U2412\***

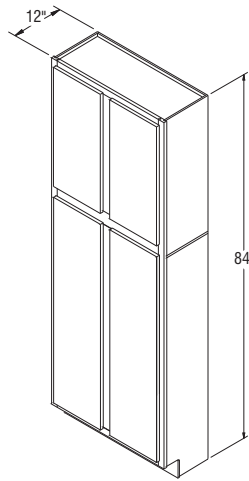

**U3012**  
**U3612**

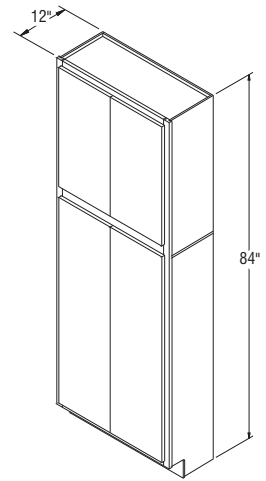

**U3012B**  
**U3612B**

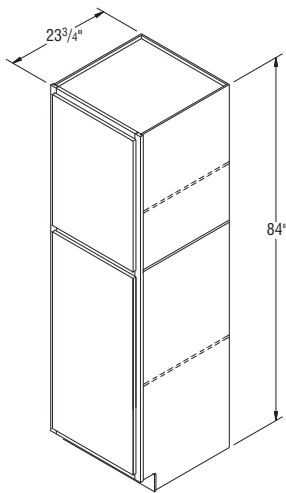

**U15\***  
**U18\***  
**U24\***

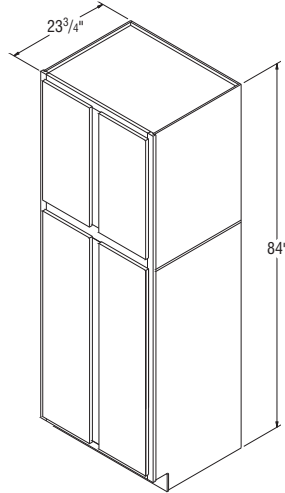

**U30**  
**U36**

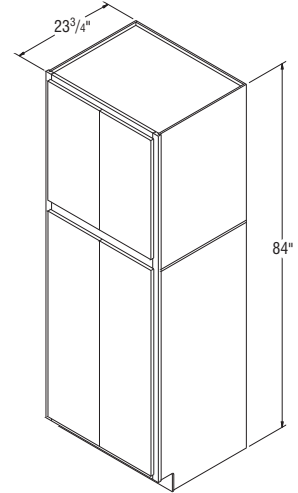

**U30B**  
**U36B**

\*Specify L or R on all single door Utility Cabinets.

# Utility Cabinets, 90" High, 12" and 23 3/4" Deep

## NOTES ✓

- ▶ All 90" high Utility cabinets are shipped as an 86" cabinet with 4" Toekick sub-assembly.
- ▶ 90" high Utility cabinets include one fixed shelf between doors and three 3/4" thick adjustable shelves included in 15", 18", and 24" wide Utility cabinets.
- ▶ Large openings on miter styles will be two doors doweled together.
- ▶ Shelves not included on 30" and 36" wide Utility cabinets. For shelf and Roll Tray options see pages 161-162.
- ▶ Center mullion is attached to the left door on U3090, U3690, U309012, and U369012.

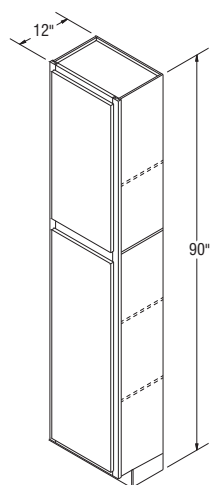

**U159012\***  
**U189012\***  
**U249012\***

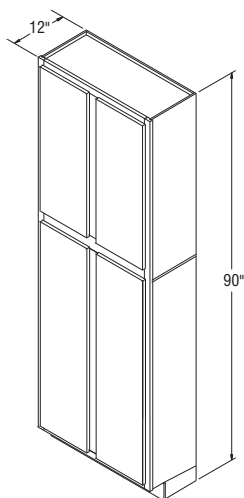

**U309012**  
**U369012**

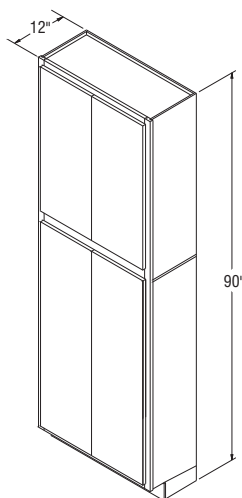

**U309012B**  
**U369012B**

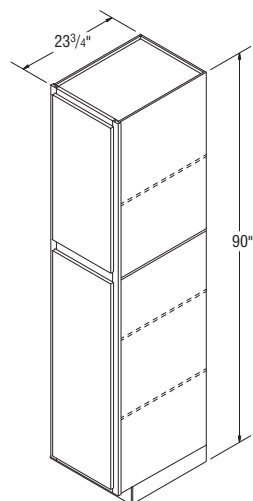

**U1590\***  
**U1890\***  
**U2490\***

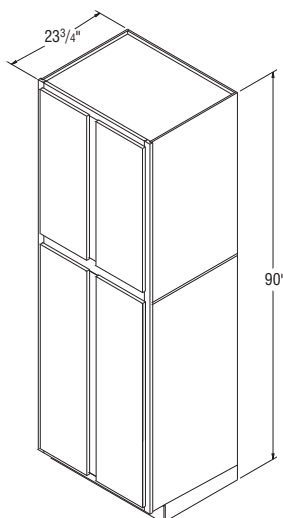

**U3090**  
**U3690**

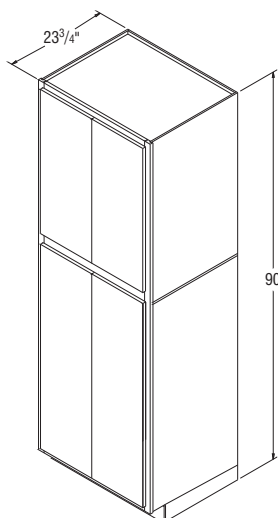

**U3090B**  
**U3690B**

\*Specify L or R on all single door Utility Cabinets.

**NOTES** ✓

- ▶ All 96" Utility cabinets are shipped as a 92" cabinet with 4" Toekick sub-assembly.
- ▶ 96" high Utility cabinets include one fixed shelf between doors and three ¾" thick adjustable shelves included in 15", 18", and 24" wide Utility cabinets.
- ▶ Shelves not included on 30" and 36" wide Utility cabinets. For shelf and Roll Tray options see pages 161-162.
- ▶ Large openings on miter styles will be two doors doweled together.
- ▶ Center mullion is attached to the left door on U3096, U3696, U309612, and U369612.



**Utility Cabinets, 96" High, 12" and 23 ¾" Deep**

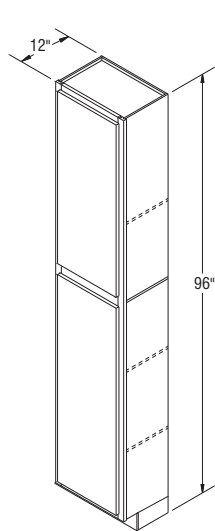

**U159612\***  
**U189612\***  
**U249612\***

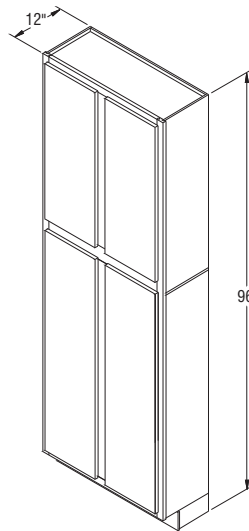

**U309612**  
**U369612**

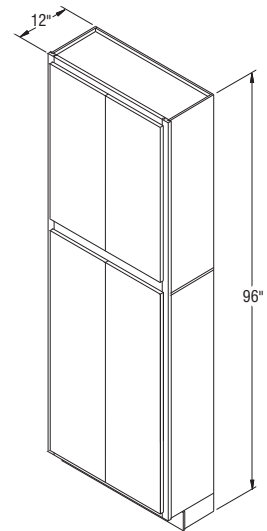

**U309612B**  
**U369612B**

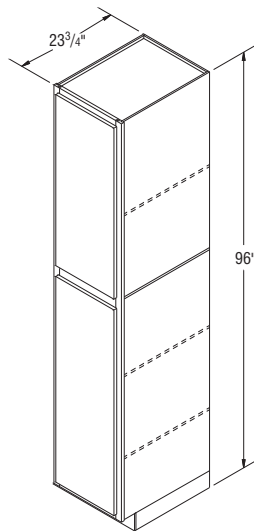

**U1596\***  
**U1896\***  
**U2496\***

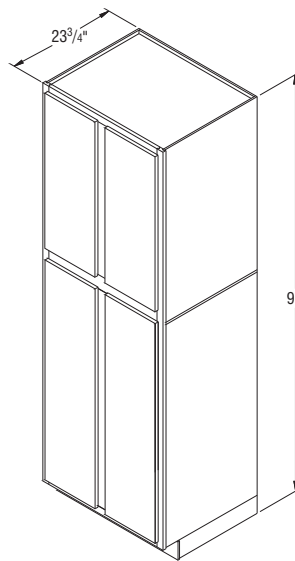

**U3096**  
**U3696**

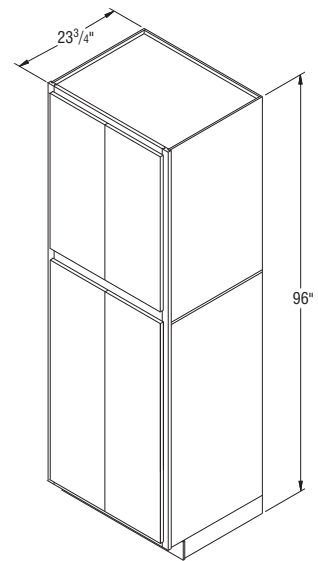

**U3096B**  
**U3696B**

\*Specify L or R on all single door Utility Cabinets.

## Bookcases, 52 1/2" High, 12" Deep

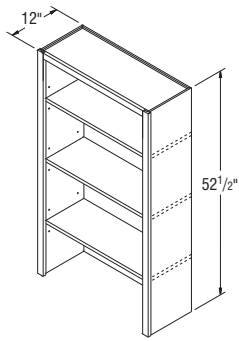

**BK2452.5**  
**BK3052.5**  
**BK3652.5**

### NOTES ✓

- ▶ Includes three 3/4" thick veneer shelves.
- ▶ Matching Aristex® interior.
- ▶ Designed to mount on the Bookcase Base cabinet with countertop.
- ▶ For loads on shelves over 60 lbs., Aristokraft recommends the use of the Bookshelf Kit on page 154.

## Bookcases, 64 1/2" High, 12" Deep

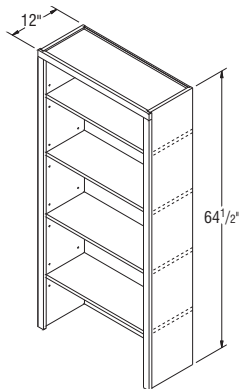

**BK2464.5**  
**BK3064.5**  
**BK3664.5**

### NOTES ✓

- ▶ Includes four 3/4" thick veneer shelves.
- ▶ Matching Aristex® interior.
- ▶ Designed to mount on the Bookcase Base cabinet with countertop.
- ▶ For loads on shelves over 60 lbs., Aristokraft recommends the use of the Bookshelf Kit on page 154.

## Bookcases, 84" High, 12" Deep

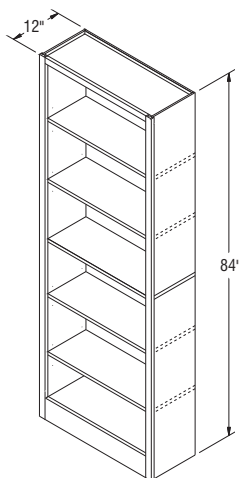

**BK3084**  
**BK3684**

### NOTES ✓

- ▶ Includes five 3/4" thick veneer shelves — four adjustable and one fixed center shelf.
- ▶ Matching Aristex® interior.
- ▶ Wide bottom rail.
- ▶ For loads on shelves over 60 lbs., Aristokraft recommends the use of the bookshelf Kit on page 154.

**NOTES** ✓

- ▶ Includes one ¾" thick full-depth adjustable shelf.
- ▶ Matching Aristex® interior.
- ▶ Center mullion is attached to the left door on BKB3030 and BKB3630.
- ▶ Does not include countertop.

**Bookcase Bases, 30" High, 21" Deep**

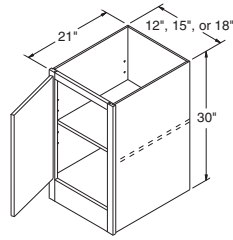

**BKB1230  
BKB1530  
BKB1830**

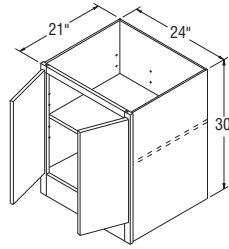

**BKB2430**

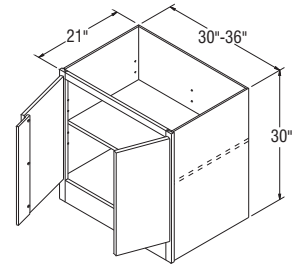

**BKB3030  
BKB3630**

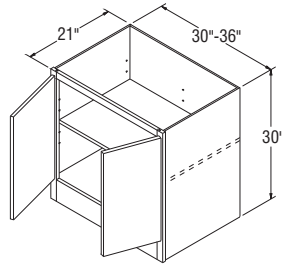

**BKB3030B  
BKB3630B**

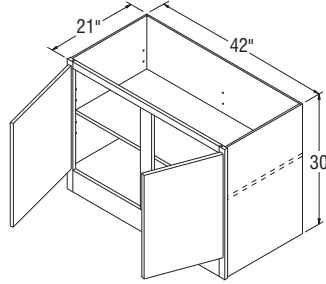

**BKB4230**

**NOTES** ✓

- ▶ Includes two full height drawers with Full Extension guides for all construction options.
- ▶ Includes hanging file system for folders.
- ▶ Includes wide bottom rail, no recessed Toekick.
- ▶ It is recommended that this unit be fastened to the wall when installing.
- ▶ Interior dimension for Standard Construction file drawer is 12<sup>31</sup>/<sub>32</sub>" W x 19" D x 9<sup>5</sup>/<sub>8</sub>" H.
- ▶ Standard Construction accommodates front-to-back and side-to-side filing of letter documents and side-to-side filing of legal documents. Drawer width will not permit front-to-back filing of legal documents.
- ▶ Interior dimension for Select and All Plywood Construction dovetail file drawer is 12<sup>5</sup>/<sub>8</sub>" W x 16<sup>5</sup>/<sub>8</sub>" D x 9<sup>1</sup>/<sub>4</sub>" H.
- ▶ Select and All Plywood Construction accommodates side-to-side filing of legal and letter documents.
- ▶ FX/SmartStop™ upgrade not available on file drawers.

**Vanity File Drawer Base, 30" High, 18" Wide, 21" Deep**

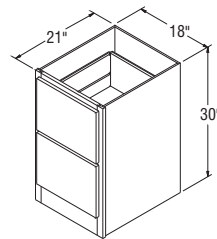

**VFDB18**

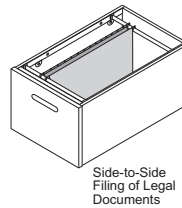

Side-to-Side Filing of Legal Documents

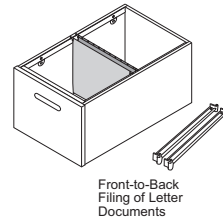

Front-to-Back Filing of Letter Documents

Standard Construction

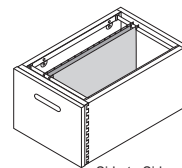

Side-to-Side Filing of Legal Documents

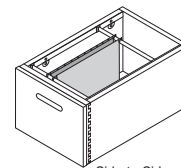

Side-to-Side Filing of Letter Documents

Select & APC

## Vanity File Drawers, 30" High, 21" Deep

### NOTES ✓

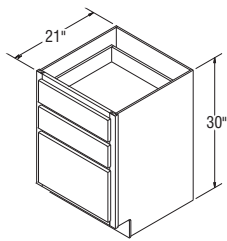

**VFD18 FX**  
**VFD21 FX**

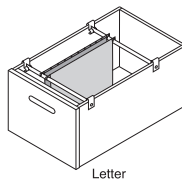
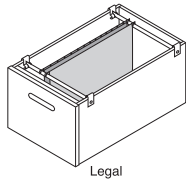

Standard/Select & APC

- ▶ The bottom drawer is deep for standard letter and legal documents and includes two adjustable hanging rods and four hanging clips.
- ▶ Bottom file drawer has  $\frac{3}{4}$ " extension guides. FX is recommended for use with legal documents for sufficient access and removal of folders.
- ▶ Interior dimension for undermount file drawer is:  
VFD18 –  $13\frac{1}{16}$ " W x  $16\frac{5}{8}$ " D x  $9\frac{1}{4}$ " H.  
VFD21 –  $16\frac{1}{16}$ " W x  $16\frac{5}{8}$ " D x  $9\frac{1}{4}$ " H.
- ▶ Interior dimension for standard file drawer is:  
VFD18 –  $12\frac{29}{32}$ " W x 19" D x  $9\frac{5}{8}$ " H.  
VFD21 –  $15\frac{31}{32}$ " W x 19" D x  $9\frac{5}{8}$ " H.

## Keyboard Tray, $4\frac{3}{4}$ " High, 30" Wide, 21" Deep (Trimmable)

### NOTES ✓

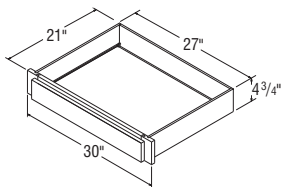

**KTT30**

- ▶ Face frame trimmable 3" overall,  $1\frac{1}{2}$ " on each side.
- ▶ Drawer front flips down for access to keyboard.
- ▶ Briarcliff II, Nantucket, and Wentworth have a slab drawer front.

## Kneespace Drawers, $4\frac{3}{4}$ " High, 21" Deep (Trimmable)

### NOTES ✓

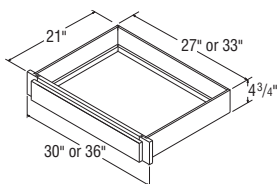

**KDT30 FX**  
**KDT36 FX**

- ▶ Face frame trimmable 3" overall,  $1\frac{1}{2}$ " on each side.
- ▶ Shallow depth drawer.
- ▶ Briarcliff II, Nantucket, and Wentworth have a slab drawer front.
- ▶ Not available in All Plywood Construction.

**NOTES** ✓

- ▶ FP = False Panel.
- ▶ It may be necessary to modify the corner braces/stretcher rails with some sink applications.

**Vanity Console Bases, 30" High, 21" Deep**

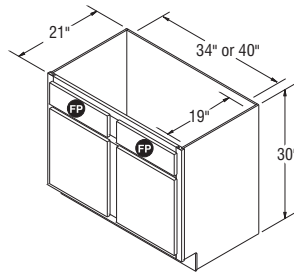

**VCB36**  
**VCB42**

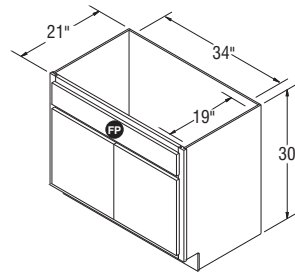

**VCB36B**

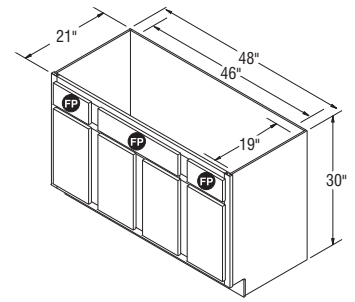

**VCB48**

**NOTES** ✓

- ▶ FP = False Panel.
- ▶ It may be necessary to modify the corner braces/stretcher rails with some sink applications.

**Vanity Console Bases, 35" High, 21" Deep**

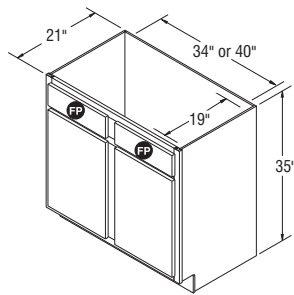

**VCB3635**  
**VCB4235**

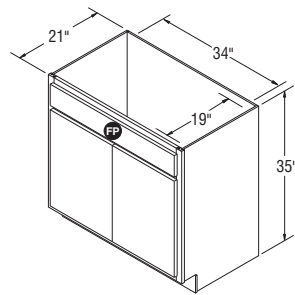

**VCB3635B**

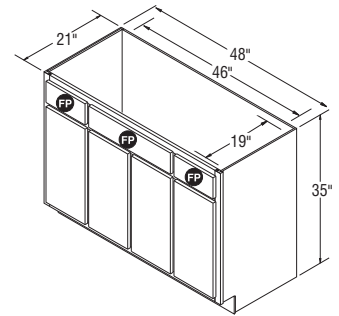

**VCB4835**

**NOTES** ✓

- ▶ Half-depth fixed shelf.
- ▶ 18" deep Vanities available in Standard construction only.

**Vanity Bases, 30" High, 18" Deep**

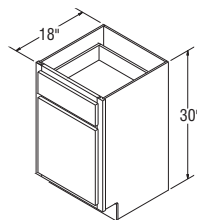

**VB1218**  
**VB1518**  
**VB1818**  
**VB2118**

## Vanity Bases, 30" High, 21" Deep

### NOTES ✓

- ▶ Half-depth fixed shelf.
- ▶ VB24 has butt doors on all door styles.

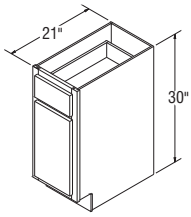

**VB12** <sup>FX</sup>  
**VB15** <sup>FX</sup>  
**VB18** <sup>FX</sup>  
**VB21** <sup>FX</sup>

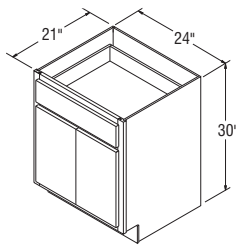

**VB24** <sup>FX</sup>

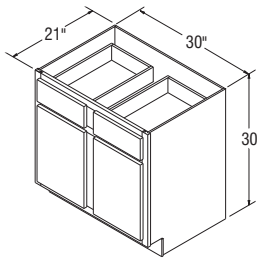

**VB30** <sup>FX</sup>

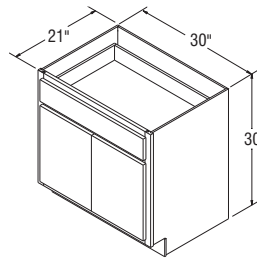

**VB30B** <sup>FX</sup>

## Vanity Bases, 35" High, 21" Deep

### NOTES ✓

- ▶ Half-depth fixed shelf.
- ▶ VB2435 has butt doors on all door styles.

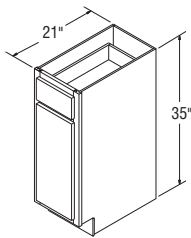

**VB1235** <sup>FX</sup>  
**VB1535** <sup>FX</sup>  
**VB1835** <sup>FX</sup>  
**VB2135** <sup>FX</sup>

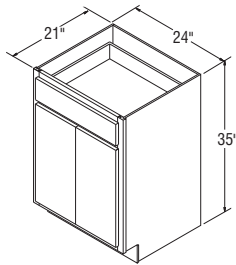

**VB2435** <sup>FX</sup>

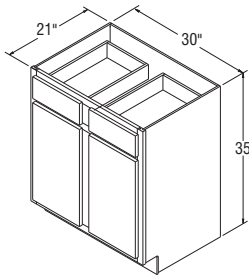

**VB3035** <sup>FX</sup>

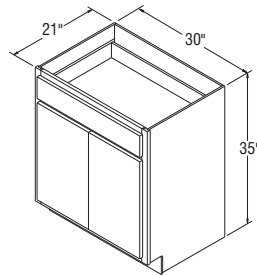

**VB3035B** <sup>FX</sup>

## Vanity Base Pullout, 35" High, 9" Wide, 21" Deep

### NOTES ✓

- ▶ Features a wood pullout unit with adjustable shelves, chrome rail sides, and Full Extension guides.
- ▶ Nantucket and Grayson VBP0935 cabinet doors utilize recessed center panels.

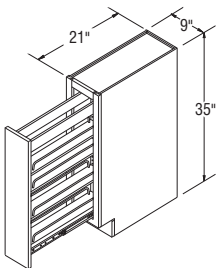

**VBP0935**



**NOTES** ✓

- ▶ FP = False Panel.
- ▶ It may be necessary to modify the corner braces/stretcher rails with some sink applications.
- ▶ 18" deep Vanities available in Standard construction only.

**Vanity Door and Drawer Bases, 30" High, 18" Deep**

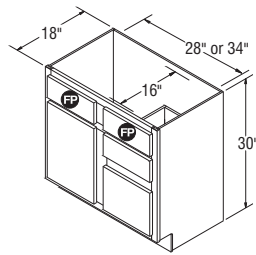
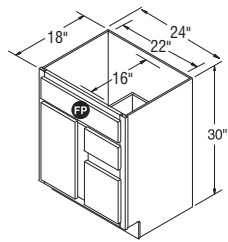

- VDD2418\***
- VDD3018\***
- VDD3618\***

\*Specify L or R for which side to locate door.

**NOTES** ✓

- ▶ FP = False Panel.
- ▶ It may be necessary to modify the corner braces/stretcher rails with some sink applications.

**Vanity Door and Drawer Bases, 30" High, 21" Deep**

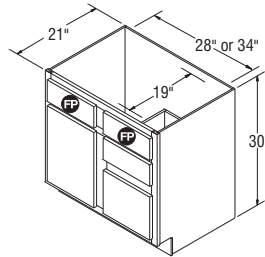
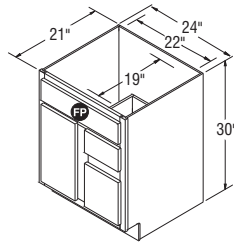

**VDD24 FX \***

**VDD30 FX \***  
**VDD36 FX \***

\*Specify L or R for which side to locate door.

**NOTES** ✓

- ▶ FP = False Panel.
- ▶ It may be necessary to modify the corner braces/stretcher rails with some sink applications.

**Vanity Door and Drawer Bases, 35" High, 21" Deep**

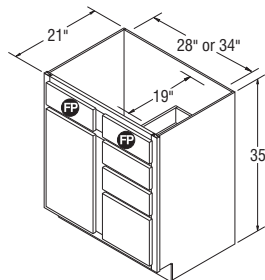
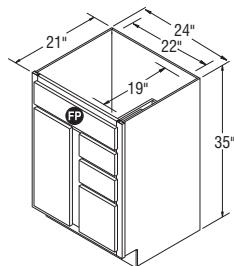

**VDD2435 FX \***

**VDD3035 FX \***  
**VDD3635 FX \***

\*Specify L or R for which side to locate door.

## Vanity Double Drawer Bases, 30" High, 18" Deep

### NOTES ✓

- ▶ FP = False Panel.
- ▶ 18" deep Vanities available in Standard construction only.
- ▶ VDDB4818 has butt doors on all door styles

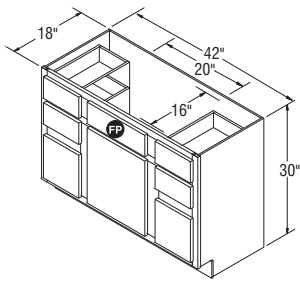

**VDDDB4218**

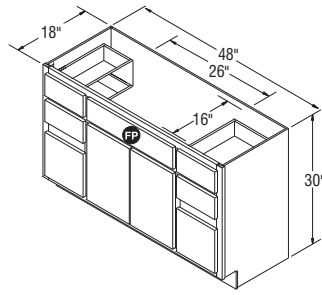

**VDDDB4818**

## Vanity Double Drawer Bases, 30" High, 21" Deep

### NOTES ✓

- ▶ FP = False Panel.
- ▶ VDDDB48 and VDDDB60 have butt doors on all door styles.

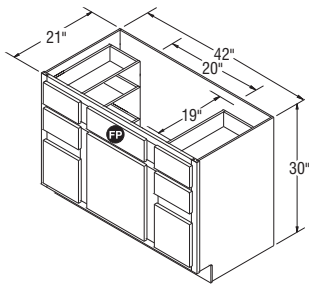

**VDDDB42 FX**

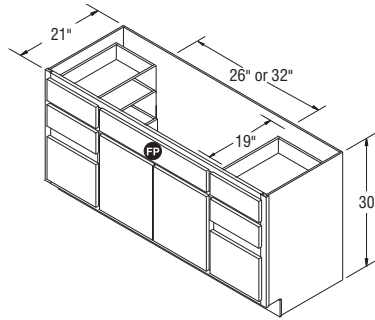

**VDDDB48 FX**  
**VDDDB60 FX**

## Vanity Double Drawer Bases, 35" High, 21" Deep

### NOTES ✓

- ▶ FP = False Panel.
- ▶ VDDDB4835 and VDDDB6035 have butt doors on all door styles.

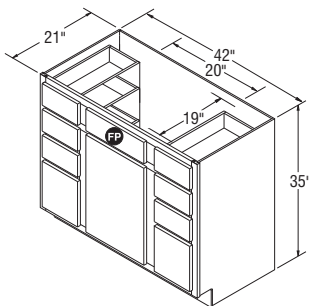

**VDDDB4235 FX**

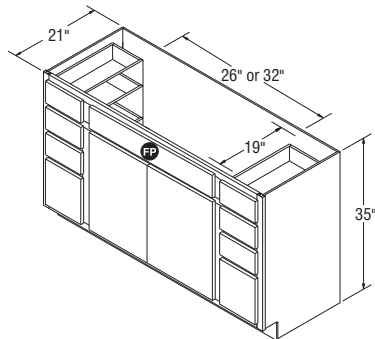

**VDDDB4835 FX**  
**VDDDB6035 FX**

**NOTES** ✓

- ▶ FP = False Panel.
- ▶ Cabinet is 57" wide.
- ▶ Front frame is 60" wide.
- ▶ Front end rails are each 3" and can be trimmed to 1½".
- ▶ VDDBT60 has butt doors on all door styles.

**Trimmable Vanity Double Drawer Base, 30" High, 60" Wide, 21" Deep**

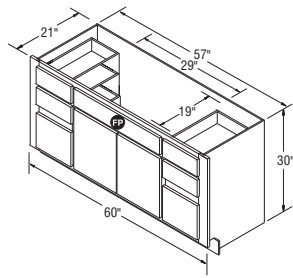

**VDDBT60** FX \*

\*Not available in full overlay door styles.

**NOTES** ✓

- ▶ 16" wide and 14" deep space for sink opening.
- ▶ One full height door.
- ▶ It may be necessary to modify the corner braces/stretcher rails with some sink applications.

**Vanity Sink Base, 30" High, 18" Wide, 16" Deep**

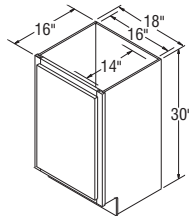

**VSB1816**

# Vanity Sink Bases, 30" High, 18" Deep

## NOTES ✓

- ▶ FP = False Panel.
- ▶ It may be necessary to modify the corner braces/stretcher rails with some sink applications.
- ▶ 18" deep Vanities available in Standard construction only.
- ▶ VSB2418 has butt doors on all door styles.

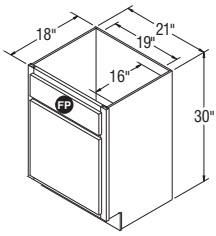

**VSB2118**

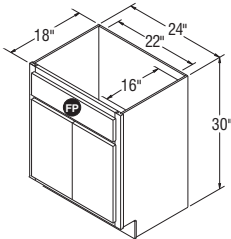

**VSB2418**

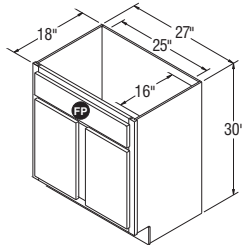

**VSB2718**

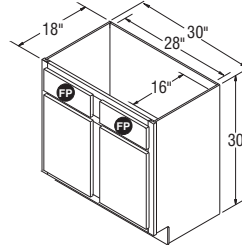

**VSB3018**

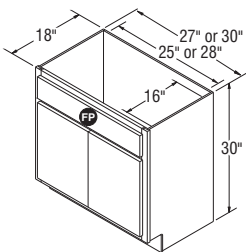

**VSB2718B  
VSB3018B**

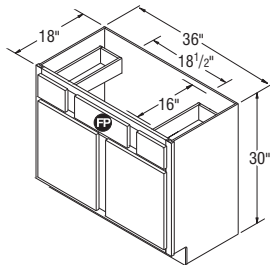

**VSB3618**

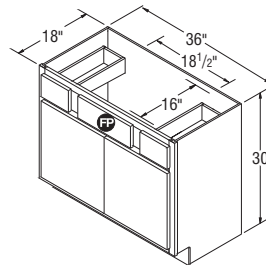

**VSB3618B**

**NOTES** ✓

- ▶ FP = False Panel.
- ▶ It may be necessary to modify the corner braces/stretcher rails with some sink applications.
- ▶ VSB24 has butt doors on all door styles.

## Vanity Sink Bases, 30" High, 21" Deep

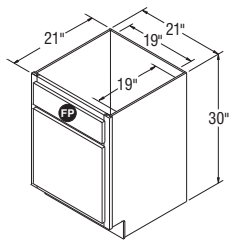

**VSB21**

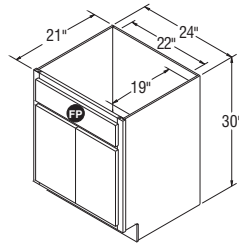

**VSB24**

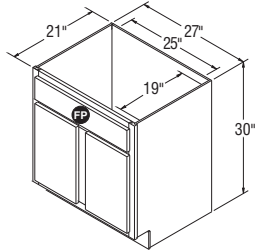

**VSB27**

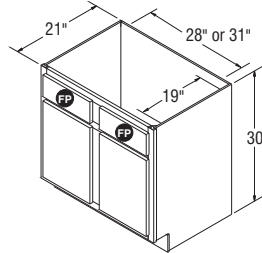

**VSB30**  
**VSB33**

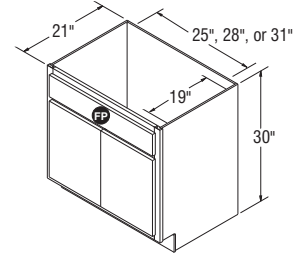

**VSB27B**  
**VSB30B**  
**VSB33B**

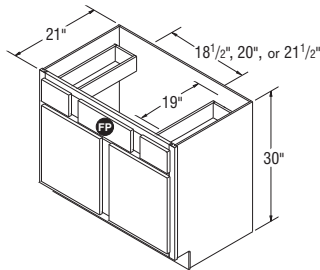

**VSB36** <sup>FX</sup>  
**VSB39** <sup>FX</sup>  
**VSB42** <sup>FX</sup>

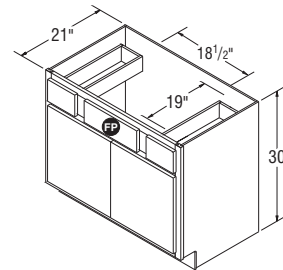

**VSB36B** <sup>FX</sup>

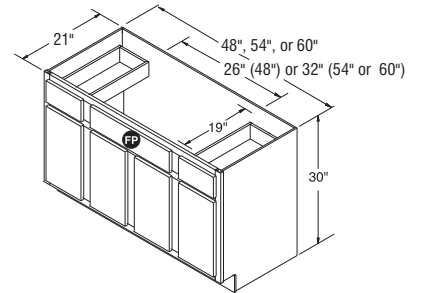

**VSB48** <sup>FX</sup>  
**VSB54** <sup>FX</sup>  
**VSB60** <sup>FX</sup>

# Vanity Sink Bases, 32 1/2" High, 21" Deep

## NOTES ✓

- ▶ FP = False Panel.
- ▶ Recommended for use in vanity designs for ADA compliance with a maximum installed height of 34".
- ▶ It may be necessary to modify the corner braces/stretcher rails with some sink applications.
- ▶ VSB2432.5 has butt doors on all door styles.

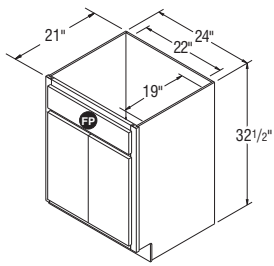

**VSB2432.5**

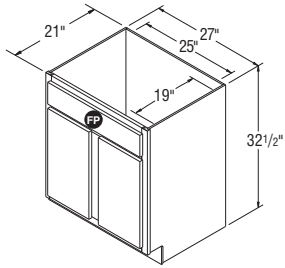

**VSB2732.5**

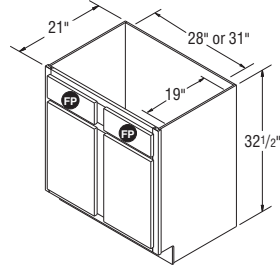

**VSB3032.5**  
**VSB3332.5**

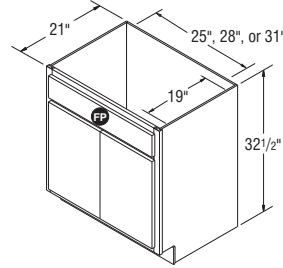

**VSB2732.5B**  
**VSB3032.5B**  
**VSB3332.5B**

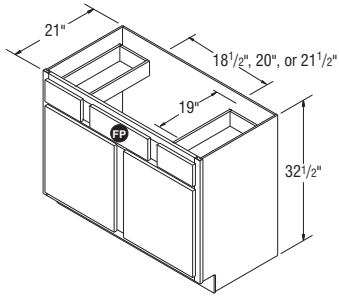

**VSB3632.5 FX**  
**VSB3932.5 FX**  
**VSB4232.5 FX**

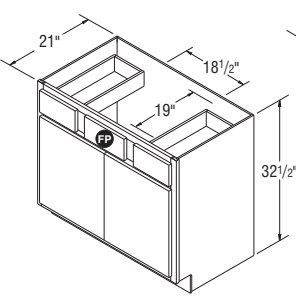

**VSB3632.5B FX**

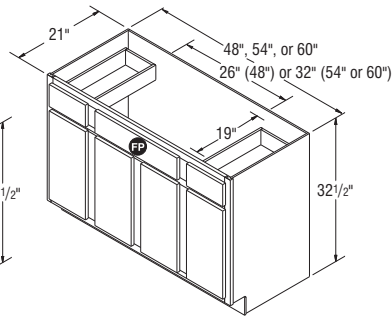

**VSB4832.5 FX**  
**VSB5432.5 FX**  
**VSB6032.5 FX**

NOTES ✓

- ▶ FP = False Panel.
- ▶ It may be necessary to modify the corner braces/stretcher rails with some sink applications.
- ▶ VSB2435 has butt doors on all door styles.

## Vanity Sink Bases, 35" High, 21" Deep

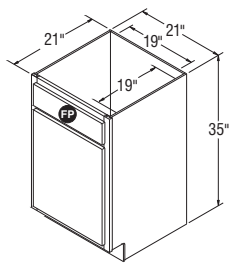

**VSB2135**

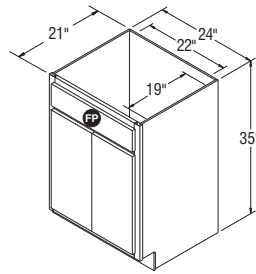

**VSB2435**

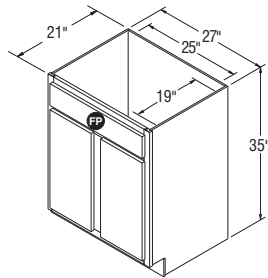

**VSB2735**

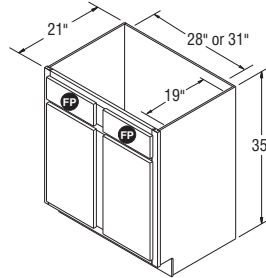

**VSB3035**  
**VSB3335**

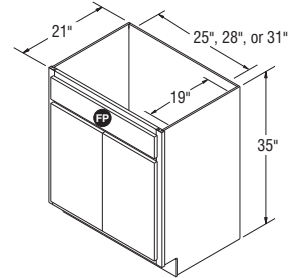

**VSB2735B**  
**VSB3035B**  
**VSB3335B**

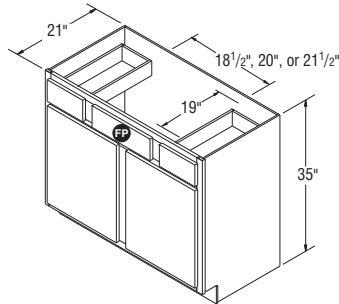

**VSB3635 FX**  
**VSB3935 FX**  
**VSB4235 FX**

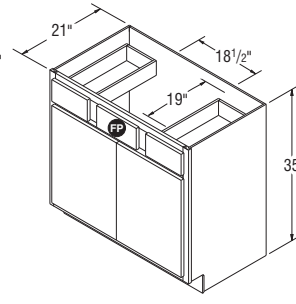

**VSB3635B FX**

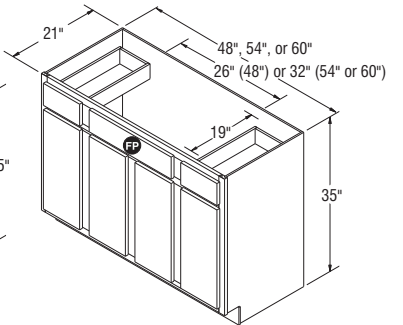

**VSB4835 FX**  
**VSB5435 FX**  
**VSB6035 FX**

## Vanity Sink Base SuperCabinets™ with Reversible Shelf, 35" High, 21" Deep

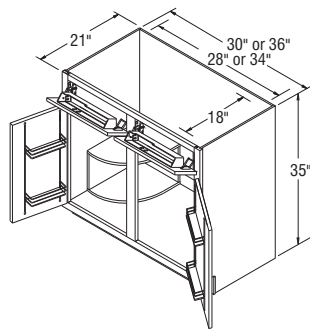

**VSB3035STS**  
**VSB3635STS**

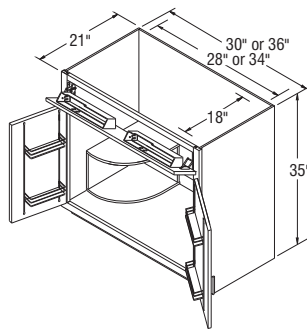

**VSB3035STSB**  
**VSB3635STSB**

### NOTES ✓

- ▶ Reversible Shelf will be constructed from 3/4" thick laminated furniture board. Shelf shipped secure, can be positioned in left or right corner.
- ▶ Both doors will have a chrome and wood two-tiered rack that is 3 3/8" deep.
- ▶ Includes two installed tip-out trays in false fronts.
- ▶ Quarter round shelf will be natural maple laminate for all styles, including White styles.



## Vanity Sink Base SuperCabinets™, 35" High, 21" Deep

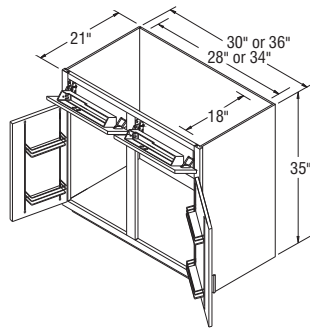

**VSB3035STNS**  
**VSB3635STNS**

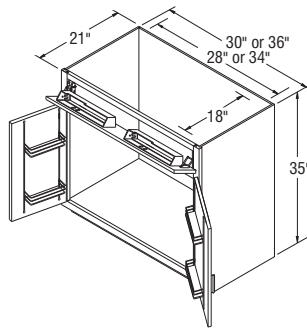

**VSB3035STNSB**  
**VSB3635STNSB**

### NOTES ✓

- ▶ Both doors will have a chrome and wood two-tiered rack that is 3 3/4" deep.
- ▶ Includes two installed tip-out trays.



## Vanity Sink Drawer Base, 30" High, 60" Wide, 21" Deep

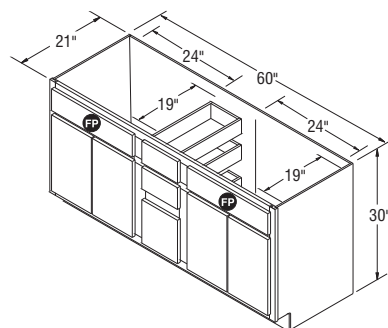

**VSDB60** FX

### NOTES ✓

- ▶ FP = False Panel.
- ▶ Four doors (two butt each end), three center drawers, two false drawer fronts, 24" wide (each side) and 19" deep space for sink opening (each side).
- ▶ It may be necessary to modify the corner braces/stretcher rails with some sink applications.

**NOTES** ✓

- ▶ FP = False Panel.
- ▶ Four doors (two butt each end), four center drawers, two false drawer fronts, 24" wide (each side) and 19" deep space for sink opening (each side).
- ▶ It may be necessary to modify the corner braces/stretchers rails with some sink applications.

**Vanity Sink Drawer Base, 35" High, 60" Wide, 21" Deep**

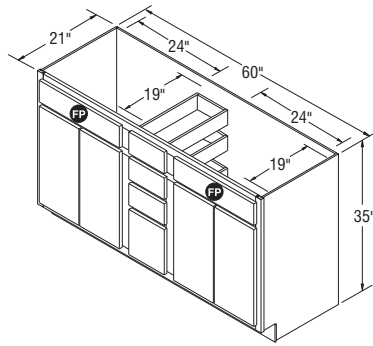

**VADB6035** FX

**NOTES** ✓

- ▶ FP = False Panel.
- ▶ Four doors (two butt each end), three center drawers, two false drawer fronts, 18" wide (each side) and 19" deep space for sink opening (each side).
- ▶ Cabinet is 57" wide.
- ▶ Front frame is 60" wide.
- ▶ Front end rails are each 3" and can be trimmed 1 1/2" each.

**Trimmable Vanity Sink Drawer Base, 30" High, 60" Wide, 21" Deep**

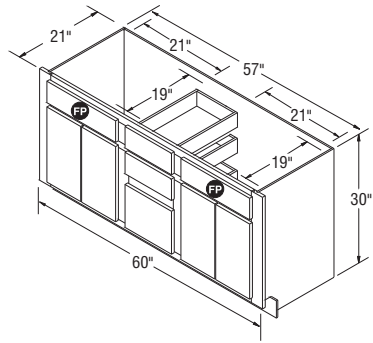

**VSDBT60** FX \*

\*Not available in full overlay door styles

**NOTES** ✓

- ▶ 18" deep Vanities available in Standard construction only.

**Vanity Four Drawer Bases, 30" High, 18" Deep**

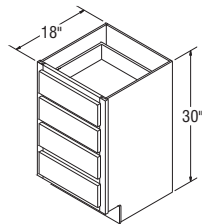

**VDB1218-4**  
**VDB1518-4**  
**VDB1818-4**

## Vanity Three Drawer Bases, 30" High, 18" Deep

### NOTES ✓

- ▶ The bottom drawer box is  $6\frac{3}{8}$ " high for Standard and 8" high for Select and APC.
- ▶ 18" deep Vanities available in Standard construction only.

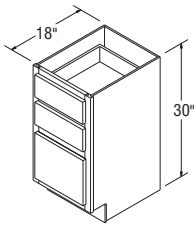

**VDB1218**  
**VDB1518**  
**VDB1818**

## Vanity Four Drawer Bases, 30" High, 21" Deep

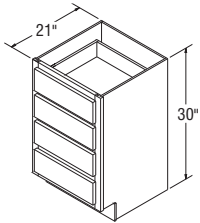

**VDB12-4** <sup>FX</sup>  
**VDB15-4** <sup>FX</sup>  
**VDB18-4** <sup>FX</sup>  
**VDB21-4** <sup>FX</sup>  
**VDB24-4** <sup>FX</sup>

## Vanity Three Drawer Bases, 30" High, 21" Deep

### NOTES ✓

- ▶ The bottom drawer box is  $6\frac{3}{8}$ " high for Standard and  $7\frac{3}{4}$ " high for Select and APC.

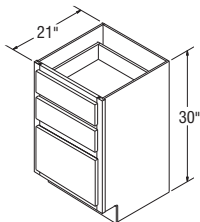

**VDB12** <sup>FX</sup>  
**VDB15** <sup>FX</sup>  
**VDB18** <sup>FX</sup>  
**VDB21** <sup>FX</sup>  
**VDB24** <sup>FX</sup>

## Vanity Four Drawer Bases, 35" High, 21" Deep

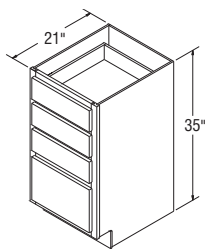

**VDB1235-4** FX  
**VDB1535-4** FX  
**VDB1835-4** FX  
**VDB2135-4** FX  
**VDB2435-4** FX

### NOTES ✓

- ▶ The bottom drawer box is  $6\frac{3}{8}$ " high for Standard and  $7\frac{3}{4}$ " high for Select and APC.

## Vanity Three Drawer Bases, 35" High, 21" Deep

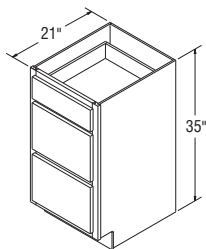

**VDB1235** FX  
**VDB1535** FX  
**VDB1835** FX  
**VDB2135** FX  
**VDB2435** FX

### NOTES ✓

- ▶ Two adjustable  $\frac{1}{2}$ " thick shelves.
- ▶ Must be surface mounted.
- ▶ Only available in Standard Construction.

## Vanity Wall Cabinet, 30" High, 12" Wide, 5" Deep

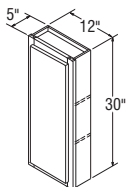

**VWC12\***

\*Specify L or R on all Arch styles.  
Doors will be Arch when ordering these styles.

## Vanity Wall Cabinet, 20" High, 15" Wide, 4 1/8" Deep

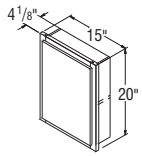

**VWC1520\***

\*Specify L or R on all Arch styles.  
Doors will be Arch when ordering these styles.

### NOTES ✓

- ▶ Must be recess mounted.
- ▶ Cut out dimensions:  
13<sup>5</sup>/<sub>8</sub>" W x 18<sup>5</sup>/<sub>8</sub>" H x 3<sup>3</sup>/<sub>8</sub>" D
- ▶ Only available in Standard Construction.
- ▶ Includes fixed shelf.

## Vanity Tank Topper, 31" High, 24" Wide, 9" Deep

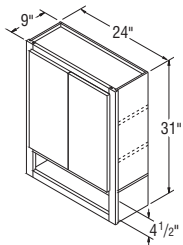

**VTT24**

### NOTES ✓

- ▶ Interior color is the same as exterior color.
- ▶ Two butt doors, open shelf.
- ▶ Two adjustable 3/4" thick shelves.
- ▶ Not available on Briarcliff II Arch, or Eastland Arch.
- ▶ Includes plastic U-shaped hinge spacers for better door alignment.

## Vanity Drawers Trimmable, 18" Deep (Trimmable 3")

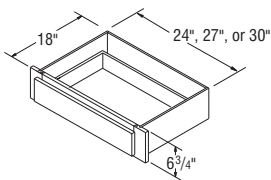

**VDT2718**  
**VDT3018**  
**VDT3318**

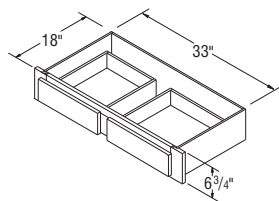

**VDT3618**

### NOTES ✓

- ▶ Cabinets may not feature matching exterior laminate, so installation between two adjacent cabinets, walls, and/or panels is recommended.
- ▶ 18" deep Vanities available in Standard construction only.
- ▶ Face frame trimmable 3" overall, 1 1/2" on each side.
- ▶ 18" deep Vanities available in Standard construction only.
- ▶ Not available in All Plywood Construction.

**NOTES** ✓

- ▶ Cabinets may not feature matching exterior laminate, so installation between two adjacent cabinets, walls, and/or panels is recommended.
- ▶ Face frame trimmable 3" overall, 1½" on each side.
- ▶ Not available in All Plywood Construction.

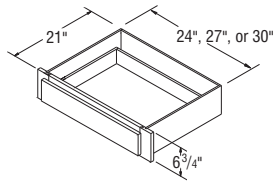
**Vanity Drawers Trimmable, 21" Deep (Trimmable 3")**

**VDT27** <sup>FX</sup>  
**VDT30** <sup>FX</sup>  
**VDT33** <sup>FX</sup>

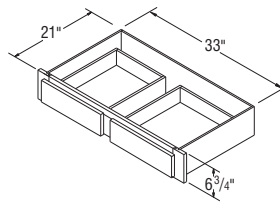

**VDT36** <sup>FX</sup>

**NOTES** ✓

- ▶ Two doors and one drawer.
- ▶ Top door will be an Arch in applicable styles.
- ▶ Upper doors cannot be cut for glass.
- ▶ Includes ¾" thick adjustable shelves, two in top section, one in bottom section and one fixed shelf.
- ▶ Drawer front height aligns with 35" Vanity/Base cabinet drawer fronts.
- ▶ Large openings on miter door styles will be two doors doweled together.
- ▶ 18" deep Vanities available in Standard construction only.

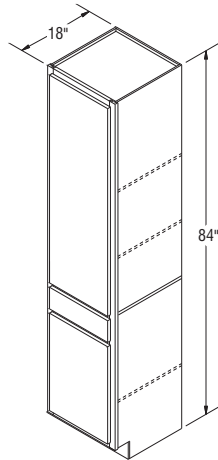
**Linen Closets with Drawer, 84" High, 18" Deep**

**LCD1818**\*  
**LCD2418**\*

\*Specify L or R on all styles.

## Linen Closets with Drawer, 84" High, 21" Deep

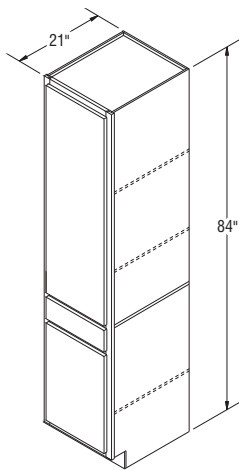

**LCD18\***  
**LCD24\***

\*Specify L or R on all styles.

### NOTES ✓

- ▶ Two doors and one drawer.
- ▶ Top door will be an Arch in applicable styles.
- ▶ Includes  $\frac{3}{4}$ " thick adjustable shelves, two in top section, one in bottom section and one fixed shelf.
- ▶ Drawer front height aligns with 35" Vanity/Base cabinet drawer fronts.
- ▶ Large openings on miter door styles will be two doors doweled together.



## Linen Closets SuperCabinet™ with Removable Hamper, 84" High, 21" Deep

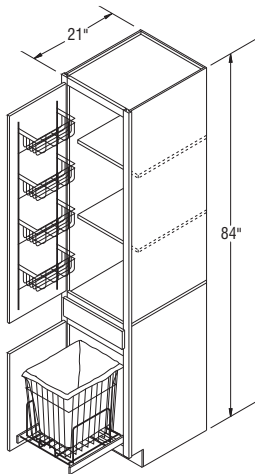

**LCD18SC FX \***

\*Specify L or R on all styles.

### NOTES ✓

- ▶ Two doors and one drawer.
- ▶ Top door will be an Arch in applicable styles.
- ▶ Includes two  $\frac{3}{4}$ " thick adjustable shelves and 5" deep chrome door rack.
- ▶ Drawer front height aligns with standard 35" Base cabinet drawer front.
- ▶ Large openings on miter door styles will be two doors doweled together.
- ▶ Includes Full Extension removable chrome pullout Hamper with removable cloth liner.



**NOTES** ✓

- ▶ Interior of cabinet is white for all styles.
- ▶ One mirrored door with solid wood frame.
- ▶ Can be surface or recess mounted.
- ▶ Box made of white formed plastic
- ▶ Includes two adjustable shelves and one adjustable toothbrush shelf (plastic).
- ▶ Cabinet is reversible.
- ▶ Cut out for recess: 14 1/4" W x 2 1/4" D x 21" H.



Vanity Medicine Cabinet, 24" High, 17" Wide, 4 3/8" Deep

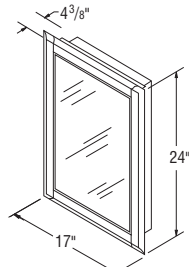

**VMC1724**

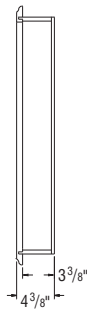

SIDE VIEW

**NOTES** ✓

- ▶ Three mirrored doors.
- ▶ Solid wood face frame.
- ▶ Can be surface or recess mounted.
- ▶ Chrome touch latches and hinges are used on doors.
- ▶ Box exterior matches face frame.
- ▶ Three fixed shelves.
- ▶ Cut out for recess:
  - VTMC2432 – 21 5/8" W x 3 15/16" D x 29 3/8" H.
  - VTMC3032 – 27 5/8" W x 3 15/16" D x 29 3/8" H.
  - VTMC3632 – 33 5/8" W x 3 15/16" D x 29 3/8" H.
  - VTMC4832 – 45 5/8" W x 3 15/16" D x 29 3/8" H.



Vanity Tri-View Medicine Cabinet, 32" High, 4" Deep

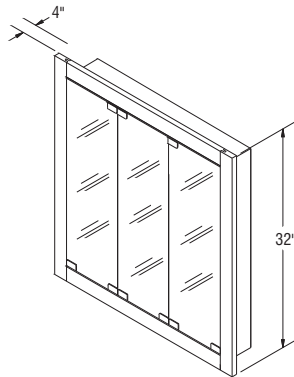

- VTMC2432**
- VTMC3032**
- VTMC3632**
- VTMC4832**

## Vanity Tapered End Panel, 30" High, 21" Deep

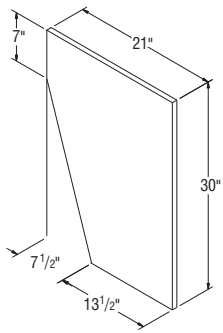

**VTEP**

### NOTES ✓

- ▶ 3/4" thick.
- ▶ Veneer panel with front edge banded.



## Lavatory Tip-Out Trays

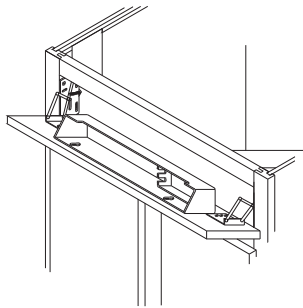

**LTOT11**  
**LTOT14**

### NOTES ✓

- ▶ White plastic storage accessory tray.
- ▶ Kit includes two hinges for installation.
- ▶ If LTOTs are used on full overlay style, it is recommended that a pull be used.
- ▶ See matrix on pages 128-129 to determine which cabinets LTOT will fit.
- ▶ Order under style #010.
- ▶ LTOT11 is 11" (White).
- ▶ LTOT14 is 14" (White).



## Linen Closet Shelf Kits

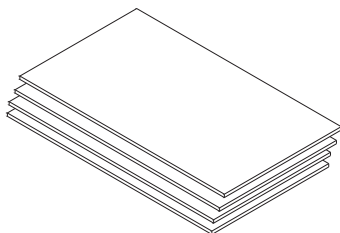

**LKS18C**  
**LKS18CWH**  
**LKS24C**  
**LKS24CWH**

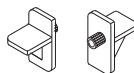

### NOTES ✓

- ▶ Four shelves with clips.
- ▶ Shelves can be trimmed in the field to accommodate 18" deep linen closets.
- ▶ Natural maple laminate or specify LKS\_ \_WH to match white interiors.
- ▶ Order under style #010.
- ▶ Dimensions:  
LKS18/LKS18WH – 1/2" T x 16 1/2" W x 20 3/16" D  
LKS24/LKS24WH – 1/2" T x 22 1/2" W x 20 3/16" D



**KEY**

- I** Can be installed without modification to cabinet.
- ✓ Recommended
- Not applicable

VANITY ACCESSORY MATRIX		
	LTOT11	LTOT14
<b>Cabinet</b>		
LCD1818	•	•
LCD2418	•	•
LCD18	•	•
LCD24	•	•
LCD185C	•	•
VB1218	•	•
VB1518	•	•
VB1818	•	•
VB2118	•	•
VB12	•	•
VB15	•	•
VB18	•	•
VB21	•	•
VB24	•	•
VB30	•	•
VB30B	•	•
VB1235	•	•
VB1535	•	•
VB1835	•	•
VB2135	•	•
VB2435	•	•
VB3035	•	•
VB3035B	•	•
VCB36	I	✓
VCB36B	I	✓
VCB42	I	I
VCB48	I	I
VCB3635	I	✓
VCB3635B	I	✓
VCB4235	I	I
VCB4835	I	I
VDD2418	I	I
VDD3018	I	•
VDD3618	I	✓
VDD24	I	✓
VDD30	I	•
VDD36	I	✓
VDD2435	I	✓
VDD3035	I	•
VDD3635	I	✓
Vddb4218	I	I
Vddb4818	I	I
Vddb42	I	I
Vddb48	I	I
Vddb60	I	I
Vddb4235	I	I
Vddb4835	I	I
Vddb6035	I	I
VddbT60	I	I
VSb2118	I	I
VSb2418	I	I
VSb2718	I	I

## VANITY ACCESSORY MATRIX

NOTES ✓

**KEY**

- I Can be installed without modification to cabinet.
- ✓ Recommended
- Not applicable

Cabinet	LTOT11	LTOT14
VSB2718B	I	I
VSB3018	✓	•
VSB3018B	✓	•
VSB3618	I	✓
VSB3618B	I	✓
VSB21	I	✓
VSB24	I	✓
VSB27	I	✓
VSB27B	I	✓
VSB30	I	•
VSB30B	I	✓
VSB33	I	•
VSB33B	I	✓
VSB36	I	•
VSB36B	I	•
VSB39	I	I
VSB42	I	I
VSB48	I	I
VSB54	I	I
VSB60	I	I
VSB2432.5	I	✓
VSB2732.5	I	✓
VSB2732.5B	I	✓
VSB3032.5	✓	•
VSB3032.5B	I	✓
VSB3332.5	✓	•
VSB3332.5B	I	•
VSB3632.5	I	•
VSB3632.5B	I	•
VSB2135	I	✓
VSB2435	I	I
VSB2735	I	I
VSB2735B	I	I
VSB3035	I	•
VSB3035B	I	✓
VSB3335	I	•
VSB3335B	I	✓
VSB3635	I	•
VSB3635B	I	✓
VSB3935	I	I
VSB4235	I	I
VSB4835	I	I
VSB5435	I	I
VSB6035	I	I
VSB3035STS	Included	•
VSB3035STSB	Included	•
VSB3635STS	•	Included
VSB3635STSB	•	Included
VSDB60	I	I
VSDB6035	I	I
VSDBT60	I	✓

**NOTES** ✓

- ▶ Includes one 3/4" full depth adjustable shelf.
- ▶ Not available in Arch door styles.

## Universal Design Notes

32 1/2" high cabinets are designed to comply with ADA (Americans with Disabilities Act) requirements of a 34" high overall counter height, including a 1 1/2" countertop.

Available in the following styles:

- ▶ Avalon Maple
- ▶ Benton Birch
- ▶ Landen Maple
- ▶ Landen Oak
- ▶ Oakland Oak
- ▶ Saybrooke Birch
- ▶ Sinclair Birch
- ▶ Westbury Oak

## Base Cabinets, 32 1/2" High

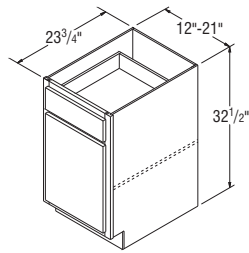

**B1232.5 FX**  
**B1532.5 FX**  
**B1832.5 FX**  
**B2132.5 FX**

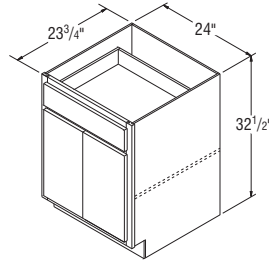

**B2432.5DD FX**

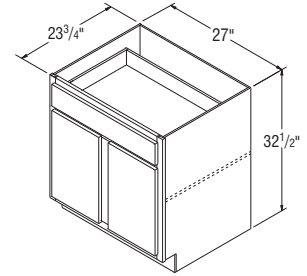

**B2732.5 FX**

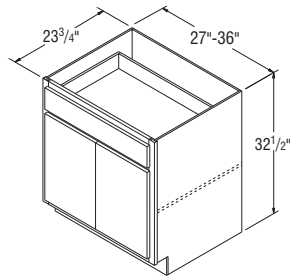

**B2732.5B FX**  
**B3032.5B FX**  
**B3332.5B FX**  
**B3632.5B FX**

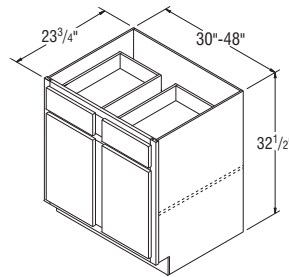

**B3032.5 FX**  
**B3332.5 FX**  
**B3632.5 FX**  
**B3932.5 FX**  
**B4232.5 FX**  
**B4832.5 FX**

**NOTES** ✓

- ▶ Includes one 3/4" full depth adjustable shelf.
- ▶ Not available in Arch door styles.

## Base Cabinets with Full Height Doors, 32 1/2" High

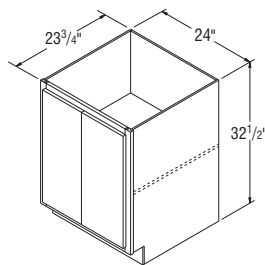

**B2432.5DDFH**

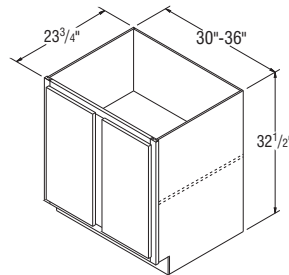

**B3032.5FH**  
**B3332.5FH**  
**B3632.5FH**

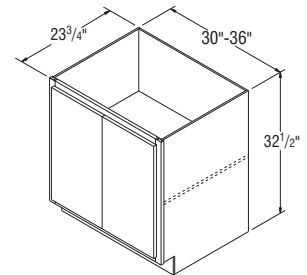

**B3032.5FHB**  
**B3332.5FHB**  
**B3632.5FHB**

## Sink Base Cabinets, 32 1/2" High

### NOTES ✓

- ▶ FP = False Panel.
- ▶ Not available in Arch door styles.
- ▶ It may be necessary to modify the corner braces with some sink applications.
- ▶ Shelves not included.

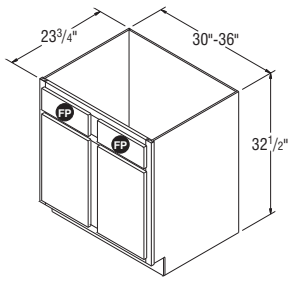

**SB3032.5**  
**SB3632.5**

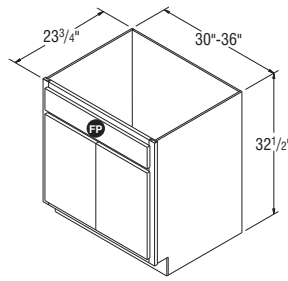

**SB3032.5B**  
**SB3632.5B**

## Sink Fronts, 32 1/2" High

### NOTES ✓

- ▶ FP = False Panel.
- ▶ Not available in Arch door styles.
- ▶ Sink Base Floor included with all units.
- ▶ Trimmable 3" each side.

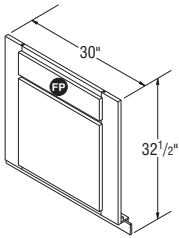

**SF3032.5**

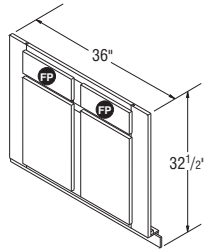

**SF3632.5**

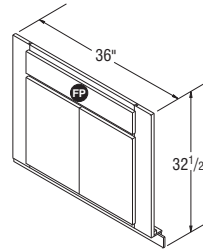

**SF3632.5B**

## Sink Unit Cabinets with Front Panel, 32 1/2" High

### NOTES ✓

- ▶ 26" and 32" wide and 16 1/2" deep space for sink opening.
- ▶ Not available in Arch door styles.
- ▶ Shipped unassembled.
- ▶ Removable front panel.
- ▶ Do not use or install as a freestanding unit.
- ▶ It may be necessary to modify the corner braces with some sink applications.
- ▶ Not available in All Plywood Construction.

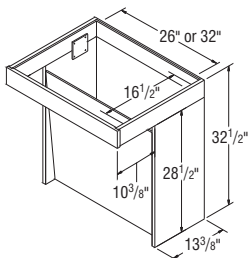

**SU3032.5**  
**SU3632.5**

**NOTES** ✓

- ▶ Removable plastic cutlery tray included in top drawer except for DB1232.5.
- ▶ Not available in Arch door styles.

### Three Drawer Base Cabinets, 32 1/2" High

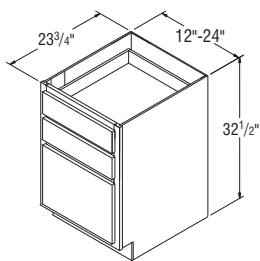

- DB1232.5** FX
- DB1532.5** FX
- DB1832.5** FX
- DB2132.5** FX
- DB2432.5** FX

**NOTES** ✓

- ▶ Two rotating 27" diameter white shelves with a 60 lb. load capacity per shelf.
- ▶ Not available in Arch door styles.
- ▶ One rotating door.
- ▶ Nominal gap of 1/4" on all sides of door.
- ▶ APC charges do not apply to SCR cabinets.

### Square Corner Roto Base Cabinet, 32 1/2" High

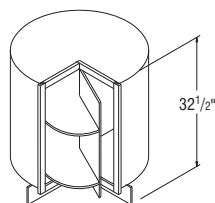

**SCR3632.5**

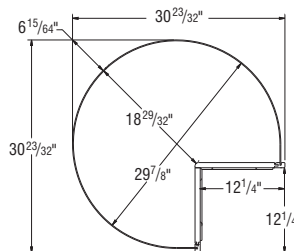

TOP VIEW

**NOTES** ✓

- ▶ One piano-hinged door.
- ▶ Not available in Arch door styles.
- ▶ Includes magnetic catch.
- ▶ Two 27" diameter rotating plastic white shelves that hold 60 lbs. per shelf.
- ▶ APC charges do not apply to BLS cabinets.

### Base Lazy Susan Cabinet, 32 1/2" High

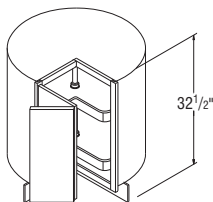

**BLS3632.5**

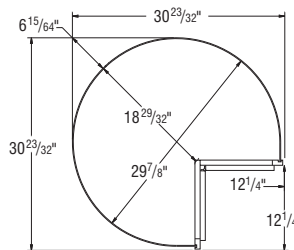

TOP VIEW

## Square Corner Base Cabinets, 32 1/2" High

### NOTES ✓

- ▶ All Square Corner Base cabinets are reversible.
- ▶ Not available in Arch door styles.
- ▶ 3" Filler is included with all Square Corner Base units.
- ▶ For minimum and maximum pull dimensions, see chart on pages 91 and 94.
- ▶ Includes one 3/4" thick adjustable shelf.

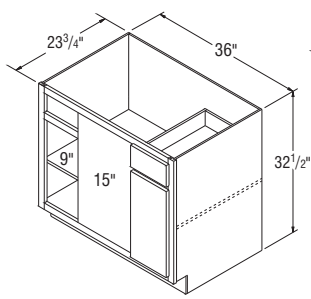

**SCB3632.5 FX**

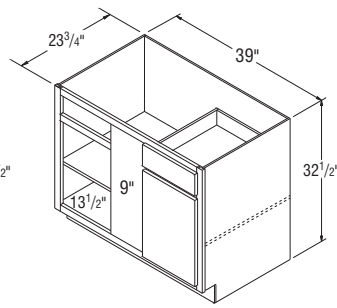

**SCB3932.5 FX**

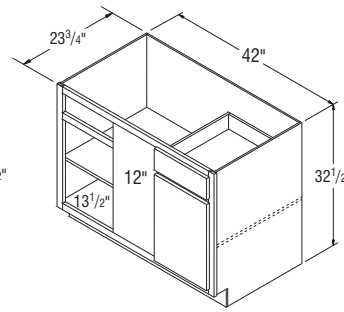

**SCB4232.5 FX**

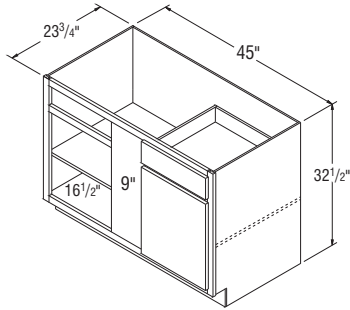

**SCB4532.5 FX**

## Base Built-In Microwave Cabinet, 32 1/2" High

### NOTES ✓

- ▶ Microwave opening is trimmable.
- ▶ Not available in Arch door styles.
- ▶ Designed for Built-in Microwaves with trim kits (Cabinet has standard Aristex® natural maple interior).

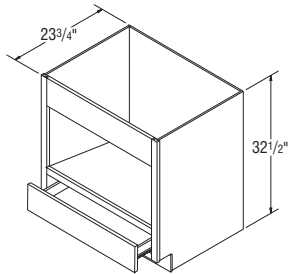

**BMW3032.5 FX**

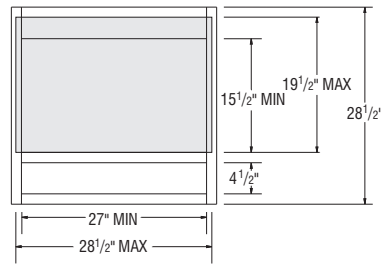

TRIM AREA

NOTES ✓

- ▶ Recommended installation height of 32½" to allow sufficient toe clearance for Universal Design stand-alone vanity applications as a wall hanging unit.
- ▶ Sink Opening Dimensions:  
Depth: 16¾"  
Widths: VWS2923 = 24⅜"  
VWS3223 = 27⅜"  
VWS3523 = 30⅜"  
VWS4123 = 36⅜"

Vanity Wall Sink Cabinets, 23" High *New*

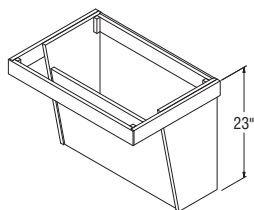

- VWS2923**
- VWS3223**
- VWS3523**
- VWS4123**

NOTES ✓

- ▶ Not available in Core door styles.
- ▶ Must be ordered with Vanity Wall Sink Cabinet (VWS). Not designed to be a stand-alone unit.
- ▶ Two plywood mending plates included to mount RVWS to VWS.
- ▶ Able to be removed for handicap accessible use.

Removable Vanity Wall Sink Cabinets, 32 ½" High, 21" Deep *New*

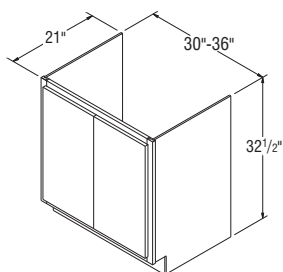

- RVWS3032B**
- RVWS3332B**
- RVWS3632B**

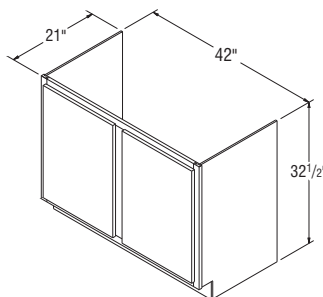

- RVWS4232**

## Scribe Moulding

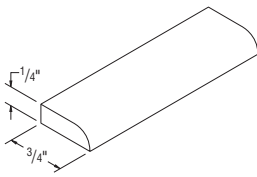

**MSW8**  
**MSW16**  
**MSW24**  
**MSW32**  
**MSW40**  
**MSW48**  
**MSW200**

## Outside Corner Moulding – 90° and 135°

### DESIGN SOLUTIONS

- Use to create a finished look on ends of cabinet runs.

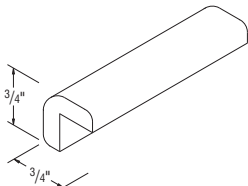

**MOCW8**  
**MOCW16**  
**MOCW24**  
**MOCW32**  
**MOCW40**  
**MOCW48**  
**MOCW200**

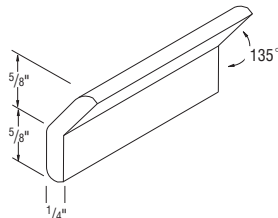

**MOC135-8**

## Triple Bead Moulding

### DESIGN SOLUTIONS

- Can be used with Inset Crown Moulding.

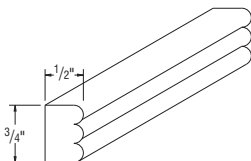

**MTBEAD8**  
**MTBEAD16**  
**MTBEAD24**

NOTES ✓

▶ MSHKRCROWN available in maple finishes only.

DESIGN SOLUTIONS

- ▶ For Moulding Solutions, see pages 36 & 37.
- ▶ Remember to order extra Mouldings when working with mitered corners.
- ▶ MICROWN is designed for inserts (i.e. dentil, rope, triple bead.)
- ▶ At minimum, leave a 3" reveal at the end of a run to allow Moulding and countertop ample clearance to return back to the wall.



Crown Moulding

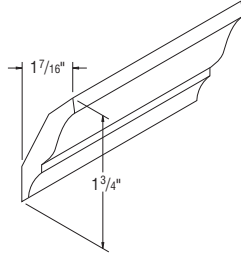

**MCROWN8 (1 - 8' pc)**  
**MCROWN16 (2 - 8' pc)**  
**MCROWN24 (3 - 8' pc)**

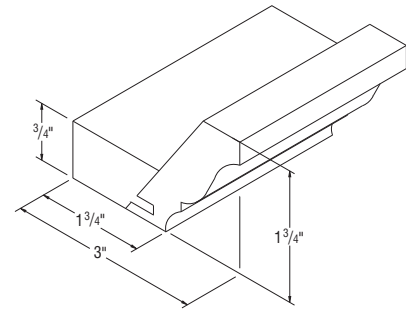

Full Overlay  
**MFOLCR8 (1 - 8' pc)**  
**MFOLCR16 (2 - 8' pc)**  
**MFOLCR24 (3 - 8' pc)**

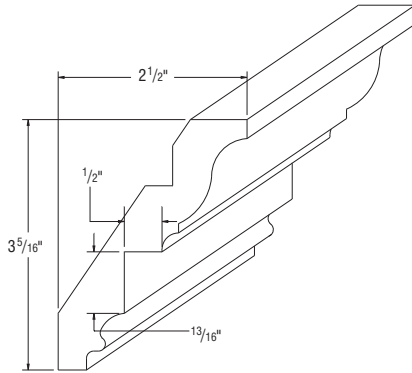

Insert  
**MICROWN8 (1 - 8' pc)**  
**MICROWN16 (2 - 8' pc)**  
**MICROWN24 (3 - 8' pc)**

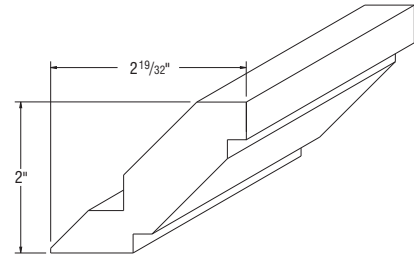

Shaker  
**MSHKRCROWN8 (1 - 8' pc)**  
**MSHKRCROWN16 (2 - 8' pc)**  
**MSHKRCROWN24 (3 - 8' pc)**

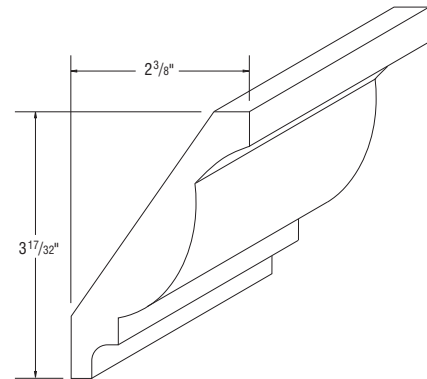

Tall  
**MTCROWN8 (1 - 8' pc)**

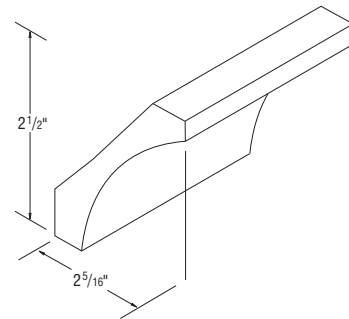

Small Cove  
**MSMCOVECR8 (1 - 8' pc)**

## Starter Moulding

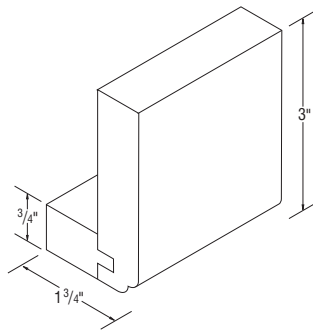

**MSTR8 (1 - 8' pc)**

### NOTES ✓

- ▶ Top-mount installation only (cleat is attached).

### DESIGN SOLUTIONS

- ▶ MSTR is for use with stacked moulding designs for ease of installation of top mouldings.



## Soffit Filler Mouldings

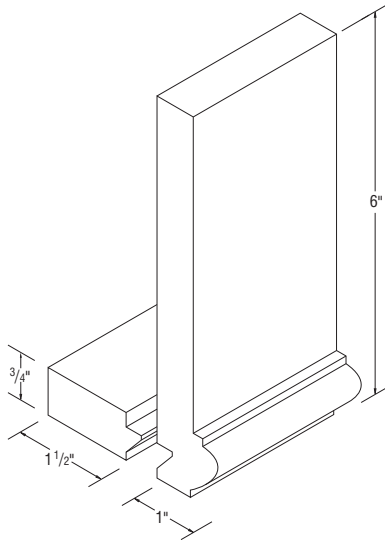

**MSFM8 (1 - 8' pc)**

### NOTES ✓

- ▶ Cleat shipped unattached, can be MSFM8 (1 - 8' pc) top or face mounted.

### DESIGN SOLUTIONS

- ▶ MSFM is for use with stacked moulding designs for ease of installation.



## Counter Top Moulding

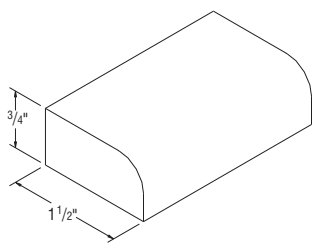

**MCTR8 (1 - 8' pc)**  
**MCTR16 (2 - 8' pc)**  
**MCTR24 (3 - 8' pc)**

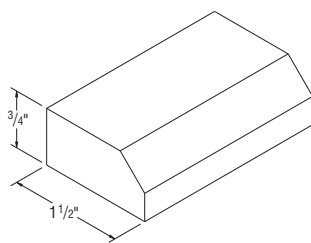

**MCTB8 (1 - 8' pc)**  
**MCTB16 (2 - 8' pc)**  
**MCTB24 (3 - 8' pc)**

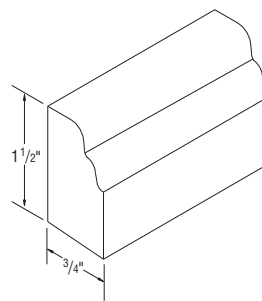

**MCTOG8 (1 - 8' pc)**  
**MCTOG16 (2 - 8' pc)**  
**MCTOG24 (3 - 8' pc)**

### DESIGN SOLUTIONS

- ▶ MCTB can be flipped upside-down and used as top trim.





### Cove Moulding

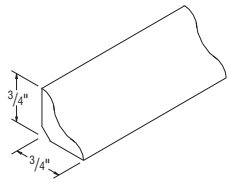

- MCV8** (1 - 8' pc)    **MCV40** (5 - 8' pc)
- MCV16** (2 - 8' pc)    **MCV48** (6 - 8' pc)
- MCV24** (3 - 8' pc)    **MCV200** (25 - 8' pc)
- MCV32** (4 - 8' pc)



### Quarter Round Moulding

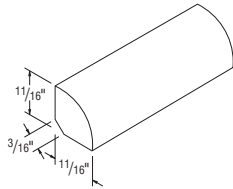

- MQR8** (1 - 8' pc)    **MQR40** (5 - 8' pc)
- MQR16** (2 - 8' pc)    **MQR48** (6 - 8' pc)
- MQR24** (3 - 8' pc)    **MQR200** (25 - 8' pc)
- MQR32** (4 - 8' pc)



### Batten Moulding

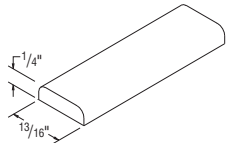

- MBAT8** (1 - 8' pc)    **MBAT32** (4 - 8' pc)
- MBAT16** (2 - 8' pc)    **MBAT40** (5 - 8' pc)
- MBAT24** (3 - 8' pc)    **MBAT48** (6 - 8' pc)



### Traditional Soffit Trim Moulding

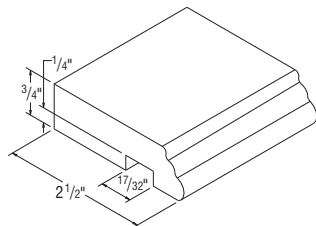

- MTST8** (1 - 8' pc)
- MTST16** (2 - 8' pc)
- MTST24** (3 - 8' pc)

## Traditional Cap Moulding

### DESIGN SOLUTIONS

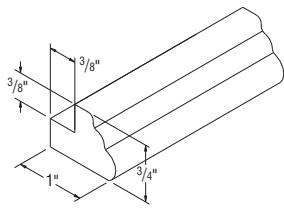

**MTCAP8 (1 - 8' pc)**  
**MTCAP16 (2 - 8' pc)**  
**MTCAP24 (3 - 8' pc)**

- ▶ MTCAP can be flipped upside-down and used as a base piece for a stacked top trim.



## Tall Light Rail Moulding

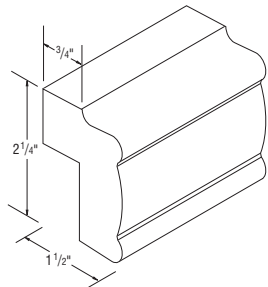

**MTLR8 (1 - 8' pc)**  
**MTLR16 (2 - 8' pc)**  
**MTLR24 (3 - 8' pc)**



## Light Rail Moulding

### NOTES ✓

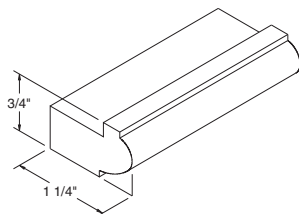

**MLR8 (1 - 8' pc)**  
**MLR16 (2 - 8' pc)**  
**MLR24 (3 - 8' pc)**

- ▶ Designed to mount under the face frame of Wall Cabinets.



## Traditional Trim Moulding

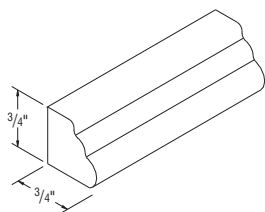

**MTT8 (1 - 8' pc)**  
**MTT16 (2 - 8' pc)**  
**MTT24 (3 - 8' pc)**



**DESIGN SOLUTIONS**

▶ MTBAT can be used with Insert Crown Moulding.



**Traditional Batten Moulding**

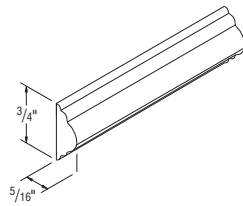

**MTBAT8 (1 - 8' pc)**  
**MTBAT16 (2 - 8' pc)**  
**MTBAT24 (3 - 8' pc)**

**NOTES** ✓

▶ MDENTIL can be used with Insert Crown Moulding.



**Dentil Moulding**

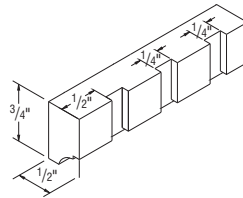

**MDENTIL8 (1 - 8' pc)**  
**MDENTIL16 (2 - 8' pc)**  
**MDENTIL24 (3 - 8' pc)**

**DESIGN SOLUTIONS**

▶ MROPE can be used with Insert Crown Moulding.



**Rope Moulding**

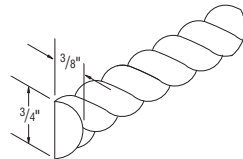

**MROPE8 (1 - 8' pc)**  
**MROPE16 (2 - 8' pc)**  
**MROPE24 (3 - 8' pc)**



**Base Shoe Moulding**

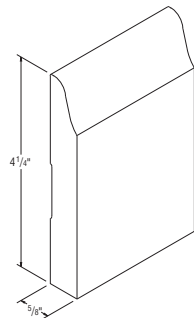

**MBS8 (1 - 8' pc)**  
**MBS16 (2 - 8' pc)**  
**MBS24 (3 - 8' pc)**

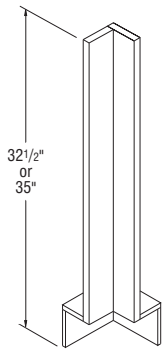

**FBC3X332.5**  
**FBC3X3**

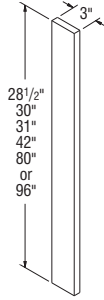

**F328.5**  
**F330**  
**F331**  
**F342**  
**F380**  
**F396 *New***

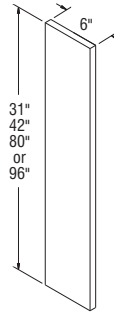

**F631**  
**F642**  
**F680**  
**F696 *New***

- ▶ FBC3X3 Overlays available for Briarcliff II, Durham, Eastland, Ellsworth, Nantucket, Overton, and Wentworth. Must order separately under OL3X3 code.
- ▶ All Fillers finished on front and two long edges, except for F531A45 and BLVDFF331 which are finished on both sides and both long edges.
- ▶ All Fillers are 3/4" thick.
- ▶ BLVDFF331 - 45° reversible angled Filler (fluted one side). Comes as a pair. Reversible, finished on back.
- ▶ F531A45 - 45° reversible decorative angled Filler (fluted one side). Comes as a pair. Trimmable 2" top and bottom. Reversible, finished on back.
- ▶ TKF3 - Toekick Filler. Order under style #010.

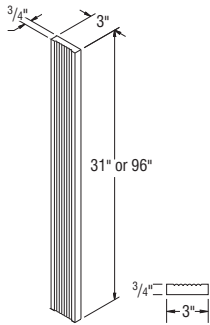

3" Reeded Fillers

**FF331**  
**FF396**

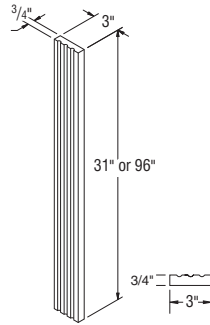

3" Fluted Fillers

**FFL331**  
**FFL396**

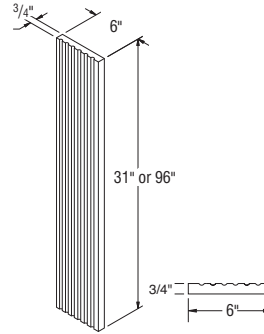

6" Fluted Fillers

**FFL631**  
**FFL696**

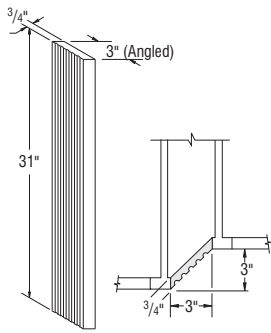

Angled Fluted/  
Plain Filler

**BLVDFF331**

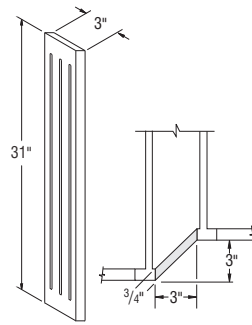

Decorative Angled Fluted/  
Plain Filler

**F531A45**



**TKF3\***

\*Order under style #010.



## Overlays\*

\* Overlays are only available in Briarcliff II, Durham, Eastland, Ellsworth, Nantucket, Overton and Wentworth.

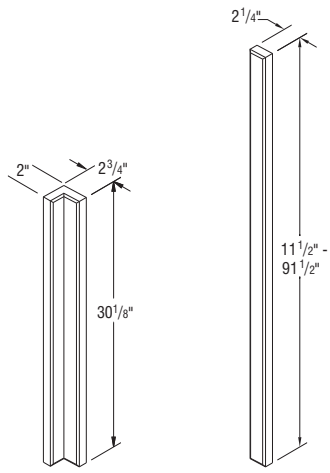

**OL3X3**

**OL12**

**OL335**

**OL14**

**OL36**

**OL18**

**OL42**

**OL24**

**OL80**

**OL26**

**OL86**

**OL30**

**OL92**

**OL31**

Model	Dimensions	Usage Details
OL3X3	2" x 30 <sup>1</sup> / <sub>8</sub> " & 2 <sup>3</sup> / <sub>4</sub> " x 30 <sup>1</sup> / <sub>8</sub> "	FBC3X3 Base Corner Filler
OL12	2 <sup>1</sup> / <sub>4</sub> " x 11 <sup>1</sup> / <sub>2</sub> "	12" high Wall
OL14	2 <sup>1</sup> / <sub>4</sub> " x 13 <sup>1</sup> / <sub>2</sub> "	14" high Wall
OL18	2 <sup>1</sup> / <sub>4</sub> " x 17 <sup>1</sup> / <sub>2</sub> "	18" high Wall
OL24	2 <sup>1</sup> / <sub>4</sub> " x 23 <sup>1</sup> / <sub>2</sub> "	24" high Wall
OL26	2 <sup>1</sup> / <sub>4</sub> " x 25 <sup>1</sup> / <sub>2</sub> "	30" high Vanity
OL30	2 <sup>1</sup> / <sub>4</sub> " x 29 <sup>1</sup> / <sub>2</sub> "	30" high Wall
OL31	2 <sup>1</sup> / <sub>4</sub> " x 30 <sup>1</sup> / <sub>8</sub> "	35" high Base/Vanity
OL335	2 <sup>1</sup> / <sub>4</sub> " x 30 <sup>1</sup> / <sub>8</sub> "	PEPR335 Panels
OL36	2 <sup>1</sup> / <sub>4</sub> " x 35 <sup>1</sup> / <sub>2</sub> "	36" high Wall
OL42	2 <sup>1</sup> / <sub>4</sub> " x 41 <sup>1</sup> / <sub>2</sub> "	42" high Wall
OL80	2 <sup>1</sup> / <sub>4</sub> " x 79 <sup>1</sup> / <sub>2</sub> "	84" high Utility
OL86	2 <sup>1</sup> / <sub>4</sub> " x 85 <sup>1</sup> / <sub>2</sub> "	90" high Utility
OL92	2 <sup>1</sup> / <sub>4</sub> " x 91 <sup>1</sup> / <sub>2</sub> "	96" high Utility

## Overlays\* *New*

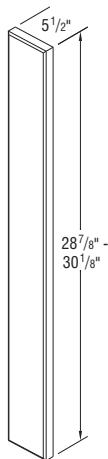

**OL631**

Model	Dimensions	Usage Details
OL631	Full Overlay Door Styles 5 <sup>1</sup> / <sub>2</sub> " x 28 <sup>7</sup> / <sub>8</sub> "	35" high Base/Vanity
	Partial Overlay Door Styles 5 <sup>1</sup> / <sub>2</sub> " x 30 <sup>1</sup> / <sub>8</sub> "	35" high Base/Vanity

## Split Turnings

NOTES ✓

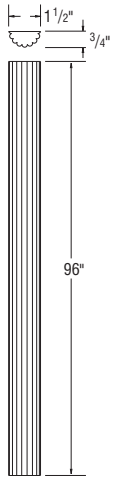

**REED96**  
(each)

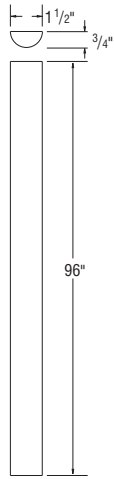

**SPOOL96**  
(each)

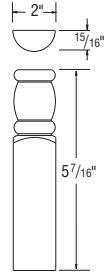

**SPRINGEND**  
(pair)

- ▶ SPRINGEND is sold in pairs and are trimmable up to 5" each.



## Rosette

NOTES ✓

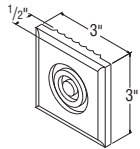

**FFROS3X3**

- ▶ Grooved to fit FFs.



## Mission Rosette

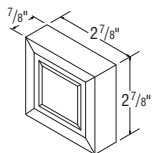

**ROSETTEMIS**

**NOTES** ✓

- ▶ Can be added to all Wood Hoods, except Canopy Wood Hood Arch (WHCA), for decorative embellishment. (See page 63).



**Acanthus Overlay**

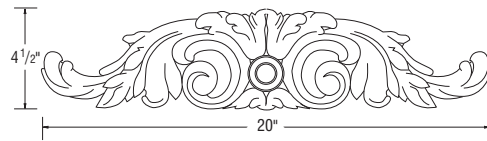

**ACOVLY**

**NOTES** ✓

- ▶ Finished on all sides (reversible).
- ▶ Not intended to be used as a freestanding shelf support.
- ▶ VCORBEL sold in pairs.
- ▶ VCORBEL is 3/4" thick.
- ▶ VCORBEL11 has a 3" wide back plate.



**Valance Corbels, 4" & 9 1/4" High**

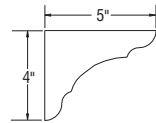

**VCORBEL**  
(pair)

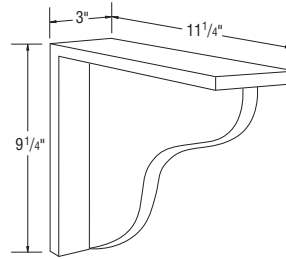

**VCORBEL11**

**NOTES** ✓

- ▶ In order to support substantial weight, Corbels must be properly installed with the attachment screws driven into a stud wall.



**Art Corbel, 9" High**

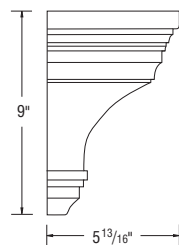

**CORBELART9**

## Mission Corbels, 6" & 9" High

### NOTES ✓

- In order to support substantial weight, Corbels must be properly installed with the attachment screws driven into a stud wall.

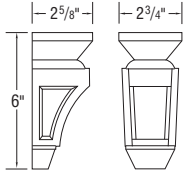

**CORBELMIS6**

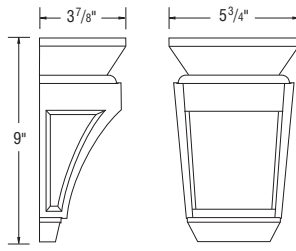

**CORBELMIS9**

## Corbels, 9" & 13" High

### DESIGN SOLUTIONS

- In order to support substantial weight, Corbels must be properly installed with the attachment screws driven into a stud wall.

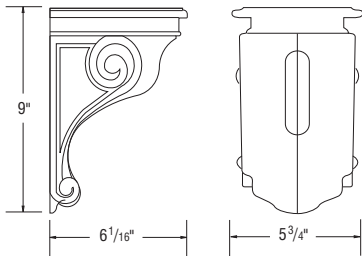

**SMCORBEL**

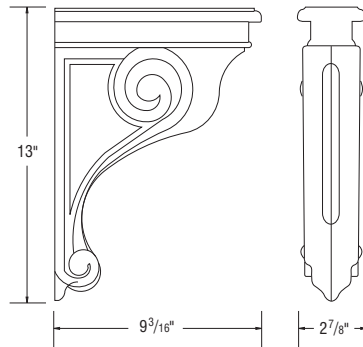

**LGCORBEL**



## Decorative Legs and Feet

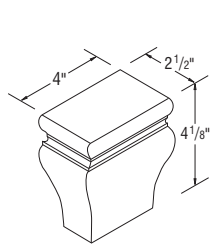

**TKTLFOOT**

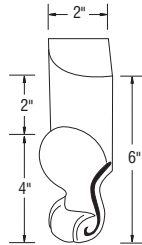

**FRNLEG**

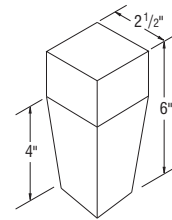

**TAPLEG**

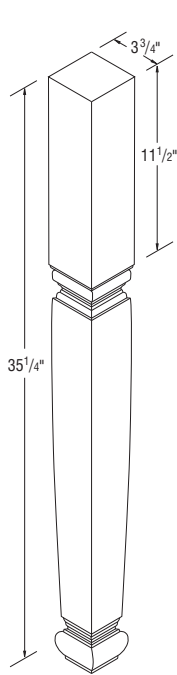

**ISLEGSQ**

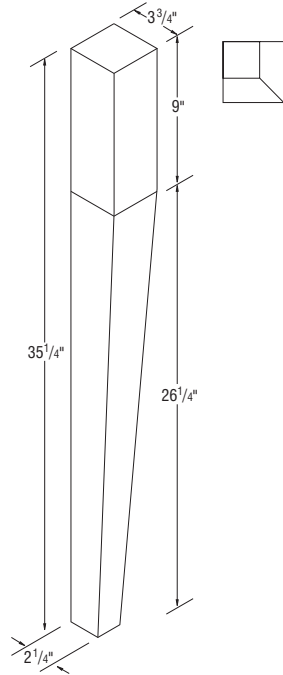

**ISLEG2S**

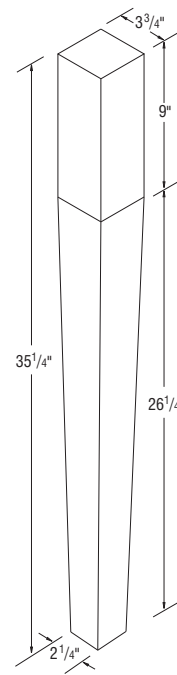

**ISLEG4S**

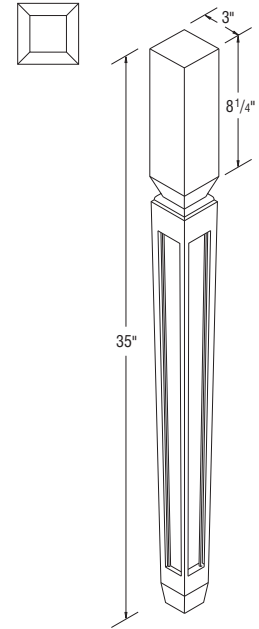

**DLEGMISION**

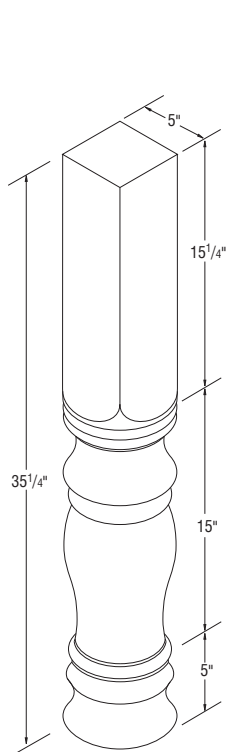

**ENGISLCOLUMN**

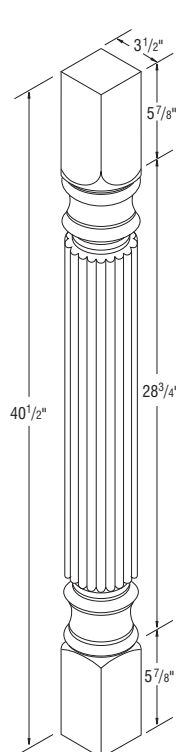

**RDLEG**

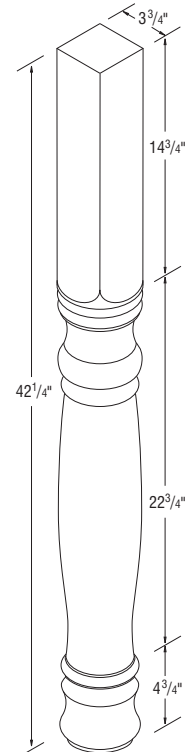

**ENGBARCOLUMN**

## Valances Scalloped, 4 9/16" High



V549SC  
V561SC  
V573SC

Model	Length
V549SC	49"
V561SC	61"
V573SC	73"

### DESIGN SOLUTIONS

- ▶ 3/4" thick.
- ▶ Trimmable up to 1/2" on each side: 1" overall.
- ▶ Valances not finished on back or ends.



## Valances Arch, 5" High



V525RA  
V531RA  
V537RA  
V543RA  
V549RA  
V561RA  
V573RA

Model	A =	Length
V525RA	4 1/4"	25"
V531RA	4 1/4"	31"
V537RA	4 1/4"	37"
V543RA	4 1/2"	43"
V549RA	4 1/2"	49"
V561RA	6"	61"
V573RA	6 3/4"	73"

### NOTES ✓

- ▶ 3/4" thick.
- ▶ Valances not finished on back or ends.



## Valances Straight, 5" High or 8 7/8" High



V531ST  
V537ST  
V540ST  
V543ST  
V546ST  
V549ST  
V561ST  
V573ST



V937ST  
V949ST  
V961ST  
V973ST

Model	Length
V531ST	31"
V537ST	37"
V540ST	40"
V543ST	43"
V546ST	46"
V549ST	49"
V561ST	61"
V573ST	73"
V937ST	37"
V949ST	49"
V961ST	61"
V973ST	73"

### DESIGN SOLUTIONS

- ▶ 3/4" thick.
- ▶ Valances not finished on back or ends.



► PEPR overlays available in Briarcliff II, Durham, Eastland, Ellsworth, Nantucket, and Wentworth. Must order separately under OL335 product code. (See page 142.)

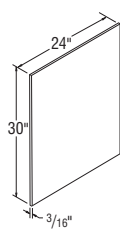

**PDWP**

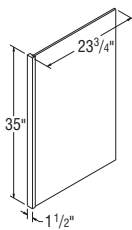

**PEPR1.535  
PEPR335 \*\***

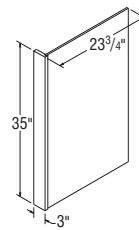

**PEPRPLY1.535\*  
PEPRPLY335**

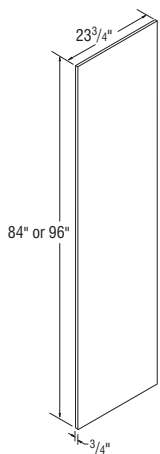

**PREF2384  
PREF2396**

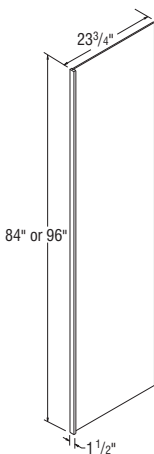

**PREPRP1.584 †  
PREPRP1.596 †**

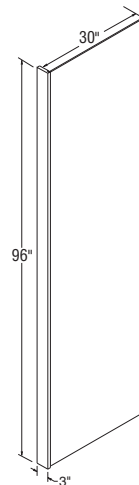

**PREPR33096**

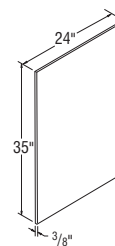

**PSFEP**

\*When PEPRPLY1.535 is ordered in Rustic Finishes, rustic characteristics on Panel only.

\*\*PEPR335 has rustic characteristics on Filler only.

†PREPRP1.584 and PREPRP1.596 will be laminate when ordered in White and Antique styles. When ordered in Rustic Finishes, rustic characteristics on Panels only.

Panel	Description	Size (T x W x H)	Edge Finish	Color Side 1	Color Side 2	Finish
PDWP	Dishwasher Front Panel	3/16" x 24" x 30"	None	Exterior	Raw	Veneer
PEPR1.535	Aristex™ 3/8" End Panel w/1 1/2" Stile	1 1/2" x 23 3/4" x 35"	Front Long	Exterior	Interior	Laminate
PEPR335 **	Aristex™ 3/8" End Panel w/3" Stile	3" x 23 3/4" x 35"	Front Long	Exterior	Interior	Laminate
PEPRPLY1.535 *	Plywood 3/8" End Panel w/1 1/2" Stile	1 1/2" x 23 3/4" x 35"	Front Long	Exterior	Interior	Veneer
PEPRPLY335	Plywood 3/8" End Panel/ Stile Complete	3" x 23 3/4" x 35"	Front Long	Exterior	Interior	Veneer
PREF2384	Particle Board Refrigerator End Panel	3/4" x 23 3/4" x 84"	1 Long	Exterior	Exterior	Veneer
PREF2396	Particle Board Refrigerator End Panel	3/4" x 23 3/4" x 96"	1 Long	Exterior	Exterior	Veneer
PREPRP1.584 †	Plywd. 3/8" Refrigerator End Panel w/1 1/2" Stile	1 1/2" x 23 3/4" x 84"	Front Long	Exterior	Exterior	Veneer
PREPRP1.596 †	Plywd. 3/8" Refrigerator End Panel w/1 1/2" Stile	1 1/2" x 23 3/4" x 96"	Front Long	Exterior	Exterior	Veneer
PREPR33096	Veneered Furniture Board Refrigerator 3/4" End Panel w/3" Stile	3" x 30" x 96"	Front Long	Exterior	Exterior	Veneer
PSFEP	Aristex™ Sink End Panel	3/8" x 24" x 35"	None	Exterior	Interior	Laminate

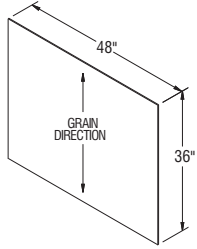

**PA4836**  
**P4836**

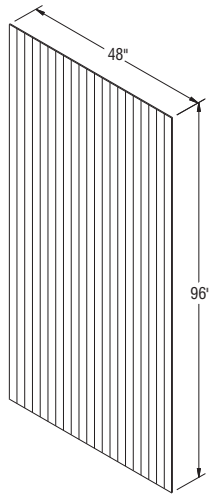

**BP4896**

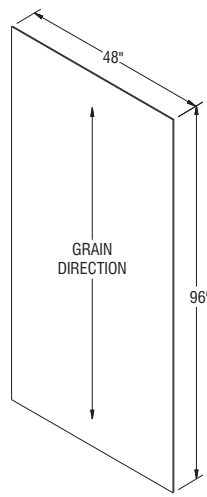

**PA4896**  
**P4896**

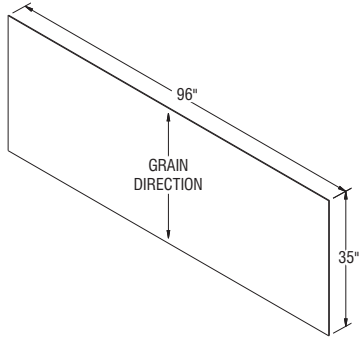

**PP9635\***

\*PP9635 is not available in White or Antique finishes.

Panel	Description	Size (T x W x H)	Edge Finish	Color Side 1	Color Side 2	Finish
BP4896	Beadboard Panel	3/16" x 48" x 96"	None	Exterior	Raw	Veneer
PA4836	Stock Panel - Aristex™ Laminate	1/4" x 48" x 36"	None	Exterior	Raw	Laminate
PA4896	Stock Panel - Aristex™ Laminate	1/4" x 48" x 96"	None	Exterior	Raw	Laminate
PP9635 *	Stock Panel - Veneer	3/16" x 96" x 35"	None	Exterior	Raw	Veneer
P4836	Stock Panel - Veneer	3/16" x 48" x 36"	None	Exterior	Raw	Veneer
P4896	Stock Panel - Veneer	3/16" x 48" x 96"	None	Exterior	Raw	Veneer

**NOTES** ✓

- ▶ End Panels are shipped one per carton. Not sold in pairs.
- ▶ EPV1430 and EPV1442 are sized for 15" deep cabinets.



## Veneer End Panels *New*

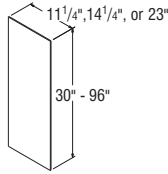

- EPV1130 EPV2335**
- EPV1142 EPV2384**
- EPV1430 EPV2396**
- EPV1442**

Panel	Description	Size (T x W x H)	Edge Finish	Color Side 1	Color Side 2	Finish
EPV1130	Wall End Panel for 12" Depth	3/16" x 11 1/4" x 30"	None	Exterior	Raw	Veneer
EPV1142	Wall End Panel for 12" Depth	3/16" x 11 1/4" x 42"	None	Exterior	Raw	Veneer
EPV1430	Wall End Panel for 15" Depth	3/16" x 14 1/4" x 30"	None	Exterior	Raw	Veneer
EPV1442	Wall End Panel for 15" Depth	3/16" x 14 1/4" x 42"	None	Exterior	Raw	Veneer
EPV2335	Base End Panel	3/16" x 23" x 35"	None	Exterior	Raw	Veneer
EPV2384	Utility End Panel	3/16" x 23" x 84"	None	Exterior	Raw	Veneer
EPV2396	Utility End Panel	3/16" x 23" x 96"	None	Exterior	Raw	Veneer

**DESIGN SOLUTIONS**

- ▶ 1/4" thick panels with one-sided Aristex™ laminate on exterior (no edge finish).
- ▶ End Panels are shipped one per carton. Not sold in pairs.
- ▶ EPA1430 and EPA1442 are sized for 15" deep cabinets.



## Laminate End Panels

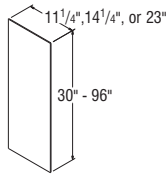

- EPA1130 EPA2335**
- EPA1142 EPA2384**
- EPA1430 EPA2396**
- EPA1442**

Panel	Description	Size (T x W x H)	Edge Finish	Color Side 1	Color Side 2	Finish
EPA1130	Wall End Panel for 12" Depth	1/4" x 11 1/4" x 30"	None	Exterior	Raw	Laminate
EPA1142	Wall End Panel for 12" Depth	1/4" x 11 1/4" x 42"	None	Exterior	Raw	Laminate
EPA1430	Wall End Panel for 15" Depth	1/4" x 14 1/4" x 30"	None	Exterior	Raw	Laminate
EPA1442	Wall End Panel for 15" Depth	1/4" x 14 1/4" x 42"	None	Exterior	Raw	Laminate
EPA2335	Base End Panel	1/4" x 23" x 35"	None	Exterior	Raw	Laminate
EPA2384	Utility End Panel	1/4" x 23" x 84"	None	Exterior	Raw	Laminate
EPA2396	Utility End Panel	1/4" x 23" x 96"	None	Exterior	Raw	Laminate

# Decorative End Panels

NOTES ✓

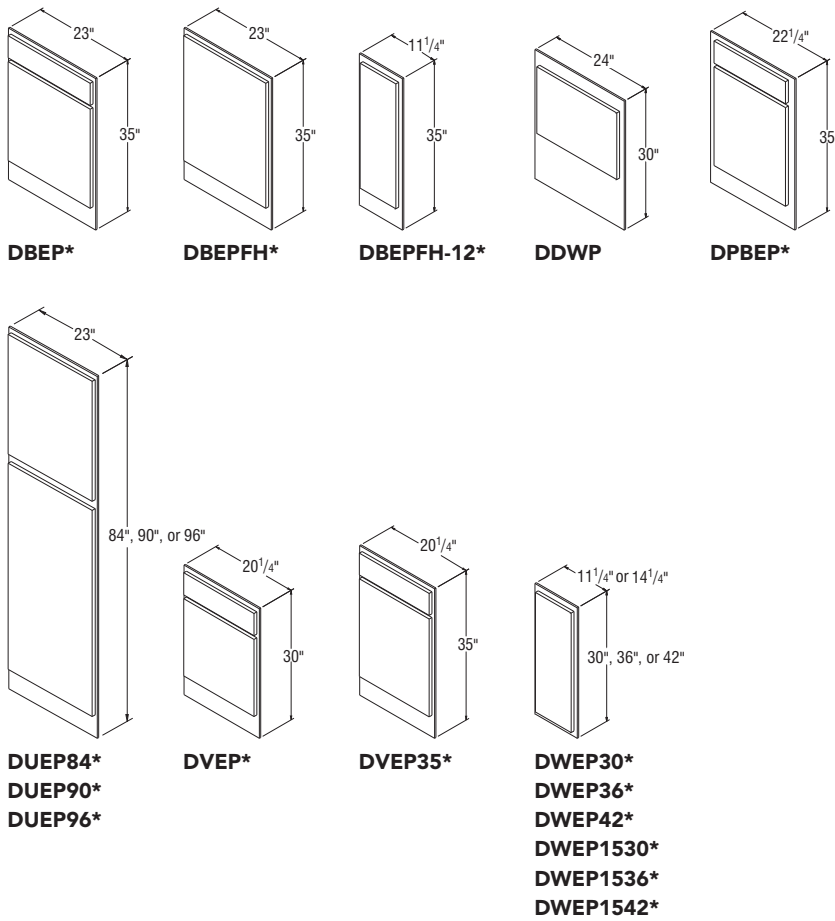

- ▶ DBEP and DPBEP include one door and one drawer front on an EP2335 Veneer End Panel and five screws for mounting.
- ▶ DBEPFH includes one door on an EP2335 Veneer End Panel and five screws for mounting.
- ▶ DBEPFH-12 includes one door on a Veneer Panel and five screws for mounting.
- ▶ DDWP includes one door, one Panel 24" x 30", and screws for installation. Shipped unassembled.
- ▶ DUEP includes two doors and one EP\_\_ Veneer End Panel, and screws for assembly. Shipped assembled.
- ▶ DUEP includes three doors on miter styles.
- ▶ DVEP includes one door, one drawer front, and one Panel 20 1/4" x 30", and screws for assembly. Shipped assembled.
- ▶ DWEP parts include one door and an EP\_\_ Veneer End Panel and four screws for mounting. Shipped assembled.
- ▶ Actual sizes of doors and drawer fronts used will vary slightly by style. For exact dimensions, refer to parts dimension guide.
- ▶ Panel construction is the same for Standard, Select, and APC.

\*Specify L or R on full overlay styles for all Decorative Panels except DDWP.

Panel	Description	Size (T x W x H)	Edge Finish	Color Side 1	Color Side 2	Finish
DBEP & DBEPFH *	Decorative Base End	3/16" x 23" x 35"	None	Exterior	Raw	Veneer
DBEPFH-12 *	Decorative Base End for 12" Depth	3/16" x 11 1/4" x 35"	None	Exterior	Raw	Veneer
DDWP	Decorative Dishwasher Front	3/16" x 24" x 30"	None	Exterior	Raw	Veneer
DPBEP *	Decorative Peninsula Base End	3/16" x 22 1/4" x 35"	None	Exterior	Raw	Veneer
DUEP84 *	Decorative Utility End	3/16" x 23" x 84"	None	Exterior	Raw	Veneer
DUEP90 *	Decorative Utility End	3/16" x 23" x 90"	None	Exterior	Raw	Veneer
DUEP96 *	Decorative Utility End	3/16" x 23" x 96"	None	Exterior	Raw	Veneer
DVEP *	Decorative Vanity End	3/16" x 20 1/4" x 30"	None	Exterior	Raw	Veneer
DVEP35 *	Decorative Vanity End	3/16" x 20 1/4" x 35"	None	Exterior	Raw	Veneer
DWEP30 *	Decorative Wall End	3/16" x 11 1/4" x 30"	None	Exterior	Raw	Veneer
DWEP36 *	Decorative Wall End	3/16" x 11 1/4" x 36"	None	Exterior	Raw	Veneer
DWEP42 *	Decorative Wall End	3/16" x 11 1/4" x 42"	None	Exterior	Raw	Veneer
DWEP1530 *	Decorative Wall End for 15" Depth	3/16" x 14 1/4" x 30"	None	Exterior	Raw	Veneer
DWEP1536 *	Decorative Wall End for 15" Depth	3/16" x 14 1/4" x 36"	None	Exterior	Raw	Veneer
DWEP1542 *	Decorative Wall End	3/16" x 14 1/4" x 42"	None	Exterior	Raw	Veneer

End Panel Columns

NOTES ✓

- ▶ All End Panel Columns feature an attached 3/8" laminate finished end panel.
- ▶ Designed for use in Base applications.
- ▶ End Panel Columns are available in Cherry, Maple, and White/Antique finishes only.
- ▶ Field measure for countertops is recommended due to the unique profile on the end panel filler.

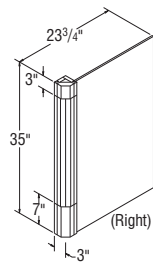

(Fluted) Base  
**EPCBFL35\***

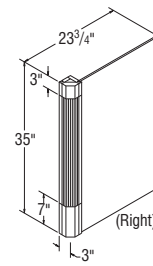
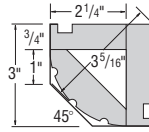

(Reeded) Base  
**EPCBRE35\***

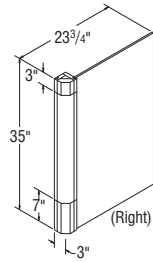
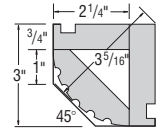

(Round) Base  
**EPCBRD35\***

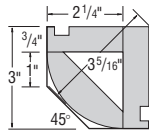

\*Specify L or R to indicate panel location.

Range Panel, 35" High

NOTES ✓

- ▶ Rail, Panel, and Toekick.
- ▶ 27" opening.

DESIGN SOLUTIONS

- ▶ Use drawer front to cover bottom portion of panel.

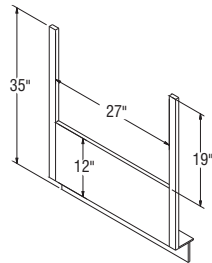

**RP30**

## ToeKick

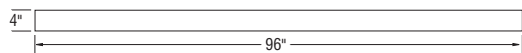

**TOEKICK8**  
**TOEKICK**



Panel	Description	Size (T x W x H)	Edge Finish	Color Side 1	Color Side 2	Finish
TOEKICK8	Aristex™ ToeKick	1/4" x 4" x 96"	None	Exterior	Raw	Laminate
TOEKICK	Aristex™ ToeKick	1/4" x 4" x 96"	None	Exterior	Raw	Laminate

## ToeKick Cap

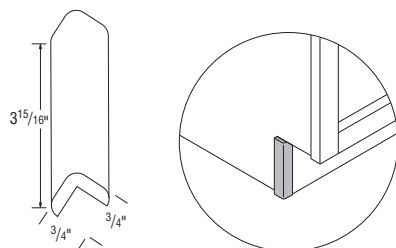

**TKC**

### NOTES ✓

- ▶ TKC dimension:  
3/4" x 4" x 3/4"
- ▶ Sold in pairs.

## Exterior Shelves

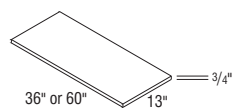

**WSS36 (2/ctn.)**  
**WSS60 (2/ctn.)**



Shelf	Description	Size (T x W x D)	Edge Finish	Color Side 1	Color Side 2	Finish
WSS36	Wall System Shelves	3/4" x 36" x 13"	1 Long	Exterior	Exterior	Veneer
WSS60	Wall System Shelves	3/4" x 60" x 13"	1 Long	Exterior	Exterior	Veneer

**NOTES** ✓

- ▶ Recommended for use with Bookcase units where loads on shelves will exceed over 60 lbs.
- ▶ One Shelf Kit required per shelf.
- ▶ When ordered in a Rustic Birch style, will not feature rustic characteristics.

**Bookshelf Kit**

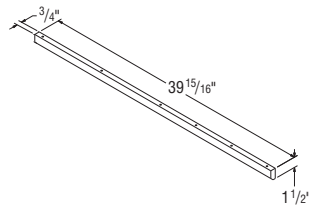

**BKSHELFKIT\***

\*Order under door style number.

**NOTES** ✓

- ▶ AC2417.5 is designed to be used between countertop and Diagonal Wall cabinet.
- ▶ AC2417.5 opening – 12" W x 14 1/2" H.
- ▶ ACS1817.5 opening – 13" W x 14 1/2" H.
- ▶ ACS2417.5 opening – 19" W x 14 1/2" H.
- ▶ ACS3017.5 opening – 25" W x 14 1/2" H.

**Appliance Centers (Under Wall Cabinet Accessory)**

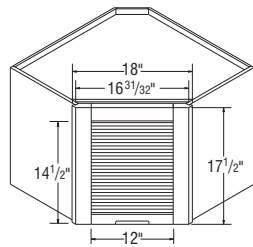

Diagonal

**AC2417.5**

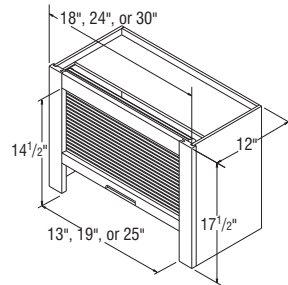

Straight

**ACS1817.5  
ACS2417.5  
ACS3017.5**



**NOTES** ✓

- Designed to be mounted underneath a standard Wall cabinet.
- SGH30 holds 7 rows.
  - SGH36 holds 9 rows.

**Stem Glass Holders (Under Wall Cabinet Accessory)**

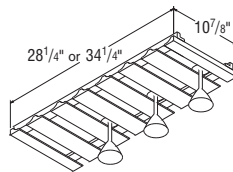

**SGH30  
SGH36**



Side View

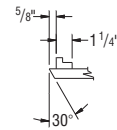

## Organizer Shelves (Under Wall Cabinet Accessory)

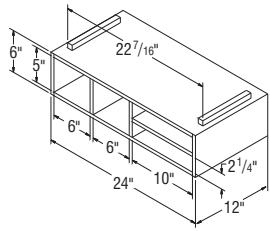

**ORG24**

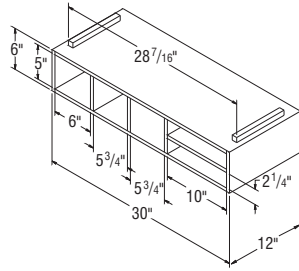

**ORG30**

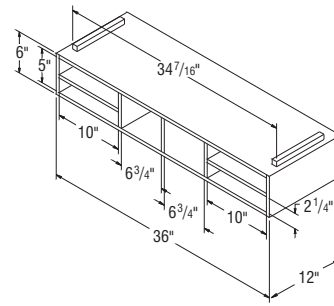

**ORG36**

### NOTES ✓

- ▶ Designed to mount underneath Wall cabinet.
- ▶ Top, bottom, and sides are finished.



## Stem Glass Holders (Wall Open Cabinet Accessory)

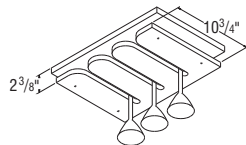

**SGH18**  
**SGH21**

### NOTES ✓

- ▶ One 3/4" thick matching Aristex™ shelf mounted to each Stem Glass Holder.
- ▶ Stem Glass Holder is installed by placing shelf in position with included shelf clips.
- ▶ SGH18 fits 18" wide Wall cabinets.
- ▶ SGH21 fits 21" wide Wall cabinets.



**NOTES** ✓

- ▶ Will only mount inside of Open Wall cabinets. Cannot be used underneath cabinets.
- ▶ Apothecary Drawer is mounted in a 1/2" standard laminated case (natural maple color), and comes complete with side-mounted Full-Extension drawer guide system.
- ▶ One 3/4" notched matching Aristex™ shelf included with each Apothecary Drawer to place on top of case to give it a finished look.
- ▶ Units have a simulated three-panel drawer front, except the following:

SLAB	5-PIECE
Augusta	Briarcliff II
Ellsworth	Durham
	Overton

- ▶ Does not include decorative hardware on any style.
- ▶ Only available in Standard construction (not available as wood dovetail).
- ▶ APDWR18 fits 18" wide Wall cabinet.
- ▶ APDWR21 fits 21" wide Wall cabinet.



## Apothecary Drawers (Wall Open Cabinet Accessory)

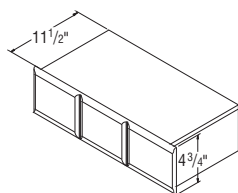

**APDWR18\***  
**APDWR21\***

\*Order under door style number, not common style number.

**NOTES** ✓

- ▶ Natural wood finish with chrome bars.
- ▶ Designed for Wall cabinets (30", 36", and 42" high), Base cabinets, Utility cabinets, and Linen Closet cabinets. Make sure to avoid interference with roll trays, full depth shelves, or other interior cabinet accessories.
- ▶ Mounts to door frame.
- ▶ Order under style #010.

**DESIGN SOLUTIONS**

- ▶ Great for use in the bathroom to hold vitamins, medications, etc.



## Wall Spice Racks (Wall Cabinet Accessory)

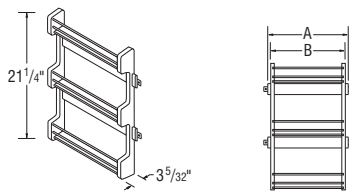

**SRD15**  
**SRD18**  
**SRD21**

Model	Recommended	A Dimension	B Dimension
SRD15	15" or 30" wide	10 1/2"	9 1/2" wide
SRD18	18" or 36" wide	13 1/2"	12 1/2" wide
SRD21	21" or 42" wide	16 1/2"	15 1/2" wide

## Pegged Dish Organizer (Drawer Accessory)

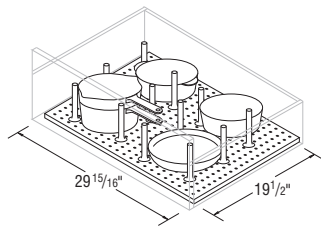

**PDO**



**PDOPOSTS**

### NOTES ✓

- ▶ PDO includes 8 wooden posts and board.
- ▶ PDOPOSTS includes 4 wooden posts.
- ▶ Pegged board is  $\frac{3}{8}$ " thick.
- ▶ Recommended for use in DB36, DB36-4, DBFP36, and DBFP36-4. Pegged board can be trimmed for use in smaller applications.
- ▶ Order under style #010.



## Cutlery Trays (Drawer Accessory)

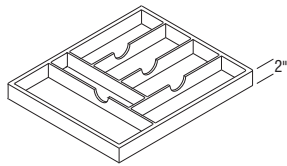

**CT15**      **CT21**  
**CT15UM**   **CT21UM**  
**CT18**      **CT24**  
**CT18UM**   **CT24UM**

Model	Width	Depth	Usage Details
CT15	9 <sup>27</sup> / <sub>32</sub> "	18 <sup>15</sup> / <sub>16</sub> "	20" deep furniture board drawers
CT15UM	9 <sup>15</sup> / <sub>16</sub> "	19 <sup>9</sup> / <sub>16</sub> "	21" deep undermount dovetail drawers
CT18	12 <sup>27</sup> / <sub>32</sub> "	18 <sup>15</sup> / <sub>16</sub> "	20" deep furniture board drawers
CT18UM	12 <sup>15</sup> / <sub>16</sub> "	19 <sup>9</sup> / <sub>16</sub> "	21" deep undermount dovetail drawers
CT21	15 <sup>27</sup> / <sub>32</sub> "	18 <sup>15</sup> / <sub>16</sub> "	20" deep furniture board drawers
CT21UM	15 <sup>15</sup> / <sub>16</sub> "	19 <sup>9</sup> / <sub>16</sub> "	21" deep undermount dovetail drawers
CT24	18 <sup>27</sup> / <sub>32</sub> "	18 <sup>15</sup> / <sub>16</sub> "	20" deep furniture board drawers
CT24UM	18 <sup>15</sup> / <sub>16</sub> "	19 <sup>9</sup> / <sub>16</sub> "	21" deep undermount dovetail drawers

### NOTES ✓

- ▶ Cutlery Trays are standard on Drawer Base cabinets 15"–24" wide.
- ▶ All Cutlery Trays are white plastic.
- ▶ Order under style #010.



## Cutting Board Kit (Drawer Accessory)

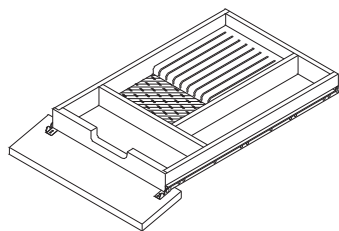

Cutlery Kit

**CBK\***

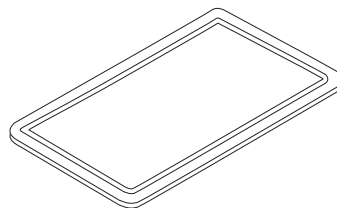

Cutting Board

### NOTES ✓

- ▶ CBK contains Cutlery Drawer, drawer front, drawer frame assembly, and Cutting Board.
- ▶ CBK can be field installed for B18, B36, DB18 and DB18-4. Not compatible with B36B.



\*Order under door style number.

**NOTES** ✓

- ▶ Meets KCMA standards of 15 lbs. per square foot.
- ▶ Cannot be trimmed.
- ▶ Kit includes two 1/4" thick tempered glass shelves and shelf clips.
- ▶ Order under style #010.



**Glass Shelf Kits, 12" Deep**

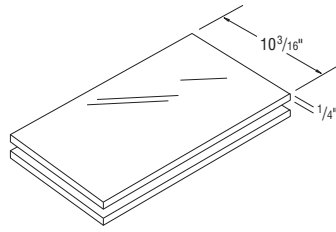

- GSK1512**
- GSK1812**
- GSK2112**
- GSK2412**
- GSK3012**
- GSK3612**

**NOTES** ✓

- ▶ Meets KCMA standards of 15 lbs. per square foot.
- ▶ Can not be trimmed.
- ▶ Kit includes two 1/4" thick tempered glass shelves and shelf clips.
- ▶ Order under style #010.



**Glass Shelf Kits, Diagonal**

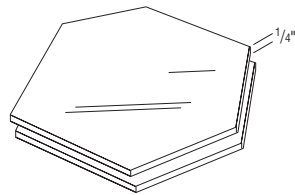

Fits DC...24  
**GSKDC24**

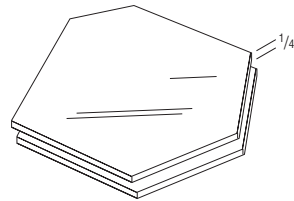

Fits DC...27  
**GSKDC27**

## Heat Shield, Angled

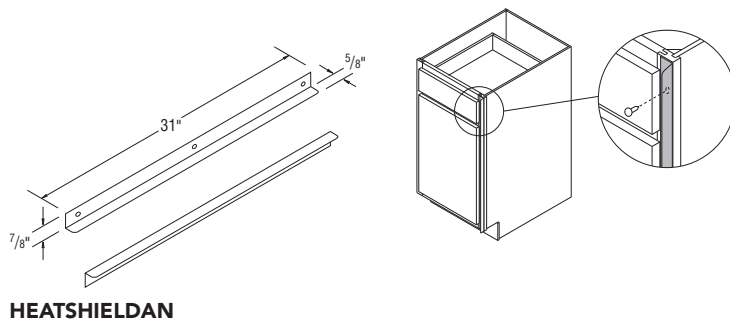

**HEATSHIELDAN**

### NOTES ✓

- ▶ Sold in pairs.
- ▶ Used to deflect heat from self-cleaning ovens, away from cabinet doors and drawer fronts.
- ▶ Includes installation screws.
- ▶ White finish.
- ▶ For use on cabinets next to an oven/range when an additional 1/8" cannot be added to the oven manufacturer's recommended space requirement between the oven and each adjacent cabinet.
- ▶ Cabinet door cannot be hinged on the same side as the angled heat shield, not compatible with double door cabinets.
- ▶ Installs on the front of the face frame of each cabinet adjacent to the oven.



## Heat Shield, Straight

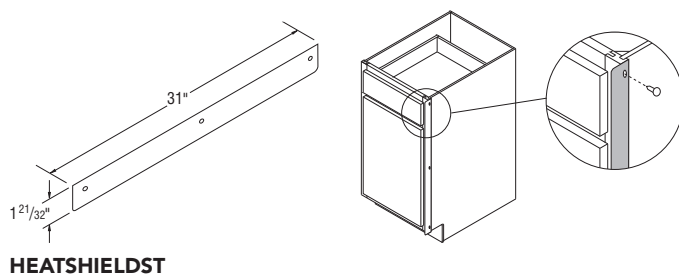

**HEATSHIELDST**

### NOTES ✓

- ▶ Sold in pairs.
- ▶ Used to deflect heat from self-cleaning ovens, away from cabinet doors and drawer fronts.
- ▶ Includes installation screws.
- ▶ White finish.
- ▶ For use on cabinets next to an oven/range when an additional 1/8" can be added to the oven manufacturer's recommended space requirement.
- ▶ Installs on the side of the face frame of each cabinet adjacent to the oven.



**NOTES** ✓

- ▶ Two metal brackets to support ovens and microwaves.
- ▶ Designed to be used with OC and OCD cabinets.
- ▶ Cabinet not included.
- ▶ Order under style #010.

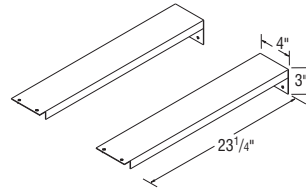
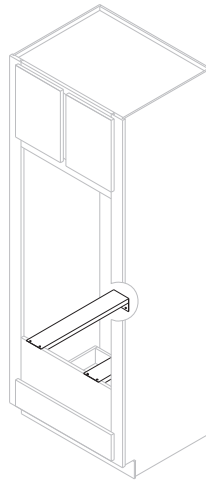
**OCINSTALLKIT****Oven Installation Kit**

PRODUCT CODES	Dimensions	Natural Maple Laminate	White Laminate	Plywood	Fits 12" Deep	Fits 24" Deep
---------------	------------	------------------------	----------------	---------	---------------	---------------

## Pantry Shelf Kits

PKS15C	13½" x 22½"	✓				✓
PKS15CWH	13½" x 22½"		✓			✓
PKS18C	16½" x 22½"	✓				✓
PKS18CWH	16½" x 22½"		✓			✓
PKS24C	22½" x 22½"	✓				✓
PKS24CWH	22½" x 22½"		✓			✓
PKS30C	28½" x 22½"	✓				✓
PKS30CWH	28½" x 22½"		✓			✓
PKS36C	34½" x 22½"	✓				✓
PKS36CWH	34½" x 22½"		✓			✓
PKS1512C	13½" x 10 <sup>11</sup> / <sub>32</sub> "	✓			✓	
PKS1512CWH	13½" x 10 <sup>11</sup> / <sub>32</sub> "		✓		✓	
PKS1812C	16½" x 10 <sup>11</sup> / <sub>32</sub> "	✓			✓	
PKS1812CWH	16½" x 10 <sup>11</sup> / <sub>32</sub> "		✓		✓	
PKS2412C	22½" x 10 <sup>11</sup> / <sub>32</sub> "	✓			✓	
PKS2412CWH	22½" x 10 <sup>11</sup> / <sub>32</sub> "		✓		✓	
PKS3012C	28½" x 10 <sup>11</sup> / <sub>32</sub> "	✓			✓	
PKS3012CWH	28½" x 10 <sup>11</sup> / <sub>32</sub> "		✓		✓	
PKS3612C	34½" x 10 <sup>11</sup> / <sub>32</sub> "	✓			✓	
PKS3612CWH	34½" x 10 <sup>11</sup> / <sub>32</sub> "		✓		✓	
PKS15CPL	13½" x 22½"	✓		✓		✓
PKS15CWHPL	13½" x 22½"		✓	✓		✓
PKS18CPL	16½" x 22½"	✓		✓		✓
PKS18CWHPL	16½" x 22½"		✓	✓		✓
PKS24CPL	22½" x 22½"	✓		✓		✓
PKS24CWHPL	22½" x 22½"		✓	✓		✓
PKS30CPL	28½" x 22½"	✓		✓		✓
PKS30CWHPL	28½" x 22½"		✓	✓		✓
PKS36CPL	34½" x 22½"	✓		✓		✓
PKS36CWHPL	34½" x 22½"		✓	✓		✓
PKS1512CPL	13½" x 10 <sup>11</sup> / <sub>32</sub> "	✓		✓	✓	
PKS1512CWHPL	13½" x 10 <sup>11</sup> / <sub>32</sub> "		✓	✓	✓	
PKS1812CPL	16½" x 10 <sup>11</sup> / <sub>32</sub> "	✓		✓	✓	
PKS1812CWHPL	16½" x 10 <sup>11</sup> / <sub>32</sub> "		✓	✓	✓	
PKS2412CPL	22½" x 10 <sup>11</sup> / <sub>32</sub> "	✓		✓	✓	
PKS2412CWHPL	22½" x 10 <sup>11</sup> / <sub>32</sub> "		✓	✓	✓	
PKS3012CPL	28½" x 10 <sup>11</sup> / <sub>32</sub> "	✓		✓	✓	
PKS3012CWHPL	28½" x 10 <sup>11</sup> / <sub>32</sub> "		✓	✓	✓	
PKS3612CPL	34½" x 10 <sup>11</sup> / <sub>32</sub> "	✓		✓	✓	
PKS3612CWHPL	34½" x 10 <sup>11</sup> / <sub>32</sub> "		✓	✓	✓	

Shelves shown on next page.

### NOTES ✓

- ▶ Pantry Shelf Kits contain four shelves and sixteen clips.
- ▶ Shelves are ¾" thick.
- ▶ Maximum weight per square foot is 15 lbs.
- ▶ Pantry Shelf Kits are natural maple laminate or specify PKS\_ \_WH for white.
- ▶ Order under style #010.



**NOTES** ✓

- ▶ Pantry Roll Tray Kits feature 1/2" thick solid wood front and furniture board sides and back, or specify UPK\_ \_WH for white.
- ▶ Pantry Roll Tray Kits contain four trays, eight suspension tracks, eight corner standards, and installation screws.
- ▶ Maximum weight per square foot is 15 lbs.
- ▶ Pantry Roll Tray Kits cannot be used in any Utility cabinet 12" deep.
- ▶ Order under style #010.

**DESIGN SOLUTIONS**

- ▶ Shelf or Roll Tray Kits can be used to convert a standard Utility cabinet into a Pantry.



## Pantry Roll Tray Kit

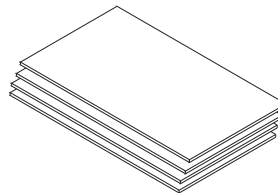
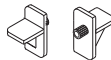
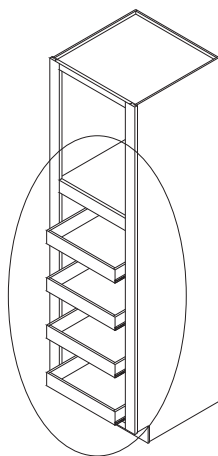

Pantry Roll Tray Kit

Pantry Shelf Kit Clips

Pantry Shelf Kit Shelves

**UPK15**

**UPK15WH**

**UPK18**

**UPK18WH**

**UPK24**

**UPK24WH**

**UPK30**

**UPK30WH**

**UPK36**

**UPK36WH**

Model	Dimensions	Natural Maple Laminate	White Laminate	Thickness
UPK15	10 <sup>11</sup> / <sub>16</sub> " x 20 <sup>3</sup> / <sub>16</sub> "	✓		3 <sup>1</sup> / <sub>8</sub> "
UPK15WH	10 <sup>11</sup> / <sub>16</sub> " x 20 <sup>3</sup> / <sub>16</sub> "		✓	3 <sup>1</sup> / <sub>8</sub> "
UPK18	13 <sup>11</sup> / <sub>16</sub> " x 20 <sup>3</sup> / <sub>16</sub> "	✓		3 <sup>1</sup> / <sub>8</sub> "
UPK18WH	13 <sup>11</sup> / <sub>16</sub> " x 20 <sup>3</sup> / <sub>16</sub> "		✓	3 <sup>1</sup> / <sub>8</sub> "
UPK24	19 <sup>11</sup> / <sub>16</sub> " x 20 <sup>3</sup> / <sub>16</sub> "	✓		3 <sup>1</sup> / <sub>8</sub> "
UPK24WH	19 <sup>11</sup> / <sub>16</sub> " x 20 <sup>3</sup> / <sub>16</sub> "		✓	3 <sup>1</sup> / <sub>8</sub> "
UPK30	25 <sup>11</sup> / <sub>16</sub> " x 20 <sup>3</sup> / <sub>16</sub> "	✓		3 <sup>1</sup> / <sub>8</sub> "
UPK30WH	25 <sup>11</sup> / <sub>16</sub> " x 20 <sup>3</sup> / <sub>16</sub> "		✓	3 <sup>1</sup> / <sub>8</sub> "
UPK36	31 <sup>11</sup> / <sub>16</sub> " x 20 <sup>3</sup> / <sub>16</sub> "	✓		3 <sup>1</sup> / <sub>8</sub> "
UPK36WH	31 <sup>11</sup> / <sub>16</sub> " x 20 <sup>3</sup> / <sub>16</sub> "		✓	3 <sup>1</sup> / <sub>8</sub> "

**NOTES** ✓

- ▶ Roll Tray Kits feature 1/2" thick solid wood front and furniture board sides and back, or specify TKIT\_ \_WH for white.
- ▶ Maximum weight per square foot is 15 lbs.
- ▶ All guides are white.
- ▶ Order under style #010.
- ▶ No TKIT available for B27 or B33.
- ▶ See Storage Accessories Matrix on pages 167 & 168.

**DESIGN SOLUTIONS**

- ▶ An additional Roll Out Tray can be installed above the Base cabinet half-depth shelf.



## Roll Tray Kits

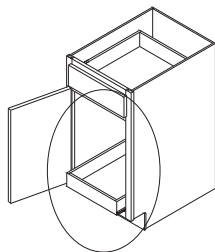

**TKIT15**

**TKIT15WH**

**TKIT18**

**TKIT18WH**

**TKIT21**

**TKIT21WH**

**TKIT24**

**TKIT24WH**

**TKIT27**

**TKIT27WH**

**TKIT30**

**TKIT30WH**

**TKIT33**

**TKIT33WH**

**TKIT36**

**TKIT36WH**

**TKIT39**

**TKIT39WH**

**TKIT45**

**TKIT45WH**

Model	Recommended Width of Face Frame Opening	Trays	Track Sliders	Mounting Blocks	2 1/2" Wood Screws	5/8" Wood Screws	1/8" Spacers
TKIT15	12"	1	2	2	2	4	2
TKIT15WH	12"	1	2	2	2	4	2
TKIT18	15"	1	2	2	2	4	2
TKIT18WH	15"	1	2	2	2	4	2
TKIT21	18"	1	2	2	2	4	2
TKIT21WH	18"	1	2	2	2	4	2
TKIT24	21"	1	2	2	2	4	2
TKIT24WH	21"	1	2	2	2	4	2
TKIT27	24"	1	2	2	2	4	2
TKIT27WH	24"	1	2	2	2	4	2
TKIT30	27"	1	2	2	2	4	2
TKIT30WH	27"	1	2	2	2	4	2
TKIT33	30"	1	2	2	2	4	2
TKIT33WH	30"	1	2	2	2	4	2
TKIT36	33"	1	2	2	2	4	2
TKIT36WH	33"	1	2	2	2	4	2
TKIT39	16 1/2"	2	4	4	2	8	2
TKIT39WH	16 1/2"	2	4	4	2	8	2
TKIT45	19 1/2"	2	4	4	2	8	2
TKIT45WH	19 1/2"	2	4	4	2	8	2

## Roll Tray Bumper Pads

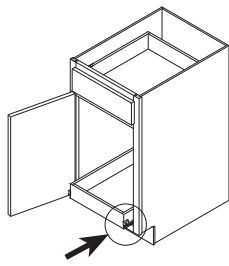

RTBP

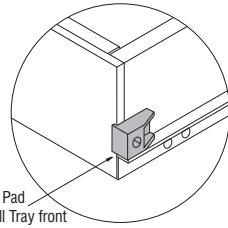

Place Bumper Pad on edge of Roll Tray front on top of Roll Tray Slide.

### NOTES ✓

- ▶ Includes two bumpers, two screws.
- ▶ Use to protect door from Roll Tray corner.
- ▶ Order under style #010.



## Double Wastebasket Roll Out

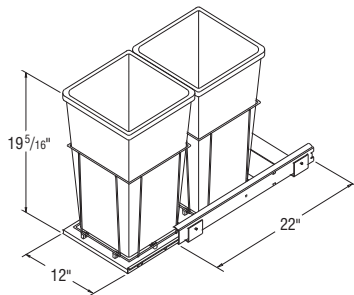

DWBR\*

\*Fits 15" wide Base cabinet.

### NOTES ✓

- ▶ White epoxy coated wire with Full Extension guides.
- ▶ Includes two 27 quart Wastebaskets with wire storage compartment.
- ▶ Mounted on white melamine board and installs to floor of cabinet.
- ▶ Order under style #010.
- ▶ Installation of this accessory requires removing half-depth shelf. See matrix on pages 167 & 168 for installation recommendations.



## Sink Tip-Out Trays

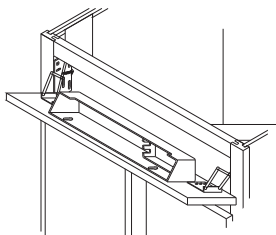

STOT30WH  
STOT36WH  
STOT30WHB  
STOT36WHB

Model	Cabinet Width	Description
STOT30WH	30"	two 11½" white trays, 4 hinges
STOT36WH	36"	two 14½" white trays, 4 hinges
STOT30WHB	30"	two 11½" white trays, 2 hinges
STOT36WHB	36"	two 14½" white trays, 2 hinges

### NOTES ✓

- ▶ Pulls to add to the false front must be ordered separately.
- ▶ If STOTs are used on a full overlay style, it is recommended that a pull be used.
- ▶ STOT30WH & STOT36WH are for cabinets with two false fronts.
- ▶ STOT30WHB & STOT36WHB are for cabinets with one false front.
- ▶ Two white trays, 2¼" deep.
- ▶ Order under style #010.
- ▶ See Storage Accessory Matrix on pages 167 & 168.



## NOTES ✓

- ▶ Creates a smooth and silent closing motion.
- ▶ Recommended usage per cabinet: 1 per door on any door with 2 hinges and 2 per door on any door with 3 or more hinges (cabinets under 36" high have 2 hinges, 36" and higher have 3 hinges). Additional units may be required when an accessory item is attached to the cabinet door.
- ▶ Not recommended for use on bi-fold doors or Base SuperCabinets™.



## Smart Stop Door Mechanism

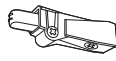

SSDM

## NOTES ✓

- ▶ HINGE6WAY is used on all door styles.
- ▶ SPACER4 includes (4) 1/32" hinge spacers, and is used for field hinge adjustments.

## Hinges

HINGE6WAY\*  
SPACER4

\*Order under door style number.

# Stain, Toner, and Touch-Up

NOTES ✓

Touch-Up Kit

**TUKIT\***

- ▶ Order 1 pint of Toner for 1 quart of Stain.
- ▶ For white and antique styles, Touch-Up is only recommended for face frames and End Panels.
- ▶ Use Maple/Birch for Rustic finishes.



Pint of Toner

**TONERPT\*\***



Pint of Stain

**STAINPT\*\***

Quart of Stain

**STAINQT\*\***

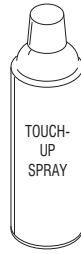

Touch-Up Spray Can

**TUPSPRAY**

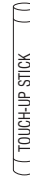

Touch-Up Stick

**TUPSTICK\*\*\***

\*Touch-Up Kit contains one felt marker and one putty stick.

\*\*TONEPT, STAINPT, and STAINQT are not available in White or Antique.

\*\*\*Touch-Up Stick – when ordering TUPSTICK, a single putty stick in the selected color is sent.

Wood Type	Color	TONERPT Required	STAINPT or STAINQT Required
Cherry	Café	✓	✓
	Cocoa Glaze	✓	✓
	Java Glaze	✓	✓
	Rouge	✓	✓
	Saddle	✓	✓
	Umber	✓	✓
Hickory	Wheat	•	✓
	Saddle	✓	✓
Maple	Wheat	•	✓
	Java Glaze	✓	✓
Maple/Birch	Autumn	✓	✓
	Café	✓	✓
	Cocoa Glaze	✓	✓
	Fawn	✓	•
	Rouge	✓	✓
	Saddle	✓	✓
	Sarsaparilla	✓	✓
Oak	Umber	✓	✓
	Saddle	✓	✓
	Sarsaparilla	✓	✓
	Spice	✓	✓
	Wheat	•	✓

## Trim Items with Rustic Characteristics

Use Rustic Common Style Numbers to order items with Rustic Characteristics.  
For all other trim items, use Maple Common Style Numbers (see page 7).

Product Code	Description	Page #
BBCPO6 <i>New</i>	Base Box Column Pullout Cabinet	81
MCROWN_	Moulding Crown	136
MICROWN_	Moulding Insert Crown	136
MFOLCR_	Moulding Full Overlay Crown	136
MTCROWN8	Moulding Tall Crown	136
MSHKRCROWN_	Moulding Shaker Crown	136
MBS_	Moulding Base Shoe	140
FBC3X3	Filler - Base Corner	141
F3_ & F6_	Filler - Base & Tall Straight	141
V_ _ _ RA & V_ _ _ ST	Valance - Arch & Straight	147
PDWP	Dishwasher Front Panel	148
PEPR335 **	Aristex™ End Panel with 3" Stile	148
PEPRPLY_ _35 *	Plywood End Panel with 1½" or 3" Stile	148
PREF23_ _	Plywood Refrigerator End Panel	148
PREPRP_ _ _ _ *	Plywood Refrigerator End Panel with 1½" Stile	148
PREPR33096	Veneer Furniture Board Refrigerator End Panel with 3" Stile	148
PP9635	Stock Panel	149
P48_ _	Stock Panel	149
EPV_ _ _ _ <i>New</i>	Veneer End Panel	150

\*\* Rustic characteristics on PEPR335 Filler only.

\* Rustic characteristics on PEPRPLY1.535, PREPRP1.584, and PREPRP1.596 panels only.

## Trim Items Available in Toasted Antique (Common Style #199)

Product Code	Description	Page #
F531A45	Decorative Fluted Angle Filler	141
FF396	Reeded Tall Filler, 3" Wide	141
FFROS3X3	Rosette	143
MFOLCR8	Full Overlay Crown Moulding	136
MICROWN8	Insert Crown Moulding	136
MTBEAD8	Triple Bead Moulding	135
MTCAP8	Traditional Cap Moulding	139
MTCROWN8	Tall Crown Moulding	136
MTLR8	Tall Light Rail Moulding	139
MTST8	Traditional Soffit Trim Moulding	138

# Traditional Storage Accessory Matrix

NOTES 

Cabinet	Double Wastebasket Roll Out	STOT30WH Sink Tip-Out Tray 30" Two 11 1/2" trays, 4 hinges	STOT30WHB Sink Tip-Out Tray 30" Two 11 1/2" trays, 2 hinges	STOT36WH Sink Tip-Out Tray 36" Two 14 1/2" trays, 4 hinges	STOT36WHB Sink Tip-Out Tray 36" Two 14 1/2" trays, 2 hinges	Roll Out Kit*
B12	•	•	•	•	•	•
B15	H	•	•	•	•	TKIT15
B15RT	•	•	•	•	•	TKIT15
B18	H	•	•	•	•	TKIT18
B18RT	•	•	•	•	•	TKIT18
B21	H	•	•	•	•	TKIT21
B21RT	•	•	•	•	•	TKIT21
B24	H	•	•	•	•	TKIT24
B24RT	•	•	•	•	•	TKIT24
B24DD	H	•	•	•	•	TKIT24
B24DDRT	•	•	•	•	•	TKIT24
B27	•	•	•	•	•	•
B27B	•	•	•	•	•	TKIT27
B27RT	•	•	•	•	•	TKIT27
B27RTB	•	•	•	•	•	TKIT27
B30	H	•	•	•	•	TKIT15
B30B	H	•	•	•	•	TKIT30
B30RT	•	•	•	•	•	TKIT30
B30RTB	•	•	•	•	•	TKIT30
B33	H	•	•	•	•	•
B33B	H	•	•	•	•	TKIT33
B33RT	•	•	•	•	•	TKIT33
B33RTB	•	•	•	•	•	TKIT33
B36	H	•	•	•	•	TKIT18
B36B	H	•	•	•	•	TKIT36
B36RT	•	•	•	•	•	TKIT36
B36RTB	•	•	•	•	•	TKIT36
B39	H	•	•	•	•	TKIT39
B39RT	•	•	•	•	•	TKIT39
B42	H	•	•	•	•	TKIT21
B42RT	•	•	•	•	•	TKIT21
B45	H	•	•	•	•	TKIT45
B45RT	•	•	•	•	•	TKIT45
B48	H	•	•	•	•	TKIT24
B48RT	•	•	•	•	•	TKIT24
B15FH	✓	•	•	•	•	TKIT15
B18FH	I	•	•	•	•	TKIT18
B21FH	I	•	•	•	•	TKIT21
B24FH	I	•	•	•	•	TKIT24
B30FH	✓	•	•	•	•	TKIT15
B30FHB	I	•	•	•	•	TKIT30
B36FH	I	•	•	•	•	TKIT18
B36FHB	I	•	•	•	•	TKIT36
BWB15FH	•	•	•	•	•	•
BWB18	•	•	•	•	•	•
BWB21	•	•	•	•	•	•
SCB36	•	•	•	•	•	•
SCB39	H	•	•	•	•	•
SCB42	H	•	•	•	•	•
SCB45	H	•	•	•	•	•
SCB48	H	•	•	•	•	TKIT21
SCER36	•	•	•	•	•	•
SB24	P	I <sup>†</sup>	•	I <sup>†</sup>	•	TKIT24
SB24DD	P	I <sup>†</sup>	•	I <sup>†</sup>	•	TKIT24
SB27	P	I <sup>†</sup>	•	I <sup>†</sup>	•	TKIT27
SB27B	P	I <sup>†</sup>	•	•	•	TKIT27
SB30	P	✓	•	•	•	TKIT15
SB30B	P	•	✓	•	•	TKIT30

**KEY**

- F** Must remove full-depth shelf.
- H** Must remove half-depth shelf.
- I** Can be installed without modification to cabinet.
- P** Location of plumbing should be checked prior to installation of storage accessory.
- ✓ Recommended for ideal fit, and can be installed without modification to cabinet.
- Not applicable.
- \* Roll Out Kits also available in white, specify TKIT\_\_WH.
- † Only one tray will fit.

## Traditional Storage Accessory Matrix

**KEY**

- F** Must remove full-depth shelf.
- H** Must remove half-depth shelf.
- I** Can be installed without modification to cabinet.
- P** Location of plumbing should be checked prior to installation of storage accessory.
- ✓ Recommended for ideal fit, and can be installed without modification to cabinet.
- Not applicable.
- \* Roll Out Kits also available in white, specify TKIT\_ \_WH.
- † Only one tray will fit.

Cabinet	Double Wastebasket Roll Out	STOT30WH Sink Tip-Out Tray 30" Two 11 1/2" trays, 4 hinges	STOT30WHB Sink Tip-Out Tray 30" Two 11 1/2" trays, 2 hinges	STOT36WH Sink Tip-Out Tray 36" Two 14 1/2" trays, 4 hinges	STOT36WHB Sink Tip-Out Tray 36" Two 14 1/2" trays, 2 hinges	Roll Out Kit*
SB33	P	I	•	•	•	•
SB33B	P	•	✓	•	•	TKIT33
SB36	P	I	•	✓	•	TKIT18
SB36B	P	•	I	•	✓	TKIT36
SB39	P	I	•	I	•	TKIT39
SB42	P	I	•	I	•	TKIT21
SB45	P	I	•	I	•	TKIT45
SB48	P	I	•	I	•	TKIT24
SBDC36	P	I <sup>†</sup>	•	•	•	•
SBDC42	P	I <sup>†</sup>	•	I <sup>†</sup>	•	•
SF30 (POL)	P	I <sup>†</sup>	•	I <sup>†</sup>	•	•
SF30 (FOL)	P	I	•	•	•	•
SF36 (POL)	P	✓	•	•	•	•
SF36 (FOL)	P	I	•	✓	•	•
SF36B (POL)	P	•	I	•	•	•
SF36B (FOL)	P	•	I	•	✓	•
SF42	P	I	•	✓	•	•
SF48	P	I	•	I	•	•
SFC36	P	I <sup>†</sup>	•	•	•	•
SFC42	P	I <sup>†</sup>	•	I <sup>†</sup>	•	•
PB18	F	•	•	•	•	•
PB24	F	•	•	•	•	•
PB24DD	F	•	•	•	•	•
PB30	F	•	•	•	•	•
PB30B	F	•	•	•	•	•
PB36	F	•	•	•	•	•
PB36B	F	•	•	•	•	•
PB42	F	•	•	•	•	•
PB48	F	•	•	•	•	•
PBSC27	F	•	•	•	•	•
PBSC27B	F	•	•	•	•	•
PBSC42	F	•	•	•	•	•
PBSC48	F	•	•	•	•	•
U15/U1590/U1596	I	•	•	•	•	TKIT15
U18/U1890/U18596	I	•	•	•	•	TKIT18
U24/U2490/U2496	I	•	•	•	•	TKIT24
U30/U3090/U3096	I	•	•	•	•	TKIT30
U30B/U3090B/U3096B	I	•	•	•	•	TKIT30
U36/U3690/U3696	I	•	•	•	•	TKIT36
U36B/U3690B/U3696B	I	•	•	•	•	TKIT36
B24DDFH32.5	I	•	•	•	•	TKIT24
B30FH32.5	I	•	•	•	•	TKIT15
B30FH32.5B	I	•	•	•	•	TKIT30
B33FH32.5	I	•	•	•	•	•
B33FH32.5B	I	•	•	•	•	TKIT33
B36FH32.5	I	•	•	•	•	TKIT18
B36FH32.5B	I	•	•	•	•	TKIT36
SB3032.5	•	✓	•	•	•	TKIT15
SB3032.5B	•	•	✓	•	•	TKIT30
SB3632.5	•	I	•	✓	•	TKIT18
SB3632.5B	•	•	I	•	✓	TKIT36
U1832.5	I	•	•	•	•	TKIT18
U2432.5	I	•	•	•	•	TKIT24

# Glass Size Chart for Wall Prepped for Glass Cabinets

	Butt Doors		Butt Doors		Butt Doors		Butt Doors		Butt Doors		Butt Doors		Butt Doors		Center Mullion Doors	
	Briarcliff II Dryden Durham Eastland Wentworth		Ellisworth		Harrison Winstead		Saybrooke		Benton		Grayson Landen		Ayden Radford		Avalon Oakland Pioneer Sinclair Westbury	
	Width	Height	Width	Height	Width	Height	Width	Height	Width	Height	Width	Height	Width	Height	Width	Height
<b>RECOMMENDED GLASS SIZES</b>																
WPG1542	9 <sup>5</sup> / <sub>8</sub> "	36 <sup>5</sup> / <sub>8</sub> "	10 <sup>13</sup> / <sub>16</sub> "	37 <sup>13</sup> / <sub>16</sub> "	10 <sup>7</sup> / <sub>8</sub> "	37 <sup>7</sup> / <sub>8</sub> "	9 <sup>7</sup> / <sub>8</sub> "	36 <sup>1</sup> / <sub>4</sub> "	9 <sup>7</sup> / <sub>8</sub> "	36 <sup>1</sup> / <sub>4</sub> "	8 <sup>7</sup> / <sub>8</sub> "	35 <sup>5</sup> / <sub>8</sub> "	9 <sup>5</sup> / <sub>8</sub> "	36 <sup>5</sup> / <sub>8</sub> "	9 <sup>5</sup> / <sub>8</sub> "	36 <sup>5</sup> / <sub>8</sub> "
WPG3042	9 <sup>5</sup> / <sub>8</sub> "	36 <sup>5</sup> / <sub>8</sub> "	10 <sup>13</sup> / <sub>16</sub> "	37 <sup>13</sup> / <sub>16</sub> "	10 <sup>7</sup> / <sub>8</sub> "	37 <sup>7</sup> / <sub>8</sub> "	9 <sup>7</sup> / <sub>8</sub> "	36 <sup>1</sup> / <sub>4</sub> "	9 <sup>7</sup> / <sub>8</sub> "	36 <sup>1</sup> / <sub>4</sub> "	8 <sup>7</sup> / <sub>8</sub> "	35 <sup>5</sup> / <sub>8</sub> "	9 <sup>5</sup> / <sub>8</sub> "	36 <sup>5</sup> / <sub>8</sub> "	9 <sup>5</sup> / <sub>8</sub> "	36 <sup>5</sup> / <sub>8</sub> "
WPG3042B	9 <sup>13</sup> / <sub>16</sub> "	36 <sup>5</sup> / <sub>8</sub> "	11"	37 <sup>13</sup> / <sub>16</sub> "	11 <sup>1</sup> / <sub>16</sub> "	37 <sup>7</sup> / <sub>8</sub> "	10 <sup>1</sup> / <sub>4</sub> "	36 <sup>1</sup> / <sub>4</sub> "	•	•	9 <sup>7</sup> / <sub>8</sub> "	35 <sup>5</sup> / <sub>8</sub> "	10 <sup>5</sup> / <sub>8</sub> "	36 <sup>5</sup> / <sub>8</sub> "	•	•
WPG1842	12 <sup>5</sup> / <sub>8</sub> "	36 <sup>5</sup> / <sub>8</sub> "	13 <sup>13</sup> / <sub>16</sub> "	37 <sup>13</sup> / <sub>16</sub> "	13 <sup>7</sup> / <sub>8</sub> "	37 <sup>7</sup> / <sub>8</sub> "	12 <sup>1</sup> / <sub>4</sub> "	36 <sup>1</sup> / <sub>4</sub> "	12 <sup>1</sup> / <sub>4</sub> "	36 <sup>1</sup> / <sub>4</sub> "	11 <sup>7</sup> / <sub>8</sub> "	35 <sup>5</sup> / <sub>8</sub> "	12 <sup>2</sup> / <sub>8</sub> "	36 <sup>6</sup> / <sub>8</sub> "	12 <sup>2</sup> / <sub>8</sub> "	36 <sup>6</sup> / <sub>8</sub> "
WPG3642	12 <sup>5</sup> / <sub>8</sub> "	36 <sup>5</sup> / <sub>8</sub> "	13 <sup>13</sup> / <sub>16</sub> "	37 <sup>13</sup> / <sub>16</sub> "	13 <sup>7</sup> / <sub>8</sub> "	37 <sup>7</sup> / <sub>8</sub> "	12 <sup>1</sup> / <sub>4</sub> "	36 <sup>1</sup> / <sub>4</sub> "	12 <sup>1</sup> / <sub>4</sub> "	36 <sup>1</sup> / <sub>4</sub> "	11 <sup>7</sup> / <sub>8</sub> "	35 <sup>5</sup> / <sub>8</sub> "	12 <sup>2</sup> / <sub>8</sub> "	36 <sup>6</sup> / <sub>8</sub> "	12 <sup>2</sup> / <sub>8</sub> "	36 <sup>6</sup> / <sub>8</sub> "
WPG3642B	12 <sup>13</sup> / <sub>16</sub> "	36 <sup>5</sup> / <sub>8</sub> "	14"	37 <sup>13</sup> / <sub>16</sub> "	14 <sup>1</sup> / <sub>16</sub> "	37 <sup>7</sup> / <sub>8</sub> "	13 <sup>1</sup> / <sub>4</sub> "	36 <sup>1</sup> / <sub>4</sub> "	•	•	12 <sup>7</sup> / <sub>8</sub> "	35 <sup>5</sup> / <sub>8</sub> "	13 <sup>3</sup> / <sub>8</sub> "	36 <sup>5</sup> / <sub>8</sub> "	•	•
WPG2142	15 <sup>5</sup> / <sub>8</sub> "	36 <sup>5</sup> / <sub>8</sub> "	16 13/16"	37 <sup>13</sup> / <sub>16</sub> "	16 <sup>7</sup> / <sub>8</sub> "	37 <sup>7</sup> / <sub>8</sub> "	15 <sup>1</sup> / <sub>4</sub> "	36 <sup>1</sup> / <sub>4</sub> "	15 <sup>1</sup> / <sub>4</sub> "	36 <sup>1</sup> / <sub>4</sub> "	14 <sup>7</sup> / <sub>8</sub> "	35 <sup>5</sup> / <sub>8</sub> "	15 <sup>5</sup> / <sub>8</sub> "	36 <sup>5</sup> / <sub>8</sub> "	15 <sup>5</sup> / <sub>8</sub> "	36 <sup>5</sup> / <sub>8</sub> "
WPG2442	18 <sup>5</sup> / <sub>8</sub> "	36 <sup>5</sup> / <sub>8</sub> "	19 <sup>13</sup> / <sub>16</sub> "	37 <sup>13</sup> / <sub>16</sub> "	19 <sup>7</sup> / <sub>8</sub> "	37 <sup>7</sup> / <sub>8</sub> "	18 <sup>1</sup> / <sub>4</sub> "	36 <sup>1</sup> / <sub>4</sub> "	18 <sup>1</sup> / <sub>4</sub> "	36 <sup>1</sup> / <sub>4</sub> "	17 <sup>7</sup> / <sub>8</sub> "	35 <sup>5</sup> / <sub>8</sub> "	18 <sup>8</sup> / <sub>8</sub> "	36 <sup>6</sup> / <sub>8</sub> "	18 <sup>8</sup> / <sub>8</sub> "	36 <sup>6</sup> / <sub>8</sub> "
WPG1536	9 <sup>5</sup> / <sub>8</sub> "	30 <sup>5</sup> / <sub>8</sub> "	10 <sup>13</sup> / <sub>16</sub> "	31 <sup>13</sup> / <sub>16</sub> "	10 <sup>7</sup> / <sub>8</sub> "	31 <sup>7</sup> / <sub>8</sub> "	9 <sup>7</sup> / <sub>8</sub> "	30 <sup>1</sup> / <sub>4</sub> "	9 <sup>7</sup> / <sub>8</sub> "	30 <sup>1</sup> / <sub>4</sub> "	8 <sup>7</sup> / <sub>8</sub> "	29 <sup>5</sup> / <sub>8</sub> "	9 <sup>5</sup> / <sub>8</sub> "	30 <sup>5</sup> / <sub>8</sub> "	9 <sup>5</sup> / <sub>8</sub> "	30 <sup>5</sup> / <sub>8</sub> "
WPG3036	9 <sup>5</sup> / <sub>8</sub> "	30 <sup>5</sup> / <sub>8</sub> "	10 <sup>13</sup> / <sub>16</sub> "	31 <sup>13</sup> / <sub>16</sub> "	10 <sup>7</sup> / <sub>8</sub> "	31 <sup>7</sup> / <sub>8</sub> "	9 <sup>7</sup> / <sub>8</sub> "	30 <sup>1</sup> / <sub>4</sub> "	9 <sup>7</sup> / <sub>8</sub> "	30 <sup>1</sup> / <sub>4</sub> "	8 <sup>7</sup> / <sub>8</sub> "	29 <sup>5</sup> / <sub>8</sub> "	9 <sup>5</sup> / <sub>8</sub> "	30 <sup>5</sup> / <sub>8</sub> "	9 <sup>5</sup> / <sub>8</sub> "	30 <sup>5</sup> / <sub>8</sub> "
WPG3036B	9 <sup>13</sup> / <sub>16</sub> "	30 <sup>5</sup> / <sub>8</sub> "	11"	31 <sup>13</sup> / <sub>16</sub> "	11 <sup>1</sup> / <sub>16</sub> "	31 <sup>7</sup> / <sub>8</sub> "	10 <sup>1</sup> / <sub>4</sub> "	30 <sup>1</sup> / <sub>4</sub> "	•	•	9 <sup>7</sup> / <sub>8</sub> "	29 <sup>5</sup> / <sub>8</sub> "	10 <sup>5</sup> / <sub>8</sub> "	30 <sup>5</sup> / <sub>8</sub> "	•	•
WPG1836	12 <sup>5</sup> / <sub>8</sub> "	30 <sup>5</sup> / <sub>8</sub> "	13 <sup>13</sup> / <sub>16</sub> "	31 <sup>13</sup> / <sub>16</sub> "	13 <sup>7</sup> / <sub>8</sub> "	31 <sup>7</sup> / <sub>8</sub> "	12 <sup>1</sup> / <sub>4</sub> "	30 <sup>1</sup> / <sub>4</sub> "	12 <sup>1</sup> / <sub>4</sub> "	30 <sup>1</sup> / <sub>4</sub> "	11 <sup>7</sup> / <sub>8</sub> "	29 <sup>5</sup> / <sub>8</sub> "	12 <sup>2</sup> / <sub>8</sub> "	30 <sup>6</sup> / <sub>8</sub> "	12 <sup>2</sup> / <sub>8</sub> "	30 <sup>6</sup> / <sub>8</sub> "
WPG3636	12 <sup>5</sup> / <sub>8</sub> "	30 <sup>5</sup> / <sub>8</sub> "	13 <sup>13</sup> / <sub>16</sub> "	31 <sup>13</sup> / <sub>16</sub> "	13 <sup>7</sup> / <sub>8</sub> "	31 <sup>7</sup> / <sub>8</sub> "	12 <sup>1</sup> / <sub>4</sub> "	30 <sup>1</sup> / <sub>4</sub> "	12 <sup>1</sup> / <sub>4</sub> "	30 <sup>1</sup> / <sub>4</sub> "	11 <sup>7</sup> / <sub>8</sub> "	29 <sup>5</sup> / <sub>8</sub> "	12 <sup>2</sup> / <sub>8</sub> "	30 <sup>6</sup> / <sub>8</sub> "	12 <sup>2</sup> / <sub>8</sub> "	30 <sup>6</sup> / <sub>8</sub> "
WPG3636B	12 <sup>13</sup> / <sub>16</sub> "	30 <sup>5</sup> / <sub>8</sub> "	14"	31 <sup>13</sup> / <sub>16</sub> "	14 <sup>1</sup> / <sub>16</sub> "	31 <sup>7</sup> / <sub>8</sub> "	13 <sup>1</sup> / <sub>4</sub> "	30 <sup>1</sup> / <sub>4</sub> "	•	•	12 <sup>7</sup> / <sub>8</sub> "	29 <sup>5</sup> / <sub>8</sub> "	13 <sup>3</sup> / <sub>8</sub> "	30 <sup>5</sup> / <sub>8</sub> "	•	•
WPG2136	15 <sup>5</sup> / <sub>8</sub> "	30 <sup>5</sup> / <sub>8</sub> "	16 13/16"	31 <sup>13</sup> / <sub>16</sub> "	16 <sup>7</sup> / <sub>8</sub> "	31 <sup>7</sup> / <sub>8</sub> "	15 <sup>1</sup> / <sub>4</sub> "	30 <sup>1</sup> / <sub>4</sub> "	15 <sup>1</sup> / <sub>4</sub> "	30 <sup>1</sup> / <sub>4</sub> "	14 <sup>7</sup> / <sub>8</sub> "	29 <sup>5</sup> / <sub>8</sub> "	15 <sup>5</sup> / <sub>8</sub> "	30 <sup>5</sup> / <sub>8</sub> "	15 <sup>5</sup> / <sub>8</sub> "	30 <sup>5</sup> / <sub>8</sub> "
WPG2436	18 <sup>5</sup> / <sub>8</sub> "	30 <sup>5</sup> / <sub>8</sub> "	19 <sup>13</sup> / <sub>16</sub> "	31 <sup>13</sup> / <sub>16</sub> "	19 <sup>7</sup> / <sub>8</sub> "	31 <sup>7</sup> / <sub>8</sub> "	18 <sup>1</sup> / <sub>4</sub> "	30 <sup>1</sup> / <sub>4</sub> "	18 <sup>1</sup> / <sub>4</sub> "	30 <sup>1</sup> / <sub>4</sub> "	17 <sup>7</sup> / <sub>8</sub> "	29 <sup>5</sup> / <sub>8</sub> "	18 <sup>8</sup> / <sub>8</sub> "	30 <sup>6</sup> / <sub>8</sub> "	18 <sup>8</sup> / <sub>8</sub> "	30 <sup>6</sup> / <sub>8</sub> "
WPG1530	9 <sup>5</sup> / <sub>8</sub> "	24 <sup>5</sup> / <sub>8</sub> "	10 <sup>13</sup> / <sub>16</sub> "	25 <sup>13</sup> / <sub>16</sub> "	10 <sup>7</sup> / <sub>8</sub> "	25 <sup>7</sup> / <sub>8</sub> "	9 <sup>7</sup> / <sub>8</sub> "	24 <sup>1</sup> / <sub>4</sub> "	9 <sup>7</sup> / <sub>8</sub> "	24 <sup>1</sup> / <sub>4</sub> "	8 <sup>7</sup> / <sub>8</sub> "	23 <sup>5</sup> / <sub>8</sub> "	9 <sup>5</sup> / <sub>8</sub> "	24 <sup>5</sup> / <sub>8</sub> "	9 <sup>5</sup> / <sub>8</sub> "	24 <sup>5</sup> / <sub>8</sub> "
WPG3030	9 <sup>5</sup> / <sub>8</sub> "	24 <sup>5</sup> / <sub>8</sub> "	10 <sup>13</sup> / <sub>16</sub> "	25 <sup>13</sup> / <sub>16</sub> "	10 <sup>7</sup> / <sub>8</sub> "	25 <sup>7</sup> / <sub>8</sub> "	9 <sup>7</sup> / <sub>8</sub> "	24 <sup>1</sup> / <sub>4</sub> "	9 <sup>7</sup> / <sub>8</sub> "	24 <sup>1</sup> / <sub>4</sub> "	8 <sup>7</sup> / <sub>8</sub> "	23 <sup>5</sup> / <sub>8</sub> "	9 <sup>5</sup> / <sub>8</sub> "	24 <sup>5</sup> / <sub>8</sub> "	9 <sup>5</sup> / <sub>8</sub> "	24 <sup>5</sup> / <sub>8</sub> "
WPG3030B	9 <sup>13</sup> / <sub>16</sub> "	24 <sup>5</sup> / <sub>8</sub> "	11"	25 <sup>13</sup> / <sub>16</sub> "	11 <sup>1</sup> / <sub>16</sub> "	25 <sup>7</sup> / <sub>8</sub> "	10 <sup>1</sup> / <sub>4</sub> "	24 <sup>1</sup> / <sub>4</sub> "	•	•	9 <sup>7</sup> / <sub>8</sub> "	23 <sup>5</sup> / <sub>8</sub> "	10 <sup>5</sup> / <sub>8</sub> "	24 <sup>5</sup> / <sub>8</sub> "	•	•
WPG1830	12 <sup>5</sup> / <sub>8</sub> "	24 <sup>5</sup> / <sub>8</sub> "	13 <sup>13</sup> / <sub>16</sub> "	25 <sup>13</sup> / <sub>16</sub> "	13 <sup>7</sup> / <sub>8</sub> "	25 <sup>7</sup> / <sub>8</sub> "	12 <sup>1</sup> / <sub>4</sub> "	24 <sup>1</sup> / <sub>4</sub> "	12 <sup>1</sup> / <sub>4</sub> "	24 <sup>1</sup> / <sub>4</sub> "	11 <sup>7</sup> / <sub>8</sub> "	23 <sup>5</sup> / <sub>8</sub> "	12 <sup>2</sup> / <sub>8</sub> "	24 <sup>6</sup> / <sub>8</sub> "	12 <sup>2</sup> / <sub>8</sub> "	24 <sup>6</sup> / <sub>8</sub> "
WPG3630	12 <sup>5</sup> / <sub>8</sub> "	24 <sup>5</sup> / <sub>8</sub> "	13 <sup>13</sup> / <sub>16</sub> "	25 <sup>13</sup> / <sub>16</sub> "	13 <sup>7</sup> / <sub>8</sub> "	25 <sup>7</sup> / <sub>8</sub> "	12 <sup>1</sup> / <sub>4</sub> "	24 <sup>1</sup> / <sub>4</sub> "	12 <sup>1</sup> / <sub>4</sub> "	24 <sup>1</sup> / <sub>4</sub> "	11 <sup>7</sup> / <sub>8</sub> "	23 <sup>5</sup> / <sub>8</sub> "	12 <sup>2</sup> / <sub>8</sub> "	24 <sup>6</sup> / <sub>8</sub> "	12 <sup>2</sup> / <sub>8</sub> "	24 <sup>6</sup> / <sub>8</sub> "
WPG3630B	12 <sup>13</sup> / <sub>16</sub> "	24 <sup>5</sup> / <sub>8</sub> "	14"	25 <sup>13</sup> / <sub>16</sub> "	14 <sup>1</sup> / <sub>16</sub> "	25 <sup>7</sup> / <sub>8</sub> "	13 <sup>1</sup> / <sub>4</sub> "	24 <sup>1</sup> / <sub>4</sub> "	•	•	12 <sup>7</sup> / <sub>8</sub> "	23 <sup>5</sup> / <sub>8</sub> "	13 <sup>3</sup> / <sub>8</sub> "	24 <sup>5</sup> / <sub>8</sub> "	•	•
WPG2130	15 <sup>5</sup> / <sub>8</sub> "	24 <sup>5</sup> / <sub>8</sub> "	16 13/16"	25 <sup>13</sup> / <sub>16</sub> "	16 <sup>7</sup> / <sub>8</sub> "	25 <sup>7</sup> / <sub>8</sub> "	15 <sup>1</sup> / <sub>4</sub> "	24 <sup>1</sup> / <sub>4</sub> "	15 <sup>1</sup> / <sub>4</sub> "	24 <sup>1</sup> / <sub>4</sub> "	14 <sup>7</sup> / <sub>8</sub> "	23 <sup>5</sup> / <sub>8</sub> "	15 <sup>5</sup> / <sub>8</sub> "	24 <sup>5</sup> / <sub>8</sub> "	15 <sup>5</sup> / <sub>8</sub> "	24 <sup>5</sup> / <sub>8</sub> "
WPG2430	18 <sup>5</sup> / <sub>8</sub> "	24 <sup>5</sup> / <sub>8</sub> "	19 <sup>13</sup> / <sub>16</sub> "	25 <sup>13</sup> / <sub>16</sub> "	19 <sup>7</sup> / <sub>8</sub> "	25 <sup>7</sup> / <sub>8</sub> "	18 <sup>1</sup> / <sub>4</sub> "	24 <sup>1</sup> / <sub>4</sub> "	18 <sup>1</sup> / <sub>4</sub> "	24 <sup>1</sup> / <sub>4</sub> "	17 <sup>7</sup> / <sub>8</sub> "	23 <sup>5</sup> / <sub>8</sub> "	18 <sup>8</sup> / <sub>8</sub> "	24 <sup>6</sup> / <sub>8</sub> "	18 <sup>8</sup> / <sub>8</sub> "	24 <sup>6</sup> / <sub>8</sub> "
WPG3024	9 <sup>5</sup> / <sub>8</sub> "	18 <sup>5</sup> / <sub>8</sub> "	10 <sup>13</sup> / <sub>16</sub> "	19 <sup>13</sup> / <sub>16</sub> "	10 <sup>7</sup> / <sub>8</sub> "	19 <sup>7</sup> / <sub>8</sub> "	9 <sup>7</sup> / <sub>8</sub> "	18 <sup>1</sup> / <sub>4</sub> "	9 <sup>7</sup> / <sub>8</sub> "	18 <sup>1</sup> / <sub>4</sub> "	8 <sup>7</sup> / <sub>8</sub> "	17 <sup>5</sup> / <sub>8</sub> "	9 <sup>5</sup> / <sub>8</sub> "	18 <sup>5</sup> / <sub>8</sub> "	9 <sup>5</sup> / <sub>8</sub> "	18 <sup>5</sup> / <sub>8</sub> "
WPG3024B	9 <sup>13</sup> / <sub>16</sub> "	18 <sup>5</sup> / <sub>8</sub> "	11"	19 <sup>13</sup> / <sub>16</sub> "	11 <sup>1</sup> / <sub>16</sub> "	19 <sup>7</sup> / <sub>8</sub> "	10 <sup>1</sup> / <sub>4</sub> "	18 <sup>1</sup> / <sub>4</sub> "	•	•	9 <sup>7</sup> / <sub>8</sub> "	17 <sup>5</sup> / <sub>8</sub> "	10 <sup>5</sup> / <sub>8</sub> "	18 <sup>5</sup> / <sub>8</sub> "	•	•
PWPG3024	9 <sup>5</sup> / <sub>8</sub> "	18 <sup>5</sup> / <sub>8</sub> "	10 <sup>13</sup> / <sub>16</sub> "	19 <sup>13</sup> / <sub>16</sub> "	10 <sup>7</sup> / <sub>8</sub> "	19 <sup>7</sup> / <sub>8</sub> "	9 <sup>7</sup> / <sub>8</sub> "	18 <sup>1</sup> / <sub>4</sub> "	9 <sup>7</sup> / <sub>8</sub> "	18 <sup>1</sup> / <sub>4</sub> "	8 <sup>7</sup> / <sub>8</sub> "	17 <sup>5</sup> / <sub>8</sub> "	9 <sup>5</sup> / <sub>8</sub> "	18 <sup>5</sup> / <sub>8</sub> "	9 <sup>5</sup> / <sub>8</sub> "	18 <sup>5</sup> / <sub>8</sub> "
PWPG3024B	9 <sup>13</sup> / <sub>16</sub> "	18 <sup>5</sup> / <sub>8</sub> "	11"	19 <sup>13</sup> / <sub>16</sub> "	11 <sup>1</sup> / <sub>16</sub> "	19 <sup>7</sup> / <sub>8</sub> "	10 <sup>1</sup> / <sub>4</sub> "	18 <sup>1</sup> / <sub>4</sub> "	•	•	9 <sup>7</sup> / <sub>8</sub> "	17 <sup>5</sup> / <sub>8</sub> "	10 <sup>5</sup> / <sub>8</sub> "	18 <sup>5</sup> / <sub>8</sub> "	•	•
WPG3624	12 <sup>5</sup> / <sub>8</sub> "	18 <sup>5</sup> / <sub>8</sub> "	13 <sup>13</sup> / <sub>16</sub> "	19 <sup>13</sup> / <sub>16</sub> "	13 <sup>7</sup> / <sub>8</sub> "	19 <sup>7</sup> / <sub>8</sub> "	12 <sup>1</sup> / <sub>4</sub> "	18 <sup>1</sup> / <sub>4</sub> "	12 <sup>1</sup> / <sub>4</sub> "	18 <sup>1</sup> / <sub>4</sub> "	11 <sup>7</sup> / <sub>8</sub> "	17 <sup>5</sup> / <sub>8</sub> "	12 <sup>2</sup> / <sub>8</sub> "	18 <sup>6</sup> / <sub>8</sub> "	12 <sup>2</sup> / <sub>8</sub> "	18 <sup>6</sup> / <sub>8</sub> "
WPG3624B	12 <sup>13</sup> / <sub>16</sub> "	18 <sup>5</sup> / <sub>8</sub> "	14"	19 <sup>13</sup> / <sub>16</sub> "	14 <sup>1</sup> / <sub>16</sub> "	19 <sup>7</sup> / <sub>8</sub> "	13 <sup>1</sup> / <sub>4</sub> "	18 <sup>1</sup> / <sub>4</sub> "	•	•	12 <sup>7</sup> / <sub>8</sub> "	17 <sup>5</sup> / <sub>8</sub> "	13 <sup>3</sup> / <sub>8</sub> "	18 <sup>5</sup> / <sub>8</sub> "	•	•
PWPG3624	12 <sup>5</sup> / <sub>8</sub> "	18 <sup>5</sup> / <sub>8</sub> "	13 <sup>13</sup> / <sub>16</sub> "	19 <sup>13</sup> / <sub>16</sub> "	13 <sup>7</sup> / <sub>8</sub> "	19 <sup>7</sup> / <sub>8</sub> "	12 <sup>1</sup> / <sub>4</sub> "	18 <sup>1</sup> / <sub>4</sub> "	12 <sup>1</sup> / <sub>4</sub> "	18 <sup>1</sup> / <sub>4</sub> "	11 <sup>7</sup> / <sub>8</sub> "	17 <sup>5</sup> / <sub>8</sub> "	12 <sup>2</sup> / <sub>8</sub> "	18 <sup>6</sup> / <sub>8</sub> "	12 <sup>2</sup> / <sub>8</sub> "	18 <sup>6</sup> / <sub>8</sub> "
PWPG3624B	12 <sup>13</sup> / <sub>16</sub> "	18 <sup>5</sup> / <sub>8</sub> "	14"	19 <sup>13</sup> / <sub>16</sub> "	14 <sup>1</sup> / <sub>16</sub> "	19 <sup>7</sup> / <sub>8</sub> "	13 <sup>1</sup> / <sub>4</sub> "	18 <sup>1</sup> / <sub>4</sub> "	•	•	12 <sup>7</sup> / <sub>8</sub> "	17 <sup>5</sup> / <sub>8</sub> "	13 <sup>3</sup> / <sub>8</sub> "	18 <sup>5</sup> / <sub>8</sub> "	•	•
WPG3021	9 <sup>5</sup> / <sub>8</sub> "	15 <sup>5</sup> / <sub>8</sub> "	10 <sup>13</sup> / <sub>16</sub> "	16 <sup>13</sup> / <sub>16</sub> "	10 <sup>7</sup> / <sub>8</sub> "	16 <sup>7</sup> / <sub>8</sub> "	9 <sup>1</sup> / <sub>4</sub> "	15 <sup>1</sup> / <sub>4</sub> "	9 <sup>1</sup> / <sub>4</sub> "	15 <sup>1</sup> / <sub>4</sub> "	8 <sup>7</sup> / <sub>8</sub> "	14 <sup>5</sup> / <sub>8</sub> "	9 <sup>5</sup> / <sub>8</sub> "	15 <sup>5</sup> / <sub>8</sub> "	9 <sup>5</sup> / <sub>8</sub> "	15 <sup>5</sup> / <sub>8</sub> "
WPG3021B	9 <sup>13</sup> / <sub>16</sub> "	15 <sup>5</sup> / <sub>8</sub> "	11"	16 <sup>13</sup> / <sub>16</sub> "	11 <sup>1</sup> / <sub>16</sub> "	16 <sup>7</sup> / <sub>8</sub> "	10 <sup>1</sup> / <sub>4</sub> "	15 <sup>1</sup> / <sub>4</sub> "	•	•	9 <sup>7</sup> / <sub>8</sub> "	14 <sup>5</sup> / <sub>8</sub> "	10 <sup>5</sup> / <sub>8</sub> "	15 <sup>5</sup> / <sub>8</sub> "	•	•
WPG3621	12 <sup>5</sup> / <sub>8</sub> "	15 <sup>5</sup> / <sub>8</sub> "	13 <sup>13</sup> / <sub>16</sub> "	16 <sup>13</sup> / <sub>16</sub> "	13 <sup>7</sup> / <sub>8</sub> "	16 <sup>7</sup> / <sub>8</sub> "	12 <sup>1</sup> / <sub>4</sub> "	15 <sup>1</sup> / <sub>4</sub> "	12 <sup>1</sup> / <sub>4</sub> "	15 <sup>1</sup> / <sub>4</sub> "	11 <sup>7</sup> / <sub>8</sub> "	14 <sup>5</sup> / <sub>8</sub> "	12 <sup>2</sup> / <sub>8</sub> "	15 <sup>6</sup> / <sub>8</sub> "	12 <sup>2</sup> / <sub>8</sub> "	15 <sup>6</sup> / <sub>8</sub> "
WPG3621B	12 <sup>13</sup> / <sub>16</sub> "	15 <sup>5</sup> / <sub>8</sub> "	14"	16 <sup>13</sup> / <sub>16</sub> "	14 <sup>1</sup> / <sub>16</sub> "	16 <sup>7</sup> / <sub>8</sub> "	13 <sup>1</sup> /<									













## NOTES ✓

- ▶ Screws included with hardware.
- ▶ Order under style #010.
- ▶ Hardware is recommended for use on all full overlay and miter door styles (except Avalon and Radford). All other door styles have a reverse bevel and hardware is not required.

\*Hardware does not fit certain Briarcliff II, Durham, Nantucket, Overton, and Wentworth drawers because of small width of recessed center drawer panel.



## Hardware Chart

	PRODUCT CODE	Item Description	Finish/Color	Drill Center
	H112	Knob 1¼"	Black Chrome	N/A
	H167	Knob 1¼"	Polished Brass Plated	N/A
	H300	Knob 1¼"	Patina Black	N/A
	H302 *	Pull 4¾"	Patina Black	4"
	H303	Knob 1¼"	Patina Black	N/A
	H304 *	Pull 4¾"	Patina Rouge	4"
	H305	Knob 1¼"	Patina Rouge	N/A
	H307	Knob 1¼"	Patina Rouge	N/A
	H308 *	Pull 5½"	German Bronze	128mm
	H310	Knob 1¼"	German Bronze	N/A
	H311 *	Pull 5½"	Antique Pewter	128mm
	H312 *	Cup Pull 2½"	Antique Pewter	64mm
	H313	Knob 1¼"	Antique Pewter	N/A
	H314 *	Pull 4⅞"	Brushed Satin Nickel	96mm
	H315 *	Pull 5⅓"	Brushed Satin Nickel	128mm















# Hardware Chart

**NOTES** ✓

- ▶ Screws included with hardware.
- ▶ Order under style #010.
- ▶ Hardware is recommended for use on all full overlay and miter door styles (except Avalon and Radford). All other door styles have a reverse bevel and hardware is not required.

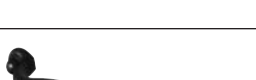
\*Hardware does not fit certain Briarcliff II, Durham, Nantucket, Overton, and Wentworth drawers because of small width of recessed center drawer panel.



	PRODUCT CODE	Item Description	Finish/Color	Drill Center
	H316	Knob 1 1/4"	Brushed Satin Nickel	N/A
	H317	Knob 1 1/4"	Polished Chrome	N/A
	H318 *	Pull 5 3/8"	Flat Black	128mm
	H319	Large Flower Twist Knob 1 1/4"	Pewter	N/A
	H320 *	Twist Wire Drop Handle 5 19/32"	Pewter	5"
	H322	Knob 1 1/4"	Nouveau White	N/A
	H323	Knob 1 1/4"	Flat Black	N/A
	H332 *	Pull 5"	Brushed Satin Nickel	96mm
	H333 *	Pull 4 3/8"	Oil Rubbed Bronze	4"
	H334	Knob 1 1/4"	Oil Rubbed Bronze	N/A
	H335 *	Birdcage Pull 4 1/3"	Pewter	4"
	H336 *	Pull 5 2/3"	Venetian Bronze	128mm
	H337 *	Birdcage Pull 4 1/3"	Venetian Bronze	4"
	H338 *	Pull 5"	Black Chrome	96mm
	H339	Birdcage Knob 1 1/4"	Venetian Bronze	N/A











NOTES ✓

- ▶ Screws included with hardware.
- ▶ Order under style #010.
- ▶ Hardware is recommended for use on all full overlay and miter door styles (except Avalon and Radford). All other door styles have a reverse bevel and hardware is not required.

\*Hardware does not fit certain Briarcliff II, Durham, Nantucket, Overton, and Wentworth drawers because of small width of recessed center drawer panel.



Hardware Chart

	PRODUCT CODE	Item Description	Finish/Color	Drill Center
	H340	Knob 1 1/4"	Venetian Bronze	N/A
	H341	Maple Knob 1 1/4"	Standard Finishes Order under Maple finish style numbers: Autumn 183, Café 167, Fawn 197, Natural 182, Rouge 180, Saddle 170, Sarsaparilla 193, or Umber 157	N/A
	H342	Oak Knob 1 1/4"	Standard Finishes Order under Oak finish style numbers: Natural 188, Saddle 171, Sarsaparilla 187, Spice 185, Umber 158, or Wheat 186	N/A
	H343 *	Pull 6 19/64"	Brushed Satin Nickel	128mm
	H344	Pull 4 1/2"	Brushed Satin Nickel	96mm
	H345	Knob 1 1/4"	Brushed Satin Nickel	N/A
	H346	Pull 4 1/8"	Brushed Satin Nickel	96mm
	H347	Pull 4 1/8"	Brushed Satin Nickel	3"
	H348	Knob 1 11/16"	Brushed Satin Nickel	N/A
	H349	Pull 7"	Brushed Satin Nickel	96mm
	H350	Pull 8 1/5"	Brushed Satin Nickel	128mm

## Warped Door Policy

Aristokraft cabinetry is constructed to strict specifications, including the moisture content present in wood. When the moisture content is maintained at a constant level, Aristokraft is able to minimize the amount of expansion and contraction associated with natural wood. When a great amount of expansion and contraction occur, the result can be a warped door. By strictly controlling the amount of humidity present during manufacturing, Aristokraft is helping to ensure you receive a quality product.

Because wood is a natural product, each piece of wood exhibits its own unique color and grain variations. These differences give wood its genuine beauty. The wood's natural properties also determine how each individual piece will react to changing weather conditions. Therefore, eliminating warped doors is virtually impossible.

If you feel that you have a warped door, Aristokraft requires that you perform initial testing to determine the extent of the problem.

1. Remove the door from the cabinet and remove all decorative surface knobs or pulls and hinges.
2. Place the door on a completely flat surface, as determined by using a level, and alternately press on the opposite corners to observe if the door "rocks" or pulls away from the flat surface.
3. If you observe a gap between the door and flat surface, measure the distance to determine the amount of warpage.
  - A door must be warped at least 1/4" before it can be considered for replacement. When ordering a replacement by using Aristokraft Part Replacement Order Form, be sure to fill in the reason for proper replacement code as "W".
  - If the door is warped less than 1/4", we recommend you allow a complete heating and cooling cycle (summer to winter) to allow the door to reach moisture equilibrium. Adding magnetic catches or roller catches will often correct minor problems.
4. If the door does not pull away from the flat surface, it is not warped. Most likely, there is a problem with the cabinet installation. When cabinets are not properly installed in a level or plumb position, they will become racked and will cause the door to appear warped. To check for a racked cabinet, place a level on one end rail. The bubble in the level will appear centered if the cabinet was properly installed in a level position. Now place the level on the other end rail. Again, if the bubble appears centered the cabinet is properly installed in a level position. Any variations in the location of the bubble will indicate the cabinet was not properly installed. (A plumb bob will reveal the same information.)

Another proper installation check is to place the level in the top, and then bottom of the installed cabinets face frame. Identify the bubble's position in both, top and bottom, locations of the face frame. The bubble's position will indicate if the cabinet was not properly installed.

## Cabinet Care Suggestions

**Cleaning Tip:** Never use a dishcloth to clean or dry cabinet exteriors or interiors. Remnants of detergent or grease may be contained within the dishcloth.

**Interiors:** Aristokraft cabinet interiors are surfaced with Aristex®, a quality laminate material that resists scuffs, marks, and most common household spills.

1. To clean the interior surface, simply wipe with a damp cloth or sponge, then dry.
2. To remove food residue or grease, use the suds from any common dishwashing liquid and a damp cloth to wipe clean. Dry thoroughly.

**CAUTION:** If a spill occurs, it is important to clean up the spill and dry the surface immediately. A spill left unattended will soak through the Aristex™ and cause damage.

**Exteriors — Wood Finish:** Aristokraft wood exteriors are manufactured with a quality finish that protects the wood and brings out its full beauty. To maintain your cabinets' appearance, Aristokraft recommends cleaning them at least once a month.

1. Simply wipe the surface of your cabinets with a clean damp cloth, then dry.
2. To remove general soil or grease, use the suds from any common dishwashing liquid and a damp cloth to wipe clean. Dry thoroughly.
3. Excess moisture can damage any cabinet finish; areas near the sink, range, dishwasher, oven and baseboards are the most susceptible. Keep these surfaces dry.
4. Because Aristokraft uses a quality varnish on the finish, waxing your cabinets is not necessary. If waxing is preferred, use any furniture polish or lemon oil recommended for fine furniture. Be sure to completely wipe off the excess wax to avoid build-up.

**CAUTION:** Avoid using cleaners that contain bleach, ammonia or state on the label they have any type of abrasives. These cleaners can cause damage to your cabinet finish.

**Exteriors — PureStyle™/Thermofoil:** Some Aristokraft styles use doors and drawer fronts with a laminate or thermofoil finish. To clean this type of finish, Aristokraft recommends the same procedure described for wood exteriors.

## Discontinued Product Policy

- A minimum of 60 days notice will be given to customers announcing the discontinuation of a product.
- Product will no longer be available to order after the discontinuation date. Only warranty orders will be considered. With warranty orders, Aristokraft will have the option to repair or replace a customer's defective product with the same discontinued product they originally purchased or with a current product that is similar in appearance.

## Freight Policy

- If an entire order is no charge, Aristokraft will pay for standard ground freight.
- If an order contains a chargeable item, the cost of freight will be charged to the customer's invoice.
- If a customer requests an upgrade to a parcel shipment method, the customer will be charged the entire freight charge.

## Returned Goods Policy

- All cabinets are manufactured according to the individual order and cannot be changed, cancelled, or returned once order has been scheduled.

## Transportation Claims

- Please inspect merchandise at time of signing freight bill, and have transportation company note any damage incurred in transit.

## Disclosure

- Prices and specifications are subject to change without notice.





## Aristokraft 5 Year and Limited Lifetime Warranty

**Five Year Limited Warranty on Cabinets.** Aristokraft warrants to original consumer purchasers for a period of five years from the original date of purchase that all other components of Aristokraft cabinetry shall be free from defects in material and workmanship under normal use.

**Lifetime Limited Warranty on Drawer Guides and Hinges.** Aristokraft warrants to original consumer purchasers for as long as they own their homes that the drawer box, drawer guides and hinges used in the manufacture of Aristokraft cabinetry products shall be free from defects in material and workmanship under normal use.

These warranties are only applicable to products used in residential applications within the United States and is not transferable to subsequent owners.

Should defects in material or workmanship exist during the applicable warranty period in any Aristokraft product, Aristokraft will elect at its discretion to either repair or replace the defective material or component free of charge. This warranty covers only parts and materials of the products supplied by Aristokraft. Not covered under this warranty are counter tops, appliances, plumbing fixtures, etc. or the costs, including labor, to remove and reinstall materials and related components such as fittings, appliances, etc.

This warranty shall become void if the cabinets are in any way modified, improperly installed or damaged prior to or during the installation. This also disclaims products utilized in any application other than the standard. Furthermore, this warranty will not apply to cabinets damaged by misuse, neglect, abuse, acts of God, exposure to moisture, exposure to extreme temperatures or the effects of normal wear and tear.

Natural woods may vary in color, characteristics and exhibit subtle changes as they age. Sunlight, smoke, household cleaners and other environmental conditions may also affect the color match over time. These variations are considered to be the nature of the material in relation to their environmental exposure and are not covered under this warranty.

Aristokraft reserves the right to alter design, specifications and material without obligation to make similar changes to products previously manufactured.

The repair(s) or replacement(s) are contingent upon the current product offerings of styles and construction options within the Aristokraft product at the time of the warranty claim. If a warranty claim is filed after an Aristokraft product becomes obsolete, Aristokraft reserves the right to honor the warranty in one of the following fashions:

- 1) To replace the affected component with a new component of the same style.
- 2) To replace the affected component and any other component(s) in the residential application to achieve a uniform appearance with a similar and comparable product style of the originally purchased style.

If components are replaced, Aristokraft cannot guarantee that the finish of these replacements will exactly match the finish and appearance of the components in the residential application. This is due to the changes that occur during the woods' natural aging process, affecting its color and grain.

**THIS WARRANTY IS THE EXCLUSIVE WARRANTY OF ARISTOKRAFT AND IS IN LIEU OF AND ARISTOKRAFT DISCLAIMS ALL OTHER WARRANTIES, EXPRESSED OR IMPLIED, INCLUDING THE IMPLIED WARRANTIES OF MERCHANTABILITY AND FITNESS FOR A PARTICULAR PURPOSE.**

This warranty gives you specific legal rights and you may have other rights, which vary from state to state. Some states do not allow the exclusion or limitation of incidental or consequential damages, so the above limitations or exclusions may not apply to you.

To obtain replacement(s) under Aristokraft's Five Year and Lifetime Limited warranties, first contact your authorized Aristokraft Cabinetry dealer or distributor, who will arrange for inspection of the cabinet. A dated sales receipt as proof of purchase is required to obtain benefits from this warranty.

If you have difficulty obtaining assistance, please write to:

Aristokraft Cabinetry  
One MasterBrand Cabinets Drive  
P.O. Box 420  
Jasper, IN 47547-0420  
Phone: (812) 482-2527 or Fax: (812) 634-2838

Aristokraft Cabinetry is a subsidiary of MasterBrand Cabinets, Inc.

**U.P.S. and Parcel Post address:**

Aristokraft Cabinetry  
One MasterBrand Cabinets Drive  
Jasper, Indiana 47547-0420  
Phone: (812) 482-2527  
Fax: (812) 634-2838

**Aristokraft**<sup>®</sup>  
CABINETY



Aristokraft<sup>®</sup> Cabinetry is a certified brand in the Kitchen Cabinet Manufacturers Association (KCMA) Environmental Stewardship Program. The program recognizes companies that demonstrate an ongoing commitment to environmental practices and sustainability.

With Aristokraft, you have a reliable partner committed to delivering solutions and building value. Home after home. Time after time. With Aristokraft, confidence is built in.

Product photography and illustration have been reproduced as accurately as printing technologies permit. To ensure highest satisfaction, we strongly recommend you view an actual sample for best color wood grain and finish representation.

[www.aristokraft.com](http://www.aristokraft.com)

MasterBrand Cabinets, Inc.  
Printed in USA