

American Standard

SPLIT SYSTEM COOLING UNITS

7 1/2, 10, 12 1/2, 15, 20 TONS



**Air Handlers; 5 through 20 Ton
Cooling Coils; 10 Ton**

Introduction

Split System Heat Pump Units . . . Designed With Your Needs In Mind.



The American Standard reputation for quality and reliability in air conditioning is apparent with the light commercial family of split systems. These American Standard systems are designed to meet your job requirements every time...and at a competitive price.

Couple American Standard's reputation for quality and reliability with outstanding efficiency, flexibility and installation ease and you have an unbeatable combination for years of worry-free service and operation.

Manufacturing Control

American Standard's exclusive control over the design and manufacturing of all major components is unique in the industry. This approach assures us total control over both the quality and reliability of these components.

©2004 American Standard Inc. All rights reserved.

And allows us to custom match components to deliver the best in split system performance.

Designing the Details

Careful attention was given to designing the details — from control wiring to the access panels. Light commercial units feature time-saving colored and numbered wiring and removable panels which allow complete access to all major components and controls. All outdoor units feature external high and low pressure switches for easy diagnosing and servicing of the unit. Service valves with gauge ports are provided on all units.

Standardized Cabinets

In addition, all cabinets have been standardized. When you are servicing an outdoor unit or an air handler, all components are in the same location from unit to unit.

Filters

The 5, 7½ and 10 ton air handlers are supplied with 1" throwaway filters as standard. The filter racks were designed to easily convert for installation of 2" filters. The 15 and 20 ton air handlers have 2" filters as standard.

UL Listed and ARI Certified

American Standard meets or exceeds all nationally recognized agency safety and design standards. Each condensing unit is UL designed, approved and labeled in accordance to UL Standards: UL 1995 for central cooling air conditioners, refrigeration and air conditioning condensing and compressor units. Each air handler is designed, approved and labeled in accordance to UL 465 and UL 1995 standard for heat pumps. Each unit is certified in accordance with ARI Standard 340/360 or 365.

Table of Contents

Introduction	2
Features and Benefits	4
Application Considerations	8
Selection Procedures	9
Model Number Description	10
General Data	11
Performance Data	14
Cool and Heat Performance	14
Fan Performance	30
Controls	43
Electrical Power	44
Dimensional Data	55
Mechanical Specifications	77

PRODUCT DATA

American Standard Inc.

Features and Benefits



Condensing Units Options

The light commercial split system product line includes condensing units in single, unloading and dual compressor options.

The 7½ and 10-ton single compressor models feature single refrigeration circuitry lowering job installation costs by requiring only one set of refrigerant lines. These units are ideal for the low cost, new construction jobs as well as renovation and replacement buildings.

Equally important, light commercial units offer a single refrigerant circuit/capacity unloading option in 10 and 15-ton condensing units. These unloading units feature dual manifolded scroll compressors. They offer an excellent opportunity for both new construction and replacement jobs with two stages of capacity modulation and a single refrigeration circuit.

In addition, light commercial units include a 10, 12½, 15 and 20-ton dual scroll compressor unit to give true stand-by protection; if one compressor fails, the second will automatically start-up. Also, the first compressor can be serviced without shutting down the unit since refrigerant circuits are independent.

Dual compressors are not just for protection, they also save energy costs.

Most buildings are designed for the peak load requirements yet the building usually operates at less than peak load. During light load conditions only one compressor functions to maintain the space comfort thus reducing the need for energy. For instance, the EER of the 10-ton unit at ARI conditions is 10.3 and at part load conditions it is 11.2.

American Standard split systems have been specified in thousands of applications and you'll find light commercial units will win you even more jobs with it's smaller, more manageable cabinet. This lighter, compact design will save time and money for rigging and installation. And the compactness will permit American Standard's unit to replace almost any unit — effortlessly.

Low Ambient Cooling Operation

Each heat pump unit can operate to 50° F as standard. An accessory Head Pressure Control gives you the capability to operate to 0° F. All condensing units offer these accessories:

- Head Pressure Control
- Coil Guard Kits
- Isolators both Rubber-in-Shear and Spring Type
- Anti-Short-Cycle Kit

- Time Delay Relay
- Black Epoxy Coated Coil

Air Handlers Offer More Flexibility

Flexibility is a key to meeting changing market requirements. Light commercial split systems offer not only heat pumps but also convertible air handlers. The air handlers can be installed either vertically in a mechanical room or horizontally above a ceiling. And it doesn't require any removal of panels to make either airflow application work. These air handlers have a double sloped condensate drain pan that allows for either airflow configuration. And the drain pan can easily be removed for cleaning. All the air handlers feature factory installed belt drive and ball bearing evaporator fans with adjustable sheaves for maximum airflow performance. In fact, the standard motor on the 10-ton air handler will deliver 4000 cfm at 1.4" ESP. Plus oversized motors are available for higher static applications.

Features and Benefits

Light commercial air handler versatility is further increased by a complete line of accessories designed to match and install smoothly:

- Discharge Plenum and Grille
- Return Grille
- Subbase
- Electric Heaters
- High Static Evaporator Motor
- Isolators both Rubber-in-Shear and Spring Type
- A Full Line of Thermostats
- Outdoor Thermostat

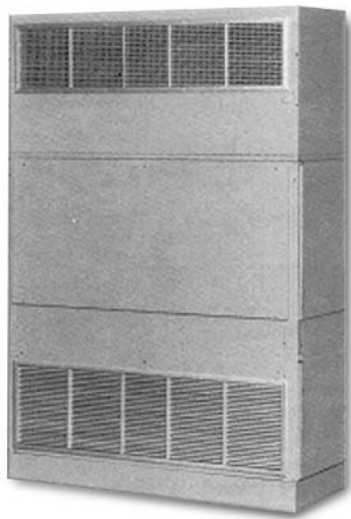

Light Commercial – A Complete Split System

Light commercial units deliver the flexibility to select a complete system that meets your particular job requirements. Air handlers are designed, tested, and rated with outdoor units to let you select the proper match between capacity and load. Heat pumps can also be matched with American Standard built-up air handlers. Also, these matched systems can be quickly engineered for specific applications using American Standard's computerized selection and load programs.

Light Commercial Systems Lower Installation Costs

Your installation costs are reduced with light commercial units. Both outdoor units and air handlers are factory packaged and assembled so jobsite installation is quick and easy. You get a complete unit with all the components, controls and the internal wiring factory ready for a smooth jobsite start-up.

Unlike some competitive models the following components are factory-installed in American Standard air handlers:

- Single Point Power Entry
- Blower wheel and housing
- Evaporator motor with sheaves and pulleys
- Low Voltage Terminal Board
- Transformer
- Contactor
- Fan relay
- DX Coil with complete refrigeration circuitry
- Expansion Valve and Check Valves

There's no need to install components and put together the air handler on the job. This provides you with less labor cost and fewer chances for installation errors which cause callbacks. All this means saving you money both in replacement and new construction applications.



PRODUCT DATA

American Standard Inc.

Features and Benefits

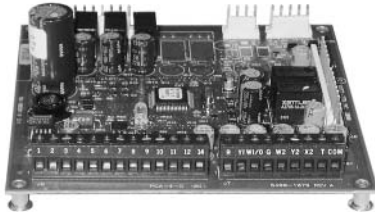

Micro Controls

Several years ago, American Standard was the first to introduce microprocessor controls into the Light Commercial Market. That design, along with immeasurable experience, has provided the technology for American Standard's second-generation ReliaTel™ microprocessor controls in light commercial split unit systems — the first in the industry.

ReliaTel™ Micro:

- Provides unit control for heating and cooling, by utilizing input from sensors that measure indoor temperature.
- Improves quality and reliability through the use of time-tested microprocessor controls and logic.
- Prevents the unit from short cycling, considerably improving compressor life.
- Ensures that the compressor will run for a specific amount of time, which allows oil to return for better lubrication, enhancing the reliability of the compressor.
- Reduces the number of components required to operate the unit, thereby reducing possibilities for component failure.
- Eliminates the need for field-installed components with its built-in anti-short-cycle timer, time delay relay and minimum "on" time controls. These controls are factory tested to assure proper operation.

- Requires no special tools to run the unit through its paces during testing. Simply place a jumper between Test 1 and Test 2 terminals on the Low Voltage Terminal Board and the unit will walk through its operational steps. The unit automatically returns control to the zone sensor after stepping through the test mode a single time, even if the jumper is left on the unit.
- As long as the unit has power and the LED is lit, the Micro is operational. The light indicates that the Micro is functioning properly.
- Features expanded diagnostic capabilities when used with American Standard's Integrated Comfort™ Systems.
- As an energy benefit, softens electrical "spikes" by staging on fans, compressors and heaters.
- The Intelligent Fallback or Adaptive Control is a benefit to the building occupant. If a component goes astray, the unit will continue to operate at predetermined temperature set points.
- Intelligent Anticipation is a standard feature of the Micro. Functioning constantly, the Micro and zone sensors work together in harmony, to provide tight comfort control.

Electromechanical Controls

For the simpler job that does not require a building automation system, or expanded diagnostics capabilities, the unit offers electromechanical controls. This 24-volt control includes the control transformer, contactor pressure lugs for power wiring.

Features and Benefits

Quality and Reliability Testing

- All units were rigorously rain tested at the factory to ensure water integrity.
- Actual shipping tests were performed to determine packaging requirements. Units were test shipped around the country to determine the best packaging.
- Factory shake and drop tests were used as part of the package design process to help assure that the unit arrives at the job site in top condition.
- Rigging tests include lifting a unit into the air and letting it drop one foot, assuring that the lifting lugs and rails hold up under stress.
- We perform a 100% coil leak test at the factory. The evaporator and condenser coils are leak tested at 375 psig and pressure tested to 420 psig.
- All parts are inspected at the point of final assembly. Sub-standard parts are identified and rejected immediately.
- Every unit receives a 100% unit run test before leaving the production line to make sure it lives up to rigorous American Standard requirements.

We test designs at our factory not on our customers!

PRODUCT DATA

American Standard Inc.

Application Considerations

Application of this product should be within the catalogued airflow and performance considerations.

Clearance Requirements

The recommended clearances identified with unit dimensions should be maintained to assure adequate serviceability, maximum capacity and peak operating efficiency. Actual clearances which appear inadequate should be reviewed with the local American Standard Representative.

180° Blower Rotation

The 5, 7½, and 10 ton air handler blower section can be rotated 180° to change the discharge pattern. This modification must be done in the field and requires an addition of kit. See unit installer's guide.

Low Ambient Cooling

As manufactured, these units can operate to 50° F in the cooling mode of operation. An accessory head pressure control will allow operation to 0° F outdoor ambient. When using these units with control systems such as bypass changeover Variable Air Volume, make sure you consider the requirement for a head pressure control to allow low ambient cooling.

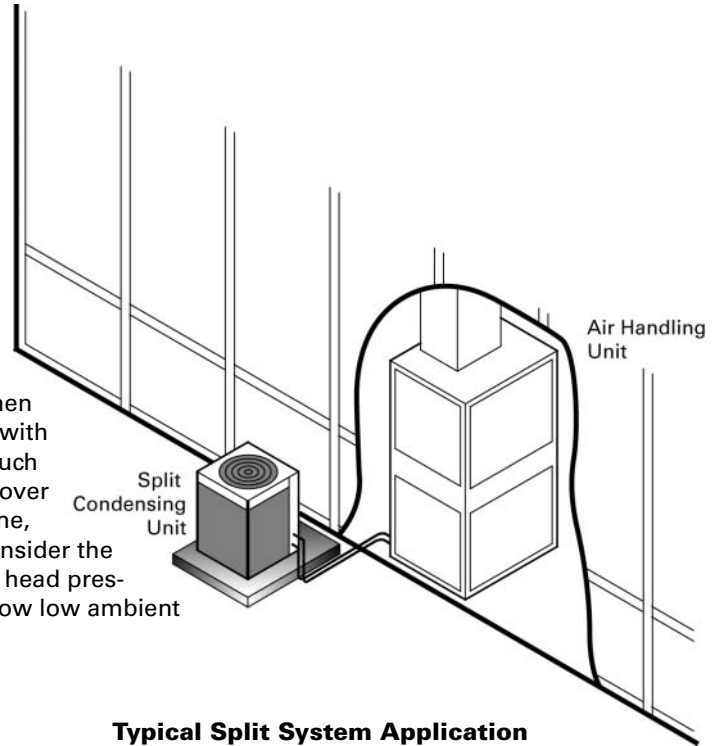

Typical Split System Application

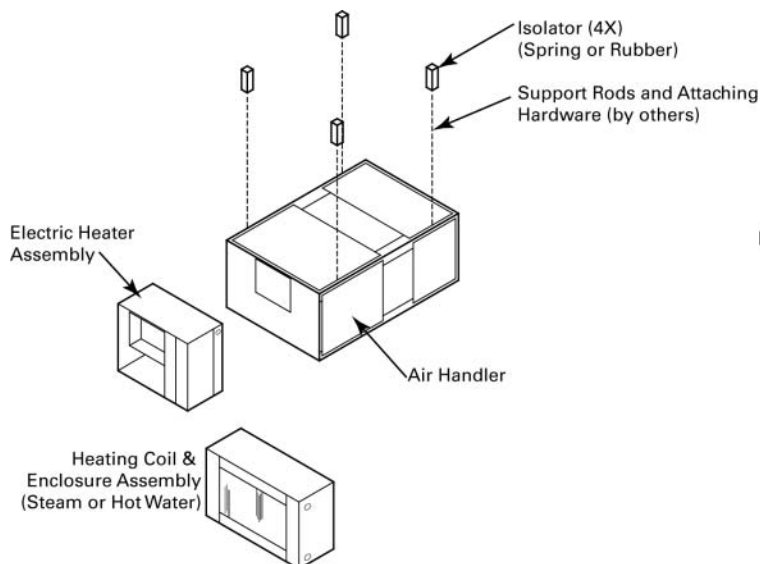

Typical Horizontal Air Handler Application

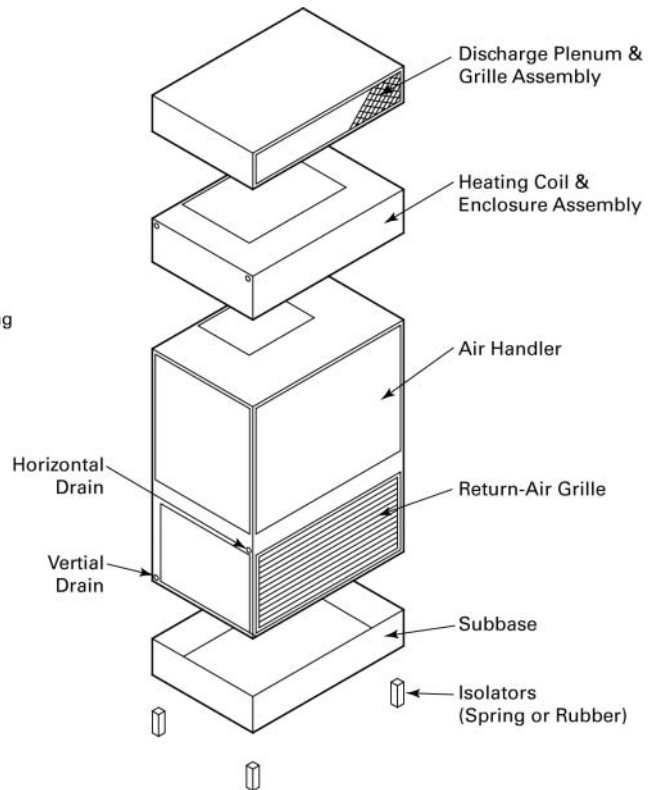

Typical Vertical Air Handler Application

Selection Procedure

Cooling Capacity

Step 1 — Calculate the building's total and sensible cooling loads at design conditions. Use the Trane calculation form or any other standard accepted method.

Step 2 — Size the equipment using Table PD-1. Match the cooling loads at design conditions.

Example: The following are the building cooling requirements:

- a. Electrical Characteristics: 460/60/3
- b. Summer Design Conditions:
Entering Evaporator Coil:
80° F DB/67° F WB
Outdoor Ambient: 95° F
- c. Total Cooling Load: 88MBh
- d. Sensible Cooling Load: 64 MBh
- e. Airflow: 3000 cfm
External Static Pressure:
0.77 inches of water gauge

Table PD-1 shows that TTA090A4 with TWE090A has a gross cooling capacity of 92.0 MBh and 65.5 MBh sensible capacity at 95° F DB ambient and 3000 cfm with 80° F DB/67° F WB air entering the evaporator.

To find the net cooling capacities, fan motor heat must be subtracted. Determine the total unit static pressure:

- External Static: 0.77 in.
- Standard Filter: 0.10 in.
- Supplementary Electric Heat: 0.23 in.
- Total Static Pressure 1.10 in.

Note: The Evaporator Fan Performance Table has included the effect of a 1 in. filter already. Therefore, the actual Total Static Pressure is $1.10 - 0.10 = 1.00$ in.

With 3000 cfm and 1.00 inches, Table PD-35 shows a 1.17 Bhp.

Note: The formula below the table can be used to calculate Fan Motor Heat:

$$\begin{aligned} 3.5 \times \text{Bhp} &= \text{MBh} \\ 3.5 \times 1.17 &= 4.09 \text{ MBh} \\ \text{Net Total Cooling Capacity} &= \\ 92.0 \text{ MBh} - 4.09 &= 87.91 \text{ MBh} \end{aligned}$$

$$\begin{aligned} \text{Net Sensible Cooling Capacity} &= \\ 65.5 \text{ MBh} - 4.09 &= 61.41 \text{ MBh} \end{aligned}$$

Heating Capacity

Step 1 — Calculate the building heating load using the Trane calculation form or any other standard accepted method.

Step 2 — Size the system heating capacity to match the calculated building heating load. The following are building heating requirements:

- a. Total Heating Load: 97.0 MBh
- b. 3000 cfm
- c. Electric Supplementary Heaters

From Table PD-52, the 34.88 Kw heater has a capacity of 119,045 Btuh. From Table ED-5, the 34.88 Kw at 460v indicates the heater model number is BAYHTRL435A. This heater will adequately cover the building's heating requirement.

Air Delivery Selection

External static pressure drop through the air distribution system has been calculated to be 0.77 inches of water gauge. From Table PD-51 static pressure drop through the electric heater is 0.23 inches of water ($0.77 + 0.23 = 1.00$ in.). Enter Table PD-35 for TWE090A4 at 3000 cfm and 1.00 static pressure. The standard motor at 821 RPM will give the desired airflow.

Model Number Description

Split System Heat Pump Model Nomenclature

T T A **1 2 0** **A** **4** **0 0** **E** **A**
1 2 3 4 5 6 7 8 9 10 11 12

Digits 1,2,3 - Product Type

TTA = Split System Cooling

Digits 4,5,6 - Nominal Gross Cooling Capacity (MBh)

- 090 = 7 1/2 Tons
- 120 = 10 Tons
- 150 = 12 1/2 Tons
- 180 = 15 Tons
- 240 = 20 Tons

Digits 7 - Major Development Sequence

- A = 1 Refrigerant Circuit
- B = 2 Refrigerant Circuit
- C = Manifold Scroll Compressors

Digits 8 - Electrical Characteristics

- 3 = 208-230/60/3
- 4 = 460/60/3
- W = 575/60/3
- D = 380-415/50/3
- K = 380/60/3

Digits 9,10 - Factory Installed Options

- 00 = Packed Stock
- 0S = Black Epoxy Coated Coil
- 0R = ReliaTel Controls
- 0T = ReliaTel Controls with Black Epoxy Coated Coil

Digits 11 - Minor Design Sequence

- B = Second

Digits 12 - Service Digit

- A = First

Air Handler Model Nomenclature

T W E **0 9 0** **A** **1** **0 0** **E** **A**
1 2 3 4 5 6 7 8 9 10 11 12

Digits 1,2,3 - Product Type

TWE = Split System Heat Pump/
Cooling Air Handler

Digits 4,5,6 - Nominal Gross Cooling Capacity (MBh)

- 060 = 5 Tons
- 090 = 7 1/2 Tons
- 120 = 10 Tons
- 180 = 15 Tons
- 240 = 20 Tons

Digits 7 - Refrigerant Circuit

- A = Single
- B = Dual

Digits 8 - Electrical Characteristics

- 1 = 208-230/60/1
- 3 = 208-230/60/3
- 4 = 460/60/3
- W = 575/60/3
- K = 380/60/3

Digits 9,10 - Factory Installed Options

- 00 = Packed Stock

Digits 11 - Minor Design Sequence

- E = Current Design Sequence

Digits 12 - Service Digit

- A = First

General Data

Condensing Units

Table GD-1: General Data – 7 1/2, 10 Ton Condensing Units

	7 1/2 Ton	10 Ton	10 Ton	10 Ton
	Single Compressor TTA090A3,A4,AW	Single Compressor TTA120A3,A4,AW	Dual Compressor TTA120B3,B4,BW	Manifolded Compressor TTA120C3,C4,CW
Cooling Performance¹				
Gross Cooling Capacity				
Matched Air Handler	92,000	128,000	126,000	126,000
Condensing Unit Only ²	92,000	128,000	126,000	126,000
ARI Net Cooling Capacity ³	89,000	124,000	122,000	122,000
EER⁴				
Matched Air Handler	10.3	10.3	10.3	10.3
Condensing Unit Only	11.6	11.3	11.5	11.4
System Integrated Part Load Value ⁵	-	-	11.2	12.8
Condensing Unit Only IPLV ⁵	-	-	14.0	14.8
System kW/Condensing Unit kW	8.61/7.90	12.11/11.25	11.89/10.94	11.9/11.1
Compressor				
No./Type	1/Scroll	1/Scroll	2/Scrolls	2/Manifolded Scrolls
No. Motors/HP	1/7.5	1/10	2/5.0	2/5.0
Motor RPM	3450	3450	3450	3450
Sound Rating (BELS)⁶				
	8.6	8.9	8.9	8.9
System Data⁷				
No. Refrigerant Circuits	1	1	2	1
Suction Line (in.) OD	1 3/8	1 3/8	1 1/8	1 3/8
Liquid Line (in.) OD	1/2	1/2	3/8	1/2
Outdoor Coil - Type				
	Plate Fin	Plate Fin	Plate Fin	Plate Fin
Tube Size (in.) OD	.375	.375	.375	.375
Face Area (sq ft)	19.25	24.0	24.0	18.4
Rows/FPI	2/18	2/20	2/20	2/20
Outdoor Fan - Type				
	Propeller	Propeller	Propeller	Propeller
No. Used/Diameter (in.)	1/26	1/28	1/28	1/28
Drive Type/No. Speeds	Direct/1	Direct/1	Direct/1	Direct/1
CFM	5670	8120	8120	8120
No. Motor/HP	1/.50	1/1.00	1/1.00	1/1.00
Motor RPM	1100	1100	1100	1100
Refrigerant Charge (Field Supplied)				
(lbs of R-22) ⁸	16.00	19.0	21.00	20.50

Notes:

- Cooling Performance is rated at 95° F ambient, 80° F entering dry bulb, 67° F entering wet bulb. Gross capacity does not include the effect of fan motor heat. ARI capacity is net and includes the effect of fan motor heat. Certified in accordance with the Unitary Large Equipment certification program, which is based on ARI Standard 340/360-00 or 365-00.
- Condensing unit only gross cooling capacity rated at 45° F saturated suction temperature and at 95° F ambient.
- ARI net cooling capacity is calculated with matched blower coil and 25 feet of 1 3/8" or 1/2" OD interconnecting tubing.
- EER is rated at ARI conditions and in accordance with DOE test procedures.
- Integrated part load value is based on ARI Standard 340/360-00 or 365-00. Units are rated at 80° F ambient, 80° F entering dry bulb (DB), and 67° F entering wet bulb (WB) at ARI rated cfm.
- Sound rating shown is tested in accordance with ARI Standard 270 and 370.
- Refer to refrigerant piping applications manual for line sizing and line length.
- Refrigerant (operating) charge is for condensing unit (all circuits) with matching blower coils and 25 feet of interconnecting refrigerant lines. All units are supplied with a small nitrogen holding charge only.

PRODUCT DATA

American Standard Inc.

General Data Condensing Units

Table GD-2: General Data – 12 1/2, 15 and 20 Ton Condensing Units

	12 1/2 Ton	15 Ton	15 Ton	20 Ton
	Dual Compressor TTA150B3,B4,BW	Dual Compressor TTA180B3,B4,BW	Manifolded Compressor TTA180C3,C4,CW	Dual Compressor TTA240B3,B4,BW
Cooling Performance¹				
Gross Cooling Capacity				
Matched Air Handler	148,000	182,000	182,000	246,000
Condensing Unit Only ²	148,000	182,000	182,000	246,000
ARI Net Cooling Capacity ³	144,000	176,000	176,000	238,000
EER ⁴				
Matched Air Handler	9.8	9.7	9.7	9.7
Condensing Unit Only	11.0	11.1	11.1	11.1
System Integrated Part Load Value ⁵	11.0	10.9	13.0	10.9
Condensing Unit Only IPLV ⁵	13.7	14.0	15.0	14.0
System kW/Condensing Unit kW	14.70/13.43	18.18/16.43	18.16/16.35	24.61/22.17
Compressor				
No./Type	2/Scroll	2/Scroll	2/Scrolls	2/Scrolls
No. Motors/HP	2/6.25	2/7.50	2/7.50	2/10.0
Motor RPM	3450	3450	3450	3450
Sound Rating (BELS)⁶				
	8.6	8.9	8.9	8.9
System Data⁷				
No. Refrigerant Circuits	2	2	1	2
Suction Line (in.) OD	1 1/8	1 3/8	1 5/8	1 3/8
Liquid Line (in.) OD	3/8	1/2	5/8	1/2
Outdoor Coil - Type				
	Plate Fin	Plate Fin	Plate Fin	Plate Fin
Tube Size (in.) OD	.375	.375	.375	.375
Face Area (sq ft)	24.0	33.3	30.7	50.2
Rows/FPI	2/18	2/20	2/20	2/18
Outdoor Fan - Type				
	Propeller	Propeller	Propeller	Propeller
No. Used/Diameter (in.)	1/28	2/26	2/26	2/28
Drive Type/No. Speeds	Direct/1	Direct/1	Direct/1	Direct/1
CFM	8120	10900	11340	16120
No. Motor/HP	1/1.00	2/.50	2/.50	2/1.00
Motor RPM	1100	1100	1100	1100
Refrigerant Charge (Field Supplied)				
(lbs of R-22) ⁸	23.6	30.0	28.00	40.0

Notes:

- 1 Cooling Performance is rated at 95° F ambient, 80° F entering dry bulb, 67° F entering wet bulb. Gross capacity does not include the effect of fan motor heat. ARI capacity is net and includes the effect of fan motor heat. Certified in accordance with the Unitary Large Equipment certification program, which is based on ARI Standard 340/360-00 or 365-00.
- 2 Condensing unit only gross cooling capacity rated at 45° F saturated suction temperature and at 95° F ambient.
- 3 ARI net cooling capacity is calculated with matched blower coil and 25 feet of 1 3/8" or 1/2" OD interconnecting tubing.
- 4 EER is rated at ARI conditions and in accordance with DOE test procedures.
- 5 Integrated part load value is based on ARI Standard 340/360-00 or 365-00. Units are rated at 80° F ambient, 80° F entering dry bulb (DB), and 67° F entering wet bulb (WB) at ARI rated cfm.
- 6 Sound rating shown is tested in accordance with ARI Standard 270.
- 7 Refer to refrigerant piping applications manual for line sizing and line length.
- 8 Refrigerant (operating) charge is for condensing unit (all circuits) with matching blower coils and 25 feet of interconnecting refrigerant lines. All units are supplied with a small nitrogen holding charge only.

General Data

Air Handlers

Table GD-3: General Data – Air Handlers

	5 Ton		7 1/2 Ton		10 Ton	
	Single Circuit TWE060A1,A3,A4,AW	Dual Circuit TWE060B1,B3,B4	Single Circuit TWE090A1,A3 ¹ ,AW	Dual Circuit TWE090B1,B3 ¹	Single Circuit TWE0120A1	Single Circuit TWE120A3 ¹ ,A4,AW
System Data						
No. Refrigerant Circuits	1	2	1	2	1	1
Suction Line (in.) OD	1 1/8	3/4	1 3/8	1 1/8	1 3/8	1 3/8
Liquid Line (in.) OD	3/8	5/16	1/2	3/8	1/2	1/2
Indoor Coil - Type						
	Plate Fin	Plate Fin	Plate Fin	Plate Fin	Plate Fin	Plate Fin
Tube Size (in.)	.375	.375	.375	.375	.375	.375
Face Area (sq. ft.)	5.0	5.0	8.1	8.1	11.2	11.2
Rows/FPI	3/12	3/12	3/12	3/12	4/12	4/12
Refrigerant Control	Expansion Valve	Expansion Valve	Expansion Valve	Expansion Valve	Expansion Valve	Expansion Valve
Drain Connection Size (in.)	1 PVC	1 PVC	1 PVC	1 PVC	1 PVC	1 PVC
Indoor Fan - Type						
	Centrifugal	Centrifugal	Centrifugal	Centrifugal	Centrifugal	Centrifugal
No. Used/Diameter x Width (in.)	1/12 x 12	1/12 x 12	1/15 x 15	1/15 x 15	1/15 x 15	1/15 x 15
Drive Type/No. Speeds	Belt/Adjustable	Belt/Adjustable	Belt/Adjustable	Belt/Adjustable	Belt/Adjustable	Belt/Adjustable
CFM	2000	2000	3000	3000	4000	4000
No. Motors	1	1	1	1	1	1
Motor HP - Standard/Oversized	.75/1.00	.75/1.00	1.50/2.00	1.50/2.00	2.00/3.00	2.00/3.00
Motor RPM	1725	1725	1725	1725	1725	1725
Motor Frame Size	56	56	56H	56H	56HZ	56HZ
Filters - Type/Furnished						
(No.)/Size Recommended	Throwaway/Yes (1) 16 x 20 x 1 (1) 20 x 20 x 1	Throwaway/Yes (1) 16 x 20 x 1 (1) 20 x 20 x 1	Throwaway/Yes (3) 16 x 25 x 1	Throwaway/Yes (3) 16 x 25 x 1	Throwaway/Yes (4) 16 x 25 x 1	Throwaway/Yes (4) 16 x 25 x 1

ARI tested and certified with various heat pumps per ARI Standard 210/240 or 340/360 or 365-00 certification program. Refer to performance data section in this catalog.

Notes:

- 1 Ships wired for 208-230/60/3. Field convertible to 460/60/3.
- 2 TWE060A1 has motor RPM of 3450 for oversized motor.
- 3 TWE120A1 does not have an oversized motor option.

Table GD-3: General Data – Air Handlers (continued)

	10 Ton		15 Ton		20 Ton
	Dual Circuit TWE120B1,B3 ¹ ,B4	Dual Circuit TWE120BW	Dual Circuit TXE120B500B	Dual Circuit TWE180B3,B4,BW	Dual Circuit TWE240B3,B4,BW
System Data					
No. Refrigerant Circuits	2	2	2	2	2
Suction Line (in.) OD	1 1/8	1 1/8	1 1/8	1 3/8	1 3/8
Liquid Line (in.) OD	3/8	3/8	3/8	1/2	1/2
Indoor Coil - Type					
	Plate Fin	Plate Fin	Plate Fin	Plate Fin	Plate Fin
Tube Size (in.)	.375	.375	.375	.375	.375
Face Area (sq. ft.)	11.2	11.2	11.2	16.3	21.6
Rows/FPI	4/12	4/12	4/12	3/12	3/12
Refrigerant Control	Expansion Valve	Expansion Valve	Expansion Valve	Expansion Valve	Expansion Valve
Drain Connection Size (in.)	1 PVC	1 PVC	1 PVC	1 PVC	1 PVC
Indoor Fan - Type					
	Centrifugal	Centrifugal	-	Centrifugal	Centrifugal
No. Used/Diameter x Width (in.)	1/15 x 15	1/15 x 15	-	2/15 x 15	2/15 x 15
Drive Type/No. Speeds	Belt/Adjustable	Belt/Adjustable	-	Belt/Adjustable	Belt/Adjustable
CFM	4000	4000	-	6000	8000
No. Motors	1	1	-	1	1
Motor HP - Standard/Oversized	2.00/-	2.00/3.00	-	3.00/5.00	5.00/7.50
Motor RPM	1725	1725	-	1735/1750	1750/3470
Motor Frame Size	56HZ	56HZ	-	145T	184T
Filters - Type/Furnished					
(No.)/Size Recommended	Throwaway/Yes (4) 16 x 25 x 1	Throwaway/Yes (4) 16 x 25 x 1	Throwaway/No ² (4) 16 x 25 x 1	Throwaway/Yes (8) 15 x 20 x 2	Throwaway/Yes (4) 16 x 25 x 2 (4) 16 x 20 x 2

ARI tested and certified with various heat pumps per ARI Standard 210/240 or 340/360 or 365-00 certification program. Refer to performance data section in this catalog.

Notes:

- 1 Ships wired for 208-230/60/3. Field convertible to 460/60/3
- 2 Coil has filter rack as standard, but no filters. When using this coil as a duct coil, use below size recommended. Filters for coil not recommended when using coil with upflow gas furnaces.

PRODUCT DATA

American Standard Inc.

Performance Data

7 1/2 Tons

Table PD-1: Gross Cooling Capacities (MBh) 7 1/2 Ton TTA090A Condensing Unit with 7 1/2 Ton TWE090A Air Handler

CFM Airflow	Enter. DB (° F)	Ambient Temperature																							
		85						95						105						115					
		Entering WB																							
		61		67		73		61		67		73		61		67		73		61		67		73	
MBH	SHC	MBH	SHC	MBH	SHC	MBH	SHC	MBH	SHC	MBH	SHC	MBH	SHC	MBH	SHC	MBH	SHC	MBH	SHC	MBH	SHC	MBH	SHC		
2700	75	85	66.9	93.8	56.6	103.2	38.1	81.8	65.3	90.3	55.2	99.3	36.8	78.3	63.5	86.4	53.6	95.2	35.3	74.5	61.7	82.3	52	90.7	33.8
	80	85.4	77.9	94.1	64.4	103.2	49.8	82.3	76.4	90.5	62.9	99.4	48.3	78.9	74.7	86.7	61.2	95.2	46.8	75.3	72.8	82.5	59.3	90.8	45.1
	85	87.1	87.1	94.2	75.3	103.4	61.2	84.5	84.5	90.7	73.7	99.6	59.7	81.6	81.6	86.8	72	95.4	58.2	78.4	78.4	82.7	70.2	91	56.5
	90	91.5	91.5	94.6	86.4	103.6	72.5	88.8	88.8	91.3	84.9	99.6	70.9	85.8	85.8	87.6	83.2	95.5	69.3	82.5	82.5	83.7	81.5	91.1	67.5
3000	75	86.7	69.9	95.5	54.9	104.9	38.8	83.3	68.3	91.9	53.3	100.9	37.5	79.7	66.5	87.9	51.7	96.6	35.9	75.8	64.6	83.6	49.9	92	34.3
	80	87.3	82	95.7	67.2	104.9	51.4	84.1	80.4	92	65.5	100.9	49.9	80.6	78.7	88	63.8	96.7	48.3	77	76.9	83.8	61.9	92.1	46.7
	85	89.9	89.9	95.9	79	105.1	63.8	87.2	87.2	92.2	77.4	101.1	62.3	84.1	84.1	88.3	75.7	96.9	60.8	80.8	80.8	84.2	73.9	92.4	59.1
	90	94.5	94.5	96.6	91.2	105.2	75.9	91.6	91.6	93.1	89.7	101.2	74.3	88.4	88.4	89.4	88.0	97.0	72.7	85.0	85.0	85.1	85.1	92.5	70.9
3300	75	88.1	72.7	96.9	56.6	106.2	39.5	84.6	71.1	93.1	55.1	102.1	38	80.9	69.3	89.1	53.4	97.7	36.4	76.9	67.4	84.7	51.7	93	34.7
	80	88.9	85.9	97	69.7	106.3	52.9	85.7	84.3	93.3	68.1	102.2	51.4	81.8	81.8	89.2	66.3	97.9	49.8	78.4	78.4	84.9	64.5	93.2	48.2
	85	92.4	92.4	97.3	82.6	106.5	66.3	89.5	89.5	93.6	81	102.4	64.8	86.3	86.3	89.6	79.3	98.1	63.2	82.8	82.8	85.4	77.4	93.3	61.3
	90	97.0	97.0	98.4	95.9	106.6	79.2	94.0	94.0	94.9	94.3	102.6	77.6	90.8	90.8	90.8	90.8	98.2	75.9	87.2	87.2	87.3	87.3	93.6	74.2
3600	75	89.2	75.5	98.0	58.3	107.4	40.0	85.8	73.8	94.2	56.7	103.2	38.5	82.0	72.0	90.1	55.1	98.7	36.9	77.9	70.0	85.6	53.3	93.9	35.2
	80	90.5	89.7	98.2	72.2	107.5	54.3	86.8	86.8	94.4	70.5	103.3	52.8	83.6	83.6	90.3	68.8	98.9	51.2	80.1	80.1	85.9	66.9	94.2	49.6
	85	94.5	94.5	98.5	86.0	107.7	68.6	91.5	91.5	94.8	84.4	103.5	67.2	88.2	88.2	90.8	82.7	99.0	65.3	84.6	84.6	86.5	80.8	94.3	63.5
	90	99.3	99.3	99.3	99.3	107.8	82.4	96.2	96.2	96.3	96.3	103.7	80.8	92.8	92.8	92.9	92.9	99.3	79.1	89.2	89.2	89.2	89.2	94.6	77.3

Equal MBH and SHC values constitute dry coil condition. Total Gross Cooling Capacity (MBh) shown to the left is not applicable. In this case the Sensible Heat Capacity (SHC) is the total capacity.

All capacities shown are gross and have not considered indoor fan heat.

To obtain net cooling capacities, subtract indoor fan heat.

MBH = Total Gross Cooling Capacity

SHC = Sensible Heat Capacity

Table PD-2: Gross Cooling Capacities (MBh) 7 1/2 Ton TTA090A Condensing Unit with 10 Ton TWE120A Air Handler

CFM Airflow	Enter. DB (° F)	Ambient Temperature																							
		85						95						105						115					
		Entering WB																							
		61		67		73		61		67		73		61		67		73		61		67		73	
MBH	SHC	MBH	SHC	MBH	SHC	MBH	SHC	MBH	SHC	MBH	SHC	MBH	SHC	MBH	SHC	MBH	SHC	MBH	SHC	MBH	SHC	MBH	SHC		
3100	75	90.8	73.8	99.9	61.9	109.7	40.7	87.4	72.1	96.2	60.4	105.6	39.3	83.4	70.2	92.1	58.8	101.2	37.8	79.2	68.2	87.7	57.1	96.5	36.2
	80	91.4	86.7	100.2	70.8	109.7	54	88.1	85.1	96.4	69.3	105.7	52.5	84.4	83.3	92.3	67.4	101.4	50.9	80.3	80.3	87.9	65.5	96.7	49.2
	85	94.5	94.5	100.3	83.5	109.9	67.2	91.6	91.6	96.6	81.9	105.9	65.7	88.4	88.4	92.5	80.1	101.6	64.1	84.9	84.9	88.2	78.3	97	62.4
	90	99.2	99.2	101	96.5	110.1	80.3	96.2	96.2	97.5	95	106	78.6	92.9	92.9	93.6	93.3	101.7	76.9	89.4	89.4	89.6	89.6	97.1	75.1
3400	75	92.2	76.8	101.4	59.5	111.1	41.3	88.7	75.1	97.6	58	106.9	39.8	84.7	73.2	93.4	56.3	102.4	38.2	80.4	71.2	88.9	54.5	97.6	36.5
	80	93.1	90.9	101.6	73.7	111.2	55.6	89.7	89.3	97.7	71.9	107.1	54.1	85.9	85.9	93.5	70.1	102.6	52.5	82.3	82.3	89.1	68.2	97.9	50.8
	85	97.0	97.0	101.7	87.3	111.4	69.8	94.0	94.0	98.0	85.7	107.2	68.3	90.7	90.7	93.9	83.9	102.9	66.7	87.1	87.1	89.5	82.0	98.1	65.1
	90	101.8	101.8	102.8	101.5	111.4	83.6	98.8	98.8	98.9	98.9	107.3	82.1	95.4	95.4	95.5	95.5	103	80.4	91.8	91.8	91.9	91.9	98.3	78.6
3700	75	93.4	79.8	102.6	61.3	112.2	41.8	89.8	78	98.7	59.7	108	40.3	85.8	76.1	94.4	58	103.4	38.7	81.5	74.1	89.9	56.2	98.5	37
	80	94.2	94.2	102.7	76.2	112.4	57.1	91.2	91.2	98.8	74.5	108.2	55.6	87.8	87.8	94.6	72.7	103.7	54	84.2	84.2	90.1	70.8	98.9	52.3
	85	99.2	99.2	103	91.0	112.6	72.3	96.1	96.1	99.2	89.4	108.4	70.8	92.7	92.7	95.1	87.6	103.9	69.3	89.0	89.0	90.7	85.7	99.0	67.2
	90	104.2	104.2	104.3	104.3	112.7	87.0	101	101	101.1	101.1	108.5	85.4	97.6	97.6	97.6	97.6	104	83.8	93.8	93.8	93.8	93.9	93.9	99.3
4000	75	94.5	82.6	103.6	63	113.2	42.3	90.8	80.8	99.7	61.4	108.9	40.7	86.8	78.9	95.3	59.7	104.2	39.2	82.5	76.9	90.7	57.9	99.3	37.5
	80	96.1	96.1	103.8	78.7	113.4	58.5	93.0	93.0	99.8	77.1	109.1	57.0	89.5	89.5	95.5	75.3	104.6	55.5	85.8	85.8	90.9	73.3	99.7	53.8
	85	101.2	101.2	104.2	94.5	113.6	74.8	98.0	98.0	100.4	92.9	109.2	73.0	94.5	94.5	96.2	91.1	104.7	71.3	90.7	90.7	91.8	89.3	99.9	69.5
	90	106.3	106.3	106.4	106.4	113.7	90.3	103.0	103.0	103.1	103.1	109.4	88.7	99.5	99.5	99.6	99.6	105	87.0	95.6	95.6	95.6	95.7	100.2	85.3

Equal MBH and SHC values constitute dry coil condition. Total Gross Cooling Capacity (MBh) shown to the left is not applicable. In this case the Sensible Heat Capacity (SHC) is the total capacity.

All capacities shown are gross and have not considered indoor fan heat.

To obtain net cooling capacities, subtract indoor fan heat.

MBH = Total Gross Cooling Capacity

SHC = Sensible Heat Capacity

Performance Data

10 Tons

Table PD-3: Gross Cooling Capacities (MBh) 10 Ton TTA120A Condensing Unit with 10 Ton TWE120A Air Handler

CFM Airflow	Enter. DB (° F)	Ambient Temperature																							
		85						95						105						115					
		Entering WB																							
		61		67		73		61		67		73		61		67		73		61		67		73	
MBH	SHC	MBH	SHC	MBH	SHC	MBH	SHC	MBH	SHC	MBH	SHC	MBH	SHC	MBH	SHC	MBH	SHC	MBH	SHC	MBH	SHC	MBH	SHC		
3600	75	117.7	91.3	129.9	77.1	143.5	52.5	113.3	89.0	125.4	75.2	138.4	50.8	108.8	86.7	120.5	73.3	133.1	48.9	104.0	84.3	115.3	71.2	127.4	47.0
	80	118.1	105.8	130.3	87.6	143.5	68.3	114.0	103.7	125.8	85.6	138.5	66.4	109.6	101.5	120.9	83.6	133.2	64.4	105.0	99.2	115.8	81.4	127.6	62.3
	85	119.6	119.6	130.4	102.4	143.8	83.5	116.2	116.2	125.9	100.4	138.8	81.6	112.5	112.5	121.1	98.2	133.5	79.6	108.6	108.6	116.0	95.9	127.9	77.5
	90	125.6	125.6	131.0	117.2	144.0	98.6	122.1	122.1	126.6	115.2	139.1	96.7	118.4	118.4	122.0	113.1	133.8	94.7	114.4	114.4	117.1	110.9	128.3	92.7
4000	75	119.9	95.2	132.4	75.0	145.9	53.6	115.6	93.0	127.7	73.0	140.8	51.8	111.0	90.7	122.7	70.9	135.2	49.9	106.0	88.3	117.4	68.7	129.4	47.8
	80	120.8	111.3	132.8	91.5	146.0	70.4	116.6	109.2	128.1	89.5	140.9	68.5	112.2	107.0	123.1	87.4	135.4	66.5	107.4	104.7	117.8	85.2	129.6	64.4
	85	123.5	123.5	132.9	107.5	146.3	87.0	120.0	120.0	128.2	105.4	141.2	85.1	116.2	116.2	123.3	103.2	135.8	83.1	112.1	112.1	118.0	100.9	130.0	81.0
	90	129.9	129.9	133.9	123.7	146.6	103.5	122.2	126.2	129.4	121.7	141.5	101.6	122.3	122.3	124.7	119.5	136.1	99.6	118.1	118.1	119.7	117.3	130.1	97.0
4400	75	121.9	99.0	134.5	77.3	148.0	54.6	117.5	96.8	129.6	75.3	142.7	52.7	112.7	94.5	124.5	73.2	137.0	50.6	107.6	92.1	119.0	71.0	130.9	48.5
	80	123.1	116.6	134.8	95.2	148.1	72.5	118.9	114.5	130.0	93.1	142.8	70.6	114.4	112.3	124.8	91.0	137.2	68.5	108.9	108.9	119.2	88.4	131.3	66.4
	85	127.0	127.0	135.0	112.3	148.4	90.4	123.4	123.4	130.2	110.2	143.2	88.4	119.4	119.4	125.2	108.0	137.6	86.4	115.1	115.1	119.9	105.7	131.7	84.3
	90	133.6	133.6	136.4	129.9	148.7	108.2	129.7	129.7	131.9	127.9	143.3	105.8	125.7	125.7	127.1	125.8	137.7	103.7	118.1	118.1	121.4	121.4	131.9	101.4
4800	75	123.6	102.7	136.2	79.6	149.7	55.3	119.1	100.5	131.2	77.6	144.2	53.3	114.3	98.2	126.0	75.5	138.4	51.3	109.2	95.7	120.4	73.2	132.2	49.1
	80	125.2	121.6	136.5	98.7	149.9	74.4	121.0	119.5	131.4	96.3	144.5	72.5	115.7	115.7	126.2	94.0	138.7	70.5	111.4	111.4	120.7	91.7	132.7	68.3
	85	130.2	130.2	136.9	116.9	150.2	93.6	126.3	126.3	132.0	114.8	144.8	91.6	122.2	122.2	127.0	112.6	139.1	89.6	117.8	117.8	121.6	110.3	133.1	87.5
	90	136.9	136.9	138.8	136.0	150.3	112.2	132.9	132.9	134.2	133.9	145.0	110.1	128.7	128.7	128.8	128.8	139.3	108.0	124.1	124.1	124.3	124.3	133.3	105.7

Equal MBH and SHC values constitute dry coil condition. Total Gross Cooling Capacity (MBh) shown to the left is not applicable. In this case the Sensible Heat Capacity (SHC) is the total capacity.

All capacities shown are gross and have not considered indoor fan heat.
To obtain net cooling capacities, subtract indoor fan heat.
MBH = Total Gross Cooling Capacity
SHC = Sensible Heat Capacity

Table PD-4: Gross Cooling Capacities (MBh) 10 Ton TTA120B Condensing Unit with 10 Ton TWE120B Air Handler

CFM Airflow	Enter. DB (° F)	Ambient Temperature																							
		85						95						105						115					
		Entering WB																							
		61		67		73		61		67		73		61		67		73		61		67		73	
MBH	SHC	MBH	SHC	MBH	SHC	MBH	SHC	MBH	SHC	MBH	SHC	MBH	SHC	MBH	SHC	MBH	SHC	MBH	SHC	MBH	SHC	MBH	SHC		
3600	75	114.9	89.9	127.2	76.2	140.5	52.0	111.2	88.0	123.1	74.5	135.7	50.3	107.3	86.0	118.5	72.7	130.2	48.5	103.1	83.8	113.6	70.7	124.1	46.2
	80	115.6	104.7	127.9	87.2	141.1	68.0	112.0	102.8	123.8	85.5	136.5	66.2	108.2	100.8	118.9	82.9	131.3	64.3	104.1	98.7	114.0	80.7	125.4	62.1
	85	117.8	117.8	128.2	101.6	141.8	83.4	114.7	114.7	124.2	99.7	137.2	81.6	111.5	111.5	119.7	97.6	132.1	79.7	107.9	107.9	114.8	95.4	126.3	77.5
	90	124.0	124.0	129.0	116.5	142.3	98.7	120.9	120.9	125.0	114.6	137.4	96.4	117.4	117.4	120.7	112.6	132.3	94.3	113.6	113.6	115.9	110.3	126.6	91.9
4000	75	117.3	93.9	129.8	74.5	142.8	52.9	113.5	92.0	125.5	72.7	137.7	51.2	109.4	89.9	120.7	70.7	132.1	49.3	105.0	87.7	115.6	68.6	125.7	47.1
	80	118.3	110.2	130.0	90.6	143.7	70.2	114.6	108.2	125.8	88.7	138.9	68.5	110.6	106.2	121.1	86.5	133.5	66.5	106.4	104.0	116.0	84.2	127.3	64.2
	85	121.8	121.8	130.8	106.7	144.4	87.0	118.6	118.6	126.6	104.7	139.7	85.3	115.1	115.1	121.9	102.6	134.4	83.3	111.2	111.2	116.8	100.2	128.3	81.0
	90	128.3	128.3	131.9	123.0	144.6	102.9	125.0	125.0	127.9	121.1	140.0	101.0	121.4	121.4	123.4	119.0	134.7	98.9	117.2	117.2	118.4	116.7	128.7	96.4
4400	75	119.3	97.7	131.8	76.9	144.5	53.9	115.3	95.7	127.4	75.1	139.4	52.1	111.2	93.6	122.5	73.1	133.6	50.2	106.6	91.3	117.1	70.9	127.0	47.9
	80	120.6	115.4	132.2	94.1	145.8	72.3	116.9	113.4	127.8	92.1	140.9	70.5	112.9	111.4	123.0	89.9	135.3	68.5	108.0	108.0	117.7	87.5	128.9	66.3
	85	125.3	125.3	133.0	111.4	146.6	90.5	122.0	122.0	128.7	109.5	141.8	88.7	118.3	118.3	123.9	107.3	136.2	86.7	114.2	114.2	118.6	104.9	129.5	83.4
	90	132.1	132.1	134.5	129.2	146.9	107.4	128.7	128.7	130.4	127.3	142.2	105.5	124.8	124.8	125.9	125.2	136.7	103.2	120.4	120.4	120.5	120.5	130.5	100.7
4800	75	121.0	101.4	133.6	79.2	146.1	54.8	117.0	99.3	129.0	77.4	140.9	52.9	112.7	97.2	124.0	75.3	134.9	50.8	108.0	94.8	117.8	72.3	128.1	48.5
	80	122.8	120.4	134.1	97.4	147.6	74.3	119.0	118.5	129.6	95.4	142.6	72.5	114.5	114.5	124.6	93.2	136.8	70.5	110.4	110.4	119.1	90.7	130.3	68.2
	85	128.5	128.5	134.9	116.0	148.4	93.7	125.0	125.0	130.5	114.1	143.0	91.2	121.1	121.1	125.6	111.8	137.4	88.9	116.7	116.7	120.2	109.4	131.0	86.3
	90	135.5	135.5	137.0	135.2	148.8	111.6	131.9	131.9	132.0	132.0	144.0	109.7	127.8	127.8	127.9	127.9	138.4	107.4	123.2	123.2	123.3	123.3	132.0	104.9

Equal MBH and SHC values constitute dry coil condition. Total Gross Cooling Capacity (MBh) shown to the left is not applicable. In this case the Sensible Heat Capacity (SHC) is the total capacity.

All capacities shown are gross and have not considered indoor fan heat.
To obtain net cooling capacities, subtract indoor fan heat.
MBH = Total Gross Cooling Capacity
SHC = Sensible Heat Capacity

PRODUCT DATA

American Standard Inc.

Performance Data

10 Tons

Table PD-5: Gross Cooling Capacities (MBh) – Both Compressors – 10 Ton TTA120C Condensing Unit with 10 Ton TWE120A Air Handler

CFM Airflow	Enter. DB (° F)	Ambient Temperature																							
		85						95						105						115					
		Entering WB																							
		61		67		73		61		67		73		61		67		73		61		67		73	
MBH	SHC	MBH	SHC	MBH	SHC	MBH	SHC	MBH	SHC	MBH	SHC	MBH	SHC	MBH	SHC	MBH	SHC	MBH	SHC	MBH	SHC	MBH	SHC		
3600	75	115.5	90.4	127.7	76.4	140.9	51.9	111.8	88.5	123.6	74.8	136.3	50.4	107.9	86.5	119.1	73.0	131.1	48.6	103.7	84.4	114.2	71.0	125.1	46.6
	80	116.2	105.2	128.3	87.3	141.1	67.9	112.6	103.4	124.2	85.6	136.7	66.2	108.8	101.4	119.7	83.7	131.6	64.3	104.7	99.3	114.8	81.6	125.8	62.1
	85	118.3	118.3	128.5	102.0	141.5	83.2	115.2	115.2	124.5	100.1	137.1	81.6	112.0	112.0	120.0	98.1	132.2	79.7	108.3	108.3	115.1	95.8	126.4	77.5
	90	124.4	124.4	129.3	116.9	141.9	98.5	121.2	121.2	125.4	115.0	137.6	96.8	117.8	117.8	121.0	113.0	132.6	95.0	113.9	113.9	116.3	110.8	126.6	92.2
4000	75	117.9	94.5	130.2	74.6	143.1	53.0	114.0	92.5	126.0	72.8	138.4	51.4	110.0	90.5	121.3	70.8	133.0	49.5	105.5	88.2	116.1	68.7	126.7	47.4
	80	118.9	110.7	130.7	91.3	143.5	70.1	115.2	108.8	126.5	89.5	139.0	68.4	111.3	106.8	121.5	87.0	133.7	66.4	107.0	104.7	116.4	84.7	127.7	64.3
	85	122.2	122.2	131.0	107.0	144.0	86.8	119.0	119.0	126.8	105.1	139.5	85.1	115.6	115.6	122.2	103.0	134.3	83.2	111.7	111.7	117.1	100.7	128.3	81.0
	90	128.6	128.6	132.1	123.3	144.4	103.4	125.3	125.3	128.1	121.5	139.6	101.2	121.6	121.6	123.7	119.5	134.5	99.1	117.5	117.5	118.8	117.2	128.6	96.7
4400	75	119.9	98.3	132.2	77.0	145.0	54.0	115.9	96.3	127.9	75.2	140.1	52.3	111.7	94.2	123.0	73.2	134.5	50.3	107.1	91.9	117.7	71.0	128.1	48.0
	80	121.3	116.0	132.5	94.5	145.5	72.1	117.5	114.1	128.1	92.6	140.8	70.4	113.5	112.0	123.3	90.4	135.4	68.5	108.5	108.5	118.0	88.0	129.2	66.3
	85	125.7	125.7	133.0	111.8	146.1	90.2	122.4	122.4	128.8	109.9	141.4	88.5	118.7	118.7	124.1	107.8	136.0	86.5	114.5	114.5	118.9	105.4	129.9	84.3
	90	132.2	132.2	134.6	129.6	146.2	107.4	128.8	128.8	130.7	127.8	141.6	105.6	125.0	125.0	126.1	125.7	136.3	103.5	120.6	120.6	120.7	120.7	130.2	101.0
4800	75	121.6	102.0	133.9	79.3	146.6	54.7	117.6	100.0	129.5	77.5	141.5	52.9	113.2	97.8	124.5	75.5	135.8	50.9	108.6	95.5	119.0	73.3	129.2	48.7
	80	123.4	121.1	134.2	97.8	147.2	74.1	119.6	119.2	129.8	95.9	142.4	72.4	115.0	115.0	124.9	93.7	136.9	70.4	110.9	110.9	119.4	91.2	130.5	68.2
	85	128.8	128.8	134.9	116.4	147.8	93.4	125.3	125.3	130.7	114.5	143.0	91.7	121.4	121.4	125.8	112.4	137.5	89.7	117.1	117.1	120.5	110.0	130.9	86.7
	90	135.5	135.5	137.0	135.6	148.1	111.7	131.9	131.9	132.0	132.0	143.3	109.8	127.9	127.9	128.0	128.0	137.8	107.7	123.3	123.3	123.4	123.4	131.6	105.2

Equal MBH and SHC values constitute dry coil condition. Total Gross Cooling Capacity (MBh) shown to the left is not applicable. In this case the Sensible Heat Capacity (SHC) is the total capacity.

All capacities shown are gross and have not considered indoor fan heat.

To obtain net cooling capacities, subtract indoor fan heat.

MBH = Total Gross Cooling Capacity

SHC = Sensible Heat Capacity

Table PD-6: Gross Cooling Capacities (MBh) – One Compressor – 10 Ton TTA120C Condensing Unit with 10 Ton TWE120A Air Handler

CFM Airflow	Enter. DB (° F)	Ambient Temperature																							
		85						95						105						115					
		Entering WB																							
		61		67		73		61		67		73		61		67		73		61		67		73	
MBH	SHC	MBH	SHC	MBH	SHC	MBH	SHC	MBH	SHC	MBH	SHC	MBH	SHC	MBH	SHC	MBH	SHC	MBH	SHC	MBH	SHC	MBH	SHC		
3600	75	72.7	70.1	79.6	51.9	87.2	33.9	70.0	68.9	76.5	50.6	83.8	32.6	67.0	67.0	73.3	49.3	80.2	31.5	64.2	64.2	69.9	47.8	76.3	30.2
	80	76.3	76.3	80.0	66.7	87.7	48.5	73.8	73.8	76.9	65.4	84.4	47.4	71.2	71.2	73.7	64.1	80.7	45.8	68.4	68.4	70.4	62.7	77.0	44.4
	85	80.7	80.7	80.8	80.8	88.0	63.1	78.2	78.2	78.3	78.3	84.6	61.9	75.5	75.5	75.5	81.2	60.6	72.6	72.6	72.6	72.6	76.6	77.5	59.3
	90	85.2	85.2	85.3	85.3	88.3	78.1	82.6	82.6	82.7	82.7	85.0	76.9	79.8	79.8	79.9	79.9	81.7	75.6	76.8	76.8	76.9	76.9	78.1	74.3
4000	75	73.6	73.6	80.5	54.0	88.0	33.7	71.1	71.1	77.4	52.7	84.5	32.6	68.5	68.5	74.1	51.3	80.8	31.4	65.6	65.6	70.6	49.9	76.9	30.1
	80	78.1	78.1	80.9	70.2	88.6	50.5	75.6	75.6	77.8	68.9	85.2	49.4	72.8	72.8	74.6	67.6	81.7	48.2	69.9	69.9	71.2	66.2	77.9	47.0
	85	82.7	82.7	82.8	82.8	88.9	66.3	80.1	80.1	80.1	80.1	85.5	65.1	77.2	77.2	77.3	77.3	82.0	63.8	74.2	74.2	74.3	74.3	78.2	62.4
	90	87.3	87.3	87.4	87.4	89.4	82.6	84.6	84.6	84.7	84.7	86.1	81.4	81.7	81.7	81.8	81.8	82.7	80.2	78.6	78.6	78.7	78.7	79.2	78.9
4400	75	75.0	75.0	81.3	56.0	88.7	34.3	72.5	72.5	78.1	54.7	85.1	33.2	69.8	69.8	74.8	53.3	81.3	32.0	66.9	66.9	71.2	51.8	77.3	30.7
	80	79.7	79.7	81.8	73.5	89.4	52.4	77.0	77.0	78.7	72.3	85.9	51.3	74.2	74.2	75.4	70.9	82.3	50.1	71.2	71.2	72.0	69.5	78.5	48.9
	85	84.4	84.4	84.5	84.5	89.7	69.3	81.7	81.7	81.7	81.7	86.2	68.1	78.7	78.7	78.8	78.8	82.6	66.8	75.6	75.6	75.7	75.7	78.9	65.4
	90	89.2	89.2	89.2	89.2	90.4	87.1	86.3	86.3	86.4	86.4	87.1	85.8	83.3	83.3	83.4	83.4	83.4	83.4	80.1	80.1	80.2	80.2	80.2	80.2
4800	75	76.3	76.3	81.9	57.9	89.2	34.9	73.7	73.7	78.7	56.6	85.6	33.7	70.9	70.9	75.3	55.2	81.7	32.5	67.9	67.9	71.8	53.7	77.6	31.2
	80	81.1	81.1	82.5	76.8	90.0	54.3	78.3	78.3	79.4	75.5	86.5	53.1	75.4	75.4	76.2	74.1	82.9	52.0	72.4	72.4	72.8	72.7	79.0	50.7
	85	85.9	85.9	85.9	85.9	90.3	72.3	83.0	83.0	83.1	83.1	86.8	71.0	80.1	80.1	80.1	80.1	83.2	69.7	76.9	76.9	76.9	76.9	79.4	68.3
	90	90.7	90.7	90.8	90.8	91.4	91.3	87.8	87.8	87.9	87.9	87.9	87.9	84.7	84.7	84.8	84.8	84.8	84.8	81.4	81.4	81.5	81.5	81.6	81.6

Equal MBH and SHC values constitute dry coil condition. Total Gross Cooling Capacity (MBh) shown to the left is not applicable. In this case the Sensible Heat Capacity (SHC) is the total capacity.

All capacities shown are gross and have not considered indoor fan heat.

To obtain net cooling capacities, subtract indoor fan heat.

MBH = Total Gross Cooling Capacity

SHC = Sensible Heat Capacity

Performance Data

12-1/2, 15 Tons

Table PD-7: Gross Cooling Capacities (MBh) – 12 1/2 Ton TTA150B Condensing Unit with 15 Ton TWE180B Air Handler

CFM Airflow	Enter. DB (° F)	Ambient Temperature																							
		85						95						105						115					
		Entering WB																							
		61		67		73		61		67		73		61		67		73		61		67		73	
MBH	SHC	MBH	SHC	MBH	SHC	MBH	SHC	MBH	SHC	MBH	SHC	MBH	SHC	MBH	SHC	MBH	SHC	MBH	SHC	MBH	SHC	MBH	SHC		
4500	75	137.6	109.2	151.2	92.0	165.6	61.5	132.5	106.7	145.7	89.8	159.5	59.4	127.1	103.9	139.8	87.4	152.9	57.1	121.2	101.0	133.6	84.9	146.0	54.8
	80	138.3	127.6	151.5	104.9	166.0	81.0	133.3	125.1	146.0	102.4	160.1	78.8	128.1	122.5	140.2	99.8	153.7	76.4	122.5	119.6	134.1	97.0	147.1	74.0
	85	141.8	141.8	152.1	123.2	166.6	100.2	137.5	137.5	146.6	120.7	160.7	97.9	133.0	133.0	140.8	118.0	154.4	95.6	128.2	128.2	134.7	115.3	147.5	92.6
	90	148.8	148.8	152.9	141.7	166.9	118.3	144.5	144.5	147.6	139.3	161.0	115.9	139.8	139.8	142.0	136.7	154.8	113.4	134.9	134.9	136.2	134.1	148.3	110.8
5000	75	140.2	114.2	153.8	89.5	168.0	62.5	134.9	111.6	148.1	87.2	161.7	60.3	129.4	108.8	142.0	84.7	155.0	58.1	123.3	105.8	135.7	82.1	148.0	55.6
	80	141.2	134.4	154.2	109.4	168.7	83.7	136.1	131.8	148.5	106.9	162.5	81.5	130.8	129.2	142.5	104.2	156.1	79.1	125.0	125.0	136.3	101.4	149.2	76.7
	85	146.2	146.2	154.8	129.4	169.3	104.6	141.8	141.8	149.1	126.8	162.8	101.7	137.0	137.0	143.2	124.1	156.4	99.2	132.0	132.0	137.0	121.4	149.7	96.5
	90	153.5	153.5	155.9	149.7	169.6	124.1	149.0	149.0	150.6	147.3	163.8	121.6	144.1	144.1	145.0	144.7	157.2	119.1	139.0	139.0	139.2	139.2	150.5	116.4
5500	75	142.3	118.9	155.9	92.5	170.0	63.6	136.9	116.2	150.1	90.1	163.5	61.3	131.2	113.4	143.9	87.6	156.7	58.9	125.2	110.4	137.0	84.2	149.5	56.4
	80	143.8	140.9	156.4	113.7	170.8	86.3	138.7	138.3	150.6	111.1	164.6	84.0	133.2	133.2	144.5	108.4	157.9	81.6	128.1	128.1	138.1	105.5	151.0	79.2
	85	150.1	150.1	157.0	135.3	171.2	108.0	145.5	145.5	151.3	132.7	164.9	105.6	140.5	140.5	145.2	130.0	158.4	103.0	135.3	135.3	139.0	127.3	151.6	100.2
	90	157.6	157.6	158.8	157.4	171.9	129.6	152.9	152.9	153.0	153.0	165.7	127.1	147.9	147.9	148.0	148.0	159.2	124.5	142.6	142.6	142.7	142.7	152.4	121.8
6000	75	144.2	123.4	157.7	95.3	171.6	64.4	138.7	120.7	151.4	92.3	165.1	62.1	132.9	117.8	145.1	89.5	158.1	59.7	126.8	114.8	138.5	86.6	150.8	57.2
	80	145.8	145.8	158.3	117.8	172.7	88.7	141.1	141.1	152.4	115.2	166.3	86.4	136.1	136.1	146.1	112.4	159.5	84.1	130.9	130.9	139.7	109.5	152.4	81.6
	85	153.5	153.5	159.0	141.0	173.1	111.7	148.7	148.7	153.2	138.4	166.8	109.2	143.6	143.6	147.1	135.7	160.1	106.6	138.3	138.3	140.8	132.9	153.2	103.8
	90	161.3	161.3	161.4	161.4	173.9	134.8	156.4	156.4	156.5	156.5	167.5	132.4	151.2	151.2	151.3	151.3	160.9	129.8	145.7	145.7	145.9	145.9	154.0	127.0

Equal MBH and SHC values constitute dry coil condition. Total Gross Cooling Capacity (MBh) shown to the left is not applicable. In this case the Sensible Heat Capacity (SHC) is the total capacity.

All capacities shown are gross and have not considered indoor fan heat.

To obtain net cooling capacities, subtract indoor fan heat.

MBH = Total Gross Cooling Capacity

SHC = Sensible Heat Capacity

Table PD-8: Gross Cooling Capacities (MBh) – 15 Ton TTA180B Condensing Unit with 15 Ton TWE180B Air Handler

CFM Airflow	Enter. DB (° F)	Ambient Temperature																							
		85						95						105						115					
		Entering WB																							
		61		67		73		61		67		73		61		67		73		61		67		73	
MBH	SHC	MBH	SHC	MBH	SHC	MBH	SHC	MBH	SHC	MBH	SHC	MBH	SHC	MBH	SHC	MBH	SHC	MBH	SHC	MBH	SHC	MBH	SHC		
5400	75	168.8	132.7	186.2	112.4	204.7	75.9	162.4	129.4	179.0	109.5	196.7	73.1	155.3	125.8	171.2	106.4	187.9	70.1	147.7	121.9	162.9	103.1	178.5	66.9
	80	169.8	154.7	186.5	127.9	205.2	99.4	163.5	151.4	179.4	124.6	197.4	96.4	156.6	147.9	171.7	121.1	188.9	93.3	149.3	144.2	163.5	117.3	179.9	90.0
	85	173.3	173.3	187.4	149.7	206.0	122.3	167.9	167.9	180.4	146.4	198.2	119.4	162.0	162.0	172.7	142.9	189.8	116.2	155.6	155.6	164.5	139.2	180.9	112.9
	90	182.1	182.1	188.4	171.8	206.3	144.2	176.6	176.6	181.5	168.6	198.6	141.0	170.5	170.5	174.1	165.1	190.3	137.6	164.0	164.0	166.3	161.5	181.5	134.0
6000	75	172.2	138.6	189.6	109.4	207.9	77.2	165.5	135.2	182.1	106.3	199.5	74.3	158.2	131.5	174.1	103.0	190.5	71.2	150.3	127.6	165.5	99.5	180.9	67.9
	80	173.4	162.7	190.0	133.3	208.7	102.7	167.0	159.4	182.7	129.9	200.6	99.7	160.0	155.8	174.8	126.3	191.8	96.5	152.6	152.0	166.3	122.5	182.6	93.1
	85	178.9	178.9	191.0	157.1	209.5	127.6	173.3	173.3	183.6	153.7	201.4	124.6	167.1	167.1	175.7	150.1	192.3	120.6	160.4	160.4	167.3	146.3	183.2	116.9
	90	188.1	188.1	192.4	181.3	209.9	151.0	182.3	182.3	185.4	178.0	202.0	147.8	176.0	176.0	177.9	174.6	193.4	144.3	169.1	169.1	169.3	169.3	184.3	140.6
6600	75	175.0	144.2	192.4	113.0	210.4	78.6	168.1	140.7	184.7	109.8	201.9	75.6	160.6	137.0	176.5	106.5	192.7	72.3	152.5	133.0	167.0	102.0	182.9	68.9
	80	176.7	170.4	193.0	138.4	211.5	105.7	170.1	167.0	185.4	135.0	203.2	102.7	162.3	162.3	177.3	131.3	194.2	99.5	155.6	155.6	168.6	127.4	184.8	96.1
	85	183.8	183.8	193.9	164.1	211.8	131.9	177.9	177.9	186.4	160.7	203.6	128.6	171.5	171.5	178.3	157.1	194.9	125.1	164.5	164.5	169.8	153.2	185.6	121.3
	90	193.3	193.3	196.0	190.4	213.0	157.5	187.3	187.3	188.9	187.1	204.8	154.2	180.6	180.6	180.8	180.8	196.0	150.7	173.5	173.5	173.7	173.7	186.7	147.0
7200	75	177.4	149.5	194.7	116.3	212.6	79.6	170.3	146.0	186.9	113.2	203.9	76.5	162.6	142.2	177.9	108.9	194.5	73.3	154.5	138.2	169.0	104.9	184.5	69.8
	80	179.7	177.7	195.5	143.2	213.9	108.6	172.5	172.5	187.8	139.8	205.4	105.6	166.0	166.0	179.5	136.1	196.3	102.3	159.0	159.0	170.6	132.1	186.6	99.0
	85	188.2	188.2	196.4	170.8	214.4	136.3	182.0	182.0	188.8	167.4	206.0	133.0	175.3	175.3	180.7	163.7	197.1	129.4	168.1	168.1	172.1	159.9	187.6	125.6
	90	198.0	198.0	199.4	199.2	215.7	163.8	191.7	191.7	191.8	191.8	207.1	160.4	184.8	184.8	185.0	185.0	198.2	156.9	177.4	177.4	177.6	177.6	188.8	153.1

Equal MBH and SHC values constitute dry coil condition. Total Gross Cooling Capacity (MBh) shown to the left is not applicable. In this case the Sensible Heat Capacity (SHC) is the total capacity.

All capacities shown are gross and have not considered indoor fan heat.

To obtain net cooling capacities, subtract indoor fan heat.

MBH = Total Gross Cooling Capacity

SHC = Sensible Heat Capacity

PRODUCT DATA

American Standard Inc.

Performance Data

15 Tons

Table PD-9: Gross Cooling Capacities (MBh) – 15 Ton TTA180B Condensing Unit with 20 Ton TWE240B Air Handler

CFM Airflow	Enter. DB (° F)	Ambient Temperature																																															
		85						95						105						115																													
		Entering WB																																															
		61			67			73			61			67			73			61			67			73																							
MBH	SHC	MBH	SHC	MBH	SHC	MBH	SHC	MBH	SHC	MBH	SHC	MBH	SHC	MBH	SHC	MBH	SHC	MBH	SHC	MBH	SHC	MBH	SHC	MBH	SHC	MBH	SHC	MBH	SHC																				
6400	75	179.7	148.2	197.6	124.2	216.0	80.8	172.5	144.6	189.7	121.1	207.2	77.8	164.8	140.8	181.3	117.7	197.6	74.7	156.5	136.6	171.5	112.9	187.5	71.3	181.5	175.1	198.2	142.2	217.5	108.7	174.7	171.7	190.5	138.7	208.9	105.6	166.7	166.7	182.1	134.9	199.8	102.3	159.8	159.8	173.2	130.9	190.1	98.9
	80	188.9	188.9	199.2	168.7	218.4	136.4	182.8	182.8	191.5	165.2	209.5	132.2	176.1	176.1	183.2	161.5	200.5	128.6	169.0	169.0	174.4	157.6	190.9	124.7	198.7	198.7	201.3	195.8	219.0	162.0	192.4	192.4	194.0	192.5	210.7	158.7	185.6	185.6	185.9	185.9	201.7	155.1	178.4	178.4	178.6	178.6	192.2	151.3
	85	181.1	151.2	199.0	117.9	217.3	81.2	173.8	147.6	191.1	114.7	208.5	78.2	166.0	143.7	182.5	111.2	198.9	74.9	157.6	139.5	172.6	106.2	188.6	71.3	183.1	179.3	199.7	144.9	218.9	110.3	176.3	175.8	191.8	141.4	210.3	107.2	168.8	168.8	183.4	137.6	201.0	103.9	161.7	161.7	174.4	133.6	191.2	100.5
	90	191.4	191.4	200.6	172.4	219.9	139.1	185.2	185.2	192.9	169.0	210.9	134.6	178.4	178.4	184.6	165.3	202.3	132.7	171.1	171.1	175.7	161.3	192.5	129.3	203.9	203.9	204.0	204.0	221.9	165.5	195.0	195.0	195.2	195.2	212.1	162.1	188.1	188.1	188.3	188.3	203.0	158.5	180.7	180.7	180.8	180.8	194.5	154.7
7000	75	182.3	154.1	200.3	119.8	218.5	81.9	175.0	150.5	192.3	116.5	209.5	78.7	167.1	146.6	183.6	113.1	199.8	75.4	158.7	142.4	174.3	109.4	189.4	71.8	184.8	183.4	201.0	147.6	220.2	111.9	177.5	177.5	193.1	144.0	211.5	108.8	170.8	170.8	184.5	140.2	202.1	105.5	163.6	163.6	175.4	136.1	192.2	102.1
	80	193.7	193.7	202.0	176.2	221.3	141.7	187.4	187.4	194.2	172.7	212.2	137.0	180.5	180.5	185.8	168.9	203.4	135.4	173.1	173.1	177.0	165.0	193.6	131.9	193.7	193.7	202.0	176.2	221.3	141.7	187.4	187.4	194.2	172.7	212.2	137.0	180.5	180.5	185.8	168.9	203.4	135.4	173.1	173.1	177.0	165.0	193.6	131.9
	85	206.2	206.2	206.4	206.4	223.1	172.3	199.6	199.6	199.8	199.8	214.5	168.9	192.5	192.5	192.5	192.5	204.2	161.9	182.8	182.8	183.0	183.0	194.5	158.1	206.2	206.2	206.4	206.4	223.1	172.3	199.6	199.6	199.8	199.8	214.5	168.9	192.5	192.5	192.5	192.5	204.2	161.9	182.8	182.8	183.0	183.0	194.5	158.1
	90	183.5	157.0	201.5	121.6	219.5	82.4	176.1	153.3	193.3	118.3	210.5	79.2	168.2	149.4	184.6	114.9	200.7	75.9	159.7	145.2	175.2	111.2	190.2	72.3	185.7	185.7	202.2	150.2	221.4	113.5	179.4	179.4	194.2	146.6	212.6	110.4	172.6	172.6	185.6	142.8	203.2	107.1	165.3	165.3	176.4	138.7	193.1	103.6
7300	75	195.9	195.9	203.3	179.8	222.5	144.3	189.5	189.5	195.5	176.3	213.8	141.2	182.5	182.5	187.0	172.6	204.5	138.0	175.0	175.0	178.1	168.6	194.6	134.5	195.9	195.9	203.3	179.8	222.5	144.3	189.5	189.5	195.5	176.3	213.8	141.2	182.5	182.5	187.0	172.6	204.5	138.0	175.0	175.0	178.1	168.6	194.6	134.5
	80	206.2	206.2	206.4	206.4	223.1	172.3	199.6	199.6	199.8	199.8	214.5	168.9	192.5	192.5	192.5	192.5	204.2	161.9	182.8	182.8	183.0	183.0	194.5	158.1	206.2	206.2	206.4	206.4	223.1	172.3	199.6	199.6	199.8	199.8	214.5	168.9	192.5	192.5	192.5	192.5	204.2	161.9	182.8	182.8	183.0	183.0	194.5	158.1
	85	183.5	157.0	201.5	121.6	219.5	82.4	176.1	153.3	193.3	118.3	210.5	79.2	168.2	149.4	184.6	114.9	200.7	75.9	159.7	145.2	175.2	111.2	190.2	72.3	185.7	185.7	202.2	150.2	221.4	113.5	179.4	179.4	194.2	146.6	212.6	110.4	172.6	172.6	185.6	142.8	203.2	107.1	165.3	165.3	176.4	138.7	193.1	103.6
	90	195.9	195.9	203.3	179.8	222.5	144.3	189.5	189.5	195.5	176.3	213.8	141.2	182.5	182.5	187.0	172.6	204.5	138.0	175.0	175.0	178.1	168.6	194.6	134.5	195.9	195.9	203.3	179.8	222.5	144.3	189.5	189.5	195.5	176.3	213.8	141.2	182.5	182.5	187.0	172.6	204.5	138.0	175.0	175.0	178.1	168.6	194.6	134.5

Equal MBH and SHC values constitute dry coil condition. Total Gross Cooling Capacity (MBh) shown to the left is not applicable. In this case the Sensible Heat Capacity (SHC) is the total capacity.

All capacities shown are gross and have not considered indoor fan heat.

To obtain net cooling capacities, subtract indoor fan heat.

MBH = Total Gross Cooling Capacity

SHC = Sensible Heat Capacity

Table PD-10: Gross Cooling Capacities (MBh) – Both Compressors – 15 Ton TTA180C Condensing Unit with 15 Ton TWE180B Air Handler

CFM Airflow	Enter. DB (° F)	Ambient Temperature																																															
		85						95						105						115																													
		Entering WB																																															
		61			67			73			61			67			73			61			67			73																							
MBH	SHC	MBH	SHC	MBH	SHC	MBH	SHC	MBH	SHC	MBH	SHC	MBH	SHC	MBH	SHC	MBH	SHC	MBH	SHC	MBH	SHC	MBH	SHC	MBH	SHC	MBH	SHC	MBH	SHC																				
5400	75	169.2	132.9	186.6	112.6	205.4	76.1	162.7	129.6	179.4	109.7	197.3	73.3	155.6	125.9	171.6	106.6	188.5	70.3	148.0	122.1	163.2	103.2	179.0	67.1	173.6	173.6	187.9	149.9	206.6	122.6	168.2	168.2	180.8	146.6	198.8	119.6	162.3	162.3	173.1	143.1	190.4	116.4	155.9	155.9	164.8	139.3	181.4	113.1
	80	182.5	182.5	188.9	172.0	207.0	144.5	176.9	176.9	182.0	168.8	199.2	141.3	170.9	170.9	174.5	165.3	190.9	137.8	164.3	164.3	166.7	161.7	182.0	134.2	182.5	182.5	188.9	172.0	207.0	144.5	176.9	176.9	182.0	168.8	199.2	141.3	170.9	170.9	174.5	165.3	190.9	137.8	164.3	164.3	166.7	161.7	182.0	134.2
	85	172.5	138.8	190.1	109.6	208.6	77.4	165.8	135.4	182.6	106.5	200.2	74.5	158.5	131.7	174.5	103.2	191.1	71.4	150.6	127.7	165.9	99.6	181.5	68.1	179.2	179.2	191.5	157.3	210.2	127.9	173.6	173.6	184.1	153.9	202.1	124.9	167.4	167.4	176.2	150.3	192.9	120.8	160.7	160.7	167.7	146.5	183.7	117.1
	90	188.5	188.5	192.9	181.5	210.6	151.3	182.7	182.7	185.8	178.2	202.6	148.0	176.3	176.3	178.3	174.8	194.0	144.5	169.4	169.4	169.6	169.6	184.9	140.9	188.5	188.5	192.9	181.5	210.6	151.3	182.7	182.7	185.8	178.2	202.6	148.0	176.3	176.3	178.3	174.8	194.0	144.5	169.4	169.4	169.6	169.6	184.9	140.9
6000	75	175.4	144.4	192.9	113.2	211.2	78.8	168.4	140.9	185.2	110.0	202.6	75.8	160.9	137.2	176.9	106.7	193.3	72.6	152.8	133.1	167.4	102.2	183.4	69.1	177.1	177.1	193.5	138.6	212.2	106.0	170.5	167.2	185.9	135.2	203.9	102.9	162.6	162.6	177.8	131.5	194.9	99.7	155.8	155.8	169.0	127.6	185.3	96.3
	80	188.6	188.6	194.4	164.3	212.5	132.2	178.3	178.3	186.9	160.9	204.3	128.9	171.8	171.8	178.8	157.3	195.5	125.3	164.8	164.8	170.2	153.4	186.1	121.6	188.6	188.6	194.4	164.3	212.5	132.2	178.3	178.3	186.9	160.9	204.3	128.9	171.8	171.8	178.8	157.3	195.5	125.3	164.8	164.8	170.2	153.4	186.1	121.6
	85	193.8	193.8	196.5	190.6	213.7	157.8	187.7	187.7	189.4	187.4	205.5	154.5	181.0	181.0	181.2	181.2	196.6	151.0	173.9	173.9	174.1	174.1	187.3	147.2	193.8	193.8	196.5	190.6	213.7	157.8	187.7	187.7	189.4	187.4	205.5	154.5	181.0	181.0	181.2	181.2	196.6	151.0	173.9	173.9	174.1	174.1	187.3	147.2
	90	177.8	149.7	195.3	116.6	213.3	79.9	170.7	146.2	187.5	113.4	204.6	76.8	163.0	142.4	178.4	109.1	195.1	73.5	154.8	138.3	169.4	105.1	185.1	70.0	180.1	180.1	197.0	143.5	214.6	108.9	172.8	172.8	188.3	140.0	206.1	105.8	166.3	166.3	179.9	136.3	197.0	102.6	159.2	159.2	171.0	132.3	187.2	99.2
7200	75	188.6	188.6	196.0	171.0	215.1	136.6	182.4	182.4	189.4	167.6	206.8	133.2	175.7	175.7	181.2	164.0	197.8	129.7	168.5	168.5	172.5	160.1	188.2	125.8	198.4	198.4	199.9	199.5	216.2	164.0	192.1	192.1	192.3	192.3	207.9	160.7	185.2	185.2	185.4	185.4	198.9	157.2	177.8	177.8	178.0	178.0	189.4	153.4
	80	188.6	188.6	196.0	171.0	215.1	136.6	182.4	182.4	189.4	167.6	206.8	133.2	175.7	175.7	181.2	164.0	197.8	129.7	168.5	168.5	172.5	160.1	188.2	125.8	198.4	198.4	199.9	199.5	216.2	164.0	192.1	192.1	192.3	192.3	207.9</													

Performance Data

15, 20 Tons

Table PD-11: Gross Cooling Capacities (MBh) – One Compressor– 15 Ton TTA180C Condensing Unit with 15 Ton TWE180B Air Handler

CFM Airflow	Enter. DB (° F)	Ambient Temperature																									
		85						95						105						115							
		Entering WB																									
		61			67			73			61			67			73			61			67			73	
MBH	SHC	MBH	SHC	MBH	SHC	MBH	SHC	MBH	SHC	MBH	SHC	MBH	SHC	MBH	SHC	MBH	SHC	MBH	SHC	MBH	SHC	MBH	SHC	MBH	SHC	MBH	SHC
5400	75	106.1	103.0	116.0	75.9	126.9	49.3	102.4	101.3	111.8	74.2	122.1	47.8	98.1	98.1	107.1	72.2	116.9	46.1	94.0	94.0	102.0	70.1	111.3	44.3		
	80	111.6	111.6	116.6	97.9	127.7	70.8	108.1	108.1	112.4	96.2	123.0	69.1	104.3	104.3	107.8	94.3	118.0	67.2	100.1	100.1	102.9	92.2	112.6	65.2		
	85	118.2	118.2	118.3	118.3	128.6	92.8	114.6	114.6	114.7	114.7	123.9	91.1	110.7	110.7	110.8	110.8	118.9	89.2	106.4	106.4	106.5	106.5	113.5	87.2		
90	125.0	125.0	125.1	125.1	129.3	115.1	121.2	121.2	121.4	121.4	121.4	121.4	113.4	117.2	117.2	117.3	117.3	119.8	111.5	112.8	112.8	112.9	112.9	114.5	109.6		
6000	75	107.5	107.5	117.4	80.4	128.0	49.3	104.1	104.1	113.0	78.8	123.1	47.7	100.2	100.2	108.3	77.0	117.9	46.0	96.0	96.0	103.1	73.0	112.1	44.2		
	80	114.2	114.2	118.0	103.0	129.3	74.4	110.6	110.6	113.7	101.3	124.5	72.8	106.7	106.7	109.1	99.3	119.3	71.1	102.3	102.3	104.1	97.2	113.9	69.4		
	85	121.0	121.0	121.2	121.2	130.0	97.5	117.3	117.3	117.4	117.4	125.2	95.7	113.2	113.2	113.3	113.3	120.1	93.8	108.8	108.8	108.9	108.9	114.6	91.8		
90	128.1	128.1	128.2	128.2	130.9	121.8	124.2	124.2	124.4	124.4	126.4	120.1	120.0	120.0	120.1	120.1	121.4	118.2	115.4	115.4	115.5	115.5	115.6	115.6	115.6		
6600	75	109.6	109.6	118.4	83.7	128.9	50.2	106.0	106.0	114.0	80.1	124.0	48.6	102.1	102.1	109.2	78.1	118.6	46.9	97.7	97.7	104.0	75.8	112.8	45.0		
	80	116.4	116.4	119.2	108.0	130.4	77.3	112.7	112.7	114.9	106.2	125.6	75.7	108.7	108.7	110.3	104.2	120.3	74.0	104.3	104.3	105.3	102.1	114.7	72.2		
	85	123.5	123.5	123.6	123.6	131.2	101.9	119.7	119.7	119.8	119.8	126.3	100.1	115.4	115.4	115.5	115.5	121.1	98.2	110.9	110.9	111.0	111.0	115.5	96.1		
90	130.8	130.8	130.9	130.9	132.4	128.3	126.8	126.8	126.9	126.9	126.9	126.9	129.2	129.2	129.3	129.3	122.4	122.5	122.6	122.6	117.7	117.7	117.8	117.8	117.9		
7200	75	111.4	111.4	119.3	84.7	129.7	51.0	107.7	107.7	114.9	82.9	124.6	49.4	103.7	103.7	110.0	80.8	119.2	47.7	99.2	99.2	104.7	78.6	113.2	45.8		
	80	118.4	118.4	120.4	112.7	131.3	80.1	114.6	114.6	116.0	110.9	126.4	78.5	110.5	110.5	111.4	108.9	121.1	76.7	105.9	105.9	105.9	105.9	115.4	74.9		
	85	125.7	125.7	125.8	125.8	132.1	106.2	121.7	121.7	121.8	121.8	127.3	104.4	117.4	117.4	117.5	117.5	122.0	102.5	112.7	112.7	112.8	112.8	116.4	100.4		
90	133.0	133.0	133.2	133.2	133.3	133.3	129.0	129.0	129.2	129.2	129.2	129.3	129.3	124.6	124.6	124.7	124.7	124.8	124.8	119.7	119.7	119.8	119.8	119.9	119.9		

Equal MBH and SHC values constitute dry coil condition. Total Gross Cooling Capacity (MBh) shown to the left is not applicable. In this case the Sensible Heat Capacity (SHC) is the total capacity.

All capacities shown are gross and have not considered indoor fan heat.
To obtain net cooling capacities, subtract indoor fan heat.
MBH = Total Gross Cooling Capacity
SHC = Sensible Heat Capacity

Table PD-12: Gross Cooling Capacities (MBh) – 20 Ton TTA240B Condensing Unit with 20 Ton TWE240B Air Handler

CFM Airflow	Enter. DB (° F)	Ambient Temperature																									
		85						95						105						115							
		Entering WB																									
		61			67			73			61			67			73			61			67			73	
MBH	SHC	MBH	SHC	MBH	SHC	MBH	SHC	MBH	SHC	MBH	SHC	MBH	SHC	MBH	SHC	MBH	SHC	MBH	SHC	MBH	SHC	MBH	SHC	MBH	SHC	MBH	SHC
7200	75	227.7	179.1	251.2	151.2	276.5	102.3	219.2	174.8	241.6	147.3	265.8	98.6	210.0	170.1	231.5	143.2	254.3	94.6	200.3	165.2	220.7	138.9	242.0	90.5		
	80	229.1	208.8	252.2	173.1	277.1	134.0	220.8	204.5	242.1	168.3	266.5	130.0	211.9	200.0	232.1	163.7	255.3	125.8	202.6	195.2	221.5	158.9	243.4	121.4		
	85	233.8	233.8	252.7	202.0	278.0	164.9	226.7	226.7	243.3	197.7	267.5	160.9	219.0	219.0	233.3	193.1	256.4	156.7	210.9	210.9	222.7	188.3	244.6	152.4		
90	245.7	245.7	254.3	231.9	278.3	194.7	238.3	238.3	245.1	227.6	268.0	190.4	230.4	230.4	235.5	223.2	256.9	185.9	222.0	222.0	225.4	218.5	245.2	181.2			
8000	75	232.2	187.1	255.8	147.5	281.0	104.1	223.3	182.7	245.9	143.3	269.8	100.3	213.9	177.9	235.4	139.0	257.9	96.3	203.9	173.0	224.4	134.5	245.2	91.8		
	80	234.1	219.7	256.2	179.9	281.7	138.4	225.6	215.4	246.5	175.5	270.9	134.4	216.6	210.8	236.2	170.8	259.3	130.1	207.1	206.0	225.2	165.9	247.0	125.7		
	85	241.4	241.4	257.4	212.0	282.8	172.0	233.9	233.9	247.7	207.6	272.0	168.0	225.9	225.9	237.4	203.0	260.5	163.8	217.3	217.3	226.6	198.1	247.6	158.2		
90	253.8	253.8	259.7	244.8	283.2	204.0	246.1	246.1	250.4	240.5	272.5	199.7	237.7	237.7	240.6	236.0	261.1	195.1	228.9	228.9	229.1	229.1	249.1	190.2			
8800	75	236.0	194.7	259.5	152.2	284.6	106.1	226.9	190.2	249.4	148.1	273.1	102.0	217.2	185.4	238.6	143.7	260.8	97.7	207.0	180.3	227.3	139.1	247.8	93.1		
	80	238.7	230.2	260.2	186.9	285.6	142.5	230.0	225.8	250.2	182.4	274.5	138.5	219.5	219.5	239.5	177.6	262.6	134.2	210.9	210.9	228.3	172.6	250.0	129.7		
	85	248.0	248.0	261.4	221.5	286.7	178.8	240.2	240.2	251.5	217.1	275.6	174.8	231.8	231.8	241.0	212.4	263.2	169.2	222.8	222.8	230.0	207.5	250.8	164.3		
90	260.9	260.9	264.6	257.2	287.4	212.9	252.8	252.8	255.2	252.9	276.3	208.5	244.1	244.1	244.3	244.3	264.6	203.8	234.8	234.8	235.0	235.0	252.2	198.9			
9600	75	239.3	202.0	262.8	156.8	287.6	107.5	229.9	197.4	252.4	152.6	275.8	103.3	220.0	192.5	241.4	148.2	263.3	98.9	209.7	187.4	228.9	142.3	250.0	94.4		
	80	242.8	240.2	263.6	193.5	288.9	146.5	232.9	232.9	253.3	188.9	277.5	142.4	224.4	224.4	242.4	184.1	265.3	138.1	215.4	215.4	230.9	179.0	252.5	133.6		
	85	253.9	253.9	265.0	230.8	289.3	184.3	245.7	245.7	254.9	226.3	278.1	179.8	237.0	237.0	244.3	221.5	266.1	175.1	227.7	227.7	233.1	216.6	253.5	170.1		
90	267.1	267.1	267.3	267.3	290.9	221.4	258.7	258.7	258.9	258.9	279.6	216.9	249.7	249.7	249.9	249.9	267.6	212.2	240.0	240.0	240.2	240.2	254.9	207.3			

Equal MBH and SHC values constitute dry coil condition. Total Gross Cooling Capacity (MBh) shown to the left is not applicable. In this case the Sensible Heat Capacity (SHC) is the total capacity.

All capacities shown are gross and have not considered indoor fan heat.
To obtain net cooling capacities, subtract indoor fan heat.
MBH = Total Gross Cooling Capacity
SHC = Sensible Heat Capacity

PRODUCT DATA

American Standard Inc.

Performance Data

7 1/2 Tons

Table PD-13: Gross Cooling Capacities (MBh) – 7 1/2 Ton TTA090A Condensing Unit Only

Outdoor Temperature In Degrees F		Suction Temperature Degrees F					
		30	35	40	45	50	55
65	Head press PSIG	166.0	171.0	177.0	182.0	189.0	195.0
	Cap. Btuh/1000	82.0	90.1	98.6	107.3	116.3	125.4
	Unit KW	5.5	5.6	5.7	5.9	6.1	6.3
75	Head press PSIG	190.0	196.0	202.0	208.0	214.0	221.0
	Cap. Btuh/1000	78.4	86.1	94.1	102.3	110.8	119.5
	Unit KW	6.0	6.1	6.3	6.5	6.7	6.9
85	Head press PSIG	217.0	223.0	229.0	236.0	242.0	250.0
	Cap. Btuh/1000	74.4	81.7	89.2	97.1	105.2	113.5
	Unit KW	6.6	6.8	6.9	7.1	7.3	7.5
95	Head press PSIG	247.0	253.0	259.0	266.0	273.0	281.0
	Cap. Btuh/1000	70.1	77.0	84.2	91.6	99.3	107.3
	Unit KW	7.4	7.5	7.7	7.9	8.1	8.3
105	Head press PSIG	279.0	285.0	292.0	299.0	307.0	315.0
	Cap. Btuh/1000	65.4	72.0	78.8	85.9	93.3	100.9
	Unit KW	8.2	8.4	8.6	8.8	9.0	9.2
115	Head press PSIG	313.0	320.0	327.0	335.0	343.0	351.0
	Cap. Btuh/1000	60.50	66.70	73.20	80.00	87.00	94.30
	Unit KW	9.17	9.35	9.54	9.73	9.92	10.12

Performance data calculated at 15° F subcooling and 20% superheat and does not include capacity loss due to refrigerant lines.

Table PD-14: Capacity Curves – 7 1/2 Ton TTA090A Condensing Unit Only

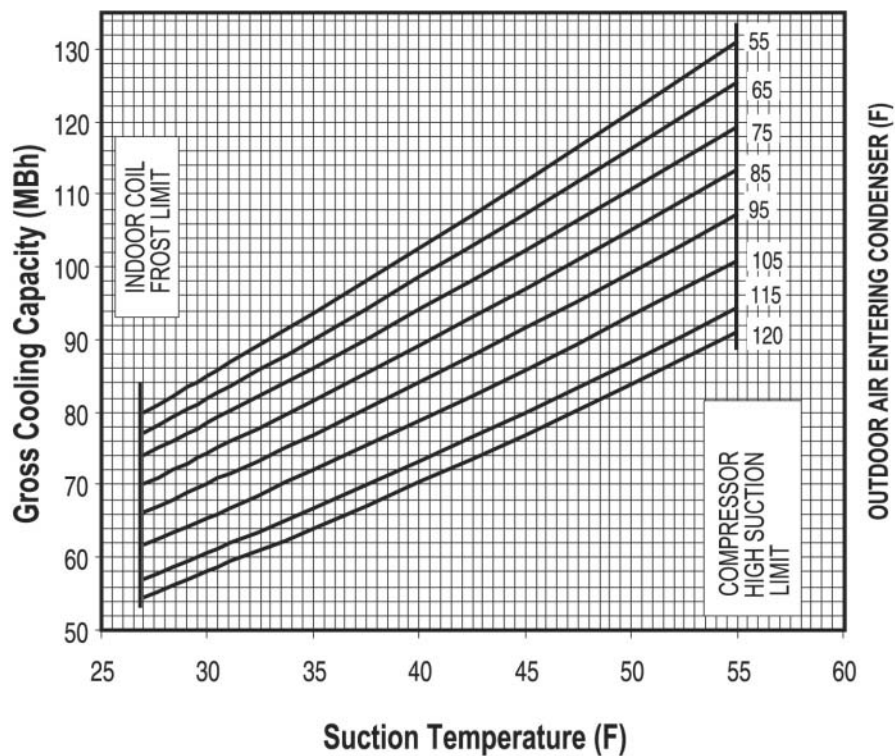

Performance Data

10 Ton

Table PD-15: Gross Cooling Capacities (MBh) – 10 Ton TTA120A Condensing Unit Only

Outdoor Temperature In Degrees F		Suction Temperature Degrees F					
		30	35	40	45	50	55
65	Head press PSIG	172.0	178.0	185.0	192.0	201.0	209.0
	Cap. Btuh/1000	112.5	123.7	135.5	147.9	160.9	174.6
	Unit KW	8.0	8.2	8.4	8.7	8.9	9.2
75	Head press PSIG	196.0	203.0	210.0	218.0	226.0	235.0
	Cap. Btuh/1000	107.5	118.2	129.4	141.3	153.9	167.0
	Unit KW	8.7	8.9	9.1	9.4	9.7	10.0
85	Head press PSIG	223.0	230.0	237.0	245.0	254.0	263.0
	Cap. Btuh/1000	102.2	112.3	123.1	134.6	146.6	159.2
	Unit KW	9.5	9.7	10.0	10.3	10.6	10.9
95	Head press PSIG	252.0	260.0	267.0	276.0	285.0	294.0
	Cap. Btuh/1000	96.5	106.3	116.6	127.5	139.1	151.2
	Unit KW	10.4	10.7	11.0	11.3	11.6	11.9
105	Head press PSIG	285.0	292.0	300.0	309.0	318.0	328.0
	Cap. Btuh/1000	90.6	99.9	109.8	120.3	131.4	142.9
	Unit KW	11.5	11.8	12.0	12.4	12.7	13.0
115	Head press PSIG	319.0	327.0	336.0	345.0	355.0	365.0
	Cap. Btuh/1000	84.50	93.40	102.90	112.90	123.40	134.40
	Unit KW	12.64	12.94	13.25	13.58	13.91	14.26

Performance data calculated at 15° F subcooling and 20% superheat and does not include capacity loss due to refrigerant lines.

Table PD-16: Capacity Curves – 10 Ton TTA120A Condensing Unit Only

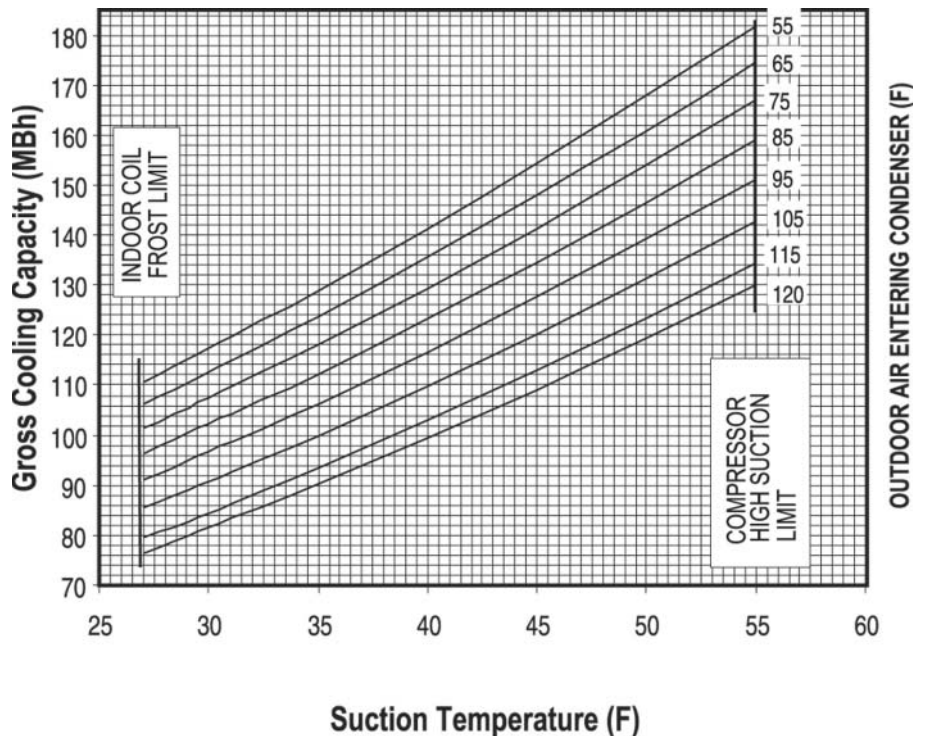

Performance Data

10 Ton

Table PD-17: Gross Cooling Capacities (MBh) – Both Compressors Operating – 10 Ton TTA120C Condensing Unit Only

Outdoor Temperature In Degrees F		Suction Temperature Degrees F					
		30	35	40	45	50	55
65	Head press PSIG	173.2	179.0	185.4	192.2	199.7	207.5
	Cap. Btuh/1000	110.8	121.1	132.0	143.7	156.0	168.9
	Unit KW	7.9	8.2	8.4	8.7	9.0	9.3
75	Head press PSIG	197.4	203.7	210.5	217.8	225.6	233.9
	Cap. Btuh/1000	105.7	116.0	126.9	138.4	150.5	163.0
	Unit KW	8.6	8.8	9.1	9.4	9.7	10.0
85	Head press PSIG	224.4	231.1	238.3	246.1	254.2	262.8
	Cap. Btuh/1000	100.6	110.7	121.4	132.6	144.3	156.3
	Unit KW	9.3	9.6	9.9	10.2	10.5	10.8
95	Head press PSIG	254.4	261.4	268.9	276.9	285.3	294.1
	Cap. Btuh/1000	95.6	105.3	115.6	126.3	137.3	148.7
	Unit KW	10.2	10.5	10.8	11.1	11.4	11.7
105	Head press PSIG	287.3	294.5	302.2	310.3	318.8	327.7
	Cap. Btuh/1000	90.7	99.8	109.4	119.5	129.7	140.3
	Unit KW	11.2	11.4	11.7	12.1	12.4	12.7
115	Head press PSIG	323.2	330.6	338.3	346.3	354.8	363.6
	Cap. Btuh/1000	85.70	94.20	103.00	112.20	121.60	131.20
	Unit KW	12.20	12.50	12.80	13.20	13.50	13.80

Performance data calculated at 15° F subcooling and 20% superheat and does not include capacity loss due to refrigerant lines.

Table PD-18: Capacity Curves – Both Compressors Operating – 10 Ton TTA120C Condensing Unit Only

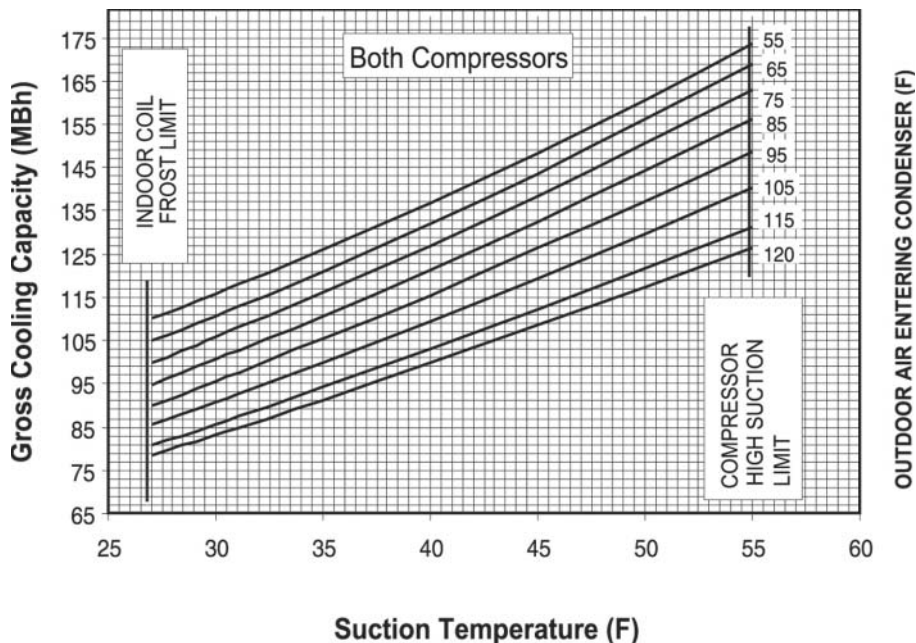

Performance Data

10 Ton

Table PD-19: Gross Cooling Capacities (MBh) – One Compressor Operating – 10 Ton TTA120C Condensing Unit Only

Outdoor Temperature In Degrees F		Suction Temperature Degrees F					
		30	35	40	45	50	55
65	Head press PSIG	140.8	143.2	145.7	148.4	151.2	154.2
	Cap. Btuh/1000	59.0	64.1	69.5	75.1	81.1	87.4
	Unit KW	4.1	4.2	4.3	4.4	4.5	4.6
75	Head press PSIG	163.6	166.3	169.2	172.3	175.5	178.9
	Cap. Btuh/1000	56.3	61.6	67.2	73.2	79.4	86.1
	Unit KW	4.4	4.4	4.5	4.6	4.7	4.8
85	Head press PSIG	188.9	192.0	195.2	198.6	202.2	205.9
	Cap. Btuh/1000	53.6	59.0	64.7	70.7	77.2	83.9
	Unit KW	4.7	4.8	4.8	4.9	5.0	5.1
95	Head press PSIG	217.0	220.3	223.8	227.5	231.3	235.3
	Cap. Btuh/1000	50.9	56.2	61.9	67.9	74.3	81.0
	Unit KW	5.1	5.1	5.2	5.3	5.4	5.5
105	Head press PSIG	248.0	251.5	255.3	259.2	263.2	267.5
	Cap. Btuh/1000	48.3	53.4	58.9	64.8	71.0	77.4
	Unit KW	5.5	5.6	5.7	5.8	5.8	5.9
115	Head press PSIG	282.0	285.7	289.6	293.6	297.9	302.3
	Cap. Btuh/1000	45.70	50.50	55.80	61.30	67.20	73.30
	Unit KW	6.00	6.10	6.20	6.30	6.30	6.40

Performance data calculated at 15° F subcooling and 20% superheat and does not include capacity loss due to refrigerant lines.

Table PD-20: Capacities Curves – One Compressor Operating – 10 Ton TTA120C Condensing Unit Only

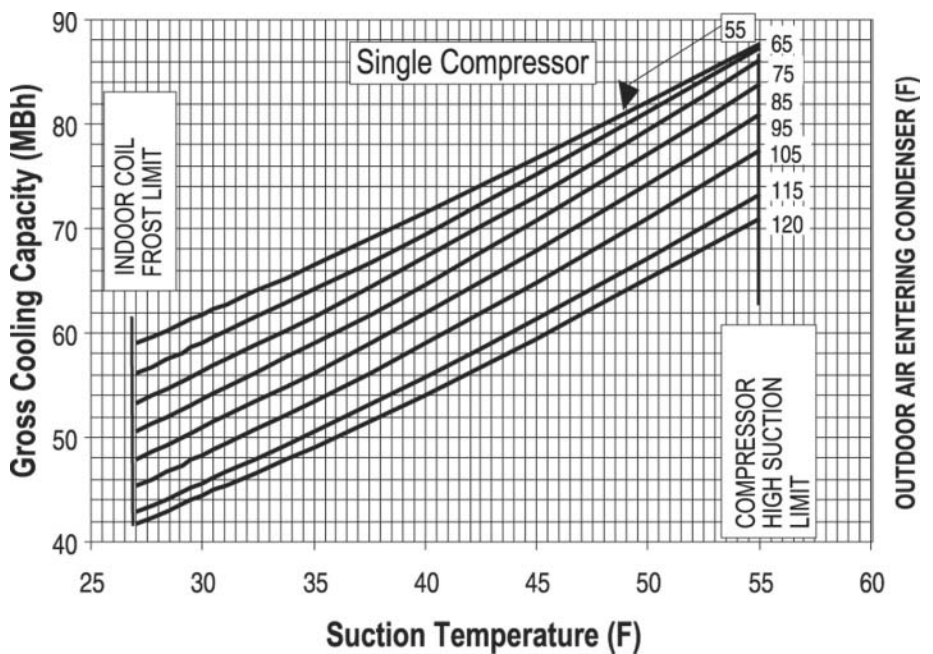

Performance Data

10 Ton

Table PD-21: Gross Cooling Capacities (MBh) – 10 Ton TTA120B Condensing Unit Only

Outdoor Temperature In Degrees F		Suction Temperature Degrees F					
		30	35	40	45	50	55
65	Head pressure PSIG	162.0	167.0	172.0	178.0	184.0	190.0
	Capacity BTUH/1000	110.2	120.3	130.9	142.3	154.4	167.3
	Unit KW	7.7	7.9	8.2	8.4	8.7	9.0
75	Head pressure PSIG	188.0	193.0	199.0	205.0	212.0	219.0
	Capacity BTUH/1000	105.1	115.3	126.1	137.6	149.8	162.7
	Unit KW	8.4	8.6	8.9	9.1	9.4	9.7
85	Head pressure PSIG	215.0	221.0	228.0	235.0	242.0	250.0
	Capacity BTUH/1000	100.1	110.2	120.8	132.2	144.2	156.9
	Unit KW	9.2	9.5	9.7	10.0	10.3	10.6
95	Head pressure PSIG	246.0	252.0	259.0	267.0	274.0	283.0
	Capacity BTUH/1000	95.1	104.9	115.2	126.2	137.7	149.8
	Unit KW	10.1	10.4	10.7	10.9	11.3	11.6
105	Head pressure PSIG	279.0	286.0	293.0	301.0	309.0	318.0
	Capacity BTUH/1000	90.2	99.4	109.2	119.6	130.4	141.8
	Unit KW	11.1	11.4	11.7	12.0	12.3	12.7
115	Head pressure PSIG	316.0	323.0	330.0	338.0	346.0	355.0
	Capacity BTUH/1000	85.20	93.80	102.90	112.50	122.50	133.00
	Unit KW	12.24	12.53	12.85	13.17	13.49	13.82

Performance data calculated at 15° F subcooling and 20% superheat and does not include capacity loss due to refrigerant lines.

Table PD-22: Capacity Curves – 10 Ton TTA120B Condensing Unit Only

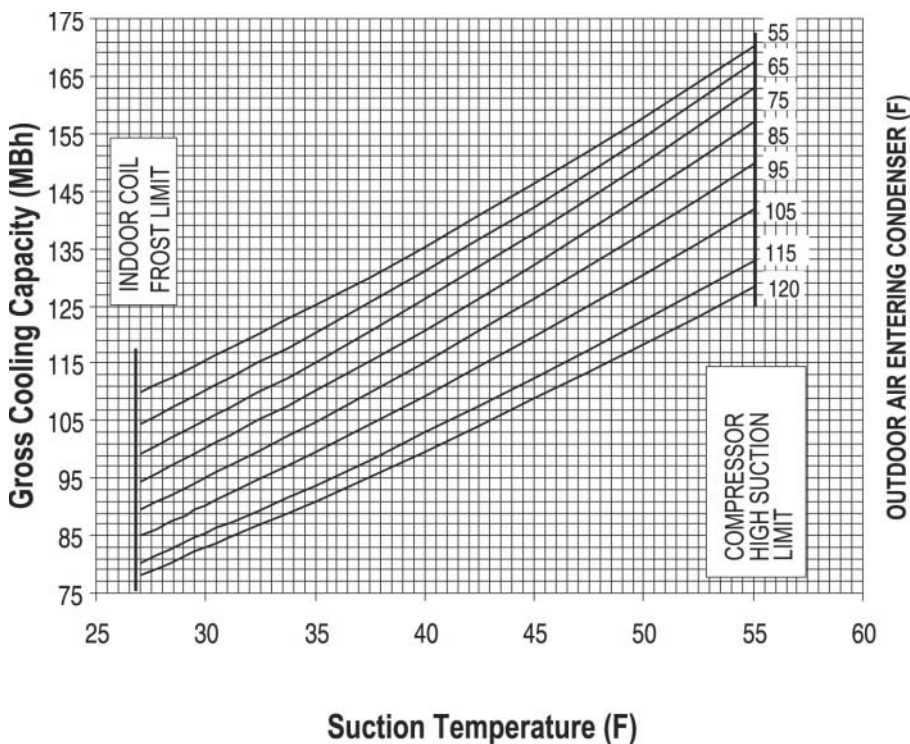

Performance Data

12 1/2 Ton

Table PD-23: Gross Cooling Capacities (MBh) – 12 1/2 Ton TTA150B Condensing Unit Only

Outdoor Temperature		Suction Temperature Degrees F					
In Degrees F		30	35	40	45	50	55
65	Head pressure PSIG	178.0	184.0	190.0	197.0	203.0	210.0
	Capacity BTUH/1000	133.1	145.5	158.5	171.9	185.7	199.8
	Unit KW	9.2	9.5	9.8	10.1	10.5	10.8
75	Head pressure PSIG	205.0	211.0	218.0	224.0	231.0	239.0
	Capacity BTUH/1000	126.9	138.8	151.1	164.0	177.2	190.9
	Unit KW	10.2	10.4	10.8	11.1	11.4	11.8
85	Head pressure PSIG	234.0	241.0	248.0	255.0	262.0	270.0
	Capacity BTUH/1000	120.4	131.8	143.7	156.0	168.7	181.8
	Unit KW	11.2	11.5	11.9	12.2	12.5	12.9
95	Head pressure PSIG	266.0	273.0	281.0	288.0	296.0	305.0
	Capacity BTUH/1000	113.6	124.6	136.0	147.8	160.0	172.6
	Unit KW	12.4	12.8	13.1	13.4	13.8	14.2
105	Head pressure PSIG	301.0	308.0	316.0	324.0	333.0	342.0
	Capacity BTUH/1000	106.6	117.1	128.0	139.3	151.1	163.2
	Unit KW	13.8	14.1	14.4	14.8	15.2	15.6
115	Head pressure PSIG	338.0	346.0	354.0	363.0	372.0	381.0
	Capacity BTUH/1000	99.40	109.40	119.80	130.70	142.00	153.70
	Unit KW	15.23	15.56	15.92	16.29	16.68	17.10

Performance data calculated at 15° F subcooling and 20% superheat and does not include capacity loss due to refrigerant lines.

Table PD-24: Capacity Curves – 12 1/2 Ton TTA150B Condensing Unit Only

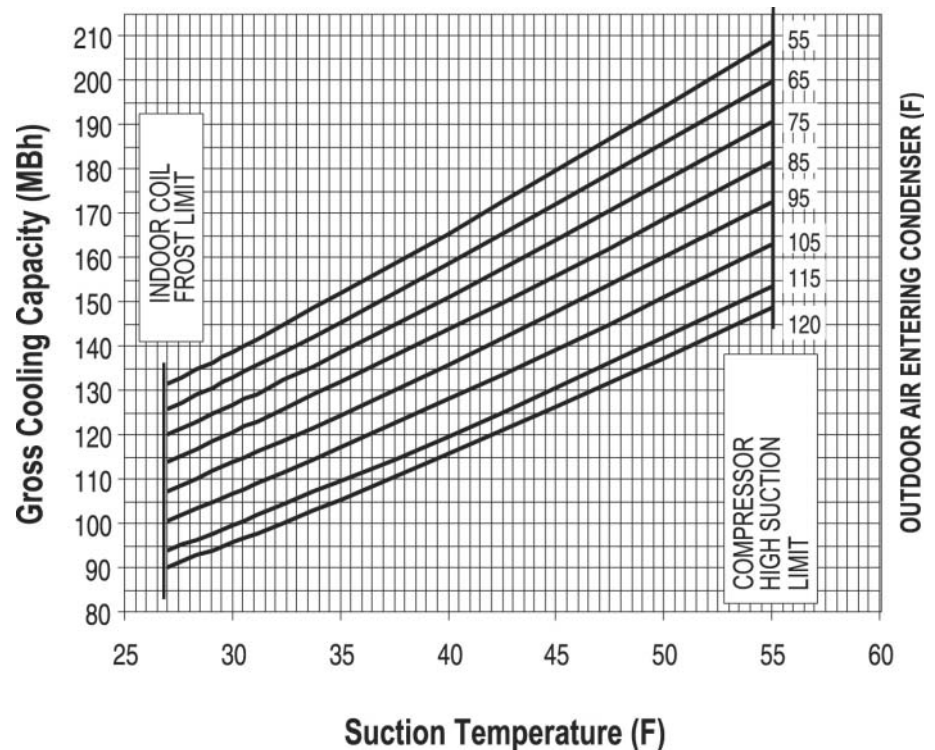

Performance Data

15 Ton

Table PD-25: Gross Cooling Capacities (MBh) – 15 Ton TTA180B Condensing Unit Only

Outdoor Temperature		Suction Temperature Degrees F					
In Degrees F		30	35	40	45	50	55
65	Head pressure PSIG	179.0	186.0	194.0	202.0	210.0	220.0
	Capacity BTUH/1000	163.9	179.7	196.2	213.3	231.2	249.9
	Unit KW	11.3	11.6	12.0	12.5	12.9	13.4
75	Head pressure PSIG	204.0	211.0	219.0	227.0	236.0	246.0
	Capacity BTUH/1000	156.4	171.5	187.2	203.6	220.9	239.0
	Unit KW	12.3	12.7	13.1	13.6	14.1	14.6
85	Head pressure PSIG	231.0	239.0	247.0	255.0	265.0	275.0
	Capacity BTUH/1000	148.2	162.7	177.7	193.4	210.0	227.4
	Unit KW	13.6	14.0	14.5	14.9	15.5	16.0
95	Head pressure PSIG	261.0	269.0	277.0	286.0	296.0	306.0
	Capacity BTUH/1000	139.6	153.3	167.6	182.6	198.5	215.2
	Unit KW	15.1	15.5	16.0	16.4	17.0	17.5
105	Head pressure PSIG	293.0	301.0	310.0	319.0	329.0	340.0
	Capacity BTUH/1000	130.5	143.5	157.1	171.3	186.5	202.5
	Unit KW	16.8	17.2	17.6	18.1	18.6	19.2
115	Head pressure PSIG	328.0	336.0	345.0	355.0	365.0	377.0
	Capacity BTUH/1000	121.00	133.20	146.10	159.60	174.10	189.30
	Unit KW	18.62	19.03	19.47	19.92	20.42	20.94

Performance data calculated at 15° F subcooling and 20% superheat and does not include capacity loss due to refrigerant lines.

Table PD-26: Capacity Curves – 15 Ton TTA180B Condensing Unit Only

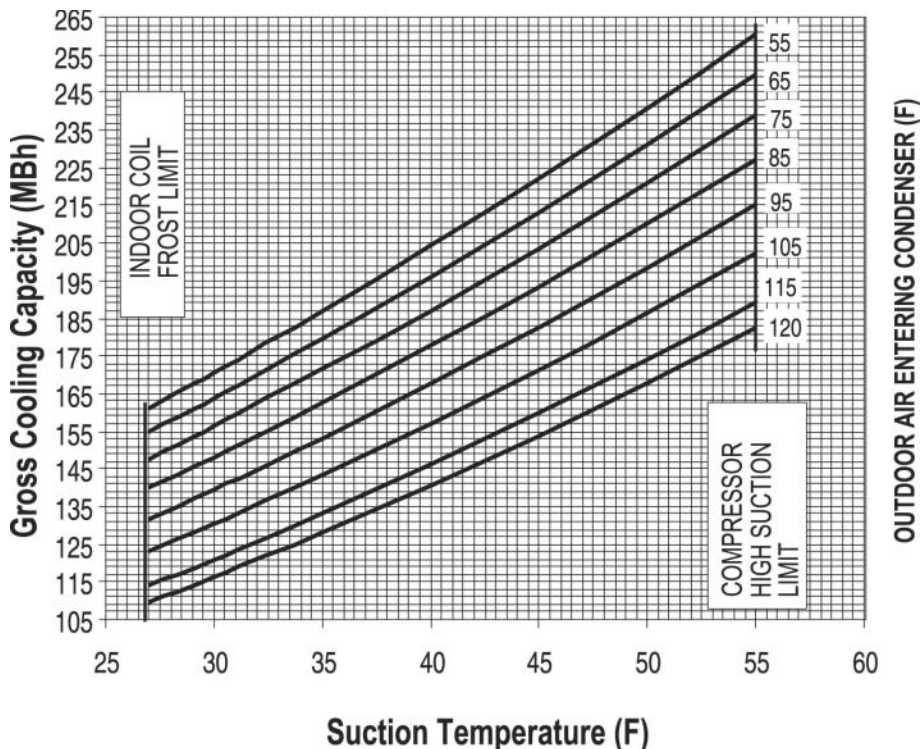

Performance Data

15 Ton

Table PD-27: Gross Cooling Capacities (MBh) – Both Compressors Operating – 15 Ton TTA180C Condensing Unit Only

Outdoor Temperature In Degrees F		Suction Temperature Degrees F					
		30	35	40	45	50	55
65	Head press PSIG	177.5	184.3	191.6	199.3	207.8	217.0
	Cap. Btuh/1000	163.9	179.7	196.1	213.3	231.2	250.0
	Unit KW	11.2	11.5	11.9	12.3	12.8	13.3
75	Head press PSIG	202.2	209.3	216.8	225.1	234.0	243.6
	Cap. Btuh/1000	156.3	171.4	187.1	203.7	221.0	239.1
	Unit KW	12.3	12.6	13.0	13.5	14.0	14.5
85	Head press PSIG	229.4	236.7	244.7	253.4	262.7	272.7
	Cap. Btuh/1000	148.1	162.5	177.6	193.6	210.2	227.5
	Unit KW	13.5	13.9	14.4	14.8	15.3	15.9
95	Head press PSIG	259.2	266.8	275.2	284.2	293.9	304.3
	Cap. Btuh/1000	139.5	153.2	167.6	182.8	198.7	215.3
	Unit KW	15.0	15.4	15.9	16.4	16.9	17.4
105	Head press PSIG	291.5	299.4	308.1	317.6	327.6	338.3
	Cap. Btuh/1000	130.3	143.3	157.0	171.5	186.7	202.5
	Unit KW	16.7	17.1	17.5	18.0	18.5	19.1
115	Head press PSIG	326.3	334.5	343.6	353.4	363.8	374.8
	Cap. Btuh/1000	120.80	133.00	145.90	159.70	174.20	189.30
	Unit KW	18.50	18.90	19.40	19.90	20.30	20.80

Performance data calculated at 15° F subcooling and 20% superheat and does not include capacity loss due to refrigerant lines.

Table PD-28: Capacity Curves – Both Compressors Operating – 15 Ton TTA180C Condensing Unit Only

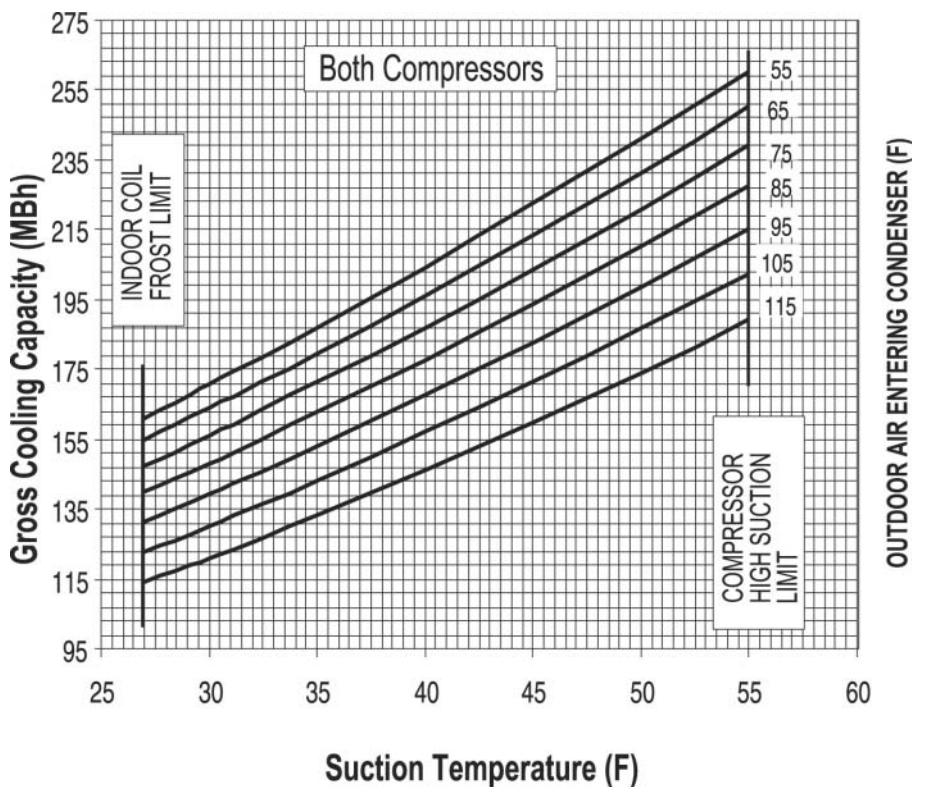

Performance Data

15 Ton

Table PD-29: Gross Cooling Capacities (MBh) – One Compressor Operating – 15 Ton TTA180C Condensing Unit Only

Outdoor Temperature		Suction Temperature Degrees F					
In Degrees F		30	35	40	45	50	55
65	Head press PSIG	143.5	146.7	150.1	153.8	157.6	161.7
	Cap. Btuh/1000	83.0	91.5	100.4	109.9	119.8	130.2
	Unit KW	5.5	5.6	5.7	5.8	5.9	6.0
75	Head press PSIG	166.9	170.4	174.0	177.9	181.9	186.2
	Cap. Btuh/1000	80.0	88.2	96.9	106.0	115.6	125.7
	Unit KW	5.9	6.0	6.1	6.2	6.4	6.5
85	Head press PSIG	192.8	196.4	200.3	204.3	208.6	213.0
	Cap. Btuh/1000	76.4	84.4	92.8	101.6	110.9	120.6
	Unit KW	6.4	6.5	6.7	6.8	6.9	7.1
95	Head press PSIG	221.2	225.1	229.1	233.4	237.9	242.7
	Cap. Btuh/1000	72.5	80.2	88.2	96.7	105.7	115.1
	Unit KW	7.1	7.2	7.3	7.5	7.6	7.8
105	Head press PSIG	252.3	256.5	260.7	265.3	270.1	275.1
	Cap. Btuh/1000	68.2	75.5	83.3	91.5	100.1	109.2
	Unit KW	7.8	8.0	8.1	8.2	8.4	8.5
115	Head press PSIG	286.2	290.6	295.1	299.9	304.9	310.2
	Cap. Btuh/1000	63.70	70.60	78.00	85.90	94.20	102.90
	Unit KW	8.70	8.80	9.00	9.10	9.20	9.40

Performance data calculated at 15° F subcooling and 20% superheat and does not include capacity loss due to refrigerant lines.

Table PD-30: Capacity Curves – One Compressor Operating – 15 Ton TTA180C Condensing Unit Only

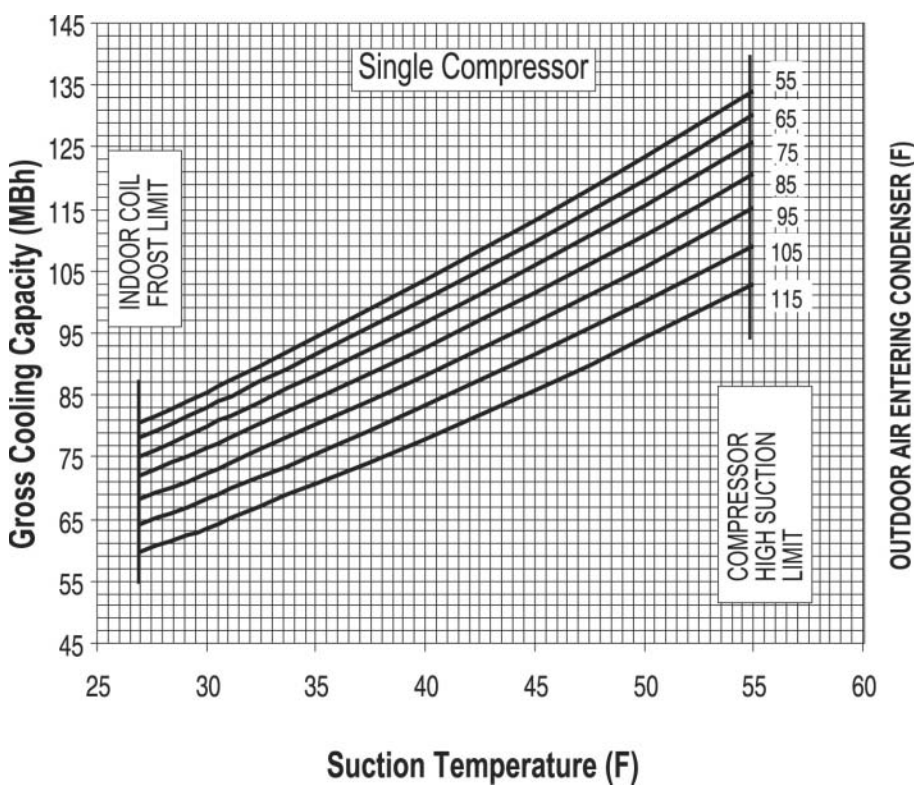

Performance Data

20 Ton

Table PD-31: Gross Cooling Capacities (MBh) – 20 Ton TTA240B Condensing Unit Only

Outdoor Temperature		Suction Temperature Degrees F					
In Degrees F		30	35	40	45	50	55
65	Head pressure PSIG	172.0	178.0	185.0	191.0	198.0	206.0
	Capacity BTUH/1000	221.1	242.4	264.7	288.2	312.7	338.2
	Unit KW	15.31	15.7	16.13	16.59	17.08	17.6
75	Head pressure PSIG	198.0	204.0	211.0	218.0	226.0	234.0
	Capacity BTUH/1000	210.9	231.1	252.4	274.8	298.2	322.7
	Unit KW	16.77	17.21	17.68	18.2	18.73	19.3
85	Head pressure PSIG	226.0	233.0	240.0	248.0	256.0	264.0
	Capacity BTUH/1000	200.0	219.2	239.5	260.9	283.2	306.5
	Unit KW	18.5	18.99	19.5	20.05	20.63	21.23
95	Head pressure PSIG	257.0	264.0	272.0	280.0	288.0	297.0
	Capacity BTUH/1000	188.4	206.7	226.1	246.4	267.6	289.6
	Unit KW	20.5	21.03	21.59	22.17	22.78	23.41
105	Head pressure PSIG	290.0	298.0	306.0	314.0	323.0	332.0
	Capacity BTUH/1000	176.4	193.8	212.2	231.5	251.5	272.3
	Unit KW	22.77	23.33	23.92	24.53	25.16	25.81
115	Head pressure PSIG	326.0	334.0	343.0	351.0	361.0	370.0
	Capacity BTUH/1000	164.0	180.5	198.0	216.2	235.0	254.5
	Unit KW	25.28	25.88	26.50	27.13	27.77	28.42

Performance data calculated at 15° F subcooling and 20% superheat and does not include capacity loss due to refrigerant lines.

Table PD-32: Capacity Curves – 20 Ton TTA240B Condensing Unit Only

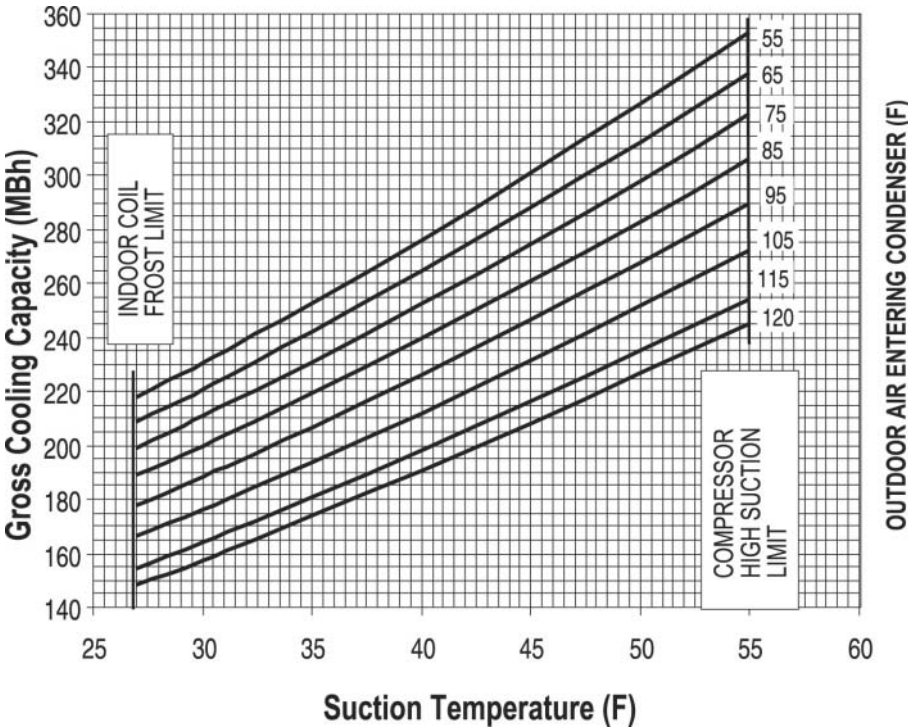

PRODUCT DATA

American Standard Inc.

Performance Data 5 Ton

Table PD-33: Evaporator Fan Performance 5 Ton TWE060A, TWE060B – Air Handler

External Static Pressure (Inches of Water Gauge)																																																																																																																																																																																																																																
		.10"		.20"		.30"		.40"		.50"		.60"		.70"		.80"		.90"		1.00"		1.10"		1.20"																																																																																																																																																																																																								
CFM	RPM	BHP	RPM	BHP	RPM	BHP	RPM	BHP	RPM	BHP	RPM	BHP	RPM	BHP	RPM	BHP	RPM	BHP	RPM	BHP	RPM	BHP	RPM	BHP	RPM	BHP																																																																																																																																																																																																						
.75 HP Standard Motor and Field Supplied Low Static Drive										.75 HP Standard Motor and Sheaves																																																																																																																																																																																																																						
1600	578	0.34	625	0.38	676	0.43	727	0.48	778	0.52	828	0.57	879	0.62	930	0.67	963	0.70	995	0.74	1028	0.77	1060	0.8	1700	601	0.35	648	0.4	696	0.44	744	0.49	792	0.54	841	0.59	889	0.64	937	0.69	971	0.73	1005	0.77	1039	0.81	1073	0.84	1800	625	0.36	671	0.41	716	0.46	762	0.51	807	0.56	853	0.61	898	0.66	944	0.71	979	0.76	1015	0.8	1050	0.84	1085	0.88	1900	642	0.4	687	0.45	731	0.5	776	0.55	820	0.6	865	0.66	909	0.71	951	0.75	987	0.80	1023	0.84	1059	0.89	1095	0.93	2000	659	0.44	703	0.49	746	0.54	790	0.6	833	0.65	877	0.7	920	0.75	957	0.8	994	0.84	1031	0.89	1069	0.93	1106	0.98	2100	674	0.48	722	0.54	770	0.6	817	0.65	857	0.7	897	0.75	936	0.8	973	0.85	1009	0.89	1046	0.94	1082	0.99	1119	1.04	2200	689	0.52	741	0.59	793	0.65	845	0.71	881	0.76	917	0.8	953	0.85	989	0.9	1024	0.95	1060	1	1096	1.04	—	—	2300	710	0.57	761	0.63	812	0.7	863	0.76	897	0.81	932	0.86	966	0.91	1001	0.96	1035	1	—	—	—	—	—	—	2400	730	0.61	780	0.68	830	0.75	880	0.82	913	0.87	946	0.91	979	0.96	1013	1.01	—	—	—	—	—	—	—	—
										1 HP Oversized Motor and Sheaves																																																																																																																																																																																																																						

Note:

1 Field Supplied Low Static Drive (use Table PD-34)

Data includes pressure drop due to wet coil and 1" filter.

Fan motor heat (MBh) = 3.15 x BHP.

American Standard's factory supplied motors, in commercial equipment, are definite purpose motors, specifically designed and tested to operate reliably and continuously at all cataloged conditions. Using the full horsepower range of our fan motors as shown in our tabular data will not result in nuisance tripping or premature motor failure. Our product's warranty will not be affected.

Table PD-34: Low Static Fan Drive 5 Ton TWE060A, TWE060B Air Handler¹

Motor Sheave Turns Open	Nominal RPM
0	752
1	708
2	663
3	619
4	574
5	530

Note:

1 Field supplied components required:

Blower Sheave: Fixed Pitch (7.8 inch Pitch Diameter),

Blower Sheave: 0.625 inch Bore, Single Groove, "A" Belt.

Belt: A48

Performance Data

7 1/2 Ton

Table PD-35: Evaporator Fan Performance 7 1/2 Ton TWE090A, TWE090B – Air Handler

External Static Pressure (Inches of Water Gauge)																					
		.10"		.20"		.30"		.40"		.50"		.60"		.70"		.80"		.90"		1.00"	
CFM	RPM	BHP	RPM	BHP	RPM	BHP	RPM	BHP	RPM	BHP	RPM	BHP	RPM	BHP	RPM	BHP	RPM	BHP	RPM	BHP	
1.5 HP Standard Motor and Field Supplied Low Static Drive ¹				1.5 HP Standard Motor and Low Static Drive Kit												1.5 HP Standard Motor and Sheaves					
2400	429	0.45	475	0.51	522	0.58	569	0.65	615	0.71	662	0.78	708	0.84	755	0.91	783	0.98	811	1.05	
2550	453	0.48	496	0.55	539	0.61	582	0.68	626	0.74	669	0.81	712	0.87	756	0.94	785	1	814	1.08	
2700	476	0.52	516	0.58	556	0.65	596	0.71	636	0.77	676	0.83	716	0.9	758	0.96	787	1.02	816	1.11	
2850	500	0.55	537	0.62	573	0.68	610	0.74	646	0.8	683	0.86	720	0.92	759	0.99	788	1.05	819	1.14	
3000	524	0.59	557	0.65	590	0.71	624	0.77	657	0.83	690	0.89	723	0.95	760	1.01	790	1.07	821	1.17	
3150	546	0.62	577	0.68	609	0.75	640	0.81	672	0.87	703	0.94	735	1.00	768	1.07	798	1.15	829	1.25	
3300	568	0.65	598	0.72	628	0.79	657	0.85	687	0.92	717	0.99	746	1.05	776	1.12	807	1.22	837	1.33	
3450	589	0.67	618	0.75	647	0.83	676	0.91	705	0.99	733	1.07	762	1.15	791	1.23	820	1.33	849	1.42	
3600	611	0.69	639	0.79	666	0.88	694	0.97	722	1.06	750	1.16	778	1.25	806	1.34	834	1.43	862	1.51	

Note:

1 Field Supplied Low Static Drive (use Table PD-37)

Data includes pressure drop due to wet coil and 1" filter.

Fan motor heat (MBh) = 3.15 x BHP.

American Standard's factory supplied motors, in commercial equipment, are definite purpose motors, specifically designed and tested to operate reliably and continuously at all cataloged conditions. Using the full horsepower range of our fan motors as shown in our tabular data will not result in nuisance tripping or premature motor failure. Our product's warranty will not be affected.

Table PD-35: (Continued)

External Static Pressure (Inches of Water Gauge)																	
		1.10"		1.20"		1.30"		1.40"		1.50"		1.60"		1.70"		1.80"	
CFM	RPM	BHP	RPM	BHP	RPM	BHP	RPM	BHP	RPM	BHP	RPM	BHP	RPM	BHP	RPM	BHP	
1.5 HP Standard Motor and Sheaves																	
2400	840	1.11	868	1.18	896	1.25	924	1.32	952	1.39	980	1.46	1009	1.52	1037	1.59	
2550	843	1.15	872	1.23	901	1.31	930	1.38	959	1.46	988	1.54	1016	1.61	1045	1.69	
2700	846	1.19	876	1.28	905	1.36	935	1.45	965	1.53	995	1.62	1024	1.7	1054	1.79	
2850	849	1.23	880	1.33	910	1.42	941	1.51	971	1.6	1002	1.7	1032	1.79	1063	1.88	
3000	853	1.27	884	1.37	915	1.48	946	1.58	978	1.68	1009	1.78	1040	1.88	1071	1.98	
3150	860	1.35	891	1.45	922	1.56	958	1.66	984	1.76	1014	1.86	1044	1.94	—	—	
3300	868	1.43	898	1.54	929	1.64	959	1.74	990	1.85	1020	1.95	1049	2.01	—	—	
3450	879	1.52	908	1.61	937	1.71	966	1.8	995	1.9	1025	2.00	—	—	—	—	
3600	890	1.6	918	1.69	945	1.78	973	1.87	1001	1.96	—	—	—	—	—	—	
2 HP Oversized Motor and Sheaves																	

Table PD-36: Low Static Fan Drive 7 1/2 Ton TWE090A,B Air Handler¹

Motor Sheave Turns Open	Nominal RPM
0	598
1	563
2	528
3	493
4	458
5	422

Table PD-37: Low Static Fan Drive Kit 7 1/2 Ton TWE090A,B Air Handler

Motor Sheave Turns Open	Nominal RPM
0	733
1	690
2	647
3	604
4	561
5	518

Note:

1 Field supplied components required:

Blower Sheave: Fixed Pitch (9.8 inch Pitch Diameter),

Blower Sheave: 1.00 inch Bore, Single Groove, "A" Belt.

Belt: A55

PRODUCT DATA

American Standard Inc.

Performance Data 10 Ton

Table PD-38: Evaporator Fan Performance 10 Ton TWE120A1, TWE120B1 – Air Handler

CFM	External Static Pressure (Inches of Water Gauge)																										
	.10"		.20"		.30"		.40"		.50"		.60"		.70"		.80"		.90"		1.00"		1.20"		1.40"		1.60"		
RPM	BHP	RPM	BHP	RPM	BHP	RPM	BHP	RPM	BHP	RPM	BHP	RPM	BHP	RPM	BHP	RPM	BHP	RPM	BHP	RPM	BHP	RPM	BHP	RPM	BHP	RPM	BHP
2 HP Standard Motor and Field Supplied Low Static Drive ¹												2 HP Standard Motor and Sheaves															
3200	—	—	—	—	570	0.67	603	0.75	636	0.83	670	0.91	703	1.00	736	1.08	756	1.14	784	1.2	838	1.32	890	1.49	942	1.66	
3400	—	—	560	0.71	592	0.79	623	0.88	652	0.95	685	1.04	716	1.12	743	1.18	762	1.24	790	1.3	844	1.43	895	1.59	948	1.8	
3600	557	0.77	583	0.84	613	0.92	643	1.01	667	1.07	700	1.16	730	1.23	750	1.27	768	1.34	797	1.41	850	1.55	900	1.69	954	1.94	
3800	579	0.94	605	1.01	634	1.09	663	1.18	683	1.24	710	1.29	738	1.37	762	1.42	785	1.49	813	1.56	861	1.72	911	1.87	—	—	
4000	602	1.11	628	1.17	656	1.26	683	1.35	698	1.4	720	1.43	747	1.5	773	1.58	801	1.64	829	1.71	872	1.89	922	2.04	—	—	
4200	626	1.23	651	1.31	677	1.4	703	1.48	714	1.53	741	1.59	765	1.66	790	1.72	815	1.81	841	1.9	888	2.08	—	—	—	—	
4400	649	1.36	674	1.45	698	1.53	723	1.62	729	1.65	761	1.76	784	1.81	807	1.87	830	1.98	852	2.09	—	—	—	—	—	—	
4600	669	1.52	692	1.62	714	1.69	735	1.77	747	1.82	782	1.92	798	1.99	815	2.06	—	—	—	—	—	—	—	—	—	—	
4800	689	1.69	711	1.79	729	1.85	746	1.92	764	1.98	802	2.09	—	—	—	—	—	—	—	—	—	—	—	—	—	—	

Note:

1 Field Supplied Low Static Drive (use Table PD-39)
Data includes pressure drop due to wet coil and 1" filter.
Fan motor heat (MBh) = 3.15 x BHP.

American Standard's factory supplied motors, in commercial equipment, are definite purpose motors, specifically designed and tested to operate reliably and continuously at all cataloged conditions. Using the full horsepower range of our fan motors as shown in our tabular data will not result in nuisance tripping or premature motor failure. Our product's warranty will not be affected.

Table PD-39: Low Static Fan Drive 10 Ton TWE120A1,B1 Air Handler¹

Motor Sheave Turns Open	Nominal RPM
0	745
1	706
2	666
3	627
4	588
5	549

Note:

1 Field supplied components required:
Blower Sheave: Fixed Pitch (8.8 inch Pitch Diameter),
Blower Sheave: 1.00 inch Bore, Single Groove, "A" Belt.
Belt: A54

Performance Data

10 Ton

Table PD-40: Evaporator Fan Performance 10 Ton TWE120A3, AW; TWE120B3, BW – Air Handler

External Static Pressure (Inches of Water Gauge)																																																																																																																																																																																																														
CFM	.10"			.20"			.30"			.40"			.50"			.60"			.70"			.80"			.90"			1.00"			1.20"																																																																																																																																																																															
	RPM	BHP	RPM	BHP	RPM	BHP	RPM	BHP	RPM	BHP	RPM	BHP	RPM	BHP	RPM	BHP	RPM	BHP	RPM	BHP	RPM	BHP	RPM	BHP	RPM	BHP	RPM	BHP	RPM	BHP																																																																																																																																																																																
										2 HP Standard Motor and Field Supplied Low Static Drive ¹										2 HP Standard Motor and Sheaves																																																																																																																																																																																										
3200	—	—	—	—	570	0.67	603	0.75	636	0.83	670	0.91	703	1.00	736	1.08	756	1.14	784	1.2	838	1.32	3400	—	—	560	0.71	592	0.79	623	0.88	652	0.95	685	1.04	716	1.12	743	1.18	762	1.24	790	1.3	844	1.43	3600	557	0.77	583	0.84	613	0.92	643	1.01	667	1.07	700	1.16	730	1.23	750	1.27	768	1.34	797	1.41	850	1.55	3800	579	0.94	605	1.01	634	1.09	663	1.18	683	1.24	710	1.29	738	1.37	762	1.42	785	1.49	813	1.56	861	1.72	4000	602	1.11	628	1.17	656	1.26	683	1.35	698	1.40	720	1.43	747	1.5	773	1.58	801	1.64	829	1.71	872	1.89	4200	626	1.23	651	1.31	677	1.4	703	1.48	714	1.53	741	1.59	765	1.66	790	1.72	815	1.81	841	1.9	888	2.08	4400	649	1.36	674	1.45	698	1.53	723	1.62	729	1.65	761	1.76	784	1.81	807	1.87	830	1.98	852	2.09	904	2.27	4700	669	1.52	792	1.62	714	1.69	735	1.77	747	1.82	782	1.92	798	1.99	815	2.06	837	2.18	862	2.29	922	2.45	4800	689	1.69	711	1.79	729	1.85	746	1.92	764	1.98	802	2.09	812	2.17	822	2.24	844	2.39	872	2.48	939	2.64
										3 HP Oversized Motor and Sheaves																																																																																																																																																																																																				

Note:

1 Field Supplied Low Static Drive (use Table PD-41)

Data includes pressure drop due to wet coil and 1" filter.

Fan motor heat (MBh) = 3.15 x BHP.

American Standard's factory supplied motors, in commercial equipment, are definite purpose motors, specifically designed and tested to operate reliably and continuously at all cataloged conditions. Using the full horsepower range of our fan motors as shown in our tabular data will not result in nuisance tripping or premature motor failure. Our product's warranty will not be affected.

Table PD-40: (Continued)

External Static Pressure (Inches of Water Gauge)																																																																																																																				
CFM	1.40"		1.60"		1.80"		2.00"		2.20"		2.40"																																																																																																									
	RPM	BHP	RPM	BHP	RPM	BHP	RPM	BHP	RPM	BHP	RPM	BHP																																																																																																								
2 HP Standard Motor and Sheaves						3 HP Oversized Motor and Sheaves																																																																																																														
3200	890	1.49	942	1.66	1001	1.84	1051	2.03	1106	2.24	1162	2.44	3400	895	1.59	948	1.80	1009	1.98	1057	2.17	1111	2.37	1165	2.57	3600	900	1.69	954	1.94	1016	2.13	1065	2.31	1115	2.51	1167	2.7	3800	911	1.87	959	2.15	1024	2.35	1070	2.54	1120	2.73	1169	2.92	4000	922	2.04	965	2.36	1031	2.57	1077	2.76	1124	2.95	—	—	4200	941	2.29	984	2.54	1039	2.73	1083	2.91	1129	3.10	—	—	4400	960	2.53	1003	2.71	1047	2.89	1090	3.06	—	—	—	—	4600	979	2.67	1020	2.86	1061	3.06	—	—	—	—	—	—	4800	997	2.8	1036	3.02	—	—	—	—	—	—	—	—

Table PD-41: Low Static Fan Drive 10 Ton TWE120A3,AW; BE,BW Air Handler¹

Motor Sheave Turns Open	Nominal RPM
0	745
1	706
2	666
3	627
4	588
5	549

Note:

1 Field supplied components required:

Blower Sheave: Fixed Pitch (8.8 inch Pitch Diameter),

Blower Sheave: 1.00 inch Bore, Single Groove, "A" Belt.

Belt: A54

PRODUCT DATA

American Standard Inc.

Performance Data 15 Ton

Table PD-42: Evaporator Fan Performance 15 Ton TWE180B – Air Handler

		External Static Pressure (Inches of Water Gauge)																									
		.10"		.20"		.30"		.40"		.50"		.60"		.70"		.80"		.90"		1.00"		1.20"					
CFM	RPM	BHP	RPM	BHP	RPM	BHP	RPM	BHP	RPM	BHP	RPM	BHP	RPM	BHP	RPM	BHP	RPM	BHP	RPM	BHP	RPM	BHP	RPM	BHP			
2 HP Standard Motor and Field Supplied Low Static Drive ¹																3 HP Standard Motor and Sheaves						5 HP Oversized Motor and Sheaves					
4500	637	1.4	662	1.44	687	1.49	701	1.53	717	1.58	732	1.63	747	1.64	754	1.65	782	1.67	817	1.76	873	1.96					
4800	642	1.42	667	1.51	692	1.54	706	1.63	722	1.64	737	1.65	752	1.66	767	1.68	795	1.73	831	1.82	887	2.02					
5100	647	1.45	672	1.52	697	1.57	713	1.66	726	1.68	740	1.70	761	1.72	783	1.77	811	1.85	843	1.96	900	2.19					
5400	652	1.47	677	1.54	702	1.6	719	1.69	730	1.72	742	1.75	769	1.78	798	1.87	827	1.98	856	2.09	914	2.37					
5700	653	1.48	679	1.56	706	1.67	725	1.75	741	1.80	758	1.84	786	1.92	815	2.02	843	2.14	872	2.27	932	2.57					
6000	655	1.49	681	1.59	709	1.74	731	1.8	752	1.87	774	1.94	803	2.05	831	2.17	860	2.29	889	2.44	950	2.78					
6300	658	1.51	687	1.63	716	1.79	741	1.89	765	1.98	792	2.09	823	2.22	853	2.35	883	2.49	913	2.64	974	2.96					
6600	663	1.54	693	1.68	723	1.84	750	1.97	778	2.09	811	2.24	843	2.39	875	2.53	906	2.69	936	2.84	997	3.15					
6900	670	1.62	700	1.77	735	1.98	767	2.15	799	2.29	832	2.44	865	2.61	900	2.79	934	2.98	967	3.16	1019	3.48					
7200	677	1.7	707	1.86	747	2.12	785	2.33	819	2.49	853	2.65	888	2.83	926	3.05	963	3.27	997	3.49	1041	3.81					

Note:

1 Field Supplied Low Static Drive (use Table PD-43)

Data includes pressure drop due to wet coil and 2" filter.

Fan motor heat (MBh) = 3.15 x BHP.

American Standard's factory supplied motors, in commercial equipment, are definite purpose motors, specifically designed and tested to operate reliably and continuously at all cataloged conditions. Using the full horsepower range of our fan motors as shown in our tabular data will not result in nuisance tripping or premature motor failure. Our product's warranty will not be affected.

Table PD-42: (Continued)

		External Static Pressure (Inches of Water Gauge)											
		1.40"		1.60"		1.80"		2.00"		2.20"		2.40"	
CFM	RPM	BHP	RPM	BHP	RPM	BHP	RPM	BHP	RPM	BHP	RPM	BHP	
		3 HP Standard Motor and Sheaves		5 HP Oversized Motor and Sheaves									
4500	929	2.19	986	2.46	1035	2.74	1084	3.01	1132	3.28	—	—	
4800	943	2.29	999	2.56	1046	2.83	1095	3.11	1143	3.38	—	—	
5100	957	2.48	1012	2.76	1058	3.04	1105	3.31	1152	3.57	—	—	
5400	972	2.67	1024	2.96	1070	3.24	1116	3.51	—	—	—	—	
5700	990	2.89	1038	3.18	1083	3.46	1127	3.74	—	—	—	—	
6000	1008	3.11	1052	3.39	1096	3.68	1138	3.96	—	—	—	—	
6300	1025	3.3	1069	3.61	1113	3.92	1152	4.21	—	—	—	—	
6600	1042	3.49	1087	3.83	1130	4.16	—	—	—	—	—	—	
6900	1063	3.81	1107	4.15	1146	4.49	—	—	—	—	—	—	
7200	1085	4.14	1127	4.47	—	—	—	—	—	—	—	—	

Table PD-43: Low Static Fan Drive 15 Ton TWE180B Air Handler¹

Motor Sheave Turns Open	Nominal RPM
0	776
1	748
2	720
3	692
4	663
5	635
6	607

Note:

1 Field supplied components required:
Motor Sheave: Variable Pitch (4.3-5.5 inch Pitch Diameter),
0.875 inch Bore, Single Groove, "B" Belt.

Blower Sheave: Fixed Pitch (12.4 inch Pitch Diameter),
1.4375 inch Bore, Single Groove, "B" Belt.

Belt: B67

Performance Data

20 Ton

Table PD-44: Evaporator Fan Performance 20 Ton TWE240B – Air Handler

CFM	External Static Pressure (Inches of Water Gauge)																					
	.10"		.20"		.30"		.40"		.50"		.60"		.70"		.80"		.90"		1.00"		1.20"	
	RPM	BHP	RPM	BHP	RPM	BHP	RPM	BHP	RPM	BHP	RPM	BHP	RPM	BHP	RPM	BHP	RPM	BHP	RPM	BHP	RPM	BHP
										5 HP Standard Motor and Field Supplied Low Static Drive ¹												
										5 HP Standard Motor and Low Static Drive Kit												
6400	—	—	—	—	570	1.41	612	1.57	654	1.7	696	1.83	743	2.06	781	2.25	808	2.4	835	2.55	883	2.86
6800	—	—	—	—	593	1.58	635	1.74	677	1.90	722	2.08	762	2.29	794	2.46	820	2.61	846	2.76	894	3.07
7200	—	—	573	1.58	615	1.75	657	1.92	700	2.09	747	2.33	781	2.52	806	2.66	831	2.81	856	2.96	904	3.29
7600	—	—	603	1.84	651	1.98	694	2.15	731	2.38	766	2.57	795	2.74	819	2.88	844	3.02	869	3.17	919	3.55
8000	585	1.97	633	2.11	686	2.21	730	2.39	761	2.66	785	2.81	809	2.95	832	3.09	857	3.23	882	3.37	933	3.8
8400	619	2.2	657	2.35	710	2.54	752	2.73	778	2.94	801	3.09	823	3.23	848	3.39	873	3.55	899	3.71	947	4.14
8800	652	2.43	680	2.60	733	2.86	773	3.07	794	3.22	816	3.36	837	3.50	863	3.68	889	3.86	915	4.04	960	4.47
9200	682	2.76	723	2.98	760	3.19	790	3.37	811	3.52	834	3.68	858	3.84	884	4.01	909	4.2	932	4.4	975	4.83
9600	711	3.08	766	3.36	787	3.52	807	3.67	828	3.82	852	3.99	878	4.17	904	4.35	929	4.53	949	4.75	990	5.2
										5 HP Standard Motor and Sheaves												
										7.5 HP Oversized Motor and Sheaves												

Note:

1 Field Supplied Low Static Drive (use Table PD-46)

Data includes pressure drop due to wet coil and 2" filter.

Fan motor heat (MBh) = 3.15 x BHP.

American Standard's factory supplied motors, in commercial equipment, are definite purpose motors, specifically designed and tested to operate reliably and continuously at all cataloged conditions. Using the full horsepower range of our fan motors as shown in our tabular data will not result in nuisance tripping or premature motor failure. Our product's warranty will not be affected.

Table PD-44: (Continued)

CFM	External Static Pressure (Inches of Water Gauge)																			
	1.40"		1.60"		1.80"		2.00"		2.20"		2.40"		2.60"							
	RPM	BHP	RPM	BHP	RPM	BHP	RPM	BHP	RPM	BHP	RPM	BHP	RPM	BHP						
							5 HP Standard Motor and Sheaves							7.5 HP Oversized Motor and Sheaves						
6400	930	3.16	976	3.52	1021	3.89	1066	4.26	1111	4.62	1156	4.99	1201	5.36						
6800	941	3.4	986	3.78	1030	4.16	1075	4.55	1119	4.93	1164	5.31	—	—						
7200	951	3.65	995	4.04	1039	4.44	1083	4.84	1127	5.23	1171	5.63	—	—						
7600	963	3.94	1007	4.34	1050	4.75	1093	5.16	1136	5.57	1179	5.98	—	—						
8000	975	4.23	1018	4.65	1060	5.07	1103	5.49	1145	5.91	1187	6.34	—	—						
8400	989	4.57	1032	5.01	1074	5.44	1117	5.87	1159	6.31	1200	6.73	—	—						
8800	1002	4.92	1045	5.36	1087	5.81	1130	6.26	1172	6.70	—	—	—	—						
9200	1016	5.28	1058	5.73	1099	6.17	1141	6.62	1182	7.07	—	—	—	—						
9600	1030	5.65	1071	6.09	1111	6.54	1152	6.99	1192	7.43	—	—	—	—						

Table PD-45: Low Static Fan Drive Kit 20 Ton TWE240B Air Handler

Motor Sheave Turns Open	Nominal RPM
0	857
1	831
2	805
3	779
4	753
5	727
6	701

Table PD-46: Low Static Fan Drive 20 Ton TWE240B Air Handler¹

Motor Sheave Turns Open	Nominal RPM
0	712
1	686
2	660
3	634
4	609
5	583
6	557

Note:

1 Field supplied components required:

Motor Sheave: Variable Pitch (4.3-5.5 inch Pitch Diameter), 1.125 inch Bore, Single Groove, "B" Belt.

Blower Sheave: Fixed Pitch (13.4 inch Pitch Diameter), 1.4375 inch Bore, Single Groove, "B" Belt.

Belt: B67

Performance Data

5 - 20 Ton

Table PD-47: Standard Motor and Sheave/Fan Speed (RPM) – Air Handler

Tons	Unit Model No.	Sheave Position						
		6 Turns Open	5 Turns Open	4 Turns Open	3 Turns Open	2 Turns Open	1 Turns Open	Closed
5	TWE060A1	—	714	773	833	892	952	1011
	TWE060B							
7 1/2	TWE090A ³	—	726	787	847	908	968	1029
	TWE090B ³							
10	TWE120A1, B1 ²	—	702	760	819	877	936	994
	TWE120A3, AW ³	—	710	761	812	863	913	964
	TWE120B3, BW ³							
15	TWE180B ³	760	795	831	866	902	937	—
20	TWE240B ⁴	862	894	926	958	990	1022	1054

Notes:

- 1 Factory setting is 3.0 turns open.
- 2 Factory setting is 4.0 turns open.
- 3 Factory setting is 4.5 turns open.
- 4 Factory setting is 6.0 turns open.

Table PD-48: Oversized Motor and Sheave/Fan Speed (RPM) – Air Handler

Tons	Unit Model No.	Sheave Position						
		6 Turns Open	5 Turns Open	4 Turns Open	3 Turns Open	2 Turns Open	1 Turns Open	Closed
5	TWE060A1	—	828	897	966	1035	1104	1173
	TWE060B							
	TWE060A3, A4, AW TWE060B3, B4	—	863	934	1006	1078	1150	1222
7 1/2	TWE090A1	—	845	915	986	1056	1127	1197
	TWE090A3, AW	—	847	908	968	1029	1089	1150
10	TWE120A1, B1	—	878	941	1004	1066	1129	1192
	TWE120A3, AW1	—	915	969	1023	1077	1131	1185
	TWE120B3, BW1							
	TWE120A3, AW2 TWE120B3, BW2	—	733	776	819	863	906	949
15	TWE180B	946	981	1016	1052	1087	1122	1157
20	TWE240B	—	991	1040	1091	1140	1190	1239

Notes:

- 1 High Static Motor with 6 1/2" Fan Sheave.
- 2 High Static Motor with 8' Fan Sheave.

Performance Data

5 - 20 Ton

Table PD-49: Electric Heat Discharge Plenum and Grille Airflow (CFM)

Tons	Unit Model No.	Electric Heater Model No.	Airflow (CFM)	
			Minimum	Maximum
5	TWE060A1, B1	BAYHTRL117A	2000	2400
	TWE060A3, B3	BAYHTRL315A	2000	2400
	TWE060A4, B4	BAYHTRL415A	2000	2400
7 1/2	TWE090A1, B1	BAYHTRL117A	3000	3600
	TWE090A3, B3	BAYHTRL123A	3375	3600
		BAYHTRL315A	2625	3600
	TWE090A3, B3	BAYHTRL325A	3000	3600
		BAYHTRL415A	2625	3600
10	TWE120A1, B1	BAYHTRL117A	3500	4800
	TWE120A3, B3	BAYHTRL123A	4000	4800
		BAYHTRL315A	4000	4800
	TWE120A3, B3 ¹	BAYHTRL325A	3500	4800
		BAYHTRL415A	3500	4800
15	TWE180B3	BAYHTRM330A	5250	7200
	TWE180B4	BAYHTRM430A	5250	7200
20	TWE240B3	BAYHTRM330A	7000	9600
	TWE240B4	BAYHTRM430A	7000	9600

Notes:

1 When wired for 460 Volt.

Table PD-50: Discharge Plenum and Grille Assembly Throw Distance (ft) – Air Handler

Unit Tons	Model No.	CFM	Louver Angle Deflection Position				
			Straight	20°	40°	55°	
5	TWE060A	1600	42	31	26	20	
		1800	46	37	29	22	
		2000	48	43	33	24	
		2200	51	50	36	25	
		2400	54	57	39	29	
	TWE090A	2400	52	43	35	29	
		TWE090B	2700	55	48	38	31
			3000	58	53	42	32
			3300	62	57	46	35
			3600	66	60	50	37
TWE120A	3200	56	46	38	30		
	TWE120B	3600	62	51	42	33	
		4000	66	57	47	35	
		4400	71	62	52	38	
		4800	76	67	56	42	
15	TWE180B	4900	47	38	32	25	
		5400	52	44	37	29	
		6000	57	49	41	32	
		6600	61	53	43	34	
		7200	65	57	46	35	
20	TWE240B	6400	56	46	38	30	
		7200	62	51	42	33	
		8000	66	57	47	35	
		8800	71	62	52	38	
		9600	76	67	56	42	

Throw distance values are based on a terminal velocity of 75 FPM.

Throw distance values at other terminal velocities may be established by multiplying throw distances in the table above by throw factor:

Terminal Velocity		Throw Factor
50 FPM	x	1.50
100 FPM	x	.75
150 FPM	x	.50

PRODUCT DATA

American Standard Inc.

Performance Data 5 - 20 Ton

Table PD-51: Static Pressure Drop Through Accessories (inches of water column)¹ – Air Handlers

Tons	Unit Model No.	CFM	Return Grille	Discharge Plenum and Grille ²	Electric Heaters (kW)				Hydronic Coils	
					5-10	15-20	25-30	35-50	Steam	Hot Water
5		1600	0.12	0.21	0.08	0.08	0.14	—	.44	.31
	TWE060A	2000	0.18	0.33	0.13	0.13	0.19	—	.62	.44
	TWE060B	2400	0.28	0.47	0.19	0.19	0.37	—	.80	.59
7½		2400	0.08	0.27	0.03	0.06	0.08	0.12	.38	.23
	TWE090A	3000	0.13	0.4	0.06	0.12	0.17	0.23	.50	.33
	TWE090B	3600	0.18	0.58	0.08	0.16	0.24	0.32	.66	.44
10		3200	0.07	0.43	0.06	0.13	0.19	0.26	.42	.40
	TWE120A	4000	0.11	0.66	0.10	0.20	0.30	0.40	.59	.56
	TWE120B	4800	0.15	0.95	0.14	0.28	0.42	0.57	.76	.75
15		4800	0.09	0.23	0.03	0.03	0.06	0.08	.46	.38
	TWE180B	6000	0.15	0.34	0.06	0.06	0.12	0.17	.64	.54
		7200	0.2	0.49	0.08	0.08	0.16	0.24	.82	.72
20		6400	0.11	0.43	0.06	0.06	0.13	0.19	.50	.41
	TWE240B	8000	0.17	0.66	0.10	0.10	0.20	0.30	.70	.58
		9600	0.23	0.95	0.14	0.14	0.28	0.42	.89	.78

Notes:

1 Return air filter ESP included in Fan Performance Table data.

2 At louver opening angle of 42 degrees. For ESP at other angle openings, see accessory Installer's Guide.

Table PD-52: Auxiliary Electric Heat Capacity – Air Handler

Unit Model No.	Total kW	No. of Stages	Stage 1		Stage 2		Total	
			KW Input	BTUH Output	KW Input	BTUH Output	KW Input	BTUH Output
	5.00	1	5.00	17,065	—	—	5.00	17,065
TWE060A3, A4, AW	9.96	1	9.96	33,993	—	—	9.96	33,993
TWE060B3, B4	14.96	1	14.96	51,058	—	—	14.96	51,058
	24.92	2	14.96	51,058	9.96	33,993	24.92	85,051
	5.00	1	5.00	17,065	—	—	5.00	17,065
TWE090,120A3,AW	9.96	1	9.96	33,993	—	—	9.96	33,993
TWE090B3	14.96	1	14.96	51,058	—	—	14.96	51,058
TWE120B3, BW	24.92	2	14.96	51,058	9.96	33,993	24.92	85,051
TWE060,090,120A1	5.76	1	5.76	19,659	—	—	5.76	19,659
TWE060B1	11.52	1	11.52	39,318	—	—	11.52	39,318
TWE090B1	17.28	1	17.28	58,977	—	—	17.28	58,977
TWE120B1	23.04	2	11.52	39,318	11.52	39,318	23.04	78,636
TWE090,120A1	28.8	2	17.28	58,977	11.52	39,318	28.8	98,295
TWE120B1								
TWE090,120A3, AW	34.88	2	19.92	67,987	14.96	51,058	34.88	119,045
TWE120B3, BW	10.00	1	10.00	34,130	—	—	10.00	34,130
	19.92	1	19.92	67,987	—	—	19.92	67,987
TWE180, 240B	29.92	2	19.92	67,987	10.00	34,130	29.92	102,117
	49.84	2	29.92	102,117	19.92	67,987	49.84	170,104

Heaters are rated at 240V, 480V and 600V. For other than rated voltage, capacity $\left(\frac{\text{Voltage}}{\text{Rated Voltage}}\right)^2 \times \text{Rated Capacity}$.

Performance Data

5 - 20 Ton

Table PD-53: Steam Heating Coil Capacity – Air Handlers Steam Pressure (PSIG)

Tons	Unit Model No.	Airflow (CFM)	Entering Air Temp. (F)	2 PSI			5 PSI			10 PSI			15 PSI			25 PSI		
				LAT ¹	MBh ²	Cond. Lb/Hr ³	LAT ¹	MBh ²	Cond. Lb/Hr ³	LAT ¹	MBh ²	Cond. Lb/Hr ³	LAT ¹	MBh ²	Cond. Lb/Hr ³	LAT ¹	MBh ²	Cond. Lb/Hr ³
5.00	TWE060A TWE060B	1600	40	97.00	99.00	103.00	100.00	104.00	108.00	104.00	111.00	117.00	108.00	117.00	124.00	113.00	127.00	136.00
			60	111.00	88.00	91.00	114.00	93.00	97.00	118.00	100.00	105.00	121.00	106.00	112.00	127.00	116.00	124.00
			80	125.00	77.00	80.00	127.00	82.00	85.00	131.00	89.00	94.00	135.00	95.00	101.00	140.00	105.00	112.00
		2000	40	90.00	108.00	112.00	93.00	114.00	118.00	96.00	122.00	128.00	99.00	129.00	136.00	104.00	139.00	149.00
			60	104.00	96.00	100.00	107.00	102.00	106.00	111.00	110.00	115.00	114.00	116.00	123.00	119.00	127.00	136.00
			80	119.00	84.00	87.00	121.00	90.00	93.00	125.00	98.00	102.00	128.00	104.00	110.00	133.00	115.00	123.00
	2400	40	85.00	116.00	120.00	87.00	123.00	127.00	90.00	131.00	137.00	93.00	138.00	146.00	98.00	150.00	160.00	
		60	100.00	104.00	107.00	102.00	110.00	114.00	105.00	118.00	124.00	108.00	125.00	132.00	113.00	137.00	146.00	
		80	115.00	91.00	94.00	117.00	97.00	100.00	120.00	105.00	110.00	123.00	112.00	118.00	127.00	123.00	132.00	
7½	TWE090A TWE090B	2400	40	102.00	162.00	168.00	106.00	171.00	177.00	110.00	182.00	191.00	114.00	192.00	203.00	120.00	208.00	222.00
			60	115.00	144.00	149.00	119.00	152.00	158.00	123.00	164.00	172.00	127.00	174.00	184.00	133.00	190.00	203.00
			80	129.00	126.00	130.00	132.00	134.00	140.00	136.00	146.00	153.00	140.00	155.00	164.00	146.00	171.00	183.00
		3000	40	95.00	178.00	183.00	97.00	187.00	194.00	101.00	200.00	209.00	105.00	210.00	222.00	110.00	228.00	244.00
			60	109.00	158.00	163.00	111.00	167.00	174.00	115.00	180.00	188.00	119.00	190.00	201.00	124.00	208.00	222.00
			80	122.00	138.00	143.00	125.00	147.00	153.00	129.00	160.00	168.00	132.00	170.00	180.00	138.00	188.00	201.00
	3600	40	89.00	191.00	197.00	91.00	201.00	208.00	95.00	215.00	225.00	98.00	226.00	239.00	103.00	245.00	262.00	
		60	103.00	170.00	175.00	106.00	180.00	187.00	110.00	193.00	203.00	112.00	205.00	216.00	117.00	224.00	239.00	
		80	118.00	149.00	154.00	121.00	158.00	164.00	124.00	172.00	180.00	127.00	183.00	194.00	132.00	202.00	216.00	
10.00	TWE120A TWE120B	3200	40	99.00	203.00	210.00	102.00	214.00	222.00	106.00	229.00	240.00	109.00	241.00	254.00	115.00	261.00	279.00
			60	112.00	181.00	187.00	115.00	191.00	199.00	119.00	206.00	216.00	123.00	218.00	230.00	129.00	238.00	255.00
			80	126.00	158.00	164.00	129.00	169.00	175.00	133.00	183.00	192.00	136.00	195.00	206.00	142.00	215.00	230.00
		4000	40	91.00	222.00	229.00	94.00	234.00	243.00	98.00	250.00	262.00	101.00	264.00	278.00	106.00	286.00	306.00
			60	106.00	198.00	204.00	108.00	209.00	217.00	112.00	225.00	236.00	115.00	239.00	252.00	120.00	261.00	279.00
			80	120.00	173.00	179.00	123.00	184.00	192.00	126.00	200.00	210.00	129.00	214.00	226.00	134.00	236.00	252.00
	4800	40	86.00	239.00	246.00	88.00	251.00	261.00	92.00	269.00	282.00	94.00	284.00	299.00	99.00	307.00	329.00	
		60	101.00	212.00	219.00	103.00	225.00	233.00	107.00	242.00	254.00	109.00	257.00	271.00	114.00	280.00	300.00	
		80	116.00	186.00	192.00	118.00	198.00	206.00	121.00	215.00	226.00	124.00	230.00	243.00	129.00	253.00	271.00	
15.00	TWE180B	4800	40	97.00	295.00	304.00	100.00	310.00	322.00	104.00	332.00	348.00	107.00	350.00	369.00	113.00	379.00	406.00
			60	110.00	262.00	271.00	113.00	278.00	288.00	117.00	299.00	313.00	121.00	317.00	334.00	126.00	346.00	370.00
			80	124.00	230.00	237.00	127.00	245.00	254.00	131.00	266.00	279.00	134.00	284.00	299.00	140.00	313.00	334.00
		6000	40	90.00	322.00	332.00	92.00	339.00	352.00	96.00	363.00	380.00	99.00	383.00	404.00	104.00	415.00	444.00
			60	104.00	287.00	296.00	107.00	303.00	315.00	110.00	327.00	343.00	113.00	347.00	366.00	118.00	379.00	405.00
			80	119.00	251.00	259.00	121.00	268.00	278.00	125.00	291.00	305.00	128.00	310.00	328.00	133.00	342.00	366.00
	7200	40	84.00	346.00	356.00	87.00	364.00	378.00	90.00	390.00	408.00	93.00	411.00	434.00	97.00	446.00	477.00	
		60	99.00	308.00	318.00	102.00	326.00	338.00	105.00	351.00	368.00	108.00	373.00	393.00	112.00	407.00	435.00	
		80	115.00	270.00	278.00	117.00	287.00	299.00	120.00	313.00	327.00	123.00	334.00	352.00	127.00	368.00	394.00	
20.00	TWE240B	6400	40	95.00	379.00	391.00	97.00	399.00	414.00	102.00	427.00	447.00	105.00	450.00	475.00	110.00	488.00	522.00
			60	109.00	337.00	348.00	111.00	357.00	371.00	115.00	384.00	403.00	119.00	408.00	430.00	124.00	445.00	476.00
			80	123.00	295.00	305.00	125.00	315.00	327.00	129.00	342.00	358.00	133.00	365.00	385.00	138.00	402.00	430.00
		8000	40	88.00	414.00	426.00	90.00	436.00	452.00	94.00	467.00	488.00	97.00	492.00	519.00	102.00	534.00	571.00
			60	102.00	368.00	380.00	105.00	390.00	405.00	108.00	420.00	440.00	111.00	446.00	470.00	116.00	487.00	521.00
			80	117.00	322.00	333.00	120.00	344.00	357.00	123.00	374.00	392.00	126.00	399.00	421.00	131.00	440.00	471.00
	9600	40	83.00	443.00	457.00	85.00	468.00	485.00	88.00	501.00	524.00	91.00	529.00	558.00	95.00	574.00	613.00	
		60	98.00	395.00	407.00	100.00	418.00	434.00	103.00	451.00	473.00	106.00	479.00	505.00	110.00	524.00	560.00	
		80	113.00	346.00	357.00	115.00	369.00	383.00	119.00	402.00	421.00	121.00	429.00	453.00	125.00	473.00	506.00	

Type NS Coil, 1 Row, 1" OD, SF Fins, 132 Fins per Foot.

NOTES:

- 1 LAT – Leaving Air Temperature (F)
- 2 MBh Capacity: BTU/HR/1000
- 3 Cond. Lb/Hr – Condensate pound per hour.

Table PD-54: Airside Pressure Loss (inches of Water Gauge) – Cooling Coils

Tons	Unit Model No.	CFM	Dry Coil	Wet Coil
10.00	TXE120B500A	3200	0.27	0.32
		3600	0.31	0.40
		4000	0.37	0.47
		4400	0.45	0.56
		4800	0.53	0.65

Includes pressure loss thru clean 1" throwaway filters.

PRODUCT DATA

American Standard Inc.

Performance Data

5 - 20 Ton

Table PD-55: Hot Water Heating Coil Capacity – Air Handler

		Entering Water Temperature																			
		180.0									200.0										
		Water Temperature Drop (F)																			
Tons	Unit Model No.	Air Flow (CFM)	Entering Air Temp. (F)	20.0			30.0			40.0			20.0			30.0			40.0		
				GPM ¹	MBh ²	LAT ³	GPM ¹	MBh ²	LAT ³	GPM ¹	MBh ²	LAT ³	GPM ¹	MBh ²	LAT ³	GPM ¹	MBh ²	LAT ³	GPM ¹	MBh ²	LAT ³
5.00	TWE060A TWE060B	1600	40	10.9	106.1	101.0	6.6	96.5	96.0	4.5	87.4	90.0	12.9	124.9	112.0	7.9	115.4	106.0	5.5	106.3	101.0
			60	9.0	88.3	111.0	5.4	79.1	106.0	3.6	70.3	100.0	11.0	107.0	122.0	6.7	97.8	116.0	4.6	88.9	111.0
			80	7.2	70.6	121.0	4.2	61.8	116.0	2.7	53.4	111.0	9.2	89.1	131.0	5.5	80.2	126.0	3.7	71.7	121.0
		2000	40	12.3	119.8	95.0	7.4	108.6	90.0	5.0	97.9	851.0	4.5	141.3	105.0	8.9	130.1	100.0	6.1	119.4	95.0
			60	10.2	99.6	106.0	6.1	88.8	101.0	4.0	78.6	96.0	12.4	120.9	116.0	7.5	110.1	111.0	5.1	99.7	106.0
			80	8.1	79.5	117.0	4.7	69.2	112.0	3.0	59.6	107.0	10.4	100.6	126.0	6.2	90.2	122.0	4.1	80.3	117.0
	2400	40	13.5	132.0	91.0	8.1	119.2	86.0	5.5	107.1	811.0	6.0	155.8	100.0	9.8	143.1	95.0	6.7	131.0	90.0	
		60	11.2	109.6	102.0	6.6	97.4	97.0	4.4	85.9	931.0	3.7	133.3	111.0	8.3	120.9	106.0	5.6	109.2	102.0	
		80	9.0	87.4	114.0	5.2	75.7	109.0	3.3	64.9	105.0	11.4	110.8	123.0	6.8	98.9	118.0	4.5	87.8	114.0	
7½	TWE090A TWE090B	2400	40	17.0	165.9	104.0	10.4	152.3	98.0	7.1	139.2	93.0	20.0	194.8	115.0	12.4	181.2	110.0	8.6	168.2	105.0
			60	14.2	138.4	113.0	8.5	125.2	108.0	5.7	112.5	103.0	17.2	167.1	124.0	10.6	153.9	119.0	7.2	141.2	114.0
			80	11.4	111.1	123.0	6.7	98.3	118.0	4.4	86.1	113.0	14.4	139.6	134.0	8.7	126.8	129.0	5.9	114.3	124.0
		3000	40	19.3	187.9	98	11.7	171.9	93	8.0	156.5	88	22.7	220.9	108	14.0	204.9	103.0	9.7	189.6	98.0
			60	16.1	156.7	108.0	9.6	141.1	103.0	6.4	126.3	991.0	9.5	189.4	118.0	11.9	173.9	113.0	8.2	159.0	109.0
			80	12.9	125.5	119.0	7.5	110.6	114.0	4.9	96.5	110.0	16.3	158.1	129.0	9.8	143.0	124.0	6.6	128.5	119.0
	3600	40	21.2	207.3	93.0	12.9	189.1	88.0	8.8	171.6	84.0	25.1	244.0	102.0	15.5	225.7	981.0	0.7	208.4	93.0	
		60	17.7	172.7	104.0	10.6	155.0	100.0	7.1	138.3	95.0	21.5	209.1	113.0	13.1	191.4	109.0	9.0	174.4	105.0	
		80	14.2	138.2	115.0	8.3	121.2	111.0	5.4	105.4	107.0	17.9	174.3	125.0	10.8	157.1	120.0	7.2	140.9	116.0	
10	TWE120A TWE120B	3200	40	24.5	239.1	109.0	14.3	210.0	100.0	9.1	178.7	91.0	29.3	284.7	122.0	17.6	256.8	114.0	11.7	228.6	106.0
			60	20.2	197.3	117.0	11.5	168.4	108.0	6.9	134.8	99.0	25.0	242.6	130.0	14.7	215.2	122.0	9.6	186.9	114.0
			80	15.9	155.6	125.0	8.6	126.1	116.0	4.0	78.7	103.0	20.6	200.6	138.0	11.9	173.6	130.0	7.4	144.3	122.0
		4000	40	27.8	271.7	103.0	16.2	237.5	95.0	10.3	201.9	86.0	33.4	324.1	115.0	19.9	291.0	107.0	13.3	258.2	99.0
			60	22.9	223.8	112.0	13.0	190.3	104.0	7.8	153.3	95.0	28.4	275.8	124.0	16.7	243.6	116.0	10.8	211.0	109.0
			80	18.1	176.2	121.0	9.7	142.6	113.0	5.0	97.3	102.0	23.4	227.7	132.0	13.4	196.2	125.0	8.4	163.2	118.0
	4800	40	30.7	300.0	98.0	17.8	261.3	90.0	11.3	221.7	82.0	36.9	358.3	109.0	22.0	320.7	102.0	14.6	283.7	94.0	
		60	25.3	246.9	107.0	14.3	209.1	100.0	8.6	168.9	92.0	31.4	304.7	118.0	18.4	268.1	111.0	11.9	231.6	104.0	
		80	19.9	194.0	117.0	10.7	156.7	110.0	5.6	110.2	101.0	25.9	251.3	128.0	14.8	215.6	121.0	9.2	179.4	114.0	
15	TWE180B	4800	40	35.2	343.9	106.0	21.2	310.3	100.0	14.1	276.3	93.0	41.8	406.0	118.0	25.6	373.4	112.0	17.5	341.0	105.0
			60	29.3	285.7	115	17.2	252.7	108.0	11.2	218.5	102.0	35.8	347.5	127.0	21.6	315.4	121.0	14.6	283.4	114.0
			80	23.3	227.7	124.0	13.3	195.0	117.0	8.2	159.9	111.0	29.8	289.1	135.0	17.7	257.6	129.0	11.6	225.7	123.0
		6000	40	40.0	390.3	100.0	23.9	350.8	94.0	15.9	311.4	88.0	7.5	461.4	111.0	29.0	423.0	105.0	19.8	385.0	99.0
			60	33.3	323.9	110.0	19.5	285.3	104.0	12.6	246.2	98.0	40.6	394.6	121.0	24.5	356.9	115.0	16.4	319.6	109.0
			80	26.4	257.7	120.0	15.0	219.9	114.0	9.2	180.5	108.0	33.8	327.9	130.0	19.9	291.0	125.0	13.1	254.3	119.0
	7200	40	44.2	431.3	95.0	26.4	386.5	89.0	17.5	342.1	84.0	52.5	510.4	105.0	32.0	466.7	100.0	21.8	423.8	94.0	
		60	36.6	357.6	106.0	21.4	313.9	100.0	13.8	270.6	95.0	44.9	436.3	116.0	27.0	393.5	110.0	18.0	351.4	105.0	
		80	29.1	284.2	116.0	16.5	241.6	111.0	10.1	198.3	105.0	37.3	362.2	126.0	22.0	320.5	121.0	14.3	279.5	116.0	
20	TWE240B	6400	40	46.8	456.2	106.0	28.4	416.5	100.0	19.3	376.7	94.0	55.2	536.5	117.0	34.1	497.8	112.0	23.6	459.4	106.0
			60	39.0	380.2	115.0	23.3	341.2	109.0	15.4	301.7	103.0	47.4	460.2	126.0	28.9	422.1	121.0	19.7	384.2	115.0
			80	31.2	304.5	124.0	18.2	266.0	118.0	11.6	227.0	113.0	39.5	384.0	135.0	23.8	346.5	130.0	15.9	308.9	124.0
		8000	40	53.0	517.5	100.0	32.1	470.9	94.0	21.7	424.5	89.0	62.7	609.2	110.0	38.6	563.8	105.0	26.6	518.8	100.0
			60	44.2	430.9	110.0	26.3	385.2	104.0	17.4	339.6	99.0	53.8	522.2	120.0	32.7	477.6	115.0	22.2	433.3	110.0
			80	35.3	344.6	120.0	20.5	299.8	115.0	13.0	255.2	109.0	44.8	435.4	130.0	26.8	391.5	125.0	17.9	347.9	120.0
	9600	40	58.6	572.0	94.0	35.4	519.9	90.0	23.9	466.8	85.0	69.4	673.9	105.0	42.7	622.3	100.0	29.3	571.5	95.0	
		60	48.8	475.9	106.0	28.9	424.2	101.0	19.1	373.3	96.0	59.4	577.4	115.0	36.1	526.8	111.0	24.5	476.7	106.0	
		80	39.0	380.2	116.0	22.5	329.6	112.0	14.3	280.0	107.0	49.5	481.0	126.0	29.6	431.4	121.0	19.6	382.6	117.0	

Type W Coil, 2 Row, 5/8" OD, PH Fins,

Tons	Fin/Ft.	NOTES:
5	131	1 GPM – Gallons per minute
7	125	2 MBh Capacity: BTU/HR/1000
10	167	3 LAT – Leaving Air Temperature (F)
15	151	
20	148	

Performance Data

5 - 20 Ton

Table PD-55 (continued): Hot Water Heating Coil Capacity – Air Handler

Tons	Unit Model No.	Air Flow (CFM)	Entering Air Temp. (F)	Entering Water Temperature 210.0										
				Water Temperature Drop (F)										
				20.0			30.0			40.0				
				GPM ¹	MBh ²	LAT ³	GPM ¹	MBh ²	LAT ³	GPM ¹	MBh ²	LAT ³		
5	TWE060A TWE060B	1600	40	13.9	134.3	117.0	8.6	124.8	112.0	6.0	115.8	107.0		
			60	12.0	116.3	127.0	7.4	107.1	122.0	5.1	98.3	117.0		
			80	10.2	98.4	137.0	6.1	89.5	132.0	4.2	80.9	127.0		
		2000	40	40	15.7	152.0	110.0	9.7	140.9	105.0	6.7	130.2	100.0	
				60	13.6	131.6	121.0	8.3	120.7	116.0	5.7	110.5	111.0	
				80	11.5	111.2	131.0	6.9	100.7	126.0	4.7	90.7	122.0	
			2400	40	40	17.3	167.7	104.0	10.6	155.0	99.0	7.4	142.9	95.0
					60	15.0	145.1	116.0	9.1	132.8	111.0	6.2	121.0	106.0
					80	12.6	122.6	127.0	7.6	110.6	122.0	5.1	99.3	118.0
7½	TWE090A TWE090B	2400	40	21.6	209.2	120.0	13.4	195.7	115.0	9.4	182.7	110.0		
			60	18.7	181.5	130.0	11.6	168.3	125.0	8.0	155.6	120.0		
			80	15.9	153.9	139.0	9.7	141.0	134.0	6.6	28.6	129.0		
		3000	40	40	24.5	237.4	113.0	15.2	221.5	108.0	10.6	206.2	103.0	
				60	21.2	205.8	123.0	13.1	190.3	118.0	9.0	175.4	114.0	
				80	18.0	174.4	134.0	10.9	159.2	129.0	7.4	144.7	124.0	
			3600	40	40	27.1	262.3	107.0	16.8	244.1	102.0	11.7	226.8	98.0
					60	23.4	227.3	118.0	14.4	209.6	114.0	9.9	192.6	109.0
					80	19.8	192.4	129.0	12.0	175.2	125.0	8.2	158.7	121.0
10	TWE120A TWE120B	3200	40	31.7	307.4	129.0	19.2	279.9	121.0	13.0	252.6	113.0		
			60	27.4	265.1	136.0	16.4	238.2	129.0	10.9	211.0	121.0		
			80	23.0	223.0	144.0	13.5	196.5	137.0	8.7	169.1	129.0		
		4000	40	40	36.1	350.2	121.0	21.8	317.6	113.0	14.7	285.5	106.0	
				60	31.1	301.7	130.0	18.5	269.9	122.0	12.3	238.2	115.0	
				80	26.1	253.4	138.0	15.3	222.3	131.0	9.8	190.8	124.0	
			4800	40	40	40.0	387.4	114.0	24.1	350.3	107.0	16.2	313.9	100.0
					60	34.4	333.6	124.0	20.4	297.3	117.0	13.5	261.7	110.0
					80	28.9	279.9	134.0	16.8	244.6	127.0	10.8	209.5	120.0
15	TWE180B	4800	40	45.1	437.0	124.0	27.8	404.7	118.0	19.2	372.9	112.0		
			60	39.0	378.3	133.0	23.8	346.6	127.0	16.2	315.2	120.0		
			80	33.0	319.8	141.0	19.8	288.6	135.0	13.3	257.5	129.0		
		6000	40	40	51.3	496.8	116.0	31.5	458.9	110.0	21.7	421.5	105.0	
				60	44.4	429.9	126.0	27.0	392.6	120.0	18.3	355.8	115.0	
				80	37.5	363.0	136.0	22.4	326.5	130.0	14.9	290.3	125.0	
			8000	40	40	56.7	549.8	110.0	34.8	506.7	105.0	23.9	464.3	99.0
					60	49.1	475.5	121.0	29.8	433.1	115.0	20.2	391.5	110.0
					80	41.4	401.3	131.0	24.7	359.8	126.0	16.4	319.0	121.0
20	TWE240B	6400	40	59.5	576.5	123.0	37.0	538.3	118.0	25.8	500.5	112.0		
			60	51.6	500.0	132.0	31.8	462.4	127.0	21.9	425.0	121.0		
			80	43.7	423.7	141.0	26.6	386.6	136.0	18.0	349.7	130.0		
		8000	40	40	67.6	654.9	115.0	41.9	610.0	110.0	29.1	565.7	105.0	
				60	58.6	567.8	125.0	36.0	523.6	120.0	24.7	479.9	115.0	
				80	49.6	480.7	135.0	30.0	437.3	130.0	20.3	394.2	125.0	
			9600	40	40	74.8	724.6	110.0	46.3	673.8	105.0	32.1	623.6	100.0
					60	64.8	628.0	120.0	39.7	578.0	115.0	27.2	528.4	111.0
					80	54.8	531.4	131.0	33.1	482.2	126.0	22.3	433.5	122.0

Type W Coil, 2 Row, 5/8" OD, PH Fins,

Tons	Fin/Ft.
5	131
7	125
10	167
15	151
20	148

NOTES:

- 1 GPM – Gallons per minute
- 2 MBh Capacity: BTU/HR/1000
- 3 LAT – Leaving Air Temperature (F)

PRODUCT DATA

American Standard Inc.

Performance Data

5 - 20 Ton

Table PD-56: Hot Water Heating Coil – Water Side Pressure Drop @ 180 – Air Handler

Tons	Unit Model No.	Gallons per Minute (GPM)																	
		2	4	6	8	10	12	14	16	18	20	22	24	26	28	30	32	34	36
	TWE060A	Pressure Drop (Ft. of Water)																	
5	TWE060B	.02	.07	.15	.26	.40	.56	.75	.97	1.22	1.49	1.78	—	—	—	—	—	—	—
7½	TWE090A	—																	
	TWE090B	—	—	.06	.11	.16	.23	.30	.39	.48	.58	.70	.82	.95	1.09	1.24	1.40	1.57	—
	TWE120A	—																	
10	TWE120B	—	—	—	.06	.09	.13	.17	.22	.27	.33	.39	.46	.54	.62	.70	.79	.89	.99
15	TWE180B	—	—	—	—	.11	.15	.20	.26	.32	.39	.47	.55	.64	.73	.83	.94	1.05	1.17
20	TWE240B	—	—	—	—	—	.17	.23	.30	.37	.45	.53	.63	.72	.83	.94	1.06	1.19	1.32

Table PD-56 (continued): Hot Water Heating Coil – Water Side Pressure Drop @ 180 – Air Handler

Tons	Unit Model No.	Gallons per Minute (GPM)																	
		40	42	44	46	48	50	52	54	56	58	60	62	64	66	68	70	72	74
	TWE060A	Pressure Drop (Ft. of Water)																	
5	TWE060B	—																	
7½	TWE090A	—																	
	TWE090B	—																	
	TWE120A	—																	
10	TWE120B	1.21	1.32	1.44	1.57	1.70	1.84	—	—	—	—	—	—	—	—	—	—	—	—
15	TWE180B	1.42	1.56	1.70	1.85	2.00	2.16	2.33	2.50	2.67	2.86	3.04	3.24	3.44	3.64	3.85	4.07	—	—
20	TWE240B	1.61	1.76	1.92	2.09	2.26	2.44	2.63	2.82	3.02	3.22	3.43	3.65	3.87	4.10	4.34	4.58	4.83	5.08

Controls

Programmable Electronic Night Setback Thermostat — Heating setback and cooling setup with 7-day, 5-1-1 programming capability. Available in 2 heating/cooling or 1 heating/cooling versions with automatic changeover.

- Digital display indicating time of day, day of week, room temperature, current program operating mode and current active stage.
- Instant override, continuous or temporary 3 hour times.
- Automatic adjustment of temperatures up to four times a day.
- L.C.D. read out in Fahrenheit (F) or Celsius (C); and 12 or 24-hour clock.
- Preferential Rate Control (PRC); minimizes overshooting and prevents room temperature deviating from setpoint under varying load conditions (zero droop).
- PRC provides smart recovery from offset to minimize use of supplemental electric heat.
- Keyboard disable to prevent tampering.
- 100% solid state.

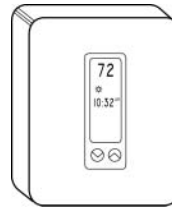

Cooling Only Thermostat —
• Off/Auto Fan System Switch

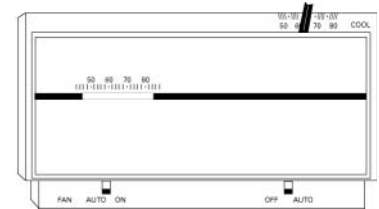

1 Heat/1 Cool Thermostat —

With Manual Changeover Subbase:

- Instant on Fan (for electric heat)
- Heat/Off/Cool System Switch
- Auto/On Fan Switch

With Automatic Changeover Subbase:

- Off/Auto System Switch

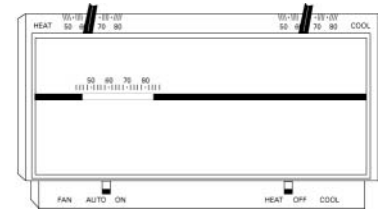

2 Heat/2 Cool Thermostat —

With Manual or Automatic Changeover Subbase:

- Off Heat/Auto/Cool System Switch
- Auto/On Fan Switch

With Manual Changeover Subbase:

- Instant on Fan (for electric heat)
- Heat/Off/Cool System Switch
- Auto/On Fan Switch

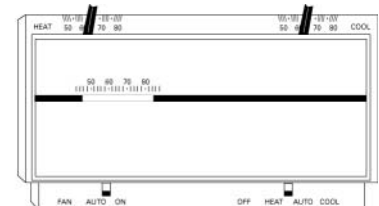

With Automatic Changeover Subbase:

- Off/Auto System Switch
- Auto/On Fan Switch

PRODUCT DATA

American Standard Inc.

Electrical Data

Table ED-1: Electrical Characteristics - Motors - 60 Cycle - Condensing Units

Tons	Unit Model No.	No.	Compressor Motor				Condenser Fan Motor				
			Volts	Phase	Amps		No.	Volts	Phase	Amps	
					RLA (Ea.)	LRA (Ea.)				FLA (Ea.)	LRA (Ea.)
7½	TTA090A3	1	208-230	3	25.1	182	1	208-230	1	3.1	8.1
	TTA090A4	1	460	3	13.2	94.9	1	460	1	1.6	3.7
	TTA090AK	1	380	3	15	106.3	1	380	1	2.2	5.8
	TTA090AW	1	575	3	10.6	70	1	575	1	1.2	3
10	TTA120A3	1	208-230	3	33.7	278	1	208-230	1	6	17
	TTA120A4	1	460	3	16.5	1240	1	460	1	2.7	7
	TTA120AK	1	380	3	18.1	137	1	380	1	3.4	7.8
	TTA120AW	1	575	3	13.4	92	1	575	1	2	5.7
	TTA120B3	2	208-230	3	18.6	128	1	208-230	1	6	17
	TTA120B4	2	460	3	9.4	63	1	460	1	2.7	7
	TTA120BK	2	380	3	12.7	82	1	380	1	3.4	7.8
	TTA120BW	2	575	3	7.6	49	1	575	1	2	5.7
	TTA120C3	2	208-230	3	17.7	123	1	208-230	1	6	17
	TTA120C4	2	460	3	9	62	1	460	1	2.7	7
	TTA120CW	2	575	3	7.1	50	1	575	1	2	5.7
	12½	TTA150B3	2	208-230	3	22	156	1	208-230	1	6
TTA150B4		2	460	3	11.3	75	1	460	1	2.7	7
TTA150BK		2	380	3	13.3	63	1	380	1	3.4	7.8
TTA150BW		2	575	3	8.7	54	1	575	1	2	5.7
15	TTA180B3	2	208-230	3	25.1	182	2	208-230	1	3.1	8.1
	TTA180B4	2	460	3	13.2	94.9	2	460	1	1.6	3.7
	TTA180BK	2	380	3	15	106.3	2	380	1	2.2	5.8
	TTA180BW	2	575	3	10.6	70	2	575	1	1.2	3
20	TTA180C3	2	208-230	3	25.1	182	2	208-230	1	3.1	8.1
	TTA180C4	2	460	3	13.2	94.9	2	460	1	1.6	3.8
	TTA180CW	2	575	3	10.6	70	2	575	1	1.2	3
	TTA240B3	2	208-230	3	33.7	278	2	208-230	1	6	17
20	TTA240B4	2	460	3	16.5	124	2	460	1	2.7	7
	TTA240BK	2	380	3	18.1	137	2	380	1	3.4	7.8
	TTA240BW	2	575	3	13.4	92	2	575	1	2	5.7

NOTES:

1 Electrical characteristics reflect nameplate values and are calculated in accordance with UL and ARI specifications.

Table ED-2: Unit Wiring - Condensing Units

Tons	Unit Model No.	Unit Operating Voltage Range	Minimum Circuit Ampacity	Maximum Fuse Size or Maximum Circuit Breaker ²
7½	TTA090A3	187-253	34.5	50
	TTA090A4	414-506	18.1	25
	TTA090AK	342-418	21	30
	TTA090AW	518-632	14.5	20
10	TTA120A3	187-253	48.1	70
	TTA120A4	414-506	23.3	35
	TTA120AK	342-418	26	40
	TTA120AW	518-632	18.8	25
	TTA120B3	187-253	47.9	60
	TTA120B4	414-506	23.9	30
	TTA090BK	342-418	32	40
	TTA120BW	518-632	19.1	25
12½	TTA120C3	187-253	49.4	60
	TTA120C4	414-506	25.2	30
	TTA120CW	518-632	19.8	25
	TTA150B3	187-253	55.5	70
	TTA150B4	414-506	28.1	35
	TTA150BK	342-418	33.3	40
	TTA150BW	518-632	21.6	25

NOTES:

1. Electrical characteristics reflect nameplate values and are calculated in accordance with UL and ARI specifications.

7 1/2 and 10 ton values are system rated; 12 1/2, 15 and 20 ton values are condensing unit only rated.

2. HACR type circuit breaker per NEC.

Table ED-2: (Continued)

Tons	Unit Model No.	Unit Operating Voltage Range	Minimum Circuit Ampacity	Maximum Fuse Size or Maximum Circuit Breaker ²
15	TTA180B3	187-253	62.7	80
	TTA180B4	414-506	32.9	45
	TTA180BK	342-418	38.2	50
	TTA180BW	518-632	26.3	35
20	TTA180C3	187-253	62.7	80
	TTA180C4	414-506	32.9	45
	TTA180CW	518-632	26.3	35
	TTA240B3	187-253	87.8	100
20	TTA240B4	414-506	42.5	50
	TTA240BK	342-418	47.5	60
	TTA240BW	518-632	34.2	45

Electrical Data

Table ED-3: Unit Wiring - Air Handler

Tons	Minimum Unit Model No.	Maximum Fuse Unit Operating Voltage Range	Circuit Ampacity	Size or Maximum Circuit Breaker ³
5	TWE060A1,B1	187-253	7	15
	TWE060A3,B3	187-253	4	15
	TWE060A4,B4	414-506	2	15
	TWE060AW	518-632	2	15
7½	TWE090A1, B1	187-253	8	15
	TWE090A3, B3 ¹	187-253	7	15
	TWE090A3, B3 ²	414-506	4	15
	TWE090AW	518-632	4	15
10	TWE120A1,B1	187-253	11	15
	TWE120A3,B3 ¹	187-253	8	15
	TWE120A4,B4 ²	414-506	5	15
	TWE120AW,BW	518-632	4	15
15	TWE180B3	187-253	12	20
	TWE180B4	414-506	6	15
	TWE180BW	518-632	5	15
20	TWE240B3	187-253	19	30
	TWE240B4	414-506	9	15
	TWE240BW	518-632	7	15

NOTES:

- 1 When wired for 208-230 volt.
- 2 When wired for 460 volt.
- 3 HACR type circuit breaker per NEC.

Table ED-4: Electrical Characteristics - Motors - 60 Cycle - Air Handler

Tons	Unit Model No.	Standard Evaporator Fan Motor					Oversized Evaporator Fan Motor				
		No.	Volts	Phase	Amps		No.	Volts	Phase	Amps	
					FLA	LRA				FLA	LRA
5	TWE060A1, B1	1	208-230	1	5.6	45	1	208-230	1	6.3	45
	TWE060A3, B3	1	208-230	3	2.6	16.4	1	208-230	3	3.6	22
	TWE060A4, B4	1	460	3	1.3	8.2	1	460	3	1.8	11
	TWE060AK	1	380	3	1.4	9.9	-	-	-	-	-
	TWE060AW	1	575	3	1.3	6.6	1	575	3	1.7	10.8
7½	TWE090A1, B1	1	208-230	1	6.2	33	1	208-230	1	7.7	57.4
	TWE090A3, B3 ¹	1	208-230/460	3	5.0/2.5	34.3/17.0	1	208-230/460	3	6.0/3.4	49.0/27.5
	TWE090AK	1	380	3	2.5	23.8	-	-	-	-	-
10	TWE090AW	1	575	3	3.1	15	1	575	3	2.6	17.5
	TWE120A1,B1	1	208-230	1	8.3	57.4	1	208-230	1	-	-
	TWE120A3,B3 ¹ ,A4,B4	1	208-230/460	3	6.0/3.4	49.0/27.5	1	208-230/460	3	9.4/4.6	74.9/39.3
	TWE120AK,BK	1	380	3	3.0	30.9	-	-	-	-	-
15	TWE120AW,BW	1	575	3	2.6	17.5	1	575	3	5.4	37.3
	TWE180B3	1	208-230	3	9.4	74.9	1	208-230	3	14.4	98
	TWE180B4	1	460	3	4.6	39.3	1	460	3	6.7	47
	TWE180BK	1	380	3	7.3	54.5	-	-	-	-	-
20	TWE180BW	1	575	3	3.4	24.6	1	575	3	5.4	37.3
	TWE240B3	1	208-230	3	14.5	98	1	208-230	3	18	122.8
	TWE240B4	1	460	3	6.7	47	1	460	3	9	61.4
	TWE240BK	1	380	3	10.0	53.9	-	-	-	-	-
	TWE240BW	1	575	3	5.4	37.3	1	575	3	7.2	49.8

NOTES:

- 1 Ships wired for 208-230/3/60. Field convertible to 460/3/60.

PRODUCT DATA

American Standard Inc.

Electrical Data

Table ED-5: Unit Wiring with Electric Heat (Single Point Connection) - 5, 7 1/2 and 10 Ton Air Handlers

Heater Model No.	Maximum Fuse Heater KW Rating ¹	To Use With Unit	Unit Power Supply	Control Stages	Minimum Circuit Ampacity ²	or HACR Circuit Breaker Size ^{2, 6}
BAYHTRL106A	4.33/5.76			1	33/37	35/40
BAYHTRL112A	8.65/11.52	TWE060A1	208-230/1/60	1	59/67 ³	60/70
BAYHTRL117A	12.98/17.28	TWE060B1		1	88/97	90/100
BAYHTRL123A	17.30/23.04			2	111/127 ³	125/150
BAYHTRL106A	4.33/5.76			1	34/38	35/40
BAYHTRL112A	8.65/11.52			1	60/68 ³	60/70
BAYHTRL117A	12.98/17.28	TWE090A1	208-230/1/60	1	86/98	90/100
BAYHTRL123A	17.30/23.04	TWE090B1		2	112/128 ³	125/150
BAYHTRL129A	21.65/28.80			2	138/158 ³	150/175
BAYHTRL106A	4.33/5.76			1	31/41	40/45
BAYHTRL112A	8.65/11.52			1	63/73 ³	70/80
BAYHTRL117A	12.98/17.28	TWE120A1	208-230/1/60	1	89/101	90/110
BAYHTRL123A	17.30/23.08	TWE120B1		2	115/131 ³	125/150
BAYHTRL129A	21.65/28.80			2	141/161 ³	150/175
BAYHTRL305A	3.75/5.00			1	17/19	20/20
BAYHTRL310A	7.45/9.96	TWE060A3	208-230/3/60	1	30/34	30/35
BAYHTRL315A	11.25/14.96	TWE060B3		1	43/49	45/50
BAYHTRL325A	18.71/24.92			2	69/79 ³	70/80
BAYHTRL305A	3.75/5.00			1	20/22	20/25
BAYHTRL310A	7.45/9.96			1	33/37	35/40
BAYHTRL315A	11.25/14.96	TWE090A3	208-230/3/60	1	46/52	50/60
BAYHTRL325A	18.71/24.92	TWE090B		2	72/82 ³	80/90
BAYHTRL335A	26.20/34.88			2	97/112 ⁴	100/125
BAYHTRL305A	3.75/5.00			1	21/23	25/25
BAYHTRL310A	7.45/9.96			1	34/38	35/40
BAYHTRL315A	11.25/14.96	TWE120A3	208-230/3/60	1	47/53	50/60
BAYHTRL325A	18.71/24.92	TWE120B3		2	73/83 ³	80/90
BAYHTRL335A	26.20/34.88			2	98/113 ⁴	100/125
BAYHTRL405A	5			1	10	15
BAYHTRL410A	9.96	TWE060A4	460/3/60	1	17	20
BAYHTRL415A	14.96	TWE060B4		1	25	25
BAYHTRL425A	24.92			2	40	40
BAYHTRL405A	5			1	11	15
BAYHTRL410A	9.96			1	19	20
BAYHTRL415A	14.96	TWE090A35	460/3/60	1	26	30
BAYHTRL425A	24.92	TWE090B35		2	41	45
BAYHTRL435A	34.88			2	56	60
BAYHTRL405A	5			1	12	15
BAYHTRL410A	9.96			1	20	20
BAYHTRL415A	14.96	TWE120A35	460/3/60	1	27	30
BAYHTRL425A	24.92	TWE120B35		2	42	45
BAYHTRL435A	34.88			2	57	60
BAYHTRLW05A	5			1	8	15
BAYHTRLW10A	9.96			1	15	15
BAYHTRLW15A	14.96	TWE060AW	575/3/60	1	21	25
BAYHTRLW25A	24.92			2	33	35
BAYHTRLW05A	5			1	11	15
BAYHTRLW10A	9.96			1	17	20
BAYHTRLW15A	14.96	TWE090AW	575/3/60	1	23	25
BAYHTRLW25A	24.92			2	36	40
BAYHTRLW35A	34.88			2	48	50
BAYHTRLW05A	5			1	10	15
BAYHTRLW10A	9.96			1	16	20
BAYHTRLW15A	14.96	TWE120AW	575/3/60	1	22	25
BAYHTRLW25A	24.92	TWE120BW		2	35	35
BAYHTRLW35A	34.88			2	47	50

NOTES:

1 kW ratings are at: 208/240V for 208-230V air handlers.

- 480V for 460V air handlers
- 600V for 575V air handlers

For other than rated voltage, capacity = $(\frac{\text{Voltage}}{\text{Rated Voltage}})^2 \times \text{Rated Capacity}$.

2 Any power supply and circuits must be wired and protected in accordance with local codes.

3 Field wire must be rated at least 75 C.

4 Field wire must be rated at least 90 C.

5 With motor field converted to 460V.

6 The HACR circuit breaker is for U.S.A. installations only.

Electrical Data

Table ED-6: Unit Wiring with Electric Heat (Single Point Connection) - 15 and 20 Ton Air Handlers

Heater Model No.	Heater KW Rating ¹	To Use With Unit	Unit Power Supply	Control Stages	Minimum Circuit Ampacity ²	Maximum Fuse or HACR Circuit Breaker Size ^{2,6}
BAYHTRM310A	7.50/10.00			1	38/42	40/45
BAYHTRM320A	14.96/19.92			1	64/72	70/80
BAYHTRM330A	22.50/29.92	TWE180B3	208-230/3/60	2	90/102	90/110
BAYHTRM350A	37.42/49.84			2	142/162 ⁴	150/175
BAYHTRM310A	7.50/10.00			1	45/49	50/50
BAYHTRM320A	14.96/19.92			1	71/79	80/80
BAYHTRM330A	22.50/29.92	TWE240B3	208-230/3/60	2	97/109	100/110
BAYHTRM350A	37.42/49.84			2	144/169 ⁴	150/175
BAYHTRM410A	10			1	21	25
BAYHTRM420A	19.92			1	36	40
BAYHTRM430A	29.92	TWE180B4	460/3/60	2	51	60
BAYHTRM450A	49.84			2	81	90
BAYHTRM410A	10			1	24	25
BAYHTRM420A	19.92			1	34	40
BAYHTRM430A	29.92	TWE240B4	460/3/60	2	54	60
BAYHTRM450A	49.84			2	84	90
BAYHTRMW10A	10			1	17	20
BAYHTRMW20A	19.92			1	30	30
BAYHTRMW30A	29.92	TWE180BW	575/3/60	2	42	45
BAYHTRMW50A	49.84			2	67	70
BAYHTRMW10A	10			1	20	25
BAYHTRMW20A	19.92			1	32	35
BAYHTRMW30A	29.92	TWE240BW	575/3/60	2	45	50
BAYHTRMW50A	49.84			2	70	80

NOTES:

- 1 kW ratings are at: 208/240V for 208-230V air handlers.
 - 480V for 460V air handlers
 - 600V for 575V air handlers

For other than rated voltage, capacity = $(\frac{\text{Voltage}}{\text{Rated Voltage}})^2 \times \text{Rated Capacity}$.

- 2 Any power supply and circuits must be wired and protected in accordance with local codes.
- 3 Field wire must be rated at least 75 C.
- 4 Field wire must be rated at least 90 C.
- 5 With motor field converted to 460V.
- 6 The HACR circuit breaker is for U.S.A. installations only.

PRODUCT DATA

American Standard Inc.

Jobsite Connections

Wiring shown with dashed lines is to be furnished and installed by the customer. All customer-supplied wiring must be copper only and must conform to NEC and local electrical codes. Codes may require line of sight between disconnect switch and unit.

NOTE:

1. When electric heater accessory is used single point power entry or dual point power entry is field optional. Single point power entry option is through electric heater only.

TTA060/TWE060A

Field Wiring:

- A — 3 power wires. Line voltage for 3 phase; 2 wires for single phase.
- B — 3 power wires. Line voltage for 3 phase; 2 wires for single phase
- C — Cooling only thermostat: 3 wires, 24 volts.
 - One Stage Electric heat: add 1 additional wire, 24 volts.
 - Two Stage Electric heat: add 2 additional wires, 24 volts.
- D — 2 wires, 24 volts.

(2) TTA048/TWE090B

(2) TTA060/TWE120B

Field Wiring:

- A — 3 power wires. Line voltage for 3 phase; 2 wires for single phase.
- B — 3 power wires. Line voltage for 3 phase; 2 wires for single phase.
- C — Cooling only thermostat: 4 wires, 24 volts Electric Heat: add 2 additional wires, 24 volts.
 - One Stage Electric heat: add 1 additional wire, 24 volts.
 - Two Stage Electric heat: add 2 additional wires, 24 volts.
- D — 2 wires, 24 volts to outdoor section "A"
 - 2 wires, 24 volts to outdoor section "B"

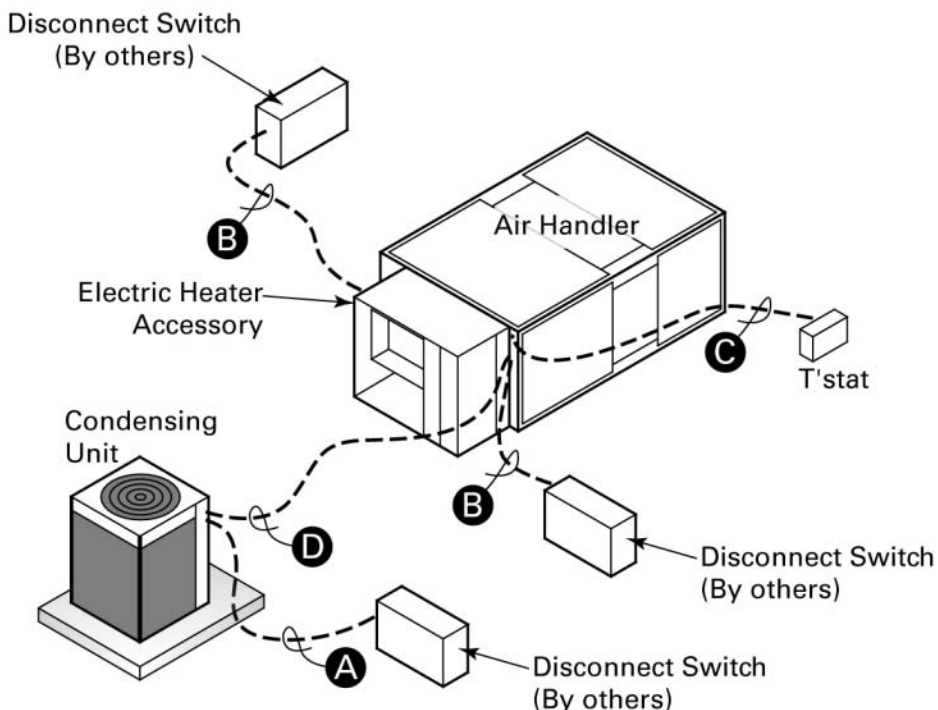

TTA090A/TWE090A

TTA120A/TWE120A

TTA120C/TWE120A

Field Wiring:

- A — 3 power wires, line voltage.
- B — 3 power wires, line voltage for 3 phase; 2 wires for single phase.
- C — Cooling only thermostat: 3 wires, 24 volts.
 - One Stage Electric heat: add 1 additional wire, 24 volts.
 - Two Stage Electric heat: add 2 additional wires, 24 volts.
- D — 4 wires, 24 volts.

(2) TTA120B/TWE120B

Field Wiring:

- A — 3 power wires, line voltage.
- B — 3 power wires, line voltage for 3-phase.
- C — Cooling only thermostat: 4 wires, 24 volts.
 - One Stage Electric heat: add 1 additional wire, 24 volts.
 - Two Stage Electric heat: add 2 additional wires, 24 volts.
- D — 5 wires, 24 volts.

TTA150B/TWE180B

TTA180B/TWE180B

TTA240B/TWE240B

TTA180C/TWE180B

Field Wiring:

- A — 3 power wires, line voltage.
- B — 3 power wires, line voltage.
- C — Cooling only thermostat: 4 wires, 24 volts.
 - One Stage Electric heat: add 1 additional wire, 24 volts.
 - Two Stage Electric heat: add 2 additional wires, 24 volts.
- D — 5 wires, 24 volts.

(2)TTA090A/TWE180B

(2)TTA120A/TWE240B

Field Wiring:

- A — 3 power wires, line voltage.
- B — 3 power wires, line voltage.
- C — Cooling only thermostat: 4 wires, 24 volts.
 - One Stage Electric heat: add 1 additional wire, 24 volts.
 - Two Stage Electric heat: add 2 additional wires, 24 volts.
- D — 6 wires, 24 volts.

Jobsite Connections

For ReliaTel Controls

Wiring shown with dashed lines is to be furnished and installed by the customer. All customer-supplied wiring must be copper only and must conform to NEC and local electrical codes. Codes may require line of sight between disconnect switch and unit.

NOTE:

2. When electric heater accessory is used single point power entry or dual point power entry is field optional. Single point power entry option is through electric heater only.

***Choose only one of the following; Thermostat, Zone Sensor, or NSB Panel.

TTA120A

Field Wiring:

- A – 3 power wires. Line voltage.
- B – 3 power wires. Line voltage for 3 phase; 2 wires for single phase
- C – Cooling only thermostat: 3 wires, 24 volts. *Digital thermostat: Add 1 additional wire, 24 volt common*
 - One Stage Electric heat: add 1 additional wire, 24 volts.
 - Two Stage Electric heat: add 2 additional wires, 24 volts.
- D – Add 4 wires, 24 volts.
 - One Stage Electric heat: add 1 additional wire, 24 volts.
 - Two Stage Electric heat: add 2 additional wires, 24 volts.
- E – Zone sensor: 2 wires minimum or 10 wires maximum, 24 volts (# of wires are dependent upon zone sensor selection).
- F – NSB Panel: 8 wires, 24 volts.

TTA120B & 100B/TWE120B & 100B TTA120C/TWE120A

Field Wiring:

- A – 3 power wires. Line voltage.
- B – 3 power wires. Line voltage for 3 phase; 2 wires for single phase.
- C – Cooling only thermostat: 4 wires, 24 volts. *Digital thermostat: Add 1 additional wire, 24 volt common*
 - One Stage Electric heat: add 1 additional wire, 24 volts.
 - Two Stage Electric heat: add 2 additional wires, 24 volts.
- D – Add 4 wires, 24 volts.

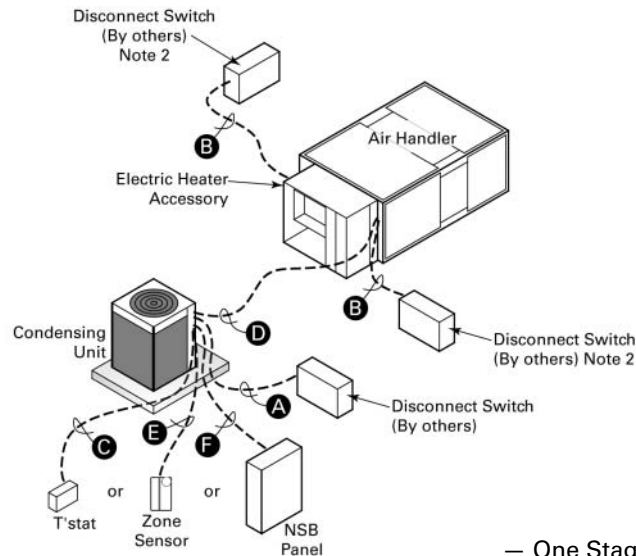

- One Stage Electric heat: add 1 additional wire, 24 volts.
- Two Stage Electric heat: add 2 additional wires, 24 volts.
- D – Add 4 wires, 24 volts.
 - One Stage Electric heat: add 1 additional wire, 24 volts.
 - Two Stage Electric heat: add 2 additional wires, 24 volts.
- E – Zone sensor: 2 wires minimum or 10 wires maximum, 24 volts (# of wires are dependent upon zone sensor selection).
- F – NSB Panel: 8 wires, 24 volts.

TTA150A/TWE180A TTA120A/TWE120A TTA240B/TWE240B TTA180C/TWE180B

Field Wiring:

- A – 3 power wires, line voltage.
- B – 3 power wires, line voltage for 3 phase; 2 wires for single phase.
- C – Cooling only thermostat: 3 wires, 24 volts. *Digital thermostat: Add 1 additional wire, 24 volt common*
 - One Stage Electric heat: add 1 additional wire, 24 volts.
 - Two Stage Electric heat: add 2 additional wires, 24 volts.
- D – Add 4 wires, 24 volts.

- One Stage Electric heat: add 1 additional wire, 24 volts.
- Two Stage Electric heat: add 2 additional wires, 24 volts.
- E – Zone sensor: 2 wires minimum or 10 wires maximum, 24 volts (# of wires are dependent upon zone sensor selection).
- F – NSB Panel: 8 wires, 24 volts.

(2) TTA090A/TWE180B (2) TTA120A/TWE240B

Field Wiring:

- A – 3 power wires, line voltage.
- B – 3 power wires, line voltage for 3 phase; 2 wires for single phase.
- C – Cooling only thermostat: 6 wires, 24 volts. *Digital thermostat: Add 2 additional wires, 24 volt common*
 - One Stage Electric heat: add 1 additional wire, 24 volts.
 - Two Stage Electric heat: add 2 additional wires, 24 volts.
- D – Add 8 wires, 24 volts.
 - One Stage Electric heat: add 1 additional wire, 24 volts.
 - Two Stage Electric heat: add 2 additional wires, 24 volts.
- E – Zone sensor: 2 wires minimum or 10 wires maximum, 24 volts (# of wires are dependent upon zone sensor selection).
- F – NSB Panel: 8 wires, 24 volts.

PRODUCT DATA

American Standard Inc.

Typical Wiring Air Handler

Air Handler

Typical unit wiring diagram. For specific wiring, see individual Service Facts.

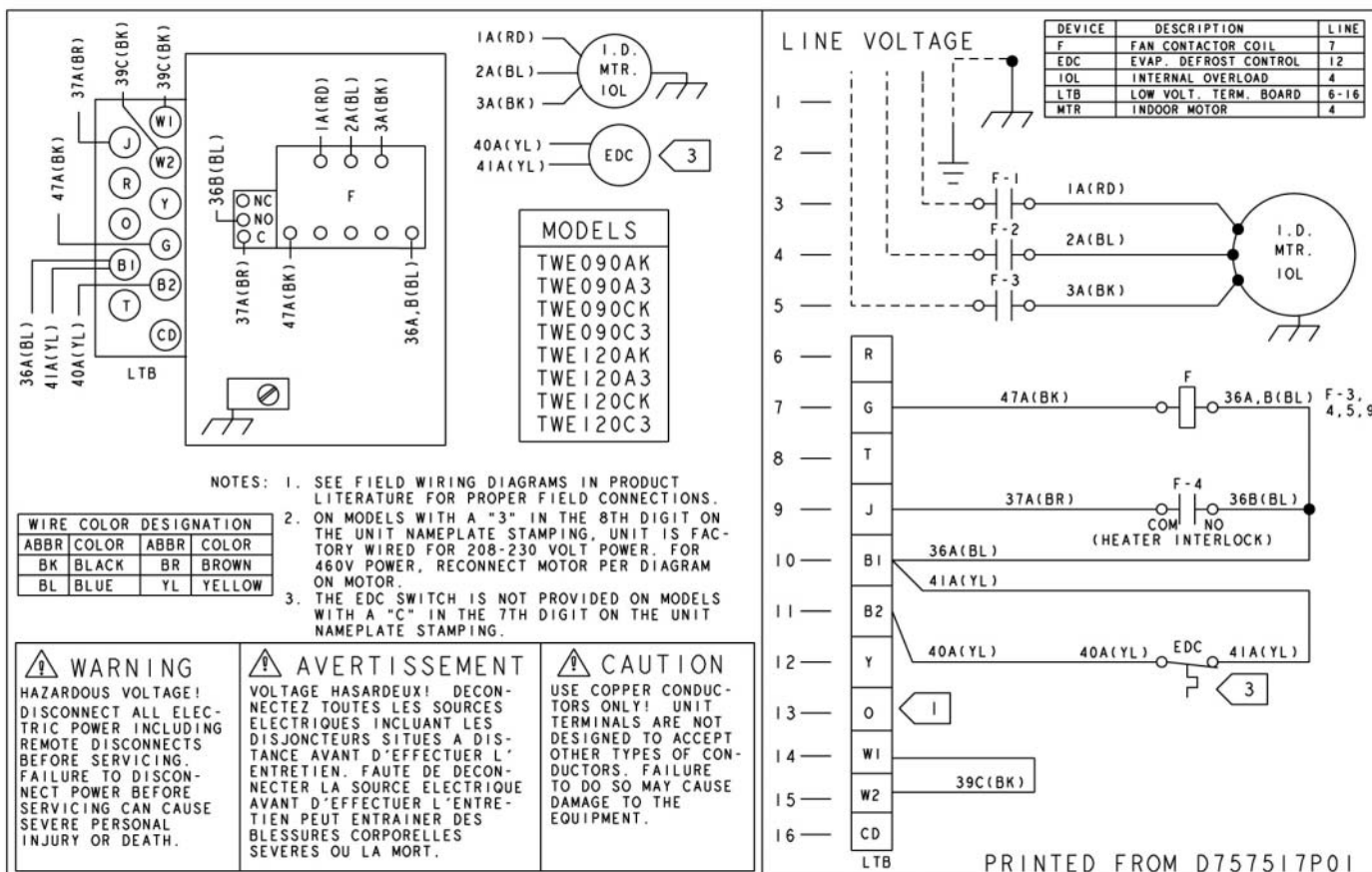

Typical Wiring Condensing Unit

Condensing Unit – Single Compressor

Typical unit wiring diagram. For specific wiring, see individual Service Facts.

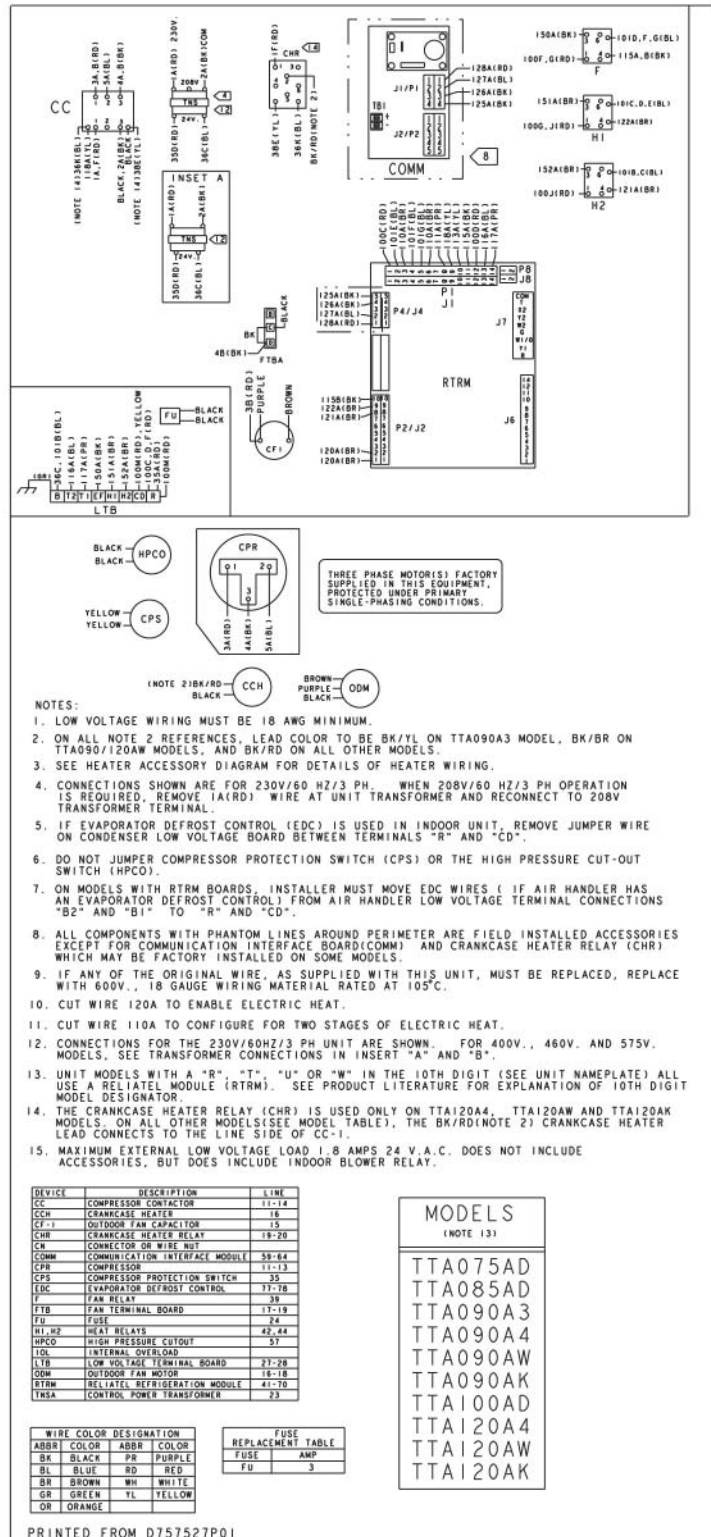

Typical Wiring Condensing Unit

Condensing Unit – Single Compressor

Typical unit wiring diagram. For specific wiring, see individual Service Facts.

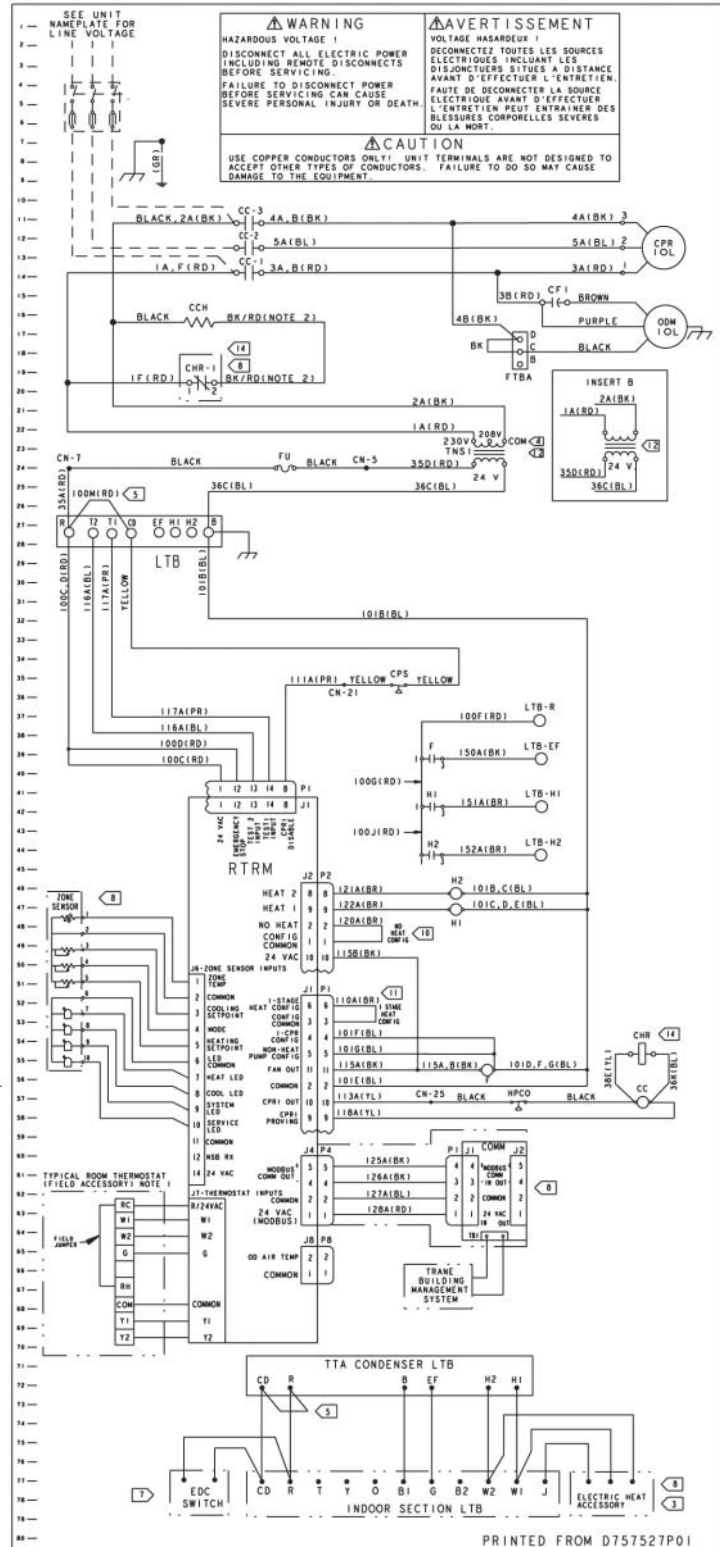

Typical Wiring Condensing Unit

Condensing Unit – Dual Compressor

Typical unit wiring diagram. For specific wiring, see individual Service Facts.

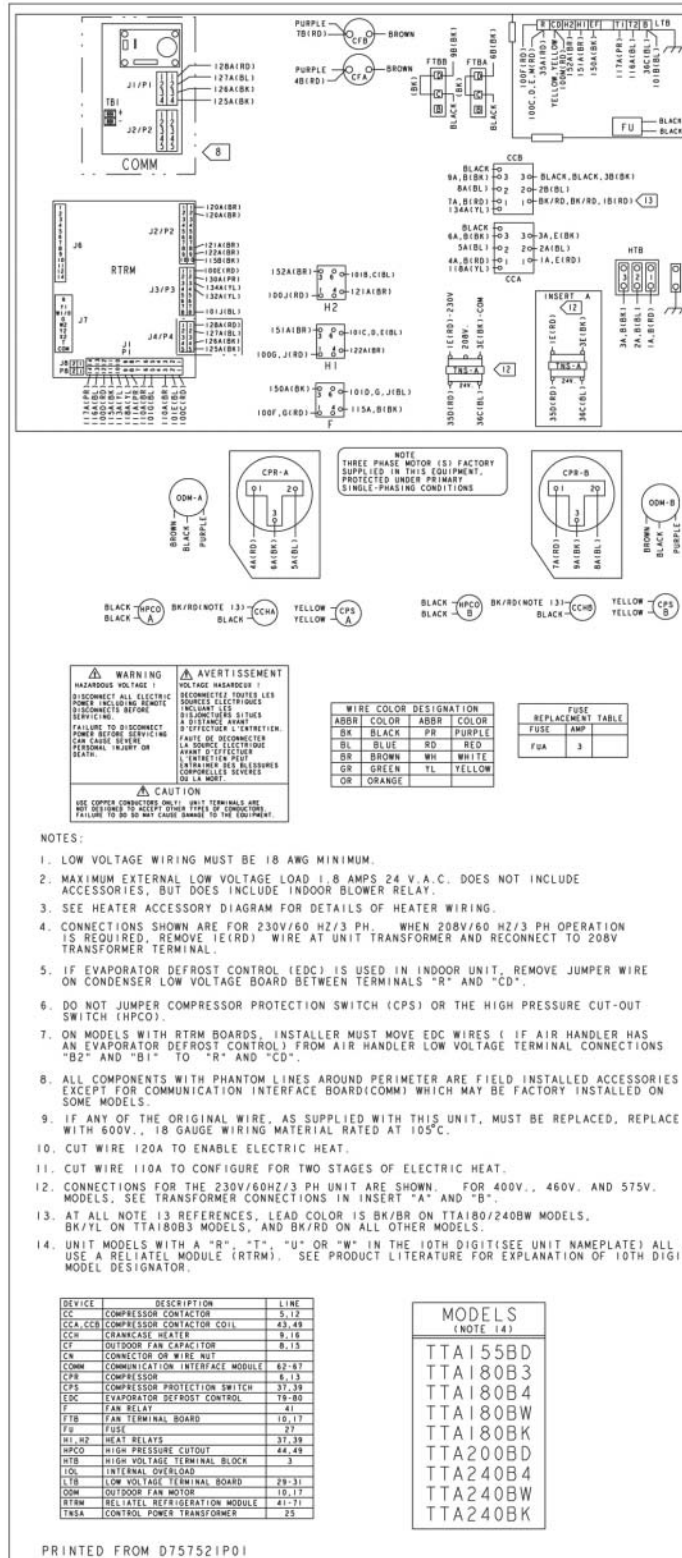

Dimensional Data

7 1/2 Ton

Figure DD-1 – 7½ Ton TTA090A Condensing Unit

All dimensions are in inches (millimeters).

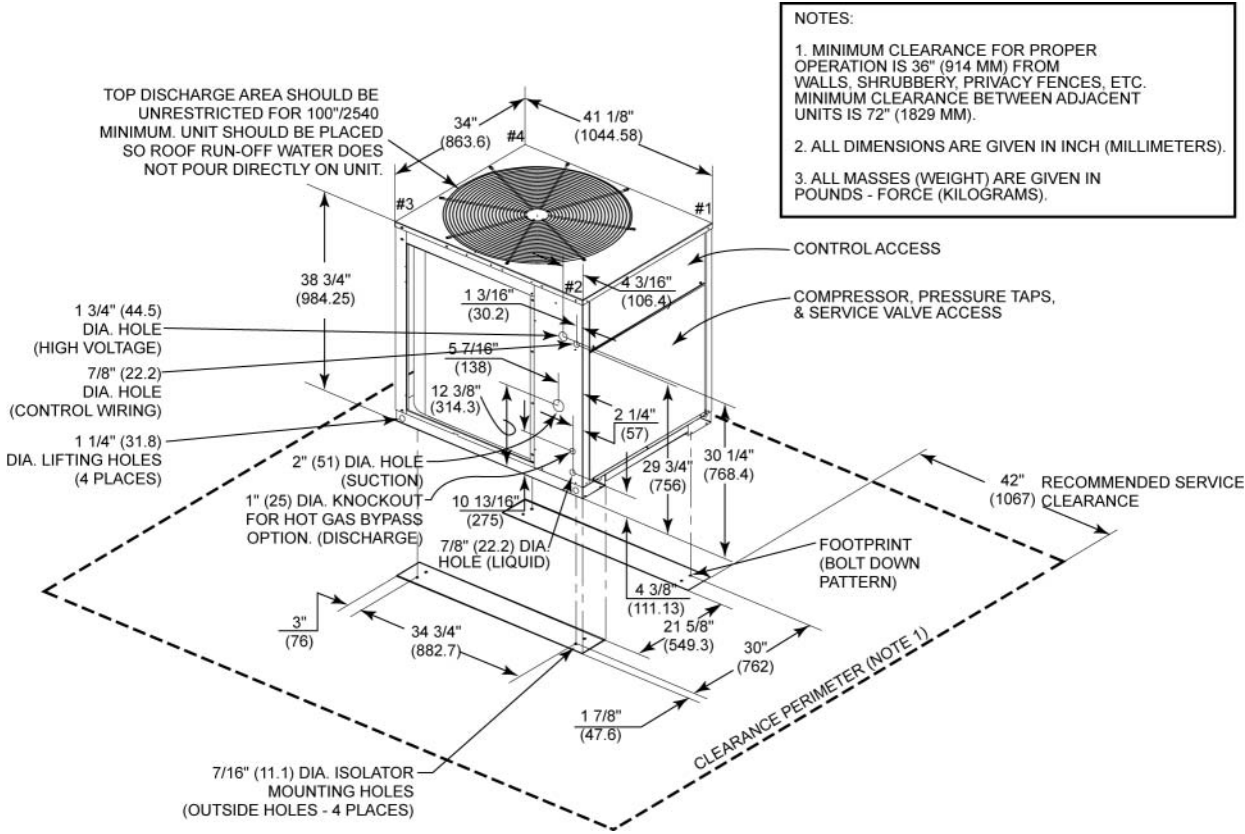

PRODUCT DATA

American Standard Inc.

Dimensional Data 10 Ton

Figure DD-2 – 10 Ton TTA120A Condensing Unit

All dimensions are in inches (millimeters).

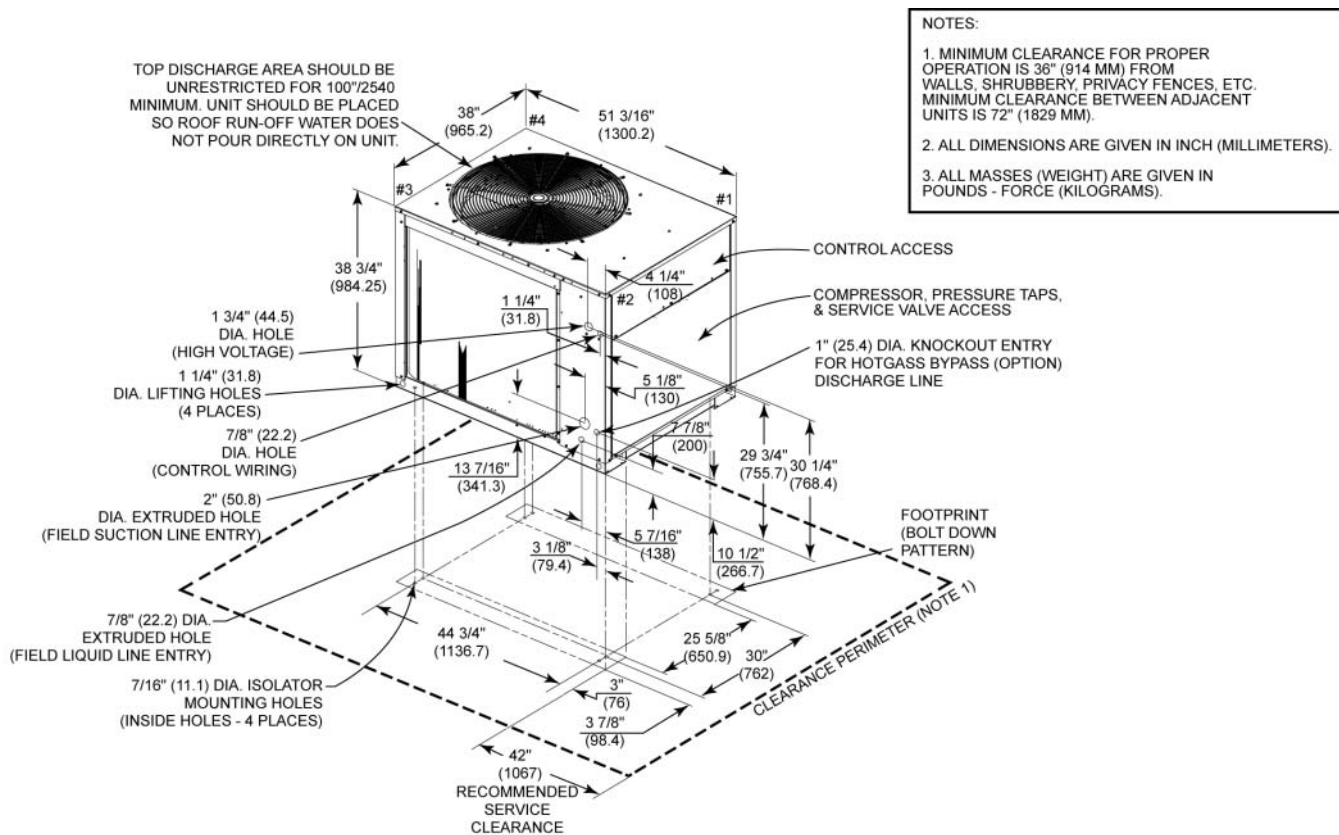

Dimensional Data

10 Ton

Figure DD-3 – 10 Ton TTA120C Condensing Unit

All dimensions are in inches (millimeters).

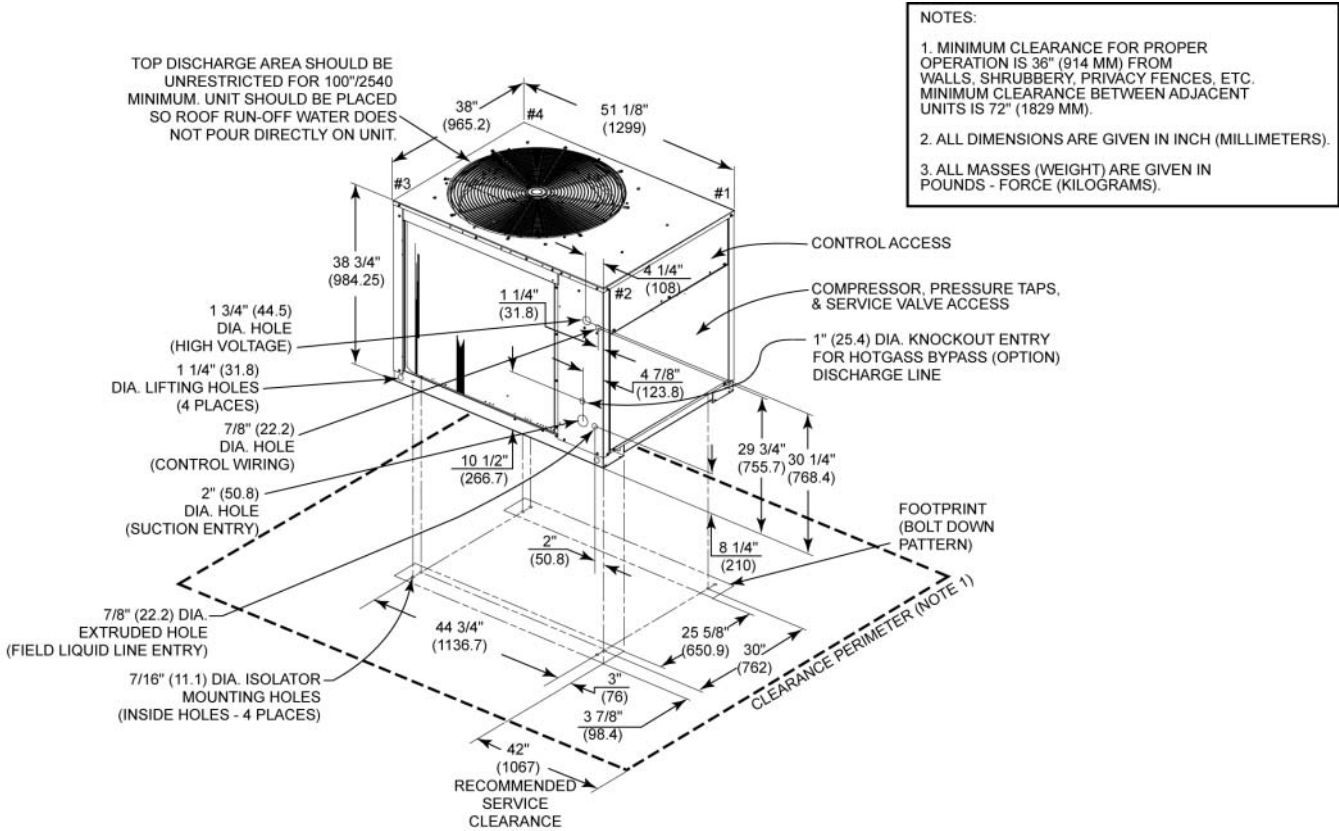

PRODUCT DATA

American Standard Inc.

Dimensional Data 10, 12 1/2 Ton

Figure DD-4 – 10 and 12 1/2 Ton TTA120B and TTA150B Condensing Units

All dimensions are in inches (millimeters).

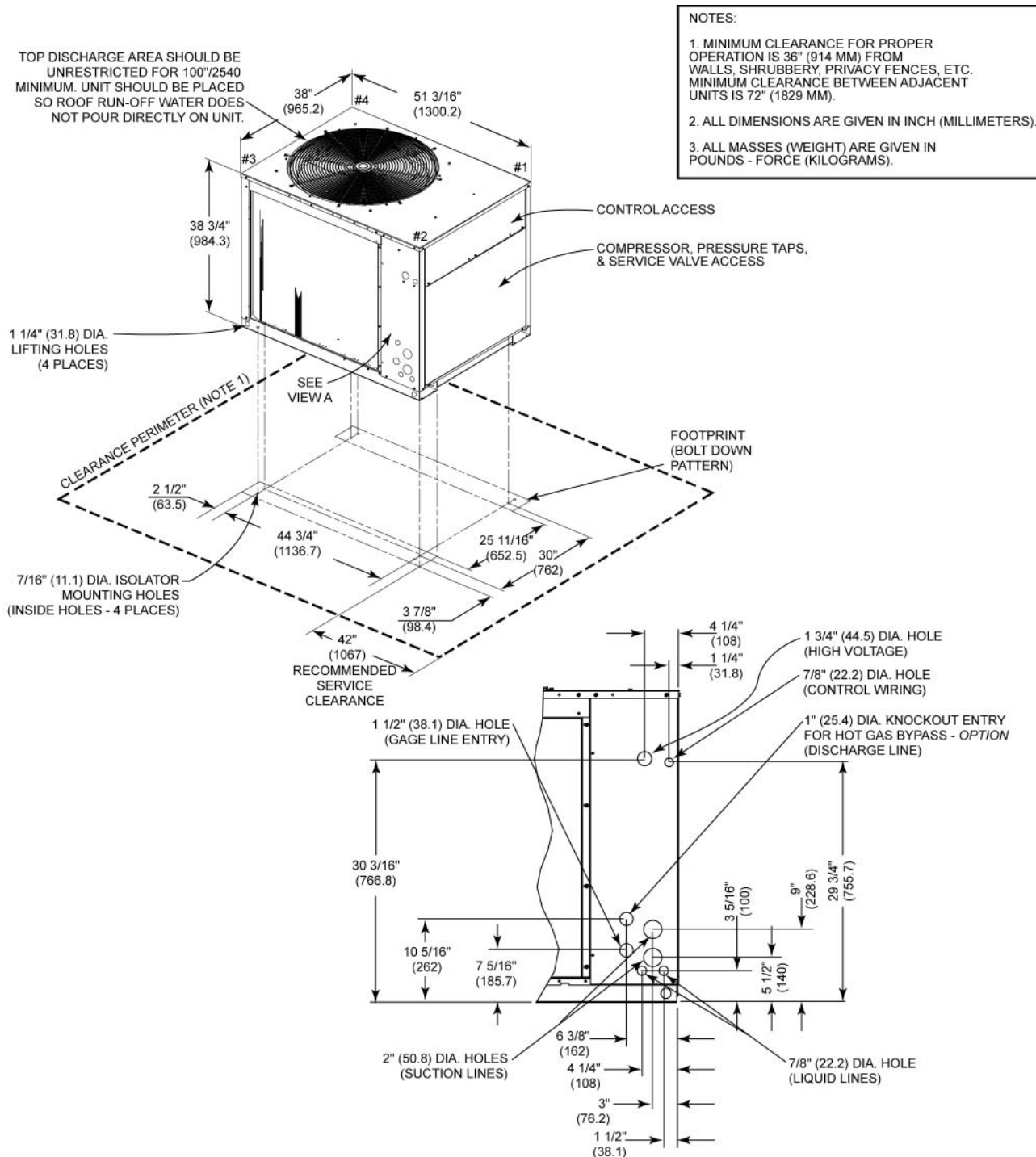

Dimensional Data

15 Ton

Figure DD-5 – 15 Ton TTA180B Condensing Unit

All dimensions are in inches (millimeters).

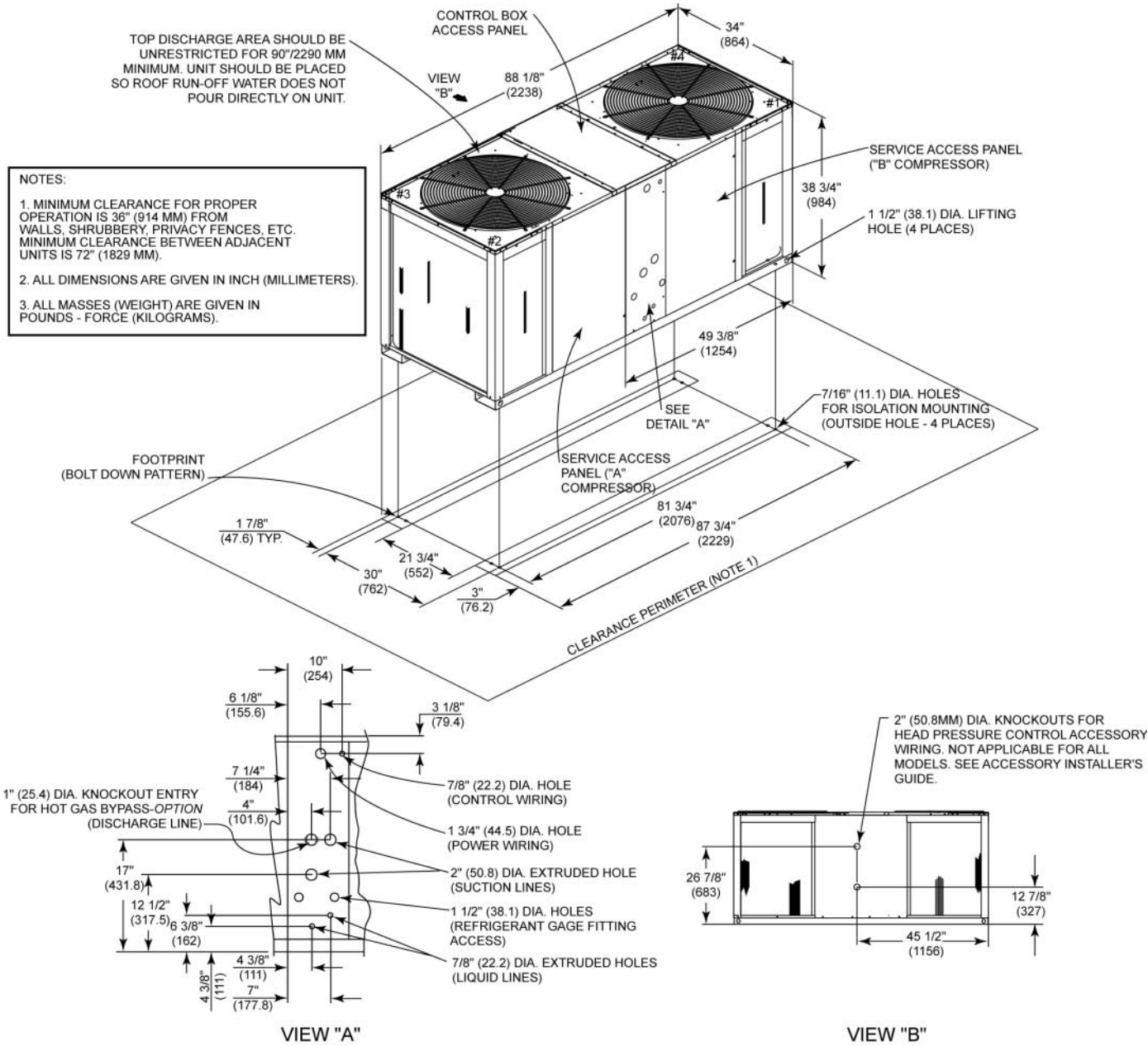

PRODUCT DATA

American Standard Inc.

Dimensional Data 15 Ton

Figure DD-6 – 15 Ton TTA180C Condensing Unit

All dimensions are in inches (millimeters).

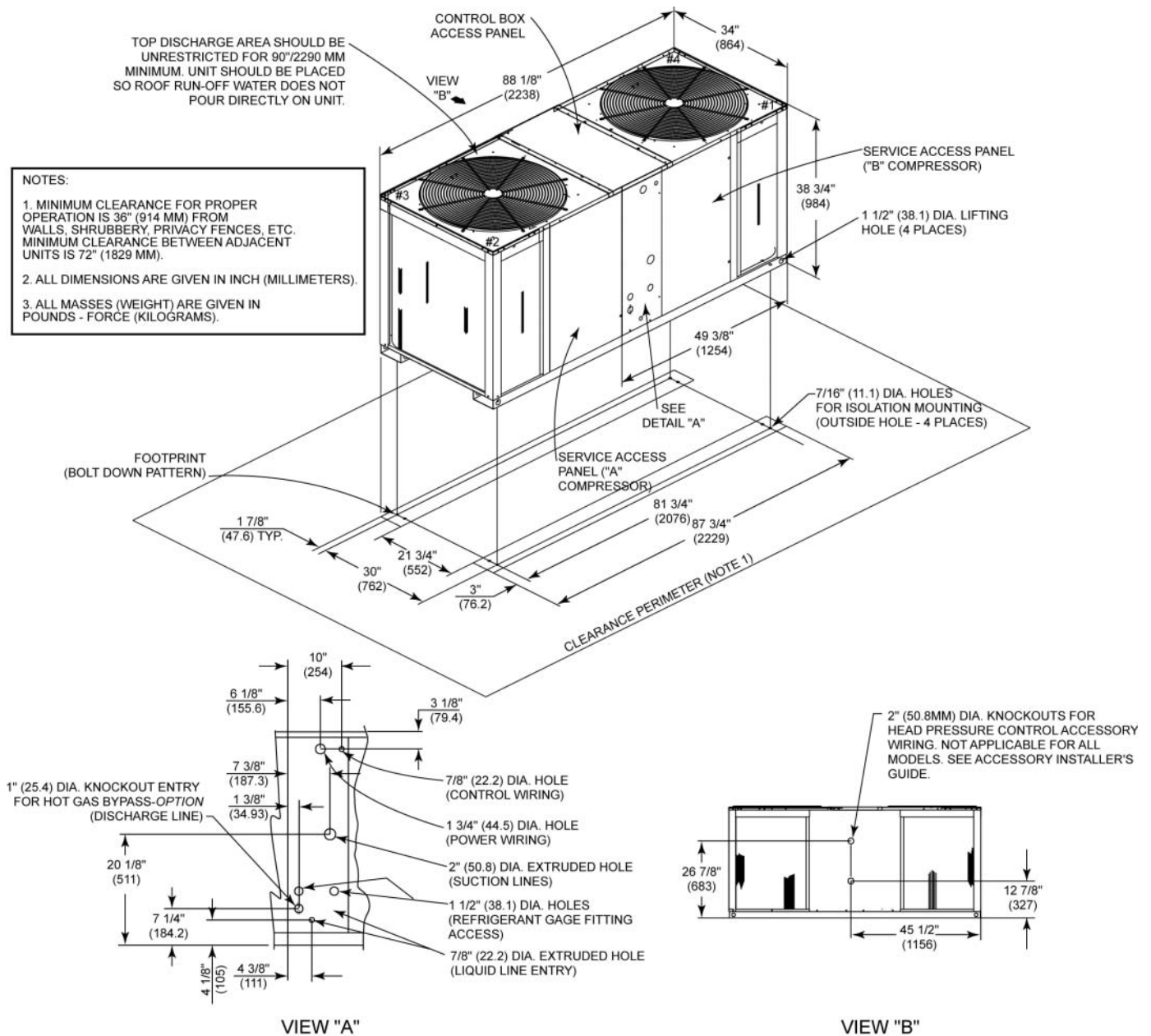

Dimensional Data

20 Ton

Figure DD-7 – 20 Ton TTA240B Condensing Unit

All dimensions are in inches (millimeters).

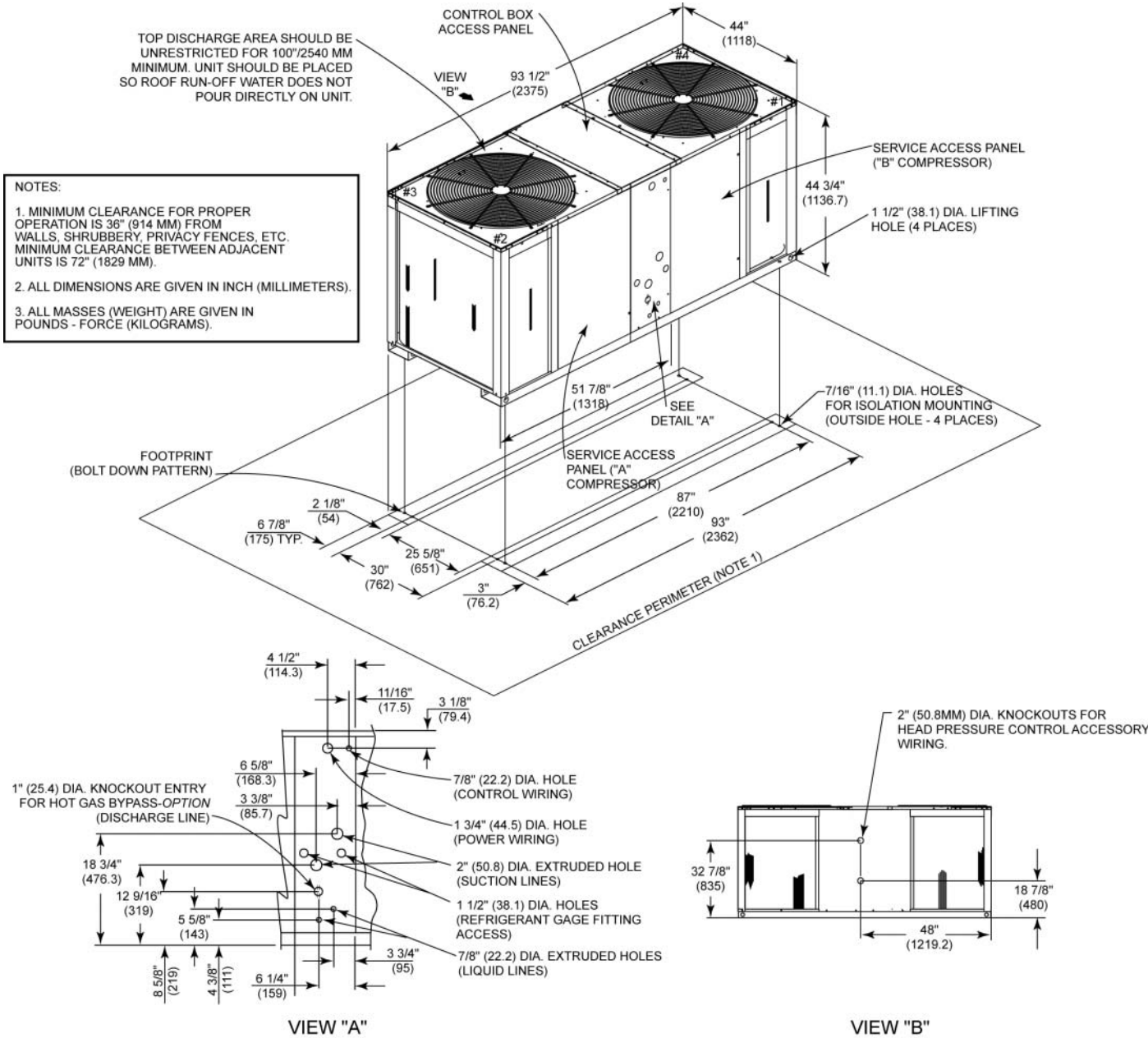

PRODUCT DATA

American Standard Inc.

Dimensional Data 5 Ton

Figure DD-8 – 5 Ton TWE060A, 060B Air Handlers

All dimensions are in inches (millimeters).

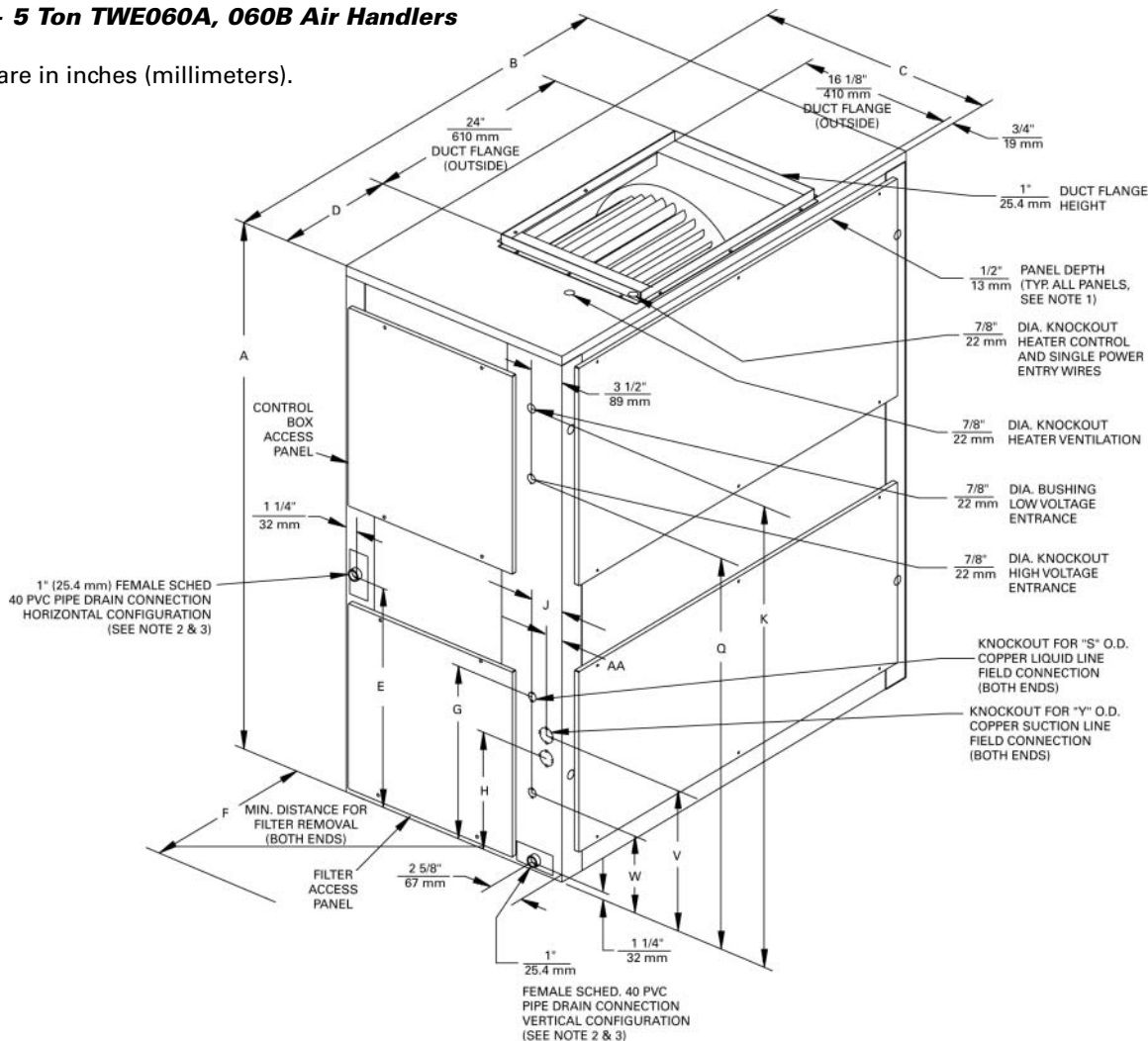

NOTE:

1. LENGTH, WIDTH, AND HEIGHT DIMENSIONS DO NOT INCLUDE 1/2" ACCESS PANEL DEPTH.
2. REMOVABLE DRAIN PAN AND ATTACHED DRAIN CONNECTION MAY BE INSTALLED ON EITHER END OF UNIT IN EITHER THE VERTICAL OR HORIZONTAL CONFIGURATION. PLASTIC DRAIN PAN ACCESS PLATE ON THE END OF UNIT OPPOSITE DRAIN CONNECTION MUST BE REMOVED TO SLIDE DRAIN PAN OUT OF UNIT FOR CLEANING. ACCESS PLATE MUST BE RE-INSTALLED AFTER SLIDING DRAIN PAN BACK INTO UNIT.
3. IF PERIODIC DRAIN PAN CLEANING IS REQUIRED, ALLOW ROOM FOR PARTIAL REMOVAL OF PAN OR DRAIN CONNECTION END OF UNIT.

Table DD-1 – Air Handler Dimensions (in.)

Tons	Model No.	A	B	C	D	E	F	G	H
5	TWE060A	48	38	22	8	19-1/2	26	15-7/8	14-1/8
5	TWE060B	48	38	22	8	19-1/2	26	16-1/4	13-1/4

Table DD-1 – (Continued)

Tons	Model No.	J	K	Q	S	V	W	Y	AA
5	TWE060A	1-7/8	42-1/8	34-5/8	3/8	—	—	1-1/8	1-7/8
5	TWE060B	1-1/8	42-1/8	34-5/8	5/16	14-3/4	11-1/8	3/4	2

Dimensional Data

7 1/2, 10 Ton

Figure DD-9 – 7 1/2 & 10 Ton TWE090A, 120A; TWE 090B, 120B Air Handlers

All dimensions are in inches (millimeters).

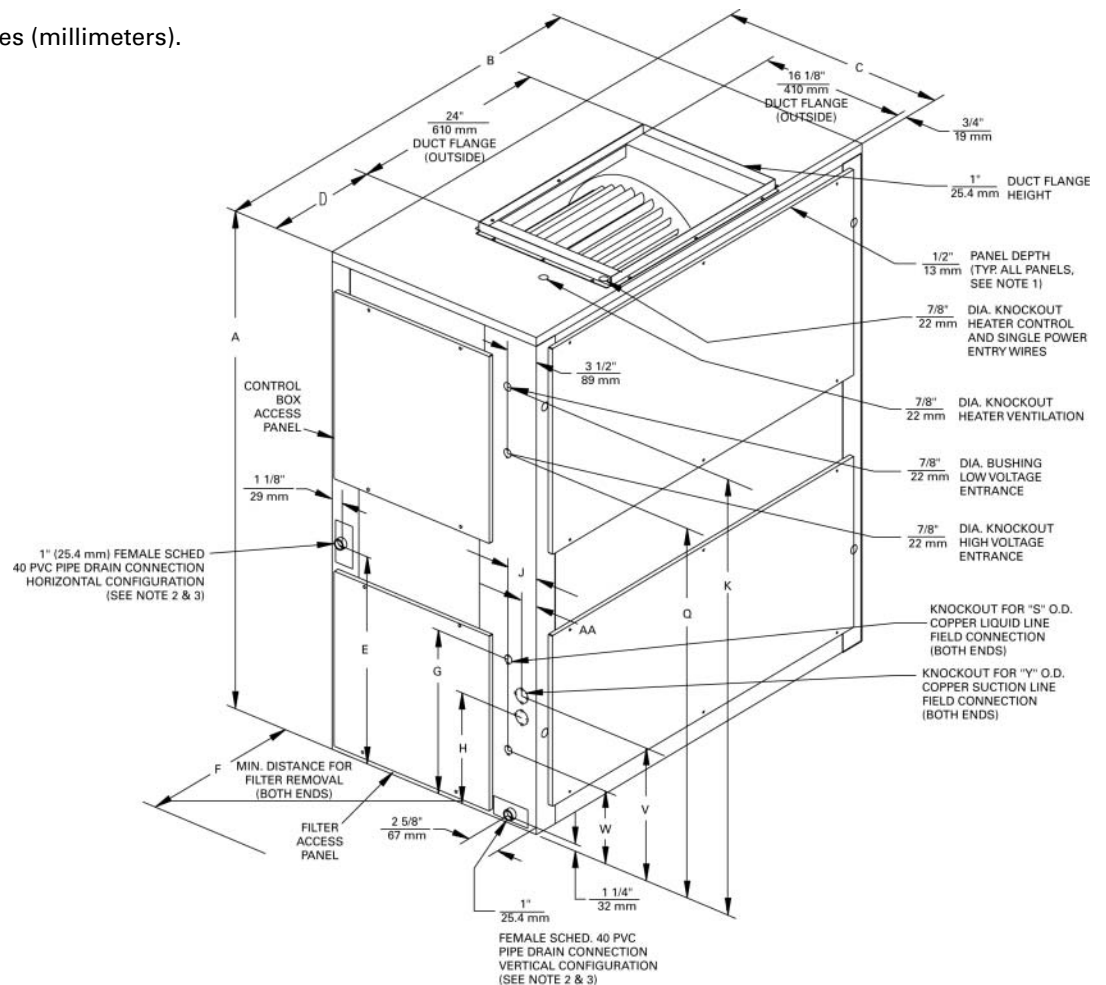

NOTE:

1. LENGTH, WIDTH, AND HEIGHT DIMENSIONS DO NOT INCLUDE 1/2" ACCESS PANEL DEPTH.
2. REMOVABLE DRAIN PAN AND ATTACHED DRAIN CONNECTION MAY BE INSTALLED ON EITHER END OF UNIT IN EITHER THE VERTICAL OR HORIZONTAL CONFIGURATION. PLASTIC DRAIN PAN ACCESS PLATE ON THE END OF UNIT OPPOSITE DRAIN CONNECTION MUST BE REMOVED TO SLIDE DRAIN PAN OUT OF UNIT FOR CLEANING. ACCESS PLATE MUST BE RE-INSTALLED AFTER SLIDING DRAIN PAN BACK INTO UNIT.
3. IF PERIODIC DRAIN PAN CLEANING IS REQUIRED, ALLOW ROOM FOR PARTIAL REMOVAL OF PAN OR DRAIN CONNECTION END OF UNIT.

Table DD-2 – Air Handler Dimensions (in.)

Tons	Model No.	A	B	C	D	E	F	G	H
7 1/2	TWE090A	54	47-1/2	25	11-3/4	22-3/8	22	—	17-3/4
7 1/2	TWE090B	54	47-1/2	25	11-3/4	22-3/8	22	20-1/8	16
10	TWE120A	54	63-12	25	19-3/4	22-3/8	22	—	17-3/4
10	TWE120B	54	63-1/2	25	19-3/4	22-3/8	22	20-1/8	16

Table DD-2 – (Continued)

Tons	Model No.	J	K	Q	S	V	W	Y	AA
7 1/2	TWE090A	4	45-1/4	38-1/8	1/2	—	15	1-3/8	2
7 1/2	TWE090B	2-1/8	45-1/4	38-1/8	3/8	18-3/4	14	1-1/8	2-1/8
10	TWE120A	4	45-1/4	38-1/8	1/2	—	15	1-3/8	2
10	TWE120B	2-1/8	45-1/4	38-1/8	3/8	18-3/4	14	1-1/8	2-1/8

PRODUCT DATA

American Standard Inc.

Dimensional Data 5 - 10 Ton

Figure DD-10 – 5 - 10Ton TWE060A,090A,120A; TWE060B,090B,120B Air Handlers

All dimensions are in inches (millimeters).

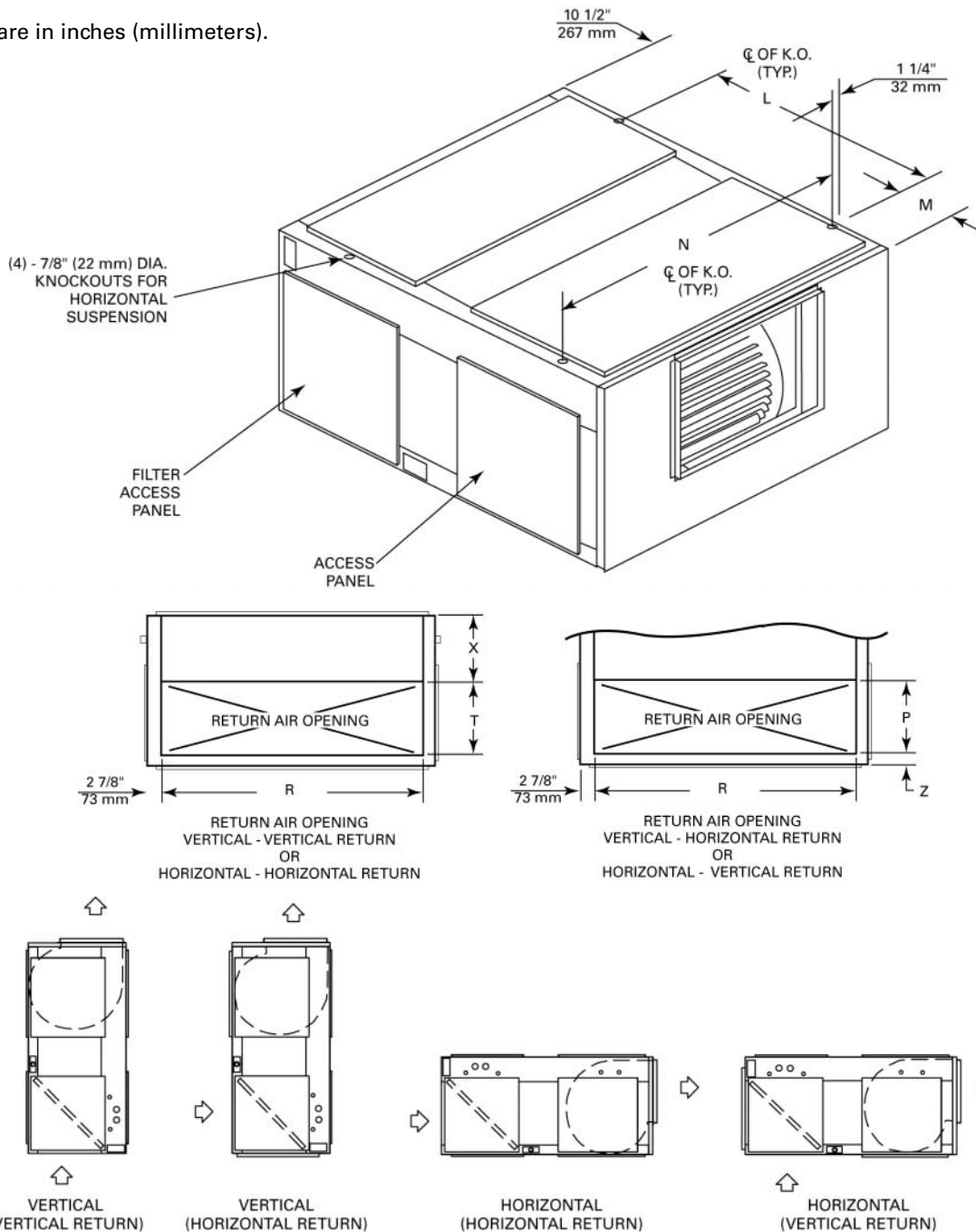

Table DD-3 – Air Handler Dimensions (in.)

Tons	Model No.	L	M	N	P	R	T	X	Z
5	TWE060A,060B	34-5/8	2 7/8	35-5/8	12 1/4	32-1/4	12 1/2	7 5/8	2
7 1/2	TWE090A, 090B	36-7/8	6 5/8	45-1/8	16-1/8	41-3/4	16-1/4	6 7/8	1 3/4
10	TWE120A, 120B	36-7/8	6 5/8	61-1/8	16-1/8	57-3/4	16-1/4	6 7/8	1 3/4

Dimensional Data

15, 20 Ton

Figure DD-11 – 15 & 20 Ton TWE180 and 240B Air Handlers

All dimensions are in inches (millimeters).

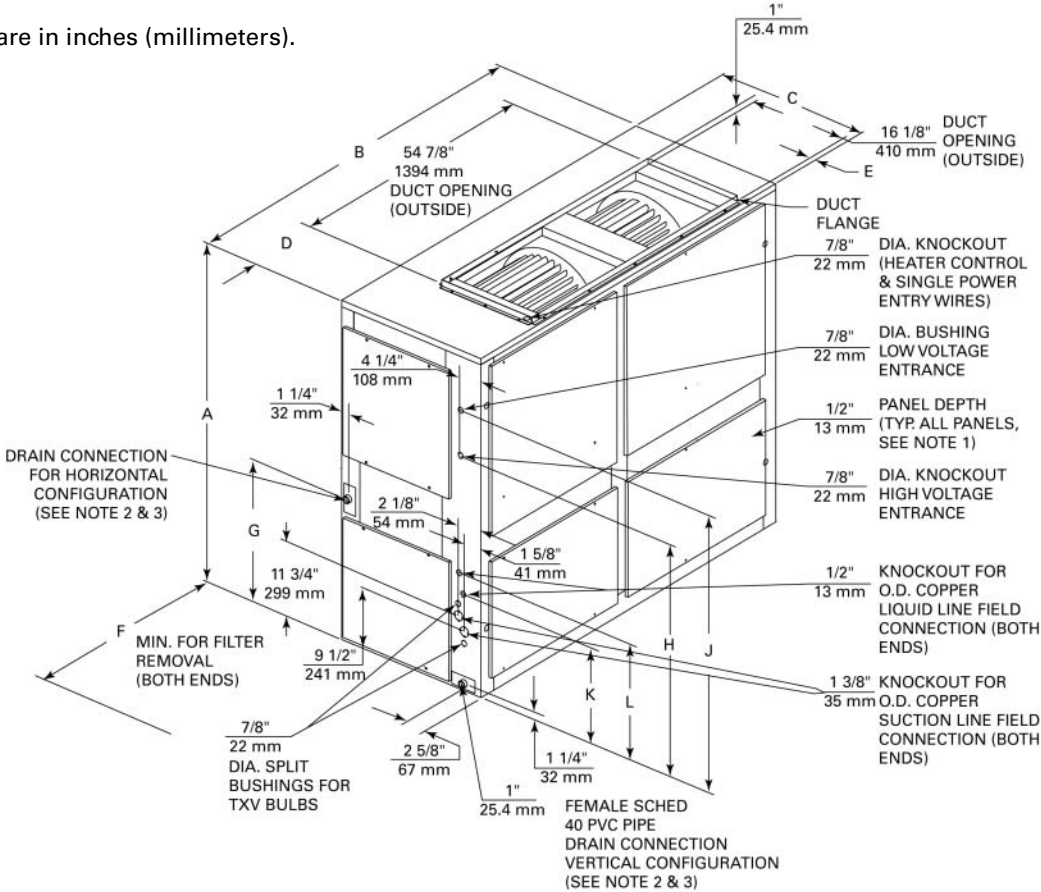

NOTE:

1. LENGTH, WIDTH, AND HEIGHT DIMENSIONS DO NOT INCLUDE 1/2" ACCESS PANEL DEPTH.
2. REMOVABLE DRAIN PAN AND ATTACHED DRAIN CONNECTION MAY BE INSTALLED ON EITHER END OF UNIT IN EITHER THE VERTICAL OR HORIZONTAL CONFIGURATION. PLASTIC DRAIN PAN ACCESS PLATE ON THE END OF UNIT OPPOSITE DRAIN CONNECTION MUST BE REMOVED TO SLIDE DRAIN PAN OUT OF UNIT FOR CLEANING. ACCESS PLATE MUST BE RE-INSTALLED AFTER SLIDING DRAIN PAN BACK INTO UNIT.
3. IF PERIODIC DRAIN PAN CLEANING IS REQUIRED, ALLOW ROOM FOR PARTIAL REMOVAL OF PAN OR DRAIN CONNECTION END OF UNIT.

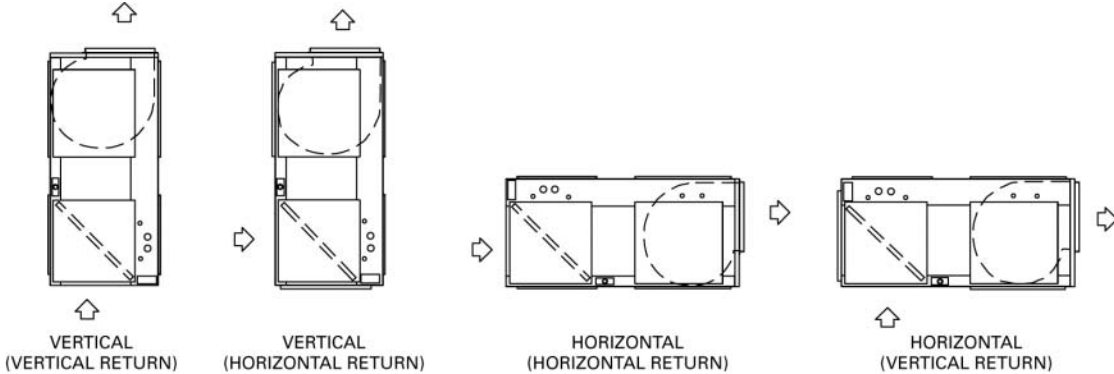

PRODUCT DATA

American Standard Inc.

Dimensional Data 15, 20 Ton

Figure DD-12 – 15 & 20 Ton TWE180 and 240B Air Handlers

All dimensions are in inches (millimeters).

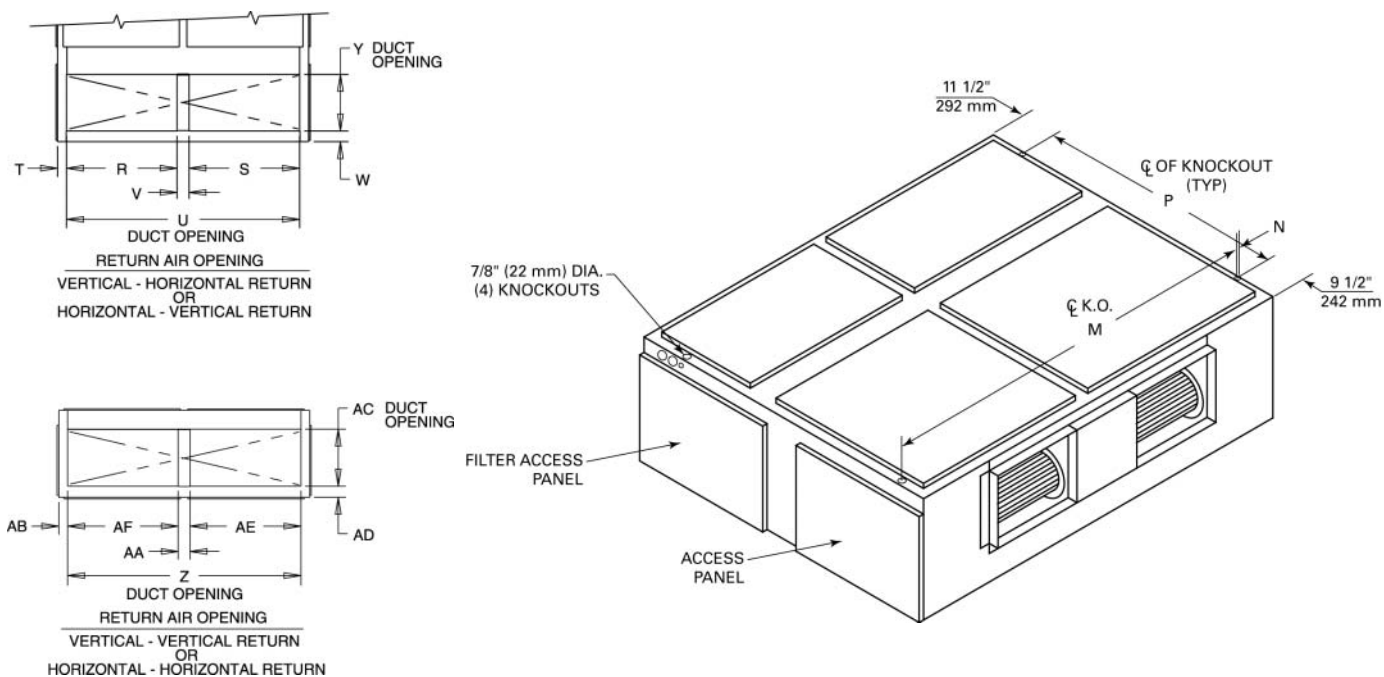

Table DD-4 – Air Handler Dimensions (in.)

Tons	Model No.	A	B	C	D	E	F	G	H	J	K
15	TWE180B	69	79-1/2	27-5/8	12-3/8	1-5/8	26	25-1/8	49-1/8	56-1/4	15-1/2
20	TWE240B	71-7/8	92-1/2	30-1/2	18-7/8	4-1/2	31	28	51-7/8	59-1/8	18-1/8

Table DD-4 – (Continued)

Tons	Model No.	L	M	N	P	R	S	T	U	V	W
15	TWE180B	19-1/2	77-1/4	1 1/4	48	35	35	2-7/8	73-7/8	3-3/4	3-3/8
20	TWE240B	20-7/8	89-1/4	1 3/4	50-7/8	39-1/8	39-1/8	4-7/8	82-7/8	4-5/8	3-1/8

Table DD-4 – (Continued)

Tons	Model No.	Y	Z	AA	AB	AC	AD	AE	AF
15	TWE180B	18	73-7/8	3-3/4	2-7/8	18	3-5/8	35	35
20	TWE240B	20-1/8	82-7/8	4-5/8	4-7/8	20-1/8	3	39-1/8	39-1/8

Dimensional Data

Cooling Coil

Figure DD-13 – 10 Ton TXE120B Cooling Coil.

All dimensions are in inches (millimeters).

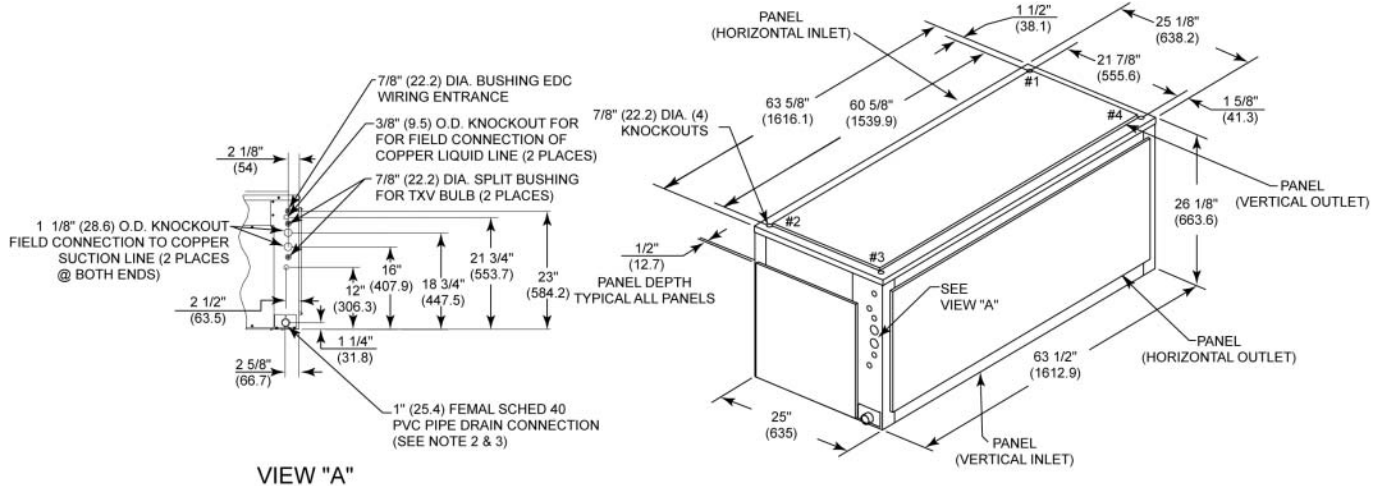

- NOTES:**
1. LENGTH, WIDTH AND HEIGHT DIMENSIONS DO NOT INCLUDE 1/2" ACCESS PANEL DEPTH.
 2. REMOVABLE DRAIN PAN AND ATTACHED DRAIN CONNECTION MAY BE INSTALLED ON EITHER END OF THE UNIT. PLASTIC DRAIN PAN ACCESS PLATE ON THE END OF UNIT OPPOSITE DRAIN CONNECTION MUST BE REMOVED TO SLIDE PAN OUT OF THE UNIT FOR CLEANING. ACCESS PLATE MUST BE RE-INSTALLED AFTER SLIDING DRAIN PAN BACK INTO THE UNIT.
 3. IF PERIODIC DRAIN PAN CLEANING IS REQUIRED, ALLOW ROOM FOR PARTIAL REMOVAL OF PAN ON DRAIN CONNECTION END OF UNIT.

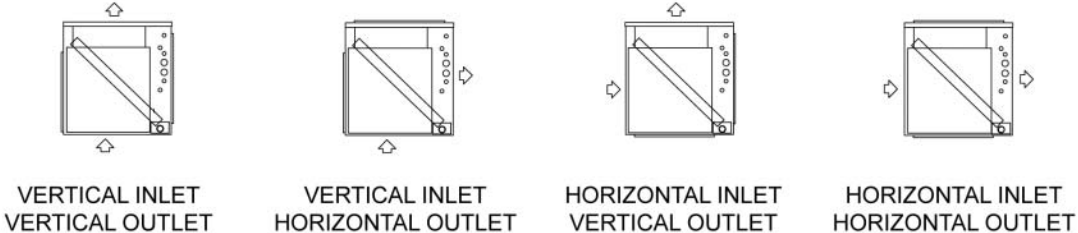
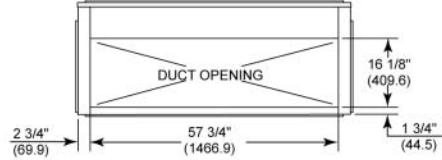
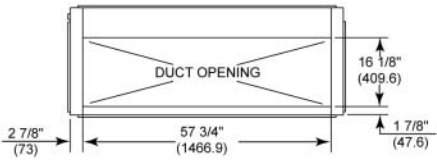
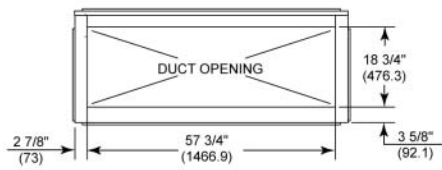
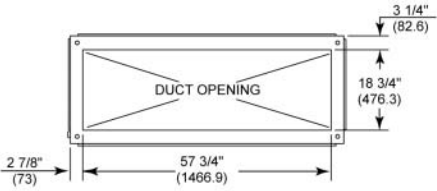

PRODUCT DATA

American Standard Inc.

Dimensional Data Accessories

Figure DD-14— 5 to 20 Ton Isolators.

All dimensions are in inches (millimeters).

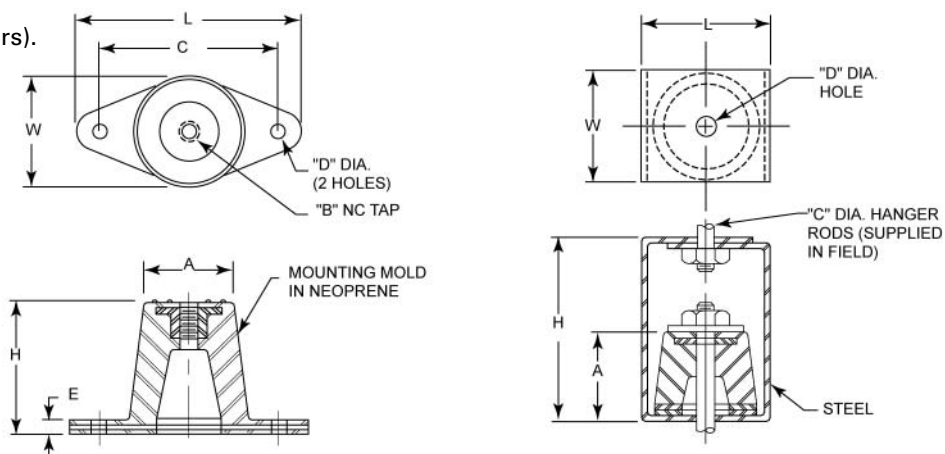

BAYISLT003, 004, 005, 009, 010

BAYISLT012, 013, 014, 015, 016

Table DD-5 – Isolator Dimensions (in.)

Model No.	L	W	H	A	B	C	D	E
BAYISLT003	3-1/8"	1-3/4"	1-1/4"	1-1/4"	3/8"	2-3/8"	3/8"	1/4"
BAYISLT004								
BAYISLT005								
BAYISLT009	3-7/8"	2-3/8"	1-3/4"	1-3/4"	3/8"	3"	3/8"	1/4"
BAYISLT010								
BAYISLT013								
BAYISLT014	2-1/4"	2"	3"	1-3/8"	3/4"	3/8"	1/2"	—
BAYISLT015 ¹								
BAYISLT012								
BAYISLT015 ¹	3"	2-1/4"	4-1/2"	1-7/8"	1/4"	5/8"	3/4"	—
BAYISLT016								

Note:

1 BAYISLT015 contains quantity 2 of the 2-1/4 x 2 x 3 isolators and quantity 3 of the 3 x 2 1/4 x 4 1/2 isolators.

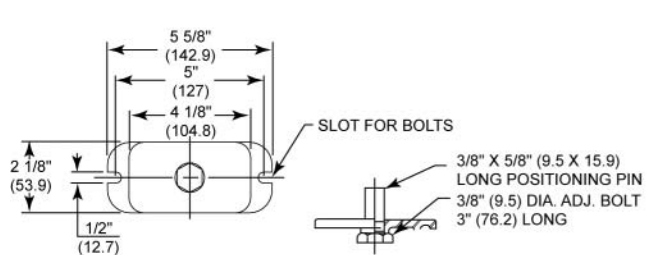

BAYISLT018, 019, 021

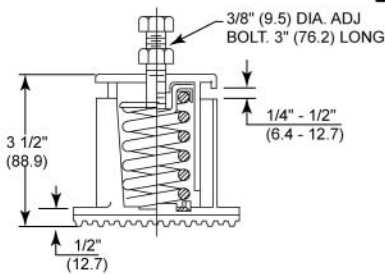

BAYISLT023, 024, 025

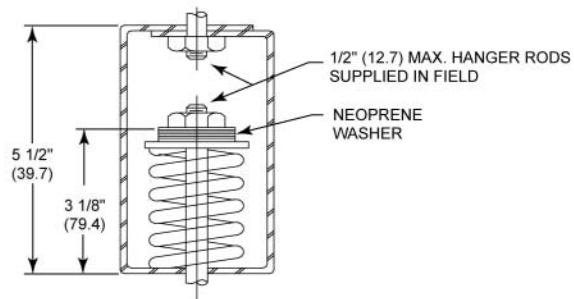
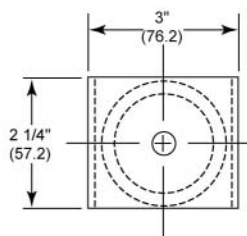

BAYISLT028, 029, 030, 031

Dimensional Data Accessories

Figure DD-15 – Electric Heater for 5, 7 1/2 and 10 Ton Air Handlers

All dimensions are in inches.

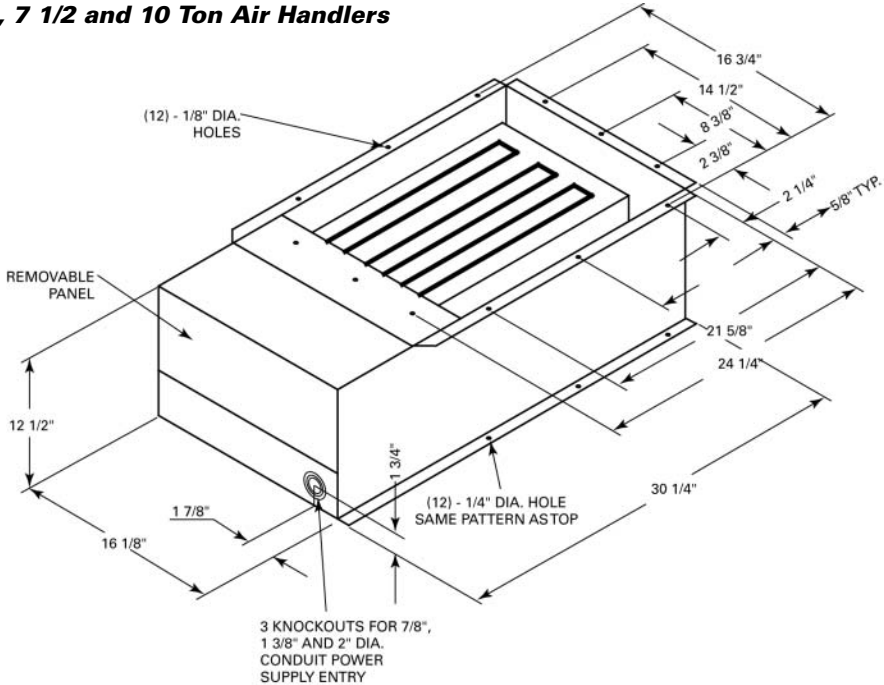
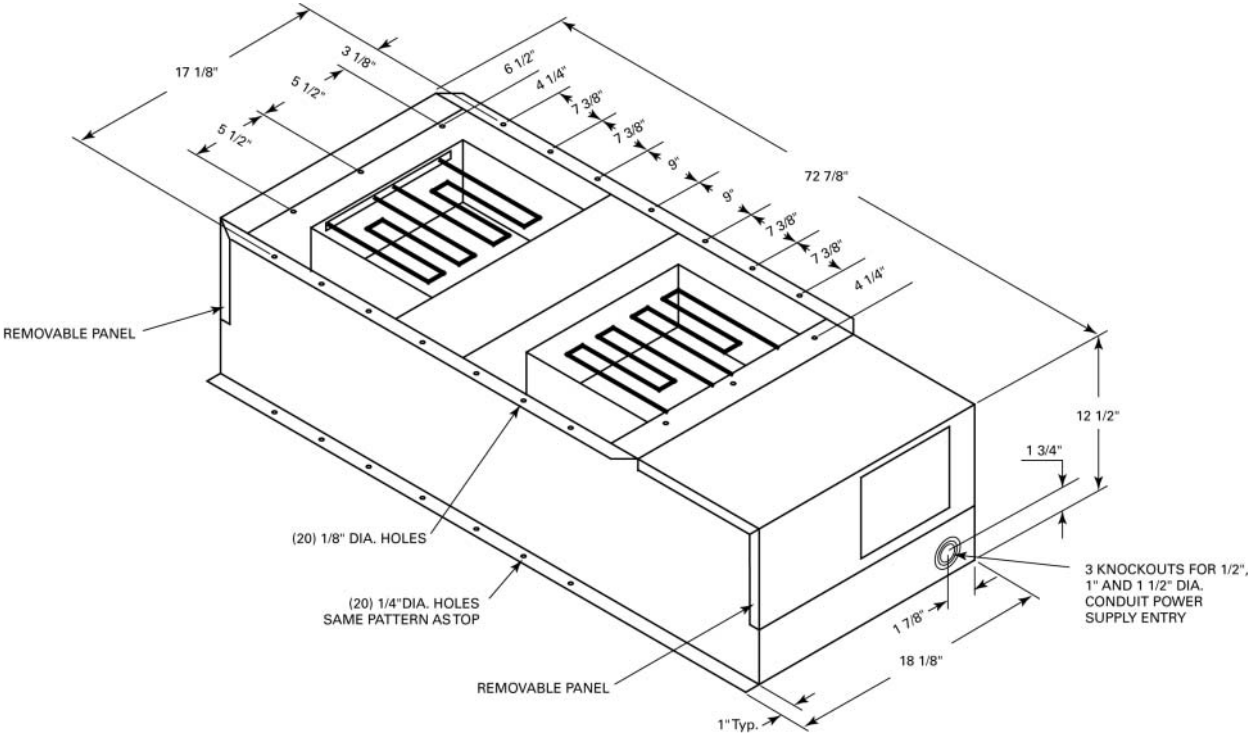

Figure DD-16 – Electric Heater for 15 and 20 Ton Air Handlers

All dimensions are in inches.



PRODUCT DATA

American Standard Inc.

Dimensional Data Accessories

Figure DD-17 – Hot Water Coil

All dimensions are in inches (millimeters).

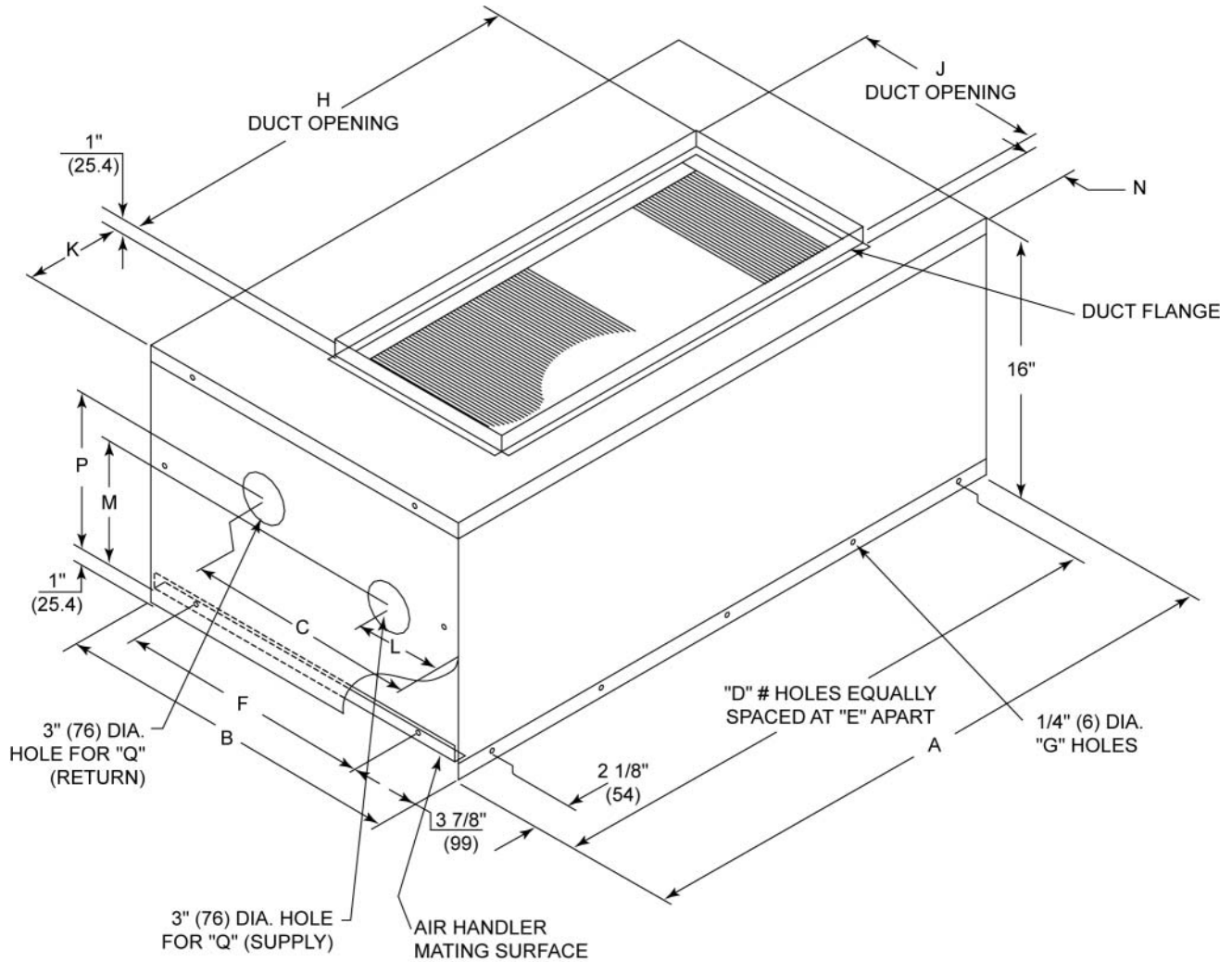

Table DD-6 – Hot Water Coil Dimensions

Tons	Model No.	A	B	C	D	E	F	G	H	J	K	L	M	N	P	Q *
5	BAYWATR017	38 (965)	22 1/8 (562)	13 11/32 (339)	5 (127)	9 (229)	14 (356)	14 (356)	26 (660)	12 (305)	6 (152)	4 11/32 (110)	8 1/4 (210)	2 7/8 (73)	10 1/2 (267)	2 NPT (51) NPT
7 1/2	BAYWATR018	47 5/8 (1210)	25 1/8 (638)	15 19/32 (396)	5 (127)	10 7/8 (276)	17 1/8 (435)	14 (356)	30 (762)	18 (457)	8 7/8 (225)	8 3/32 (206)	10 3/8 (264)	2 7/8 (73)	7 7/8 (200)	2 1/2 NPTI (64) NPTI
10	BAYWATR019	63 5/8 (1616)	25 1/8 (638)	15 19/32 (396)	6 (152)	11 7/8 (302)	17 1/8 (435)	16 (406)	36 (914)	18 (457)	13 7/8 (352)	8 3/32 (206)	10 3/8 (264)	2 7/8 (73)	7 7/8 (200)	2 1/2 NPTI (64) NPTI
15	BAYWATR020	79 5/8 (2022)	27 3/4 (705)	14 7/16 (367)	6 (152)	15 1/8 (384)	19 3/4 (502)	16 (406)	51 (1295)	18 (457)	14 1/4 (362)	6 15/16 (176)	9 1/2 (241)	1 7/8 (48)	7 (178)	2 1/2 NPTI (64) NPTI
20	BAYWATR021	92 5/8 (2353)	30 5/8 (778)	16 3/8 (416)	7 (178)	14 3/4 (375)	22 1/2 (572)	18 (457)	64 (1626)	18 (457)	14 1/4 (362)	8 7/8 (225)	9 1/2 (241)	3 3/4 (95)	7 (178)	2 1/2 NPTI (64) NPTI

*Note internal vs. external pipe threads

Dimensional Data

Accessories

Figure DD-18 – Steam Coil

All dimensions are in inches (millimeters).

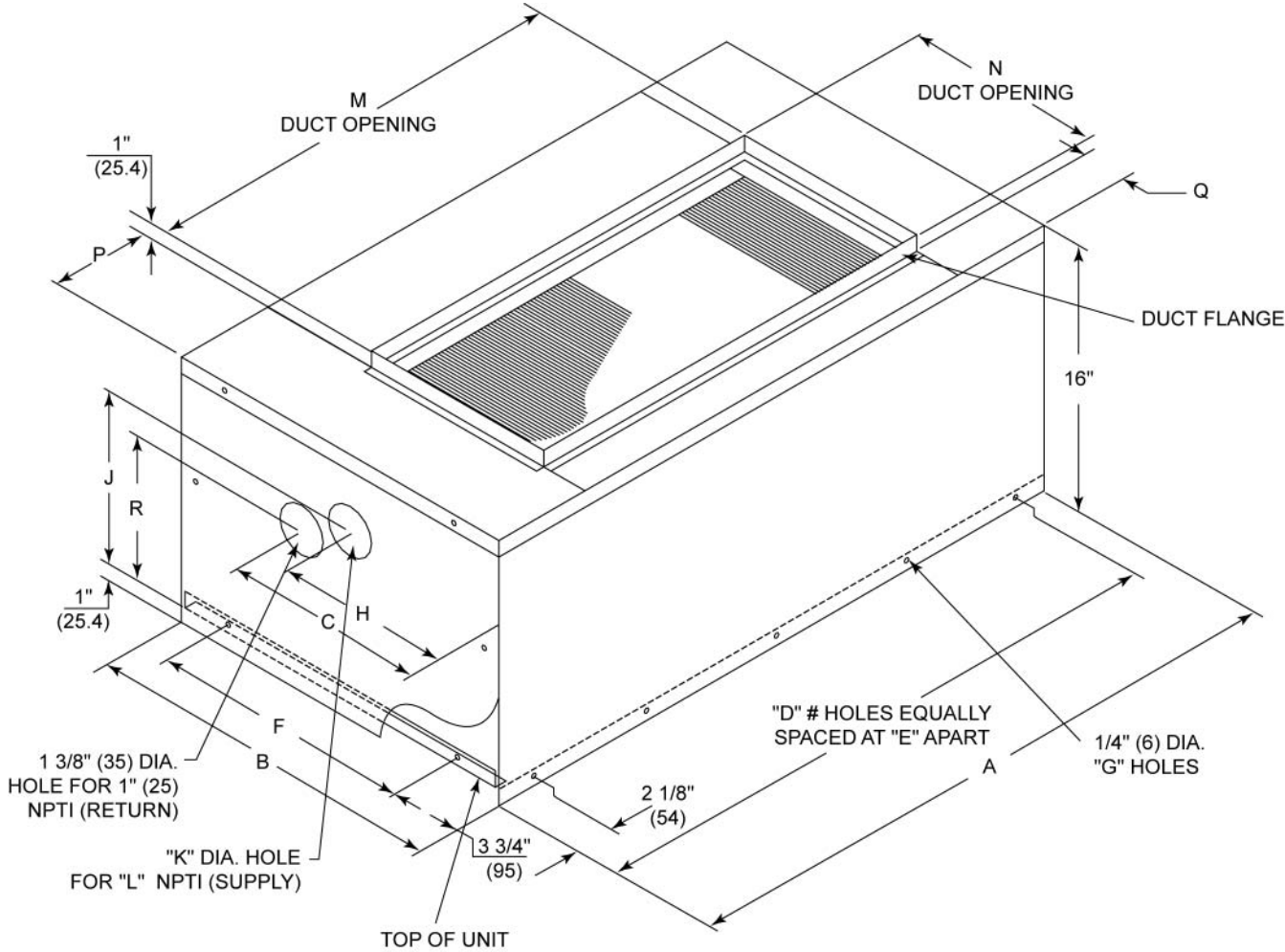

Table DD-7 – Steam Coil Dimensions

Tons	Model No.	A	B	C	D	E	F	G	H	J	K	L	M	N	P	Q	R
5	BAYWATR012	38 (965)	22 1/8 (562)	13 3/4 (349)	5 (127)	9 (229)	14 1/16 (357)	14 (356)	10 3/8 (264)	11 3/8 (289)	2 (51)	1 1/2 (38)	26 (660)	12 (305)	6 (152)	2 7/8 (73)	9 3/4 (248)
7 1/2	BAYWATR013	47 5/8 (1210)	25 3/16 (640)	19 3/4 (502)	5 (127)	10 7/8 (276)	17 1/8 (435)	14 (356)	13 3/8 (340)	11 3/8 (289)	2 1/2 (64)	2 (51)	30 (762)	18 (457)	8 7/8 (225)	2 7/8 (73)	9 3/4 (248)
10	BAYWATR014	63 5/8 (1616)	25 3/16 (640)	19 3/4 (502)	6 (152)	11 7/8 (302)	17 1/8 (435)	16 (406)	13 3/8 (340)	11 1/8 (283)	2 1/2 (64)	2 (51)	36 (914)	18 (457)	13 7/8 (352)	2 7/8 (73)	9 3/4 (248)
15	BAYWATR015	79 5/8 (2022)	27 3/4 (705)	24 7/8 (632)	6 (152)	15 (381)	19 3/4 (502)	16 (406)	18 1/2 (470)	11 1/8 (283)	2 1/2 (64)	2 (51)	51 (1295)	18 (457)	14 1/8 (359)	1 7/8 (48)	9 3/4 (248)
20	BAYWATR016	92 5/8 (2353)	30 5/8 (778)	25 7/8 (657)	7 (178)	14 3/4 (375)	22 1/2 (572)	18 (457)	19 1/2 (495)	12 (305)	2 1/2 (64)	2 (51)	64 (1626)	18 (457)	14 1/8 (359)	3 3/4 (95)	10 7/8 (276)

PRODUCT DATA

American Standard Inc.

Dimensional Data Accessories

Figure DD-19 – Discharge Plenum and Grille

Table DD8 – Discharge Plenum and Grille Dimensions (in.) - No Heat

Tons	Model No.	A	B	C
5	BAYPLNM015	37-15/16	21-15/16	28
7½	BAYPLNM016	47-1/2	25	28
10	BAYPLNM017	63-1/2	25	28

Table DD9 – Discharge Plenum and Grille Dimensions (in.) For Use w/ Electric Heat

Tons	Model No.	A	B	C
5	BAYPLNM025	37-15/16	21-15/16	29
7½	BAYPLNM026	47-1/2	25	29
10	BAYPLNM027	63-1/2	25	29
15	BAYPLNM028	79-1/2	27-11/16	35
20	BAYPLNM029	92-1/2	30-7/16	35

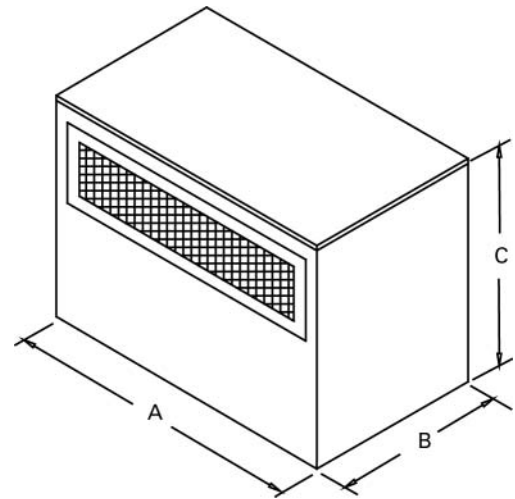

Figure DD-20 – Hydronic Discharge Plenum and Grille

Table DD10 – Hydronic Discharge Plenum and Grille Dimensions (in.)

Tons	Model No.	A	B	C
5	BAYPLNM020	37-7/8	21-7/8	14 3/4
7 1/2	BAYPLNM021	47-1/2	25	14 3/4
10	BAYPLNM022	63-1/2	25	14 3/4
15	BAYPLNM018 ¹	79-1/2	27-11/16	22
20	BAYPLNM019 ¹	92-1/2	30-7/16	24

Note:

1. For use with hydronic heat or no heat.

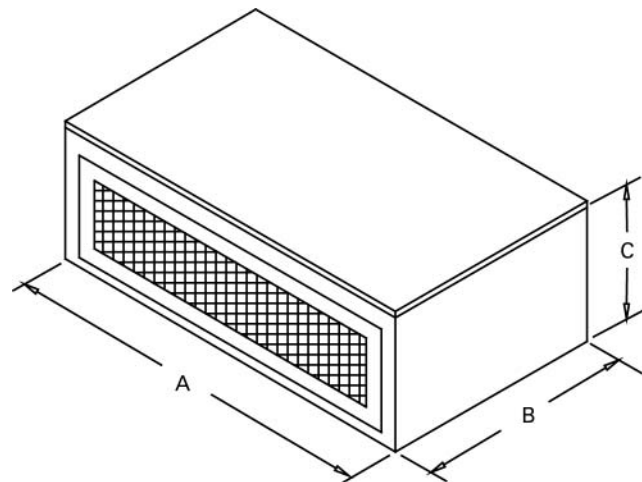

Dimensional Data

Accessories

Figure DD-21 – Subbase

Table DD11 – Subbase Dimensions (in.)

Tons	Model No.	A	B
5	BAYBASE001	38	22
7½	BAYBASE002	47-1/2	25
10	BAYBASE003	63-1/2	25
15	BAYBASE004	79-1/2	27-5/8
20	BAYBASE005	92-1/2	30-7/16

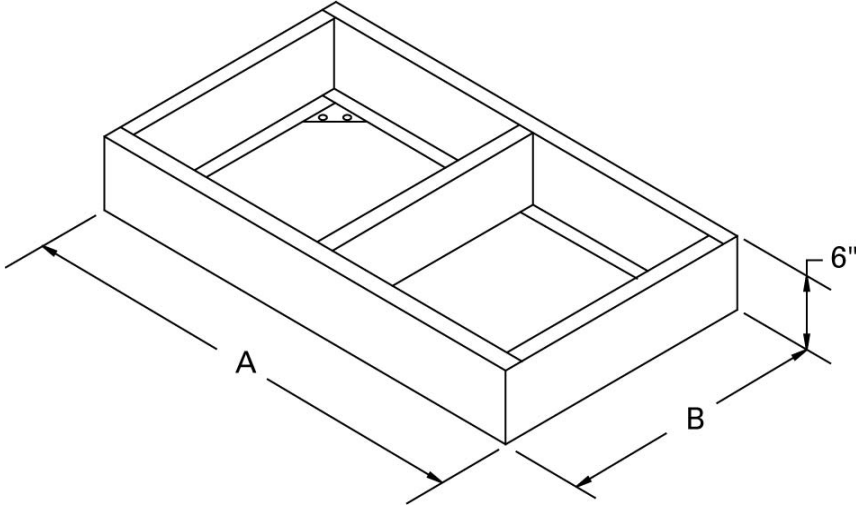

PRODUCT DATA

American Standard Inc.

Weights Condensing Units

Table W-1 – Unit and Corner Weights (lbs.)

Tons	Unit Model No.	Shipping Maximum (lbs)	Net Maximum (lbs)	Corner Weights			
				1	2	3	4
7 1/2	TTA090A	370	326	105	83	61	77
	TTA120A	443	399	149	116	78	100
	TTA120B	481	427	133	135	87	85
10	TTA120C	492	437	139	122	87	95
	TTA150B	481	427	133	135	87	85
12 1/2	TTA180B or C	764	679	196	193	144	146
20	TTA240B	948	863	247	244	185	187

Table W-2 – Accessory Weights (net lbs.)

Tons	Unit Model No.	RIS	Steel Spring	Anti Short	Coil	Low	
		Isolators	Isolators	Cycle Timer	Guard	Thermo-stats	Ambient
7 1/2	TTA090A	2	12	1	8	1	23
10	TTA120A	2	12	1	11	1	23
	TTA120B						
	TTA120C						
12 1/2	TTA150B	2	12	1	20	1	23
15	TTA180B or C	2	12	1	22	1	23
20	TTA240B	2	12	1	34	1	23

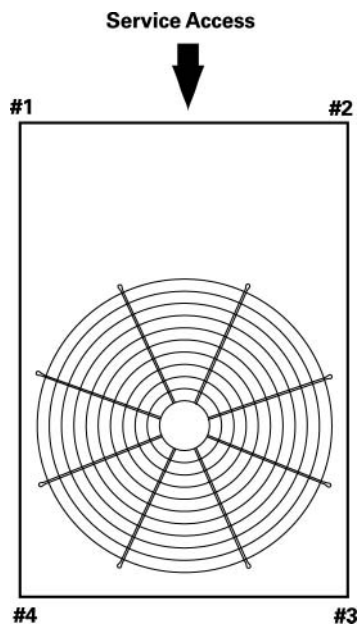

**7 1/2, 10 and 12 1/2 Tons
TTA090A, 120A; TTA120B;
TTA120C; TTA150B**

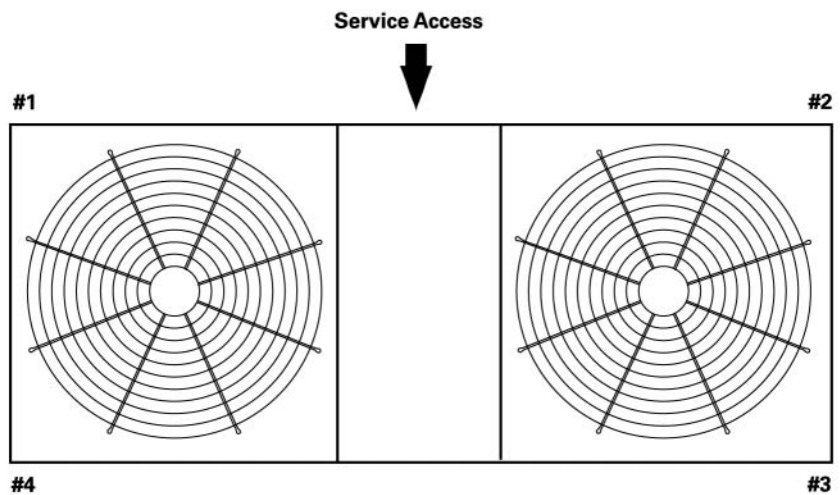

**15 and 20 Ton
TTA180B, 240B; TTA180C**

Weights Air Handlers

Table W-3 – Unit and Corner Weights (lbs.)

Tons	Unit Model No.	Shipping Maximum (lbs)	Net Maximum (lbs)	Corner Weights – Vertical				Corner Weights – Horizontal			
				1	2	3	4	A	B	C	D
5	TWE060A, B	298	232	59	59	59	59	54	64	64	54
7½	TWE090A, B	388	317	79	79	79	79	73	81	84	77
10	TWE120A, B	439	392	98	98	98	98	95	101	101	95
15	TWE180B	754	692	173	173	173	173	156	174	190	170
20	TWE240B	886	816	204	204	204	204	179	221	228	185
10	TXE120B	264	190	-	-	-	-	-	-	-	-

Note:

1 If application requires steam or hot water heating coils, field supplied isolators must be utilized.

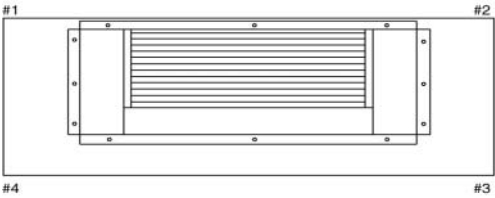

**Vertical - 5, 7 1/2 & 10 Ton
TWE060A, 060B, 090A, 090B, 120A, 120B**

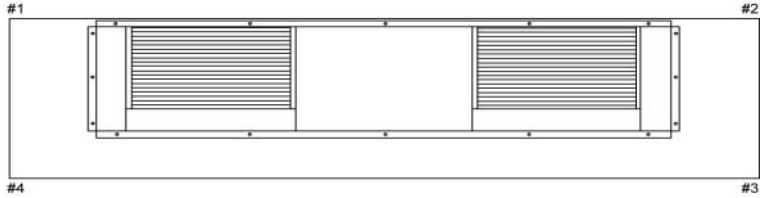

**Vertical - 15 & 20 Ton
TWE180B, 240B**

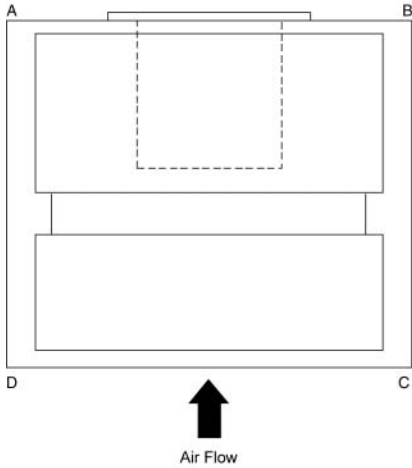

**Horizontal - 5, 7 1/2 & 10 Ton
TWE060A, 060B, 090A, 090B, 120A, 120B**

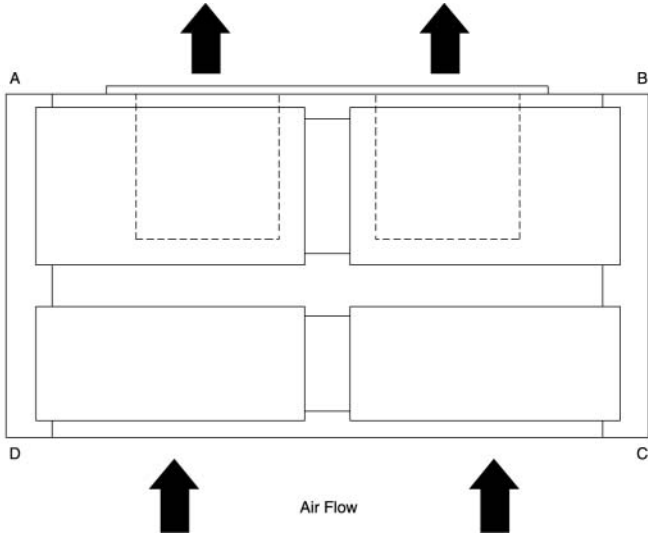

**Horizontal - 15 & 20 Ton
TWE180B, 240B**

PRODUCT DATA

American Standard Inc.

Weights Accessories

Table W-4 – Accessory Weights (net lbs.)

Tons	Unit Model No.	Hot Water Coil	Steam Coil	Discharge Plenum And Grille ¹	Discharge Plenum And Grille ²	Discharge Plenum And Grille ³	Return Air Grille	Electric Heat Min/Max	Subbase	Oversized Motor	RIS Isolator Floor Mount	RIS Isolator Suspended Mount
5	TWE060A,B	82	90	63	58	93	3	32/43	14	31	2	9
7½	TWE090A,B	111	126	78	73	123	5	27/45	19	48	2	6
10	TWE120A,B	159	142	97	92	156	7	27/45	23	50	2	7
15	TWE180B	198	220	—	230	230	10	79/100	27	80	2	7
20	TWE240B	233	251	—	145	264	12	79/100	31	88	2	9

Tons	Unit Model No.	Steel Spring Isolator Floor Mount	Steel Spring Isolator Suspended Mount	Control Transformer
5	TWE060A,B	12	6	—
7½	TWE090A,B	12	6	4
10	TWE120A,B	12	6	4
15	TWE180B	12	6	—
20	TWE240B	12	6	—

Note:

- 1 For use with Hydronic Heat.
- 2 For use when no heat is supplied.
- 3 For use with electric heat.

Mechanical Specifications

Condensing Units

General

Units shall be assembled on sturdy steel mounting/lifting rails and shall be weather proofed. Units shall include hermetic scroll compressors, plate fin condenser coils, fans and motors, controls and holding charge of nitrogen. Operating range shall be between 115°F and 50°F in cooling as standard from the factory. Units shall be UL 1995 listed, certified and rated in accordance with ARI Standard 340/360 or 365.

Casing

Unit casing shall be constructed of zinc coated heavy gauge, galvanized steel. Exterior surfaces shall be cleaned, phosphatized and finished with a weather-resistant baked enamel finish. Units surface shall be tested 500 hours in salt spray test. Units shall have removable end panels which allow access to all major components and controls.

Refrigeration System – Single Compressor

TTA090A, TTA120A units shall have a single refrigeration circuit. Each refrigeration circuit has an integral subcooling circuit. A refrigeration filter drier shall be provided as standard. The TTA090A, TTA120A units shall have both a liquid line and suction gas line service valve with gauge port.

TTA090A, TTA120A units shall have one direct-drive hermetic scroll compressor with centrifugal oil pump providing positive lubrication to moving parts. Motor shall be suction gas-cooled and shall have a voltage utilization range of plus or minus 10 percent of unit nameplate voltage.

Crankcase heater, discharge line thermostat, internal temperature and current-sensitive motor overloads shall be included for maximum protection. Scroll type compressor shall provide inherently low vibration and noise by having no suction and discharge valves. External high and low pres-

sure cutout devices shall be provided. Evaporator defrost control provided in indoor blower coil shall prevent compressor slugging by temporarily interrupting compressor operation when low evaporator coil temperatures are encountered.

Refrigeration System – Dual Compressor

TTA120B, TTA150B, TTA180B, TTA240B units shall have two separate and independent refrigeration circuits. Each refrigeration circuit shall have an integral subcooling circuit. A refrigeration filter drier shall be provided as standard. Units shall have both a liquid line and suction gas line service valve with gauge port.

TTA120B, TTA150B, TTA180B, and TTA240B units shall have two American Standard direct-drive hermetic scroll compressors with centrifugal oil pump and provide positive lubrication to all moving parts. Motor shall be suction gas-cooled and shall have a voltage utilization range of plus or minus 10 percent of nameplate voltage. Crankcase heater, discharge line thermostat, internal temperature and current-sensitive motor overloads shall be included for maximum protection.

Scroll compressor shall provide inherently low vibration and noise by having no suction and discharge valves. External high and low pressure cutout devices shall be provided. Evaporator defrost control provided in indoor blower coil shall prevent compressor slugging by temporarily interrupting compressor operation when low evaporator coil temperatures are encountered.

Refrigeration System – Dual Manifolder Compressors

TTA 120C and TTA180C units shall have a single refrigeration circuit with an integral subcooling circuit. A refrigeration filter drier shall be provided as standard. Units shall have both a liq-

uid line and suction gas line service valve with gauge port.

The units shall have two scroll compressors manifolded together. Motor shall be suction gas-cooled and shall have a voltage utilization range of plus or minus 10 percent of nameplate voltage. Crankcase heater, discharge line thermostat, internal temperature and current-sensitive motor overloads shall be included for maximum protection. Scroll type compressor shall provide inherently low vibration and noise by having no suction and discharge valves. External high and low pressure cutout devices shall be provided. Evaporator defrost control provided in the indoor blower coil shall prevent compressor slugging by temporarily interrupting compressor operation when low evaporator coil temperatures are encountered.

Condenser Coil

Coils shall be internally finned or smooth bore 3/8" copper tubes mechanically bonded to configured aluminum plate fin as standard. Factory pressure and leak tested to 420 psig air pressure. Metal grilles with PVC coating for coil protection is optional.

Condenser Fan And Motor(s)

Direct-drive, statically and dynamically balanced 26 or 28 inch propeller fan(s) with aluminum blades and electro-coated steel hubs shall be used in draw-through vertical discharge position. Either permanently lubricated totally enclosed or open construction motors shall be provided and shall have built in current and thermal overload protection. Motor(s) shall have be either ball or sleeve bearing type.

Mechanical Specifications

Condensing Units

Controls

Condensing units shall be completely factory wired with necessary controls and contactor pressure lugs or terminal block for power wiring. Unit shall provide an external location for mounting a fused disconnect device.

A choice of microprocessor or electro-mechanical controls shall be available. The 24-volt electro-mechanical control circuit shall include control transformer and contactor pressure lugs for power wiring. Units shall have single point power entry as standard.

The microprocessor controls shall provide for all 24-volt control functions. The resident control algorithms shall make all heating, cooling and/or ventilating decisions in response to electronic signals from sensors measuring indoor and outdoor temperatures. The control algorithm maintains accurate temperature control, minimizes drift from set point, and provides better building comfort. A centralized microprocessor shall provide anti-short cycle timing and time delay between compressors to provide a higher level of machine protection.

Time delay timers shall be provided to help prevent compressors in dual compressor units from simultaneous start-up. An anti-short cycle timer shall be available as an optional accessory.

Zone Sensor

This field installed control shall be provided to interface with the Micro equipped units and shall be available in either manual, automatic programmable with night setback, with system malfunction lights, or remote sensor options.

Thermostat

Two stage heating and cooling operation or one stage heating and cooling shall be available for field installation in either manual or automatic changeover. Automatic programmable electronic with night setback shall also be available.

Low Ambient Operation

Standard units shall start and operate to approximately 50°F when matched with air handlers and coils. Optional head pressure control accessory permits operation to 0°F.

FACTORY INSTALLED

ACCESSORIES

Black Epoxy Coated Condenser

Coil — The black epoxy coils have a thermoset vinyl coating that is bonded to the aluminum fin stock prior to the fin-stamping process. The pre-coated coils are an economical option for protection in mildly corrosive environments.

ACCESSORIES

Low Ambient Head Pressure Control

— Shall modulate the RPM of unit outdoor fan motor in response to outdoor ambient temperature and discharge line pressure. Accessory provides unit cooling operation to outdoor temperatures of 0F.

Vibration Isolation Packages

— Shall reduce transmission of noise and vibration to building structures, equipment and adjacent spaces. Packages shall be available in either neoprene-in-shear or spring-flex types.

Hot Gas Bypass Kit — Shall be available to provide capacity modulation.

Time Delay Relay — Shall prevent compressors in dual compressor unit from coming on line simultaneously. Timer shall be 24-volt, 60 cycle, with four minute timing period.

Anti-Short-Cycle Timer — Shall prevent rapid on-off compressor cycling in light load conditions by not allowing compressor to operate for 5-7 minutes upon shutdown. Shall consist of a solid state timing device, 24-volt, 60 cycle with either 5 or 7 minute fixed-off timing period.

Condenser Coil Guard — Metal grille with PVC coating shall be provided to alleviate coil damage.

Mechanical Specifications

Air Handlers

General

Air handler units shall be completely factory assembled including coil, condensate drain pan, fan motor(s), filters and controls in an insulated casing that can be applied in either vertical or horizontal configuration. Units shall be rated and tested in accordance with ARI standard 210/240, 340/360. Units shall be UL listed and labeled in accordance with UL 465/1995 for indoor blower coil units.

Casing

Unit casing shall be constructed of zinc coated, heavy gauge, galvanized steel. Exterior surfaces shall be cleaned, phosphatized and finished with a weather-resistant baked enamel finish. Casing shall be completely insulated with cleanable, foil faced, fire-retardant, permanent, odorless glass fiber material. All insulation edges shall be either captured or sealed. Knockouts shall be provided for unit electrical power and refrigerant piping connections. Captive screws shall be standard on all access panels.

Refrigeration System

The TWE060A, TWE090A, TWE120A units shall have a single refrigeration circuit and the TWE060B, TWE090B, TWE120B, TWE180B, TWE240B units shall have dual refrigeration circuits. Each refrigeration circuit is controlled by a factory-installed thermal expansion valve.

Evaporator Coil

Configured aluminum fin surface shall be mechanically bonded to 3/8" internally enhanced copper tubing and factory pressure and leak tested at 375 psig. Coil is arranged for draw-through airflow and shall provide a double sloped condensate drain pan constructed of PVC plastic. The drain pan shall be removable for cleaning. The condensate drain pan can be installed in any of four positions allowing for vertical or horizontal application and providing external connections on either side of the unit.

Evaporator Fan

Double inlet, double width, forward curved, centrifugal-type fan(s) with adjustable belt drive shall be standard. Thermal overload protection shall be standard on motor. Fan and motor bearings shall be permanently lubricated. Oversized motors shall be available as an option for high static application. All indoor fan motors meet the U.S. Energy Policy Act of 1992 (EPACT).

Controls

Magnetic evaporator fan contactor, low voltage terminal strip, check valve(s), and single point power entry shall be included. All necessary controls shall be factory-installed and wired. Evaporator defrost control shall be included to prevent compressor slugging by temporarily interrupting compressor operation when low evaporator coil temperatures are encountered.

Filters

One inch, throw-away filters shall be standard on TWE060A, TWE060B, TWE090A, TWE090B, TWE120A AND TWE120B model air handlers. Filters shall be accessible from the side coil access panel. Filter rack can be field converted to two inch capability. Two inch, throw-away filters shall be standard on TWE180B and TWE240B models.

ACCESSORIES

Hydronic Heat Coils — One row steam and two row hot water coils shall be available for mounting on the discharge outlet of the air handler. Coils shall be shipped completely factory assembled within a heavy gauge sheet metal casing, finished with enamel to match the blower coil unit. Coils shall be applied in either vertical or horizontal airflow configurations.

Electric Heaters — UL and CSA approved electric heat modules shall be available for installation directly on fan discharge. Electric Heaters shall

be available in a wide range of capacities with one or two stage control, single-point electric power connection and terminal strip connections. Electric heater elements shall be constructed of heavy-duty nickel chromium elements internally wye connected on 480/600 volt, three phase and delta connected on 208/240 volt, three phase. Each 208/240 volt heater shall have pilot duty with secondary backup fuse links for automatic reset of high limit controls. Each 480/600 volt heater shall have automatic line break high limit controls.

Evaporator Coils — Shall be completely factory assembled including the expansion valves and drain pans. The TXE120B coil shall be dual refrigerant circuits. Unit casing shall be constructed of zinc coated, heavy gauge, galvanized steel. Exterior surfaces shall be cleaned, phosphatized and finished with an enamel finish. Casing shall be completely insulated with foil faced, fire-retardant, permanent, odorless glass fiber material. The coils shall be convertible to either vertical and/or horizontal airflow configuration. Aluminum fin surface shall be mechanically bonded to 3/8" OD copper tubing. Coils shall be factory pressure and leak tested.

Discharge Plenums and Grilles — Accessory discharge plenums shall be available for vertical, free discharge applications. Plenums shall be constructed of heavy-gauge, zinc coated galvanized steel finished with baked enamel to match the air handler unit. Grilles shall be satin finished aluminum and have four-way adjustable louvers.

Return Air Grilles — Accessory return air grille shall be provided for vertical front, free return applications. Grilles shall be installed in place of the front lower side panel. Grille shall be satin finished aluminum with non-adjustable louvers.

Mechanical Specifications

Air Handlers

Mounting Subbase — Available for vertical floor mount configurations. Subbase shall be constructed of heavy gauge, zinc coated galvanized steel with baked enamel finish to match air handler unit. Subbase is required in the vertical air flow application for condensate drain trapping and when isolators are required.

Vibration Isolators — Shall reduce transmission of noise and vibration to building structures, equipment and adjacent spaces. Packages shall be available in either neoprene-in shear or spring-flex types in floor or suspended mountings.

Oversized Motors — Field installed oversized motors shall be available for high static pressure applications.

Control Options

Standard Indoor Thermostats — Two stage heating and cooling operation or one stage heating and cooling thermostats shall be available in either manual or automatic changeover.

Programmable Electronic Night Setback Thermostat — Shall provide heating setback and cooling setup with 7-day programming capability.



*See Operational Manual OM-340 for exceptions.

American Standard Company has a policy of continuous product and product data improvement and reserves the right to change design and specifications without notice.

Technical Literature Printed in USA

The American Standard Company
2701 Wilma Rudolph Blvd.
Clarksville, TN 37040

www.americanstandard.com