

SPLICE PLATE & BOLT TABLE									
Mark	Qty		Int	Type	Dia	Length	Width	Thick	Length
	Top	Bot							
SP-1	4	4	0	A325	0.750	2.00	6"	3/8"	1'-4"
SP-2	4	0	0	A325	0.750	2.00	6"	3/8"	9 1/4"

MEMBER TABLE									
Mark	Weight	Length	Web Depth		Web Plate		Outside Flange		Inside Flange
			Start/End	Thick	Thick	Length	W x Thk x Length	W x Thk x Length	
RF1-100	135	9'-9 11/16"	8.0/8.0	0.135	4'-0"	5 x 1/4" x 9'-9 1/8"	5 x 1/4" x 8'-11 5/16"		
RF1-101	95	5'-11 3/16"	8.0/7.5	0.135	6'-0 3/16"	5 x 1/4" x 5'-10 3/8"	5 x 1/4" x 5'-10 3/8"		

∇ FLANGE BRACES: Both Sides(U.N.)
 FBxxB(1): xx=length(in)
 B - FB2X1/8

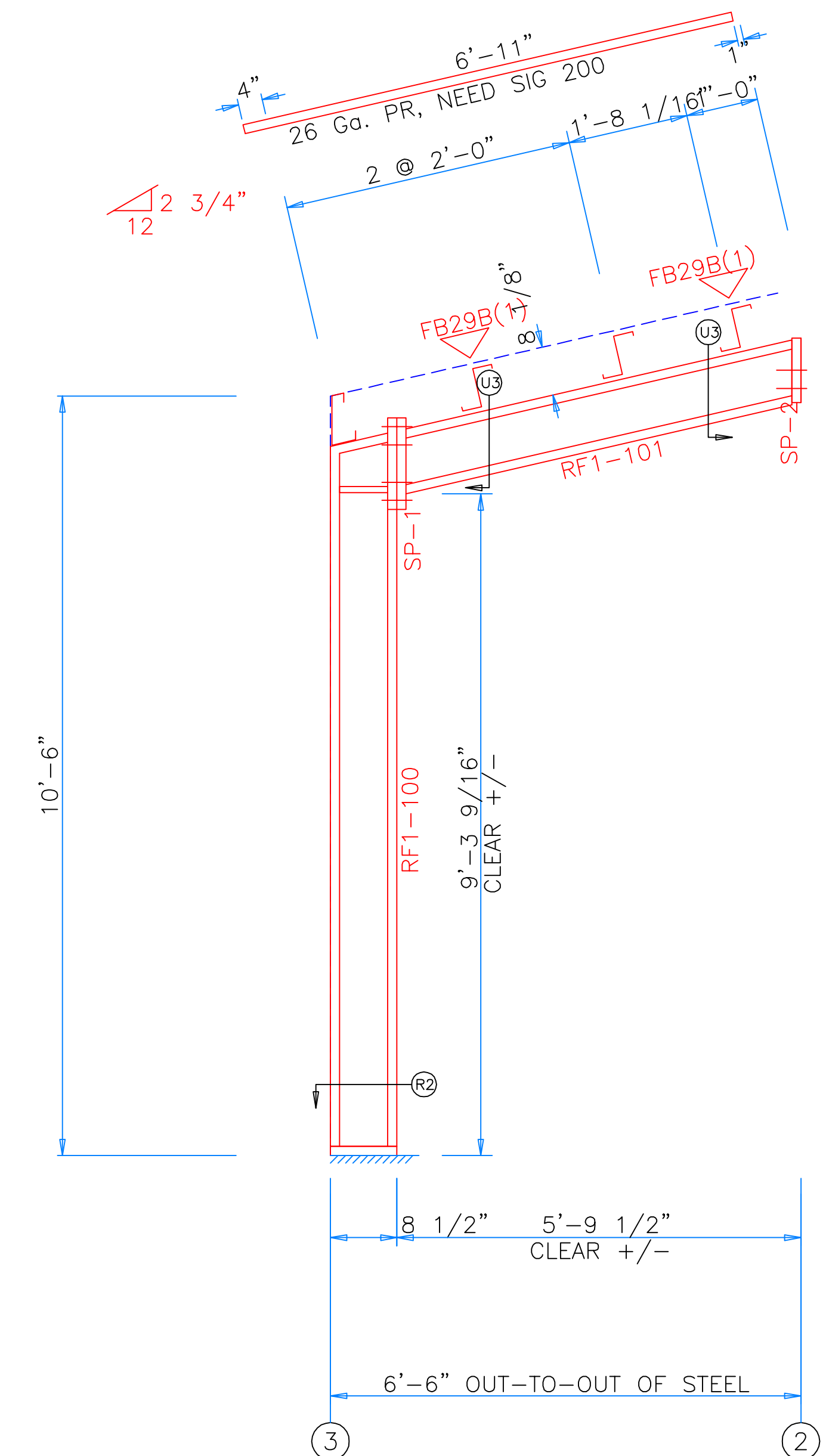

RIGID FRAME ELEVATION: FRAME LINE B C

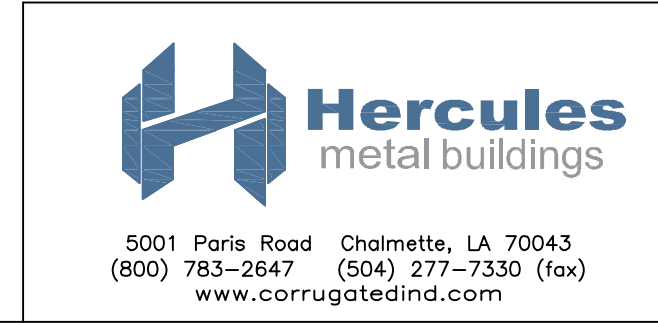

DESCRIPTION: RIGID FRAME ELEVATION							
CUSTOMER: DLR				PROJECT: PRJ			
LOCATION: PRJ Address 2							
DRN. BY	CK'D BY	DATE	SCALE	REV.	QUOTATION NO.	SHEET NO.	
DET	DES	6/23/20	N.T.S.	00	124-2	OF	