

FILE NOTES

1. PRIOR TO PILE DRIVING (WHERE PILES ARE REQUIRED) IT IS RECOMMENDED THAT OWNER VERIFY PILE SIZE AND CAPACITY BY CONTRACTING THE SERVICES OF A SOILS ENGINEERING COMPANY, OR AS AN ALTERNATIVE, VERIFY PILE CAPACITY WITH A PILE LOAD TEST. IF NO SOILS ANALYSIS FOR THE PROPERTY HAS BEEN PROVIDED TO ENGINEER, CONTRACTOR MUST ADVISE OWNER THAT PILE LOAD CAPACITIES USED ARE BASED ON LOCAL CODES AND HISTORICAL INFORMATION WHERE AVAILABLE, AND THAT THE SOILS DATA FOR THE SPECIFIC PROJECT AREA MAY NOT BE COMMENSURATE WITH THESE DATA.
2. PILES ARE TO BE HELICAL 10" SCREEN PILES.
3. DESIGN LOAD = 4 TONS PER PILE. CONTRACTOR SHALL TEST ONE PILE USING ANY APPROVED ASTM METHOD.
4. NO FIELD SUPERVISION OR INSPECTION PROVIDED UNDER THIS SEAL UNLESS OTHERWISE NOTED.
5. PILE LAYOUT MAY BE MODIFIED DUE TO ACTUAL DRIVING CONDITIONS. ENGINEER TO BE NOTIFIED ON ANY MODIFICATION.
6. THIS PILE SUPPORTED FOUNDATION IS DESIGNED TO MEET THE GENERAL SOIL CONDITIONS OF THE AREA OF WORK. THE CONTRACTOR OR OWNER IS ADVISED THAT A SOIL ANALYSIS SHOULD BE MADE TO CONFIRM THE DESIGN.

GENERAL FOUNDATION NOTES

1. ALL DIMENSIONS ARE EDGE OF CONCRETE (EOC) TO EDGE OF CONCRETE (EOC) UNLESS NOTED OTHERWISE.
2. CONCRETE MIX SHALL HAVE A MINIMUM COMPRESSIVE STRENGTH OF 4000 PSI AT 28 DAYS. CONCRETE MIX SHALL BE IN ACCORDANCE WITH ACI-318.
3. ALL CONVENTIONAL REINFORCING STEEL SHALL MEET ASTM-A615 (GRADE 60).
4. ONE LAYER OF POLYETHYLENE VAPOR BARRIER SHALL BE PLACED UNDER ALL CONCRETE. VAPOR RETARDER TO BE MINIMUM 10 MIL THICKNESS; ASTM E 1145 CLASS A, PERMEANCE LESS THAN 0.01 PERMS. EQUAL TO STEGO INDUSTRIES STEGO WRAP, ECOSHIELD-E 15 MIL BY EPFO, OR IRONBAR 15 BY PLATIRON FILMS. PROVIDE APPROPRIATE ACCESSORIES FOR A COMPLETE SYSTEM.
5. ALL REINFORCING STEEL AND MESH SHALL BE SECURELY SUPPORTED TO PREVENT BOTH VERTICAL AND HORIZONTAL MOVEMENT DURING CONCRETE PLACEMENT.
6. THE CONTRACTOR SHALL VERIFY ALL DROPS, OFFSETS, BRICK LEDGES, DIMENSIONS AND CONFIGURATIONS.
7. GRADE BEAM DIMENSIONS MAY VARY BY -5%, +20%.
8. FILL, AS A MINIMUM QUALITY, SHALL BE 40% CLAY AND 60% SANDY MIXTURE, PLACED IN 6" LIFTS AND COMPACTED TO A MINIMUM OF 95% STANDARD PROCTOR. FOOTINGS ARE DESIGNED TO USE SOIL WITH A BEARING PRESSURE OF 2000 LBS. PER SQUARE FOOT OR MORE. IT IS RECOMMENDED THAT THE OWNER VERIFY ALLOWABLE SOIL BEARING PRESSURE CAPACITY BY CONTRACTING THE SERVICES OF A SOILS ENGINEERING COMPANY.
9. ALL SOIL BELOW SLAB SHALL RECEIVE TERMITES TREATMENT.
10. PROVIDE POSITIVE DRAINAGE AWAY FROM FOUNDATION AT ALL TIMES.

GENERAL NOTES

1. ALL LUMBER SHALL BE PRESSURE TREATED WITH A RETENTION OF 4 PER C.F.
2. ALL FASTENERS SHALL BE HOT DIPPED GALVANIZED (HDG) PER ASTM A153.
3. ALL CONNECTORS SHALL BE HDG PER ASTM A653, CLASS 6105 SHEET WITH 1.95 OZ/SF ZINC COATING.

DESIGN CRITERIA

THE CONSTRUCTION FOR SAID RESIDENCE, WHERE BASIC WIND SPEED IS 130 MILES PER HOUR, WIND EXPOSURE ZONE C, IS DESIGNED IN ACCORDANCE WITH: AMERICAN FOREST AND PAPER ASSOCIATION (AF&PA) WOOD FRAME CONSTRUCTION MANUAL FOR ONE AND TWO FAMILY DWELLINGS (WFCM) 2001 EDITION AS WELL AS THE INTERNATIONAL RESIDENTIAL CODE (IRC) 2021 EDITION

DAMMON ENGINEERING, INC.
LOUISIANA & MISSISSIPPI
www.dammonengineering.com
info@dammonengineering.com
PH: 985.649.8832

Chief Engineer: Brian Misch, PE
554 Old Spanish Trail
Shreveport, LA 70458

REVISIONS	DATE	DESCRIPTION

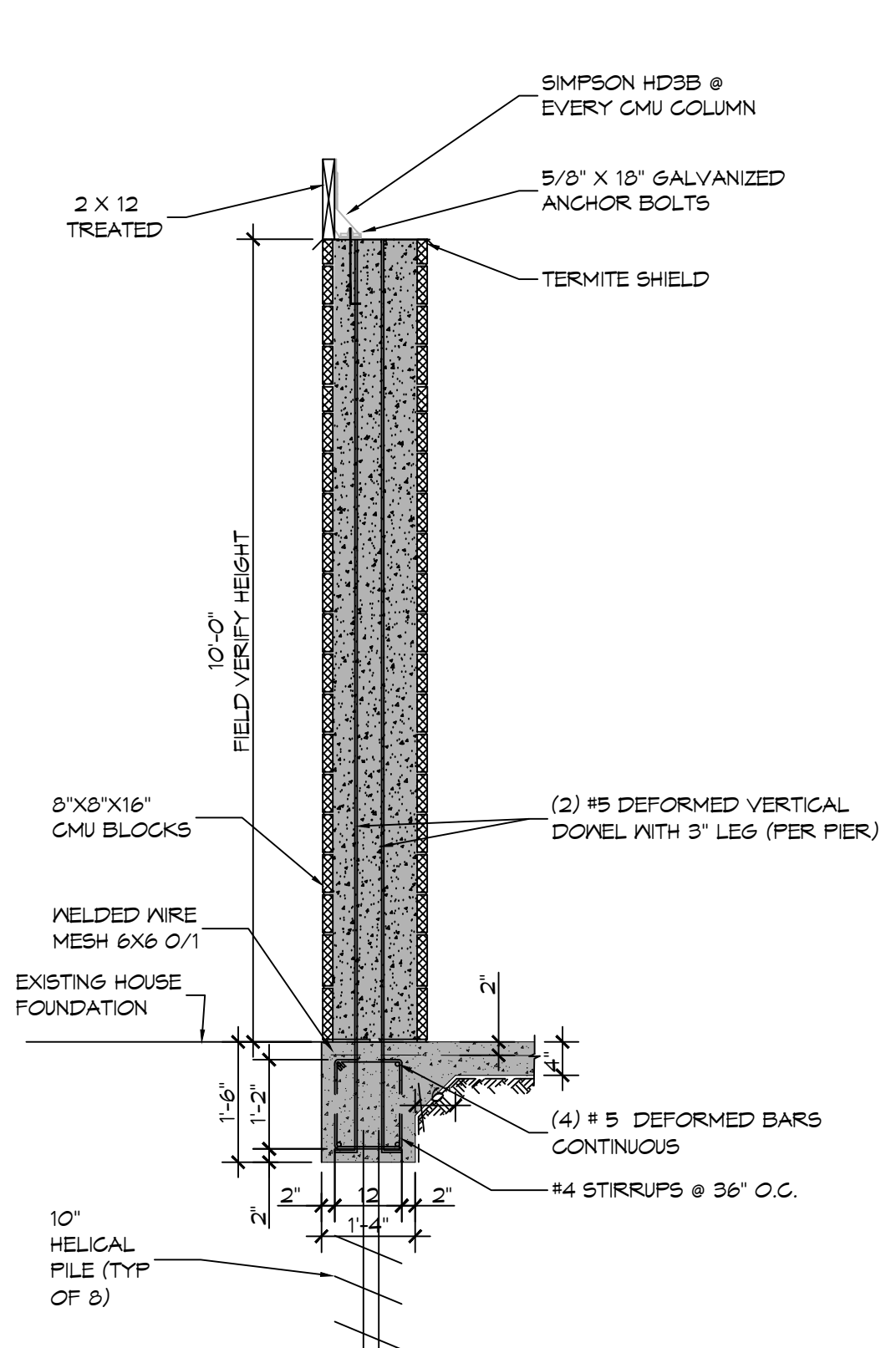

A SECTION
SCALE: 1/2" = 1'-0"
DECK FOUNDATION

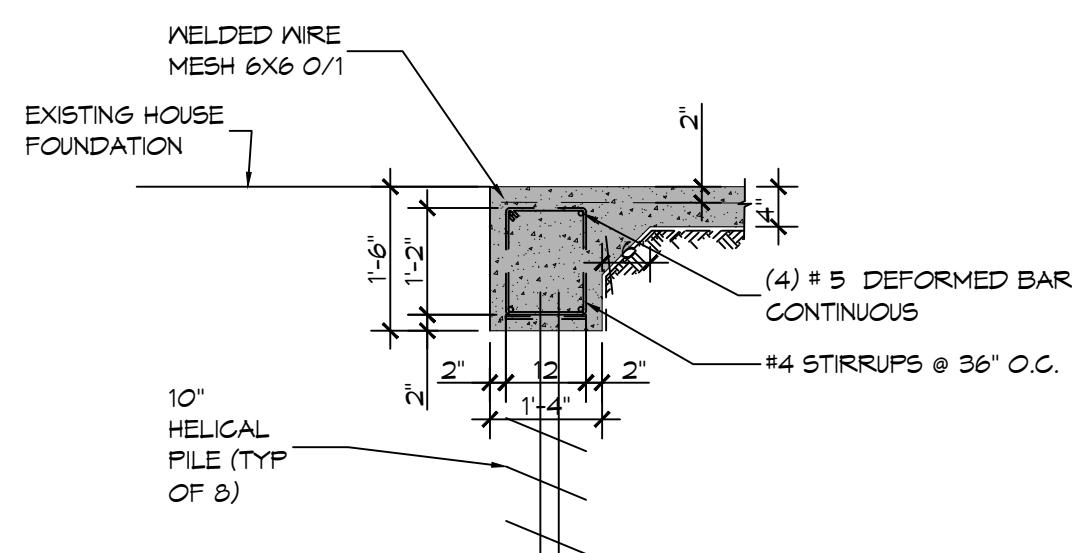

B SECTION
SCALE: 1/2" = 1'-0"
FOUNDATION

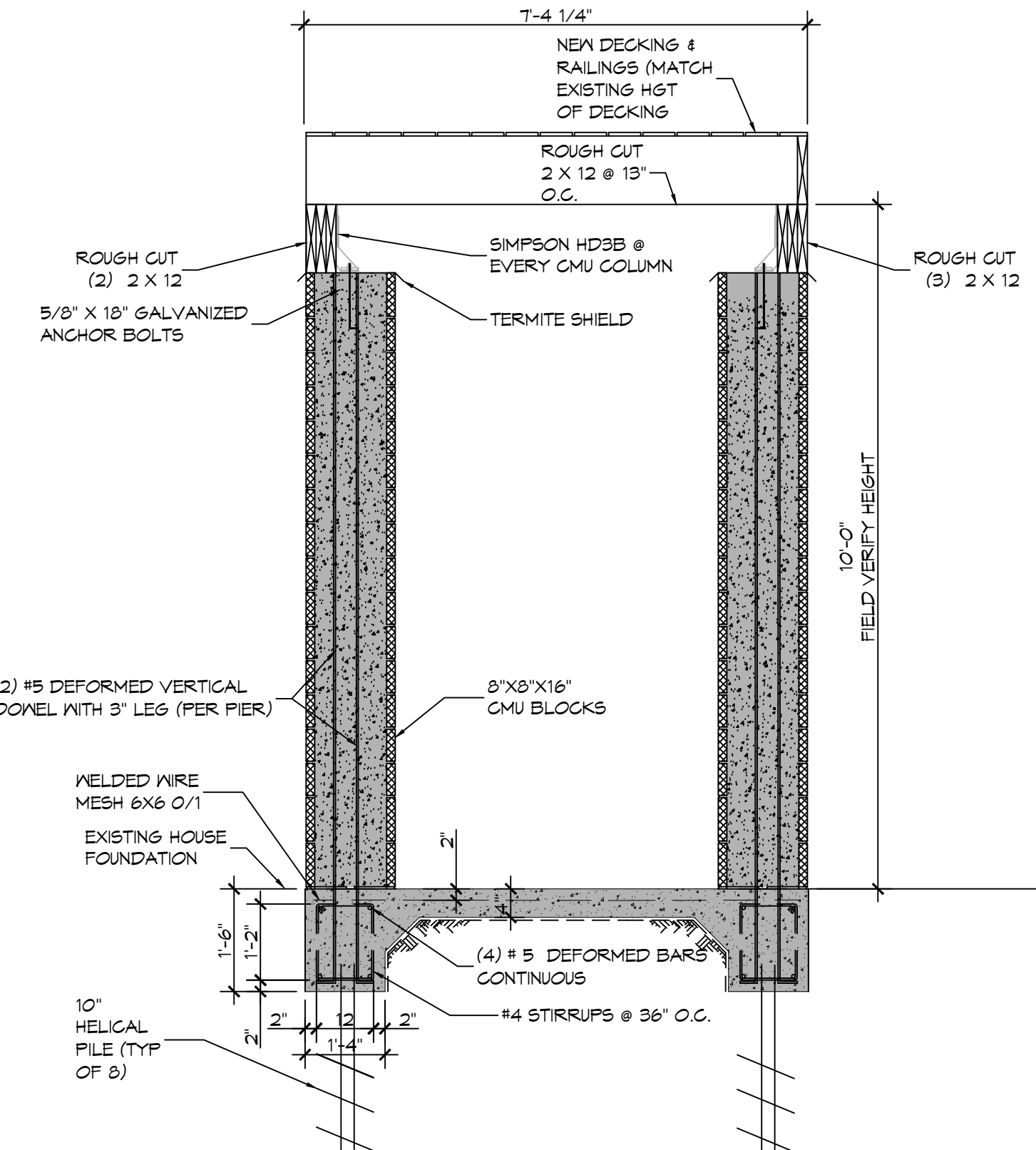

C SECTION
SCALE: 1/2" = 1'-0"
HOT TUB SECTION

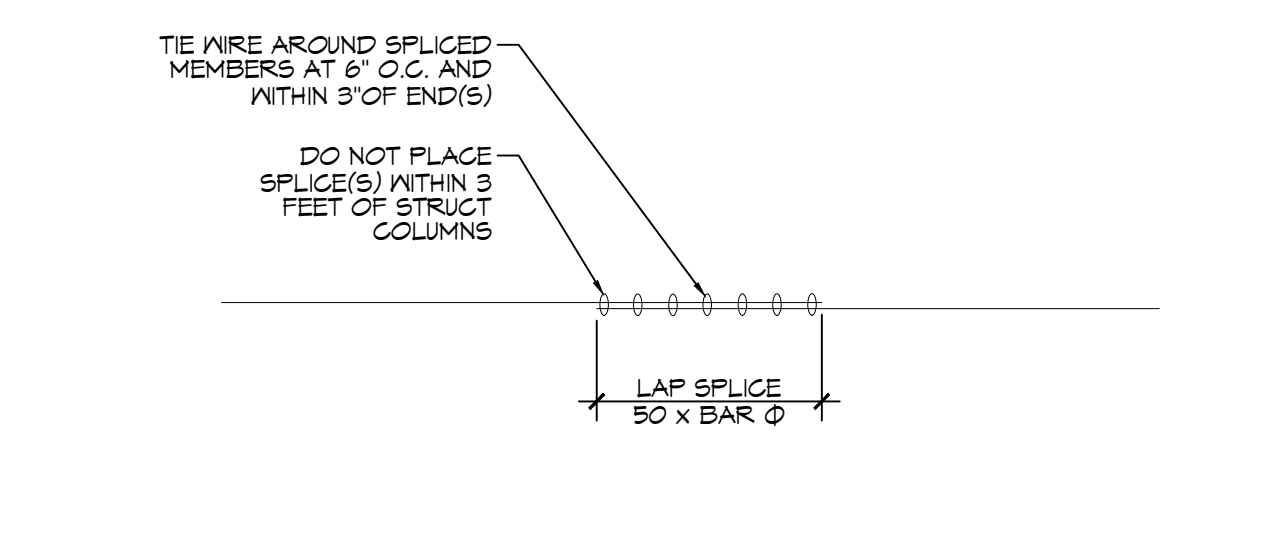

D SECTION
SCALE: 1/2" = 1'-0"
LAP SPLICE

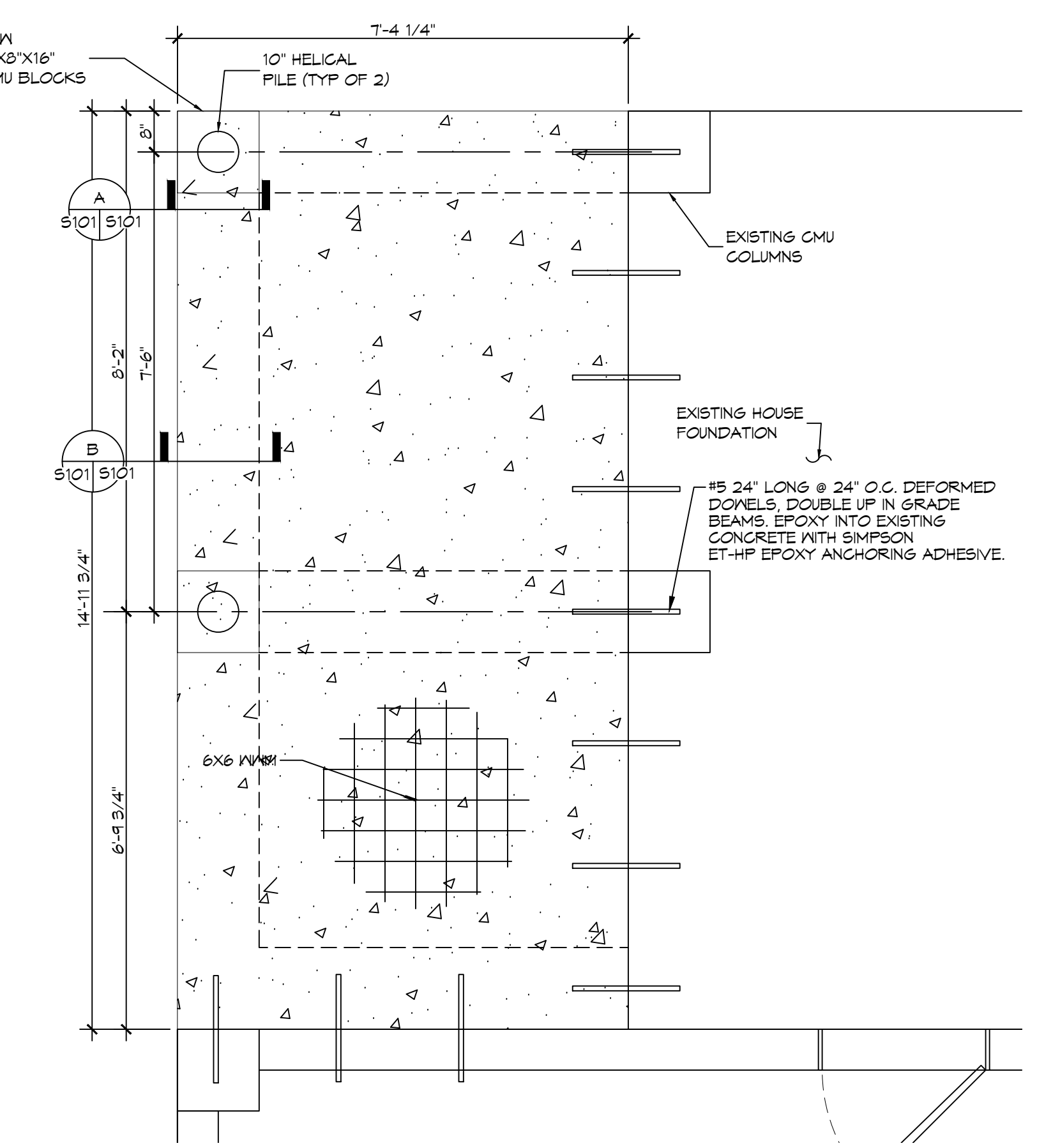

6 DECK FOUNDATION PLAN
SCALE: 1/2" = 1'-0"

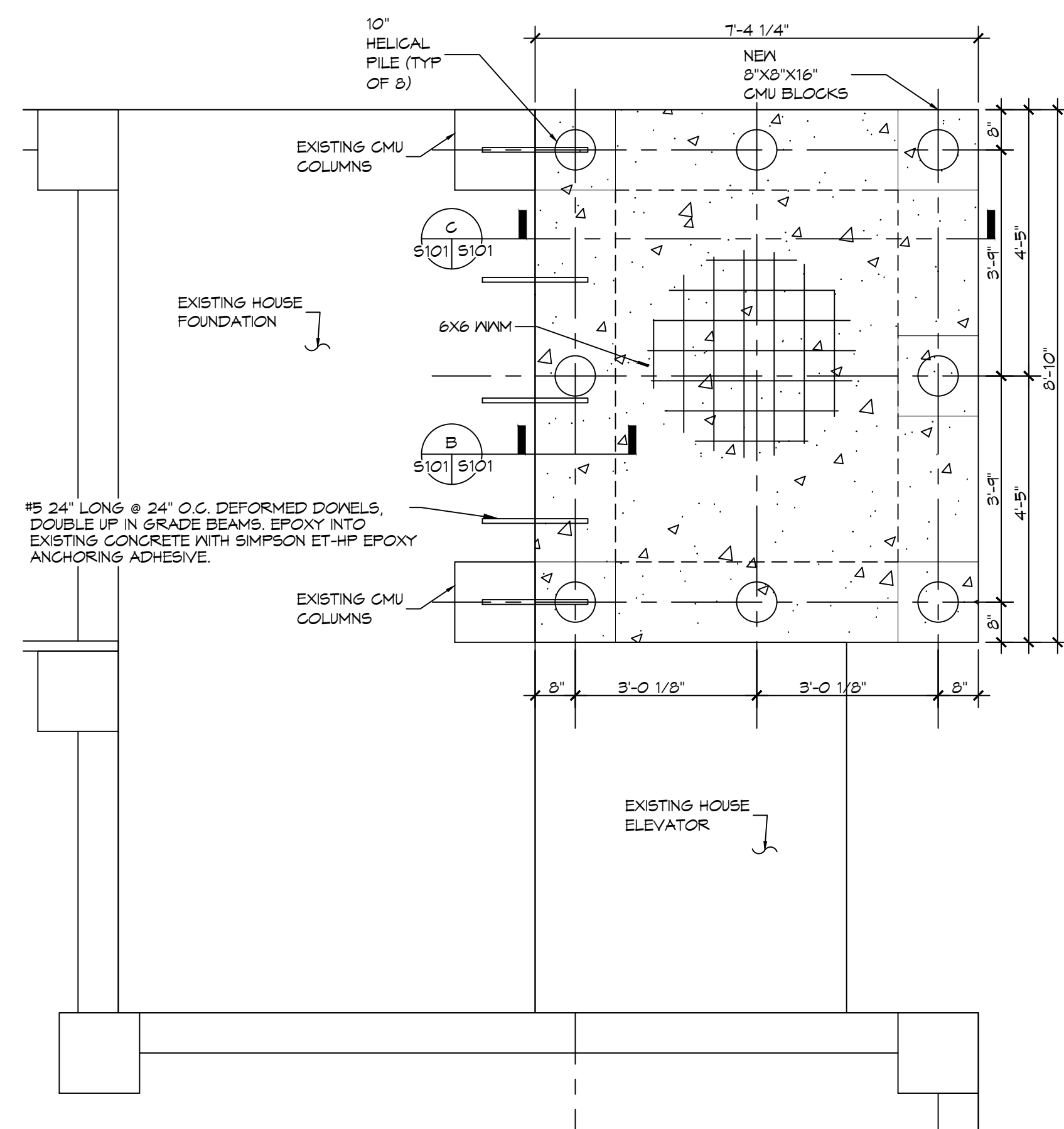

7 HOT TUB FOUNDATION PLAN
SCALE: 1/2" = 1'-0"

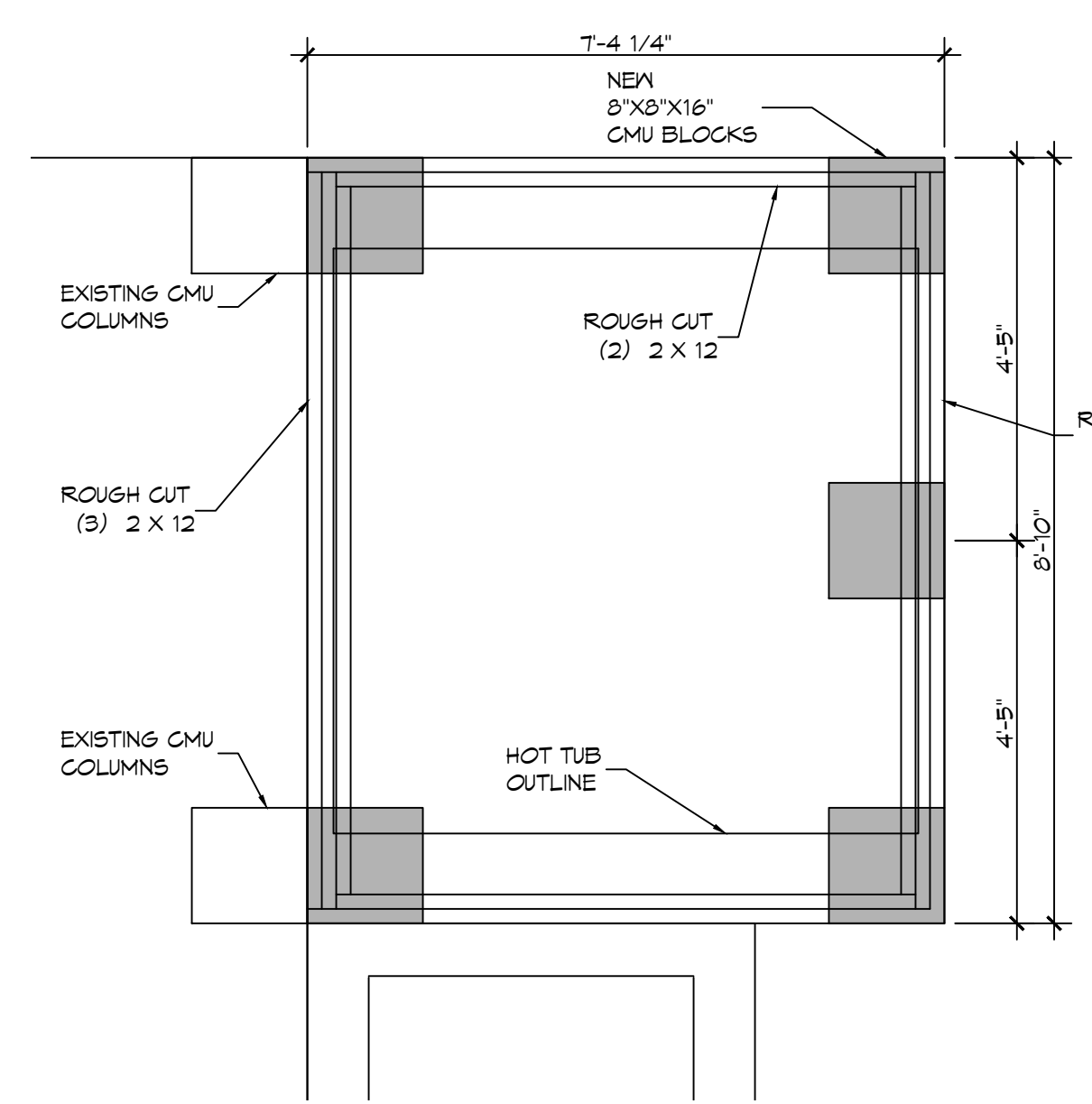

8 SILL FRAMING PLAN
SCALE: 1/2" = 1'-0"

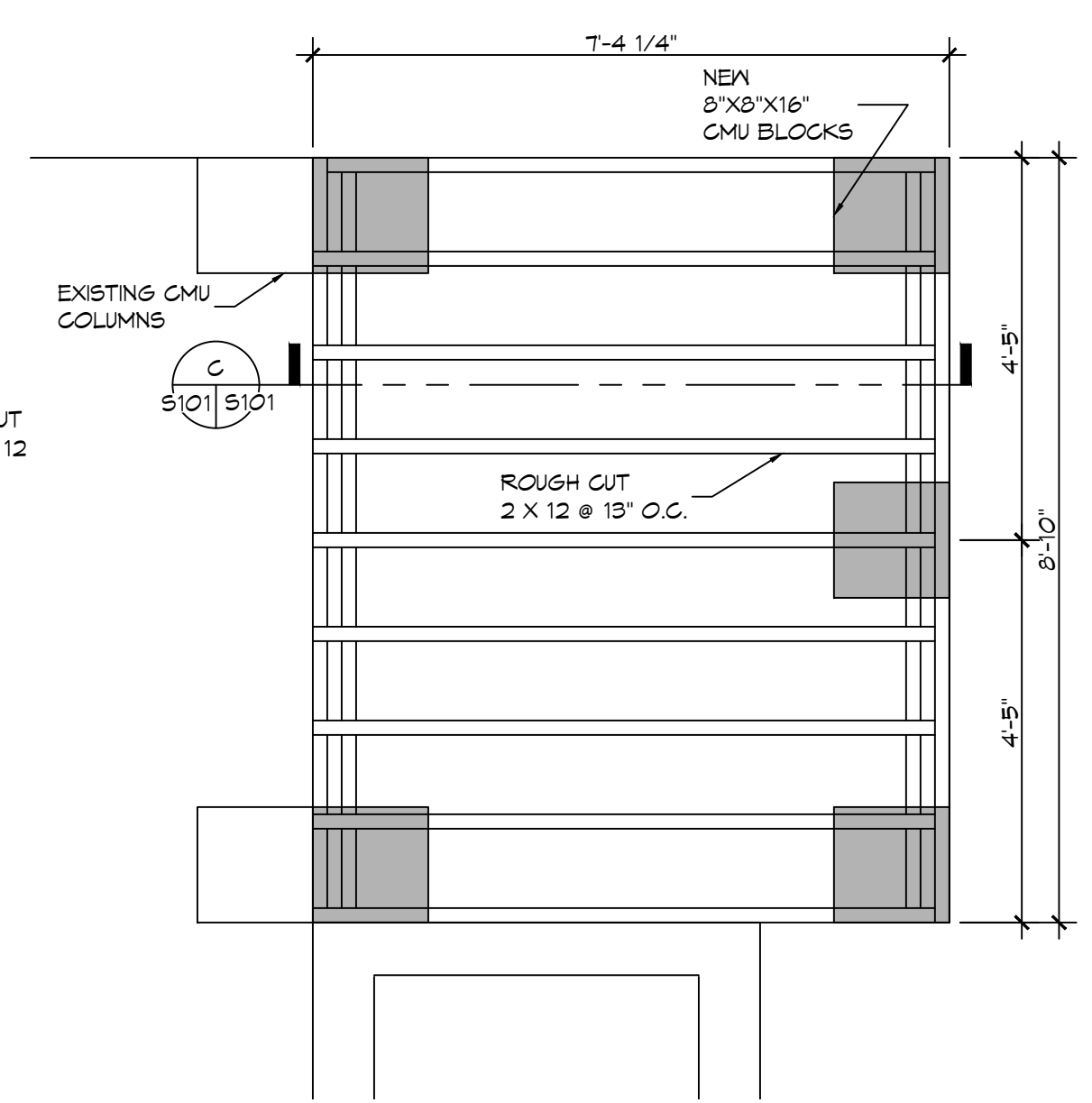

9 JOIST PLAN
SCALE: 1/2" = 1'-0"

STRUCTURAL DWGS
BRIAN FONG
2020 MAX JUDE LANE
MONROEVILLE, LA 70471
JOB No: 2023 DATE: 10-04-2023
DRAWN BY: KCD CHECKED BY: BAM

SHEET TITLE:
HOT TUB & DECK
FRAMING PLAN
DRAWING NUMBER:
S102
SHEET No: 2 of 2