

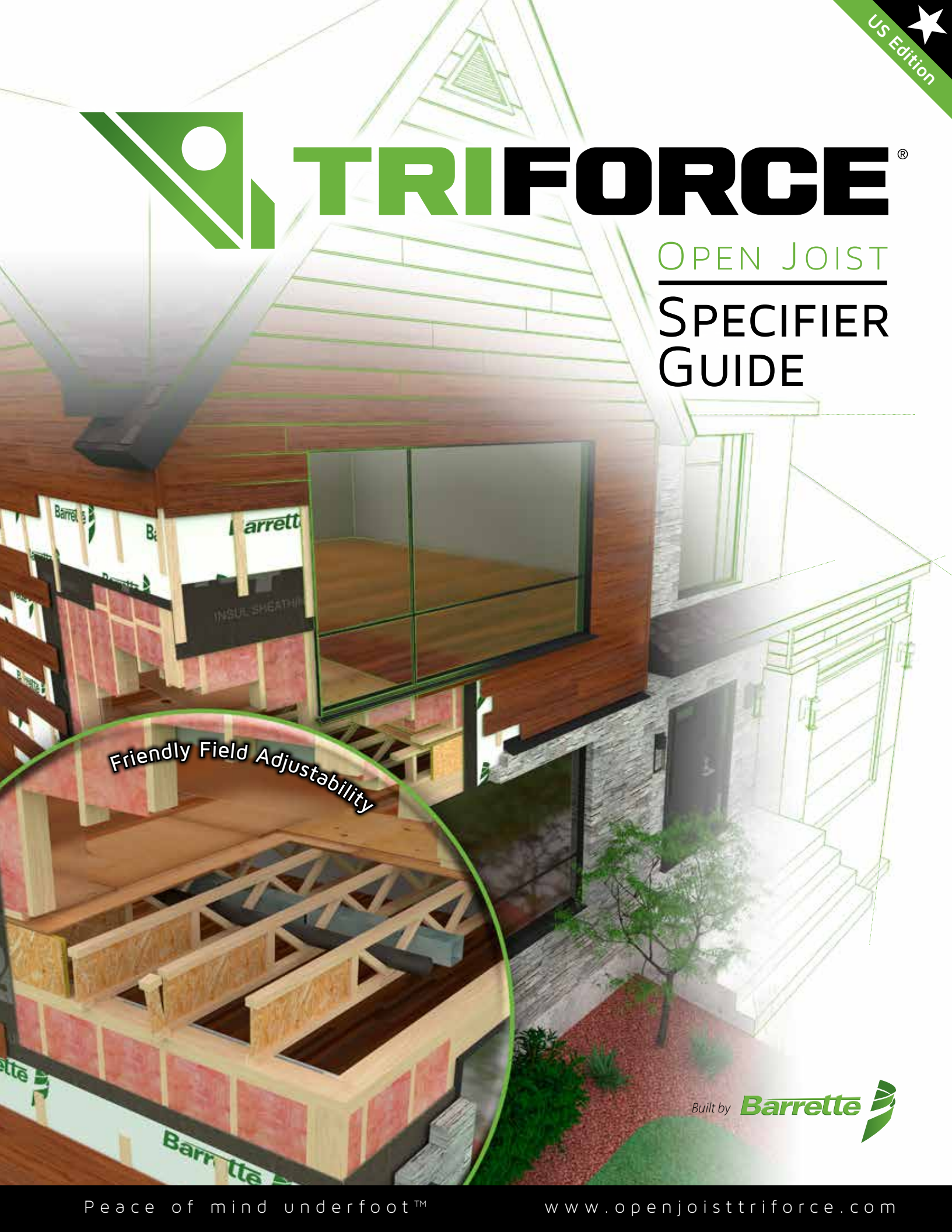

TRIFORCE[®]

OPEN JOIST SPECIFIER GUIDE



Friendly Field Adjustability

Built by **Barrette** 

This brochure is intended to provide general information for designer and end-user. For further information or assistance with our open joist **TRIFORCE**[®], please contact your Barrette Structural representative

In keeping with its on-going product development engagement, Barrette Structural periodically revises its literature. Please visit our website www.openjoisttriforce.com to verify that this is an updated version.

www.openjoisttriforce.com
info@ojtriforce.com



Open Joist | Specifier Guide





An unusual building

The open joist **TRIFORCE**[®] is manufactured in a new facility built with glued laminated lumber posts and beams, designed in function of the principles of sustainable development. Our plant with an area of 180 000 pi², is the largest industrial building using glued laminated lumber in eastern Canada.

Here are the principles of sustainable development that we have applied during this project:

- Support for the lumber industry and its workers.
- Third processing of a natural resource.
- Training of specialized workers, wood joist assemblers, whose expertise is already being used to advantage on other projects.
- Lumber derived from a certified forest that respects the principles of sustainable forestry.
- Use of a local and renewable resource.
- Energy savings.
- Reduction in greenhouse gases (GHG).
- Solar walls.
- Insulating with aesthetics in mind.
- Protecting the water table.



Table of Contents



2	Evaluation Reports
3	Features and Benefits
3	Adjustment
4	Identification
5	Design Values
6	Stocking Lengths
7	L/480 Span Chart
8	L/360 Span Chart
9	L/480 Load Chart
10	L/360 Load Chart
11	Strongback Recommendation Chart
12	Installation
13	Storage & Handling
14	Typical Details
15	Rim Board Connection
16	Interior Bearing Wall Blocking
17	Parallel Non-Load Bearing Wall Support
18	Perpendicular Blocking
19	Cantilevers
20	Steel Beam Connections with Hangers
21	Steel Beam Connections without Hangers
22	Multiple Joist Connectors (MJC) For Concentrated Side Load
23	Reinforcement for Concentrated Side Load
24	Reinforcement for Concentrated Top Load
25	Allowable OSB Panel End Hole Penetrations
25	Mechanical Clearances
26	Strongbacks
27	TRIFORCE® Floor Performance
28	Fire Performance
29	1-Hour Fire Resistance Rated Floor Assembly
31	Sound Performance
32	QuickTools Software
33	Single Framing Connectors
35	Double Framing Connectors
37	Warranty

Evaluation Reports



 **Canada**

CCMC-13474-R

 **United States**
 MEA 300-00-E
 #434B
 FL#5828

ESR-2999
 City of New-York
 City of Houston
 State of Florida



Most Widely Accepted and Trusted

ICC-ES Evaluation Report

ESR-2999

Reissued February 3, 2011

This report is subject to renewal in two years.

www.iccses.org | (800) 423-6587 | (562) 699-0543

A Subsidiary of the International Code Council®

DIVISION: 06 00 00—WOOD, PLASTICS AND COMPOSITES
Section: 06 17 03—Shop-Fabricated Wood Trusses

REPORT HOLDER:
 TRUSS-FORMERS, OPEN JOIST 2000 INC.
 581 ST-AUBIN
 TROIS-RIVERS, QUÉBEC G9V 0A8
 CANADA
 (819) 374-6061
www.ouj.com

EVALUATION SUBJECT:
 OJ SERIES PREFABRICATED OPEN WEB JOISTS

1.0 EVALUATION SCORE
 Compliance with the following codes:
 • 2009 International Building Code® (IBC)
 • 2009 International Residential Code® (IRC)
 Properly installed:
 Structural

1.1 UNES
 The OJ Series prefabricated open web joist joists are used as uniformly spaced floor joists and roof joists in both open and finished applications.

1.2 DESCRIPTION

1.2.1 General:
 The OJ Series prefabricated open web joist joists have solid-sawn lumber flanges connected by solid-sawn lumber vertical and diagonal web members forming diagonal webbed truss along the length, width of joist and which has a continuous oriented strand board (OSB) web to permit trimming to length in the field. The top and bottom flanges are parallel, creating a constant depth joist. The vertical and diagonal to flange connection is a proprietary glued finger joint and the OJ web and section connection is a proprietary glued tongue-and-groove joint to the flanges and to a vertical web transition post. Joint depths vary from 3.5 inches to 10 inches (91.5 mm to 254 mm). The joist has a top and bottom, with the bottom flange marked for proper installation during post placement. A vertical web member is always placed at the joint and opposite the OSB web and, see Table 1 and Figure 1 for descriptive information.

1.2.2 Material:
 1.2.2.1 **Flanges:** The OJ Series flange material is solid-sawn, species-grade (SPG) finger-jointed lumber meeting the grade requirements listed in the approved quality control manual.

1.2.2.2 **Diagonal Web:** The OJ Series diagonal web material is SPG proprietary grade solid-sawn lumber meeting the size and grade requirements listed in the approved quality control manual.

1.2.2.3 **Vertical Web:** The OJ Series web and joint end web material is SPG proprietary grade solid-sawn lumber meeting the size and grade requirements listed in the approved quality control manual.

1.2.2.4 **OSB Web:** The OJ Series OSB web material is minimum 7/8 inch thick complying with DOC Voluntary Product Standard PS2, Exposure 1 and requirements listed in the approved quality control manual. The OSB web is continuous from the web joint to the ends of the flanges. The OSB is oriented with face grain parallel to the joist flanges.

1.2.2.5 **Adhesive:** The adhesive used in the OJ Series joint transition complies with ASTM D 2059, Section 5.3.3 of ASTM D 2059-08a and requirements listed in the approved quality control manual.

1.3 DESIGN AND INSTALLATION

1.3.1 General:
 The design and installation of the OJ Series prefabricated open web joist joists described in this report shall comply with Sections 4.2 through 4.12 and the manufacturer's published installation instructions. Additionally, design of the OJ Series joist is governed by the applicable code and corresponding sections of the ANGLISMA National Design Specification for Wood Construction (NDS).

1.3.2 Allowable Capacity:
 Table 2 specifies allowable moment, shear, and bending stiffness (EI) and shear deflection coefficients (G). Reference design values given in Table 2 must be adjusted by applicable factors in accordance with Sections 4.2.1 through 4.2.5.

1.3.3 Load Duration Factor, C_d: Adjustments for duration of load apply to the reference design values in accordance with Section 7.3.2 of the NDS.

1.3.4 Wet Service Factor, C_w: OJ Series joists must be installed in dry, covered conditions where the in-service moisture content of the joist is less than 18 percent. The wet service factor, C_w, for OJ Series joists under these conditions is 1.0.

1.3.5 Temperature Factor, C_t: Where OJ Series joist will be exposed to sustained in-service temperatures greater than 102°F (38°C), the reference design values must be adjusted by the temperature factor, C_t, in accordance with Section 7.3.4 of the NDS.

ICC-ES Evaluation Reports are not to be construed as representing verification or other services not specifically outlined and approved in the contract. The information herein is for general informational purposes only. The information herein is not intended to constitute an offer of insurance or other financial product. The information herein is not intended to constitute an offer of insurance or other financial product. The information herein is not intended to constitute an offer of insurance or other financial product. The information herein is not intended to constitute an offer of insurance or other financial product.

 Page 1 of 4



Evaluation Report

CCMC 13474-R

Open Joist TRIFORCE™ Series

1. Opinion

It is the opinion of the Canadian Construction Materials Centre (CCMC) that "Open Joist TRIFORCE™ Series" when used as joists in floor and roof applications in accordance with the conditions and limitations stated in Section 3 of this Report, complies with the National Building Code 2005:

- Clause 1.2.1.1.1.(1)(a), Division A, using the following acceptable solutions from Division B:
 - Sentence 4.3.1.1.(1) Design Basis for Wood (CAN/CSA-O86-0), reliability-based joist strength qualification and stiffness qualification)
- Clause 1.2.1.1.1.(1)(b), Division A, as an alternative solution that achieves at least the minimum level of performance required by Division B in the areas defined by the objectives and functional statements attributed to the following applicable acceptable solutions:
 - Sentence 9.23.4.2.(2) Spans for Joists, Rafter and Beams (i.e. alternative floor joist solution).

This opinion is based on CCMC's evaluation of the technical evidence in Section 4.1 provided by the Report Holder.

2. Description

The "Open Joist TRIFORCE™ Series" are parallel chord trusses with diagonal wood webs. The top and bottom chords are available in either 2x3 or 2x4 finger-jointed proprietary grade lumber (see Figure 2.1). The diagonal web members are short 2x2 pieces of lumber and finger-jointed into the top and bottom chords. The joists have a trimmable end-section at one end and an end post at the other end. The trimmable end section is an 80-ram long OSB web section, which is similar to an I-joist, and may be trimmed in the field a maximum of 610 mm (24 in.) (i.e. 194 mm (7.58 in.) remaining). The chord sizes are outlined in Table 2.1.

The chord fingerjoints and the web-to-chord connections are all adhered with a phenol-resorcinol adhesive meeting CSA O112.7, "Phenol, Resorcinol and Phenol-Resorcinol Resin Adhesives," (CCMC 12917-L). The OSB web complies with CAN/CSA-O325.0-02, "Construction Sheathing," and PS-2.

MASTERFORMAT: 06 17 01 01
 Issued: 2010-02-09
 File-evaluation date: 2013-02-09

Features and Benefits

FEATURES	BENEFITS
SOLID SAWN KILN-DRIED CHORDS	<ul style="list-style-type: none"> • Wide nailing surface 2.5" and 3.5" • Glued finger joints eliminate potential squeaking • Dimensional stability • Ease of installation
SOLID SAWN KILN-DRIED WEBS	<ul style="list-style-type: none"> • 2" X 2" webs • Most effective wood usage • Environmentally-friendly
WEB STOCK OSB END DETAIL	<ul style="list-style-type: none"> • 24" trimmable end • Trimmable one end only • Manufactured in 2-foot increments
GLUED FINGER JOINTS TRIANGULATION	<ul style="list-style-type: none"> • Long-term performance • Accuracy • No plate corrosion • No potential mechanical, electrical and plumbing damage due to metal connectors • Eliminates potential squeaking
TRIANGULATED CONFIGURATION	<ul style="list-style-type: none"> • Proven • Light handling • No on-site thinking for holes to allow mechanical, electrical and plumbing installation • Increased floor performance
QUALITY GUARANTEED	<ul style="list-style-type: none"> • Independent third-party inspection • Individually tested to exceed load capacity • Unrivaled floor performance

Adjustment

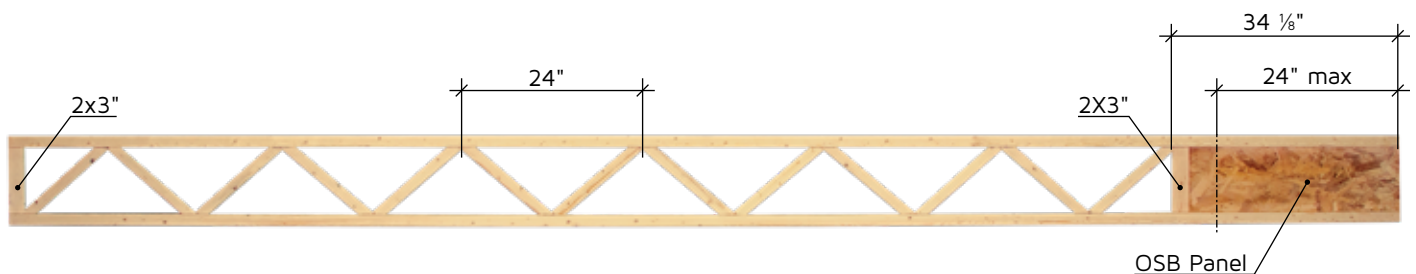

The Barrette Structural open concept floor system

The strength of triangulation, accuracy of finger-jointed assembly, maximization of dimensional lumber and environmentally-friendly field adjustability, makes open joist **TRIFORCE**® product the only trimmable all-wood, open-webbed, finger-jointed, floor joists without metal plate connectors.

Reengineering wood components for your needs

For more than 25 years, OPEN JOIST 2000® products have demonstrated their strength and durability throughout North America and Europe. The open joist **TRIFORCE**® product is the logical continuity of the OPEN JOIST 2000® products also aiming for your "Peace of mind underfoot™"!

Identification

14" OJ318

Grades: 14 = 1.4E
15 = 1.5E
18 = 1.8E
20 = 2,0E

Flange: 2X3"
2X4"

Depths: 9 ½"
11 ⅞"
14"
16"



Design Values

OJ Series Reference Design Properties

Allowable Stress Design (ASD)

Series	Depth	Flange Width	Ma	Va	EI	K	Joist Weight
	Inches	Inches	(lbs-ft)	(lbs)	El (x10 ⁶ lb/in ²)	(x 10 ⁶ lbs)	plf
OJ-314	9.5	2.5	2344	945	170	2,7	2.70
	11.875	2.5	3035	1100	285	3,7	2.80
	14	2.5	3635	1240	412	4,6	2.85
	16	2.5	4131	1373	554	5,5	2.95
OJ-315	9.5	2.5	2836	945	182	2,7	2.70
	11.875	2.5	3672	1100	305	3,7	2.80
	14	2.5	4420	1240	442	4,6	2.85
	16	2.5	5124	1373	594	5,5	2.95
OJ-318	9.5	2.5	3607	945	219	2,7	2.73
	11.875	2.5	4670	1100	366	3,7	2.83
	14	2.5	5621	1240	530	4,6	2.88
	16	2.5	6516	1373	712	5,5	2.98
OJ-320	9.5	2.5	3738	945	243	2,7	2.73
	11.875	2.5	4840	1100	407	3,7	2.83
	14	2.5	5826	1240	589	4,6	2.88
	16	2.5	6753	1373	791	5,5	2.98
OJ-414	9.5	3.5	3339	945	238	3,3	3.23
	11.875	3.5	4324	1100	398	4,6	3.33
	14	3.5	5178	1240	577	5,7	3.43
	16	3.5	5884	1373	776	6,8	3.53
OJ-415	11.875	3.5	5231	1100	427	4,6	3.35
	14	3.5	6296	1240	618	5,7	3.45
OJ-418	9.5	3.5	5138	945	306	3,3	3.25
	11.875	3.5	6652	1100	512	4,6	3.35
	14	3.5	8007	1240	742	5,7	3.45
	16	3.5	9282	1373	997	6,8	3.55
OJ-420	9.5	3.5	5325	945	340	3,3	3.25
	11.875	3.5	6894	1100	569	4,6	3.35
	14	3.5	8298	1240	824	5,7	3.45
	16	3.5	9620	1373	1 108	6,8	3.55

- 1) The tabulated design properties are reference design values for normal duration load. Reference allowable design moment and shear properties, Ma and Va must be corrected in accordance with applicable code adjustment factors
- 2) Allowable moment capacity must not be increased by any repetitive member use factor.
- 3) Maximum deflection at mid-span is calculated as follows for a uniformly loaded joist.

$$\text{Deflection}(\Delta) = \frac{5wL^4}{384EI} + \frac{wL^2}{K}$$

Where:
 L = Span
 EI = Bending stiffness
 K = Shear deflection factor
 w = Uniform Load

Open Joist TriForce® Series Allowable Bearing Reactions

Series	Depth (in)	2x3 Block End (lbs)		OSB End (lbs)		
		1 ½"	3 ½"	1 ½"	1 ½" with web stiffeners	3 ½"
OJ-300 OJ-400	9.5	1 514	1 830	845	1 255	1 193
	11.875	1 581	1 951	890	1 320	1 250
	14	1 595	2 059	1 050	1 340	1 320
	16	1 595	2 160	1 070	1 360	1 350

- 1) Unless Otherwise indicated, the tabulated reaction values are for normal duration of load and are permitted to be increased for other load durations in accordance with applicable code adjustment factors. These values are also limited by flange perpendicular to grain bearing stress of 425 psi.
- 2) End reactions require a minimum bearing length of 1 ½" linear interpolation between bearing lengths is permitted.
- 3) A length of up to 24 inches may be removed from the OSB end without modification of the tabulated allowable design properties.
- 4) Web Stiffeners must be installed in accordance with guidelines presented in this guide.

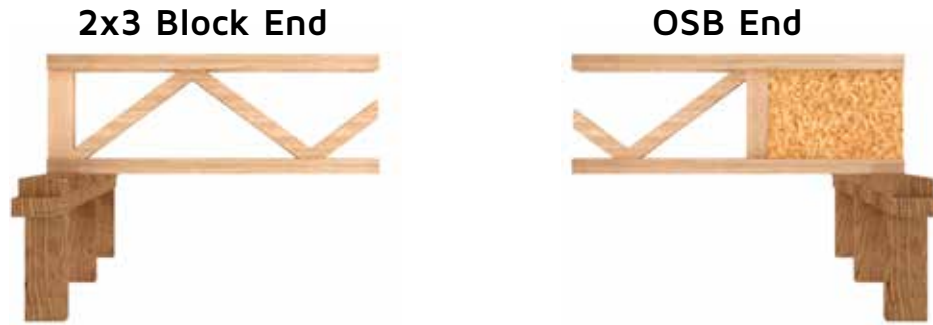

Stocking Lengths

Available Stocking Lengths

Open joist **TRIFORCE®** offers new dimensions in height and length. The new open joist **TRIFORCE®** is offered in standard sizes of the industry, 9 ½", 11 ⅞", 14" and 16". Open joist **TRIFORCE®** has a new material configuration system based on a 24" adjustable OSB panel end. The simplified material configuration system offers a more efficient and economical product to our distributors and loyal customers.

Depth	Series	Weight lbs/ft	Stock Lengths (feet)											
			8	10	12	14	16	18	20	22	24	26	28	30
9 ½	OJ314	2.70	×	×	×	×	×							
	OJ418	3.25						×						
11 ⅞	OJ314	2.80	×	×	×	×	×							
	OJ315	2.80						×						
	OJ415	3.35							×					
	OJ418	3.35								×				
14	OJ314	2.85	×	×	×	×	×							
	OJ315	2.85						×	×					
	OJ415	3.45								×				
	OJ418	3.45									×	×		
16	OJ314	2.95	×	×	×	×	×							
	OJ315	2.95						×	×					
	OJ418	3.55								×	×	×		
	OJ420	3.55											×	×

L/480 Span Chart

Maximum Allowed Floor Spans for residential application

Nailed & Glued Subfloor - Improved Criteria L/480

$$\Delta_L \leq L/480$$

9.5"			LL=40 psf DL=15 psf				LL=40 psf DL=30 psf			
Spacing o.c.			12"	16"	19.2"	24"	12"	16"	19.2"	24"
Subfloor thickness - CSP			5/8"	5/8"	5/8"	3/4"	5/8"	5/8"	5/8"	3/4"
Length	Series		Maximum Floor span c/c				Maximum Floor span c/c			
8'-0"	OJ314	2x3	8'-0"	8'-0"	8'-0"	8'-0"	8'-0"	8'-0"	8'-0"	8'-0"
10'-0"			10'-0"	10'-0"	10'-0"	10'-0"	10'-0"	10'-0"	10'-0"	10'-0"
12'-0"			12'-0"	12'-0"	12'-0"	12'-0"	12'-0"	12'-0"	12'-0"	11'-6"
14'-0"			14'-0"	14'-0"	13'-0"	14'-0"	14'-0"	12'-11"	-----	-----
16'-0"			16'-0"	15'-7"	14'-7"	-----	16'-0"	14'-2"	-----	-----
18'-0"	OJ418	2x4	18'-0"	18'-0"	17'-5"	16'-2"	18'-0"	18'-0"	17'-0"	-----

11.875"			LL=40 psf DL=15 psf				LL=40 psf DL=30 psf				
Spacing o.c.			12"	16"	19.2"	24"	12"	16"	19.2"	24"	
Subfloor thickness - CSP			5/8"	5/8"	5/8"	3/4"	5/8"	5/8"	5/8"	3/4"	
Length	Series		Maximum Floor span c/c				Maximum Floor span c/c				
8'-0"	OJ314	2x3	8'-0"	8'-0"	8'-0"	8'-0"	8'-0"	8'-0"	8'-0"	8'-0"	
10'-0"			10'-0"	10'-0"	10'-0"	10'-0"	10'-0"	10'-0"	10'-0"	10'-0"	
12'-0"			12'-0"	12'-0"	12'-0"	12'-0"	12'-0"	12'-0"	12'-0"	12'-0"	
14'-0"			14'-0"	14'-0"	14'-0"	14'-0"	14'-0"	14'-0"	14'-0"	13'-2"	-----
16'-0"			16'-0"	16'-0"	16'-0"	14'-10"	16'-0"	16'-0"	14'-8"	-----	-----
18'-0"	OJ315	2x3	18'-0"	18'-0"	17'-9"	16'-4"	18'-0"	17'-8"	16'-2"	-----	
	OJ418 (S)	2x4	18'-0"	18'-0"	18'-0"	18'-0"	18'-0"	18'-0"	18'-0"	17'-10"	
	OJ415	2x4	20'-0"	20'-0"	19'-9"	18'-4"	20'-0"	20'-0"	19'-3"	-----	
	OJ418 (S)	2x4	20'-0"	20'-0"	20'-0"	19'-4"	20'-0"	20'-0"	20'-0"	-----	
22'-0"	OJ418	2x4	22'-0"	22'-0"	20'-9"	-----	22'-0"	21'-7"	20'-4"	-----	

14"			LL=40 psf DL=15 psf				LL=40 psf DL=30 psf			
Spacing o.c.			12"	16"	19.2"	24"	12"	16"	19.2"	24"
Subfloor thickness - CSP			5/8"	5/8"	5/8"	3/4"	5/8"	5/8"	5/8"	3/4"
Length	Series		Maximum Floor span c/c				Maximum Floor span c/c			
8'-0"	OJ314	2x3	8'-0"	8'-0"	8'-0"	8'-0"	8'-0"	8'-0"	8'-0"	8'-0"
10'-0"			10'-0"	10'-0"	10'-0"	10'-0"	10'-0"	10'-0"	10'-0"	10'-0"
12'-0"			12'-0"	12'-0"	12'-0"	12'-0"	12'-0"	12'-0"	12'-0"	12'-0"
14'-0"			14'-0"	14'-0"	14'-0"	14'-0"	14'-0"	14'-0"	14'-0"	14'-0"
16'-0"			16'-0"	16'-0"	16'-0"	16'-0"	16'-0"	16'-0"	16'-0"	14'-4"
18'-0"	OJ315	2x3	18'-0"	18'-0"	18'-0"	17'-11"	18'-0"	18'-0"	17'-9"	-----
	OJ315	2x3	20'-0"	20'-0"	20'-0"	-----	20'-0"	19'-5"	-----	-----
	OJ418 (S)	2x4	20'-0"	20'-0"	20'-0"	20'-0"	20'-0"	20'-0"	20'-0"	18'-11"
22'-0"	OJ415	2x4	22'-0"	22'-0"	22'-0"	20'-11"	22'-0"	22'-0"	21'-2"	-----
24'-0"	OJ418	2x4	24'-0"	24'-0"	23'-7"	-----	24'-0"	24'-0"	23'-1"	-----
26'-0"			26'-0"	25'-0"	-----	-----	26'-0"	24'-6"	-----	-----

16"			LL=40 psf DL=15 psf				LL=40 psf DL=30 psf			
Spacing o.c.			12"	16"	19.2"	24"	12"	16"	19.2"	24"
Subfloor thickness - CSP			5/8"	5/8"	5/8"	3/4"	5/8"	5/8"	5/8"	3/4"
Length	Series		Maximum Floor span c/c				Maximum Floor span c/c			
8'-0"	OJ314	2x3	8'-0"	8'-0"	8'-0"	8'-0"	8'-0"	8'-0"	8'-0"	8'-0"
10'-0"			10'-0"	10'-0"	10'-0"	10'-0"	10'-0"	10'-0"	10'-0"	10'-0"
12'-0"			12'-0"	12'-0"	12'-0"	12'-0"	12'-0"	12'-0"	12'-0"	12'-0"
14'-0"			14'-0"	14'-0"	14'-0"	14'-0"	14'-0"	14'-0"	14'-0"	14'-0"
16'-0"			OJ314	2x3	16'-0"	16'-0"	16'-0"	16'-0"	16'-0"	16'-0"
	OJ318 (S)	2x3	16'-0"	16'-0"	16'-0"	16'-0"	16'-0"	16'-0"	16'-0"	16'-0"
18'-0"	OJ315	2x3	18'-0"	18'-0"	18'-0"	18'-0"	18'-0"	18'-0"	18'-0"	17'-1"
	OJ318 (S)	2x3	18'-0"	18'-0"	18'-0"	18'-0"	18'-0"	18'-0"	18'-0"	18'-0"
	OJ315	2x3	20'-0"	20'-0"	20'-0"	19'-3"	20'-0"	20'-0"	19'-1"	-----
	OJ418 (S)	2x4	20'-0"	20'-0"	20'-0"	20'-0"	20'-0"	20'-0"	20'-0"	19'-2"
22'-0"	OJ418	2x4	22'-0"	22'-0"	22'-0"	22'-0"	22'-0"	22'-0"	22'-0"	-----
24'-0"			24'-0"	24'-0"	24'-0"	24'-0"	24'-0"	24'-0"	24'-0"	-----
26'-0"			26'-0"	26'-0"	26'-0"	24'-2"	26'-0"	26'-0"	24'-1"	-----
28'-0"			28'-0"	28'-0"	26'-10"	-----	28'-0"	27'-11"	-----	-----
30'-0"			30'-0"	28'-6"	-----	-----	30'-0"	-----	-----	-----

Notes :

- Spans apply to simple span application only.
- Minimum end bearing length is 1 1/2", **except for bold spans minimum 1 1/2" at the OSB section with web stiffeners.**
- Maximum spans are measured **centerline to centerline** of bearing and are based on uniformly loaded joists.
- Dead load deflection is limited to L/240 and Total load deflection is limited to L/240.
- Live Load is limited to **L/480**.
- The spans shown consider a minimum 5/8" thick rated sheathing nailed and glued to joist in accordance with the applicable code or a 3/4" at 24" o.c.
- Allowable spans take into consideration the composite effect from glued and nailed subfloor for deflections.
- Refer to appropriate sections of the Specifier Guide for installation guidelines and construction details.
- The nailing specifications are to be in accordance with in force building code and the adhesives used should comply with APA Specification AFG-01 or ASTM D3498.
- (S) = Special grade, verify availability.

L/360 Span Chart

Maximum Allowed Floor Spans for residential application

Nailed & Glued Subfloor - Improved Criteria L/360

$$\Delta_L \leq L/360$$

9.5"			LL=40 psf DL=15 psf				LL=40 psf DL=30 psf			
Spacing o.c.			12"	16"	19.2"	24"	12"	16"	19.2"	24"
Subfloor thickness - CSP			5/8"	5/8"	5/8"	3/4"	5/8"	5/8"	5/8"	3/4"
Length	Series		Maximum Floor span c/c				Maximum Floor span c/c			
8'-0"	OJ314	2x3	8'-0"	8'-0"	8'-0"	8'-0"	8'-0"	8'-0"	8'-0"	8'-0"
10'-0"			10'-0"	10'-0"	10'-0"	10'-0"	10'-0"	10'-0"	10'-0"	
12'-0"			12'-0"	12'-0"	12'-0"	12'-0"	12'-0"	12'-0"	11'-6"	
14'-0"			14'-0"	14'-0"	13'-0"	14'-0"	14'-0"	12'-11"	-----	
16'-0"			16'-0"	15'-11"	14'-7"	-----	16'-0"	14'-2"	-----	
18'-0"	OJ418	2x4	18'-0"	18'-0"	18'-0"	17'-9"	18'-0"	18'-0"	17'-0"	-----

11.875"			LL=40 psf DL=15 psf				LL=40 psf DL=30 psf			
Spacing o.c.			12"	16"	19.2"	24"	12"	16"	19.2"	24"
Subfloor thickness - CSP			5/8"	5/8"	5/8"	3/4"	5/8"	5/8"	5/8"	3/4"
Length	Series		Maximum Floor span c/c				Maximum Floor span c/c			
8'-0"	OJ314	2x3	8'-0"	8'-0"	8'-0"	8'-0"	8'-0"	8'-0"	8'-0"	8'-0"
10'-0"			10'-0"	10'-0"	10'-0"	10'-0"	10'-0"	10'-0"	10'-0"	
12'-0"			12'-0"	12'-0"	12'-0"	12'-0"	12'-0"	12'-0"	12'-0"	
14'-0"			14'-0"	14'-0"	14'-0"	14'-0"	14'-0"	14'-0"	13'-2"	
16'-0"			16'-0"	16'-0"	14'-10"	16'-0"	16'-0"	16'-0"	14'-8"	
18'-0"	OJ315	2x3	18'-0"	18'-0"	18'-0"	16'-4"	18'-0"	17'-8"	16'-2"	-----
	OJ418 (S)	2x4	18'-0"	18'-0"	18'-0"	18'-0"	18'-0"	18'-0"	18'-0"	17'-10"
	OJ415	2x4	20'-0"	20'-0"	20'-0"	19'-6"	20'-0"	20'-0"	19'-3"	-----
	OJ418 (S)	2x4	20'-0"	20'-0"	20'-0"	20'-0"	20'-0"	20'-0"	20'-0"	-----
22'-0"	OJ418	2x4	22'-0"	22'-0"	22'-0"	21'-2"	22'-0"	21'-7"	20'-4"	-----

14"			LL=40 psf DL=15 psf				LL=40 psf DL=30 psf			
Spacing o.c.			12"	16"	19.2"	24"	12"	16"	19.2"	24"
Subfloor thickness - CSP			5/8"	5/8"	5/8"	3/4"	5/8"	5/8"	5/8"	3/4"
Length	Series		Maximum Floor span c/c				Maximum Floor span c/c			
8'-0"	OJ314	2x3	8'-0"	8'-0"	8'-0"	8'-0"	8'-0"	8'-0"	8'-0"	8'-0"
10'-0"			10'-0"	10'-0"	10'-0"	10'-0"	10'-0"	10'-0"	10'-0"	
12'-0"			12'-0"	12'-0"	12'-0"	12'-0"	12'-0"	12'-0"	12'-0"	
14'-0"			14'-0"	14'-0"	14'-0"	14'-0"	14'-0"	14'-0"	14'-0"	
16'-0"			16'-0"	16'-0"	16'-0"	16'-0"	16'-0"	16'-0"	14'-4"	
18'-0"	OJ315	2x3	18'-0"	18'-0"	18'-0"	17'-11"	18'-0"	18'-0"	17'-9"	-----
20'-0"	OJ315	2x3	20'-0"	20'-0"	20'-0"	-----	20'-0"	19'-5"	-----	-----
	OJ418 (S)	2x4	20'-0"	20'-0"	20'-0"	20'-0"	20'-0"	20'-0"	20'-0"	18'-11"
22'-0"	OJ415	2x4	22'-0"	22'-0"	22'-0"	21'-4"	22'-0"	22'-0"	21'-2"	-----
24'-0"	OJ418	2x4	24'-0"	24'-0"	24'-0"	24'-0"	24'-0"	24'-0"	23'-1"	-----
26'-0"			26'-0"	26'-0"	25'-9"	24'-1"	26'-0"	24'-6"	-----	-----

16"			LL=40 psf DL=15 psf				LL=40 psf DL=30 psf			
Spacing o.c.			12"	16"	19.2"	24"	12"	16"	19.2"	24"
Subfloor thickness - CSP			5/8"	5/8"	5/8"	3/4"	5/8"	5/8"	5/8"	3/4"
Length	Series		Maximum Floor span c/c				Maximum Floor span c/c			
8'-0"	OJ314	2x3	8'-0"	8'-0"	8'-0"	8'-0"	8'-0"	8'-0"	8'-0"	8'-0"
10'-0"			10'-0"	10'-0"	10'-0"	10'-0"	10'-0"	10'-0"	10'-0"	
12'-0"			12'-0"	12'-0"	12'-0"	12'-0"	12'-0"	12'-0"	12'-0"	
14'-0"			14'-0"	14'-0"	14'-0"	14'-0"	14'-0"	14'-0"	14'-0"	
16'-0"			OJ314	2x3	16'-0"	16'-0"	16'-0"	16'-0"	16'-0"	16'-0"
	OJ318 (S)	2x3	16'-0"	16'-0"	16'-0"	16'-0"	16'-0"	16'-0"	16'-0"	16'-0"
18'-0"	OJ315	2x3	18'-0"	18'-0"	18'-0"	18'-0"	18'-0"	18'-0"	18'-0"	17'-1"
	OJ318 (S)	2x3	18'-0"	18'-0"	18'-0"	18'-0"	18'-0"	18'-0"	18'-0"	18'-0"
20'-0"	OJ315	2x3	20'-0"	20'-0"	20'-0"	19'-3"	20'-0"	20'-0"	19'-1"	-----
	OJ418 (S)	2x4	20'-0"	20'-0"	20'-0"	20'-0"	20'-0"	20'-0"	20'-0"	19'-2"
22'-0"	OJ418	2x4	22'-0"	22'-0"	22'-0"	22'-0"	22'-0"	22'-0"	22'-0"	-----
24'-0"			24'-0"	24'-0"	24'-0"	24'-0"	24'-0"	24'-0"	24'-0"	-----
26'-0"			26'-0"	26'-0"	26'-0"	24'-2"	26'-0"	26'-0"	24'-1"	-----
28'-0"			28'-0"	28'-0"	28'-0"	-----	28'-0"	27'-11"	-----	-----
30'-0"			30'-0"	30'-0"	29'-4"	-----	30'-0"	-----	-----	-----

Notes :

- Spans apply to simple span application only.
- Minimum end bearing length is 1½", **except for bold spans minimum 1½" at the OSB section with web stiffeners.**
- Maximum spans are measured **centerline to centerline** of bearing and are based on uniformly loaded joists.
- Dead load deflection is limited to L/240 and Total load deflection is limited to L/240.
- Live Load is limited to **L/360**.
- The spans shown consider a minimum 5/8" thick rated sheathing nailed and glued to joist in accordance with the applicable code or a 3/4" at 24" o.c.
- Allowable spans take into consideration the composite effect from glued and nailed subfloor for deflections.
- Refer to appropriate sections of the Specifier Guide for installation guidelines and construction details.
- The nailing specifications are to be in accordance with in force building code and the adhesives used should comply with APA Specification AFG-01 or ASTM D3498.
- (S) = Special grade, verify availability.

L/480 Load Chart

Maximum Allowed Live Load Chart for residential application

Glued & Nailed Subfloor with Continuous Strongbacks at Mid Span

$$\Delta_L \leq L/480$$

9.5"			Dead loads: 15 psf				Dead loads: 30 psf			
Spacing o.c.			12"	16"	19.2"	24"	12"	16"	19.2"	24"
Subfloor thickness - CSP			5/8"	5/8"	5/8"	3/4"	5/8"	5/8"	5/8"	3/4"
Length	Series		Maximum Live Load (psf)				Maximum Live Load (psf)			
8'-0"	OJ314	2x3	282	211	174	136	272	196	158	121
10'-0"			167	128	105	81	162	114	90	66
12'-0"			106	81	68	51	102	69	53	----
14'-0"			70	54	45	----	67	43	----	----
16'-0"			49	----	----	----	44	----	----	----
18'-0"	OJ418	2x4	57	44	----	----	57	43	----	----

11.875"			Dead loads: 15 psf				Dead loads: 30 psf			
Spacing o.c.			12"	16"	19.2"	24"	12"	16"	19.2"	24"
Subfloor thickness - CSP			5/8"	5/8"	5/8"	3/4"	5/8"	5/8"	5/8"	3/4"
Length	Series		Maximum Live Load (psf)				Maximum Live Load (psf)			
8'-0"	OJ314	2x3	314	232	191	149	299	217	176	134
10'-0"			233	171	140	109	218	156	125	94
12'-0"			157	114	92	71	142	99	77	56
14'-0"			111	79	63	48	96	64	48	----
16'-0"			79	57	45	----	66	42	----	----
18'-0"	OJ315	2x3	60	46	----	----	60	----	----	
	OJ418 (S)	2x4	92	71	60	49	92	71	58	----
	OJ415	2x4	60	46	----	----	60	46	----	
20'-0"	OJ418 (S)	2x4	69	53	45	----	69	53	45	----
22'-0"	OJ418	2x4	53	41	----	----	53	----	----	

14"			Dead loads: 15 psf				Dead loads: 30 psf			
Spacing o.c.			12"	16"	19.2"	24"	12"	16"	19.2"	24"
Subfloor thickness - CSP			5/8"	5/8"	5/8"	3/4"	5/8"	5/8"	5/8"	3/4"
Length	Series		Maximum Live Load (psf)				Maximum Live Load (psf)			
8'-0"	OJ314	2x3	319	236	194	152	304	221	179	137
10'-0"			252	185	152	118	237	170	137	104
12'-0"			191	139	113	88	176	124	98	73
14'-0"			136	98	79	60	121	83	64	45
16'-0"			100	71	57	42	85	56	42	----
18'-0"	OJ315	2x3	84	65	54	----	80	53	----	
	OJ315	2x3	63	49	40	----	59	----	----	
20'-0"	OJ418 (S)	2x4	98	75	63	----	98	70	58	
22'-0"	OJ415	2x4	65	50	42	----	65	48	----	
24'-0"	OJ418	2x4	59	45	----	----	59	45	----	
26'-0"			47	----	----	----	47	----	----	

16"			Dead loads: 15 psf				Dead loads: 30 psf			
Spacing o.c.			12"	16"	19.2"	24"	12"	16"	19.2"	24"
Subfloor thickness - CSP			5/8"	5/8"	5/8"	3/4"	5/8"	5/8"	5/8"	3/4"
Length	Series		Maximum Live Load (psf)				Maximum Live Load (psf)			
8'-0"	OJ314	2x3	324	239	197	154	309	224	182	139
10'-0"			256	188	154	120	241	173	139	105
12'-0"			211	154	126	98	196	139	111	83
14'-0"			156	113	92	70	141	98	77	55
16'-0"			OJ314	2x3	116	83	66	50	101	68
	OJ318 (S)	2x3	154	112	90	69	139	97	76	
	OJ315	2x3	111	81	65	49	98	66	50	
18'-0"	OJ318 (S)	2x3	127	99	79	60	121	83	64	
	OJ315	2x3	83	62	49	----	73	47	----	
20'-0"	OJ418 (S)	2x4	120	86	69	52	105	71	54	
22'-0"	OJ418	2x4	99	76	62	46	93	62	47	
24'-0"			78	60	50	41	78	54	40	
26'-0"			62	48	40	----	62	48	----	
28'-0"	OJ420	2x4	55	42	----	----	55	----		
30'-0"			46	----	----	----	46	----		

Notes :

- Uniform loads shown are for Full span (bearing included), higher loads could be applied using longer end bearing length.
- Minimum end bearing length is 1½", **except for bold loads, minimum 1½" with web stiffeners at the OSB section.**
- Dead load deflection is limited to L/240 and Total load deflection is limited to L/240.
- Live load deflection is limited to **L/480**.
- Refer to appropriate sections of the Specifier Guide for installation guidelines and construction details.
- The nailing specifications are to be in accordance with in force building code and the adhesives used should comply with APA Specification AFG-01 or ASTM D3498.
- (S) = Special grade, verify availability.

L/360 Load Chart

Maximum Allowed Live Load Chart for residential application

Glued & Nailed Subfloor with Continuous Strongbacks at Mid Span

$$\Delta_L \leq L/360$$

9.5"			Dead loads: 15 psf				Dead loads: 30 psf			
Spacing o.c.			12"	16"	19.2"	24"	12"	16"	19.2"	24"
Subfloor thickness - CSP			5/8"	5/8"	5/8"	3/4"	5/8"	5/8"	5/8"	3/4"
Length	Series		Maximum Live Load (psf)				Maximum Live Load (psf)			
8'-0"	OJ314	2x3	287	211	174	136	272	196	158	121
10'-0"			177	129	105	81	162	114	90	66
12'-0"			117	84	68	51	102	69	53	----
14'-0"			82	58	45	----	67	43	----	----
16'-0"			59	40	----	----	44	----	----	----
18'-0"	OJ418	2x4	76	59	50	----	70	43	----	----

11.875"			Dead loads: 15 psf				Dead loads: 30 psf			
Spacing o.c.			12"	16"	19.2"	24"	12"	16"	19.2"	24"
Subfloor thickness - CSP			5/8"	5/8"	5/8"	3/4"	5/8"	5/8"	5/8"	3/4"
Length	Series		Maximum Live Load (psf)				Maximum Live Load (psf)			
8'-0"	OJ314	2x3	314	232	191	149	299	217	176	134
10'-0"			233	171	140	109	218	156	125	94
12'-0"			157	114	92	71	142	99	77	56
14'-0"			111	79	63	48	96	64	48	----
16'-0"			81	57	45	----	66	42	----	----
18'-0"	OJ315	2x3	76	53	42	----	61	----	----	
	OJ418 (S)	2x4	123	91	73	55	111	76	58	40
	OJ415	2x4	81	62	51	----	75	48	----	----
20'-0"	OJ418 (S)	2x4	93	72	61	47	92	62	45	----
22'-0"	OJ418	2x4	71	54	46	----	62	----	----	----

14"			Dead loads: 15 psf				Dead loads: 30 psf			
Spacing o.c.			12"	16"	19.2"	24"	12"	16"	19.2"	24"
Subfloor thickness - CSP			5/8"	5/8"	5/8"	3/4"	5/8"	5/8"	5/8"	3/4"
Length	Series		Maximum Live Load (psf)				Maximum Live Load (psf)			
8'-0"	OJ314	2x3	319	236	194	152	304	221	179	137
10'-0"			252	185	152	118	237	170	137	104
12'-0"			191	139	113	88	176	124	98	73
14'-0"			136	98	79	60	121	83	64	45
16'-0"			100	71	57	42	85	56	42	----
18'-0"	OJ315	2x3	95	68	54	40	80	53	----	----
	OJ315	2x3	74	52	40	----	59	----	----	----
20'-0"	OJ418 (S)	2x4	119	85	68	52	104	70	53	----
22'-0"	OJ415	2x4	80	63	50	----	65	48	----	----
24'-0"	OJ418	2x4	79	61	51	----	74	46	----	----
26'-0"			63	48	----	----	50	----	----	----

16"			Dead loads: 15 psf				Dead loads: 30 psf			
Spacing o.c.			12"	16"	19.2"	24"	12"	16"	19.2"	24"
Subfloor thickness - CSP			5/8"	5/8"	5/8"	3/4"	5/8"	5/8"	5/8"	3/4"
Length	Series		Maximum Live Load (psf)				Maximum Live Load (psf)			
8'-0"	OJ314	2x3	324	239	197	154	309	224	182	139
10'-0"			256	188	154	120	241	173	139	105
12'-0"			211	154	126	98	196	139	111	83
14'-0"			156	113	92	70	141	98	77	55
16'-0"			OJ314	2x3	116	83	66	50	101	68
	OJ318 (S)	2x3	154	112	90	69	139	97	76	54
	OJ315	2x3	113	81	65	49	98	66	50	----
18'-0"	OJ318 (S)	2x3	136	98	79	60	121	83	64	45
	OJ315	2x3	88	62	49	----	73	47	----	----
20'-0"	OJ418 (S)	2x4	120	86	69	52	105	71	54	----
	OJ418	2x4	108	77	62	46	93	62	47	----
24'-0"			98	69	55	41	83	54	40	----
26'-0"			83	63	50	----	74	48	----	----
28'-0"	OJ420	2x4	74	57	45	----	66	40	----	----
30'-0"			61	47	----	----	47	----	----	----

Notes :

- 1) Uniform loads shown are for Full span (bearing included), higher loads could be applied using longer end bearing length.
- 2) Minimum end bearing length is 1½", **except for bold loads, minimum 1½" with web stiffeners at the OSB section.**
- 3) Dead load deflection is limited to L/240 and Total load deflection is limited to L/240.
- 4) Live load deflection is limited to **L/360.**
- 5) Refer to appropriate sections of the Specifier Guide for installation guidelines and construction details.
- 6) The nailing specifications are to be in accordance with in force building code and the adhesives used should comply with APA Specification AFG-01 or ASTM D3498.
- 7) (S) = Special grade, verify availability.

Strongback Recommendation Chart

Mid Span Continuous Strongbacks Recommendation For Maximum Span Charts

9.5"			LL=40 psf DL=15 psf				LL=40 psf DL=30 psf					
Spacing o.c.			12"	16"	19.2"	24"	12"	16"	19.2"	24"		
Subfloor thickness - CSP			5/8"	5/8"	5/8"	3/4"	5/8"	5/8"	5/8"	3/4"		
Length	Series		Strongbacks				Strongbacks					
8'-0"	OJ314	2x3	None	None	None	None	None	None	None	None	None	
10'-0"			None	None	None	None	None	None	None	None	None	
12'-0"			None	None	None	None	None	None	None	None	None	
14'-0"			None	None	1-2x4	None	None	None	None	None	None	----
16'-0"			1-2x4	2-2x4	1-2x4	----	1-2x4	1-2x4	----	----	----	
18'-0"	OJ418	2x4	2-2x4	1-2x6	2-2x6	2-2x6	2-2x4	1-2x6	1-2x6	----		

11.875"			LL=40 psf DL=15 psf				LL=40 psf DL=30 psf				
Spacing o.c.			12"	16"	19.2"	24"	12"	16"	19.2"	24"	
Subfloor thickness - CSP			5/8"	5/8"	5/8"	3/4"	5/8"	5/8"	5/8"	3/4"	
Length	Series		Strongbacks				Strongbacks				
8'-0"	OJ314	2x3	None	None	None	None	None	None	None	None	None
10'-0"			None	None	None	None	None	None	None	None	None
12'-0"			None	None	None	None	None	None	None	None	None
14'-0"			None	None	None	None	None	None	None	None	None
16'-0"			None	1-2x4	1-2x4	None	None	None	None	1-2x4	----
18'-0"	OJ315	2x3	1-2x4	1-2x6	1-2x6	1-2x6	1-2x4	2-2x4	1-2x6	----	
	OJ418 (S)	2x4	None	1-2x4	1-2x4	2-2x4	None	1-2x4	1-2x4	2-2x4	
	OJ415	2x4	2-2x4	1-2x6	2-2x6	1-2x8	2-2x4	1-2x6	1-2x6	----	
	OJ418 (S)	2x4	1-2x4	1-2x6	2-2x6	2-2x6	1-2x6	1-2x6	1-2x6	----	
22'-0"	OJ418	2x4	1-2x6	2-2x6	1-2x8	2-2x8	1-2x6	2-2x6	2-2x6	----	

14"			LL=40 psf DL=15 psf				LL=40 psf DL=30 psf				
Spacing o.c.			12"	16"	19.2"	24"	12"	16"	19.2"	24"	
Subfloor thickness - CSP			5/8"	5/8"	5/8"	3/4"	5/8"	5/8"	5/8"	3/4"	
Length	Series		Strongbacks				Strongbacks				
8'-0"	OJ314	2x3	None	None	None	None	None	None	None	None	None
10'-0"			None	None	None	None	None	None	None	None	None
12'-0"			None	None	None	None	None	None	None	None	None
14'-0"			None	None	None	None	None	None	None	None	None
16'-0"			None	None	None	None	None	None	None	None	None
18'-0"	OJ315	2x3	None	1-2x6	1-2x6	1-2x6	None	1-2x6	1-2x6	----	
	OJ315	2x3	1-2x6	1-2x6	1-2x6	----	1-2x6	1-2x6	----	----	
	OJ418 (S)	2x4	None	1-2x6	1-2x6	1-2x6	1-2x6	1-2x6	1-2x6	1-2x6	
22'-0"	OJ415	2x4	1-2x6	1-2x6	2-2x6	2-2x6	1-2x6	1-2x6	2-2x6	----	
24'-0"	OJ418	2x4	1-2x6	2-2x6	2-2x8	2-2x8	1-2x6	2-2x6	2-2x6	----	
26'-0"			2-2x6	2-2x8	2-2x10	2-2x8	2-2x6	1-2x8	----	----	

16"			LL=40 psf DL=15 psf				LL=40 psf DL=30 psf				
Spacing o.c.			12"	16"	19.2"	24"	12"	16"	19.2"	24"	
Subfloor thickness - CSP			5/8"	5/8"	5/8"	3/4"	5/8"	5/8"	5/8"	3/4"	
Length	Series		Strongbacks				Strongbacks				
8'-0"	OJ314	2x3	None	None	None	None	None	None	None	None	None
10'-0"			None	None	None	None	None	None	None	None	None
12'-0"			None	None	None	None	None	None	None	None	None
14'-0"			None	None	None	None	None	None	None	None	None
16'-0"			OJ314	2x3	None	None	None	None	None	None	None
	OJ318 (S)	2x3	None	None	None	None	None	None	None	None	
18'-0"	OJ315	2x3	None	None	1-2x6	1-2x6	None	None	1-2x6	1-2x6	
	OJ318 (S)	2x3	None	None	None	None	None	None	1-2x6	1-2x6	
	OJ315	2x3	1-2x6	1-2x6	1-2x6	1-2x6	1-2x6	1-2x6	1-2x6	----	
	OJ418 (S)	2x4	None	None	1-2x6	1-2x6	1-2x6	1-2x6	1-2x6	1-2x6	
22'-0"	OJ418	2x4	None	1-2x6	1-2x6	1-2x6	1-2x6	1-2x6	1-2x6	1-2x6	----
24'-0"			1-2x6	1-2x6	2-2x6	2-2x6	1-2x6	1-2x6	2-2x6	----	
26'-0"			1-2x6	2-2x6	1-2x8	1-2x8	1-2x6	2-2x6	2-2x6	----	
28'-0"			2-2x6	2-2x8	2-2x8	----	2-2x6	2-2x8	----	----	
30'-0"			2-2x8	2-2x10	2-2x10	----	2-2x8	----	----	----	

Notes :

- 1) Specified continuous strongbacks installed at mid span shown, take into consideration a performance criterion.
- 2) Refer to appropriate sections of the Specifier Guide for installation guidelines and construction details.
- 3) Live load deflection is limited to L/360.
- 4) This table of continuous strongback for maximum spans can also be used for Maximum spans when live load deflection is limited to L/480.

Installation

1. Except for cutting length, **TRIFORCE**[®] flanges should never be cut, drilled or notched.
2. Install **TRIFORCE**[®] joists so that top and bottom flanges are within 1/2" of true vertical alignment.
3. At the ends, joists must be restrained to prevent rollover. Use rim board or blocking panels.
4. For Cantilevered **TRIFORCE**[®] joists, brace top and bottom flanges, and brace ends with closure panels, rim board.
5. Apply concentrated loads only on the top flange. Concentrated loads shall not be suspended from the bottom flange with the exception of light loads, such as ceiling fans or light fixtures.
6. **TRIFORCE**[®] must be protected from weather prior to installation.
7. Joists are to be used in dry conditions only.
8. Never install a damaged **TRIFORCE**[®] joist.
9. When strongbacks are installed, the strongbacks must be of dry lumber.
10. When a joist interferes with a plumbing pipe, the joist may be moved up to 3" to allow piping. OSB Panel End openings are allowed per the Allowable Hole through the OSB Panel End chart (see page 25). When moving a joist, check subfloor thickness with code requirements when joist spacing exceeds 19.2" o.c.
11. End bearing length must be at least 1 1/2".
12. To transfer loads from above, rim boards, squash blocks or blocking panels shall be used at exterior walls and interior bearing walls.
13. Joists shall not be in direct contact with masonry or concrete.
14. Install all bracing and sheathing to each **TRIFORCE**[®] joist before applying any construction loads on the floor system. Stack building material over beams or bearing walls only, otherwise additional shoring material may be needed.
15. Nails installed perpendicular to the wide face of the flange shall be spaced not closer than 2 1/2 inches o.c. for 8d common nails.
16. Details on the following pages show only **TRIFORCE**[®] specific fastener requirements. For other fastener requirements, see applicable building code.
17. The adhesives used for floor systems should comply to ASTM D3498-03 Standard Specification for Standard Specification for Adhesives for Field-Gluing Plywood to Lumber Framing for Floor Systems. Follow manufacturer guidelines for field-glued floors.

Not Permitted

Joist flanges shall not be notched, cut or drilled to allow piping

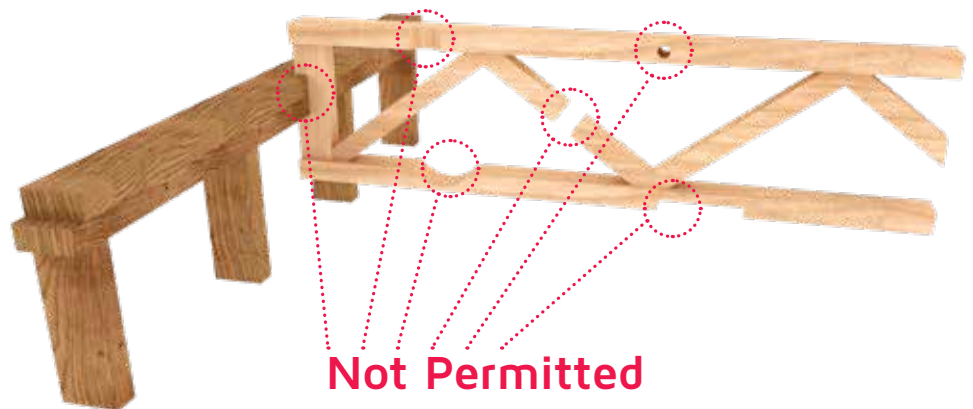

All information in this document is general and is given as general information to an informed tradesman, that must have all the proper qualifications and knowledge for installing floor joists properly as per manufacturers specifications and as per local code.

The warranty shall not extend to products misused, neglected, subjected to abnormal storage, use or exposure or which have been altered in any manner or not maintained in accordance with published instructions. The products must be handled and installed in accordance with the manufacturer's published instructions.

JOIST SPACING BELOW PLUMBING WALL PARALLEL TO WALL

Every third Joist may be shifted up to 3" to avoid plumbing penetration interference

Additional joists may be required (See Layout)

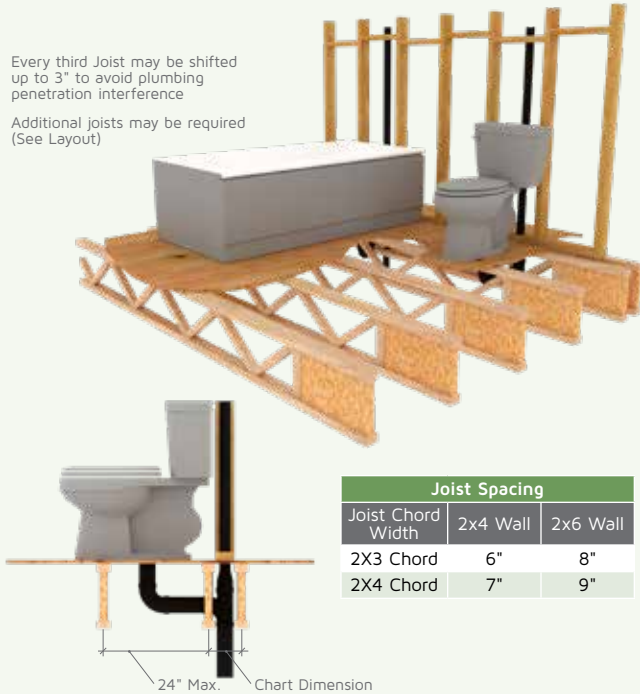

JOIST SPACING BELOW PLUMBING WALL PERPENDICULAR TO WALL

Every third Joist may be shifted up to 3" to avoid plumbing penetration interference

Additional joists may be required (See Layout)

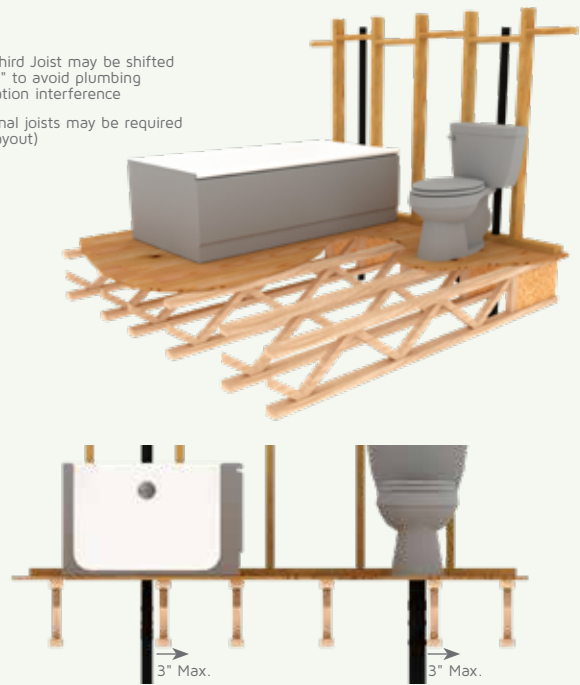

Storage & Handling

Storage Notes:

1. Keep **TRIFORCE**® bundles wrapped to protect from weather
2. Use wood stickers to separate bundles under each automatically inserted stickers.
3. Always store, stack and handle **TRIFORCE**® vertically and level – never flat/ horizontal.
4. Do not store **TRIFORCE**® in direct contact with the ground.
5. Store longest material lowest to the ground.
6. For optimal moisture protection, keep **TRIFORCE**® at least 6 inches up off the ground.
7. To protect from dirt and weather, delay unwrapping the **TRIFORCE**® bundles until the time of installation and delivery.
8. Take care to avoid forklift damage. If the ground is unlevel in the storage area, reduce forklift speed to avoid "bouncing" the load.
9. When handling with a crane, pick up the load using a spreader if necessary to minimize handling stresses. Keep **TRIFORCE**® vertical.
10. Maintain stack height within safe limits.
11. Do not lift **TRIFORCE**® joist by top flange.
12. Do not stack other material on top of **TRIFORCE**® bundles.
13. Bundle wrap can be slippery, especially when wet. Avoid walking on material.

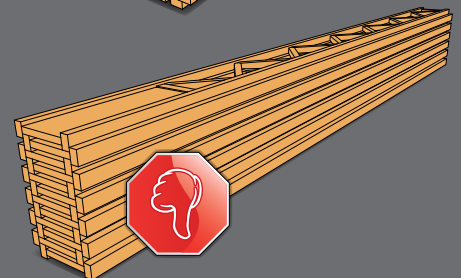
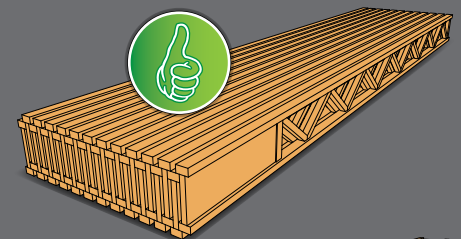
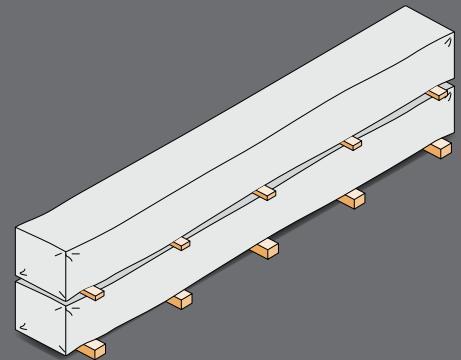

Typical Details

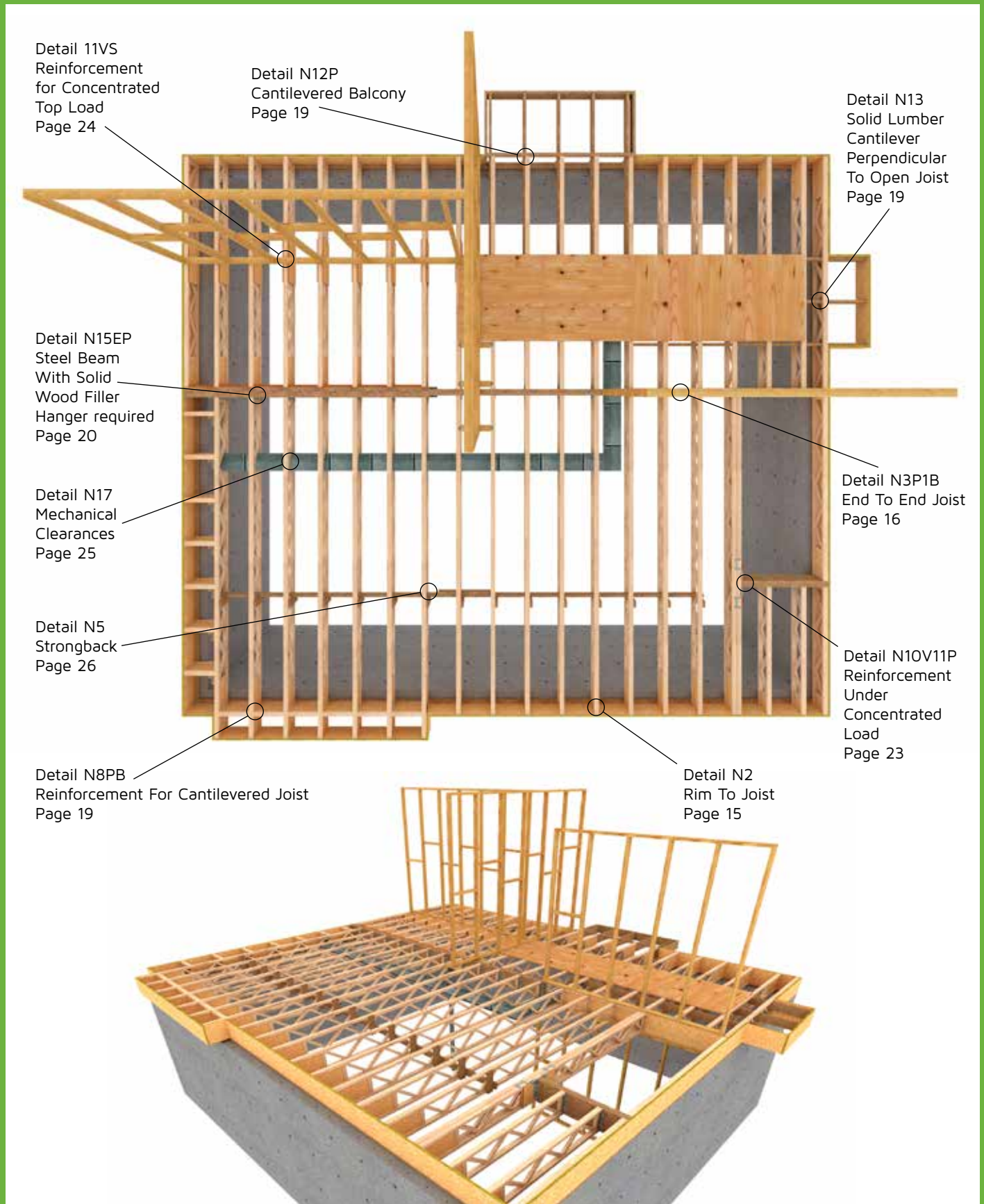

Rim Board Connection

Standard Sizes For Performance Rated Rim Boards

	Standard Sizes
Thickness (inches)	1 1/8
Depth (inches)	9 1/2, 11 3/8, 14, 16
Length (feet)	8 to 16



Design Capacities For Performance Rated Rim Board

Rim Board Grade	Performance Category	H (lb/ft)	V (lb/ft)			Z (lbf)	P (lbf)
		Depth Limitation (in.)					
		d ≤ 24	d ≤ 16	16 < d ≤ 24	d ≤ 24	16 < d ≤ 24	
Rim Board (C1)	1-1/8 or higher	180	4,400	3,000	350	3,500	
Rim Board Plus (B2)	1-1/8 or higher	200	4,850	3,200	350	3,500	

- These design values are applicable only to Rim Board applications in compliance with the connection requirements given in this document and shall not be used in the design of a bending member, such as joist, header, rafter, or ledger. All design values are applicable to the normal load duration. Design values may be adjusted for other load durations in accordance with the applicable code except that the bearing (vertical) load capacity (V) and concentrated vertical load capacity (P) are not permitted to be increased for any load durations shorter than the normal load duration. Toe-nailed connections are not limited by the 150 lb/ft lateral load capacity noted for Seismic Design Categories D, E and F in Section 2305.1.4 of the IBC.
- The performance categories for these rim boards refers to the minimum thickness of the rim board.
- H = The horizontal (shear) load transfer capacity.
- V = The bearing (vertical) load capacity, which shall not be adjusted for load durations in accordance with the applicable code.
- Z = The lateral resistance of a 1/2-inch-diameter log screw.
- P = The concentrated vertical load capacity based on 4-1/2-inch bearing length.

A Structural Rim Board is recommended when the open joist **TRIFORCE®** Floor Joists are installed perpendicular or parallel on exterior bearing walls.

It is not recommended to use open joist **TRIFORCE®** Floor Joists as solo starter joists on exterior bearing walls.

Rim to Joist

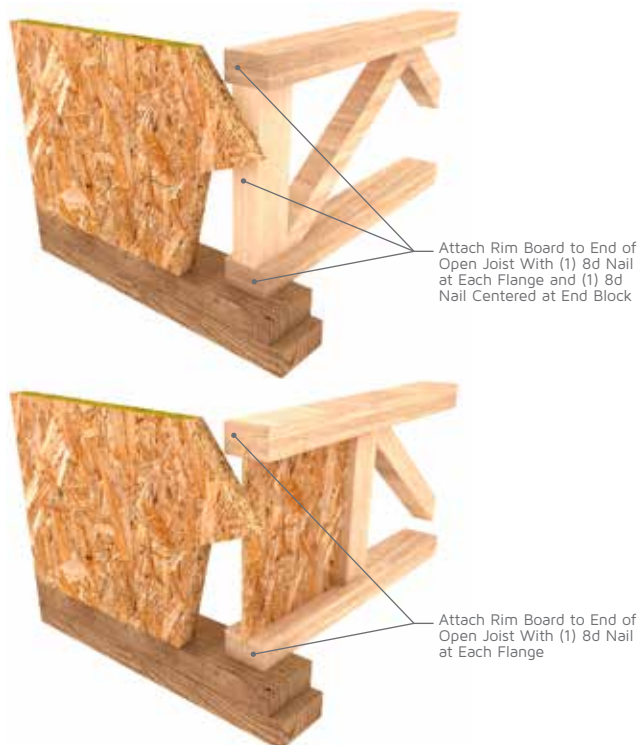

Toe-Nail Connection At Rim Board

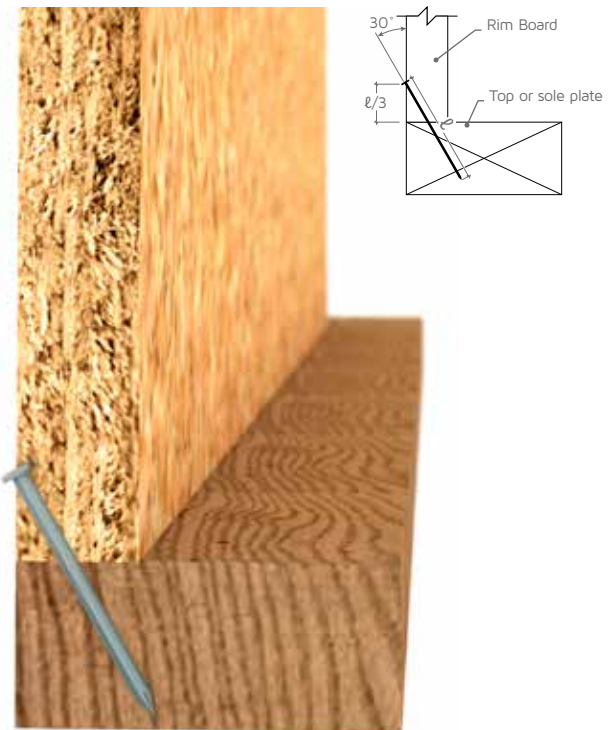

Interior Bearing Wall Blocking

Detail N3EP1M

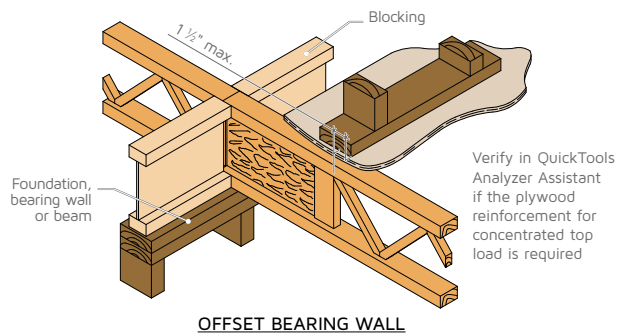

Detail N3EP2M

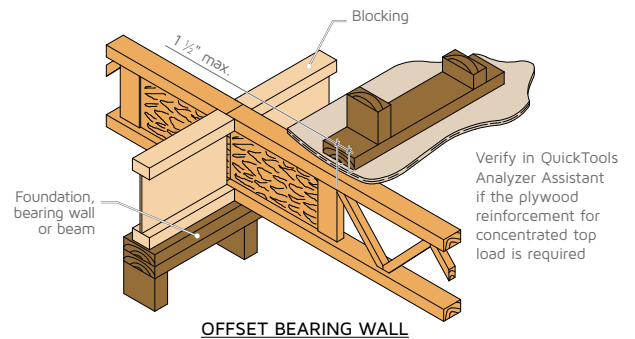

Detail N3P1B

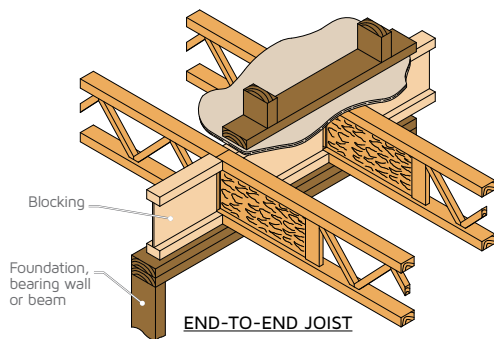

Detail N3P2B

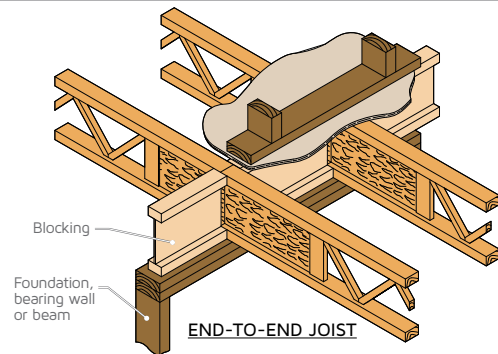

Parallel Non-Load Bearing Wall Support

When Non Load Bearing Walls above are installed parallel to the open joist TRIFORCE® below, two methods are recommended.

1. Add a supporting Joist under the Wall above.
2. Add 2x support or ladder bracing every 2' on center with Simpson Z28 clips as shown below or equivalent.



Model No.	Ga	Dimensions				Fasteners ¹ (Total)	Allowable ² Download (125)
		W	H	B	TF		
Z2	20	2 5/16	1 1/2	1 3/8	1 3/8	4-10dx1 1/2	465
Z4	12	1 1/2	3 1/2	2 1/8	1 3/4	2-16d	465
Z28	28	2 5/16	1 1/2	1 3/8	1 3/8	10dx1 1/2¹	—
Z38	28	2 5/16	2 1/2	1 3/8	1 3/8	10dx1 1/2 ¹	—
Z44	12	2 1/2	3 1/2	2	1 3/8	4-16d	865

- 1) Z28 and Z38 do not have nail holes. Fastener quantity and type shall be per Designer.
- 2) Allowable loads have been increased 25% for roof loading (Z clips), no further increase allowed, reduce where other loads govern.
- 3) Z4 loads apply with a nail into the top and a nail into the seat.
- 4) NAILS: 16d = 0,162" dia. x 3 1/2" long, 10dx1 1/2 = 0,148" dia. x 1 1/2" long. See other nail sizes and information

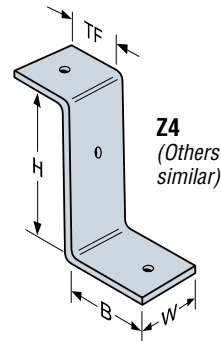

Perpendicular Blocking

Perpendicular I-Joist Blocking:

I-Joist perpendicular blocking or equivalent @ 24" on center. Attaching the Wood-I or I-Joist blocking with (2) 3 ½" (16d) nails to the top and bottom chords of the open joist **TRIFORCE**® and (1) 2 ½" (8d) nails through the Rim Board into the top and bottom chord of the I-Joist blocking. Secure the I-Joist blocking to the sole plate with (1) 3 ½" (10d) nails each side of the bottom chord.

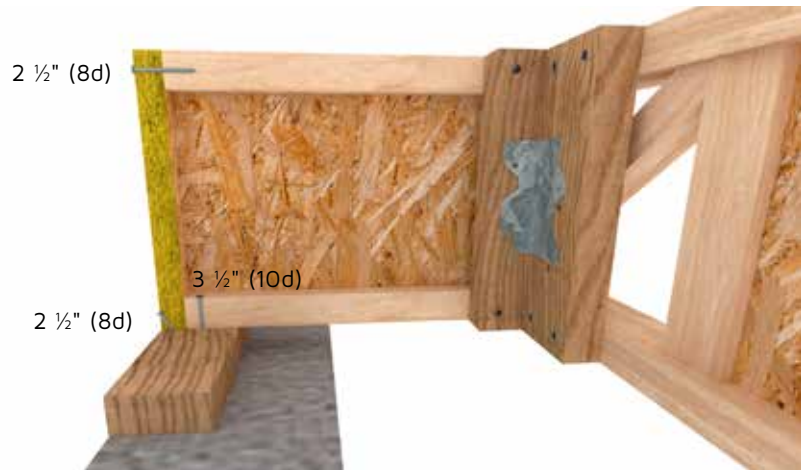

Detail N6R1B

PERPENDICULAR BLOCKING AT EXTERIOR WALL

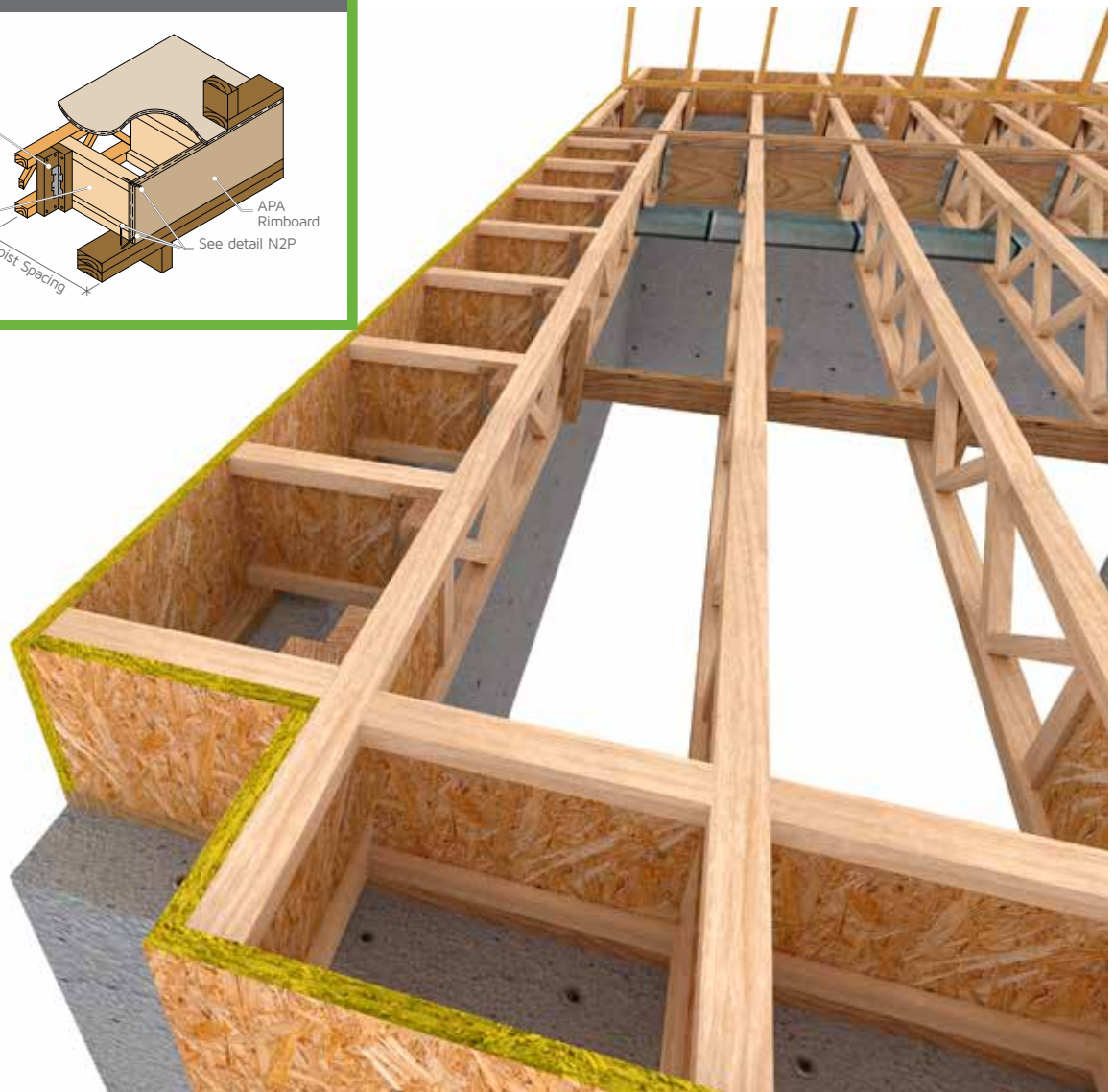
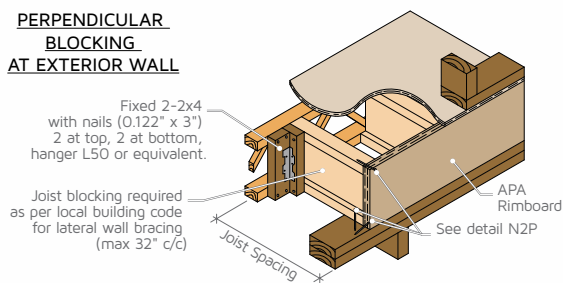

Cantilevers

Open joist **TRIFORCE**® Cantilevers can be applied to accommodate Balconies, Brick Ledge or Water Ledge or 2nd Story Wall support. Verification of loading will determine what type if any reinforcement may be required. Please consult your open joist **TRIFORCE**® Representative for any questions concerning cantilever situations.

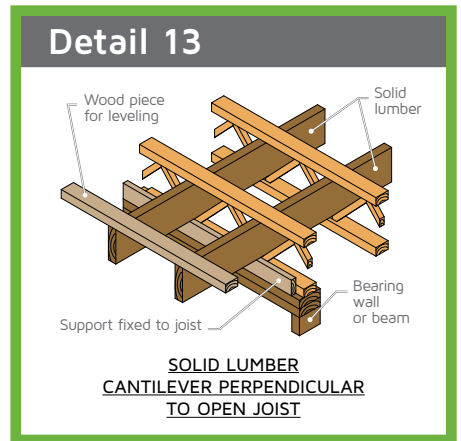
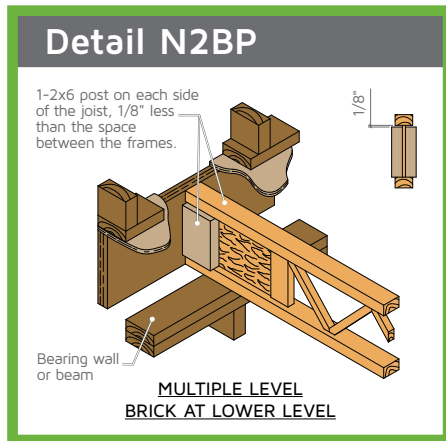
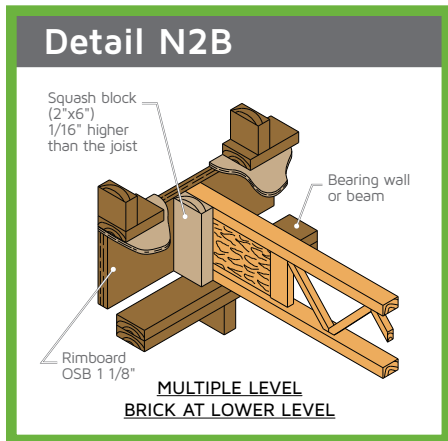
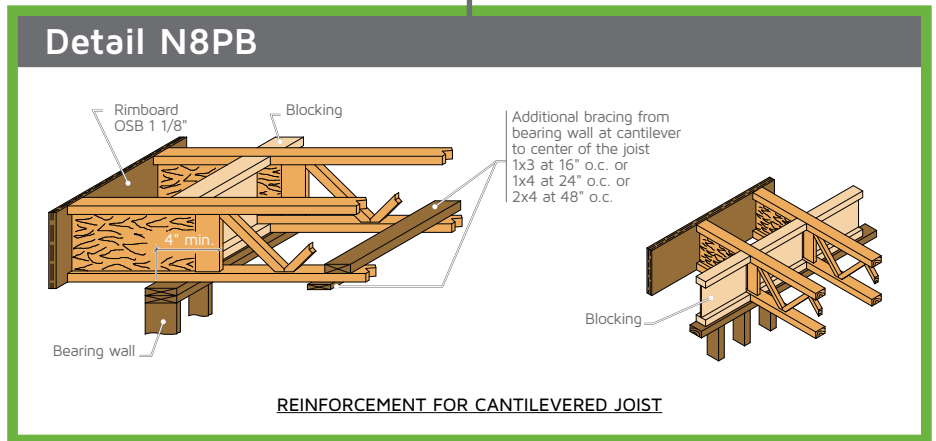
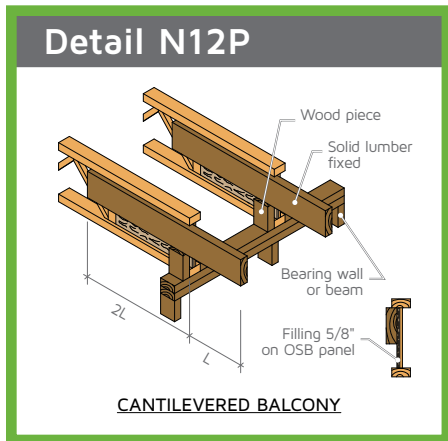

Steel Beam Connections with Hangers

Detail N15P1

**STEEL BEAM
WITH SOLID
WOOD FILLER
HANGER REQUIRED**

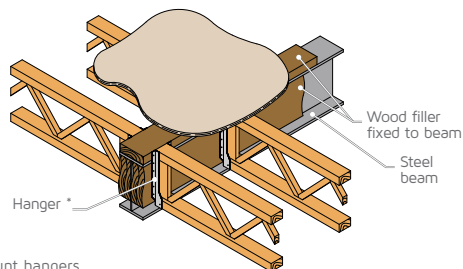

* top mount or face mount hangers

Detail N15EP

**STEEL BEAM
WITH SOLID
WOOD FILLER
HANGER REQUIRED**

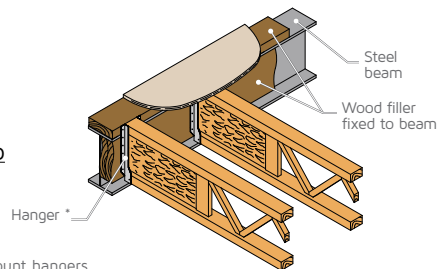

* top mount or face mount hangers



Steel Beam Connections without Hangers

Detail 14T

**STEEL BEAM
BOTTOM FLANGE
BEARING
HANGER
NOT REQUIRED**

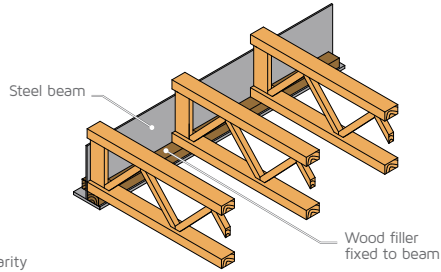

Blocking not shown for clarity

Detail N14P

**STEEL BEAM
BOTTOM FLANGE
BEARING
HANGER
NOT REQUIRED**

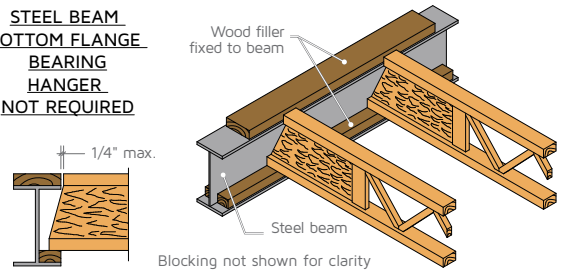

Blocking not shown for clarity

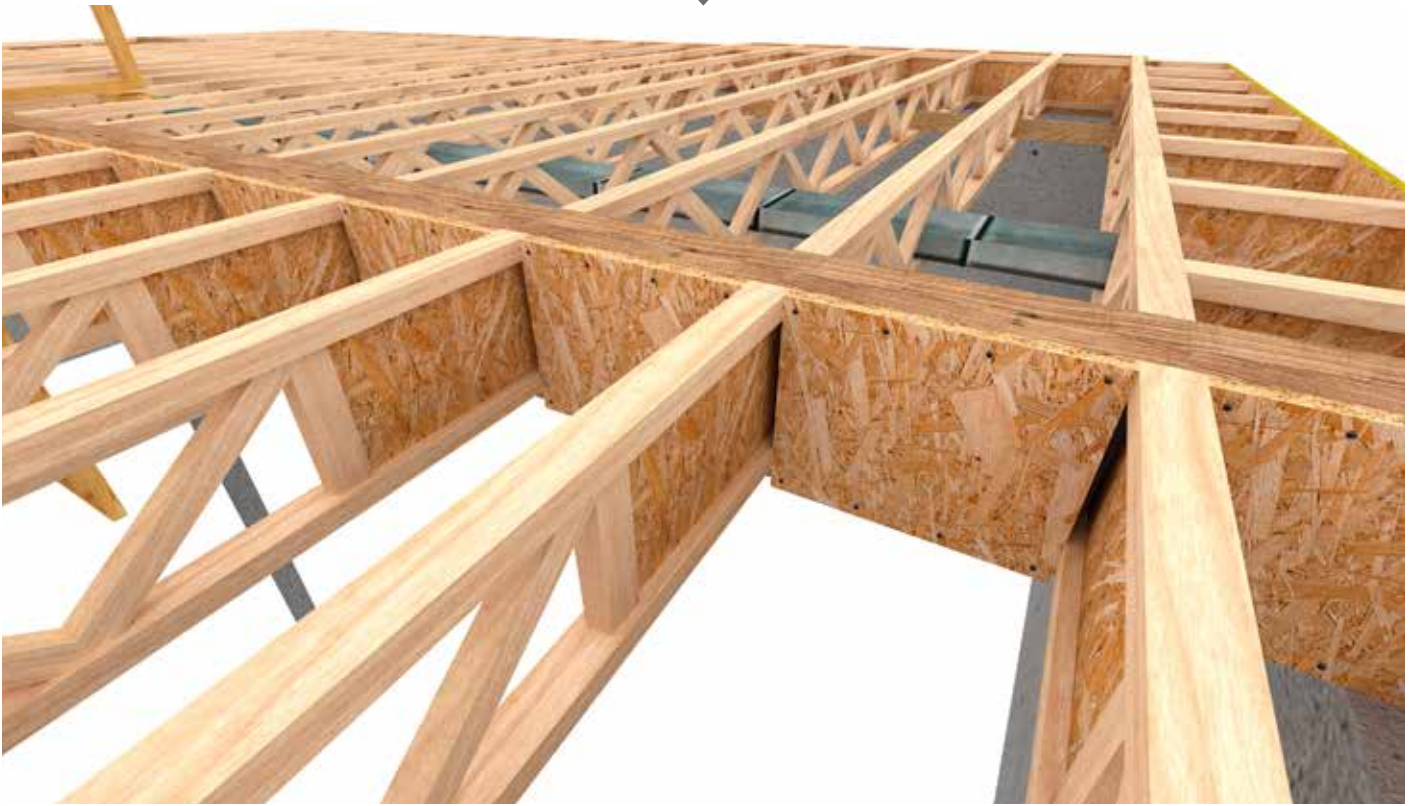

Multiple Joist Connectors (MJC) For Concentrated Side Load

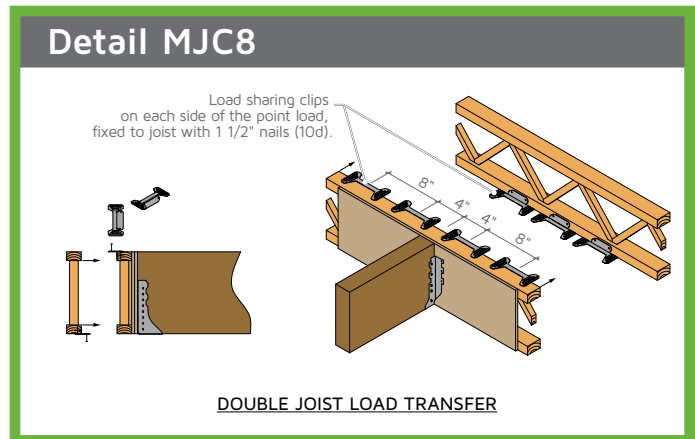
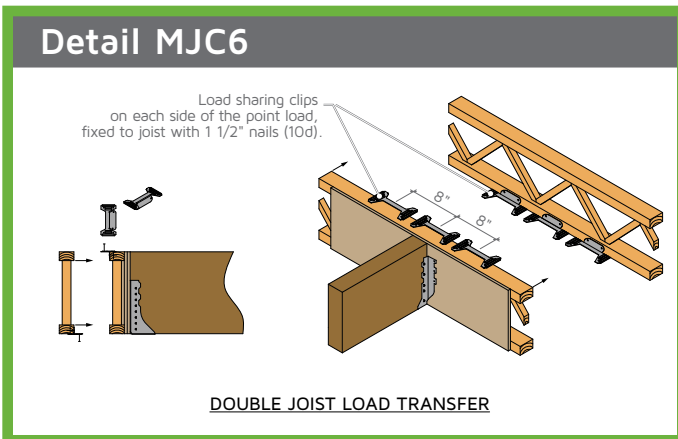
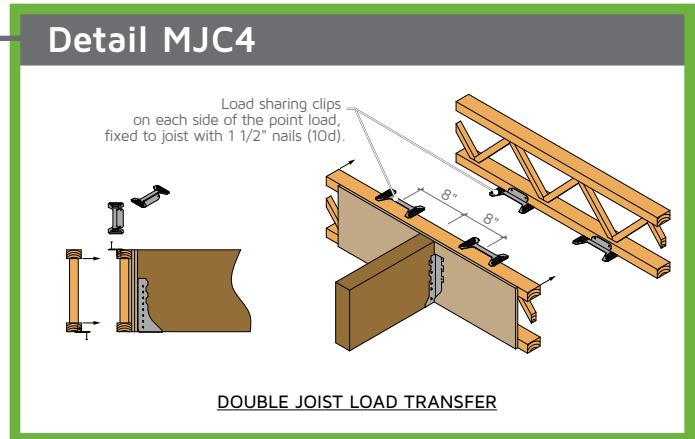
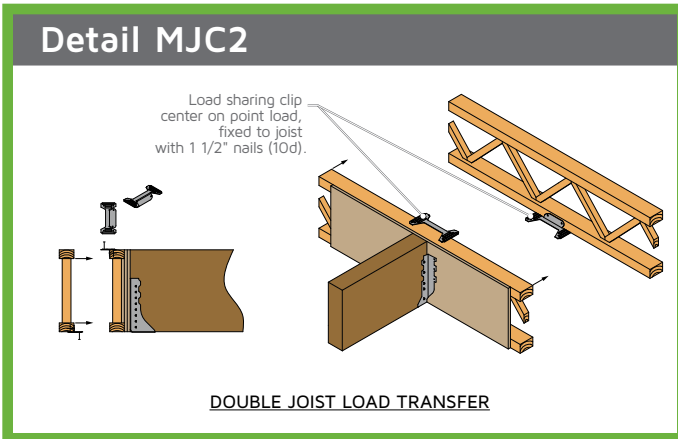

Reinforcement for Concentrated Side Load

Detail N10V11P

Filler 24" of length, center on, 1/2" Plywood or OSB, to the diagonals or OSB panel with adhesives and 2" nails at 3" o.c.

-for 2x3 Joist: 1 ply if fixed to the diagonals or 2 plies if fixed to OSB end panel,
-for 2x4 Joist: 2 plies if fixed to the diagonals or 3 plies if fixed to si OSB end panel,

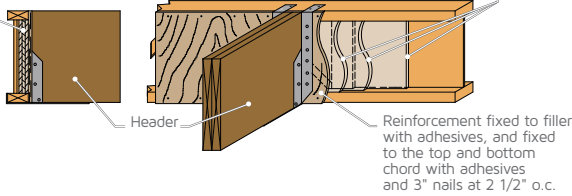

**ONE SIDE REINFORCEMENT
SINGLE JOIST**

Detail N10V12P

Filler 24" of length, center on, 1/2" Plywood or OSB, to the diagonals or OSB panel with adhesives and 2" nails at 3" o.c.

-for 2x3 Joist: 1 ply if fixed to the diagonals or 2 plies if fixed to OSB end panel,
-for 2x4 Joist: 2 plies if fixed to the diagonals or 3 plies if fixed to si OSB end panel,

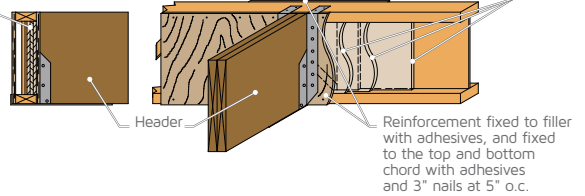

**TWO SIDES REINFORCEMENT
SINGLE JOIST**

Detail N10V21P

Filler 24" of length, center on, 1/2" Plywood or OSB, to the diagonals or OSB panel with adhesives and 2" nails at 3" o.c.

-for 2x3 Joist: 1 ply if fixed to the diagonals or 2 plies if fixed to OSB end panel,
-for 2x4 Joist: 2 plies if fixed to the diagonals or 3 plies if fixed to si OSB end panel,

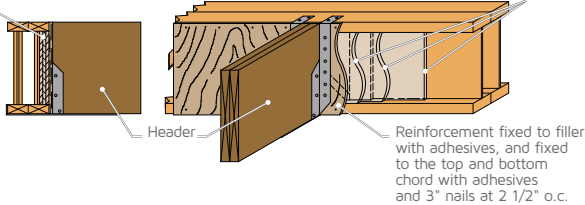

**ONE SIDE REINFORCEMENT
DOUBLE JOISTS**

Detail N10V22P

Filler 24" of length, center on, 1/2" Plywood or OSB, to the diagonals or OSB panel with adhesives and 2" nails at 3" o.c.

-for 2x3 Joist: 1 ply if fixed to the diagonals or 2 plies if fixed to OSB end panel,
-for 2x4 Joist: 2 plies if fixed to the diagonals or 3 plies if fixed to si OSB end panel,

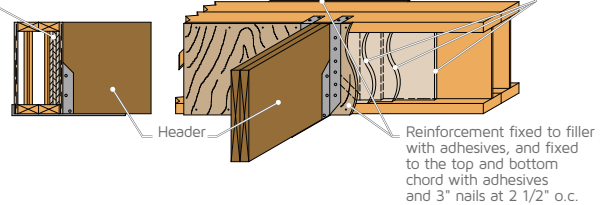

**TWO SIDES REINFORCEMENT
DOUBLE JOISTS**



Reinforcement for Concentrated Top Load

Detail N11VS4

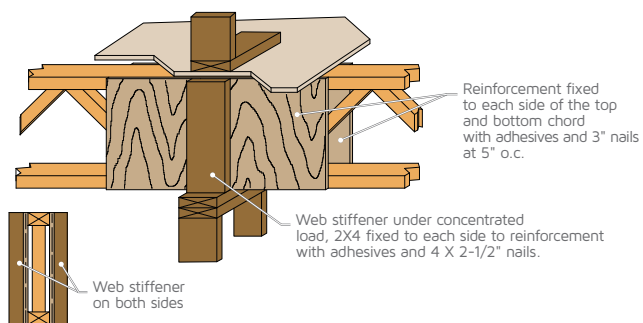

Detail N11V

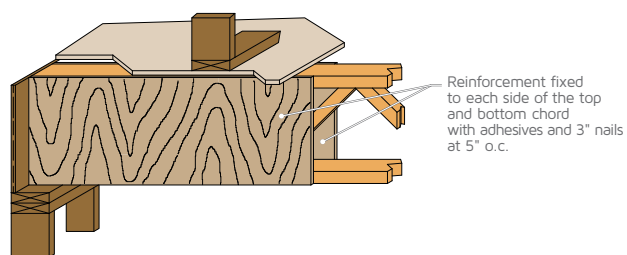

Detail N11VS

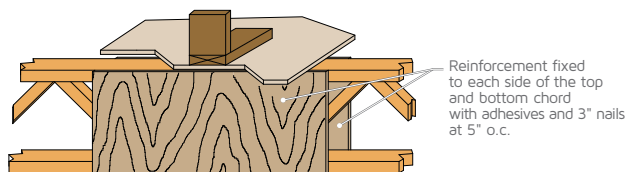

Allowable OSB Panel End Hole Penetrations

Holes sizes and locations - Simple span

Joist Depth	Joist Series	Round hole diameter only (in)											Max Span	
		Minimum distance from inside face of support to beginning of hole (ft-in)												
		2"	3"	4"	5"	6"	7"	8"	9"	10"	11"	12"		
9.5"	OJ314	0' 5"	0' 5"	0' 5"	1' 6"									16' 0"
	OJ418	0' 5"	0' 6"	2' 0"										20' 0"
11.875"	OJ314	0' 6"	0' 6"	0' 6"	0' 6"	0' 6"	1' 2"							16' 0"
	OJ315	0' 6"	0' 6"	0' 6"	0' 6"	1' 0"	2' 0"							18' 0"
	OJ415	0' 6"	0' 6"	0' 6"	1' 0"	2' 0"								20' 0"
	OJ418	0' 6"	0' 6"	1' 0"	2' 0"									22' 0"
14"	OJ314	0' 6"	0' 6"	0' 6"	0' 6"	0' 6"	0' 6"	0' 6"	0' 9"	1' 10"				16' 0"
	OJ315	0' 6"	0' 6"	0' 6"	0' 6"	0' 6"	0' 6"	1' 6"						20' 0"
	OJ415	0' 6"	0' 6"	0' 6"	0' 6"	0' 6"	1' 6"	2' 0"						22' 0"
	OJ418	0' 6"	0' 6"	0' 9"	1' 6"	2' 2"								26' 0"
16"	OJ314	0' 6"	0' 6"	0' 6"	0' 6"	0' 6"	0' 6"	0' 6"	0' 6"	0' 9"	1' 6"			16' 0"
	OJ315	0' 6"	0' 6"	0' 6"	0' 6"	0' 6"	0' 6"	0' 6"	0' 6"	1' 0"	1' 8"			20' 0"
	OJ318	0' 6"	0' 6"	0' 6"	0' 6"	0' 6"	0' 6"	0' 6"	0' 6"	1' 0"	1' 8"			18' 0"
	OJ418	0' 6"	0' 6"	0' 6"	0' 6"	0' 6"	1' 0"	2' 0"						26' 0"
	OJ420	0' 6"	0' 6"	0' 9"	1' 6"	2' 0"								30' 0"

Notes

- 1) This table is based on uniformly loaded floor with a design live load of 40 psf dead load of 15 psf and a deflection limit of L/360. For other applications contact your TRIFORCE® representative.
- 2) This table may be used for floor joist spacing of 24 inches on center or less.
- 3) Residential design with simple span only. No cantilever
- 4) Do not cut first vertical web. Distance base on a full length panel



Contact your TRIFORCE® representative for more details.

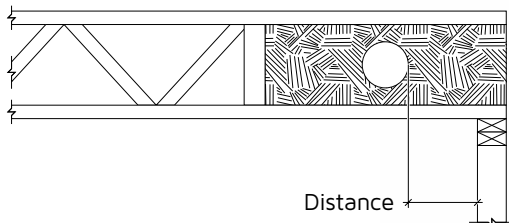

Mechanical Clearances

Depth	Mechanical Opening Dimension		
	Round	Square	Rectangular
9½"	5"	4" x 6"	3" x 9"
11½"	7¼"	5¾" x 5¾"	3" x 13"
14"	8½"	6½" x 6½"	3" x 14", 6" x 8"
16"	9½"	7½" x 7½"	3" x 15"



Strongbacks

Strongbacks contribute to floor system performance but are optional.

Strongbacks must be of dry lumber and secured with 2 spiral or resined 3" nails or 2 - 3" screws at mid-span, to a vertical brace or diagonal web.

Strongback can be cut between 2 joists for ducts, pipes and wires if needed, but at least 3 consecutive joists must remain attached together.

9 1/2" = 2x4

11 7/8" = 2x4

14" = 2x4 or 2x6

16" = 2x6 or 2x8



Detail N5

Strongback (at mid span)

Option #1 (Good)

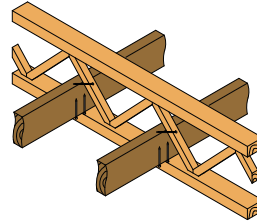

2x3 flanges: 1 - 3" (10d) through bottom flange and 1 - 3" (10d) through the diagonal, adding adhesive will insure long term performance

2x4 flanges: 2 - 3" (10d) through bottom flange and 1 - 3" (10d) through the diagonal.

Adding adhesive will ensure long term performance. Gun nails can be substituted with 3" screws.

Option #2 (Better)

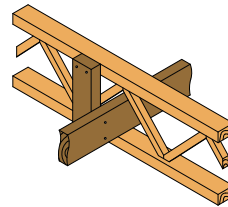

Secure vertical side block (2x4) as per detail, with 2 nails* to both chords and strongback to vertical with 2 nails*. *(gun nails 0.122" x 3 1/4")

Adding adhesive will provide an ultimate connection for high floor performance. Gun nails can be substituted with 3" screws.

Strongback Overlap

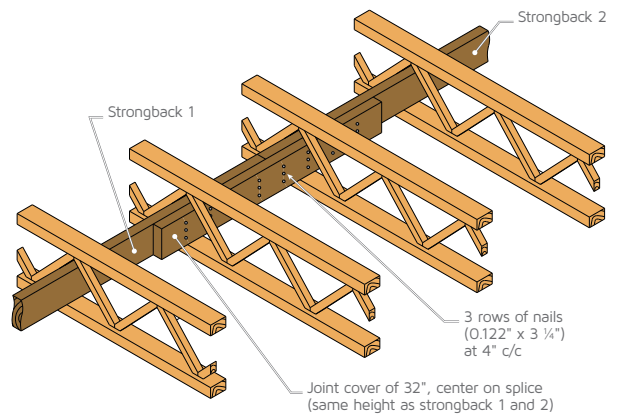

TRIFORCE® Floor Performance

For more than a decade the **National Building Code** of Canada has introduced a method of calculation which takes into account the performance of a floor as a whole, i.e., the ability of the Assembly to reduce vibrations and deflection induced by any movement.

Essentially, we feel both when someone moves on a floor where we are sitting, deformation is induced by the weight of this person and vibration due to the shock wave imposed by the movement of this person.

For several years the engineered wood industry has advocated a deflection criteria of L/480, more severe than the minimum standard of the National Building Code, however, this approach was assessing only one part of the performance of the floor, deflection.

The Calculation method advocated by the CNBC takes account of two factors that can influence the performance of floor, making it much more efficient. For these reasons, since the beginning of the 2000s, the method of calculation is mandatory and replace the standard of L/480 in Canada.

To comply with these requirements the vibration test is an integral part of our design software and can assess the performance of several floor assemblies. This option is also available in our US version of the software to help providing the best floor solution to end-users.

The advantage of the concept of open web joists...

One of the ways to effectively increase the performance of a floor, is to increase transversal rigidity, that is, to link perpendicular joists. Much of this transversal link is through the subfloor.

With the concept of the open web joist, the addition of a continuous strongback in solid wood contributes to the effective link which will have a major impact on the performance of the floor. In addition, the ease with which these continuous strongback can be installed and especially the effectiveness of nailing make its installation a good option for floor performance.

Other methods can be used to ensure good performance of your floor, for example;

- The use of a subfloor **nailed and glued** will have a beneficial effect providing a link more effective between joists and subfloor while eliminating the risk of noise due to a poorly nailed subfloor.
- The use of a thicker subfloor will also help increase the performance of your floor by increasing the distribution of loads more between the joists.
- Reducing Spacing or increase the height of the joists would also increase floor performance.

Why the Industry still uses the L/480 concept?

Normally this notion should have been replaced by the concept of the Assembly floor, it is wrong to claim that only reducing joists deflection prevents vibration problems.

Assembly approach is much more efficient, the last ten years have shown.

Due to the complexity of the method of calculation and the wide range of possibility of assemblages, some manufacturers have been slow to update with this concept.

How can I get an idea of the property of these additions

Here are a few examples:

Assembly floor base

- Subfloor 5/8" only nailed
- Height 11 7/8"

Allowable span: 14' 5"

Use of a subfloor glued and nailed,

Allowable span: 15' 9"

Use of a continuous link and a subfloor nailed and glued, Allowable span: 17' 2"

Keeping in mind that a factor of 0.5 assumes a greater floor performance than 0.99.

With a span of 14' 5", the floor performance ratio is 0.99, with the same span adding a glued subfloor, this ratio drops to 0.76, and if a continuous strongback is added, this ratio, is now 0.60, a 40% increase in floor performance.

Fire Performance

Since 1990, a lot of work has been done on fire rated floor and wall assemblies in Canada through the National Research Council and in US. Most Engineered product manufacturers team up to help providing guidelines but moreover typical floor assemblies to end users like architects and builders. This large scale effort conducted by NRC, lead to the many publications of floor assemblies including engineered wood products in section A-9.10.3.1.B of the National Building Code.

In this section more than 300 assemblies for engineered products are listed with acoustical performance rating (STC/IIC) and most of them are fire rated.

In US, the American wood council has also published a document entitled «Design for Code Acceptance – Fire rated wood frame wall and floor/ceiling assemblies» which also provides generic details for engineering wood products.

Open Joist TRIFORCE® Fire Performance Rating?

Historically, the OpenJoist and the TRIFORCE® products have outperformed other types of engineered wood products like I-Joist or Floor Trusses using metal connectors. OpenJoist has, in its web material, a larger thermal mass that dictates a longer time to increase in temperature and therefore enhance its fire resistance; this thermal mass increase is even more significant when strongbacks are in place.

Moreover the open configuration will increase the lateral heat transfer and allows increased thermal transmission evenly throughout the void spreading out the elevated temperature and again enhancing the fire performance of the structure.

1. TRIFORCE®
2. Strongbacks
3. Resilient Channels
4. Gypsum Board
5. Insulation
6. Sub-Floor



Again today with the introduction of the new generation of OpenJoist products – TRIFORCE®, our product has demonstrated outstanding fire performance. Both OpenJoist products carry a 1 hour rating with 1 layer of 5/8 gypsum board Type C for all flange sizes and depths. We are one of the few that still provide this 1 hour fire rated assembly in its simplest form which greatly expedites its field installation.

Based on its outstanding fire performance, the open joist TRIFORCE® product can be used in any of the listed assemblies of the National Building code providing equivalent fire resistance.

- Fire rated Assembly – 1 hour with 1 layer of 5/8 type C
- Fire rated Assembly – 1 hour with 2 layers of 1/2 type C
- Fire rated Assembly – 45 minutes 1 layer of 5/8 type X

1-Hour Fire Resistance Rated Floor Assembly

Floor/Ceiling – 100% Design Load – 1 Hour Rating – 1 Layer Gypsum

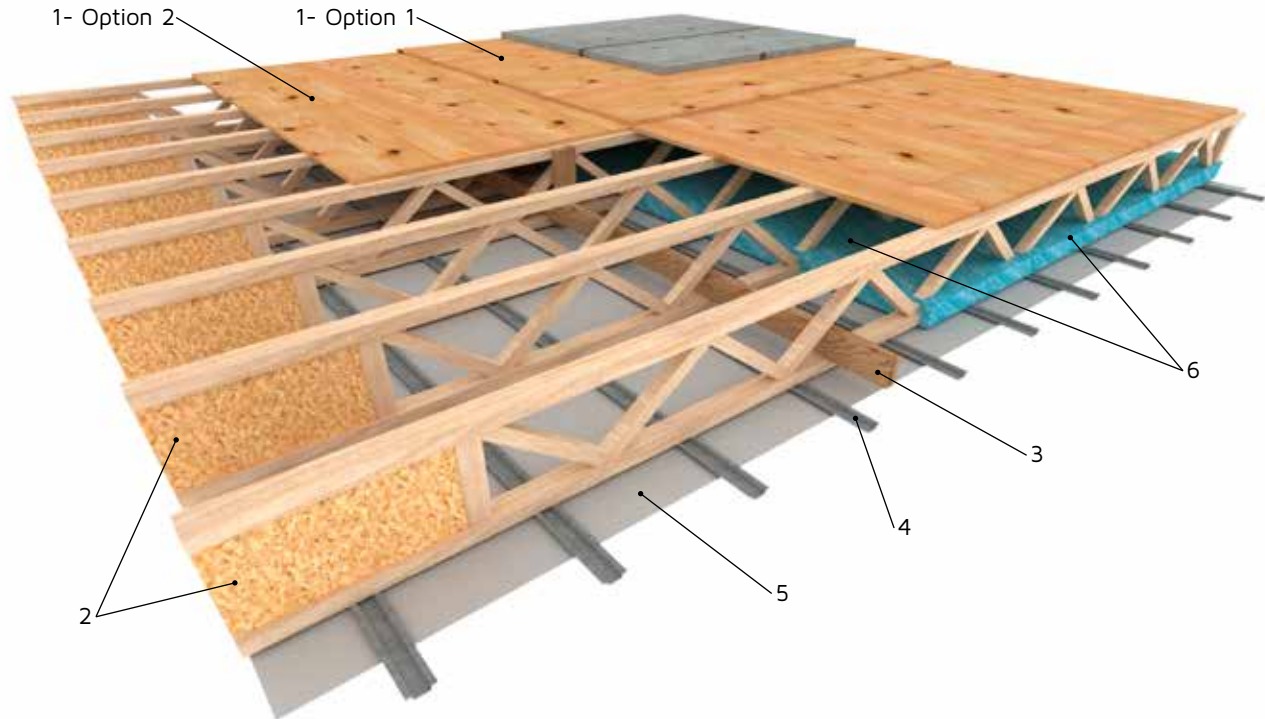

1- Sub floor :

Option 1: Install two layers of nominal 23/32-inch thick tongue and groove plywood subfloor sheathing. Apply a nominal 1/8-inch bead of adhesive meeting the following requirements: ASTM D 3498 Standard Specification for Adhesives for Field Gluing Plywood to Lumber Framing for Floor Systems, meets American Plywood Association specifications AFG-01. Apply the base layer of sheathing to the top side of the wood truss (item 2) and secure using 2-inch long X 0.113-inch diameter smooth shank nails perimeter and 12-inches on center in field. Install the face layer of sheathing over the base layer with a 24-inch overlap of joints.

Secure face layer using 3-inch long, 0.12-inch diameter smooth shank nails spaced 6-inches on center around the perimeter and 12-inches on center in the field.

Option 2: Install one layer of nominal 23/32-inch thick tongue and groove plywood subfloor sheathing. Apply a nominal 1/8-inch bead of adhesive meeting the following requirements: ASTM D 3498 Standard Specification for Adhesives for Field Gluing Plywood to Lumber Framing for Floor Systems, meets American Plywood Association specifications AFG-01. Apply the sheathing to the top side of the wood truss (Item 2) and secure using 2-inch long X 0.113-inch diameter smooth

shank nails spaced 6-inches on center in the field. Minimum topping thickness for lightweight concrete or nominal weight concrete is 1-1/2-inches. Minimum topping thickness for proprietary gypsum/cement/sand topping is 3/4-inch.

2- Structural members :

Use a minimum 9-1/2-inch open joist **TRIFORCE**® Joist spaced at a maximum of 24-inches on-center. Fasten wood truss to rim board with 2-3/8-inch long, 8d common nails. Fasten 1 nail through the rim board into the end of each flange, and one on each side of the truss web into the bearing plate.

3- Support :

Install strongback consisting of 2x6 and 2x4 lumber. Install strongback through the closest bottom open truss to the center on the wood truss (Item 2). Secure 2x4 lumber to the wood truss (Item 2) using 3-1/4-inch long, 12d common nails and adhesive. Secure the strongback to each wood truss (Item 2) using 2-1/4-inch long, 12d common nails and adhesive meeting the specifications above.

4- Resilient channels :

Install 1/2-inch deep, 2-1/8-inch wide nominal 25 GA galvanized steel "hat shaped" (RC-2) channels spaced 16-inches on-center and applied perpendicular to the Wood Truss, ensuring channels are installed back-to-back at butt joints of the gypsum board (Item 5). Secure resilient channels to the bottom flange of each Wood Truss (Item 2) using number 6, 1-5/8-inch long Type W coarse thread drywall screws.

5- Gypsum Board :

Install 1 layers of 5/8" of Gypsum Board Type C. Long edges located between joists perpendicular to the resilient channels (Item 4) using number 6-inches, 1-1/4-inch long Type S screws spaced 6-inches on center with a minimum distance of 1-1/2-inches from the panel edges. Joints are taped and finished with 2 layers of compound.

6- Insulation :

Install nominal 3-inch thick Roxul Safe'n Sound mineral wool insulation press fit between the bottom flanges of the wood truss (Item 2).

Reference: Intertek report DTM/FWT 60-10 for a 1-hr Fire Resistance rated floor assembly

Sound Performance

Acoustical Performance

Even if Open Joist published its own acoustical performance rating, once again, the listed assemblies of section A-9.10.3.1.B starting at assembly F22 can be used in your project. Moreover, as part of the NCR effort a software has been design and available on NRC website can help you out in finding the proper performance for your need.

<http://www.nrc-cnrc.gc.ca/eng/ibp/irc/software.html>

STC and IIC Defined

Since late 90's, building codes have stringent requirements of acoustical performance, two main components of acoustical analysis are set as guidelines for assess noise generate in a building.

These two methodologies are Impact Insulation Class (IIC) and a Sound Transmission Class (STC)

Impact Insulation Class – the impact insulation class would be a rating in Decibel on how well a floor attenuates impact sounds, such as footstep

Sound Transmission Class – the sound transmission class would rate in decibel how well a floor or a partition wall would attenuate airborne sound, such as music.

For both cases higher figures are better results

Floor/Ceiling Assembly Ratings for Multi-family building

How do we increase acoustical performance?

As mentioned above, a lot of efforts were put toward acoustical performance, mostly for multifamily complex and high end condominium where sound transmission takes all its meaning. After decades of testing NRC has developed tables to help architects and builders in finding the proper floor assembly.

Like, fire performance, acoustic performance will be dictated by the floor assembly, based on the NRC tables published in the NBCC in annex A-9.10.3.1.B and proprietary testing on OJ2000 and open joist **TRIFORCE®**, we have tried to clearly express how to increase the acoustical performance of a floor.

QuickTools Software

Barrette Structural has created an easy to use, sophisticated, state of the art software solution designed to suit all of our customer's needs, focusing on user friendliness, detailed engineering analysis, quotes, orders and layouts.

Our solutions will help your company on every level, from whole floor analysis to individual member sizing.

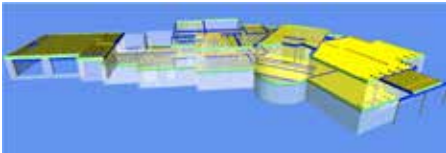

QuickTools Layout Assistant is a fully integrated 3D software solution that easily provides a robust layout and open joist **TRIFORCE**® design solution as well as the full engineering analysis required by major building codes throughout North America and Europe. Quickly draw Walls, Beams, Columns, Openings, Headers and open joist **TRIFORCE**® and Quickly analyze the load transfer. QuickTools Layout Assistant is available for download and can be obtained from an open joist **TRIFORCE**® Representative via download.

QuickTools Analyzer Assistant is a single member sizing software that enables Engineers, Architects and Designers to size the open joist **TRIFORCE**® floor joists. QuickTools Analyzer Assistant is available as a stand alone software for download and can be obtained from an open joist **TRIFORCE**® Representative via download.

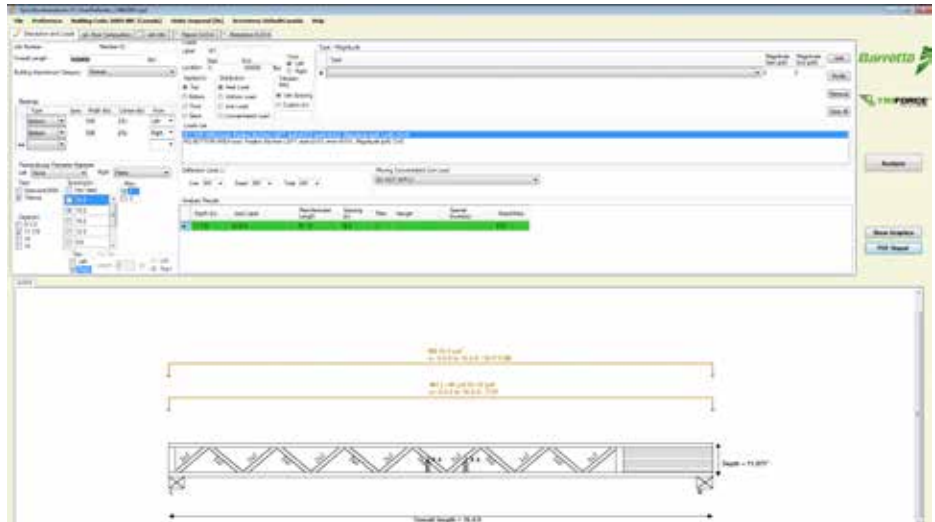
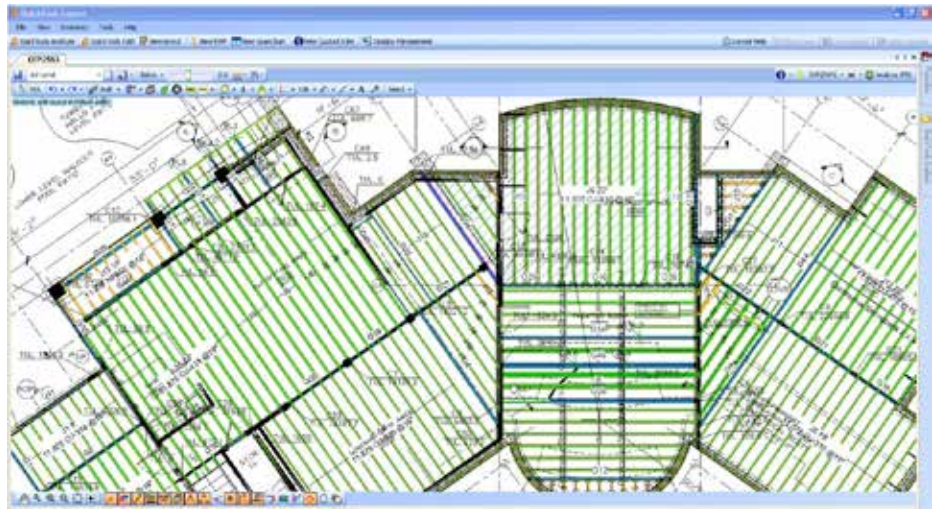

Hardware Requirements

- Multi-Core Intel Xeon, or i-Series processor or AMD equivalent with SSE2 technology
- 2GB Ram (Min)
- Windows 7, Vista or XP Professional
- DirectX® 10 capable graphics card
- 2 GB free disk space
- MS-Mouse or 3Dconnexion compliant device
- Internet connection for license registration and prerequisite component download.

TRIFORCE		Manufacturer or Distributor		Barrette Structural, CH2000, etc.	
Product name		Drawing by		Job number	
Left: 0.000", right: 0.000"		Customer		Building address	
Left: None, right: None		Project		0214 (3 X 2, 11' 7 7/8", 16'-0", 1 ply, 19'30" o.c.)	
BEARING ANALYSIS			LOAD CASES		
Unit	Unit	Unit	Unit	Unit	Unit
Load	Wash Coat	P ₁	K ₁	R ₁	Critical
1	SS-8	SS-12	SS-18	SS-24	SS-30
2	SS-8	SS-12	SS-18	SS-24	SS-30
CHORD CONCENTRATED LOAD ANALYSIS (No environmental request)					
Unit	Unit	Unit	Unit	Unit	Unit
Load	Wash Coat	P ₁	K ₁	R ₁	Critical
1	SS-8	SS-12	SS-18	SS-24	SS-30
DECK ANALYSIS (No environmental request)					
Unit	Unit	Unit	Unit	Unit	Unit
Load	Wash Coat	P ₁	K ₁	R ₁	Critical
1	SS-8	SS-12	SS-18	SS-24	SS-30
LOADING (No environmental request)					
Unit	Unit	Unit	Unit	Unit	Unit
Load	Wash Coat	P ₁	K ₁	R ₁	Critical
1	SS-8	SS-12	SS-18	SS-24	SS-30
REINFORCEMENT CATEGORY Normal, L ₁ , L ₂ , L ₃ , L ₄ , L ₅ , L ₆ , L ₇ , L ₈ , L ₉ , L ₁₀ , L ₁₁ , L ₁₂ , L ₁₃ , L ₁₄ , L ₁₅ , L ₁₆ , L ₁₇ , L ₁₈ , L ₁₉ , L ₂₀ , L ₂₁ , L ₂₂ , L ₂₃ , L ₂₄ , L ₂₅ , L ₂₆ , L ₂₇ , L ₂₈ , L ₂₉ , L ₃₀ , L ₃₁ , L ₃₂ , L ₃₃ , L ₃₄ , L ₃₅ , L ₃₆ , L ₃₇ , L ₃₈ , L ₃₉ , L ₄₀ , L ₄₁ , L ₄₂ , L ₄₃ , L ₄₄ , L ₄₅ , L ₄₆ , L ₄₇ , L ₄₈ , L ₄₉ , L ₅₀ , L ₅₁ , L ₅₂ , L ₅₃ , L ₅₄ , L ₅₅ , L ₅₆ , L ₅₇ , L ₅₈ , L ₅₉ , L ₆₀ , L ₆₁ , L ₆₂ , L ₆₃ , L ₆₄ , L ₆₅ , L ₆₆ , L ₆₇ , L ₆₈ , L ₆₉ , L ₇₀ , L ₇₁ , L ₇₂ , L ₇₃ , L ₇₄ , L ₇₅ , L ₇₆ , L ₇₇ , L ₇₈ , L ₇₉ , L ₈₀ , L ₈₁ , L ₈₂ , L ₈₃ , L ₈₄ , L ₈₅ , L ₈₆ , L ₈₇ , L ₈₈ , L ₈₉ , L ₉₀ , L ₉₁ , L ₉₂ , L ₉₃ , L ₉₄ , L ₉₅ , L ₉₆ , L ₉₇ , L ₉₈ , L ₉₉ , L ₁₀₀ , L ₁₀₁ , L ₁₀₂ , L ₁₀₃ , L ₁₀₄ , L ₁₀₅ , L ₁₀₆ , L ₁₀₇ , L ₁₀₈ , L ₁₀₉ , L ₁₁₀ , L ₁₁₁ , L ₁₁₂ , L ₁₁₃ , L ₁₁₄ , L ₁₁₅ , L ₁₁₆ , L ₁₁₇ , L ₁₁₈ , L ₁₁₉ , L ₁₂₀ , L ₁₂₁ , L ₁₂₂ , L ₁₂₃ , L ₁₂₄ , L ₁₂₅ , L ₁₂₆ , L ₁₂₇ , L ₁₂₈ , L ₁₂₉ , L ₁₃₀ , L ₁₃₁ , L ₁₃₂ , L ₁₃₃ , L ₁₃₄ , L ₁₃₅ , L ₁₃₆ , L ₁₃₇ , L ₁₃₈ , L ₁₃₉ , L ₁₄₀ , L ₁₄₁ , L ₁₄₂ , L ₁₄₃ , L ₁₄₄ , L ₁₄₅ , L ₁₄₆ , L ₁₄₇ , L ₁₄₈ , L ₁₄₉ , L ₁₅₀ , L ₁₅₁ , L ₁₅₂ , L ₁₅₃ , L ₁₅₄ , L ₁₅₅ , L ₁₅₆ , L ₁₅₇ , L ₁₅₈ , L ₁₅₉ , L ₁₆₀ , L ₁₆₁ , L ₁₆₂ , L ₁₆₃ , L ₁₆₄ , L ₁₆₅ , L ₁₆₆ , L ₁₆₇ , L ₁₆₈ , L ₁₆₉ , L ₁₇₀ , L ₁₇₁ , L ₁₇₂ , L ₁₇₃ , L ₁₇₄ , L ₁₇₅ , L ₁₇₆ , L ₁₇₇ , L ₁₇₈ , L ₁₇₉ , L ₁₈₀ , L ₁₈₁ , L ₁₈₂ , L ₁₈₃ , L ₁₈₄ , L ₁₈₅ , L ₁₈₆ , L ₁₈₇ , L ₁₈₈ , L ₁₈₉ , L ₁₉₀ , L ₁₉₁ , L ₁₉₂ , L ₁₉₃ , L ₁₉₄ , L ₁₉₅ , L ₁₉₆ , L ₁₉₇ , L ₁₉₈ , L ₁₉₉ , L ₂₀₀ , L ₂₀₁ , L ₂₀₂ , L ₂₀₃ , L ₂₀₄ , L ₂₀₅ , L ₂₀₆ , L ₂₀₇ , L ₂₀₈ , L ₂₀₉ , L ₂₁₀ , L ₂₁₁ , L ₂₁₂ , L ₂₁₃ , L ₂₁₄ , L ₂₁₅ , L ₂₁₆ , L ₂₁₇ , L ₂₁₈ , L ₂₁₉ , L ₂₂₀ , L ₂₂₁ , L ₂₂₂ , L ₂₂₃ , L ₂₂₄ , L ₂₂₅ , L ₂₂₆ , L ₂₂₇ , L ₂₂₈ , L ₂₂₉ , L ₂₃₀ , L ₂₃₁ , L ₂₃₂ , L ₂₃₃ , L ₂₃₄ , L ₂₃₅ , L ₂₃₆ , L ₂₃₇ , L ₂₃₈ , L ₂₃₉ , L ₂₄₀ , L ₂₄₁ , L ₂₄₂ , L ₂₄₃ , L ₂₄₄ , L ₂₄₅ , L ₂₄₆ , L ₂₄₇ , L ₂₄₈ , L ₂₄₉ , L ₂₅₀ , L ₂₅₁ , L ₂₅₂ , L ₂₅₃ , L ₂₅₄ , L ₂₅₅ , L ₂₅₆ , L ₂₅₇ , L ₂₅₈ , L ₂₅₉ , L ₂₆₀ , L ₂₆₁ , L ₂₆₂ , L ₂₆₃ , L ₂₆₄ , L ₂₆₅ , L ₂₆₆ , L ₂₆₇ , L ₂₆₈ , L ₂₆₉ , L ₂₇₀ , L ₂₇₁ , L ₂₇₂ , L ₂₇₃ , L ₂₇₄ , L ₂₇₅ , L ₂₇₆ , L ₂₇₇ , L ₂₇₈ , L ₂₇₉ , L ₂₈₀ , L ₂₈₁ , L ₂₈₂ , L ₂₈₃ , L ₂₈₄ , L ₂₈₅ , L ₂₈₆ , L ₂₈₇ , L ₂₈₈ , L ₂₈₉ , L ₂₉₀ , L ₂₉₁ , L ₂₉₂ , L ₂₉₃ , L ₂₉₄ , L ₂₉₅ , L ₂₉₆ , L ₂₉₇ , L ₂₉₈ , L ₂₉₉ , L ₃₀₀ , L ₃₀₁ , L ₃₀₂ , L ₃₀₃ , L ₃₀₄ , L ₃₀₅ , L ₃₀₆ , L ₃₀₇ , L ₃₀₈ , L ₃₀₉ , L ₃₁₀ , L ₃₁₁ , L ₃₁₂ , L ₃₁₃ , L ₃₁₄ , L ₃₁₅ , L ₃₁₆ , L ₃₁₇ , L ₃₁₈ , L ₃₁₉ , L ₃₂₀ , L ₃₂₁ , L ₃₂₂ , L ₃₂₃ , L ₃₂₄ , L ₃₂₅ , L ₃₂₆ , L ₃₂₇ , L ₃₂₈ , L ₃₂₉ , L ₃₃₀ , L ₃₃₁ , L ₃₃₂ , L ₃₃₃ , L ₃₃₄ , L ₃₃₅ , L ₃₃₆ , L ₃₃₇ , L ₃₃₈ , L ₃₃₉ , L ₃₄₀ , L ₃₄₁ , L ₃₄₂ , L ₃₄₃ , L ₃₄₄ , L ₃₄₅ , L ₃₄₆ , L ₃₄₇ , L ₃₄₈ , L ₃₄₉ , L ₃₅₀ , L ₃₅₁ , L ₃₅₂ , L ₃₅₃ , L ₃₅₄ , L ₃₅₅ , L ₃₅₆ , L ₃₅₇ , L ₃₅₈ , L ₃₅₉ , L ₃₆₀ , L ₃₆₁ , L ₃₆₂ , L ₃₆₃ , L ₃₆₄ , L ₃₆₅ , L ₃₆₆ , L ₃₆₇ , L ₃₆₈ , L ₃₆₉ , L ₃₇₀ , L ₃₇₁ , L ₃₇₂ , L ₃₇₃ , L ₃₇₄ , L ₃₇₅ , L ₃₇₆ , L ₃₇₇ , L ₃₇₈ , L ₃₇₉ , L ₃₈₀ , L ₃₈₁ , L ₃₈₂ , L ₃₈₃ , L ₃₈₄ , L ₃₈₅ , L ₃₈₆ , L ₃₈₇ , L ₃₈₈ , L ₃₈₉ , L ₃₉₀ , L ₃₉₁ , L ₃₉₂ , L ₃₉₃ , L ₃₉₄ , L ₃₉₅ , L ₃₉₆ , L ₃₉₇ , L ₃₉₈ , L ₃₉₉ , L ₄₀₀ , L ₄₀₁ , L ₄₀₂ , L ₄₀₃ , L ₄₀₄ , L ₄₀₅ , L ₄₀₆ , L ₄₀₇ , L ₄₀₈ , L ₄₀₉ , L ₄₁₀ , L ₄₁₁ , L ₄₁₂ , L ₄₁₃ , L ₄₁₄ , L ₄₁₅ , L ₄₁₆ , L ₄₁₇ , L ₄₁₈ , L ₄₁₉ , L ₄₂₀ , L ₄₂₁ , L ₄₂₂ , L ₄₂₃ , L ₄₂₄ , L ₄₂₅ , L ₄₂₆ , L ₄₂₇ , L ₄₂₈ , L ₄₂₉ , L ₄₃₀ , L ₄₃₁ , L ₄₃₂ , L ₄₃₃ , L ₄₃₄ , L ₄₃₅ , L ₄₃₆ , L ₄₃₇ , L ₄₃₈ , L ₄₃₉ , L ₄₄₀ , L ₄₄₁ , L ₄₄₂ , L ₄₄₃ , L ₄₄₄ , L ₄₄₅ , L ₄₄₆ , L ₄₄₇ , L ₄₄₈ , L ₄₄₉ , L ₄₅₀ , L ₄₅₁ , L ₄₅₂ , L ₄₅₃ , L ₄₅₄ , L ₄₅₅ , L ₄₅₆ , L ₄₅₇ , L ₄₅₈ , L ₄₅₉ , L ₄₆₀ , L ₄₆₁ , L ₄₆₂ , L ₄₆₃ , L ₄₆₄ , L ₄₆₅ , L ₄₆₆ , L ₄₆₇ , L ₄₆₈ , L ₄₆₉ , L ₄₇₀ , L ₄₇₁ , L ₄₇₂ , L ₄₇₃ , L ₄₇₄ , L ₄₇₅ , L ₄₇₆ , L ₄₇₇ , L ₄₇₈ , L ₄₇₉ , L ₄₈₀ , L ₄₈₁ , L ₄₈₂ , L ₄₈₃ , L ₄₈₄ , L ₄₈₅ , L ₄₈₆ , L ₄₈₇ , L ₄₈₈ , L ₄₈₉ , L ₄₉₀ , L ₄₉₁ , L ₄₉₂ , L ₄₉₃ , L ₄₉₄ , L ₄₉₅ , L ₄₉₆ , L ₄₉₇ , L ₄₉₈ , L ₄₉₉ , L ₅₀₀ , L ₅₀₁ , L ₅₀₂ , L ₅₀₃ , L ₅₀₄ , L ₅₀₅ , L ₅₀₆ , L ₅₀₇ , L ₅₀₈ , L ₅₀₉ , L ₅₁₀ , L ₅₁₁ , L ₅₁₂ , L ₅₁₃ , L ₅₁₄ , L ₅₁₅ , L ₅₁₆ , L ₅₁₇ , L ₅₁₈ , L ₅₁₉ , L ₅₂₀ , L ₅₂₁ , L ₅₂₂ , L ₅₂₃ , L ₅₂₄ , L ₅₂₅ , L ₅₂₆ , L ₅₂₇ , L ₅₂₈ , L ₅₂₉ , L ₅₃₀ , L ₅₃₁ , L ₅₃₂ , L ₅₃₃ , L ₅₃₄ , L ₅₃₅ , L ₅₃₆ , L ₅₃₇ , L ₅₃₈ , L ₅₃₉ , L ₅₄₀ , L ₅₄₁ , L ₅₄₂ , L ₅₄₃ , L ₅₄₄ , L ₅₄₅ , L ₅₄₆ , L ₅₄₇ , L ₅₄₈ , L ₅₄₉ , L ₅₅₀ , L ₅₅₁ , L ₅₅₂ , L ₅₅₃ , L ₅₅₄ , L ₅₅₅ , L ₅₅₆ , L ₅₅₇ , L ₅₅₈ , L ₅₅₉ , L ₅₆₀ , L ₅₆₁ , L ₅₆₂ , L ₅₆₃ , L ₅₆₄ , L ₅₆₅ , L ₅₆₆ , L ₅₆₇ , L ₅₆₈ , L ₅₆₉ , L ₅₇₀ , L ₅₇₁ , L ₅₇₂ , L ₅₇₃ , L ₅₇₄ , L ₅₇₅ , L ₅₇₆ , L ₅₇₇ , L ₅₇₈ , L ₅₇₉ , L ₅₈₀ , L ₅₈₁ , L ₅₈₂ , L ₅₈₃ , L ₅₈₄ , L ₅₈₅ , L ₅₈₆ , L ₅₈₇ , L ₅₈₈ , L ₅₈₉ , L ₅₉₀ , L ₅₉₁ , L ₅₉₂ , L ₅₉₃ , L ₅₉₄ , L ₅₉₅ , L ₅₉₆ , L ₅₉₇ , L ₅₉₈ , L ₅₉₉ , L ₆₀₀ , L ₆₀₁ , L ₆₀₂ , L ₆₀₃ , L ₆₀₄ , L ₆₀₅ , L ₆₀₆ , L ₆₀₇ , L ₆₀₈ , L ₆₀₉ , L ₆₁₀ , L ₆₁₁ , L ₆₁₂ , L ₆₁₃ , L ₆₁₄ , L ₆₁₅ , L ₆₁₆ , L ₆₁₇ , L ₆₁₈ , L ₆₁₉ , L ₆₂₀ , L ₆₂₁ , L ₆₂₂ , L ₆₂₃ , L ₆₂₄ , L ₆₂₅ , L ₆₂₆ , L ₆₂₇ , L ₆₂₈ , L ₆₂₉ , L ₆₃₀ , L ₆₃₁ , L ₆₃₂ , L ₆₃₃ , L ₆₃₄ , L ₆₃₅ , L ₆₃₆ , L ₆₃₇ , L ₆₃₈ , L ₆₃₉ , L ₆₄₀ , L ₆₄₁ , L ₆₄₂ , L ₆₄₃ , L ₆₄₄ , L ₆₄₅ , L ₆₄₆ , L ₆₄₇ , L ₆₄₈ , L ₆₄₉ , L ₆₅₀ , L ₆₅₁ , L ₆₅₂ , L ₆₅₃ , L ₆₅₄ , L ₆₅₅ , L ₆₅₆ , L ₆₅₇ , L ₆₅₈ , L ₆₅₉ , L ₆₆₀ , L ₆₆₁ , L ₆₆₂ , L ₆₆₃ , L ₆₆₄ , L ₆₆₅ , L ₆₆₆ , L ₆₆₇ , L ₆₆₈ , L ₆₆₉ , L ₆₇₀ , L ₆₇₁ , L ₆₇₂ , L ₆₇₃ , L ₆₇₄ , L ₆₇₅ , L ₆₇₆ , L ₆₇₇ , L ₆₇₈ , L ₆₇₉ , L ₆₈₀ , L ₆₈₁ , L ₆₈₂ , L ₆₈₃ , L ₆₈₄ , L ₆₈₅ , L ₆₈₆ , L ₆₈₇ , L ₆₈₈ , L ₆₈₉ , L ₆₉₀ , L ₆₉₁ , L ₆₉₂ , L ₆₉₃ , L ₆₉₄ , L ₆₉₅ , L ₆₉₆ , L ₆₉₇ , L ₆₉₈ , L ₆₉₉ , L ₇₀₀ , L ₇₀₁ , L ₇₀₂ , L ₇₀₃ , L ₇₀₄ , L ₇₀₅ , L ₇₀₆ , L ₇₀₇ , L ₇₀₈ , L ₇₀₉ , L ₇₁₀ , L ₇₁₁ , L ₇₁₂ , L ₇₁₃ , L ₇₁₄ , L ₇₁₅ , L ₇₁₆ , L ₇₁₇ , L ₇₁₈ , L ₇₁₉ , L ₇₂₀ , L ₇₂₁ , L ₇₂₂ , L ₇₂₃ , L ₇₂₄ , L ₇₂₅ , L ₇₂₆ , L ₇₂₇ , L ₇₂₈ , L ₇₂₉ , L ₇₃₀ , L ₇₃₁ , L ₇₃₂ , L ₇₃₃ , L ₇₃₄ , L ₇₃₅ , L ₇₃₆ , L ₇₃₇ , L ₇₃₈ , L ₇₃₉ , L ₇₄₀ , L ₇₄₁ , L ₇₄₂ , L ₇₄₃ , L ₇₄₄ , L ₇₄₅ , L ₇₄₆ , L ₇₄₇ , L ₇₄₈ , L ₇₄₉ , L ₇₅₀ , L ₇₅₁ , L ₇₅₂ , L ₇₅₃ , L ₇₅₄ , L ₇₅₅ , L ₇₅₆ , L ₇₅₇ , L ₇₅₈ , L ₇₅₉ , L ₇₆₀ , L ₇₆₁ , L ₇₆₂ , L ₇₆₃ , L ₇₆₄ , L ₇₆₅ , L ₇₆₆ , L ₇₆₇ , L ₇₆₈ , L ₇₆₉ , L ₇₇₀ , L ₇₇₁ , L ₇₇₂ , L ₇₇₃ , L ₇₇₄ , L ₇₇₅ , L ₇₇₆ , L ₇₇₇ , L ₇₇₈ , L ₇₇₉ , L ₇₈₀ , L ₇₈₁ , L ₇₈₂ , L ₇₈₃ , L ₇₈₄ , L ₇₈₅ , L ₇₈₆ , L ₇₈₇ , L ₇₈₈ , L ₇₈₉ , L ₇₉₀ , L ₇₉₁ , L ₇₉₂ , L ₇₉₃ , L ₇₉₄ , L ₇₉₅ , L ₇₉₆ , L ₇₉₇ , L ₇₉₈ , L ₇₉₉ , L ₈₀₀ , L ₈₀₁ , L ₈₀₂ , L ₈₀₃ , L ₈₀₄ , L ₈₀₅ , L ₈₀₆ , L ₈₀₇ , L ₈₀₈ , L ₈₀₉ , L ₈₁₀ , L ₈₁₁ , L ₈₁₂ , L ₈₁₃ , L ₈₁₄ , L ₈₁₅ , L ₈₁₆ , L ₈₁₇ , L ₈₁₈ , L ₈₁₉ , L ₈₂₀ , L ₈₂₁ , L ₈₂₂ , L ₈₂₃ , L ₈₂₄ , L ₈₂₅ , L ₈₂₆ , L ₈₂₇ , L ₈₂₈ , L ₈₂₉ , L ₈₃₀ , L ₈₃₁ , L ₈₃₂ , L ₈₃₃ , L ₈₃₄ , L ₈₃₅ , L ₈₃₆ , L ₈₃₇ , L ₈₃₈ , L ₈₃₉ , L ₈₄₀ , L ₈₄₁ , L ₈₄₂ , L ₈₄₃ , L ₈₄₄ , L ₈₄₅ , L ₈₄₆ , L ₈₄₇ , L ₈₄₈ , L ₈₄₉ , L ₈₅₀ , L ₈₅₁ , L ₈₅₂ , L ₈₅₃ , L ₈₅₄ , L ₈₅₅ , L ₈₅₆ , L ₈₅₇ , L ₈₅₈ , L ₈₅₉ , L ₈₆₀ , L ₈₆₁ , L ₈₆₂ , L ₈₆₃ , L ₈₆₄ , L ₈₆₅ , L ₈₆₆ , L ₈₆₇ , L ₈₆₈ , L ₈₆₉ , L ₈₇₀ , L ₈₇₁ , L ₈₇₂ , L ₈₇₃ , L ₈₇₄ , L ₈₇₅ , L ₈₇₆ , L ₈₇₇ , L ₈₇₈ , L ₈₇₉ , L ₈₈₀ , L ₈₈₁ , L ₈₈₂ , L ₈₈₃ , L ₈₈₄ , L ₈₈₅ , L ₈₈₆ , L ₈₈₇ , L ₈₈₈ , L ₈₈₉ , L ₈₉₀ , L ₈₉₁ , L ₈₉₂ , L ₈₉₃ , L ₈₉₄ , L ₈₉₅ , L ₈₉₆ , L ₈₉₇ , L ₈₉₈ , L ₈₉₉ , L ₉₀₀ , L ₉₀₁ , L ₉₀₂ , L ₉₀₃ , L ₉₀₄ , L ₉₀₅ , L ₉₀₆ , L ₉₀₇ , L ₉₀₈ , L ₉₀₉ , L ₉₁₀ , L ₉₁₁ , L ₉₁₂ , L ₉₁₃ , L ₉₁₄ , L ₉₁₅ , L ₉₁₆ , L ₉₁₇ , L ₉₁₈ , L ₉₁₉ , L ₉₂₀ , L ₉₂₁ , L ₉₂₂ , L ₉₂₃ , L ₉₂₄ , L ₉₂₅ , L ₉₂₆ , L ₉₂₇ , L ₉₂₈ , L ₉₂₉ , L ₉₃₀ , L ₉₃₁ , L ₉₃₂ , L ₉₃₃ , L ₉₃₄ , L ₉₃₅ , L ₉₃₆ , L ₉₃₇ , L ₉₃₈ , L ₉₃₉ , L ₉₄₀ , L ₉₄₁ , L ₉₄₂ , L ₉₄₃ , L ₉₄₄ , L ₉₄₅ , L ₉₄₆ , L ₉₄₇ , L ₉₄₈ , L ₉₄₉ , L ₉₅₀ , L ₉₅₁ , L ₉₅₂ , L ₉₅₃ , L ₉₅₄ , L ₉₅₅ , L ₉₅₆ , L ₉₅₇ , L ₉₅₈ , L ₉₅₉ , L ₉₆₀ , L ₉₆₁ , L ₉₆₂ , L ₉₆₃ , L ₉₆₄ , L ₉₆₅ , L ₉₆₆ , L ₉₆₇ , L ₉₆₈ , L ₉₆₉ , L ₉₇₀ , L ₉₇₁ , L ₉₇₂ , L ₉₇₃ , L ₉₇₄ , L ₉₇₅ , L ₉₇₆ , L ₉₇₇ , L ₉₇₈ , L ₉₇₉ , L ₉₈₀ , L ₉₈₁ , L ₉₈₂ , L ₉₈₃ , L ₉₈₄ , L ₉₈₅ , L ₉₈₆ , L ₉₈₇ , L ₉₈₈ , L ₉₈₉ , L ₉₉₀ , L ₉₉₁ , L ₉₉₂ , L ₉₉₃ , L ₉₉₄ , L ₉₉₅ , L ₉₉₆ , L ₉₉₇ , L ₉₉₈ , L ₉₉₉ , L ₁₀₀₀ , L ₁₀₀₁ , L ₁₀₀₂ , L ₁₀₀₃ , L ₁₀₀₄ , L ₁₀₀₅ , L ₁₀₀₆ , L ₁₀₀₇ , L ₁₀₀₈ , L ₁₀₀₉ , L ₁₀₁₀ , L ₁₀₁₁ , L ₁₀₁₂ , L ₁₀₁₃ , L ₁₀₁₄ , L ₁₀₁₅ , L ₁₀₁₆ , L ₁₀₁₇ , L ₁₀₁₈ , L ₁₀₁₉ , L ₁₀₂₀ , L ₁₀₂₁ , L ₁₀₂₂ , L ₁₀₂₃ , L ₁₀₂₄ , L ₁₀₂₅ , L ₁₀₂₆ , L ₁₀₂₇ , L ₁₀₂₈ , L ₁₀₂₉ , L ₁₀₃₀ , L ₁₀₃₁ , L ₁₀₃₂ , L ₁₀₃₃ , L ₁₀₃₄ , L ₁₀₃₅ , L ₁₀₃₆ , L ₁₀₃₇ , L ₁₀₃₈ , L					

Single Framing Connectors

Single Open Joist TRIFORCE® - U.S./Allowable Load (lbs)

Joist Height	Top Flange						Face Mount						45° Skew								
	Model	B Dim	Fastener Type		Uplift (160)	Down Load	Model	B Dim	Fastener Type		Uplift (160)	Down Load	Model	B Dim	Fastener Type		Uplift (160)	Down Load			
			Header	Joist	DF	SPF			Header	Joist	DF	SPF			Header	Joist	DF	SPF			
Joist Width = 2½"																					
9 ¼	ITS2.56/9.25	2	6-10d	—	105	1520	1150	IUS2.56/9.25	2	8-10d	—	75	950	815	SUR/L2.56/9	3⅜	14-16d	2-10dx1½	195	2015	1735
11 ⅞	ITS2.56/11.88	2	6-10d	—	105	1520	1150	IUS2.56/11.88	2	10-10d	—	75	1185	1020	SUR/L2.56/11	3⅜	16-16d	2-10dx1½	195	2305	1980
14	ITS2.56/14	2	6-10d	—	105	1520	1150	IUS2.56/14	2	12-10d	—	75	1420	1220	SUR/L2.56/14	3⅜	18-16d	2-10dx1½	195	2590	2230
16	ITS2.56/16	2	6-10d	—	105	1520	1150	IUS2.56/16	2	14-10d	—	75	1660	1425	SUR/L2.56/14	3⅜	18-16d	2-10dx1½	195	2590	2230
Joist Width = 3½"																					
9 ¼	ITS3.56/9.25	2	6-10d	—	105	1520	1150	MIU3.56/9	2	16-10d	2-10dx1½	180	2305	1980	SUR/L410	2⅝	14-16d	6-16d	1120	2015	1735
11 ⅞	ITS3.56/11.88	2	6-10d	—	105	1520	1150	IUS3.56/11.88	2	12-10d	—	75	1420	1220	SUR/L410	2⅝	14-16d	6-16d	1120	2015	1735
14	ITS3.56/14	2	6-10d	—	105	1520	1150	IUS3.56/14	2	12-10d	—	75	1420	1220	SUR/L414	2⅝	18-16d	8-16d	1520	2500	2150
16	ITS3.56/16	2	6-10d	—	105	1520	1150	IUS3.56/16	2	14-10d	—	75	1660	1425	SUR/L414	2⅝	18-16d	8-16d	1520	2500	2150

Joist Height	Adjustable Height						Field Slope & Skew							
	Model	B Dim	Fastener Type		Uplift (160)	Down Load	Model	B Dim	Fastener Type		Uplift (160)	Down Load		
			Header	Joist	DF	SPF			Header	Joist	DF	SPF		
Joist Width = 2½"														
9 ¼	THAI322²	2¼	6-10d	2-10dx1½	—	1715	1590	LSSUH310	3½	14-16d	12-10dx1½	990	1600	1385
11 ⅞	THAI322²	2¼	6-10d	2-10dx1½	—	1715	1590	LSSUH310	3½	14-16d	12-10dx1½	990	1600	1385
14	THAI322²	2¼	6-10d	2-10dx1½	—	1715	1590	LSSUH310	3½	14-16d	12-10dx1½	990	1600	1385
16	See Wood Construction Connectors catalog for hanger selection.						See Wood Construction Connectors catalog for hanger selection.							
Joist Width = 3½"														
9 ¼	THAI422²	2¼	6-10d	2-10dx1½	—	1715	1590	LSSU410	3½	14-16d	12-10dx1½	990	1625	1365
11 ⅞	THAI422²	2¼	6-10d	2-10dx1½	—	1715	1590	LSSU410	3½	14-16d	12-10dx1½	990	1625	1365
14	THAI422²	2¼	6-10d	2-10dx1½	—	1715	1590	LSSU410	3½	14-16d	12-10dx1½	990	1625	1365
16	See Wood Construction Connectors catalog for hanger selection.						See Wood Construction Connectors catalog for hanger selection.							

- 1) Shaded hangers require web stiffeners at joist ends. Web stiffeners may be required for non-shaded hangers by joist manufacturer.
- 2) THAI hangers require a minimum of 4 top and 2 face nails installed.
- 3) The B Dim is the length of the hanger seat.

ITS - 18 gauge

The ITS top flange hanger with its Strong-Grip™ seat and Funnel Flange™ secures joists with flange thicknesses from 11/8" - 11/2" and installs faster than any other top flange hanger. Joist nails are not required.

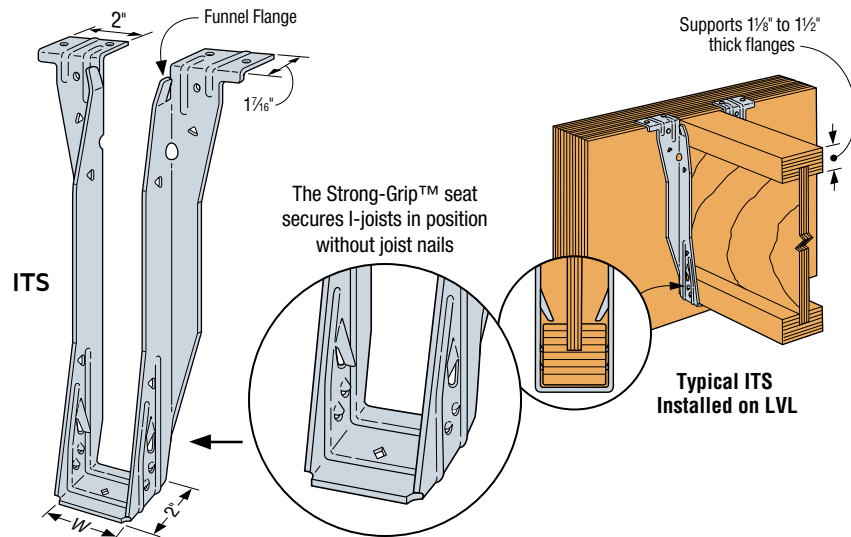

IUS - 18 gauge

The IUS is a hybrid hanger that incorporates the advantages of face-mount and top-flange hangers. Joist nails are not required.

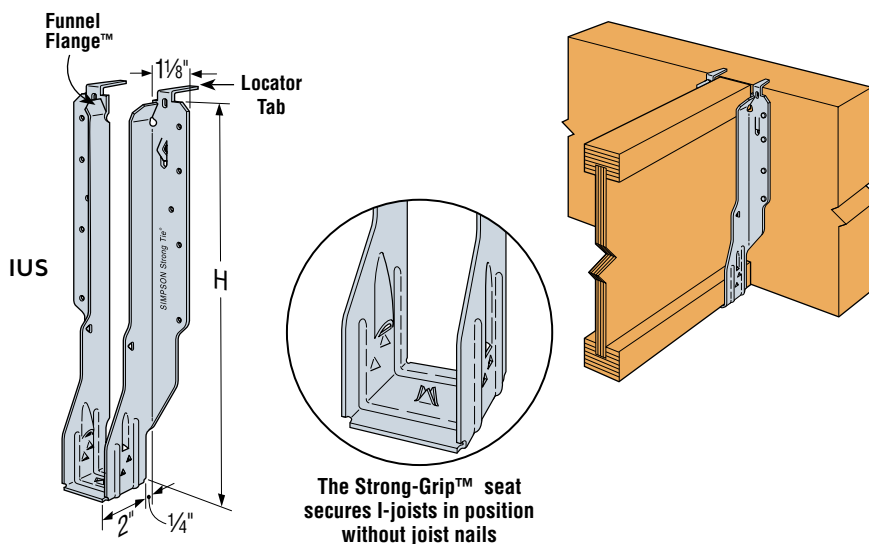

SUR/L - 16 gauge HSUR/L - 14 gauge

All models are skewed 45°. Normally accommodates a 40° - 50° skew. The installation of these hangers does not require a beveled end cut.

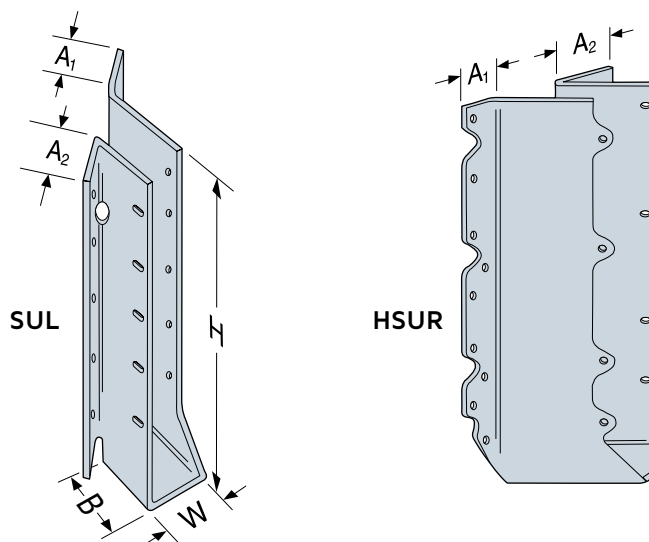

THAI - 18 gauge

This hanger has extra long straps and can be field-formed to give height adjustability and top flange hanger convenience. Positive angle nailing helps minimize splitting of the joist's bottom flange. Minimum nailing is shown in the table above. Strap must be field-formed over the top of the header by a minimum of 21/2". Web stiffeners required when used with joists.

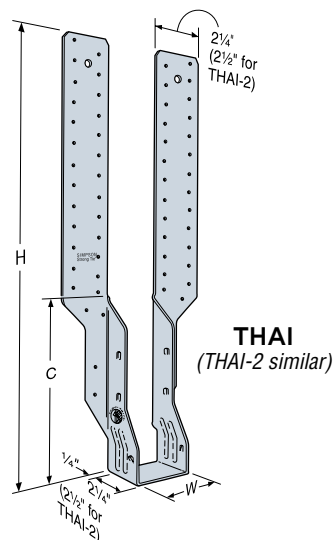

Typical THAI Installation with Minimum Nailing Configuration

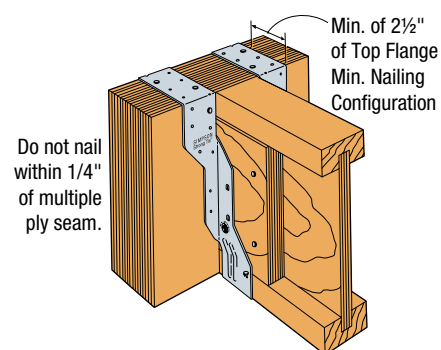

Double Framing Connectors

Double Open Joist TRIFORCE® - U.S./Allowable Load (lbs.)

Joist Height	Top Flange						Face Mount						45° Skew								
	Model	B Dim	Fastener Type		Uplift (160)	Down Load		Model	B Dim	Fastener Type		Uplift (160)	Down Load		Model	B Dim	Fastener Type		Uplift (160)	Down Load	
			Header	Joist		DF	SPF			Header	Joist		DF	SPF			Header	Joist		DF	SPF
Joist Width = 5"																					
9/4	LBV5.12/9.25	2 1/2	10-16d	2-10dx1 1/2	230	2590	2060	MIU5.12/9	2 1/2	16-16d	2-10dx1 1/2	180	2305	1980	HSUR/L5.12/9	2 9/16	12-16d	2-10dx1 1/2	140	1785	1540
11 1/8	MIT311.88-2	2 1/2	8-16d	2-10dx1 1/2	185	2305	1665	MIU5.12/11	2 1/2	20-16d	2-10dx1 1/2	180	2880	2475	HSUR/L5.12/11	2 9/16	16-16d	2-10dx1 1/2	140	2380	2050
14	MIT314-2	2 1/2	8-16d	2-10dx1 1/2	185	2305	1665	MIU5.12/14	2 1/2	22-16d	2-10dx1 1/2	180	3170	2725	HSUR/L5.12/14	2 9/16	20-16d	2-10dx1 1/2	140	2975	2565
16	MIT5.12/16	2 1/2	8-16d	2-10dx1 1/2	185	2305	1665	MIU5.12/16	2 1/2	24-16d	2-10dx1 1/2	180	3455	2970	HSUR/L5.12/16	2 9/16	24-16d	2-10dx1 1/2	140	3330	2865
Joist Width = 3 1/2"																					
9/4	B7.12/9.25	2 1/2	14-16d	6-16d	870	3800	2650	HU410-2	2 1/2	18-16d	8-16d	1540	2680	2305	HU410-2x ^s	2 1/2	18-16d	8-16d	1155	2145	1845
11 1/8	B7.12/11.88	2 1/2	14-16d	6-16d	870	3800	2650	HU412-2	2 1/2	22-16d	8-16d	1540	3275	2820	HU412-2x ^s	2 1/2	22-16d	8-16d	1155	2620	2255
14	B7.12/14	2 1/2	14-16d	6-16d	870	3800	2650	HU414-2	2 1/2	26-16d	12-16d	2315	3870	3330	HU414-2x ^s	2 1/2	26-16d	12-16d	1735	3095	2665
16	B7.12/16	2 1/2	14-16d	6-16d	870	3800	2650	HU414-2	2 1/2	26-16d	12-16d	2315	3870	3330	HU414-2x ^s	2 1/2	26-16d	12-16d	1735	3095	2665

Joist Height	Adjustable Height						Field Slope & Skew							
	Model	B Dim	Fastener Type		Uplift (160)	Down Load		Model	B Dim	Fastener Type		Uplift (160)	Down Load	
			Header	Joist		DF	SPF			Header	Joist		DF	SPF
Joist Width = 5"														
9/4	THAI-2 ^s	2 1/2	6-10d	2-10dx1 1/2	—	2020	2020	LSU5.12 ^a	3 1/2	24-16d	16-10dx1 1/2	760	1790	1550
11 1/8	THAI-2 ^s	2 1/2	6-10d	2-10dx1 1/2	—	2020	2020	LSU5.12 ^a	3 1/2	24-16d	16-10dx1 1/2	760	1790	1550
14	THAI-2 ^s	2 1/2	6-10d	2-10dx1 1/2	—	2020	2020	LSU5.12 ^a	3 1/2	24-16d	16-10dx1 1/2	760	1790	1550
16	See Wood Construction Connectors catalog for hanger selection.						See Wood Construction Connectors catalog for hanger selection.							
Joist Width = 7"														
9/4	See Wood Construction Connectors catalog for hanger selection.						See Wood Construction Connectors catalog for hanger selection.							
11 1/8														
14														
16														

- 1) Shaded hangers require web stiffeners at joist ends. Web stiffeners may be required for non-shaded hangers by joist manufacturer.
- 2) The B Dim is the length of the hanger seat.
- 3) THAI hangers require a minimum of 4 top and 2 face nails installed. THAI-2 must be special ordered. Specify hanger seat width between 3/8" and 5 5/16".
- 4) LSU's can not be field skewed. Skew option must be factory ordered, specify skew angle.
- 5) Skew option must be special ordered. Specify skew angle and direction (e.g. HU412-2x, SKR45°).

B - 12 gauge LBV - 14 gauge

The B series offers versatility for joists and SCL lumber. Enhanced load capacity widens the range of applications for these hangers. The LBV is designed especially for use with multiple ply headers 1 1/2" to 1 3/4" thick, and may be used for weld-on applications.

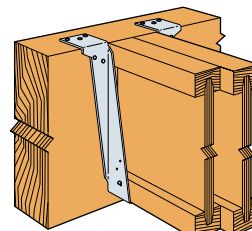
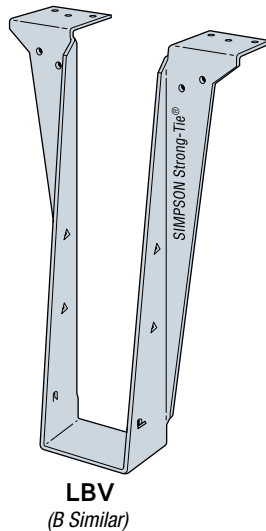

Typical Double LBV Hanger Installation

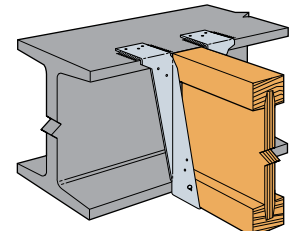

BA, B, HB and LBV are acceptable for weld-on applications (LBV shown). See Installation Information.

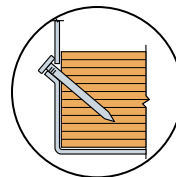

LBV features positive angle nailing, no web stiffeners are required

MIT - 16 gauge

The MIT's Positive Angle Nailing helps minimize splitting of the joist's bottom flange. Features uplift capacity and extended seat design (to allow installation of slightly undercut joists).

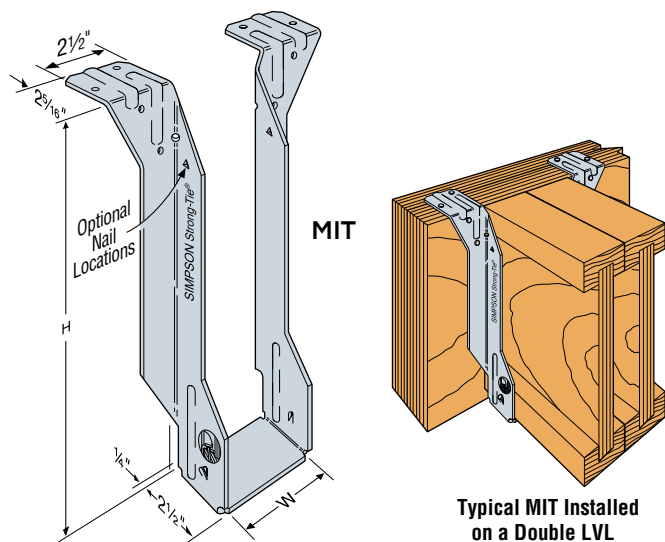

MIU - 16 gauge

The MIU series features 16 gauge steel and extra nailing for higher loads.

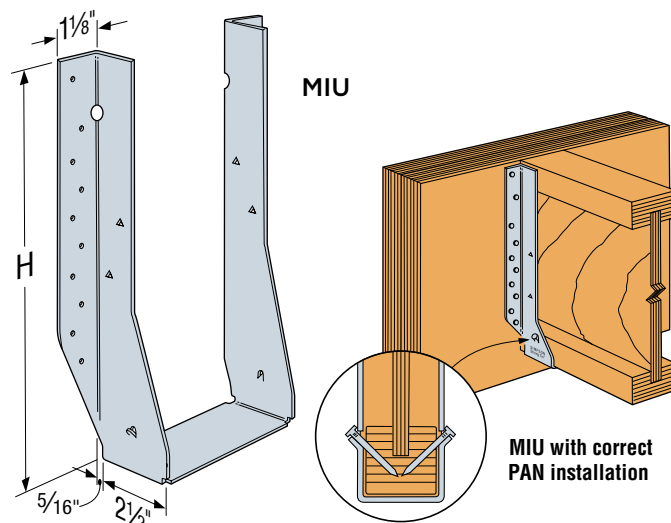

HU - 14 gauge

The HU series features uplift capacity and a large selection of sizes and load ranges. HU hangers have triangle holes that can be filled for increased loads. Web stiffeners required when used with joists.

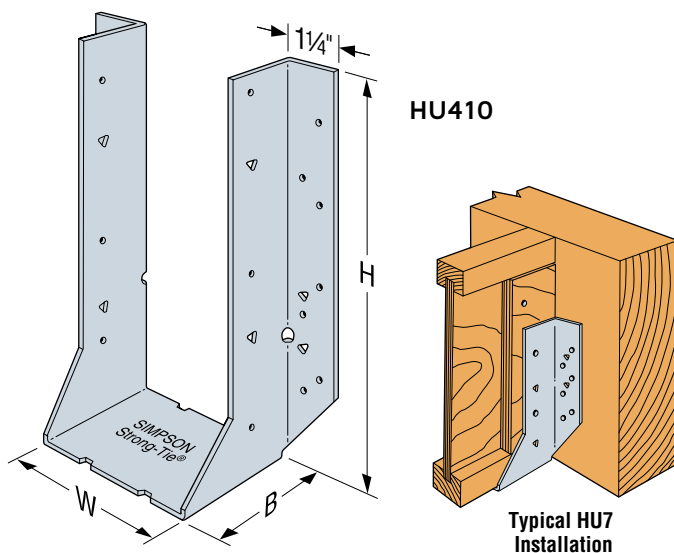

LSSU, LSSUI - 18 gauge LSSU210-2, LSSU410 and LSSUH310 - 16 gauge LSU - 14 gauge

LSSU models provide uplift capacity and can be field sloped and/or skewed to 45°. Web stiffeners required when used with joists; cut web stiffener to match angle on sloped conditions.

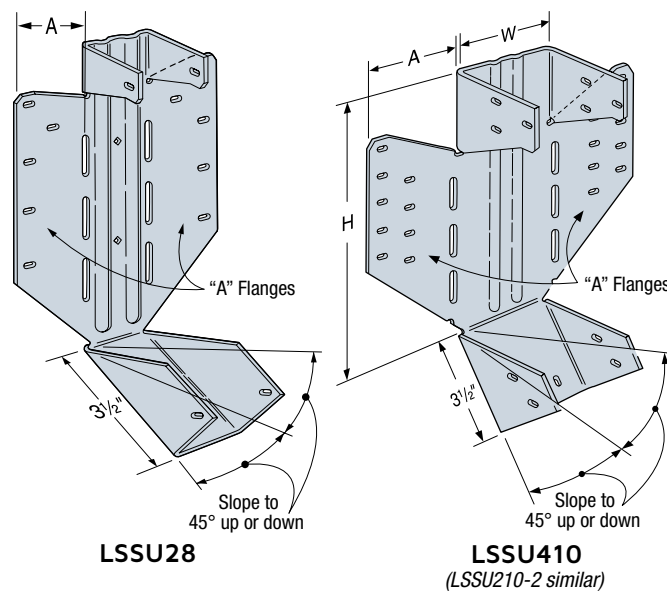

Warranty



Product warranty

Products manufactured by Barrette Structural Inc. (hereafter: "Barrette Structural") are guaranteed against manufacturing and material faults for the life of the structure.

This limited lifetime warranty is applicable if the products manufactured by Barrette Structural have been correctly stored, protected from climatic conditions such as sunlight, humidity, rain or wind, and installed in conformity with the guidelines and instructions supplied, either as floor joists or roof trusses, whichever is the case.

This warranty does not cover perceived problems of design or defects caused by:

- prolonged exposure to water or climatic conditions (in particular following construction work or due to construction delays), fire, flooding, natural disasters or any other cause beyond the control of Barrette Structural;
- faults in the structure following poor construction, installation or assembly practices;
- damage to the structure before, during or after installation;
- failure to respect installation instructions, current building code norms or generally accepted practices in the construction industry;
- the transformation of joists or roof trusses after their initial installation;
- the presence of mold, spore, rot or termites or any other element likely to degrade the installed product;
- the application of a preservative treatment or any other coating not approved by Barrette Structural;
- defective ventilation, repeated exposure to water or humid conditions;
- excessive loads or tension not allowed for by Barrette Structural or usage that does not comply with the type for which the product was designed.

IN THE CASE OF PROBLEMS WITH MANUFACTURING FAULTS COVERED BY THIS WARRANTY, BARRETTE STRUCTURAL WILL PAY REASONABLE COSTS FOR LABOR AND MATERIALS TO REPAIR OR REPLACE ONLY THE JOISTS OR ROOF TRUSSES UNDER WARRANTY. THESE COSTS MUST NOT EXCEED BY MORE THAN THREE TIMES THE INITIAL PURCHASE COST OF THE JOISTS OR ROOF TRUSSES INVOLVED IN THE CLAIM.

IN THE EVENT OF A CLAIM, THE RESPONSIBILITY OF BARRETTE STRUCTURAL IS LIMITED TO THAT WHICH HAS BEEN OUTLINED IN THIS WARRANTY. BARRETTE STRUCTURAL MAY NOT BE HELD RESPONSIBLE FOR ANY OTHER DAMAGE WHATSOEVER.

All claims must be communicated to Barrette Structural within 30 days of the discovery of any anomaly or problem covered by this warranty, at the following address:

BARRETTE STRUCTURAL
555, rang Saint-Malo, Trois-Rivières (Québec) G8V 0A8 CANADA

To obtain further information, please contact your representative.

Peace of mind underfoot™

www.openjoisttriforce.com