

KEYNOTE EXPLANATION

- 03000 AS EXISTING CONCRETE FLOOR SLAB.
- 044023 P2 PLASTIC LAMINATE GLD BND PANEL.
- 044023 S1 PROVIDE RUBBER GASKET SHIELD AT EACH VERIFY EXACT LOCATION OF HOLES WITH ARCHITECT.
- 081250 A1 DOUBLE RUBBER ALUMINUM DOOR POWER.
- 081250 D2 SH11 AS REBUILT.
- 092900 B1 5/8" GYPSUM BOARD.
- 092900 F2 3-5/8" METAL STUD REMAINING AT 16" O. C.
- 092900 C1 VINYL FLOOR ESSEL/TRANSITION.
- 09616 C1 HEAT INSULATED SHEET VINYL FLOORING WITH REINFORCING BASE.
- 09616 D2 RUBBER FILLET STRIP.
- 09616 D3 METAL CARPING STRIP.
- 09619 A1 RESILIENT FLOOR TILE TYPE 1.
- 09680 A1 CARPET TYPE A.
- 09680 B1 CARPET DAMP.
- 104400 B1 FILE FILING CABINET(S) FINISHED BY OWNER.
- 110050 G2 INSTALLED BY OWNER.
- 110050 V2 AUTOCLAVE, FINISHED BY OWNER, INSTALLED BY CONTRACTOR.
- 110250 N1 BED PROVIDED AND INSTALLED BY OWNER.
- 110250 N2 OR TABLE, FINISHED BY OWNER, INSTALLED BY CONTRACTOR.
- 110250 N3 INKOR WALL WATER CONTAIN, FINISHED BY OWNER, FINISHED BY OWNER, INSTALLED BY CONTRACTOR.
- 110250 R1 WASTER, FINISHED BY OWNER, INSTALLED BY OWNER, FINISHED BY OWNER, INSTALLED BY CONTRACTOR.
- 110250 S2 DRESS, FINISHED BY OWNER, INSTALLED BY CONTRACTOR.

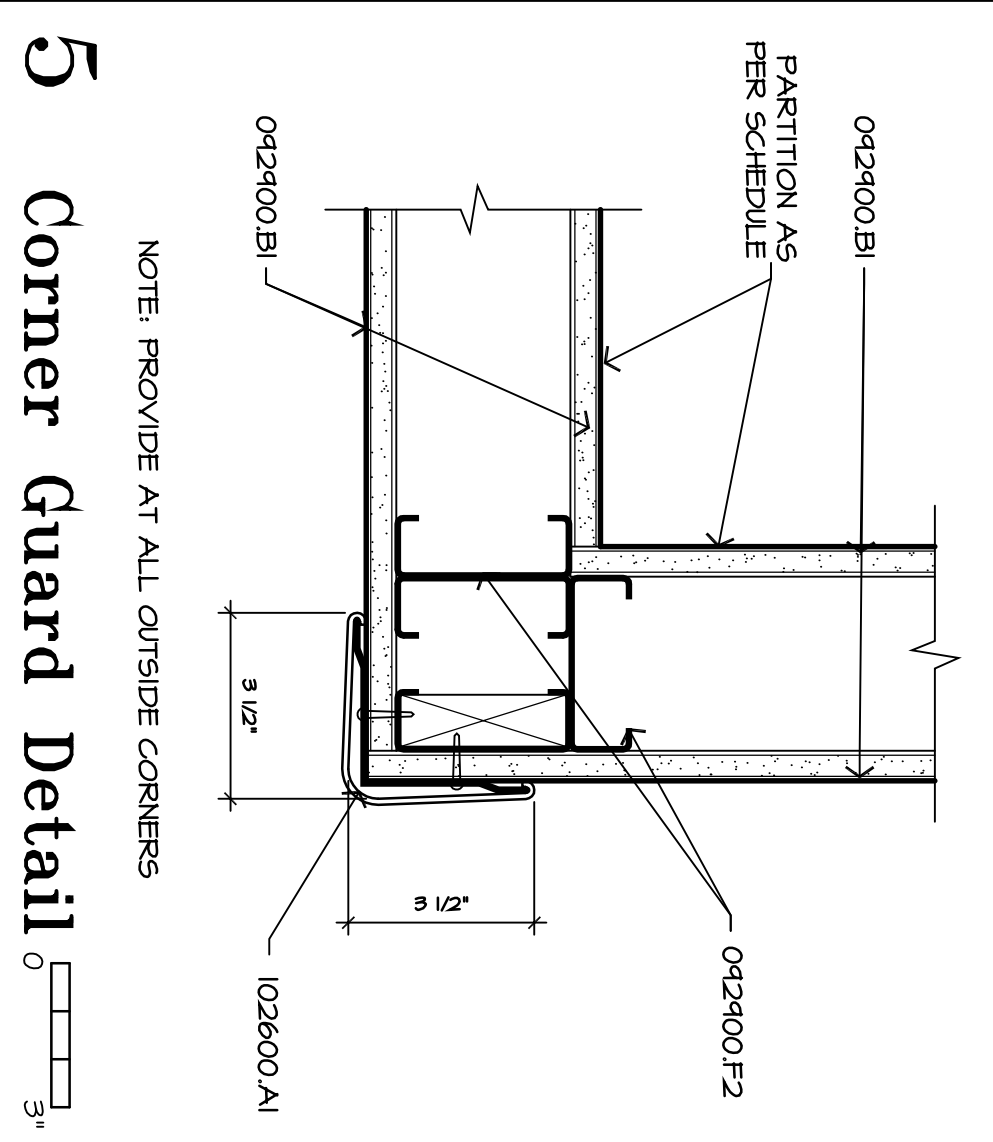

5 Corner Guard Detail

NOTE: PROVIDE AT ALL OUTSIDE CORNERS

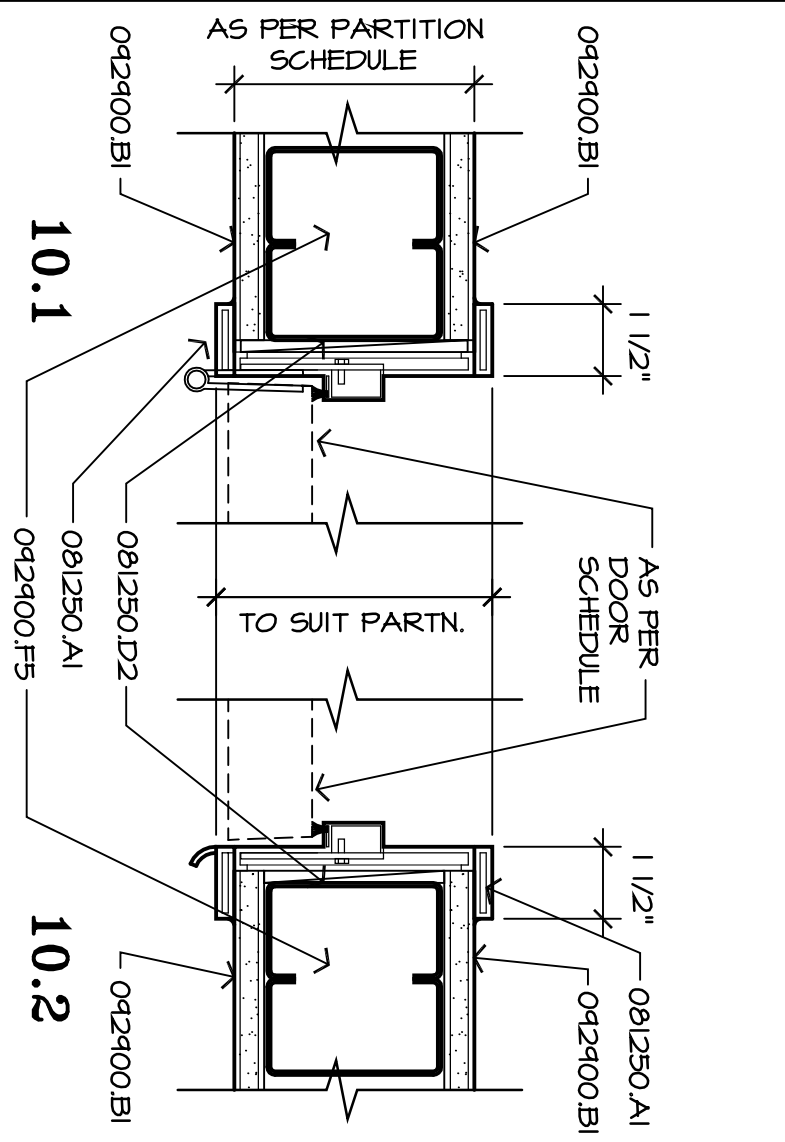

10 Interior Aluminum Door Jamb

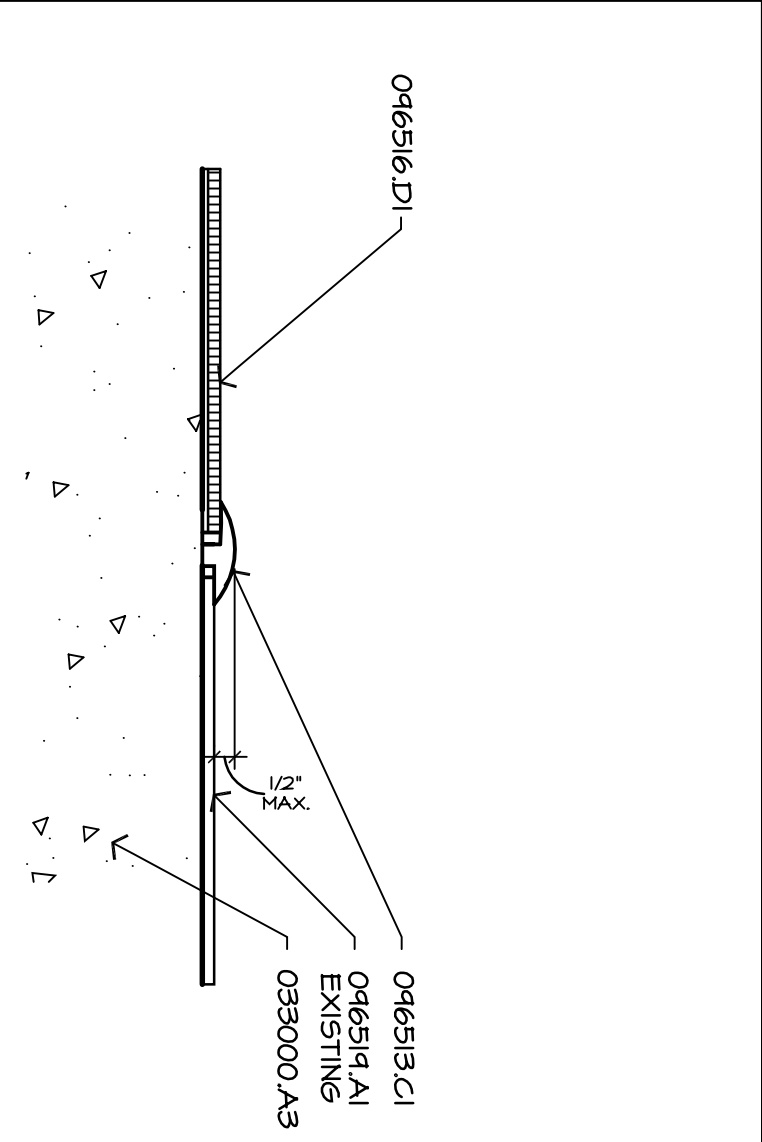

15 Transition @ Sheet Vinyl/Resilient Tile

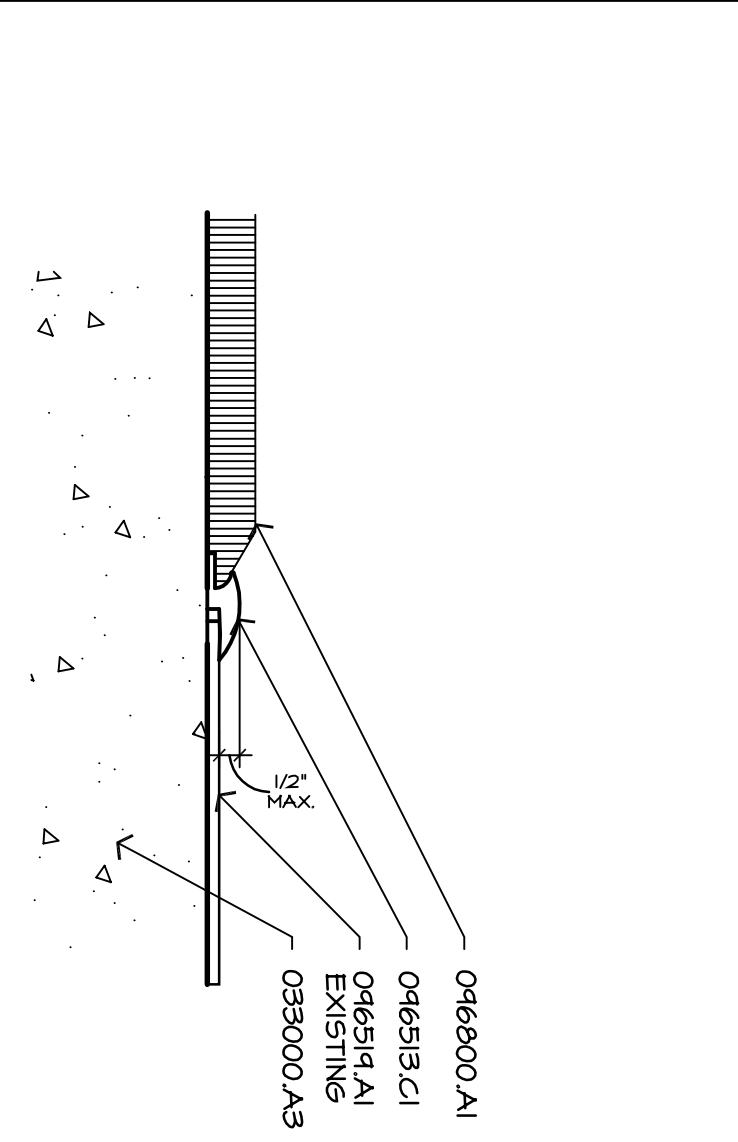

20 Transition @ Carpet/Resilient Tile

- General Notes**
1. NEW GYPSUM WALLBOARD CONSTRUCTION. MEETS EXISTING CONSTRUCTION. PARTITION SAME PLANE SHALL BE FINISH WITHOUT VISIBLE JOINTS SHOWING.
 2. ALL PIPE, DUCTWORK, AND PNEUMATIC TUBES PENETRATING THROUGH FIRE RATED FLOOR SLABS AND PARTITIONS SHALL BE SLEEVED EXCEPT WHERE SHAFTS OR OPENINGS ARE PROVIDED. VOIDS IN SLEEVES SHALL BE PACKED TIGHT WITH A FIRE RESISTIVE MATERIAL THAT MEETS OR EXCEEDS THE ASSEMBLY BEING PENETRATED. THE DIMENSIONS ARE TO FACE OF FINISH UNLESS NOTED OTHERWISE.
 3. NOTED OTHERWISE.

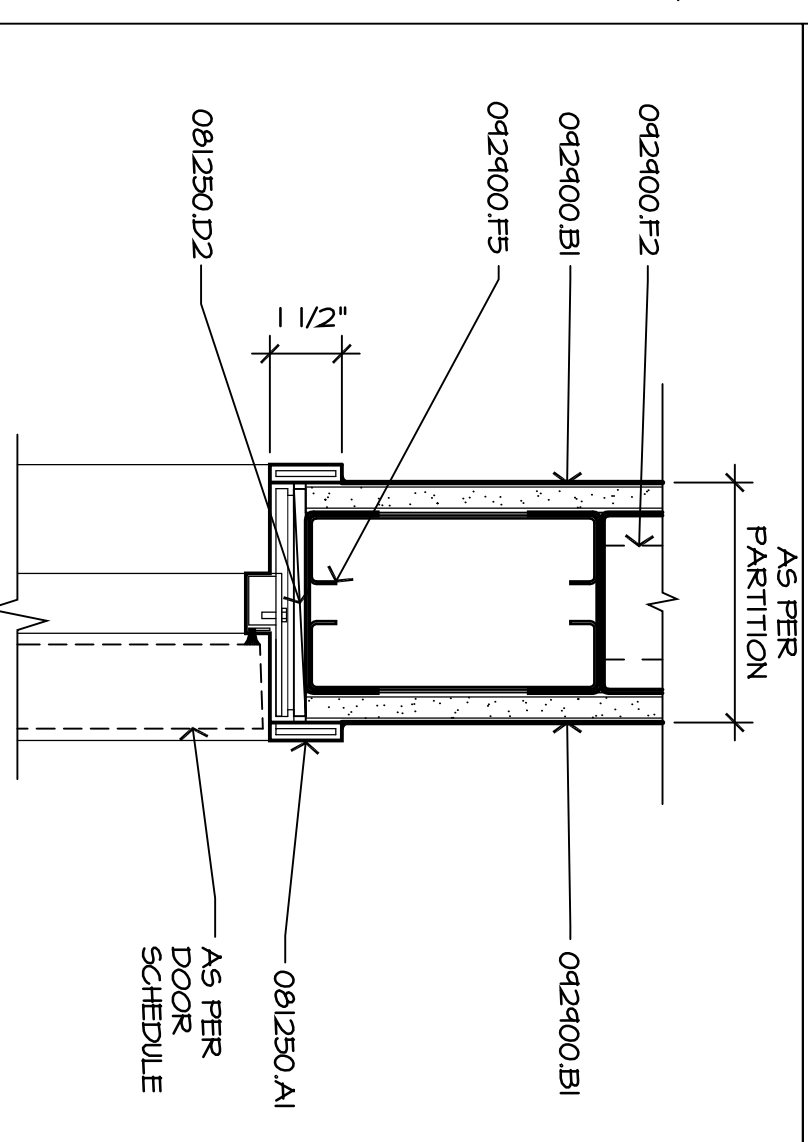

9 Interior Aluminum Door Head

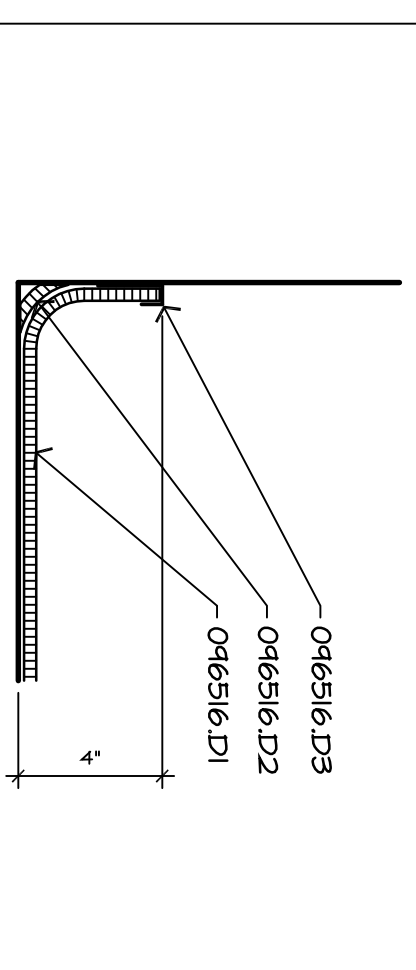

14 Coved Sheet- Vinyl Base Partition Legend

ALL PARTITIONS TYPE P1 UNLESS OTHERWISE NOTED

--- TYPICALLY INDICATES SOUND PARTITION TO INSIDE OF DECK

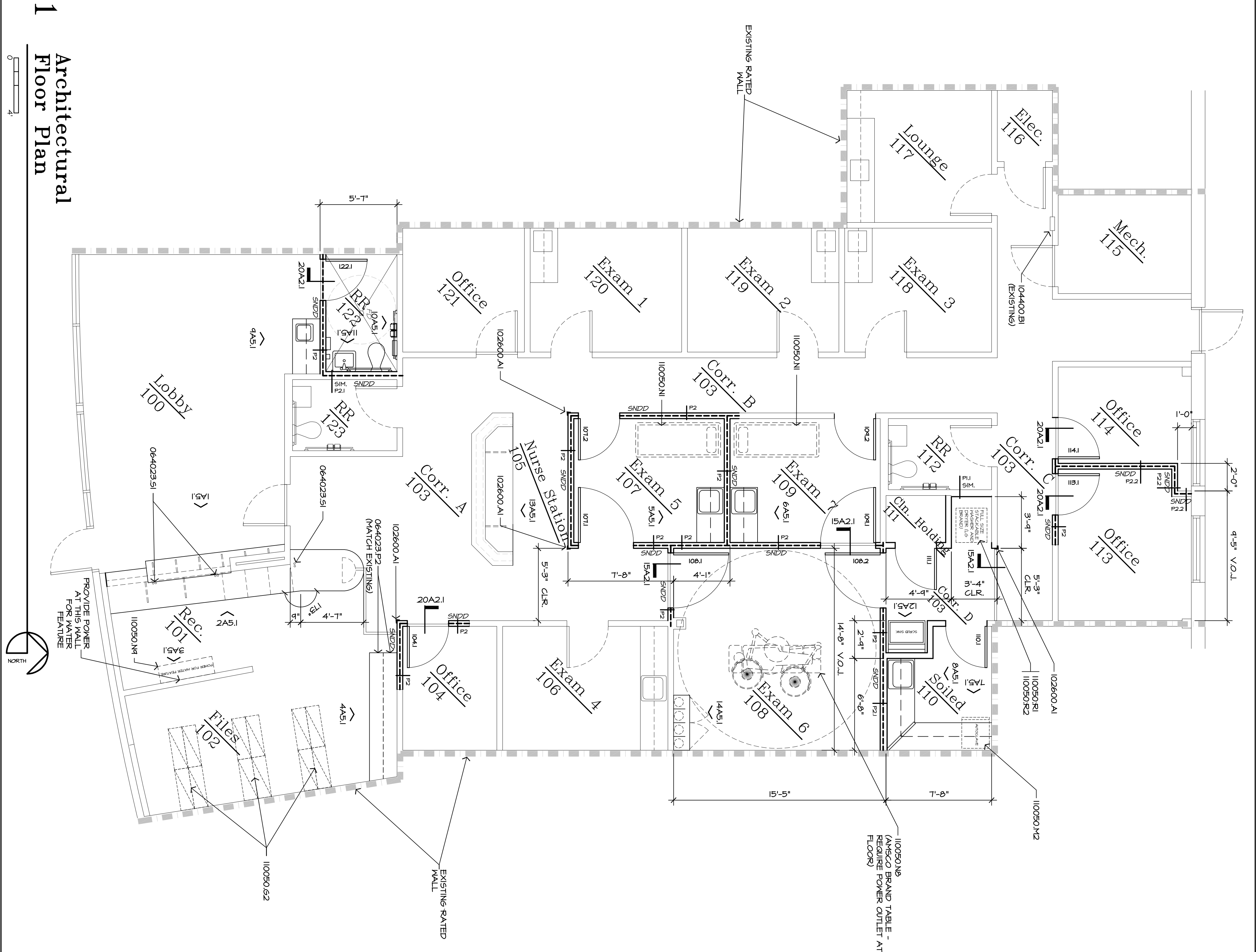

Medical Office Suite
 Tenant Improvement for Dr. Bertrek, Suite D
 Slidell, LA.

DATE	REVISION	NOTES
09/16/10		

ARCHITECTS SOUTHWEST
 A Professional Corporation
 LAURENCE J. JIA
 (857) 887-2411

KEY PLAN

© 2010 - Architects Southwest