

SECTION III SOUND CONTROL

SOUND INSULATION

The first essential for airborne sound insulation using any system is to close off air leaks and/or flanking paths by which noise can go through or around the system. Small cracks or holes will increase the sound transmission at the higher frequencies. This can have a detrimental effect on the overall acoustical performance and the STC, particularly for higher rated systems. Failure to observe special construction and design precautions can reduce the effectiveness of the best planned sound control methods.

Systems shall be airtight. Recessed wall fixtures, such as medicine cabinets or electrical, telephone, television, and intercom outlets, that penetrate the gypsum board shall not be located back-to-back or in the same stud cavity. Any opening for fixtures or pipes shall be

cut to the proper size and sealed. The entire perimeter of a sound insulating system shall be made airtight to prevent sound flanking. Flexible sealant or an acoustical gasket shall be used to seal between the STC rated system and all dissimilar surfaces and also between the system and similar surfaces where perimeter relief is required. TAPING GYPSUM BOARD WALL AND WALL-CEILING INTERSECTIONS PROVIDES AN ADEQUATE AIR SEAL AT THESE LOCATIONS. ASTM E 497, *Standard Practice for Installing Sound-Isolating Lightweight Partitions*, provides additional information. Consult the manufacturer of the gypsum board for any special recommendations.

Systems are grouped in ranges according to their Sound Transmission Class (STC) or Field Sound Transmission Class (FSTC). The

higher ranges are shown first. All of the sound tests referenced were conducted according to the requirements of ASTM E 90, for laboratory tests, or ASTM E 336, for field tests. The designer shall adhere to the specified materials and construction details for STC and FSTC rated systems, particularly in plaster systems, because substitution of lightweight aggregates for sand, or reduction of the sand proportion, may reduce the rating. ALL OPENINGS THROUGH THE SYSTEM, AND ITS ENTIRE PERIMETER, SHALL BE SEALED AIRTIGHT.

SUBSTITUTING MECHANICAL FASTENERS FOR ADHESIVES, OR THE USE OF MORE FASTENERS, MAY AFFECT THE RATING.

Details of sound tests issued by sound testing agencies are on file and a summary is available from the Gypsum Association or the test sponsor.

Figure 11 shows three typical resilient channel configurations. Where resilient channels are included in systems, the resilient channels are shown by a dashed line to distinguish them from rigid furring channels. Figure 12 distinguishes between standard construction practices and those practices recommended for improved sound control.

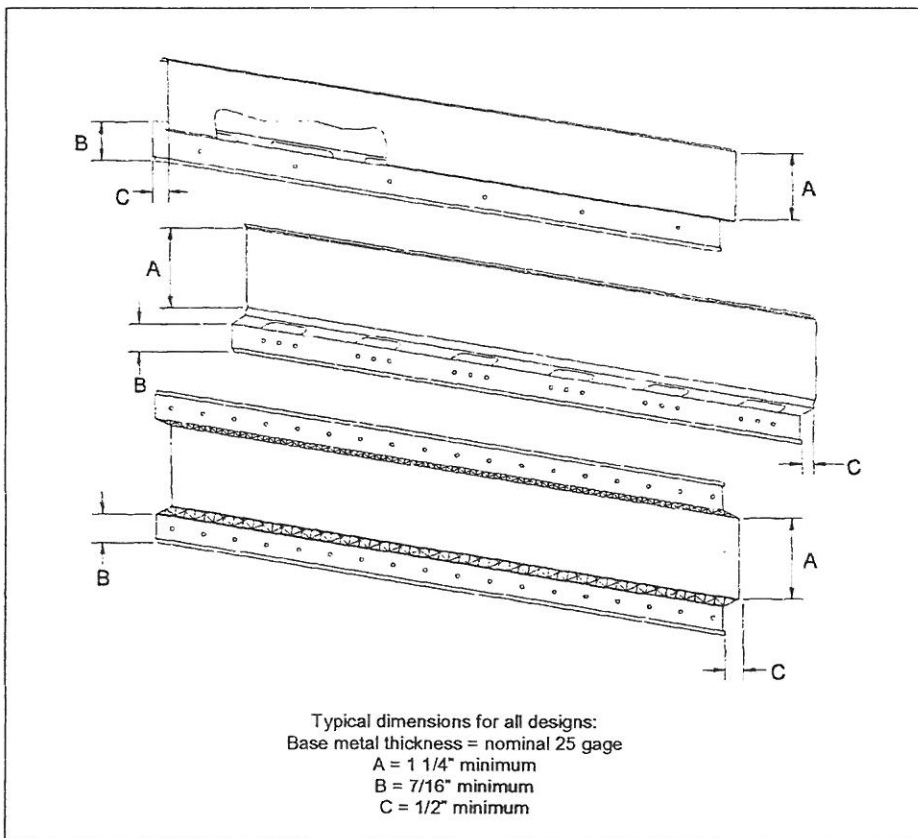
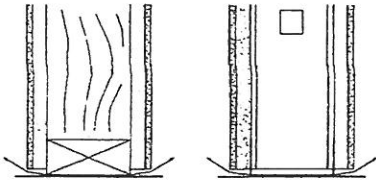
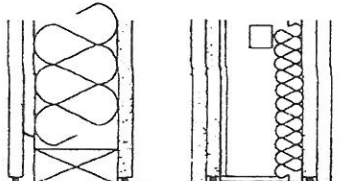
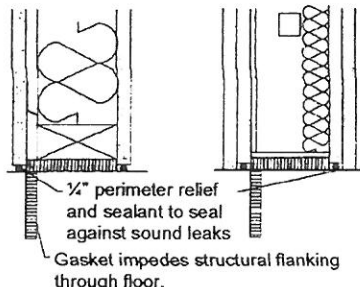
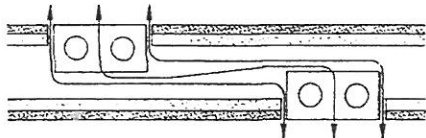
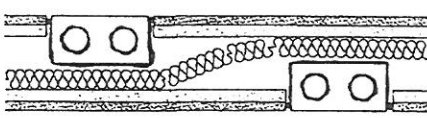
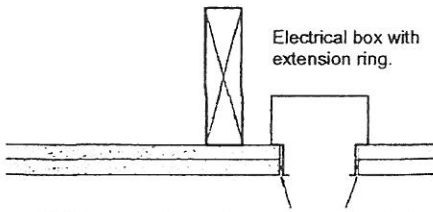
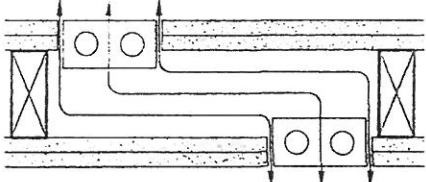
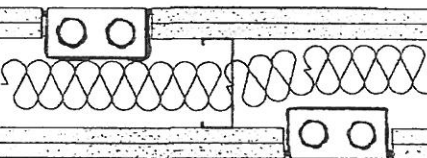
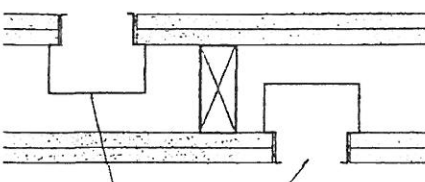
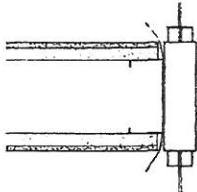
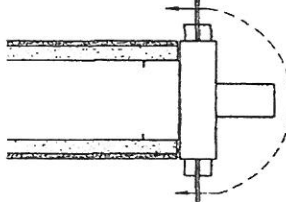
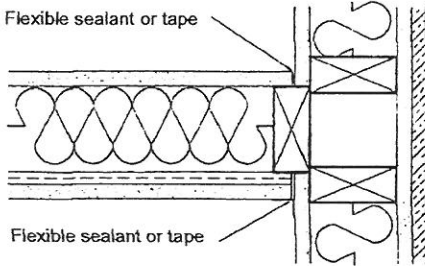
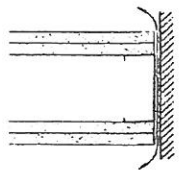
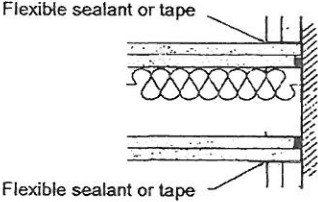
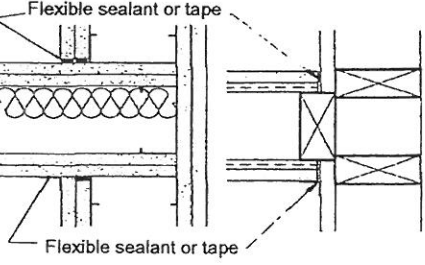

Figure 11
Resilient Furring Channels

Figure 12
Sound Isolation Construction

<p>"NORMAL" CONSTRUCTION ARROWS SHOW FLANKING PATHS</p>	<p>"SELECT" CONSTRUCTION SEALING OF RELIEF DETAIL AT PERIMETER OF PARTITION AND AROUND CUT-OUTS TO PREVENT SOUND LEAKAGE</p>	<p>"PRE-DESIGN" CONSTRUCTION SIMULATED LABORATORY CONDITIONS</p>
 <p>Wood stud system Steel stud system</p> <p>ELEVATION Under and over partitions</p>	 <p>Wood stud system Steel stud system</p> <p>ELEVATION Flexible sealant</p>	 <p>1/2" perimeter relief and sealant to seal against sound leaks Gasket impedes structural flanking through floor.</p> <p>ELEVATION</p>
 <p>PLAN Through-partition openings outlet boxes</p>	 <p>PLAN Sealing of openings through partitions</p>	 <p>Electrical box with extension ring.</p> <p>Void between box and gypsum board sealed</p> <p>ELEVATION Typical floor-ceiling or roof detail</p>
 <p>PLAN Through-partition openings outlet boxes</p>	 <p>PLAN Boxes offset one stud space and sealing of openings through partitions</p>	 <p>Offset boxes with extension rings and sealed openings</p> <p>PLAN Outlet box detail</p>
 <p>PLAN Flanking at partition-mullion intersection</p>	 <p>PLAN Typical partition-mullion intersection</p>	 <p>Flexible sealant or tape</p> <p>Flexible sealant or tape</p> <p>PLAN Intersection with exterior wall</p>
 <p>PLAN Metal Stud Around-flanking partition ends</p>	 <p>Flexible sealant or tape</p> <p>Flexible sealant or tape</p> <p>PLAN Intersection with interior wall</p>	 <p>Flexible sealant or tape</p> <p>Flexible sealant or tape</p> <p>PLAN Typical partition intersection</p>

**SOUND TRANSMISSION
LOSS TESTS**

ASTM E 90, *Standard Test Method for Laboratory Measurement of Airborne Sound Transmission Loss of Building Partitions*, is the procedure for measuring the sound transmission loss (STL) in a laboratory. The STL is the difference between the sound energy (sound pressure level) in a source room and a receiving room when the two rooms are separated by the system being tested.

ASTM E336, *Standard Test Method for Measurement of Airborne Sound Insulation in Buildings*, is the procedure to determine the field sound transmission loss (FSTL) between two rooms under field conditions.

The STL or the FSTL is measured at 1/3 octave test frequencies (Hz) as follows and the sound transmission loss curve is plotted:

125	315	800	2000
160	400	1000	2500
200	500	1250	3150
250	630	1600	4000

A system's overall effectiveness in resisting the transmission of airborne sound, whether it is a wall, partition, or floor-ceiling, is reported as a single number derived from an analysis of the STL or FSTL curve. This rating is the Sound Transmission Class (STC) or Field Sound Transmission Class (FSTC). This Manual uses STC/FSTC ranges to make comparing systems more significant.

ASTM E413, *Classification for Rating Sound Insulation*, is the method used to derive the STC/FSTC from the STL/FSTL curve. Using the rules stated in ASTM E 413, a reference contour is fitted to the sound transmission loss curve. The STC/FSTC is the point where the reference contour crosses the 500 Hz line.

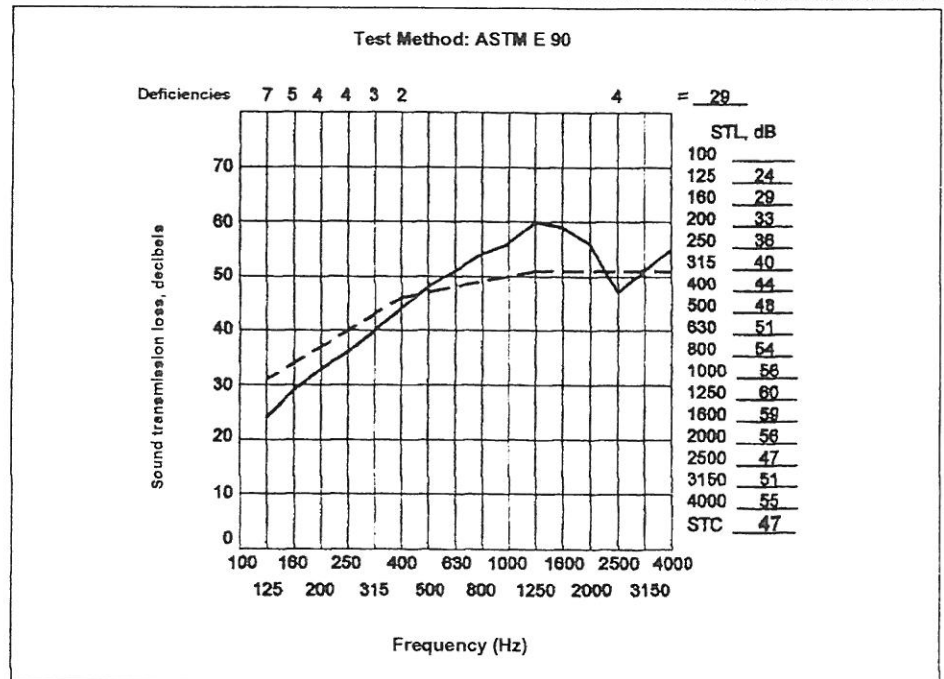

Figure 13
STL Curve

The reference contour, shown by the dashed line in Figure 13, has a flat portion from 4000 Hz to 1250 Hz. It drops 5 dB between 1250 Hz and 400 Hz, and 15 dB between 400 Hz and 125 Hz. In fitting the reference contour to the measured curve, the following conditions are required to be met:

1. The STL curve is not permitted to be greater than 8 dB below the reference contour at any test frequency, and
2. The sum of the dB differences between the points on the reference contour and the corresponding points on the STL curve at each of the test frequencies is not permitted to be greater than 32 dB.

Some of the STC ratings in this Manual were derived according to slightly different standards in use prior to 1970. For instance, ASTM E 90-61T, the previous sound test procedure, called for measurements at 1/2 octave frequencies, and the rules for fitting the standard curve were different.

The smallest dimension of the system tested in accordance with ASTM E 90 is not permitted to be less than 7 feet, 10 inches and the minimum volume for each of the sound source and receiving rooms is 2,825 cubic feet. The system is constructed to separate the source and receiving rooms, which are arranged so that the only significant sound transmission is through the test specimen.

The source room contains one or more sound sources, a diffusing system such as multiple stationary and/or rotating reflectors, and microphones located to adequately sample the sound field in the space. A single microphone on a rotating boom may be optionally used. The receiving room is similarly equipped, except that the sound source(s) is used only to determine the reverberation time for correction purposes. The sound measurements in both rooms are made according to ASTM E 90.

Research by recognized sound test authorities indicates that the STC's on unsymmetrical walls are not affected by sound testing from either side. Therefore, the laboratory sound source side is not indicated for unsymmetrical systems in this Manual.

IMPACT NOISE TEST

To determine the Impact Insulation Classification (IIC) of a floor, a standard ISO impact machine with steel hammers taps on a test floor system installed above a special receiving room. Microphones in the receiving room record the average sound pressure level produced by the tapping machine at 1/3 octave frequency bands between 100 and 3150 Hz. These measured levels are then normalized to a standard room absorption. The method used is described in ASTM E 492, *Standard Test Method for Laboratory Measurement of Impact Sound Transmission Through Floor-Ceiling Assemblies Using the Tapping Machine*.

The IIC is determined by comparing the normalized impact sound pressure levels at the 16 test frequencies with an IIC reference contour. The reference contour has a flat portion from 100 to 315 Hz, a middle line segment decreasing 5 dB in the interval 315 to 1000 Hz, followed by a high frequency line segment decreasing 15 dB in the interval 1000 to 3150 Hz. In fitting the reference contour to the measured sound pressure levels in the receiving room, the following conditions are required to be met:

1. The noise level at any test frequency is not permitted to be greater than 8 dB above the reference contour, and
2. The sum of the dB differences between the points on the reference contour and the corresponding points on the curve of the normalized impact noise levels at each of the test frequencies is not permitted to be greater than 32 dB.

The IIC for the specimen is the difference between 110 and the value on the normalized impact noise level scale (i.e., ordinate scale) at 500 Hz of the lowest contour for which the above conditions are fulfilled.

The IIC listings for floor-ceiling systems in this Manual are for bare floors (no floor covering) and for the addition of a carpet over a separate pad, which is identified as "C&P."

Although any carpet, with or without a pad, will improve the IIC, a heavy wool carpet over a good quality pad will make a significant improvement, as illustrated for FC 5300 on page 109. The addition of a 44 oz. woven loop pile carpet over a 40 oz. hair felt pad increased the IIC from 38 to 63. The IIC (C&P) listings in this Manual are for the carpet and pad described above for FC 5300 unless otherwise noted. The use of other types of carpets, both with and without pads, will result in increases in the IIC, and in some instances may equal that achieved by use of the aforementioned carpet and pad.