

# UBB Series Back Bar Refrigerator

REFRIGERATION  
**AVANTCO**

[www.AvantcoRefrigeration.com](http://www.AvantcoRefrigeration.com)

**MODELS** #178UBB60GHC

## UBB SERIES - NARROW DEPTH, GLASS DOOR

Optimize space behind your bar.

### CABINET CONSTRUCTION

Heavy-duty black coated steel exterior with a 304 type stainless steel interior features coved corners for easy clean-up. Self-closing, glass doors come standard with locks to protect contents inside. Durable, 1½" thick stainless steel top for prep and drink service.

Foamed-in-place CFC- and HCFC-free polyurethane insulation enhances the structural strength of the cabinet and helps increase energy efficiency.

### REFRIGERATION SYSTEM

Environmentally safe R290 refrigerant. Side-mounted condensing unit positioned for easy maintenance.

### SHELVING

4 epoxy-coated steel shelves included. Each accommodates up to 90 lb.

### MODEL FEATURES

Preprogrammed digital controller features auto-defrost function. LED lighting ensures optimal product visibility. Accommodates two ½ size kegs. Narrow depth design makes this unit ideal for tight bar spaces.

## SPECIAL FEATURES

- Eco-friendly R290 hydrocarbon refrigerant
- Sleek, black coated steel exterior with glass doors
- 304 type stainless steel interior with coved corners maintains temperatures from 33-40°F
- Four epoxy-coated steel shelves accommodate up to 90 lb. each
- Accommodates up to (2) ½ kegs
- Foamed-in-place polyurethane insulation
- Built-in 1½" stainless steel top
- 115V; 1/5 hp
- Stainless steel interior is food rated and marked with the ETL Sanitation mark



## WARRANTY

RESIDENTIAL: Avantco assumes no liability for parts or labor coverage for component failure, factory defect or any other damages for units installed in non-commercial foodservice or residential applications.



Parts & Labor



Compressor

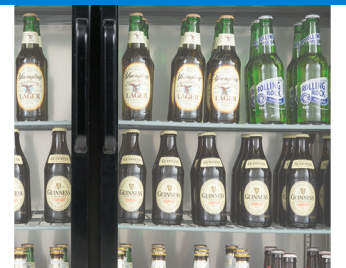
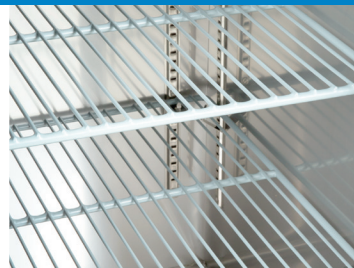

# UBB Series Back Bar Refrigerator



**MODELS** #178UBB60GHC

[www.AvantcoRefrigeration.com](http://www.AvantcoRefrigeration.com)

## TECHNICAL DATA

### Dimensions

Exterior Dimensions	60 $\frac{3}{4}$ "W x 25 $\frac{3}{4}$ "D x 35 $\frac{5}{8}$ "H
Interior Dimensions	48 $\frac{1}{4}$ "W x 18 $\frac{1}{2}$ "D x 28 $\frac{7}{8}$ "H
Net Volume	17.3 cu. ft.
Product Capacity	(2) $\frac{1}{2}$ kegs
Net Weight	276 lb.
Gross Weight	319 lb.
Packaging Dimensions	63 $\frac{1}{2}$ "W x 27 $\frac{1}{2}$ "D x 41 $\frac{3}{4}$ "H

### Cooling

Temperature Range	33 - 40°F
Refrigerant	R290
Max. Ambient Temperature	90°F
Defrosting	Automatic
Temperature Controller	Digital
Horsepower	1/5

### Construction

Exterior Material	Black Coated Steel
Interior Material	Type 304 Stainless Steel
Countertop Type	Type 304 Stainless Steel
Door Type	Glass
Insulation Material	Foamed-in-place polyurethane
Shelf Size	(4) 23 $\frac{5}{8}$ " x 18 $\frac{1}{8}$ "
Shelf Material	Epoxy-coated steel
Shelf Load Capacity	90 lb.

### Electrical

Voltage	115
Amps	2.88
Hz	60
Phase	1
Plug Type	NEMA 5-15P
Electrical Cord Length	106"

## PLAN VIEW

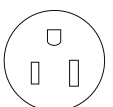
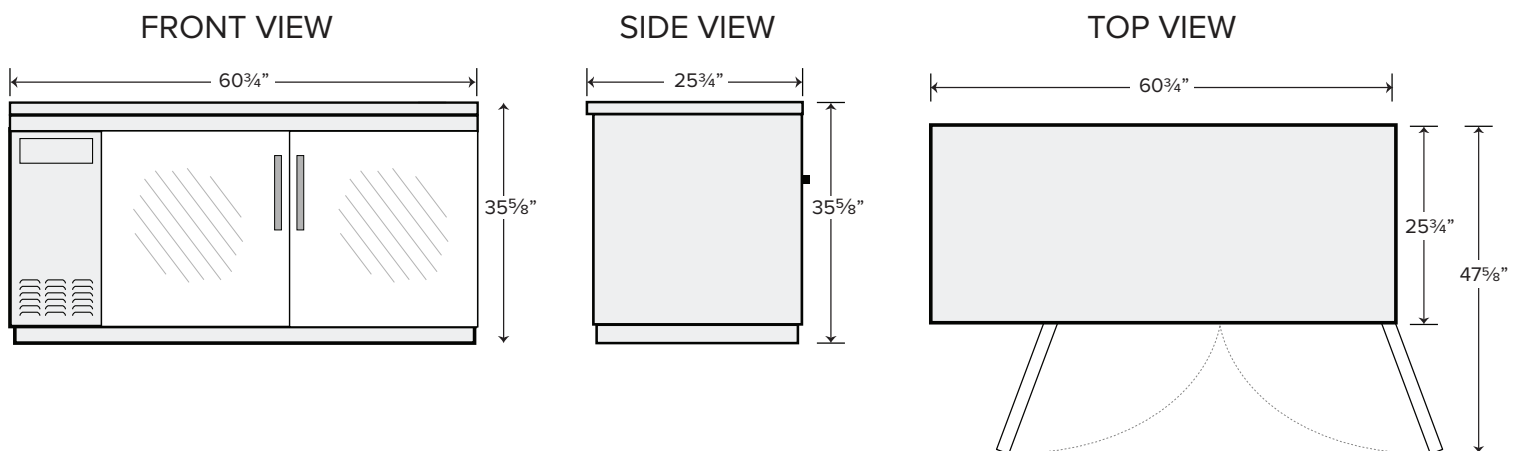

NEMA 5-15P