

# Installation Operation Maintenance

---

## Split System Heat Pump Condensers

*7½ - 20 Tons*

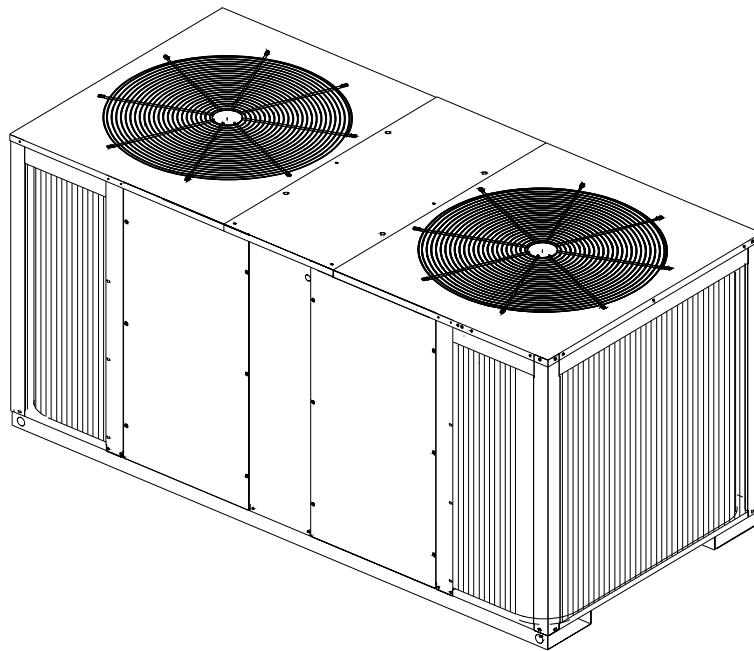

**Model Numbers:**

**(60 Hz)**

TWA090A\*\*\*F

TWA120A\*\*\*F

TWA180B\*\*\*F

TWA240B\*\*\*F

**(50 Hz)**

TWA075AD\*\*F

TWA100AD\*\*F

TWA155BD\*\*F

TWA200BD\*\*F

# Warnings, Cautions and Notices

**Warnings, Cautions and Notices.** Note that warnings, cautions and notices appear at appropriate intervals throughout this manual. Warnings are provide to alert installing contractors to potential hazards that could result in personal injury or death. Cautions are designed to alert personnel to hazardous situations that could result in personal injury, while notices indicate a situation that may result in equipment or property-damage-only accidents.

Your personal safety and the proper operation of this machine depend upon the strict observance of these precautions.

**Important:** *All phases of this installation must comply with the NATIONAL, STATE & LOCAL CODES. In addition to local codes, the installation must conform with National Electric Code —ANSI/NFPA NO. 70 LATEST REVISION.*

**ATTENTION:** Warnings, Cautions and Notices appear at appropriate sections throughout this literature. Read these carefully.

 **WARNING:** Indicates a potentially hazardous situation which, if not avoided, could result in death or serious injury.

 **CAUTION:** Indicates a potentially hazardous situation which, if not avoided, may result in minor or moderate injury. It could also be used to alert against unsafe practices.

**NOTICE:** Indicates a situation that may result in equipment or property-damage only accidents.

## Important Environmental Concerns!

Scientific research has shown that certain man-made chemicals can affect the earth's naturally occurring stratospheric ozone layer when released to the atmosphere. In particular, several of the identified chemicals that may affect the ozone layer are refrigerants that contain Chlorine, Fluorine and Carbon (CFCs) and those containing Hydrogen, Chlorine, Fluorine and Carbon (HCFCs). Not all refrigerants containing these compounds have the same potential impact to the environment. Trane advocates the responsible handling of all refrigerants-including industry replacements for CFCs such as HCFCs and HFCs.

## Responsible Refrigerant Practices!

Trane believes that responsible refrigerant practices are important to the environment, our customers, and the air conditioning industry. All technicians who handle refrigerants must be certified. The Federal Clean Air Act (Section 608) sets forth the requirements for handling, reclaiming, recovering and recycling of certain refrigerants and the equipment that is used in these service procedures. In addition, some states or municipalities may have additional requirements that must also be adhered to for responsible management of refrigerants. Know the applicable laws and follow them.

### **WARNING**

#### **Contains Refrigerant!**

**System contains oil and refrigerant and may be under positive pressure. Recover refrigerant to relieve pressure before opening the system. See unit nameplate for refrigerant type. Do not use non-approved refrigerants, refrigerant substitutes, or refrigerant additives. Failure to follow proper procedures or the use of non-approved refrigerants, refrigerant substitutes, or refrigerant additives could result in death or serious injury or equipment damage.**

**⚠ WARNING****Hazardous Voltage w/Capacitors!**

Disconnect all electric power, including remote disconnects before servicing. Follow proper lockout/tagout procedures to ensure the power cannot be inadvertently energized. For variable frequency drives or other energy storing components provided by Trane or others, refer to the appropriate manufacturer's literature for allowable waiting periods for discharge of capacitors. Verify with an appropriate voltmeter that all capacitors have discharged. Failure to disconnect power and discharge capacitors before servicing could result in death or serious injury.

**NOTICE****Roof Damage!**

System contains oil and refrigerant under high pressure. Roofs should be protected from exposure to oils and refrigerant in the system. If rooftop is not protected damage to the roof may occur.

**Note:** *One copy of this document ships inside the control panel of each unit and is customer property. It must be retained by the unit's maintenance personnel.*

This booklet describes proper installation, operation, and maintenance procedures for air cooled systems. By carefully reviewing the information within this manual and following the instructions, the risk of improper operation and/or component damage will be minimized.

It is important that periodic maintenance be performed to help assure trouble free operation. A maintenance schedule is provided at the end of this manual. Should equipment failure occur, contact a qualified service organization with qualified, experienced HVAC technicians to properly diagnose and repair this equipment.

# Table of Contents

|                                      |    |
|--------------------------------------|----|
| Warnings, Cautions and Notices ..... | 2  |
| Model Number Description .....       | 5  |
| Unit Dimensions .....                | 6  |
| Electrical Data .....                | 9  |
| Installation .....                   | 10 |
| System Pre-Start Procedure .....     | 22 |
| System Start Procedure .....         | 24 |
| Maintenance .....                    | 27 |
| Warranty .....                       | 30 |
| Wiring Diagram Matrix .....          | 33 |

# Model Number Description

|              |              |          |          |            |          |          |
|--------------|--------------|----------|----------|------------|----------|----------|
| <u>T W A</u> | <u>0 9 0</u> | <u>A</u> | <u>1</u> | <u>0 0</u> | <u>E</u> | <u>A</u> |
| 1 2 3        | 4 5 6        | 7        | 8        | 9 10       | 11       | 12       |

## Digits 1,2,3 - Product Type

TWA = Split System Heat Pump Outdoor Unit

## Digits 4,5,6 - Nominal Gross Cooling Capacity (MBh)

090 = 90 MBH, 7 1/2 Tons

120 = 120 MBH, 10 Tons

180 = 180 MBH, 15 Tons

240 = 240 MBH, 20 Tons

## Digit 7 - Major Development Sequence

A = Single Circuit

B = Dual Circuit

## Digits 8 - Electrical Characteristics

3 = 208-230/60/3

4 = 460/60/3

W = 575/60/3

D = 380-415/50/3

## Digits 9,10 - Factory Installed Options

00 = Secondary Capacity and/or Factory Installed Options

0S = Black Epoxy Coated Coil

## Digits 11 - Minor Design Sequence

A = Current Design Sequence

## Digits 12 - Service Digit

A = Current Service Digit

### Notes:

1. All products are identified by a multiple-character model number that precisely identifies a particular type of unit. An explanation of the alphanumeric identification code is provided above. Its use will enable the owner/operator, installing contractors, and service engineers to define the operation, specific components, and other options for any specific unit.
2. When ordering replacement parts or requesting service, be sure to refer to the specific model number, serial number, and DL number (if applicable) stamped on the unit nameplate.



**Figure 3. TWA155B, TWA180B Dimensional Data, Connection Locations, Clearances, Corner Weights**

| MODEL NO.      | APPROXIMATE CORNER WEIGHT (MASS) |         |         |         | TOTAL UNIT WEIGHT | TOTAL SHIPPING WEIGHT |
|----------------|----------------------------------|---------|---------|---------|-------------------|-----------------------|
|                | #1                               | #2      | #3      | #4      |                   |                       |
| TWA155B--D,E,F | 195 lb                           | 186 lb  | 175 lb  | 184 lb  | 740 lb            | 816 lb                |
| TWA180B--D,E,F | 88.5 kg                          | 84.4 kg | 79.5 kg | 83.5 kg | 335.6 kg          | 370.1 kg              |

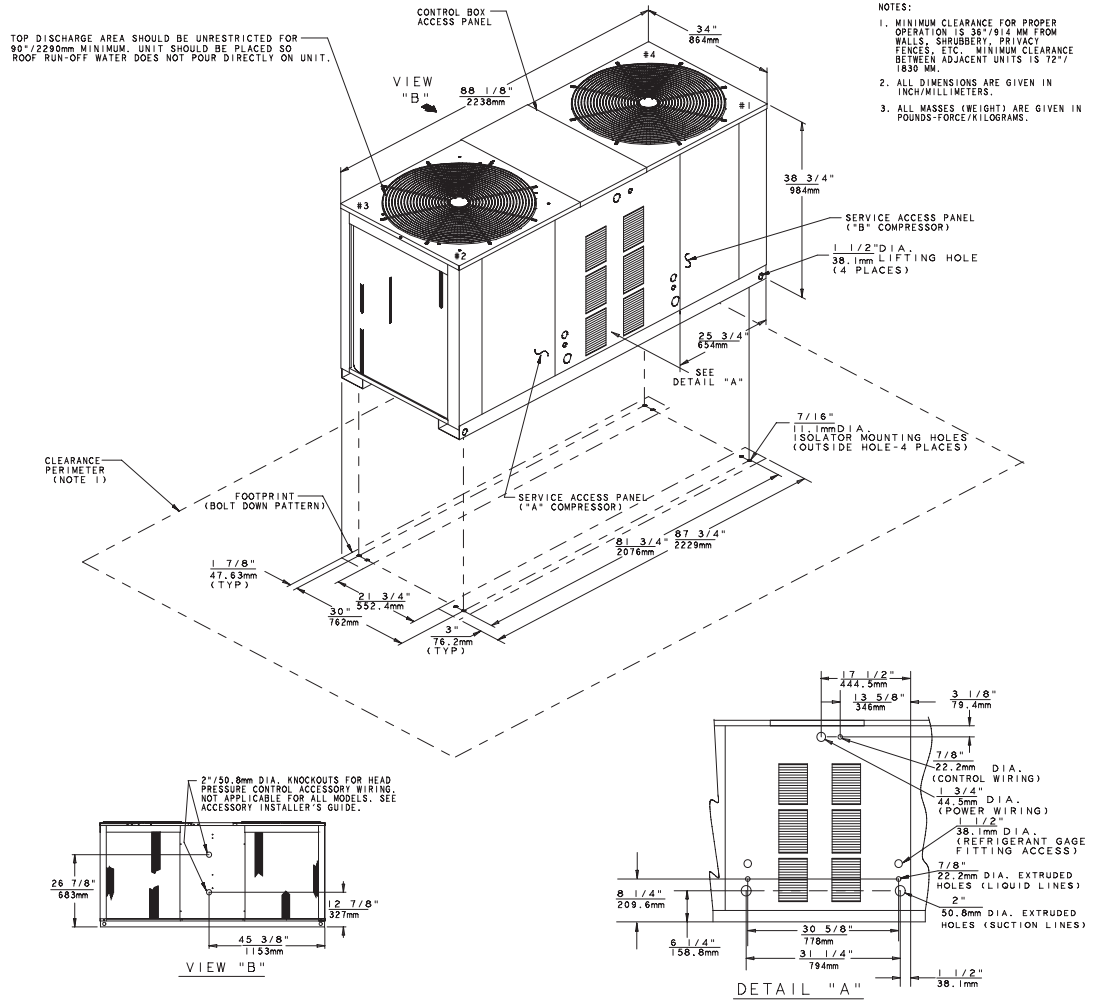

- NOTES:**
1. MINIMUM CLEARANCE FOR PROPER OPERATION IS 38 7/8" INK FROM WALLS, SHRUBBERY, PRIVACY FENCES, ETC. MINIMUM CLEARANCE BETWEEN ADJACENT UNITS IS 12 1/2" 1830 MM.
  2. ALL DIMENSIONS ARE GIVEN IN INCH/MILLIMETERS.
  3. ALL MASSES (WEIGHT) ARE GIVEN IN POUNDS-FORCE/KILOGRAMS.

# Unit Dimensions

**Figure 4. TWA200B, TWA240B Dimensional Data, Connection Locations, Clearances, Corner Weights**

| MODEL NO.   | APPROXIMATE CORNER WEIGHT [MASS] |          |         |         | TOTAL UNIT WEIGHT | TOTAL SHIPPING WEIGHT |
|-------------|----------------------------------|----------|---------|---------|-------------------|-----------------------|
|             | #1                               | #2       | #3      | #4      |                   |                       |
| TWA240B---F | 253 lbs                          | 250 lbs  | 173 lbs | 173 lbs | 849 lb            | 934 lb                |
| TWA200B---F | 114.9 kg                         | 113.5 kg | 78.5 kg | 78.5 kg | 385.1 kg          | 423.7 kg              |

TOP DISCHARGE AREA SHOULD BE UNRESTRICTED FOR 100"/2540 mm MINIMUM. UNIT SHOULD BE PLACED SO ROOF RUN-OFF WATER DOES NOT POUR DIRECTLY ON UNIT.

**NOTES:**

1. MINIMUM CLEARANCE FOR PROPER OPERATION IS 36"/914mm FROM WALLS, SHRUBBERY, PRIVACY FENCES, ETC. MINIMUM CLEARANCE BETWEEN ADJACENT UNITS IS 72"/1830mm.
2. ALL DIMENSIONS ARE GIVEN IN INCH/MILLIMETERS.
3. ALL MASSES (WEIGHT) ARE GIVEN IN POUNDS-FORCE/KILOGRAMS.

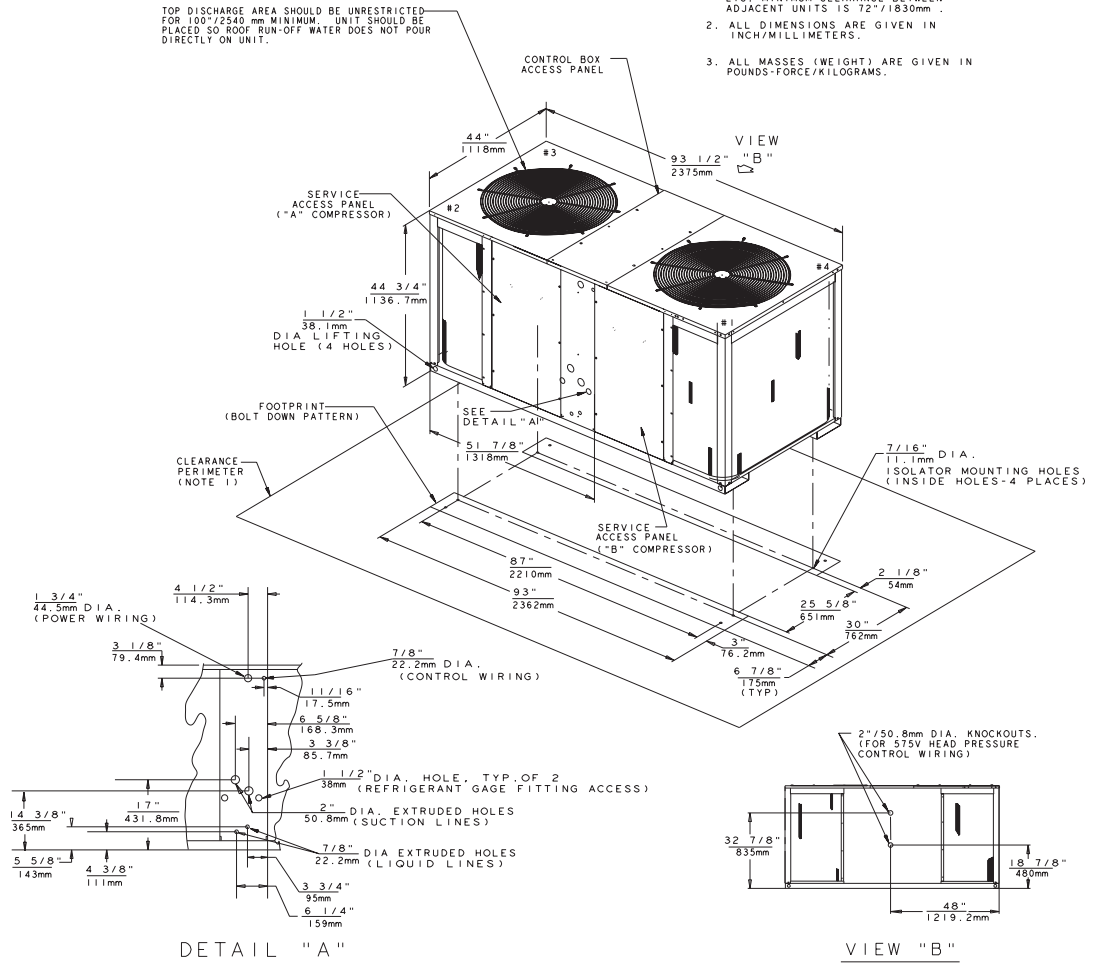

# Electrical Data

Table 1. TWA Unit Electrical Data

| Model Number | Basic Unit Characteristics |                         |                          |                   | Compressor Motor |      |       | Outdoor Fan Motor |     |      |      |
|--------------|----------------------------|-------------------------|--------------------------|-------------------|------------------|------|-------|-------------------|-----|------|------|
|              | Electrical Characteristics | Allowable Voltage Range | Minimum Circuit Ampacity | Maximum Fuse Size | Qty.             | Amps |       | Qty.              | HP  | Amps |      |
|              |                            |                         |                          |                   |                  | RLA  | LRA   |                   |     | FLA  | LRA  |
| TWA090A3     | 208-230/60/3               | 187-254                 | 34.5                     | 50                | 1                | 25.1 | 182.0 | 1                 | 1/2 | 3.1  | 8.1  |
| TWA090A4     | 460/60/3                   | 414-506                 | 18.1                     | 25                | 1                | 13.2 | 94.9  | 1                 | 1/2 | 1.6  | 3.7  |
| TWA090AW     | 575/60/3                   | 518-632                 | 14.5                     | 20                | 1                | 10.6 | 70.0  | 1                 | 1/2 | 1.2  | 3.0  |
| TWA075AD     | 380-415/50/3               | 380-415                 | 12.6                     | 20                | 1                | 8.8  | 90.0  | 1                 | 1/2 | 1.6  | 3.7  |
| TWA120A3     | 208-230/60/3               | 187-254                 | 48.1                     | 70                | 1                | 33.7 | 278.0 | 1                 | 1   | 6.0  | 17.5 |
| TWA120A4     | 460/60/3                   | 414-506                 | 23.3                     | 35                | 1                | 16.5 | 124.0 | 1                 | 1   | 2.7  | 7.0  |
| TWA120AW     | 575/60/3                   | 518-632                 | 18.8                     | 25                | 1                | 13.4 | 92.0  | 1                 | 1   | 2.0  | 5.7  |
| TWA100AD     | 380-415/50/3               | 380-415                 | 22.5                     | 35                | 1                | 15.8 | 124.0 | 1                 | 1   | 2.7  | 7.0  |
| TWA180B3     | 208-230/60/3               | 187-254                 | 62.7                     | 80                | 2                | 25.1 | 182.0 | 2                 | 1/2 | 3.1  | 8.1  |
| TWA180B4     | 460/60/3                   | 414-506                 | 32.9                     | 45                | 2                | 13.2 | 94.9  | 2                 | 1/2 | 1.6  | 3.7  |
| TWA180BW     | 575/60/3                   | 518-632                 | 26.3                     | 35                | 2                | 10.6 | 70.0  | 2                 | 1/2 | 1.2  | 3.0  |
| TWA155BD     | 380-415/50/3               | 380-415                 | 28.4                     | 35                | 2                | 11.2 | 94.9  | 2                 | 1/2 | 1.6  | 3.7  |
| TWA240B3     | 208-230/60/3               | 187-254                 | 87.8                     | 100               | 2                | 33.7 | 278.0 | 2                 | 1   | 6.0  | 17.5 |
| TWA240B4     | 460/60/3                   | 414-506                 | 42.5                     | 50                | 2                | 16.5 | 118.0 | 2                 | 1   | 2.7  | 7.0  |
| TWA240BW     | 575/60/3                   | 518-632                 | 34.2                     | 45                | 2                | 13.4 | 92.0  | 2                 | 1   | 2.0  | 5.7  |
| TWA200BD     | 380-415/50/3               | 380-415                 | 41.0                     | 50                | 2                | 15.8 | 124.0 | 2                 | 1   | 2.7  | 7.0  |

# Installation

Installation procedures should be performed in the sequence that they appear in this manual. Do not destroy or remove the manual from the unit. The manual should remain weather-protected with the unit until all installation procedures are complete.

**Note:** *It is not the intention of this manual to cover all possible variations in systems that may occur or to provide comprehensive information concerning every possible contingency that may be encountered during an installation. If additional information is required or if specific problems arise that are not fully discussed in this manual, contact your local Sales office.*

**Note:** *“Warnings” and “Cautions” appear at appropriate places in this manual. Your personal safety and the proper operation of this machine require that you follow them carefully. The Company assumes no liability for installations or servicing performed by unqualified personnel.*

## Installation Checklist

An “Installation Checklist” is provided at the end of the installation section of this manual. Use the checklist to verify that all necessary installation procedures have been completed. Do not use the checklist as a substitute for reading the information contained in the manual. Read the entire manual before beginning installation procedures.

## Unit Inspection

Inspect material carefully for any shipping damage. If damaged, it must be reported to, and claims made against the transportation company. Compare the information that appears on the unit nameplate with ordering and submittal data to insure the proper unit was shipped. Available power supply must be compatible with electrical characteristics specified on component nameplates. Replace damaged parts with authorized parts only.

## Inspection Checklist

To protect against loss due to damage incurred in transit, complete the following checklist upon receipt of the unit.

- Inspect individual pieces of the shipment before accepting the unit. Check for obvious damage to the unit or packing material.
- Inspect the unit for concealed damage before it is stored and as soon as possible after delivery. Concealed damage must be reported within 15 days. If concealed damage is discovered, stop unpacking the shipment. Do not remove damaged material from the receiving location. Take photos of the damage if possible. The owner must provide reasonable evidence that the damage did not occur after delivery.
- Notify the carrier’s terminal of damage immediately by phone and by mail. Request an immediate joint inspection of the damage by the carrier and the consignee.
- Notify the sales representative and arrange for repair. Do not repair the unit until the damage is inspected by the carrier’s representative.

## Initial Leak Test

All TWA units are shipped with a holding charge of nitrogen in each circuit. Remove the compressor access panel(s) shown in [Figure 1, p. 6](#), [Figure 2, p. 6](#) or [Figure 3, p. 7](#), [Figure 4, p. 8](#). Locate the liquid line or suction line service valve for each circuit. Install gauges to determine if the circuits are still pressurized. If not, the charge has escaped. Repair as required to obtain a leak-free circuit.

## Lifting Recommendations

Before preparing the unit for lifting, estimate the approximate center of gravity for lifting safety. Because of placement of internal components, the unit weight may be unevenly distributed. Approximate unit weights are given in [Table 2](#).

**Table 2. Total Unit Weight and Corner Weights (lbs)**

| Model Number       | Shipping Maximum | Net Maximum | Corner Weights |     |     |     |
|--------------------|------------------|-------------|----------------|-----|-----|-----|
|                    |                  |             | #1             | #2  | #3  | #4  |
| TWA090A<br>TWA075A | 390              | 343         | 112            | 89  | 63  | 79  |
| TWA120A<br>TWA100A | 502              | 443         | 149            | 116 | 78  | 100 |
| TWA180B<br>TWA155B | 816              | 740         | 195            | 186 | 175 | 184 |
| TWA240B<br>TWA200B | 934              | 849         | 253            | 250 | 173 | 173 |

**⚠️ WARNING**  
**Improper Unit Lift!**

Test lift unit approximately 24 inches to verify proper center of gravity lift point. To avoid dropping of unit, reposition lifting point if unit is not level. Failure to properly lift unit could result in death or serious injury or possible equipment or property-only damage.

**NOTICE**  
**Equipment Damage!**

Do not use a fork lift on air handlers or subassemblies larger than size 30. Improper use of fork lifts on units larger than size 30 may result in equipment damage. Trane is not responsible for equipment damage resulting from improper forklifting practices.

**⚠️ WARNING**  
**Heavy Objects!**

Do not use cables (chains or slings) except as shown. Each of the cables (chains or slings) used to lift the unit must be capable of supporting the entire weight of the unit. Lifting cables (chains or slings) may not be of the same length. Adjust as necessary for even unit lift. Other lifting arrangements may cause equipment or property-only damage. Failure to properly lift unit could result in death or serious injury. See details below.

**NOTICE**  
**Equipment Damage!**

Use spreader bars to prevent lifting straps from damaging the unit. Install bars between lifting straps. This will prevent the straps from crushing the unit cabinet or damaging the unit finish.

The crated unit can be moved using a forklift of suitable capacity. For lifting the unit, attach lifting straps or slings securely to the lifting holes at each corner. Use spreader bars to protect the unit casing from damage. Test lift the unit to determine proper balance and stability.

**Clearances**

Provide enough space around the unit to allow unrestricted access to all service points. Refer to [Figure 1, p. 6](#), [Figure 2, p. 6](#), [Figure 3, p. 7](#) or [Figure 4, p. 8](#) for unit dimensions and minimum required service and free air clearances. Observe the following points to insure proper unit operation:

1. Do not install the unit under a low overhang. Condenser discharge must not be restricted. See [Figure 1](#), [Figure 2](#), [Figure 3](#) or [Figure 4](#).

## Installation

**Important:** Do not obstruct condenser discharge air. This can result in warm air recirculation through the coil.

2. Do not locate the unit in a position where runoff water can fall into the fan discharge openings.
3. Condenser intake air is supplied from three sides of the unit. Adhere to the minimum required clearances given in [Figure 1, p. 6](#), [Figure 2, p. 6](#), [Figure 3, p. 7](#) or [Figure 4, p. 8](#).

## Snow Belt Recommendations

In regions where deep snow is encountered, raise the unit a minimum distance of 8 to 12 inches above the mounting surface. This will reduce the risk of snow blocking the coil and improves runoff of water produced during the defrost cycle. Avoid locating the unit where snow tends to drift. Snow accumulations must be removed from around the unit immediately to prevent drastic efficiency reduction. A snow drift barrier may be constructed around the unit to prevent snow blockage. Clearance between the snow barrier and the unit must comply with the clearances given in [Figure 1, Figure 2 or Figure 3 or Figure 4](#).

## Unit Mounting

### Rooftop Mounting

If the unit will be roof mounted, determine for certain that the structure is strong enough to support the unit and any required accessories. Unit weights are given in Table 2.

The unit should be elevated on a level, field fabricated four-inch steel or wood 4" x 4" mounting frame. Complete the frame and secure it into position before lifting the unit to the roof. The mounting frame must support a minimum of three of the unit's four sides and should span roof supports to distribute the load on the roof.

**Figure 5. Roof Mounted Unit**

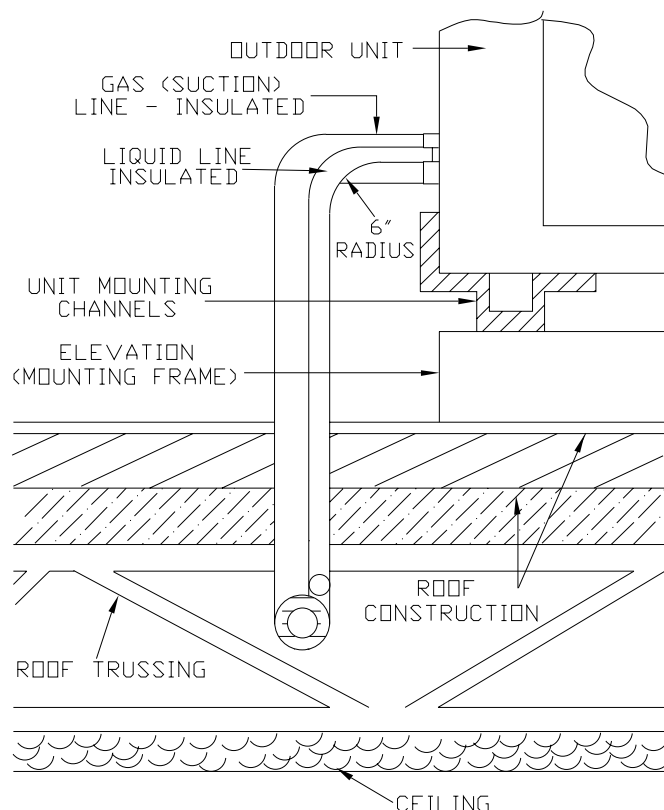

### **WARNING!** **Heavy Objects!**

Ensure that the roof structure supports are strong enough to support the weight of the unit and any accessories. Failure to follow these instruction could result in death, or serious injury and or property damage or equipment damage.

The following warning complies with State of California law, Proposition 65:

### **WARNING!** **Fiberglass Wool!**

Product contains fiberglass wool. Disturbing the insulation in this product during installation, maintenance or repair will expose you to airborne particles of glass wool fibers and ceramic fibers known to the state of California to cause cancer through inhalation. Glass wool fibers could result in respiratory, skin or eye irritation.

## Ground Level Mounting

“For ground level installation, the unit base should be adequately supported and hold the unit near level. The installation must meet the guidelines set forth in local codes.” The support should extend two inches beyond the unit base channels at all points. The unit and support must be isolated from any adjacent structure to prevent possible noise or vibration problems. Any ground level location must comply with required clearances given in [Figure 1, p. 6](#), [Figure 2, p. 6](#), [Figure 3, p. 7](#) or [Figure 4, p. 8](#).

## Refrigerant Piping

### **WARNING** **Contains Refrigerant!**

System contains oil and refrigerant and may be under positive pressure. Recover refrigerant to relieve pressure before opening the system. See unit nameplate for refrigerant type. Do not use non-approved refrigerants, refrigerant substitutes, or refrigerant additives. Failure to follow proper procedures or the use of non-approved refrigerants, refrigerant substitutes, or refrigerant additives could result in death or serious injury or equipment damage.

### **WARNING** **Refrigerant Vapor Hazard!**

All fluorocarbon refrigerant vapors are heavier than air. Vapors may collect and concentrate in confined spaces or low lying areas which will result in the displacement of air. This poses a potential health risk due to suffocation. Provide adequate ventilation to the work area to avoid over-exposure of fluorocarbon refrigerants. Refer to the appropriate MSDS sheets and OSHA guidelines for information referring to allowable personal exposure levels and handling guidelines. Failure to follow proper handling guidelines could result in death or serious injury.

## Structural Preparation

Holes must be made in the structure to run refrigerant lines. For the majority of ground-level installations, the holes can be made in the header that rests on top of the foundation. Alternatively, these holes may also be made in the foundation itself. On roof-mounted units, refrigerant lines should enter the building as close to the unit as possible; preferably within three to four inches of the refrigerant connection on the unit, plus a six-inch (long radius) 90 degree ell entering the building. (See [Figure 5, p. 12](#))

## Refrigerant Piping Guidelines

1. Maximum recommended line lengths: (per circuit)

## Installation

- a. Maximum linear length = 80 Ft. (w/o accumulator)
  - b. Maximum suction line lift = 60 Ft.
  - c. Maximum liquid line lift = 60 Ft.
2. Maximum allowable pressure drops (R-22):
    - a. Suction line = 6 psi
    - b. Liquid line (without subcooler) = 35 psi

Route refrigerant piping for minimum linear length, minimum number of bends and fittings (no reducers) and minimum amount of line exposed to outdoor ambients.

3. Recommended line sizes:
  - a. Suction line - 1 3/8 inch sealed type L refrigerant tubing.
  - b. Liquid line - 1/2 inch sealed type L refrigerant tubing.

**Note:** Insulate all refrigerant piping and connections.

### Refrigerant Piping Procedures (Outdoor Units)

Each TWA unit ships with a holding charge of dry nitrogen. The nitrogen should be removed and the entire system evacuated (at the proper time) to avoid possible contamination.

1. Remove the compressor service access panel.
2. Locate the liquid and suction line service valves. Check that the piping connection stubs on the valves ([Figure 6](#)) line up properly with the holes in the unit cabinet.

**Figure 6.**

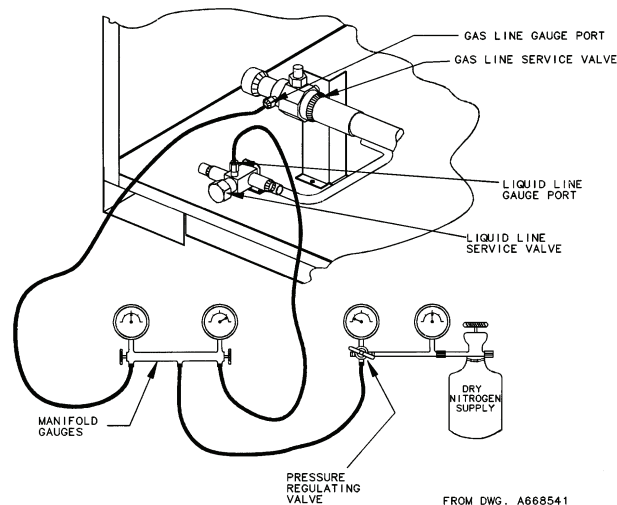

3. Remove the refrigerant connection seal caps and open the service valve slowly to release the nitrogen from the unit.

### **NOTICE**

#### **System Component Damage!**

**Do not remove the seal caps from refrigerant connections until prepared to braze refrigerant lines to the connections. Excessive exposure to atmosphere may allow moisture or dirt to contaminate the system, damaging valve seals and causing ice formation in system components.**

**⚠ WARNING**

**Hazard of Explosion and Deadly Gases!**

Never solder, braze or weld on refrigerant lines or any unit components that are above atmospheric pressure or where refrigerant may be present. Always remove refrigerant by following the guidelines established by the EPA Federal Clean Air Act or other state or local codes as appropriate. After refrigerant removal, use dry nitrogen to bring system back to atmospheric pressure before opening system for repairs. Mixtures of refrigerants and air under pressure may become combustible in the presence of an ignition source leading to an explosion. Excessive heat from soldering, brazing or welding with refrigerant vapors present can form highly toxic gases and extremely corrosive acids. Failure to follow all proper safe refrigerant handling practices could result in death or serious injury.

- Cut, fit and braze tubing, starting at the outdoor unit and work toward the indoor unit.

**Note:** Use long radius ells for all 90° bends.

All brazing should be done using a 2 to 8 psig dry nitrogen purge flowing through the pipe being brazed (Figure 5).

**NOTICE**

**System Component Damage!**

Install a regulating valve between the nitrogen source and the gauge manifold (Figure 6). Unregulated pressure can damage system components.

**NOTICE**

**Valve Damage!**

Disassemble the thermal expansion valve before completing the brazing connections. If necessary, wrap the valve in a cool, wet cloth while brazing. Failure to protect the valve from high temperatures may result in damage to internal components.

- Shut off nitrogen supply.
- Shut off the manifold valve for the line that is connected to the suction line service valve. Disconnect the line from the gauge port on the valve.

Figure 7.

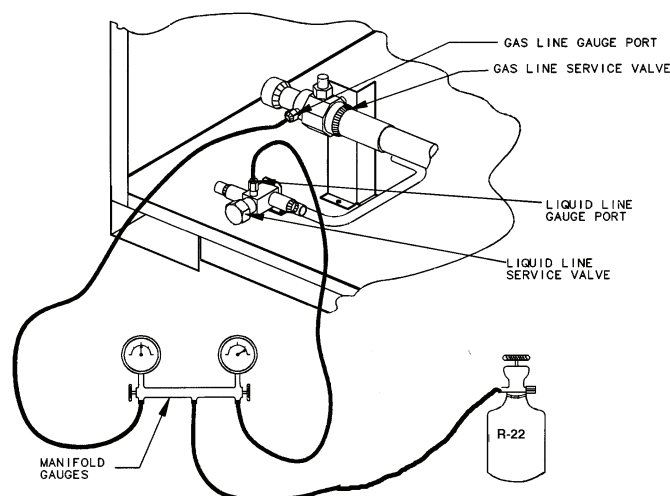

### Refrigerant Piping Procedure (Indoor Unit)

Once liquid and suction lines are complete to the refrigerant connections on the indoor unit, puncture the seal caps on the indoor unit connection stubs to release the dry nitrogen charge.

#### **NOTICE**

#### **Equipment Damage!**

**Do not apply heat to remove seal caps until they have been punctured. If seal caps are intact, application of heat may generate excessive pressure in the unit and result in damage to the coil or expansion valve.**

1. Remove both seal caps from the indoor unit connection stubs.

#### **NOTICE**

#### **Equipment Damage!**

**Do not remove seal caps until prepared to braze refrigerant lines to the connections. Extended exposure to atmosphere may allow moisture or dirt to contaminate the system, damaging valve seats and causing ice formation in system components.**

#### **WARNING**

#### **Hazard of Explosion and Deadly Gases!**

**Never solder, braze or weld on refrigerant lines or any unit components that are above atmospheric pressure or where refrigerant may be present. Always remove refrigerant by following the guidelines established by the EPA Federal Clean Air Act or other state or local codes as appropriate. After refrigerant removal, use dry nitrogen to bring system back to atmospheric pressure before opening system for repairs. Mixtures of refrigerants and air under pressure may become combustible in the presence of an ignition source leading to an explosion. Excessive heat from soldering, brazing or welding with refrigerant vapors present can form highly toxic gases and extremely corrosive acids. Failure to follow all proper safe refrigerant handling practices could result in death or serious injury.**

2. Turn nitrogen supply on. Nitrogen enters thorough liquid line gauge port.
3. Braze the liquid line connections.
4. Open the gauge port on the suction line and then braze the suction line to the connection stub. Nitrogen will bleed out the open gauge port on the suction line.
5. Shut off nitrogen supply.

#### **Leak Check**

After the brazing operation of refrigerant lines to both the outdoor and indoor unit is completed, the field brazed connections must be checked for leaks. Pressurize the system through the service valve with dry nitrogen to 200 psi. Use soap bubbles or other leak-checking methods to ensure that all field joints are leak free. If not, release pressure, repair and repeat leak test.

#### **System Evacuation**

1. After completion of leak check, evacuate the system.
2. Attach appropriate hoses from manifold gauge to gas and liquid line pressure taps.

**Note:** *Unnecessary switching of hoses can be avoided and complete evacuation of all lines leading to sealed system can be accomplished with manifold center hose and connecting branch hose to a cylinder of R-22 and vacuum pump.*

3. Attach center hose of manifold gauges to vacuum pump.
4. Evacuate the system to hold a 350 micron vacuum.

5. Close off valve to vacuum pump and observe the micron gauge. If gauge pressure rises above 500 microns in one (1) minute, then evacuation is incomplete or the system has a leak.
6. If vacuum gauge does not rise above 500 microns in one (1) minute, the evacuation should be complete.
7. With vacuum pump and micron gauge blanked off, open valve on R-22 cylinder and allow refrigerant pressure to build up to about 40 psig.
8. Close valve on the R-22 supply cylinder. Close valves on manifold gauge set and remove refrigerant charging hoses from liquid and gas gauge ports.
9. Leak test the entire system. Using proper procedures and caution, repair any leaks found and repeat the leak test.

### Refrigerant Charging Procedure

If charging by weight, refer to refrigerant charges that are given in Table 3. If additional refrigerant is needed because of length of line, calculate the requirement using Table 4. Charge by weight through the gauge port on the liquid line. Once the charge enters the system, backseat (open) the liquid line service valve and disconnect the charging line and replace the cap on the gauge port.

### Insulating and Isolating Refrigerant Lines

Insulate the entire suction line with refrigerant piping insulation. Also insulate any portion of the liquid line exposed to temperature extremes. Insulate and isolate liquid and suction lines from each other. Isolate refrigerant lines from the structure and any duct work.

**Note:** To prevent possible noise or vibration problems, be certain to isolate refrigerant lines from the building.

**Table 3. TWA Refrigerant Charge (R-22)<sup>(a)</sup>**

| Model Number | Refrigerant Charge             |
|--------------|--------------------------------|
| TWA090A      | 18 lbs. 0.0 oza.               |
| TWA075A      |                                |
| TWA120A      | 31 lbs. 8.0 ozs.               |
| TWA100A      |                                |
| TWA180B      | 18 lbs. 0.0 ozs. (per circuit) |
| TWA155B      |                                |
| TWA240B      | 22 lbs. 4.0 ozs. (per circuit) |
| TWA200B      |                                |

(a) Sufficient operating charge for outdoor unit and 25 feet of nominally sized refrigerant piping.

**Table 4. Additional Required Refrigerant<sup>(a)(b)</sup>**

| Additional Tubing Length | Additional R-22 Required (lbs.) |
|--------------------------|---------------------------------|
| 15 ft.                   | 1 lb. 4 oz.                     |
| 25 ft.                   | 2 lbs. 1 oz.                    |
| 32 ft.                   | 2 lbs. 11 oz.                   |
| 40 ft.                   | 3 lbs. 5 oz.                    |

(a) Based on 1-3/8" dia. Suction line, 1/2" liquid line.

(b) Add .5 lbs. R-22 for each additional six feet of tubing length over 40 feet.

**Note:** For tubing over 40 ft. calculate the additional refrigerant needed, based on notes above.

### Gaseous Charging

This procedure is accomplished with the unit operating. Electrical connections must be complete. Do not proceed until the system is ready to operate.

#### Procedure

1. Connect R-22 drum with gauge manifold to the Schrader valves (pressure taps) on the compressor discharge and suction lines (Figure 6).

**Note:** *The compressor access panel must be installed when the unit is running and being charged. The control box access panel must be removed, and the manifold hoses must be routed through an opening located in the bottom front of the control box. The opening has a pivoted cover plate.*

### WARNING

#### Live Electrical Components!

**During installation, testing, servicing and troubleshooting of this product, it may be necessary to work with live electrical components. Have a qualified licensed electrician or other individual who has been properly trained in handling live electrical components perform these tasks. Failure to follow all electrical safety precautions when exposed to live electrical components could result in death or serious injury.**

2. Turn on power to the unit. Allow the system to run for five to ten minutes to stabilize operating conditions.
3. Measure airflow across the indoor coil. Compare the measurements with the fan performance data in the Data/Submittal or Service Facts. Once proper airflow is established, observe the suction and head pressure gauges on the gauge manifold. Pressure reading should fall approximately at the points shown by the pressure curves in Service Facts. Add or remove refrigerant (gas only) as required to obtain correct head and suction pressures. Check suction line superheat and condenser subcooling to ensure the unit is operating properly.

### WARNING

#### Hazardous Voltage w/Capacitors!

**Disconnect all electric power, including remote disconnects and discharge all motor start/run capacitors before servicing. Follow proper lockout/tagout procedures to ensure the power cannot be inadvertently energized. For variable frequency drives or other energy storing components provided by Trane or others, refer to the appropriate manufacturer's literature for allowable waiting periods for discharge of capacitors. Verify with an appropriate voltmeter that all capacitors have discharged. Failure to disconnect power and discharge capacitors before servicing could result in death or serious injury.**

4. Disconnect all power to the unit.
5. Remove the charging system from the unit and close the opening in the bottom of the control box with the pivotal cover before attempting to replace access panel.
6. Replace all panels.

### Electrical Wiring

TWA field wiring consists of providing power supply to the unit, installing the system indoor thermostat and providing low voltage system interconnecting wiring. Access to electrical connection locations is shown in [Figure 1, p. 6](#), [Figure 2, p. 6](#) and [Figure 4, p. 8](#).

**⚠ WARNING**

**Grounding Required!**

Follow proper local and state electrical code on requirements for grounding. Failure to follow code could result in death or serious injury.

**Unit Power Supply**

The installer must provide line voltage circuit(s) to the unit main power terminals as shown by the unit wiring diagrams in Service Facts or field wiring. Power supply must include a disconnect switch in a location convenient to the unit. Ground the unit according to local codes and provide flexible conduit if codes require and/or if vibration transmission may cause noise problems.

**Important:** All wiring must comply with applicable local and national (NEC) codes. Type and location of disconnect switches must comply with all applicable codes.

**NOTICE**

**Use Copper Conductors Only!**

Unit terminals are not designed to accept other types of conductors. Failure to use copper conductors may result in equipment damage.

**⚠ WARNING**

**Hazardous Voltage w/Capacitors!**

Disconnect all electric power, including remote disconnects and discharge all motor start/run capacitors before servicing. Follow proper lockout/tagout procedures to ensure the power cannot be inadvertently energized. Verify with an appropriate voltmeter that all capacitors have discharged. Failure to disconnect power and discharge capacitors before servicing could result in death or serious injury.

Determine proper wire sizes and unit protective fusing requirements by referring to the unit nameplate and/or the unit Service Facts. Field wiring diagrams for accessories are shipped with the accessory.

**Low Voltage Wiring**

Mount the indoor thermostat in accordance with the thermostat installation instructions. Install color-coded, weather-proof, multi-wire cable according to the Interconnecting Wiring diagrams in the Air Handler IOM.

# Installation

## Typical Field Wiring

Figure 8. Typical Split System Heat Pump Refrigerant Circuits

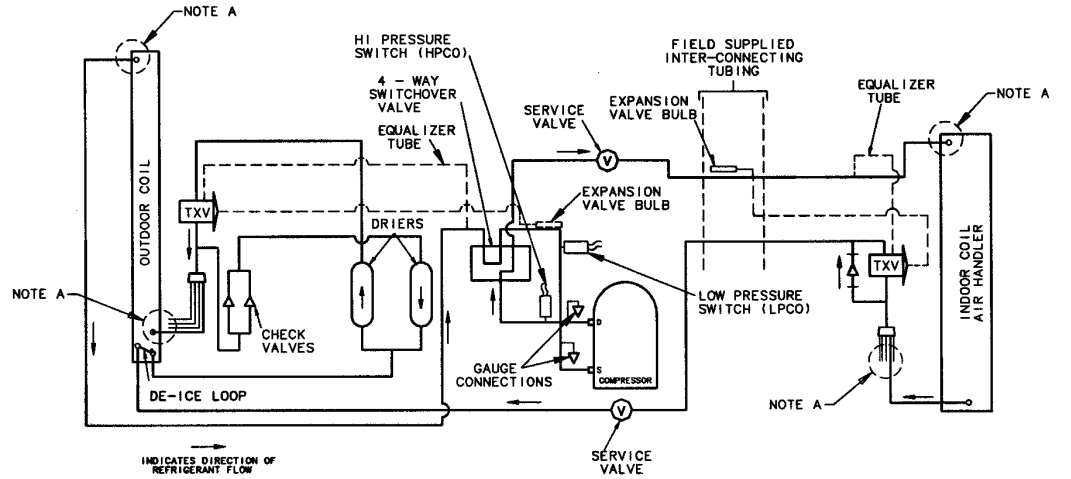

HEATING MODE

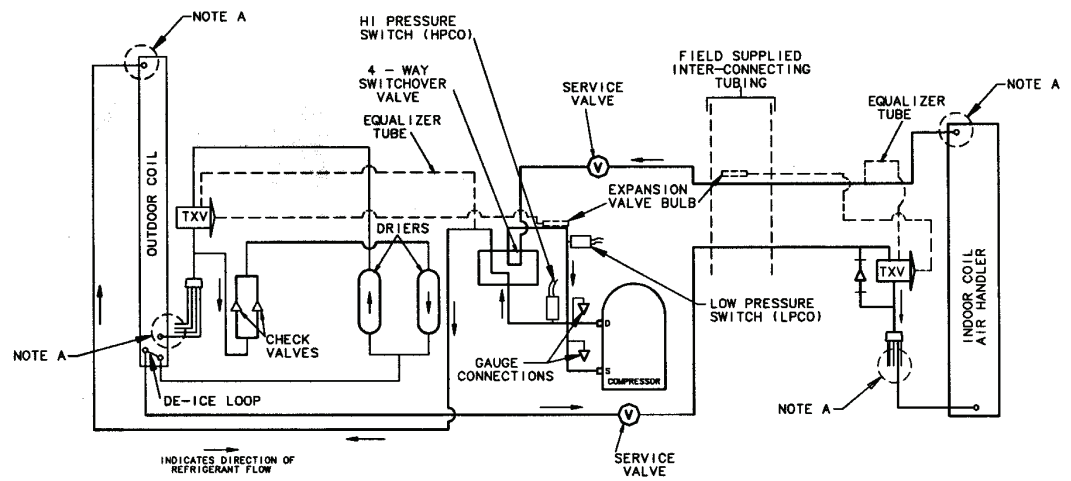

COOLING MODE

NOTE A: ONLY ONE INDOOR & OUTDOOR COIL ENTRY/EXIT CIRCUIT IS SHOWN; ALL MODELS HAVE MULTIPLE ENTRY/EXIT CIRCUITS.

**Figure 9. Typical Field Wiring**

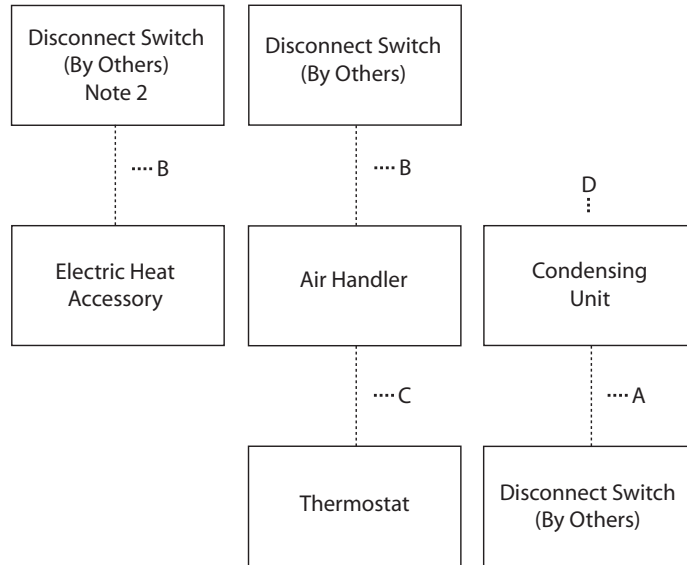

**Notes:**

1. Wiring shown with dashed lines is to be furnished and installed by the customer. All customer-supplied wiring must be copper only and must conform to NEC and local electrical codes. Codes may require line of sight between disconnect switch and unit.
2. When electric heater accessory is used

**⚠ WARNING**  
**Hazardous Voltage**

**Disconnect all electric power, including remote disconnects before servicing. Follow proper lockout/tagout procedures to ensure the power can not be inadvertently energized. Failure to disconnect power before servicing could result in death or serious injury.**

**NOTICE**  
**Use Copper Conductors Only!**

**Unit terminals are not designed to accept other types of conductors. Failure to use copper conductors could result in equipment damage.**

**TWA090 & 075A/TWE090 & 075A**  
**TWA120 & 100A/TWE120 & 100A**

**Field Wiring:**

- A – 3 power wires, line voltage
- B – 3 power wires, line voltage for 3 phase; 2 wires for single phase
- C – Heat pump thermostat: 6 wires, 24 volts; Electric heat: Add 2 additional wires, 24 volts
- D – 6 wires, 24 volts; Outdoor thermostat: add 1 additional wire, 24 volts; Electric heat: Add 1 additional wire, 24 volts

# System Pre-Start Procedure

## Safety Controls

**Note:** All of these controls may not be installed on your unit, check electrical schematic.

## Evaporator Defrost Control (EDC)

This control is located in the Air Handler of Split Units. The control's sensing tube is imbedded vertically in the evaporator coil, near the center. This device will stop the compressor if the coil temperature drops below its setting. The indoor air will still circulate across the coil, bringing the temperature of the coil back up to the cut-in temperature of the evaporator defrost control.

## Low Pressure Cut-Out (LPCO)

This control's sensor is located in the suction (gas) line, near the compressor. The control will stop the compressor and outdoor fans if suction pressure drops below the Low Pressure Cut-Out setting. Once the suction pressure has returned to normal, the compressor and outdoor fans will cycle back on.

## High Pressure Cut-Out (HPCO)

This control's sensor is located in the discharge line. This device will shut off the compressor and the outdoor fan(s) if the discharge pressure exceeds the High Pressure Cut-Out setting. Once the discharge pressure has returned to normal, the compressor will cycle back on.

## Internal Overload Protector (IOL)

This device is a current/thermal actuated warp switch, imbedded in the compressor motor windings. It will shut off the compressor if the temperature or current of the compressor motor windings exceeds its design trip temperature.

**Note:** The IOL will put the compressor back in operation once the compressor motor heat has dropped below the trip setting; however, a check of the refrigerant and electrical system should be made to determine the cause and be corrected.

### Installation Checklist

Complete this checklist once the unit is installed to verify that all recommended procedures have been accomplished before starting the system. Do not operate the system until all items covered by this checklist are complete.

7. Inspect unit location for proper required service clearances.
8. Inspect unit location for proper free air clearances.
9. Inspect unit location for secure, level mounting position.

### Refrigerant Piping

1. Performed initial leak test?
2. Connected properly sized and constructed liquid and suction lines to the connection stubs at both the indoor and outdoor units?
3. Insulated the entire suction line?
4. Insulated portions of liquid line exposed to extremes in temperature?
5. Evacuated each refrigerant circuit to 350 microns?
6. Charged each circuit with proper amount of R-22?

### Electrical Wiring

1. Provided unit power wiring (with disconnect) to proper terminals in the unit control section?
2. Installed system indoor thermostat?
3. Installed system low voltage interconnecting wiring to proper terminals of outdoor unit, indoor unit and system thermostat?

# System Start Procedure

## Sequence of Operation

### Unit Start-Up

Once the unit is properly installed and pre-start procedures are complete, start the unit by turning the System Switch on the indoor thermostat to either HEAT, COOL or AUTO. The system should operate normally.

### **NOTICE**

### **Compressor Damage!**

**Ensure the disconnect for the indoor air handler is closed before operating the system. Operating the indoor unit without the indoor fan energized, can cause unit trip-out on high pressure control and/or liquid flood back to the compressor.**

### General

Operation of the unit is controlled by the HEAT and/or COOL setting in the thermostat. (An optional automatic changeover thermostat, when in the AUTO position, automatically changes to heat or cool cycles with sufficient room temperature change.) The fan switch can be placed in either the ON position, causing continuous indoor fan operation, or the AUTO position causing fan operation to coincide with heating or cooling run cycles. With the disconnect switch in the closed position, current is supplied to the compressor crankcase heater(s) and the control transformer. The outdoor fan relay (ODF) is energized through a continuous 24 volt circuit from the transformer, and controlled through normally closed contacts on the defrost control board (DFC).

### Cooling Mode

With the system switch on the thermostat set to COOL, current is supplied from the "R" terminal to the "O" terminal on the low voltage terminal board of the outdoor unit. This energizes the switch-over valve (SOV) and places it in the cooling position.

The evaporator defrost relay (EDR) is also energized at this time, opening EDR-1 contacts to allow the evaporator defrost control (EDC) to function while in the cooling mode, and opening EDR-2 contacts to prevent defrost control (DFC) operation while in cooling mode.

When the room temperature is 1½ degrees above the thermostat setting, a cooling cycle is initiated by closing of the TSC-1 contacts in the thermostat.

When closed, these contacts supply power from "R" terminal through TSC-1 to "Y" terminal on the low voltage terminal board of the outdoor unit, which supplies power to the (CC) compressor contactor, (compressor auxiliary relay (CCA) or auxiliary compressor contactor (ACCA) on specific models.

This closes the compressor contacts, which starts the compressor and outdoor fan motor. TSC-1 contacts also supply power to the "G" terminal in the thermostat, which energizes the fan relay (F), starting the indoor fan motor (provided the fan switch is in the AUTO position).

On dual circuit units, when second stage cooling is required, "Y2" terminal from the thermostat energizes auxiliary compressor contactor (ACC) which energizes compressor contactor B (CC-B), (ACCB on some models) provided the HPCO and LPCO are closed.

An "O" signal for cooling is supplied to the defrost control board (DFC-B) through the evaporator defrost relay (EDR) which was previous energized. This signal causes an output to the switch-over valve (SOV-B), placing it in the cooling mode.

### Heating Mode

With the system switch on the thermostat set to the HEAT position, and the room temperature drops approximately 1 ½ degrees below the thermostat setting, a heating cycle is initiated by closing of the TSH-1 contacts.

When closed, these contacts supply power from "R" terminal through TSH-1 to "Y" terminal on the low voltage terminal board of the outdoor unit, which supplies power to the (CC) compressor contactor, (compressor auxiliary relay (CCA) or auxiliary compressor contactor (ACCA) on specific models).

This closes the compressor contacts, which start the compressor and outdoor fan motor. TSH-1 contacts also provide power to the "G" terminal on the thermostat, which energizes the fan relay (F), starting the indoor fan motor (provided the fan switch is in the AUTO position).

While in the normal heating position, "O" terminal, which powers the switch-over valve (SOV) and the evaporator defrost relay (EDR), will remain de-energized by the thermostat. EDR-1 contacts close, bypassing the evaporator defrost control (EDC). EDR-2 contacts close which supply power to the defrost control timer (DFC), allowing it to operate during the heating cycle.

On dual circuit units, when second stage heating is required, "Y2" from the indoor thermostat will energize auxiliary compressor contactor (ACC), which will energize compressor contactor B (CC-B) (ACCB on some models), provided HPCO and LPCO are closed.

Control power for the "B" compressor is supplied from the second transformer (TNS-B) which also powers the supplementary heaters through the heat relay (H) when additional heat is required by "W" terminal.

### Time Temperature Defrost

During the heating cycle, the outdoor coil may require a defrost cycle which is controlled by the defrost control timer (DFC). It is energized continuously, allowing a defrost cycle every 50, 70 or 90 minutes when the defrost terminator (DT) closes at the appropriate line temperature.

The defrost control timer (DFC) opens the circuit to the outdoor fan relay (ODF), and closes a circuit through the timer board which energizes the switch-over valve (SOV), and provides power to the "X2" terminal for supplementary heat placing the unit into the defrost cycle.

The compressor will start 30 seconds after the initiation of the defrost cycle. Supplementary heat is brought on to control indoor temperature during defrost. When the liquid line temperature reaches approximately 70°F, or a 10 minute timed cycled expires, the defrost control timer (DFC) closes the to the outdoor fan relay (ODF) and opens the circuit to the switch-over valve (SOV) and the "X2" terminal, returning the unit to the heating mode.

On dual circuit units, defrost of each outdoor coil is independent and will occur as required. Low pressure cutout (LPCO) is disabled during defrost.

**Note:** *Do not change from the 70 minute full timing cycle in the Southern U.S. ("sunbelt") areas. In Northern climates, the 50 minute defrost cycle may be needed, especially in areas of frequent snow.*

### Supplementary Heat

The 1st stage of supplementary heat is cycled on when the indoor temperature drops approximately 2 degrees below the thermostat setting. TSH-1 establishes compressor operation through the "Y" terminal.

TSH-2 contacts close providing power to the "W" terminal on the indoor thermostat, which supplies power to the supplementary heater control circuit when the auxiliary fan contacts (F-AUX) are closed. Additional supplementary heat or stages of heat may have been added with the use of outdoor thermostats, (not shown on the schematic).

If the outdoor temperature falls below the setpoint on the outdoor thermostat, the additional stages of heat will come on. When it rises above the set point, the system will revert back to 2nd stage supplementary heating.

As the indoor temperature approaches indoor thermostat set point, TSH-2 contacts will open, shutting off supplementary heat and TSH-1 contacts will remain closed until indoor temperature is satisfied, shutting off the complete system.

### **Emergency Heat**

An emergency heat switch (EMERG) is provided within the thermostat. When placed in the emergency heat position, TSH-1 circuit opens to "Y" terminal and closes to "X2" terminal. Supplementary heat now operates on 1st call for heating. "G" terminal sequence remains unchanged at this point. The outdoor thermostats (if used) are by-passed.

### **"T" (Thermistor) Circuit**

The "T" circuit, used with both the manual and automatic changeover thermostats in conjunction with heat pump applications, is used for anticipation of outdoor condition changes. This thermistor varies the resistance as temperature varies in an inverse proportional relationship. It is located in the outdoor unit on the defrost control timer (DFC) and is in series with a fixed value resistor on the thermostat between "R" and "T" terminals. Should this "T" circuit from the outdoor unit become inoperative, the thermostat could be out of calibration by as much as 6 to 10 degrees. Before attempting to calibrate the thermostat, be sure to check this circuit for proper operation.

### **Indoor Fan**

The evaporator fan is controlled by an ON/AUTO switch on the room thermostat. With the switch positioned at AUTO and the unit operating in the cooling mode, fan operation coincides with the thermostat calling for cooling. If the unit is operating in the heating mode while the fan switch is at AUTO, fan operation coincides with the thermostat calling for heating. When the fan switch is positioned at ON, fan operation is continuous.

### **Low Outdoor Ambient Cooling**

The Evaporator Defrost Control is standard equipment on Air Handlers and will permit low ambient cooling down to 35°F. For cooling operation down to 0°F, use an accessory head pressure control on the outdoor unit.

# Maintenance

Perform all of the indicated maintenance procedures at the intervals scheduled. This will prolong the life of the unit and reduce the possibility of costly equipment failure.

## Monthly

Conduct the following maintenance inspections once per month.

### **WARNING**

#### **Hazardous Voltage!**

**Disconnect all electric power, including remote disconnects before servicing. Follow proper lockout/tagout procedures to ensure the power can not be inadvertently energized. Failure to disconnect power before servicing could result in death or serious injury.**

### **WARNING**

#### **Rotating Components!**

**Disconnect all electric power, including remote disconnects before servicing. Follow proper lockout/tagout procedures to ensure the power can not be inadvertently energized. Failure to disconnect power before servicing could result in death or serious injury.**

1. Inspect air filters and clean if necessary.
2. Check unit wiring to ensure all connections are tight and that the wiring insulation is intact.
3. Check drain pans and condensate piping to insure they are free of obstacles.
4. Manually rotate the indoor fan to insure proper operation.
5. Inspect the evaporator and condenser coils for dirt and debris. If the coils appear dirty, clean them.

### **WARNING**

#### **Live Electrical Components!**

**During installation, testing, servicing and troubleshooting of this product, it may be necessary to work with live electrical components. Have a qualified licensed electrician or other individual who has been properly trained in handling live electrical components perform these tasks. Failure to follow all electrical safety precautions when exposed to live electrical components could result in death or serious injury.**

6. With the unit operating in the cooling mode, check the suction and discharge pressures and compare them with Pressure Curve values in unit Service Facts. Record these readings on the "Maintenance Log," see [Table 5, p. 29](#).
7. Observe indoor fan operation and correct any unusual or excessive vibration. Clean blower wheels as needed.

## **Annually (Cooling Season)**

The following maintenance procedures must be performed at the beginning of each cooling season to insure efficient unit operation.

### **WARNING**

#### **Hazardous Voltage!**

**Disconnect all electric power, including remote disconnects before servicing. Follow proper lockout/tagout procedures to ensure the power can not be inadvertently energized. Failure to disconnect power before servicing could result in death or serious injury.**

### **WARNING**

#### **Rotating Components!**

**Disconnect all electric power, including remote disconnects before servicing. Follow proper lockout/tagout procedures to ensure the power can not be inadvertently energized. Failure to disconnect power before servicing could result in death or serious injury.**

1. Perform all of the monthly maintenance inspections.

### **WARNING**

#### **Live Electrical Components!**

**During installation, testing, servicing and troubleshooting of this product, it may be necessary to work with live electrical components. Have a qualified licensed electrician or other individual who has been properly trained in handling live electrical components perform these tasks. Failure to follow all electrical safety precautions when exposed to live electrical components could result in death or serious injury.**

2. With the unit operating, check unit superheat and record the reading in the "Maintenance Log."
3. Remove any accumulation of dust and/or dirt from the unit casing.
4. Remove corrosion from any surface and repaint. Check the gasket around the control panel door to insure it fits correctly and is in good condition to prevent water leakage.

### **WARNING**

#### **Rotating Components!**

**Disconnect all electric power, including remote disconnects before servicing. Follow proper lockout/ tagout procedures to ensure the power can not be inadvertently energized. Secure drive sheaves to ensure rotor cannot freewheel. Failure to secure drive sheaves or disconnect power before servicing could result in death or serious injury.**

5. Inspect the evaporator fan belt. If it is worn or frayed, replace it.
6. Inspect the control panel wiring to insure that all connections are tight and that the insulation is intact.

Lubricate the indoor fan motor bearing with a non detergent 20-weight oil. (To insure good bearing lubrication, condenser fan motor bearings should be lubricated once every six months.)

**Note:** *Some motors are permanently lubricated.*

7. Check refrigerant piping and fittings for leaks.

The following warning complies with State of California law, Proposition 65.

### **WARNING**

#### **Fiberglass Wool!**

**Product contains fiberglass wool. Disturbing the insulation in this product during installation, maintenance or repair will expose you to airborne particles of glass wool fibers and ceramic fibers known to the state of California to cause cancer through inhalation. Glass wool fibers could result in respiratory, skin or eye irritation.**

#### **Precautionary Measures**

- Avoid breathing fiberglass dust.
- Use a NIOSH approved dust/mist respirator.
- Avoid contact with the skin or eyes. Wear long-sleeved, loose-fitting clothing, gloves, and eye protection.



# Warranty

## For Commercial Unitary Equipment Rated Under 20 Tons and Related Accessories

### Products Covered

This warranty is extended by Trane, and applies to the following products:

- All packaged and split system air conditioners and heat pumps have a rated capacity of less than 20 tons.
- All packaged combinations gas/electric air conditioners having a rated capacity of less than 20 tons.
- All packaged combination gas/electric air conditioners having a rated capacity of 1 ½ through 5 tons single phase electric power and used for commercial applications. (As used in this warranty, a commercial application is any application where the end purchaser uses the product for other than personal, family or household purposes.)
- All accessories for the above products which are sold by American Standard Inc. and applied in accordance with American Standard Inc. specifications.

### Basic Warranty

The warrantor warrants for a period of twelve (12) months from the initial start-up or eighteen (18) months from date of shipment, whichever is sooner, that the products covered by this warranty (1) are free from defects in material and manufacture, and (2) have the capacities and ratings set forth in the warrantor's catalogs and bulletins.

### Extended Four-Year Warranty On Compressors

The warrantor warrants for a period of four (4) years commencing twelve (12) months from date of installations or eighteen (18) months from date of shipment, whichever is sooner, that the compressor in any product covered by this warranty (1) is free from defects in material and manufacture, and (2) has the capacities and ratings set forth in the warrantor's catalogs and bulletins.

### Extended Four-Year Warranty On Heat Exchangers

The warrantor warrants for a period of four (4) years commencing twelve (12) months from date of installations or eighteen (18) months from date of shipment, whichever is sooner, that the gas-fired heat exchanger in any products covered by this warranty (1) is free from defects in material and manufacture, and (2) has the capacities and ratings set forth in the warrantor's catalogs and bulletins.

### Exclusions And Limitations

The warrantor's obligations and liabilities under this warranty are limited to furnishing F.O.B. factory or warehouse at the warrantor-designated shipping point, freight allowed to Buyer's city (or port of export for shipments outside the conterminous United States) a replacement product or, at the option of the warrantor, parts for the repair of the product not conforming to this warranty and which have been returned to the warrantor.

The warrantor's warranty is conditional on the Customer providing written notice to the warrantor within thirty (30) days of the discovery of the defect. No product shall be returned to the warrantor without the warrantor's written permission. No liability whatever shall attach to warrantor until said products have been fully paid for and then said liability shall be limited to the purchase price of the equipment shown to be defective.

The warranty does not apply to any compressor or gas-fired heat exchanger which has been repaired or altered in such manner as, in the judgement of the warrantor, affects its stability or reliability. This warranty does not cover (1) any heat exchanger which has been fired with an

improper type of fuel (2) a heat exchanger which is installed in a beauty parlor, dry cleaning establishment, de-greasing plant or in any corrosive atmosphere; or (3) any heat exchanger which is not shown to be defective by the warrantor's inspection.

This warranty does not cover damage due to accident, abuse, improper use, external causes, freezing, corrosion, erosion or deterioration.

Local transportation, related service labor, air filters, diagnosis calls, refrigerant and related items are not covered.

THE WARRANTY AND LIABILITY SET FORTH HEREIN ARE IN LIEU OF ALL OTHER WARRANTIES AND LIABILITIES, WHETHER IN CONTRACT OR IN NEGLIGENCE, EXPRESS OR IMPLIED, IN LAW OR IN FACT, INCLUDING IMPLIED WARRANTIES OR MERCHANTABILITY AND FITNESS FOR A PARTICULAR PURPOSE AND ANY IMPLIED WARRANTIES OTHERWISE ARISING FROM THE COURSE OF DEALING OR TRADE. IN NO EVENT SHALL THE WARRANTOR BE LIABLE FOR ANY INCIDENTAL OR CONSEQUENTIAL DAMAGES.

The warrantor makes certain further warranty protection available on an optional, extra-cost basis. Any further warranty must be in writing. If you wish further help or information concerning this warranty, contact:

Trane — Warrantor  
2701 Wilma Rudolph Blvd.  
Clarksville, TN 37040

## **Commercial Equipment Rated 20 Tons and Larger and Related Accessories (Parts Only)**

### **Products Covered**

This warranty is extended by Trane, and applies only to commercial equipment rated 20 tons and larger and related accessories purchased and retained for use within the U.S.A. and Canada.

Warrantor warrants for a period of 12 months from initial start-up or 18 months from date of shipment, whichever is less, that the products covered by this warranty (1) are free from defects in material and manufacture, and (2) have the capacities and ratings set forth in catalogs and bulletins; provided, that no warranty is made against corrosion, erosion or deterioration.

Warrantor's obligations and liabilities under this warranty are limited to furnishing, F.O.B. factory replacement parts (or equipment at the option of Warrantor) for all Warrantor's products not conforming to this warranty. Warrantor shall not be obligated to pay for the cost of lost refrigerant. No liability whatever shall attach to Warrantor until said products have been paid for and then said liability shall be limited to the purchase price of the equipment shown to be defective.

The Warranty and Liability set forth herein are in lieu of all other warranties and liabilities, whether in contract or in negligence, express or implied, in law or in fact, including implied warranties of merchantability and fitness for particular use, and in no event shall warrantor be liable for any incidental or consequential damages

Some states do not allow limitations on how long an implied warranty lasts or do not allow the exclusion or limitation of incidental or consequential damages, so the above limitation or exclusion may not apply to you. This warranty gives you specific legal rights, and you may also have other rights which vary from state to state.

Trane — Warrantor  
2701 Wilma Rudolph Blvd.  
Clarksville, TN 37040  
GW-598-4799

# Wiring Diagram Matrix

**Note:** Wiring diagrams are available via e-Library or through the local sales office.

| WIRING DIAGRAM NO. | DIAGRAM TYPE                               | UNIT MODEL NO'S  |
|--------------------|--|--|
| 4367-0325          | ElectroMechanical Connection and Schematic | TTA120B3, TTA120B4, TTA120BW, TTA100BD, TTA150B3, TTA150B4, TTA150BW, TTA125BD, TTA120BK, TTA150BK   |
| 4367-0326          | ElectroMechanical Connection and Schematic | TTA100CD, TTA120C3, TTA120C4, TTA120CW   |
| 4367-0327          | ElectroMechanical Connection and Schematic | TWA090A3, TWA090A4, TWA090AW, TWA120A4, TWA120AW, TWA075AD, TWA100AD   |
| 4367-0335          | ElectroMechanical Connection and Schematic | TTA155BD, TTA180B3, TTA180B4, TTA180BW, TTA180BK, TTA200BD, TTA240B4, TTA240BW, TTA240BK   |
| 4367-0336          | ElectroMechanical Connection and Schematic | TTA240B3   |
| 4367-0337          | ElectroMechanical Connection and Schematic | TTA155CD, TTA180C3, TTA180C4, TTA180CW   |
| 4367-0338          | ElectroMechanical Connection and Schematic | TWA200BD, TWA240B4, TWA240BW   |
| 4367-0339          | ElectroMechanical Connection and Schematic | TWA155BD, TWA180B3, TWA180B4, TWA180BW   |
| 4367-0340          | ElectroMechanical Connection and Schematic | TWA240B3   |
| 4367-0341          | ElectroMechanical Connection and Schematic | TTA120A3   |
| 4367-0342          | ElectroMechanical Connection and Schematic | TTA075AD, TTA085AD, TTA090A3, TTA090A4, TTA090AW, TTA090AK, TTA100AD, TTA120A4, TTA120AW, TTA120AK   |
| 4367-0343          | ElectroMechanical Connection and Schematic | TWA090A3, TWA090A4, TWA090AW, TWA120A4, TWA120AW, TWA075AD, TWA100AD   |
| 4367-0344          | ElectroMechanical Connection and Schematic | TWA120A3   |
| 4367-0345          | ReliaTel Connection and Schematic          | TTA240B3   |
| 4367-0346          | ElectroMechanical Connection and Schematic | TWE060A3, TWE060C3   |
| 4367-0347          | ElectroMechanical Connection and Schematic | TWE090A1, TWE120A1   |
| 4367-0349          | ElectroMechanical Connection and Schematic | TWE155BD, TWE180BW, TWE180B3, TWE180B4, TWE180BK, TWE200BD, TWE240BW, TWE240B3, TWE240B4, TWE240BK, TWE155CD, TWE180CW, TWE180C3, TWE180C4, TWE180CK, TWE200CD, TWE240CW, TWE240C3, TWE240C4, TWE240CK |
| 4367-0350          | ElectroMechanical Connection and Schematic | TWE090B3, TWE120B3, TWE120BK   |
| 4367-0351          | ElectroMechanical Connection and Schematic | TWE100BD, TWE120BW   |
| 4367-0352          | ElectroMechanical Connection and Schematic | TWE060B1, TWE090B1, TWE120B1   |
| 4367-0353          | ElectroMechanical Connection and Schematic | TWE060B3   |
| 4367-0354          | ElectroMechanical Connection and Schematic | TWE060B4   |
| 4367-0355          | ElectroMechanical Connection and Schematic | TWE090AK, TWE090A3, TWE090C3, TWE120AK, TWE120A3, TWE120C3   |
| 4367-0356          | ElectroMechanical Connection and Schematic | TWE060A1, TWE060C1   |
| 4367-0357          | ElectroMechanical Connection and Schematic | TWE050AD, TWE060AK, TWE060AW, TWE060A4, TWE060CW, TWE060C4   |
| 4367-0358          | ElectroMechanical Connection and Schematic | TWE075AD, TWE090AW, TWE100AD, TWE120AW, TWE090CW, TWE120CW   |
| 4367-0359          | ReliaTel Connection and Schematic          | TTA155BD, TTA180B3, TTA180B4, TTA180BW, TTA180BK, TTA200BD, TTA240B4, TTA240BW, TTA240BK   |
| 4367-0360          | ReliaTel Connection and Schematic          | TTA155CD, TTA180C3, TTA180C4, TTA180CW   |
| 4367-0361          | ReliaTel Connection and Schematic          | TTA100CD, TTA120C3, TTA120C4, TTA120CW   |
| 4367-0362          | ReliaTel Connection and Schematic          | TTA120B3, TTA120B4, TTA120BW, TTA100BD, TTA150B3, TTA150B4, TTA150BW, TTA125BD, TTA120BK, TTA150BK   |
| 4367-0363          | ReliaTel Connection and Schematic          | TTA075AD, TTA085AD, TTA090A3, TTA090A4, TTA090AW, TTA090AK, TTA100AD, TTA120A4, TTA120AW, TTA120AK   |
| 4367-0364          | ReliaTel Connection and Schematic          | TTA120A3   |
| 4367-0444          | ReliaTel Connection and Schematic          | TTA200FD, TTA240F4, TTA240FW, and TTA240FK   |





---

|                         |                         |
|-------------------------|-------------------------|
| Literature Order Number | TWA-SVX01A-EN           |
| Date                    | December 2006           |
| Supersedes              | PKG-PR0012-EN July 2006 |

---

**[www.trane.com](http://www.trane.com)**

*For more information, contact your local Trane office or e-mail us at [comfort@trane.com](mailto:comfort@trane.com)*

Trane has a policy of continuous product and product data improvement and reserves the right to change design and specifications without notice.