

DAMMON
ENGINEERING, INC.

CHIEF ENGINEER
EMMETT
DAMMON, P.E.

CHIEF ARCHITECT
ROBERT
WILTSE

1095 FLORIDA AVENUE
SUDDALL, LA. 70456
OFFICE: 985-649-5632
FAX: 985-641-5950

WWW.DAMMONENGINEERING.COM
EMAIL:
DAMMONENG@BELL.SOUTH.NET

ARCHITECTURE
ENGINEERING
STUDIES
PLANNING
INVESTIGATION
EXPERT WITNESS

**BOILER
INSTALLATION**

SOUTHEAST
LOUISIANA
HOSPITAL
23515 HWY 190
MANDEVILLE LA

**PLAN VIEW
PIPING
& SCHEMATIC
DIAGRAMS**

REV.: 12/09/08

SCALE: AS NOTED

JOB#: 1985

DATE: 12-09-08

SHEET #1

P-1

OF 1

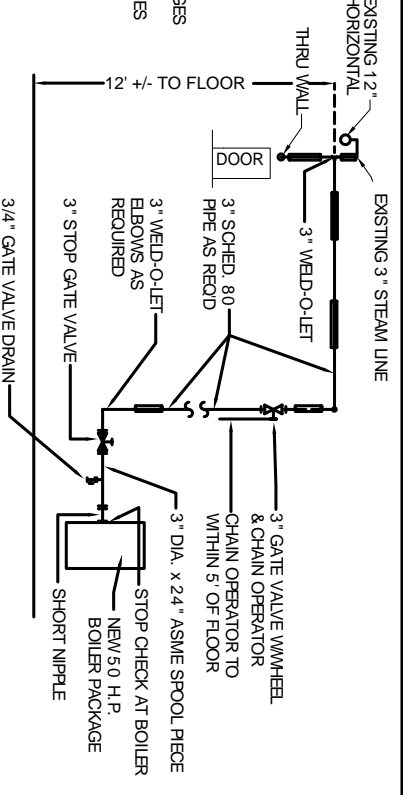
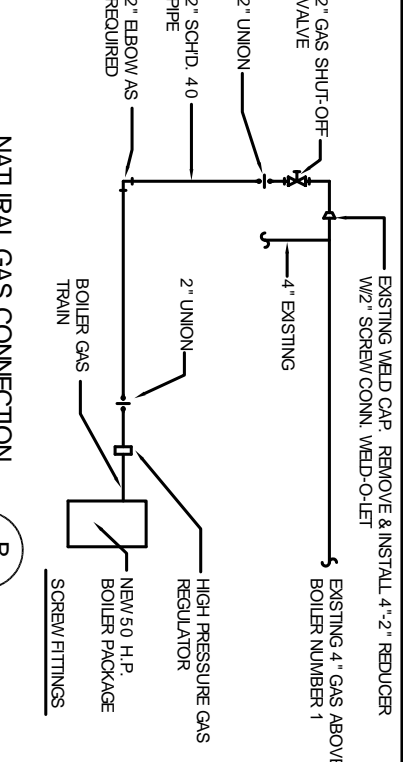
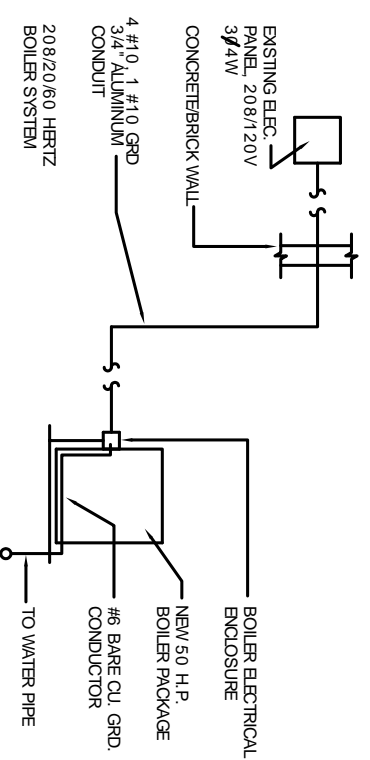

- NOTES:**
- FINAL DIMENSIONS WILL VARY, DEPENDING ON THE UNIT FURNISHED AND INSTALLED. IT IS THE CONTRACTOR'S RESPONSIBILITY TO VERIFY ALL EXISTING CONDITIONS. VERIFY THAT HIS PROPOSED UNIT WILL FIT THE AREA AND NOT INTERFERE WITH EXISTING EQUIPMENT.
 - ALL SCHEMATIC VIEWS OF PIPING SYSTEMS REPRESENT GENERAL VIEWS OF CONNECTIONS TO BE MADE TO A PACKAGE UNIT BOILER THAT CONTAINS ALL NECESSARY PUMPS, GAS TRAIN, ELECTRICAL SYSTEMS, VENTS, DRAINS, ETC. TO PROVIDE A COMPLETE AND OPERATIONAL SYSTEM. CONTRACTOR SHALL PROVIDE AND INSTALL ALL FITTINGS, PIPE, INSULATION, ETC. REQUIRED TO THE COMPLETE SYSTEM.
 - BLOWDOWN PIPE SHALL BE RAIN SO THAT PIPE ON FLOOR DOES NOT REPRESENT A TRIPPING HAZARD.
 - PROVIDE ELECTRICAL POWER SIZED TO ACCOMMODATE BOILER PACKAGE FURNISHED. INSTALL 3 POLE BREAKER IN PANELBOARD.
 - FINAL PLACEMENT OF BOILER PACKAGE & PAD SHALL BE DETERMINED BY ANY OVERHEAD PIPES, ETC. THAT BLOCK A STRAIGHT VERTICAL LINE REQUIRED FOR BREACHING THROUGH ROOF.
 - DIMENSIONS SHOWN FOR HOUSE KEEPING PAD MAY VARY, ACCORDING TO EQUIPMENT FURNISHED.
 - CONTRACTOR SHALL VERIFY EXISTING PIPE MATERIALS AND CONNECTION METHODS AND SHALL USE SAME PIPE THICKNESS, MATERIAL ETC. AS THOSE EXISTING FOR NEW WORK.
 - SEE PROJECT BOOK FOR BOILER PKG SPECIFICATIONS.
 - ELECTRICAL CONDUCTORS SHALL BE #12 CU TYPE THIN CONDUIT SHALL BE #2 RIGID ALUMINUM.
 - PAINT NEW CONCRETE TO MATCH FLOOR. TOUCH UP PAINT ON ALL NEW EQUIPMENT.
 12. PAINT NEW CONCRETE TO MATCH FLOOR. TOUCH UP PAINT ON ALL NEW EQUIPMENT.

