

**BULKHEAD PLAN**

SCALE: 1" = 30'-0"

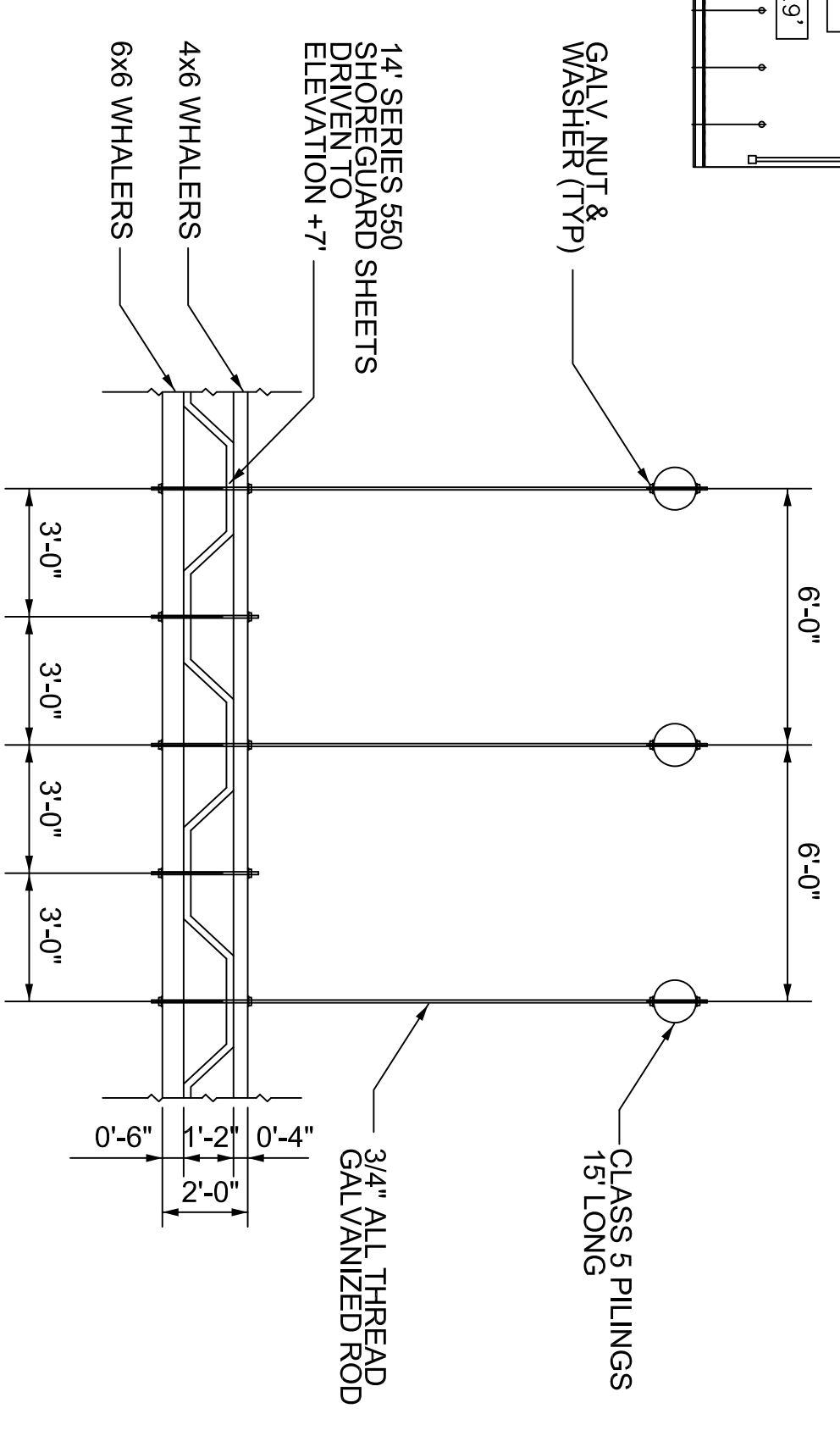

**BULKHEAD DETAIL**

SCALE: 1/4" = 1'-0"