

UPLIFT CONNECTIONS- 130MPH WINDS EXP. "B"						
CONNECTION	FRAMING SPACING (in.)	ROOF SPAN (ft.)	U	L	S	NUM. OF 8d COM. NAILS OR 10d BOX NAILS IN EA. END OF 1-1/4"x20 GA. STRAP
ROOF ASSEMBLY TO WALL ASSEMBLY	16" O.C.	17	386	246	109R	4
WALL ASSEMBLY TO WALL ASSEMBLY	16" O.C.	17	386	246	109R	4
WALL ASSEMBLY TO FOUNDATION	16" O.C.	17	170	185	436	4

THERMAL COMPONENT CRITERIA (U-FACTOR AND R-VALUE)					
MAX. GLAZING U-FACTOR	MINIMUM INSULATION R-VALUE				
	CEILINGS	WALLS	FLOORS	BASEMENT WALLS	CRAWL SPACE WALLS
.75	R-26	R-13	R-11	R-5	R-5

WALL SHEATH. OR CLAD. REQ. FOR WIND LOAD-EXP. B				
SHEATHING LOCATION	STUD SPAC.	E		F
		MAX. NAIL SPAC. FOR 8d COM. NAILS OR 10d BOX NAILS (INCHES, O.C.)		
INTERIOR ZONE	12" O.C.	6	12	
	16" O.C.	6	12	
	24" O.C.	6	12	
PERIMETER EDGE ZONE	12" O.C.	6	12	
	16" O.C.	6	12	
	24" O.C.	6	12	

130 MPH WINDS-EXPOSURE "B" (TYP.)

WINDBORNE DEBRIS PROTECTION FASTENING SCHEDULE FOR WOOD STRUCTURAL PANELS			
FASTENER TYPE	FASTENER SPACING		
	PANEL SPAN ≤ 4 FOOT	4 FOOT PANEL SPAN ≤ 6 FOOT	6 FOOT PANEL SPAN ≤ 8 FOOT
2-1/2" #6 WOOD SCREWS	16"	12"	9"
2-1/2" #8 WOOD SCREWS	16"	16"	12"

WINDOWS IN BUILDINGS LOCATED IN WIND BORNE DEBRIS REGIONS SHALL HAVE GLAZED OPENINGS PROTECTED FROM WINDBORNE DEBRIS. WOOD STRUCTURAL PANELS WITH A MIN. THICKNESS OF 7/16" AND A MAX. SPAN OF 8 FEET SHALL BE PERMITTED FOR OPENING PROTECTION IN ONE AND TWO STORY BUILDINGS. PANELS SHALL BE PRECUT TO COVER THE GLAZED OPENINGS WITH ATTACHMENT HARDWARE PROVIDED.

HEADER NAILING SCHEDULE			
DESCRIPTION	NUM. OF COM. NAILS	NUM. OF BOX NAILS	SPACING
HEAD. TO HEAD. (FACE-NAILED)	8d	10d	6" O.C. EDGES/ 12" O.C. FIELD

NOTE: ALL HEADERS SHALL HAVE SOLID BLOCKING

JACK STUD REQUIREMENTS-FOR INTERIOR LOADBEARING WALLS																
HEADER SUPPORTING	HEADER SPAN (ft.)	ROOF SPAN (ft.)														
		12 FEET					24 FEET					36 FEET				
		3"	4.5"	5"	6.5"	3"	4.5"	5"	6.5"	3"	4.5"	5"	6.5"			
NO. JACK STUDS REQ.																
ROOF AND CEILING	2	1	1	1	1	1	1	1	1	1	1	1				
	4	1	1	1	1	1	1	1	1	1	1	1				
	6	1	1	1	1	1	1	1	1	2	1	1				
	8	1	1	1	1	2	1	1	1	2	2	1				
	10	1	1	1	1	2	2	1	1	3	2	2				
	12	1	1	1	1	2	2	2	1	3	2	2				
	14	2	1	1	1	3	2	2	2	4	3	3				
ROOF, CEILING, AND 1 CENTER BEARING FLR.	2	1	1	1	1	1	1	1	1	2	1	1				
	4	1	1	1	1	2	1	1	3	2	2					
	6	2	1	1	1	3	2	2	4	3	3					
	8	2	2	1	1	3	2	2	5	3	3					
	10	2	2	2	1	4	3	3	2	6	4	3				
	12	3	2	2	2	5	3	3	3	7	5	4				
	14	3	2	2	2	5	4	3	3	8	5	4				
16	4	3	2	2	6	4	4	3	9	6	5					

HEADER WIDTH-3" (2-2x), 4.5" (3-2x), 5", 6.5" (4-2x) EACH W/ 1/2" PLYWD. SPACER BETWEEN

SILL or BOTTOM PLATE TO FND. CONNECTIONS RESISTING UPLIFT LOADS- 130MPH WINDS EXP. "B"			
BOTTOM PLATE TO FND. ANCHOR BOLT CONNECTION RESISTING	FOUNDATION SUPPORTING	MAX. ANCHOR BOLT SPACING (in.)	
		8' END ZONES	INTERIOR ZONES
UPLIFT LOADS	1-3 STORIES	28	33

SILL or BOTTOM PLATE TO FND. CONNECTIONS RESISTING SHEAR LOADS- 130MPH WINDS EXP. "B"			
BOTTOM PLATE TO FND. ANCHOR BOLT CONNECTION RESISTING	FOUNDATION SUPPORTING	MAX. ANCHOR BOLT SPACING (in.)	
		1/2" ANC. BOLTS	5/8" ANC. BOLTS
SHEAR LOADS	1-3 STORIES	30	45

ROOF UNDERLAYMENT APPLICATION

FOR ROOF SLOPES FROM TWO UNITS VERTICAL IN 12 UNITS HORIZONTAL (17-PERCENT SLOPE), UP TO FOUR UNITS VERTICAL IN 12 UNITS HORIZ. (33-PERCENT SLOPE), UNDERLAYMENT SHALL BE TWO LAYERS APPLIED IN THE FOLLOWING MANNER:

APPLY A 19 INCH STRIP OF UNDERLAYMENT FELT PARALLEL WITH AND STARTING AT THE EAVES, FASTENED SUFFICIENTLY TO HOLD IN PLACE. STARTING AT THE EAVE, APPLY 36 INCH WIDE SHEETS OF UNDERLAYMENT, OVERLAPPING SUCCESSIVE SHEETS 19 INCHES, AND FASTENED SUFFICIENTLY TO HOLD IN PLACE.

FOR ROOF SLOPES OF FOUR UNITS VERTICAL IN 12 UNITS HORIZONTAL (33-PERCENT SLOPE) OR GREATER, UNDERLAYMENT SHALL BE ONE LAYER APPLIED IN THE FOLLOWING MANNER:

UNDERLAYMENT SHALL BE APPLIED SHINGLE FASHION, PARELLEL TO AND STARTING FROM THE EAVE AND LAPPED 2 INCHES, FASTENED SUFFICIENTLY TO HOLD IN PLACE. END LAPS SHALL BE OFFSET BY 6 FEET.

SHINGLE APPLICATION/FASTENING

ASPHALT STRIP SHINGLES SHALL HAVE A MINIMUM OF SIX FASTENERS PER SHINGLE WHERE THE ROOF IS IN ONE OF THE FOLLOWING CATEGORIES:

- THE BASIC WIND SPEED IS 110 MPH OR GREATER AND THE EAVE IS 20 FEET OR HIGHER ABOVE GRADE.
- THE BASIC WIND SPEED IS 120 MPH OR GREATER.
- SPECIAL WIND ZONES.

UPLIFT CONNECTIONS

ROOF ASSEMBLY TO WALL ASSEMBLY:

UPLIFT CONNECTIONS SHALL BE FROM RAFTER OR TRUSS TO WALL STUD. WHEN RAFTERS OR TRUSSES ARE NOT LOCATED DIRECTLY ABOVE STUDS, RAFTERS SHALL BE ATTACHED TO THE WALL PLATE AND THE WALL TOP PLATE SHALL BE ATTACHED TO THE WALL STUD WITH UPLIFT CONNECTIONS. UPLIFT CONNECTIONS SHALL BE IN ACCORDANCE WITH TABLE.

WALL ASSEMBLY TO WALL ASSEMBLY:

STORY TO STORY UPLIFT CONNECTIONS FROM UPPER STORY WALL STUD TO LOWER STORY WALL STUD. WHEN UPPER STORY WALL STUDS ARE NOT LOCATED DIRECTLY ABOVE LOWER WALL STUDS, THE STUDS SHALL BE ATTACHED TO A COMMON MEMBER IN THE FLOOR ASSEMBLY BY UPLIFT CONNECTIONS. UPLIFT CONNECTIONS SHALL BE IN ACCORDANCE WITH TABLE.

WALL ASSEMBLY TO FOUNDATION:

FIRST FLOOR WALL STUDS SHALL BE CONNECTED TO THE FOUNDATION, SILL PLATE, OR BOTTOM PLATE. A MINIMUM OF A 1-1/4" x 20 GA. ASTM A653 GRADE 33 STEEL STRAP SHALL BE NAILED TO THE WALL STUDS AND HAVE A MINIMUM EMBEDMENT OF 7 INCHES IN CONCRETE FOUNDATIONS AND SLABS-ON-GRADE, 15 INCHES IN MASONRY BLOCK FOUNDATIONS, OR BE LAPPED UNDER THE BOTTOM PLATE, 3 INCH SQUARE WASHERS SHALL BE USED ON THE ANCHOR BOLTS AND ANCHOR BOLT SPACINGS SHALL NOT EXCEED THE REQUIREMENTS. STEEL STRAPS EMBEDDED IN OR IN CONTACT WITH SLAB-ON-GRADE OR MASONRY BLOCK FOUNDATIONS SHALL BE HOT-DIPPED GALV. AFTER FABRICATION, OR MANUF. FROM G185 OR 2450 GALV. STL. CONNECTIONS SHALL BE IN ACCORDANCE WITH TABLE.

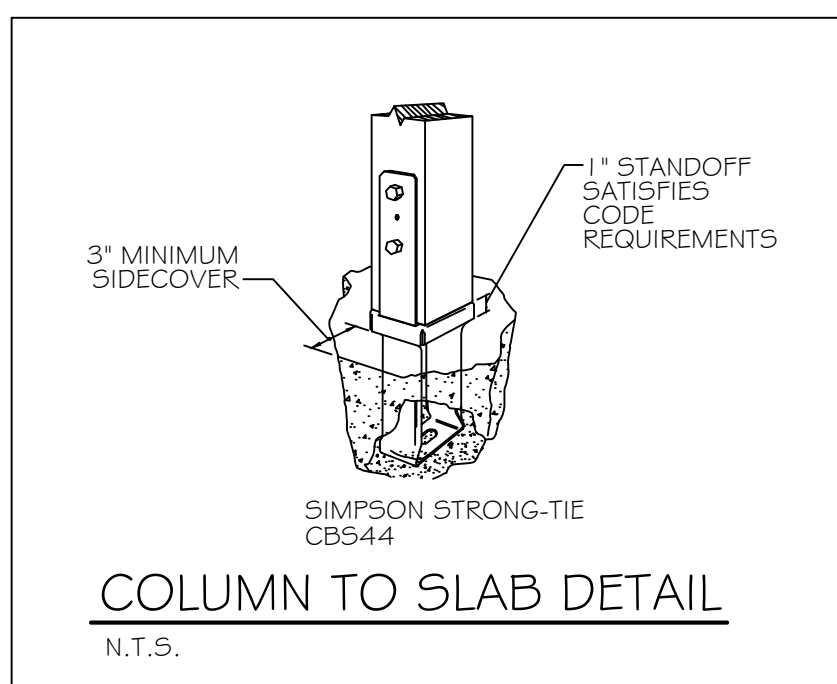
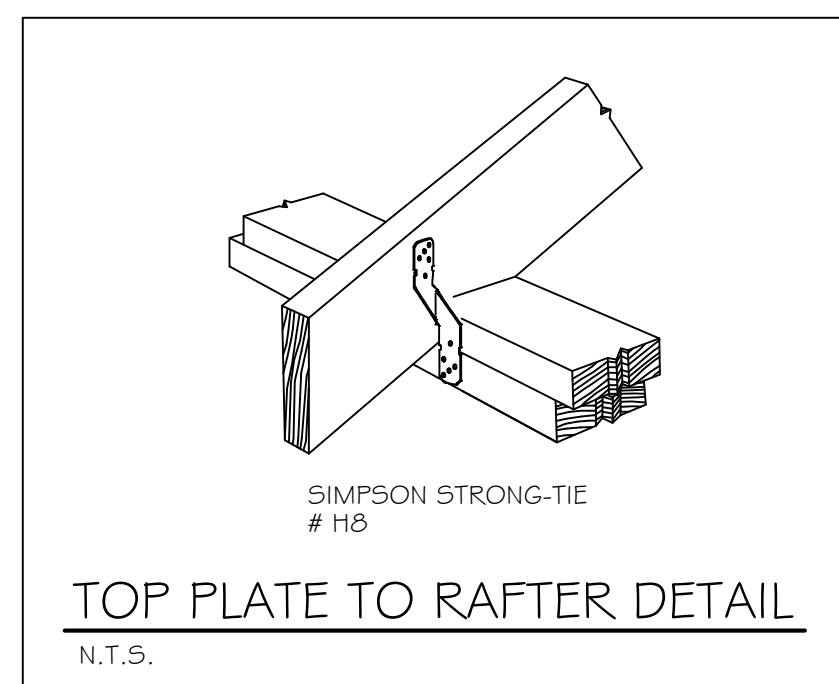
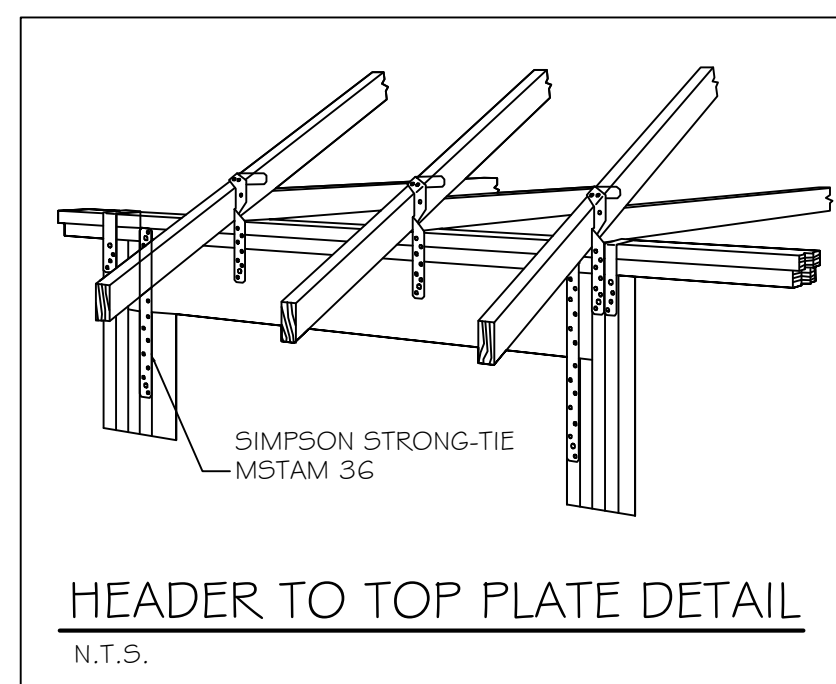
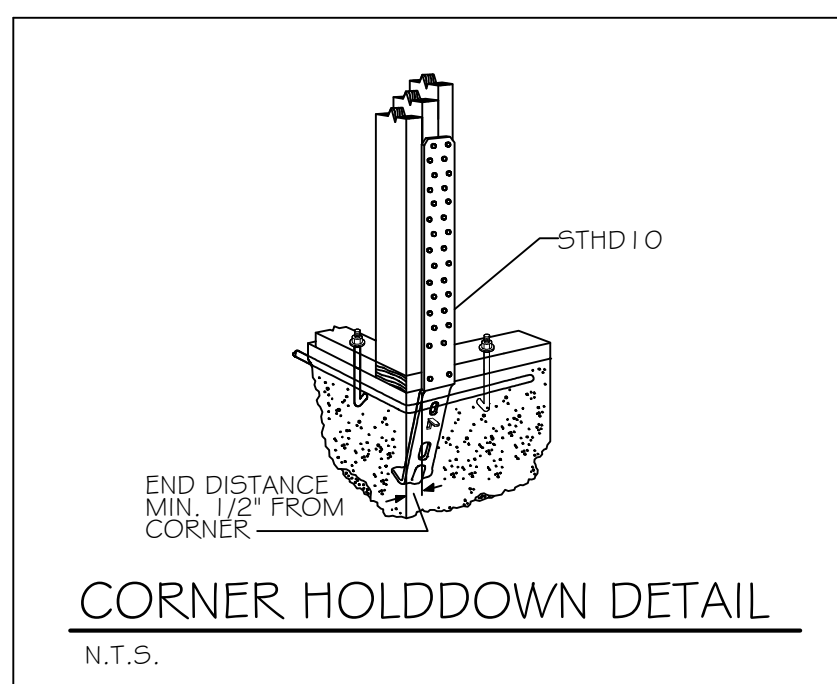

STRUCTURAL NOTES

DESIGN LOADS:
WIND: 130 MPH
FLOOR: 40 PSF LIVE LOAD
ROOFS: 20 PSF LIVE LOAD

WIND DESIGN CRITERIA:
METHOD 2-ANALYTICAL METHOD PROCEDURE FOR ASCE 7-05

DESIGNED FOR: ENCLOSED BUILDING
WIND VELOCITY: 130 MPH (3 SECOND GUST)

TERRAIN EXPOSURE CATEGORY: B
GUST EFFECT FACTOR: 0.85
INTERNAL PRESSURE: +/- 0.18
BUILDING CATEGORY: III
IMPORTANCE FACTOR: 1.15

WALL PRESURE FOR COMPONENT AND CLADDING: (130 MPH)

INTERIOR ZONES (ZONE 4)

EFFECTIVE AREA (FT)	DESIGN PRESSURE (PSF)
10	+35.3 -38.2
20	+33.7 -36.7
50	+31.6 -34.6
100	+30.0 -33.0

END ZONES (ZONE 5): WITHIN 6 F.T. OF CORNERS

ZONE	DESIGN PRESSURE (PSF)
10	+35.3 -47.2
20	+33.7 -44.0
50	+31.6 -39.8
100	+30.0 -36.7

ROOF PRESSURE FOR COMPONENT AND CLADDING: (130MPH)

ZONE	DESIGN PRESSURE (PSF)
1	+20.3/-32.3
2	+20.3/-68.1
3	+20.3/-68.1

NOTE:
ALL EXTERIOR DOORS AND WINDOWS SHALL BE DESIGNED AND INSTALLED TO WITHSTAND DESIGN WIND LOADS BASED ON ASCE 7-05

SITE PREPARATION:

- SEE FOUNDATION PLANS BY COAST POST-TENSIONED SYSTEMS FOR REQUIREMENTS

CONCRETE:

- SEE FOUNDATION PLANS BY COAST POST-TENSIONED SYSTEMS FOR REQUIREMENTS

TIMBER:

- STRUCTURAL TIMBER EXCEPT STUDS SHALL BE #2 SOUTHERN YELLOW PINE (19% MAX. MOISTURE CONTENT), WOOD AGAINST MASONRY OR WET-USE ENVIRONMENTS TO BE PRESSURE TREATED.
- EXTERIOR AND SHEAR STUD WALLS TO HAVE SOLID BLOCKING AT SHEATHING JOINTS
- STUDS TO BE #2 SPRUCE, PINE, OR FIR @ 16" O.C.
- PLYWOOD/OSB SHEATHING SHALL BE APA RATED (PRP-108). ALL PANELS WHICH HAVE ANY EDGE OR SURFACE PERMANENTLY EXPOSED TO WEATHER SHALL BE CLASSIFIED EXTERIOR.

ROOF SHEATHING: 5/8" APA RATED SHEATHING W/ 8d THREADED NAILS @ 3" O.C. EDGE AND 12" O.C. INTERIOR SPACING.

WALL SHEATHING: 5/8" APA RATED SHEATHING W/ 8d THREADED NAILS @ 3" O.C. EDGE AND 12" O.C. INTERIOR SPACING.

- STRUCTUAL ADHESIVES: SIMPSON SET CONTRACTOR SHALL FOLLOW ALL INSTALLATION INSTRUCTIONS AND RECOMMENDATIONS EXPLICITLY.

- ROOF RAFTER ANCHORS: ALL RAFTERS SHALL BE ANCHORED W/ SIMPSON H8 (MINIMUM).

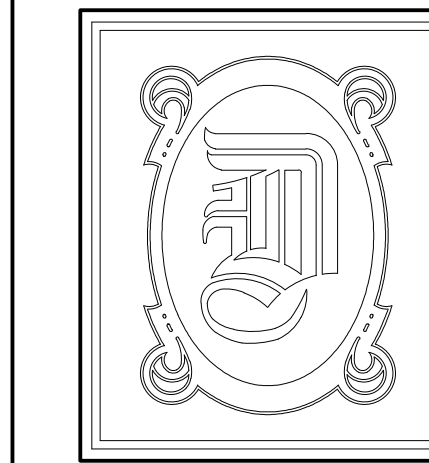

DAMMON
ENGINEERING, INC.

CHIEF ENGINEER
EMMETT
DAMMON, P.E.

CHIEF ARCHITECT
ROBERT
WILTSE

1095 FLORIDA AVENUE
SLIDELL, LA. 70456
OFFICE: 985-649-5832
FAX: 985-641-5950

WEBSITE:
WWW.DAMMONENGINEERING.COM

EMAIL:
DAMMONENG@BELLSOUTH.NET

ARCHITECTURE

ENGINEERING

STUDIES

PLANNING

INVESTIGATION

EXPERT WITNESS

ANDERSON
MEMORY CARE
4104 DAUPHINE ST.
SLIDELL, LA
70458

MAIN WIND
FORCE RESISTING
SYSTEM
NOTES

REV:

SCALE: AS NOTED

JOB#:

DATE: 07-15-10

SHEET

5-6

OF