

2nd FLOOR PLAN
SCALE 3/16" = 1'-0"

GA FILE NO. WP 3380 **GENERIC**

ONE LAYER 5/8" TYPE X Gypsum WALLBOARD OR Gypsum VERBER BOARD APPLIED TO EACH SIDE OF 2" CORE STUDS 16" O.C. STAGGERED 8" O.C. ON 2x8 PLATES WITH 60 COATED WALS. 1-7/8" LONG, 0.0915 SHANK, 1/4" HEADS, 7" O.C. (RIGHT TO ROOF RISE) JOINTS STAGGERED 24" ON OPPOSITE SIDES. HORIZONTAL BRACING REQUIRED AT MID HEIGHT. (LOAD BRACING)

THICKNESS: APPROX WEIGHT 7 PSF @ 3/4"

1 HOUR FIRE: 40 TO 44 STC SOUND

PRE TEST: UL R1319-4, 6, 6-17-52; UL R2712-39, 1, 2-9-86; U.C. DESIGN (U005)

SOUND TEST: ESTIMATED

GA FILE NO. WP 3514 **GENERIC**

ONE LAYER 5/8" TYPE X Gypsum WALLBOARD OR Gypsum VERBER BOARD APPLIED TO EACH SIDE OF 2" CORE STUDS 16" O.C. STAGGERED 8" O.C. ON 2x8 PLATES WITH 60 COATED WALS. 1-7/8" LONG, 0.0915 SHANK, 1/4" HEADS, 7" O.C. (RIGHT TO ROOF RISE) JOINTS STAGGERED 24" ON OPPOSITE SIDES. (LOAD BRACING)

THICKNESS: APPROX WEIGHT 7 PSF @ 3/4"

1 HOUR FIRE: 35 TO 39 STC SOUND

PRE TEST: SWR 01-4511-4/19, 8-19-02; U.C. DESIGN (U005)

SOUND TEST: ESTIMATED

- GENERAL NOTES:**
1. REFER TO CONSTRUCTION.
 - A. REPAIR ALL EXISTING ROOF LEAKS
 - B. REPAIR ALL EXISTING 2ND FLOOR DECKING
 - C. REPAIR ALL EXISTING 2ND FLOOR DECKING THAT MAY BE ROTTEN OR NON-RATED
 2. INTERIOR WALLS AND CEILING SHALL HAVE A FAME SPREAD OF 76-200 AND A SMOKE DEVELOPMENT RATING OF 0-450 ACCORDING TO IBC 2006 SECTION 803.1.1.
 3. INTERIOR WALL AND CEILING FINISH MATERIALS IN THE DOMINANT OCCUPANCY COMPILING WITH NFPA 101 SEC. 10.2 SHALL BE PERMITTED AS FOLLOWS:
 - A. EXT ENCLOSURES: CLASS A
 - B. LOBBIES AND CORRIDORS: CLASS A OR CLASS B
 - C. OTHER SPACES: CLASS A, CLASS B OR CLASS C

NOTE THIS BUILDING SHALL BE FULLY SPRINKLED.

- FIRE PROTECTION NOTES:**
1. PROVIDE AN APPROVED AUTOMATIC FIRE ALARM AND SPRINKLER SYSTEM IN ACCORDANCE WITH IBC 2006 SEC 903.2.7. PLANS BY OTHERS.
 2. PROVIDE FIRE EXTINGUISHERS IN ACCORDANCE WITH NFPA 10.
 3. ALL FIREWALLS SHALL DEVISE TO ROOF DECK.

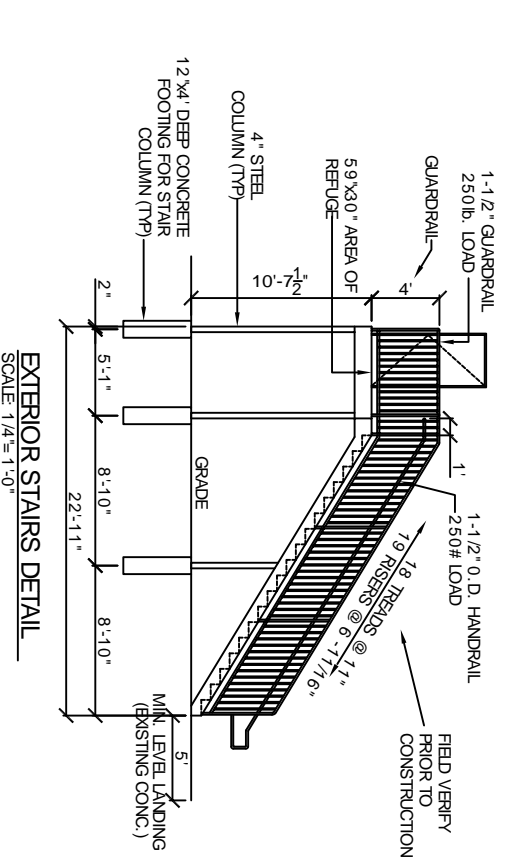

DOOR AND HARDWARE SCHEDULE

#	SIZE	TYPE	FRAME	HINGE	LOOK	ACCESSORIES	REMARKS
1	30x6/8x1-3/4"	WOOD			PASSAGE		130 MPH WIND 60 MIN RATED
2	30x6/8x1-3/4"	METAL			PRIVACY		60 MIN RATED
3	30x6/8x1-3/4"	ALUM./GLASS			DEADBOLT		60 MIN RATED
4	(2) 30x6/8x1-3/4"	STEEL			KEYED HANDLE		60 MIN RATED
5	30x6/8x1-3/4"	ALUMINUM			PUSH PULL		60 MIN RATED
6	30x6/8x1-3/4"	WOOD			WEATHERSTRIP		60 MIN RATED
7	30x6/8x1-3/4"	DOUBLE SWING			DOOR STOP		60 MIN RATED
		BUTT			ALARM		
					CLOSER		

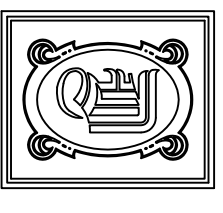

DAMMON ENGINEERING, INC.
CHIEF ENGINEER
EMMETT DAMMON, P.E.
DAMMON, P.E.
CHIEF ARCHITECT
ROBERT WILTSE

1095 FLORIDA AVENUE
SUDDALL, LA. 70456
OFFICE: 985-649-5832
FAX: 985-641-5950
WWW.DAMMONENGINEERING.COM
WEBSITE: DAMMONENGINEERING.COM
EMAIL: DAMMONING@BELLOUTH.NET

ARCHITECTURE
ENGINEERING
STUDIES
PLANNING
INVESTIGATION
EXPERT WITNESS

ALDERSGATE UNITED METHODIST ALTERATIONS AND RENOVATIONS

DALE KIMBALL
2515 CAREY STREET
SUDDALL, LA

SECOND FLOOR PLAN

REV: 6-1-09

SCALE: AS NOTED

JOB#: 1795

DATE: 6-17-08

SHEET 4

A-2

OF 8