

**DAMMON**  
ENGINEERING, INC.

CHIEF ENGINEER  
EMMETT  
DAMMON, P.E.

CHIEF ARCHITECT  
ROBERT  
WILTSE

1095 FLORIDA AVENUE  
SLIDELL, LA. 70458  
OFFICE: 985-649-5832  
FAX: 985-641-5950

WEBSITE:  
WWW.DAMMONENGINEERING.COM

EMAIL:  
DAMMONENG@BELLSOUTH.NET

ARCHITECTURE  
ENGINEERING  
STUDIES  
PLANNING  
INVESTIGATION  
EXPERT WITNESS

NEW  
CHURCH

TABERNACLE  
BAPTIST CHURCH  
2445 FOURTH AVE.  
SLIDELL, LA

SITE  
UTILITIES &  
ILLUMINATION  
PLAN

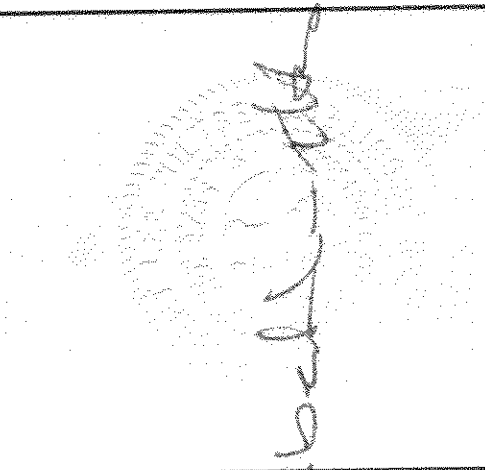

REV: *William D. Jones*

SCALE: AS NOTED

JOB#: 2050

DATE: 2-8-10

SHEET 5

C-4

OF 25

**LEGEND**

- - - - - PROPERTY LINE
- - - - - BUILDING SETBACK
- - - - - LANDSCAPING SETBACK MINIMUM AND BUFFER ZONE LIMITS AT REAR
- NEW BUILDING OUTLINE
- W — NEW WATER LINE
- S — NEW SEWER LINE
- E — NEW POWER LINE
- - - - - NEW DRAIN LINE

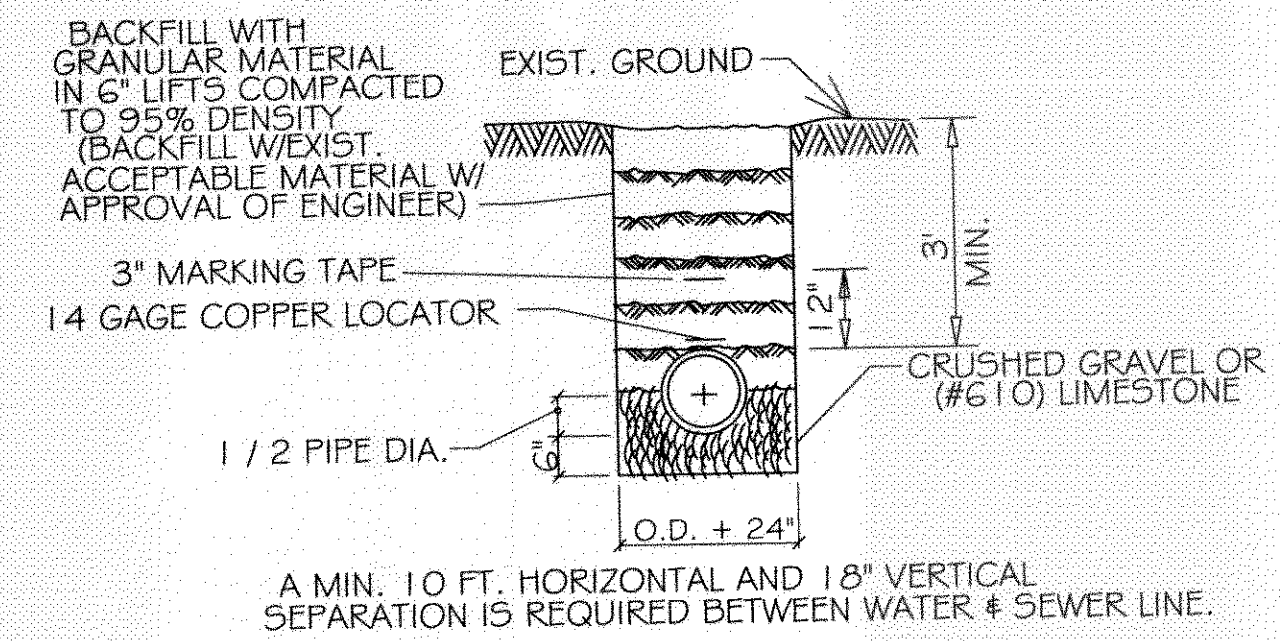

**PIPE BEDDING DETAIL**  
**FOR SEWER & WATER LINE**  
N.T.S.

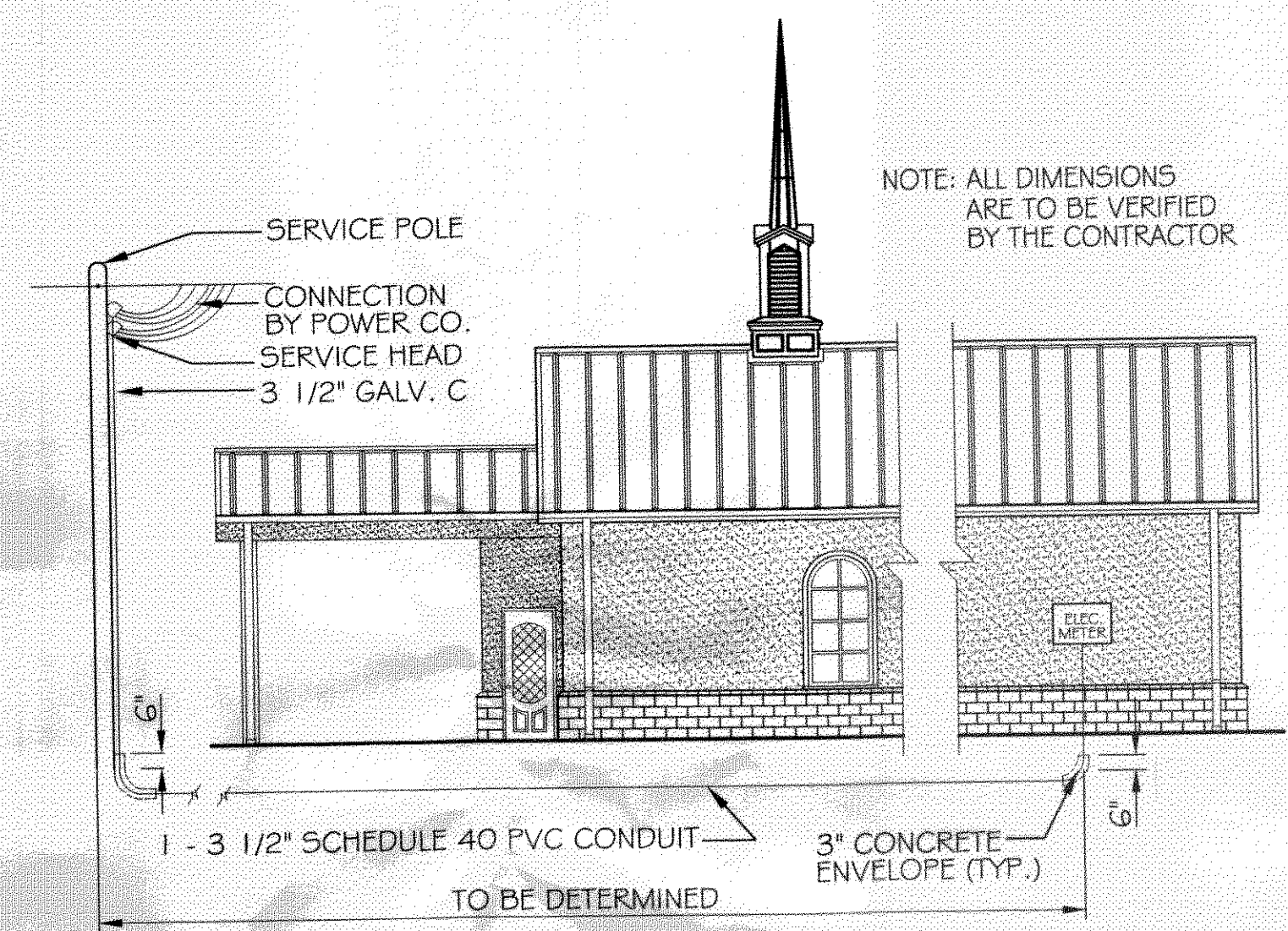

**ELECTRICAL SERVICE DETAIL**  
NTS

376923  
REVIEWED FOR  
STATE FIRE MARSHAL  
AS PER REVIEW LETTER  
BY: WILLIAM D. JONES, ARCHITECT, CBO  
*William D. Jones*

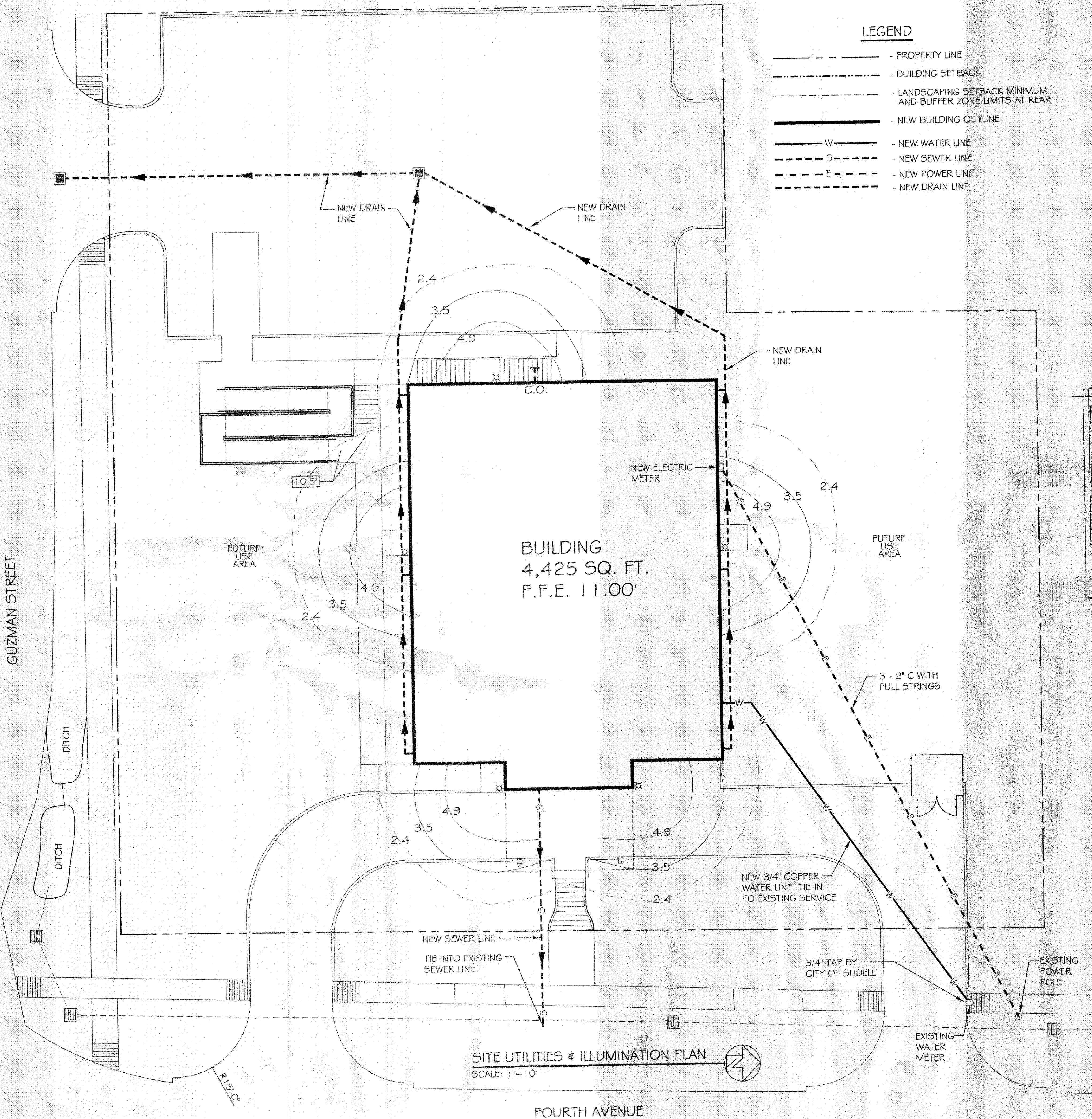

**SITE UTILITIES & ILLUMINATION PLAN**  
SCALE: 1"=10'