

- LEGEND:**
- - - - - PROPERTY LINE
 - - - - - UTILITY / EASEMENT LINE
 - - - - - BUILDING SETBACK MINIMUM
 - - - - - LANDSCAPING SETBACK MINIMUM
 - - - - - NEW BUILDING
 - - - - - NEW DRAIN LINE
 - - - - - NEW DRAIN INLET W/TEMP. SILT FENCING
 - - - - - SLOPE LINES
 - - - - - T.O. GRATE ELEVATION
 - - - - - INVERT ELEVATION
 - - - - - NEW ELEVATIONS
 - - - - - TOP OF CURB ELEVATIONS
 - - - - - T.O. GRATE ELEVATIONS
 - - - - - EXISTING ELEVATIONS
 - - - - - TEMPORARY SILT FENCING

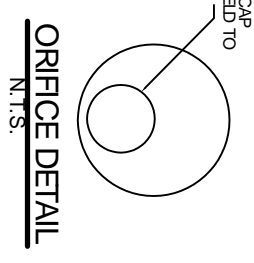

- NOTES:**
- 1) DRAIN PIPE & FITTINGS WITHIN PROPERTY LINE SHALL BE POLYVINYL CHLORIDE PLASTIC PIPE, MEETING CLASS 100 C-900 PVC.
 - 2) ELEVATIONS SHOWN ARE M.S.L.
 - 3) FIELD VERIFY ALL ELEVATIONS AND DRAINAGE SYSTEM PLACEMENT PRIOR TO START OF WORK.
 - 4) MUCK OUT FOR FOUNDATION PAD TO UNDISTURBED SOIL CAPABLE OF 1500 PSF BEARING.
 - 5) DOWN SPOUTS SHALL FLOW INTO SUB-SURFACE DRAINAGE PROPERTY. NEW DRAINAGE CALCULATIONS ARE DETERMINED ACCORDINGLY.

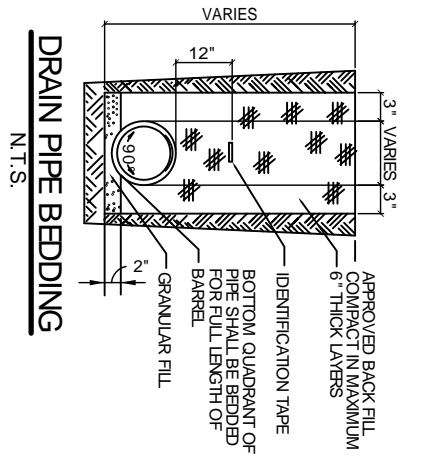
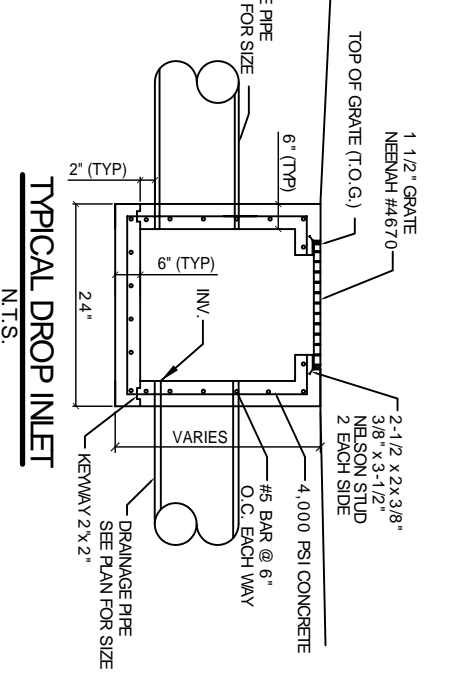
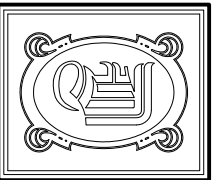

DAMMON ENGINEERING, INC.
 CHIEF ENGINEER
 BIMMET
 DAMMON, P.E.
 CHIEF ARCHITECT
 ROBERT
 WILTSE

1095 FLORIDA AVENUE
 SLIDELL, LA, 70458
 OFFICE 985-649-5832
 FAX 985-641-5950

WWW.DAMMONENGINEERING.COM
 EMAIL: DAMMONENG@BELLSOUTH.NET

ARCHITECTURE
 ENGINEERING
 STUDIES
 PLANNING
 INVESTIGATION
 EXPERT WITNESS

NEW CHURCH

TABERNACLE
 BAPTIST CHURCH
 2445 FOURTH ST.
 SLIDELL, LA

SITE DRAINAGE PLAN

REV: 4-21-10

SCALE: AS NOTED

JOB#: 2050

DATE: 2-8-10

SHEET 6

OF 25

C-5