

DISCOVER THE ADVANTAGES OF FABRIC DUCT VENTILATION



DUCTSOX[®]
Fabric Air Dispersion Products

DuctSox[®] Fabric Duct Ventilation

DuctSox Systems

are an attractive and cost effective replacement for exposed metal HVAC ductwork and diffusers. Constructed of fabric, systems are available in round or surface mount shapes for horizontal or vertical orientations – and in a large variety of fabric types, ranging from our antimicrobial treated Coronado and Sedona-Xm fabrics to our new economy grade EkoTex.

Different than conventional metal, fabric products are engineered and manufactured for each project. DuctSox designs can be simple straight systems or very intricate layouts; incorporating fittings such as radius elbows, T's, transitions or any combination. Sections are zippered together to form extended lengths with diameters from 6 to 80 inches.

Whether industrial, retail, education, commercial, government, warehousing, laboratory, food processing – temporary or permanent – if it's an open ceiling or finished – DuctSox offers a proven choice.

DuctSox Corporation

DuctSox products have been accepted within key industry organizations such as ASHRAE, Underwriter's Laboratories (U.S. & Canada), International Code Council, and by many local building authorities throughout the world.

To maintain market leadership, DuctSox strives to offer the best products, designs and sales support in our industry.

DuctSox corporate goals include developing and maintaining a global distribution and manufacturing strategy as well as developing innovative products while providing customer solutions.

If you'd like to learn more about our DuctSox products - or view photos of installations throughout the world, visit www.ductsox.com.



DuctSox products have evolved through the experience gained from thousands of applications throughout the world.

To better support our Global Distribution Network, we have expanded our production capabilities to Kunshan, China



Fabric Advantages & Benefits

Superior Air Dispersion

In open ceiling architecture, traditional metal duct systems discharge air through side mounted metal diffusers usually spaced 10 to 15 feet apart. The air is directed to specific zones resulting in less efficient mixing of air in the occupied space and often causing drafting and hot or cold spots.

Better air dispersion means better air mixing. Extremely high entrainment ratios result in consistent throw performance for orifices or linear vents. Conventional systems with high volume diffusers result in significant differences from heating to cooling due to the weight, buoyancy and volume of air being dispersed.

With a DuctSox System, the air is discharged more uniformly along the entire length of the DuctSox System providing consistent and uniform air dispersion in the occupied space.

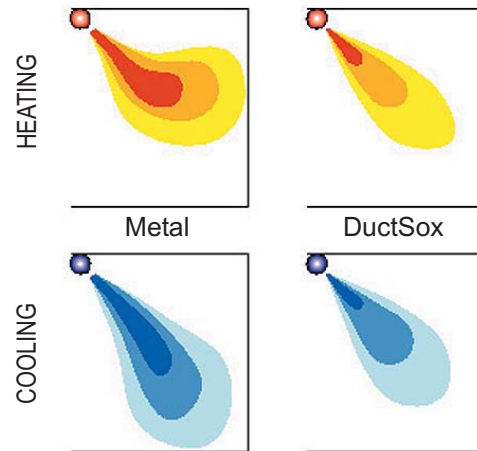
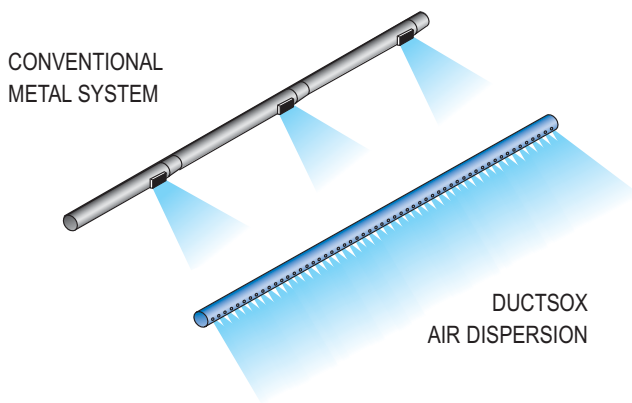

Simplified Design

means less ductwork! Because the entire DuctSox System is a diffuser, air can be discharged over the occupied space in a more efficient pattern as seen in this comparison layout. DuctSox Systems may be designed with fittings similar to metal duct work, including many standard zippered fittings and unlimited customization to match any application requirements.

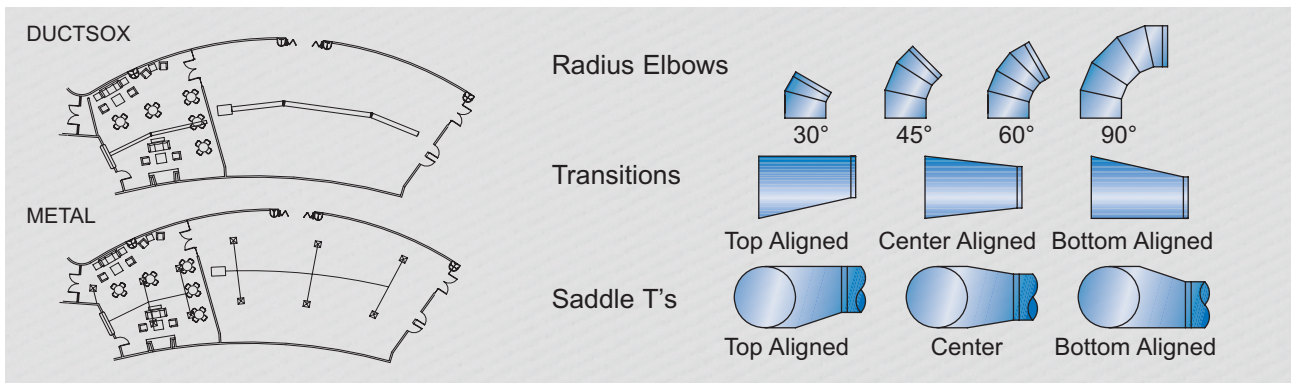

Flow Control AFD™

Airflow control is critical in HVAC air dispersion. The zip-in Adjustable Flow Device (AFD™) offers variable resistance to balance static regain, balance airflow to branches, reduce turbulence and reduce abrupt start ups. Standard for all Coronado, Sedona-Xm and TufTex systems.



Fabric Features, Advantages and Benefits

Cost of DuctSox is 20-80% Less than Metal

- The savings is in the labor time required to install DuctSox versus a comparable metal system. It may require ten times more labor (man hours) to install metal.
- Savings increases with diameter. Unlike metal, the labor time required to install a 60" diameter DuctSox is nearly the same as a 20" diameter.
- The cost savings of air porous DuctSox are even more dramatic when compared to double wall spiral metal, or premium materials; aluminum, stainless or PVC coated.
- The cost of metal has proven to be unstable in today's world economy.

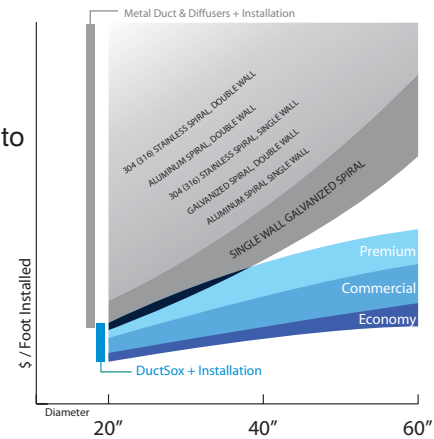

Simple and Easy Installation

Three simple steps to install a DuctSox System can save up to 90% labor time compared to metal.

First, the suspension system is installed using either a simple wire cable or aluminum track system.

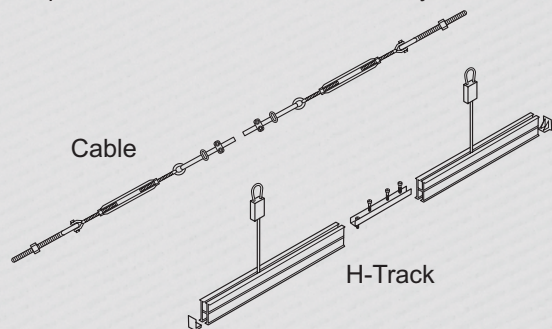

Second, connect zippered DuctSox to the suspension system with one of these four attachment options.



Third, connect and fasten the DuctSox inlet to the starting collar using a DuctBelt and Anchors.

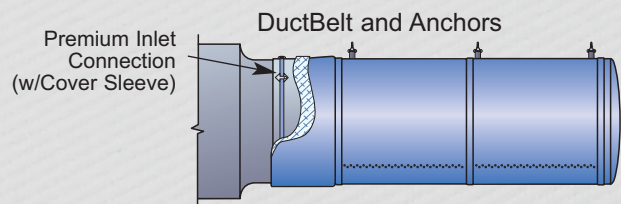

Lighter Weight

The weight of a DuctSox System can be significantly less than a comparable metal system. Designing with DuctSox Systems means lighter roof loads, ease of handling and reduced need for power lifting equipment.

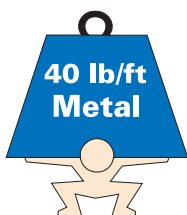

A 60" spiral metal duct weighs 40 lbs./ft. (18 gauge, single wall)



A 60" DuctSox weighs under 2 lb./ft.

Properly Balanced

DuctSox Systems are custom designed and require little if any balancing.

Easy Shipping

DuctSox can be packaged and shipped to your location from any of our manufacturing facilities.



Smaller and lighter packages reduce transportation costs and damage. Available overnight delivery significantly reduces overseas shipping time and costs.

A Lifetime of Carefree Ownership

Lifetime Maintenance

Whether your air delivery system is fabric or metal it will require cleaning sometime over its useful life. Because a DuctSox System can be cleaned inexpensively, it allows the owner to clean a DuctSox more frequently than a metal system. Cleaning metal duct work can be expensive and those costs are often overlooked. Consider that a metal duct system needs to be cleaned inside and out!

A dirty duct (interior) can be a leading contributor to sick building syndrome and human health problems. To maintain Indoor Air Quality (IAQ), the inside surfaces of metal duct require cleaning by a qualified duct cleaning service which can be very expensive, and cleaning the outside surfaces of metal duct work can be even more expensive. In public spaces, it is not unusual that metal duct requires external surface work to maintain aesthetics and cleanliness. The costs of labor, materials, scaffolding and possible business interruption often exceeds the initial investment cost of the duct work. Not to mention that metal is sensitive to moisture from condensation, humidity and leaky roofs, high saline air content, chlorine and other hostile gases and chemicals that cause corrosion and premature deterioration to metal and finished surfaces.



Easy to Clean

When it comes time to clean your DuctSox System, it can be easily removed and laundered. The cleaning process can involve either vacuum cleaning and/or hand or machine washing depending on the fabric. DuctSox Systems are designed with zippered sections for ease of handling and are sized to fit into industrial washing machines.

Hygienic

DuctSox woven fabrics do not absorb moisture, which can be a source for development of bacteria and mold. DuctSox hygienic nature provides resistance to fabric deterioration and breakdown extending life and minimizing maintenance.



Silk Screening

Utilize DuctSox space to advertise your company or school logos, mascots, inspirational sayings, sponsors or suppliers.

Portable

Lightweight, flexible, simple and easy installation/removal enables DuctSox Systems to be re-located between multiple sites. Ideal for temporary use facilities such as large banquet tents, tunneling projects or most any application where part time air ventilation is required.



Flexible

DuctSox fabrics will not dent or scratch like metal duct work. Damage from moving objects like volleyballs and basketballs is eliminated.

Air Porous Fabrics Breathe

Air passing through the fabric eliminates the risk of condensation and deflects air borne dust from accumulating on DuctSox surfaces.

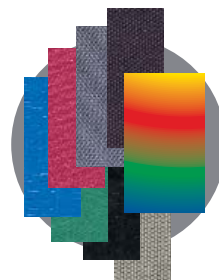
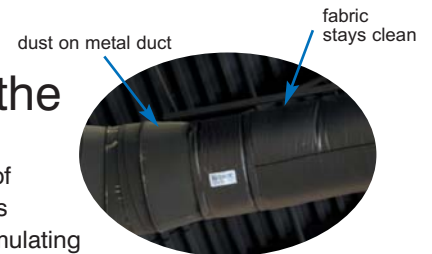

Colorful

DuctSox Systems can be aesthetically pleasing to the eye. DuctSox fabrics are available in a variety of standard colors including custom dyed to match any interior decor. High performance dyes inhibit damage from ultraviolet light and chlorination found in swimming pool environments.

Quiet Air Delivery

With a properly designed DuctSox System, air is delivered quietly and without the resonating properties found in metal. Additionally, DuctSox fabrics provide noise absorption benefits in the occupied space.

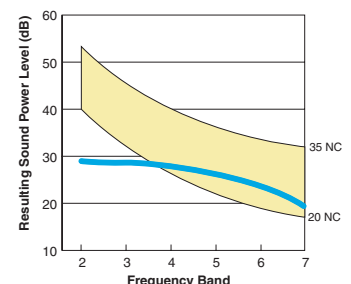

Installation Showcase



Wal-Mart's Experimental Supercenter, in McKinney, Texas, challenged some of the nation's best engineers to produce state-of-the-art innovations in creating perhaps the most environmentally friendly and energy efficient retail store on the planet. While many products are being evaluated – the USA-made fabric DuctSox® system was identified to offer the best return. This return came in reduced construction costs due to easier installation and material cost – plus a residual energy savings.

The DuctSox system design utilizes a low placement – low velocity ventilation concept to evenly disperse the heated and cooled air to the area where it's most needed. While typical Wal-Mart HVAC systems in southern states require 450 tons of cooling with metal duct and diffusers mounted near the ceiling, the McKinney store requires only a mere 380 tons. According to designers – this yields 600,000 kWh of electricity per year, which in comparison is enough power to supply 60 single family homes for an entire year.

Offices



Gyms / Fitness



Retail



“Not having to use paint, adhesives, sealants, and other processes associated with metal duct that introduce pollutants to your air distribution system will always be a green factor.”

Stephen Wagner
Mechanical Engineering & Construction Inc.
Baltimore, MD





Manufacturing / Warehousing





"Once other engineers realize fabric duct's value in a project such as this, I think you'll be seeing a lot of other industrial plants adding these types of cooling and IAQ benefits for employees."

Phil Fina, Quad Graphics, Saratoga Springs, NY

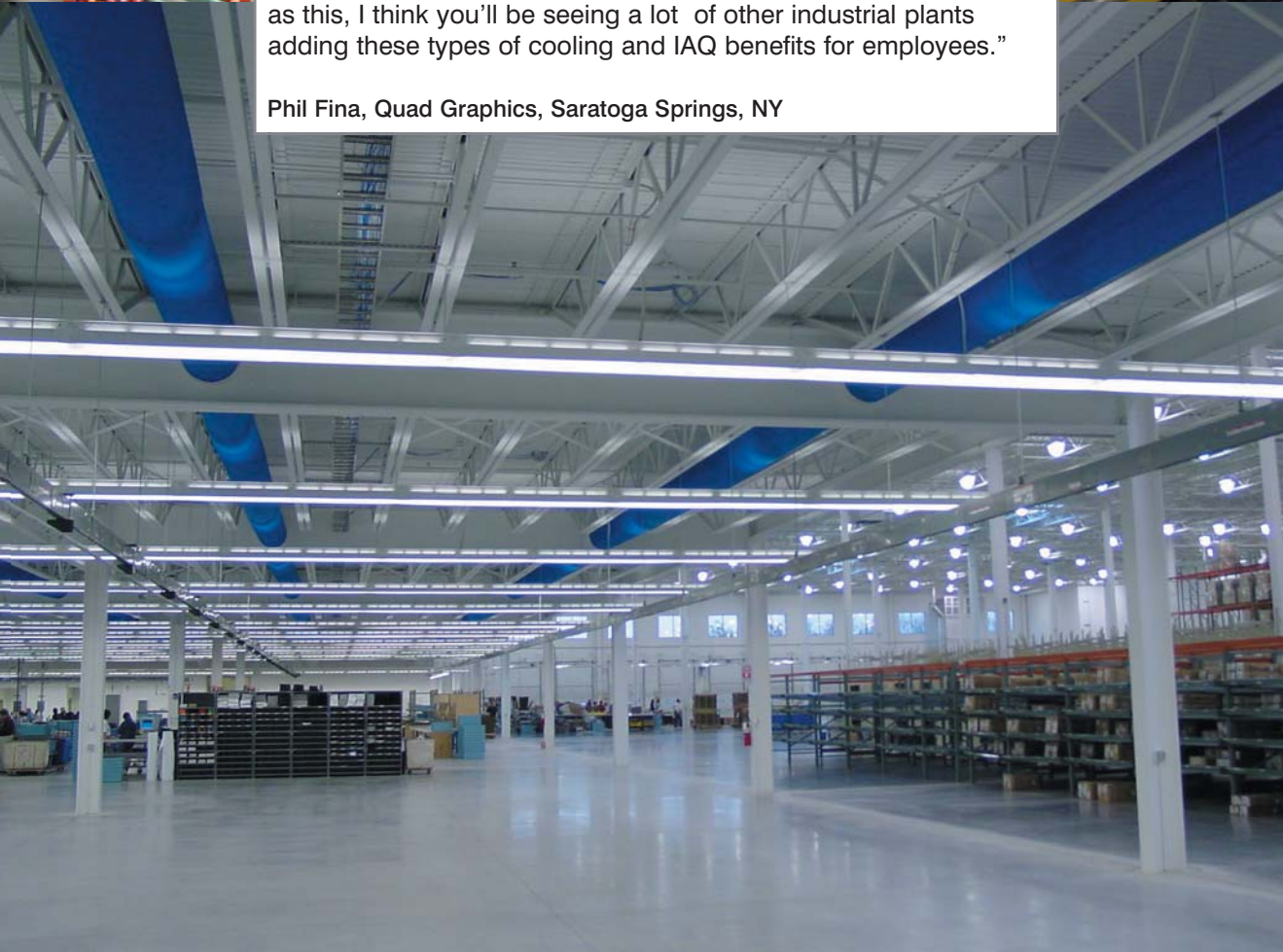

Pools / Waterparks

"We're really pleased how it performs and looks, especially the custom earth tone color that coordinates with the rest of the space. It's designed to resist corrosion so it's really a good choice for this type of space."

Raymond E. Bolton, AIA, Principal
Architectural Design Consultants, Inc.
Lake Delton, WI



Selecting a System

A DuctSox System is made up of four parts.

Series: Defines the cross sectional shape.

Fabric: Defines material and construction.

Model: Describes how the air is dispersed.

Suspension: Includes support and attachment components.

To begin the DuctSox Section process follow these four steps and recommendations on the following page.

1. SELECT THE SERIES OF DUCTSOX - Our standard DuctSox are cylindrically shaped and are intended to be suspended and exposed in open ceiling architecture. It is the Series of choice when there is sufficient ceiling height and clearance from obstructions. The Surface Mount Series can be either half round (D-Shape) or quarter round shaped and are intended to be flush mounted to finished wall and ceiling applications, most common where ceiling height is less than 14'.

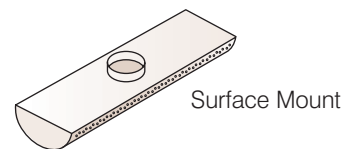
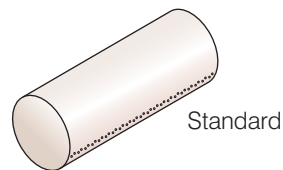

2. SELECT THE PROPER MODEL - There are three standard models of DuctSox that define how the air is delivered.

Comfort-Flow: Air is delivered through linear vents providing a gentle linear air flow. Typical applications are high occupancy spaces where emphasis is on optimum air diffusion and mixing, creating comfortable and pleasing environments.

High-Throw: Air is delivered through orifices providing extended distance and jet-type air flow. Typical environments are low occupancy spaces, but can include high occupancy environments if careful consideration is given to factors that affect comfort.

Low-Throw: Air is delivered through porous fabric resulting in reduced air velocities of less than 30 FPM at the DuctSox surface. Low-Throw is ideal for food processing environments where elimination of drafts, uniform air distribution, and secondary air filtration are required.

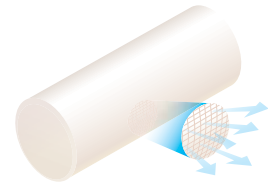
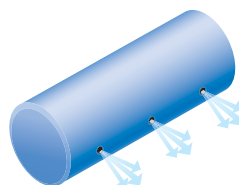
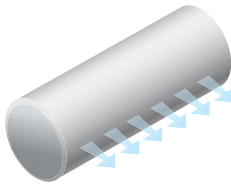

3. SELECT THE PROPER FABRIC - Choose from seven fabrics; Coronado, Sedona-Xm, TufTex, Verona, DuraTex, Microbe-X, Stat-X and EkoTex. DuctSox fabrics were developed to satisfy application requirements in the industrial, retail and commercial markets including telecommunications and food processing. The fabric selected determines the craftsmanship and construction of the DuctSox System. Each fabric is inherently different in terms of aesthetics, color options, weight, porosity, strength, durability, launderability, and may possess special features such as anti-microbial or antistatic properties. It is therefore important to match the fabric features with the application requirements. For example, if condensation is an issue, an air porous fabric would be required. Likewise, it is a good idea to match industrial fabrics with industrial applications and aesthetically appealing fabrics to retail and commercial applications.

4. SELECT THE PROPER SUSPENSION SYSTEM - The last step is to select the suspension system. Suspension options range from simple Tension Cable (galvanized or stainless steel) and three track configurations; two anodized aluminum options (Suspended H-Track and Flush Mount) and one Stainless Steel system (V-Track). The attachment options are either Snap Clips, 3x1 Hangers, Snap Tabs or Cord-In. Selecting the right suspension is based on architectural appeal, economy and the availability of suspension options with the selected fabric.

DuctSox Design Note:

See the DuctSox Design Manual to determine air flow design incorporating vent and orifice sizing, fabric porosity selection, DuctSox lengths and diameters, air flow orientation and throw, etc. For a copy of the Design Manual visit our web site at www.ductsox.com or contact DuctSox at (866)-DUCTSOX (382-8769).

Recommendations

Application	Model Options*	Fabric Options	Suspension & Attachment Options
Food Processing	LT, CF	Microbe-X	Stainless Steel Cable and Snap Clips
Industrial, Manufacturing, Warehousing and Distribution	HT, CF	Sedona-Xm, TufTex, Verona, DuraTex EkoTex up to 32" dia.	Tension Cable: Snap Clips or 3x1 Hangers Aluminum Track and Snap Tabs
Pools	CF	Coronado, Sedona-Xm, Verona, TufTex, DuraTex	Tension Cable: Snap Clips Aluminum Track: Snap Tabs or Cord-In
Gymnasium	HT, CF	Coronado, Sedona-Xm, Verona, TufTex, DuraTex	Tension Cable: Snap Clips or 3x1 Hangers Aluminum Track and Snap Tabs
Office Space, Telemarketing	CF, HT	Coronado, Sedona-Xm, Verona, TufTex, DuraTex	Tension Cable: Snap Clips or 3x1 Hangers Aluminum Track: Snap Tabs or Cord-In
Retail-Grocery Store	CF, HT	Coronado, Sedona-Xm, Verona, TufTex DuraTex	Tension Cable: Snap Clips or 3x1 Hangers Aluminum Track: Snap Tabs or Cord-In
Restaurant, Bar, Cafeteria	CF, HT	Coronado, Sedona-Xm, Verona, TufTex	Tension Cable: Snap Clips or 3x1 Hangers Aluminum Track: Snap Tabs or Cord-In
Library, School Classroom	CF, HT	Coronado, Sedona-Xm, Verona, TufTex	Tension Cable: Snap Clips or 3x1 Hangers Aluminum Track: Snap Tabs or Cord-In
Telecommunication & Electronics Hub	CF	Stat-X	Tension Cable: Snap Clips or 3x1 Hangers
Auditorium, Sports Arena, Convention Center, Church	HT, CF	Coronado, Sedona-Xm, Verona, TufTex	Tension Cable: Snap Clips or 3x1 Hangers Aluminum Track: Snap Tabs or Cord-In
Tent, Temporary Structure, Animal Housing	HT	DuraTex up to 48" dia. EkoTex up to 32" dia.	Tension Cable: Snap Clips
Clean Room, Test Lab	LT, CF LF, RF	Microbe-X, Stat-X, Rx200 or Rx100	Galvanized Cable and Snap Clips D-Fuser or Surface Mount

Model, fabric and suspension recommendations are based on DuctSox experience.

***CF**=Comfort-Flow, **LT**=Low-Throw, **HT**=High-Throw

LF=Lami-Flow, **RF**=Radial Flow

DESIGNER

Coronado™

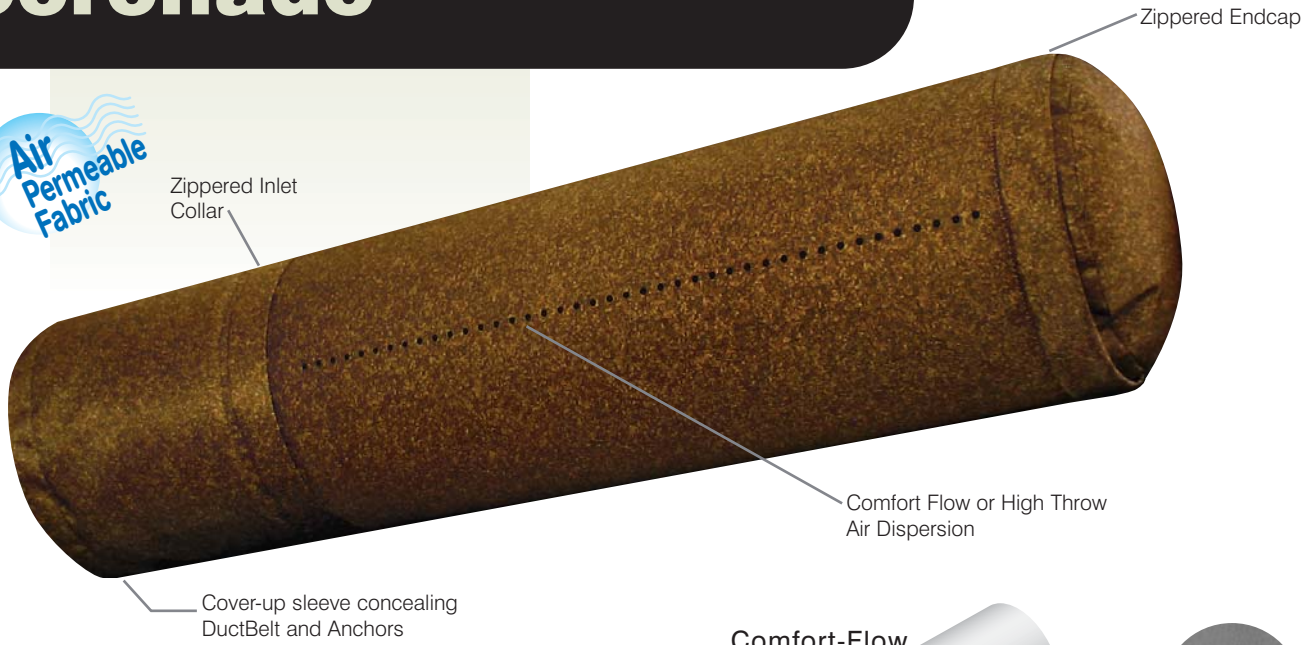

Fabric: Coronado™ features our new designer patterns while offering an --active antimicrobial agent and a matte fabric finish. This new fabric is available in four standard patterns plus custom patterns. Construction features finished seams, positive inlet anchoring system with cover-up sleeve, zippered endcaps and a zippered inlet collar for a DuctSox Final Filter or Adjustable Flow Device. Coronado fabric is air permeable, machine washable and available with all suspension systems.

Application: Coronado is a colorful designer fabric that is ideal for any aesthetically attractive environment. Common uses include retail, commercial, high end residential, and community applications. Ideal if condensation is a concern.

Specifications:

Fabric: FR Polyester Twill
Biocide: 1,400 ppm, effective to 10 wash cycles
Weight: 6.75 oz/yd²
Porosity: 1.5 CFM/ft² at 0.5" w.g.
Codes: UL Classified (ICC-AC167)

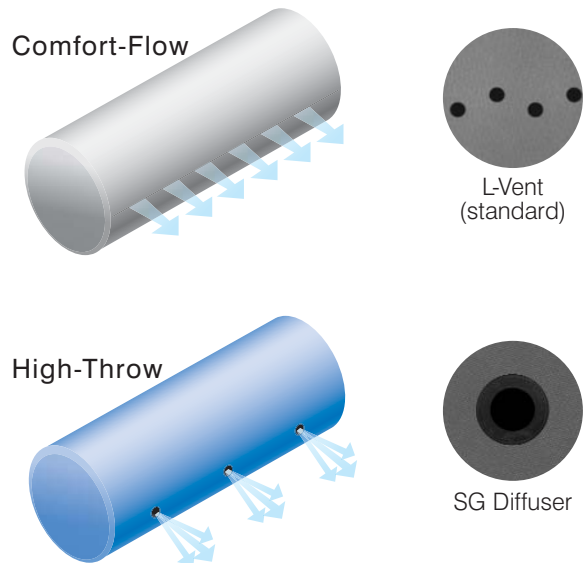

Pattern Options

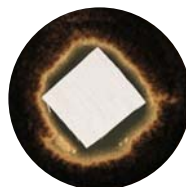
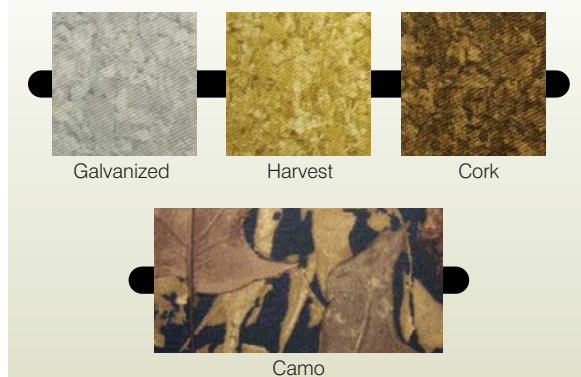

Independent antimicrobial testing reveals a distinct zone of inhibition around the Sedona-Xm fabric swatch. Even after laundered (10x), tested fabric samples continue to yield clear antimicrobial effectiveness.



PREMIUM

Sedona-Xm™

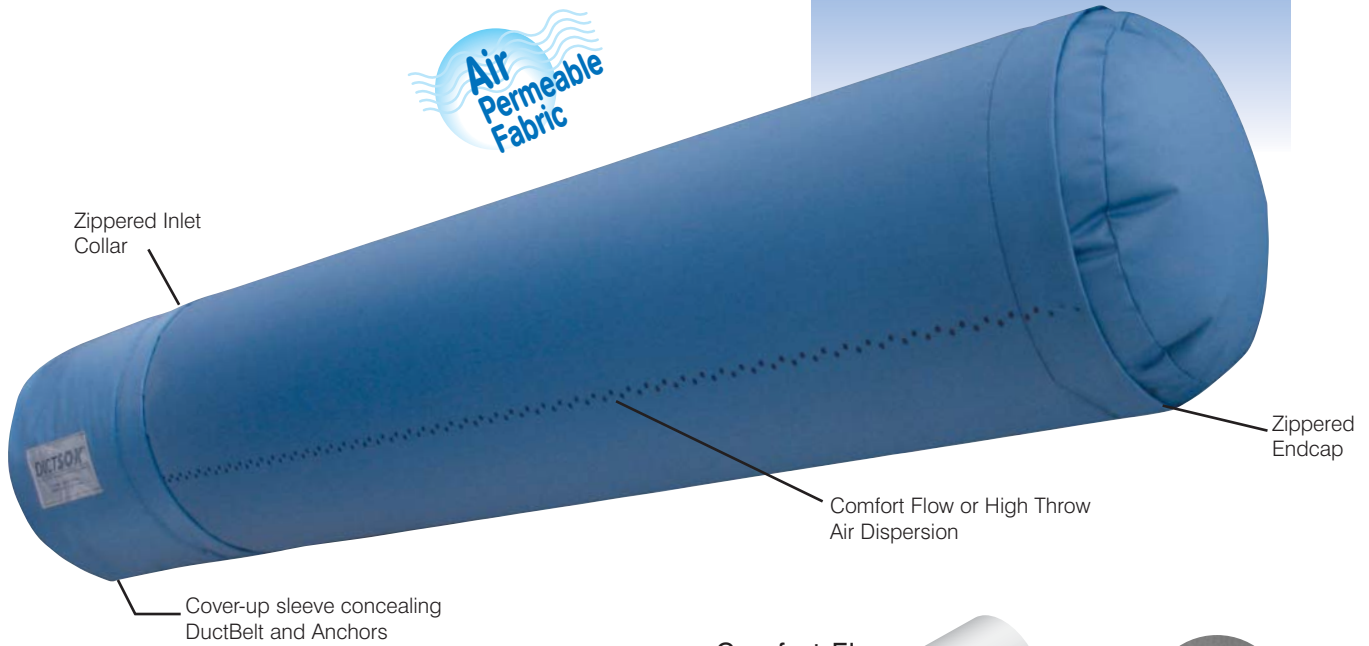

Fabric: Sedona-Xm™ premium grade fabric features an active antimicrobial agent and a matte fabric finish. This fabric is available in seven standard colors plus custom color matching. Construction features finished seams, positive inlet anchoring system with cover-up sleeve, zippered endcaps and a zippered inlet collar for a DuctSox Final Filter or Adjustable Flow Device. Sedona-Xm fabric is air permeable, machine washable and available with all suspension systems.

Application: Sedona-Xm is a colorful premium fabric that is ideal for any aesthetically attractive environment. Common uses include retail, commercial, education, and community applications. Ideal if condensation is a concern.

Specifications:

Fabric: FR Polyester Twill
 Biocide: 1,400 ppm, effective to 10 wash cycles
 Weight: 6.75 oz/yd²
 Porosity: 1.5 CFM/ft² at 0.5" w.g.
 Codes: UL Classified (ICC-AC167)

Comfort-Flow

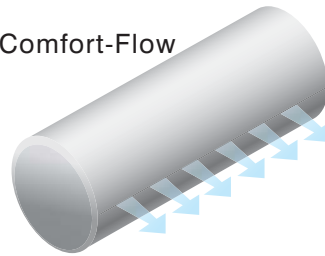

High-Throw



Color Options



Black, Gray, White, Tan, Green, Blue, Red, Custom Colors

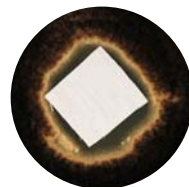

Independent antimicrobial testing reveals a distinct zone of inhibition around the Sedona-Xm fabric swatch. Even after laundered (10x), tested fabric samples continue to yield clear antimicrobial effectiveness.



File R18856

PREMIUM

TufTex™

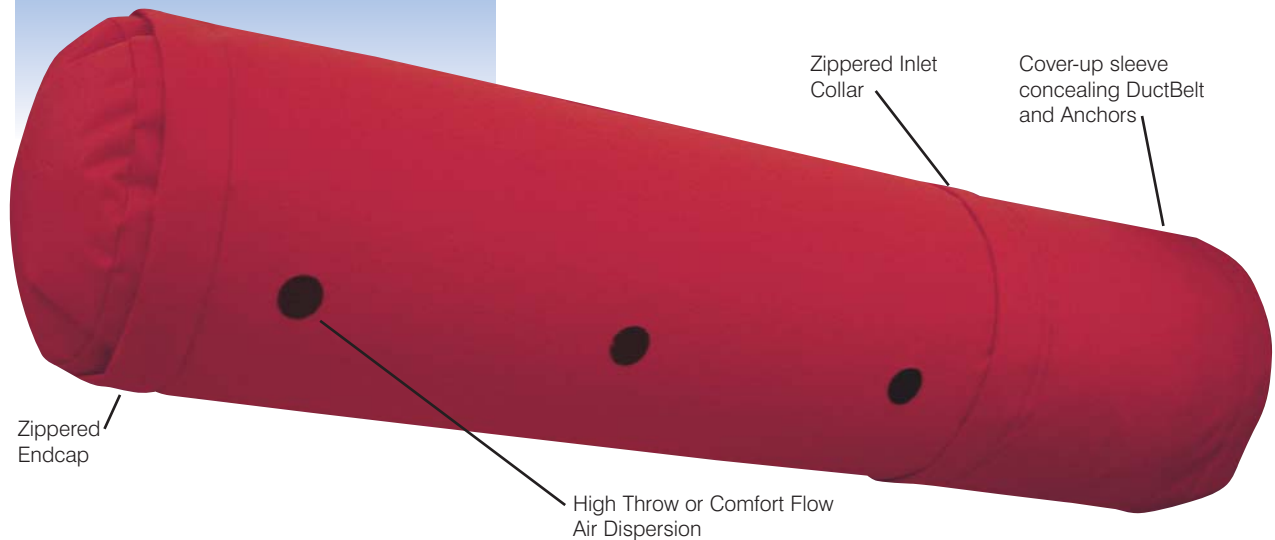

Fabric: TufTex is a heavy-weight premium grade non-permeable polyester fabric. This heavy duty fabric is woven with a textured and aesthetic finish. Construction features finished seams, a positive inlet anchoring system with cover-up sleeve, zippered endcaps and a zippered inlet collar for a DuctSox Final Filter or Adjustable Flow Device. TufTex is machine washable.

Application: TufTex is ideal for heavy-duty industrial applications yet aesthetically attractive for commercial and retail environments. Airflow options include standard High-Throw (orifices only) and all Comfort Flow options. Use where condensation is not an issue.

Specifications:

Fabric: FR Polyester Plain (coated)
Weight: 8.2 oz/yd²
Porosity: none
Codes: UL Classified (ICC-AC167)

High Throw

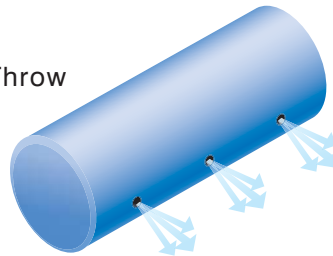

Comfort-Flow

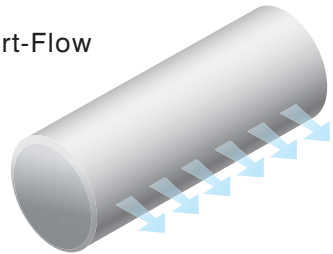

Color Options

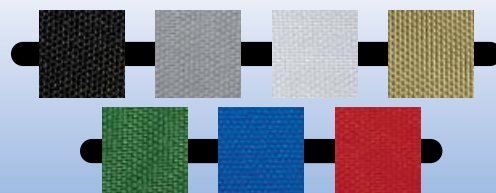

Black, Silver, White, Taupe, Green, Blue, Red



Verona™

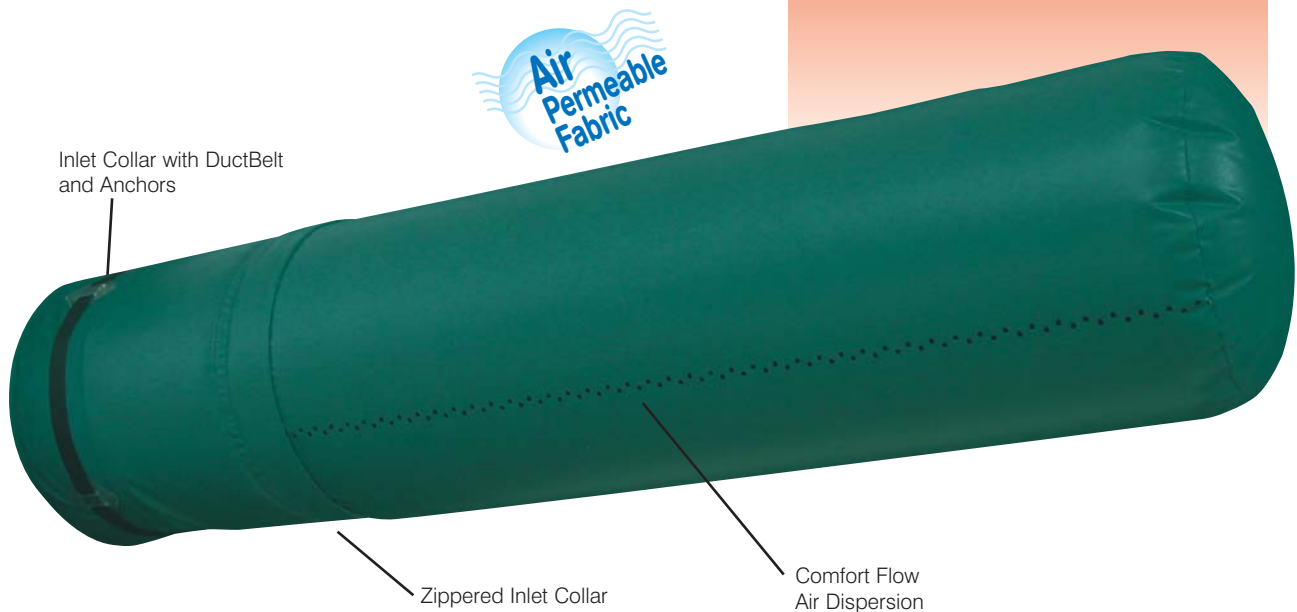

Fabric: The all purpose Verona™ is a woven air permeable commercial grade fabric that offers best-in-class performance and features. Features include finished seam construction, positive inlet anchoring system and a zippered inlet collar for the addition of DuctSox Final Filter or Adjustable Flow Device. Verona comes in seven popular colors; black, gray, white, tan, green, blue, red and custom colors. Verona is machine washable and available with all DuctSox suspension systems.

Application: Ideal for any aesthetically attractive environment. Common uses are in; retail, commercial, education, and community applications. Ideal if condensation is a concern.

Specifications:

Fabric: FR Polyester Twill
 Weight: 5.2 oz/yd²
 Porosity: 1.5 CFM/ft² @ 0.5" w.g.
 Codes: UL Classified (ICC-AC167)

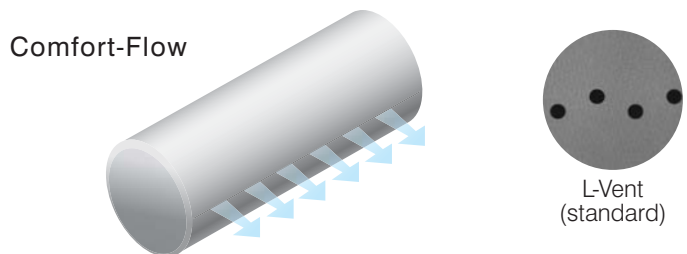

Color Options



File R18856

DuraTex™

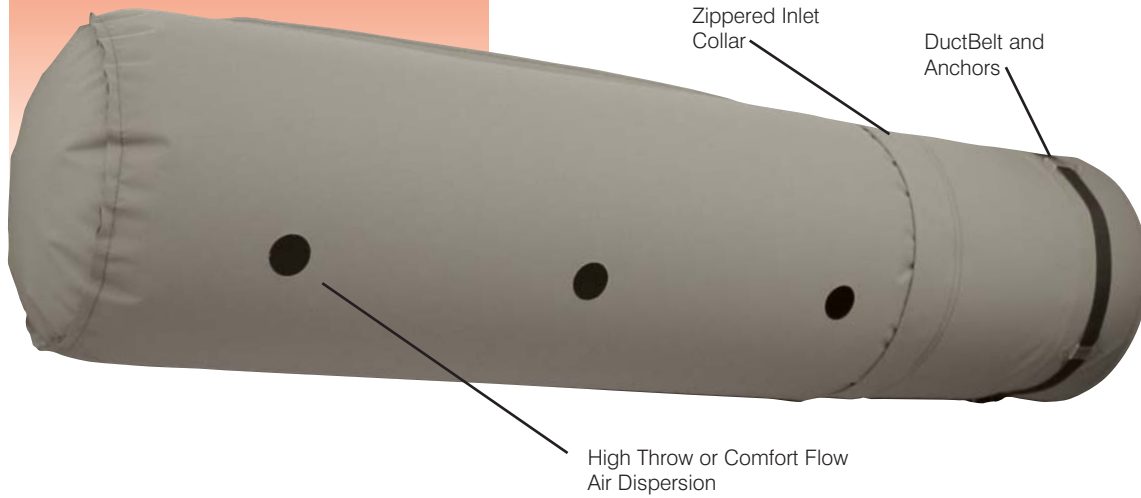

Fabric: DuraTex is a medium weight, commercial grade nonpermeable fabric. Developed as our mid grade polyester based fabric, DuraTex features include an inlet collar with positive inlet anchoring system, zipper inlet collar for the addition of DuctSox Final Filter or Adjustable Flow Device. DuraTex is machine washable and is available with all DuctSox suspension systems. DuraTex is available in five standard colors.

Application: DuraTex is ideal for light retail and industrial applications such as manufacturing, warehousing and distribution.

Specifications:

Fabric: FR Polyester Plain (coated)
Weight: 5.5 oz/yd²
Porosity: none
Codes: UL Classified (ICC-AC167)

High Throw

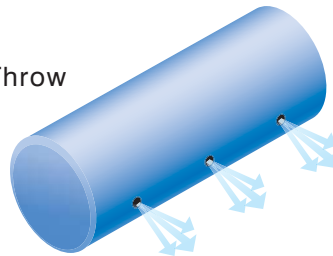

Comfort-Flow

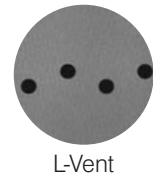
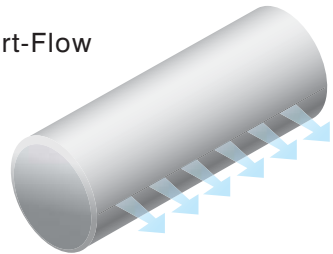

Color Options

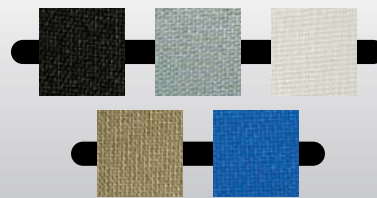

Black, Silver, White, Taupe, Blue

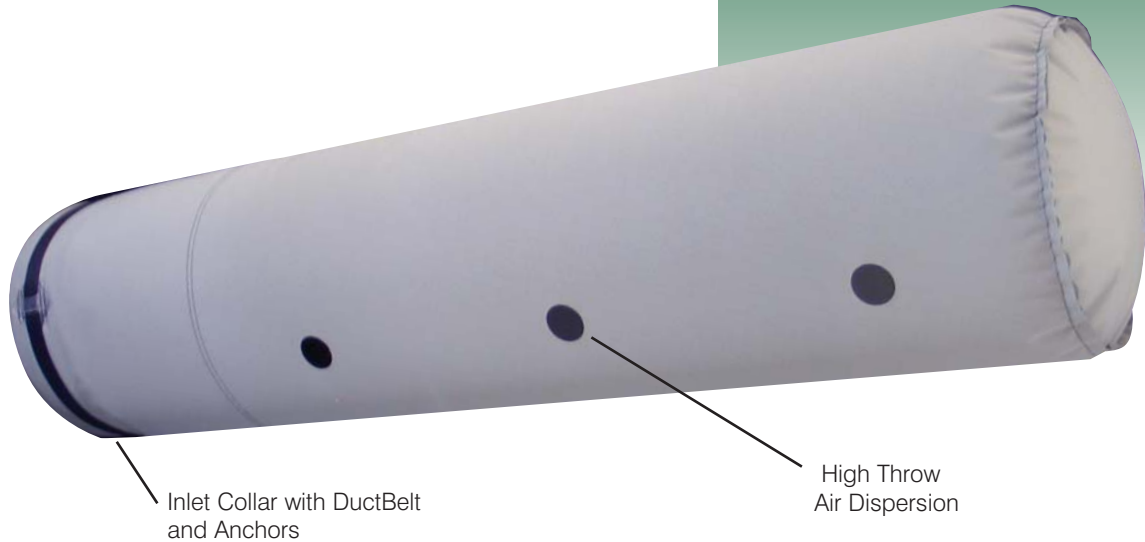

Fabric: EkoTex is a lightweight, non-porous woven and coated polyester material. EkoTex is the most economical DuctSox fabric and features simple construction including an inlet collar with DuctBelt and Buckle. EkoTex is machine washable and is only available in round shape with Tension Cable or Suspended H-Track Suspension.

EkoTex products are available in limited diameters, suspension configurations and air dispersion.

High Throw

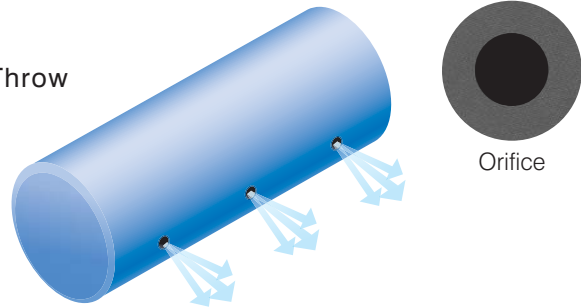

Application: Ideal for light duty and simple designs, including industrial applications such as manufacturing, warehousing and distribution. Other uses are greenhouses and temporary structures.

Specifications:

Fabric: FR Polyester Plain (coated)
Weight: 3.2 oz/yd²
Porosity: none
Codes: UL Classified (NFPA 90-A)

Color Options



File R18856

Microbe-X™



Low Throw or Comfort Flow
Air Dispersion

Heavy-weight Inlet Collar with
DuctBelt and Loops.

Fabric: Developed for food processing applications, Microbe-X fabric offers a lightweight and highly launderable filament fiber construction. The polyester yarns are also treated with a non-leaching antimicrobial – to control the growth and transmission of harmful bacteria, fungi and molds that can be found in food processing environments. Microbe-X is proven to be effective after 100 wash cycles. Construction features finished seams and a heavy weight inlet collar with an integral DuctBelt and attachment loops. Microbe-X is machine washable and available with all DuctSox suspension systems.

Low Throw

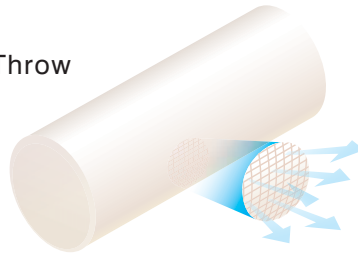

Comfort Flow

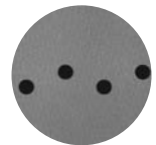
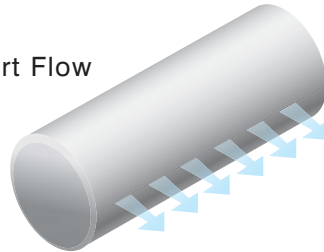

L-Vent
(standard)



Mesh Vent

Application: Ideal for refrigerated/food processing and other applications requiring low velocity air delivery.

Specifications:

Weave: Filament Polyester Weave
Weight: 3.2 oz/yd²
Porosity: 6, 13, 20, 29 CFM
Codes: USDA Approved

Color Options

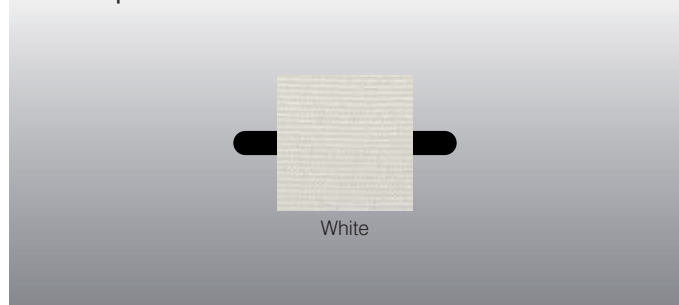

Stat-X™

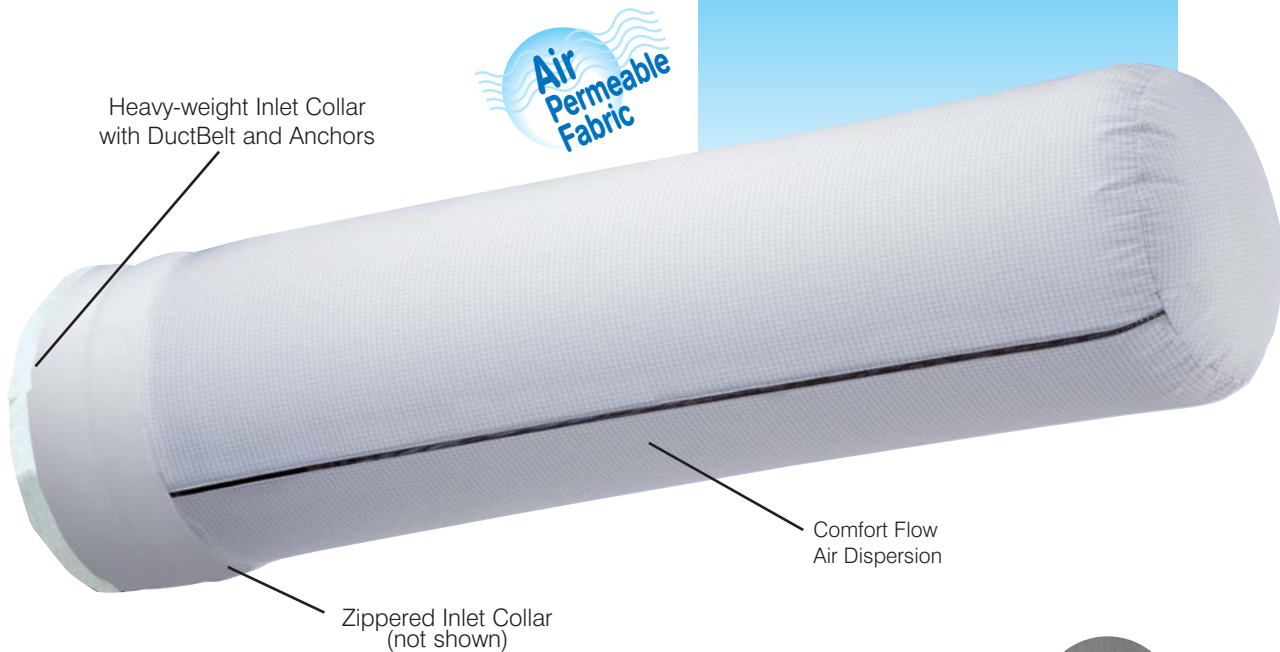

Fabric: Stat-X is an engineered polyester based fabric designed for electrically sensitive environments. Stat-X includes ESD (Electro Static Dissipative) yarns woven in a grid pattern approximately 1/4" x 1/4" to dissipate static buildup. Stat-X is a light weight, air-permeable fabric. Construction features finished seams and a heavy-duty inlet collar with positive inlet anchoring system, zipper inlet collar for the addition of DuctSox Final Filter or Adjustable Flow Device. Stat-X is machine washable and available with all DuctSox suspension systems.

Comfort Flow

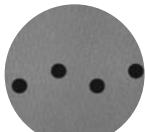
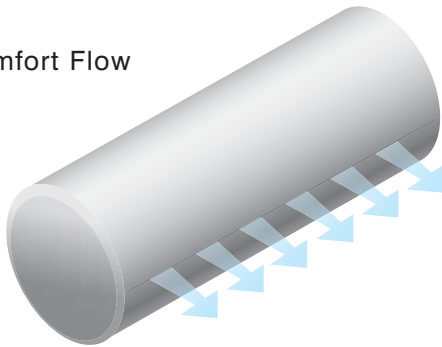

L-Vent (standard)

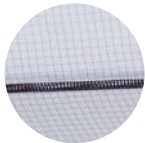

Mesh Vent

Application: Stat-X is ideal for static sensitive environments in the telecommunication and electronics industry.

Specifications:

Weave: FR polyester with interwoven ESD yarns
 Weight: 2.9 oz/yd²
 Porosity: 2.5 CFM/ft² @ 0.5" w.g.
 Codes: UL Classified (ICC-AC167)

Color Options

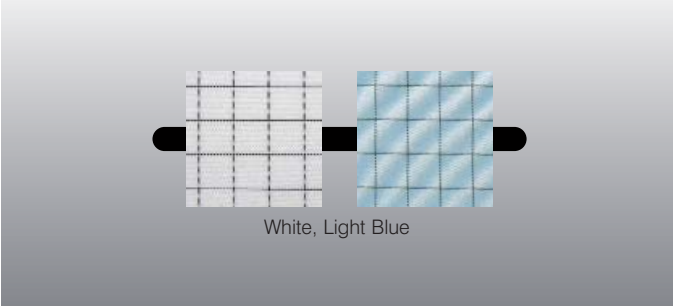

File R18856

LABSOX

Rx100™ & Rx200™

High Permeability Reduces Static Pressure



Custom Venting for Radial or Select Flow

Fabric: Rx fabrics are an engineered polyester based fabric designed for air dispersion in critical environments. Rx filament based fabrics offer a light weight highly permeable textile that features an active antimicrobial treatment and includes up to 50% post industrial recycled content.

Rx fabrics are utilized in the D-Fuser and LabSox products. Finish and assembly construction varies.

Application: Rx fabrics are ideal for critical environments, including laboratories, clean manufacturing, vivariums, educational facilities and more.

Lami-Flow

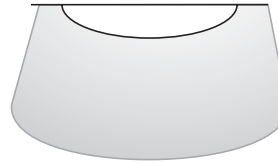

Radial Flow



Select Flow



Specifications:

Weave: Filament FR polyester
Biocide: 1,400 ppm, effective to 10 wash cycles
Recycled: Up to 50% Recycled Content
Weight: Rx100: 5.5 oz/yd²
Rx200: 5.2 oz/yd²
Porosity: Varies by fabric.
Codes: UL Classified (NFPA-90A)

Color Options

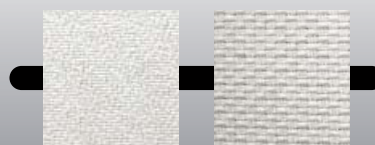

Warranty & Code Compliance

Design & Performance Warranty

For the first year of operation - each DuctSox system designed and operating within the published guidelines is covered by a design and performance warranty. To assist through the design process, we freely offer our published design manual on our website or provide design assistance through our inside sales and engineering group.

DuctSox Product Warranty

The DuctSox Warranty is for replacement or repair credit based on the amount of the warranty period remaining. The warranty is not available in the form of a cash payment, only as credit towards repair or replacement. The DuctSox Warranty covers materials, fabrication and performance of the fabric portion of the DuctSox System only. Warranty coverage begins at time of shipment.

Material	Warranty Period	Application Requirements
Coronado, Sedona-Xm & TufTex	10 year, prorated years 5-10	Airflow & Static Pressure per original DuctSox design in accordance with published requirements at the time of shipment.
Verona, DuraTex & Stat-X	5 year, prorated years 2.5 - 5	Same as above
EkoTex, Rx & Microbe-X	1 year	Same as above



Warranty excludes damage to fabric from improper installation, poor maintenance, abuse, abrasion, caustic chemicals, exposure to high temperature (over 180 degrees F), fabric discoloration and shrinkage or any unauthorized modifications to system. Warranty does not cover any labor, equipment rental or freight charges incurred as a result of executing the warranty.

Code Compliance

As drafted by the International Code Council, (ICC), Acceptance Criteria for Fabric Air Dispersion Systems (AC-167) is the most comprehensive compliance requirement assembled for the fabric duct industry. More than just a measure of safety, quality and performance, when combined with our classification to this standard by Underwriters Laboratories (UL) ensures continued compliance for all marked products. Additional information is available at www.ductsox.com.

Suspension

DuctSox Fabric Ventilation Systems are easily suspended, with an array of convenient installation options that enable simple and flexible integration into a wide range of architectural situations.

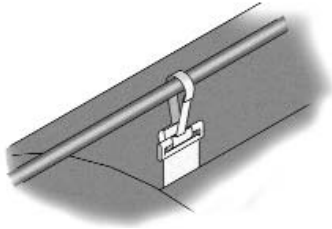

Cable with
Nylon Snap Clip

Tension Cable

Simple tension cable is available for all fabric options and is the most economical option. Available for all sizes - Cable suspension is available for one and two row suspension options (2 row required at 32" diameter and larger). Snap Clips are spaced every 24 inches along the length to ensure proper support. The system consists of a cable, turnbuckle(s) and securing hardware for a simple installation. Cable components available in galvanized, 316 Stainless Steel and plastic coated S/S cable.

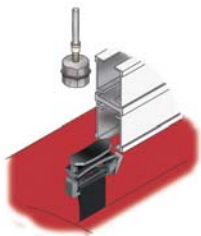

Aluminum H-Track
with Snap Tab

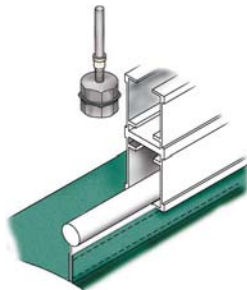

Aluminum
H-Track with
Cord-In

Suspended H-Track

Anodized aluminum track includes an open top and bottom to allow easy location of vertical supports and clear connection to the DuctSox below. H-Track is available for most fabric options. Available for all sizes, H-Track suspension is available for one and two row suspension options (2 row required at 32" diameter and larger) and may include radius sections for elbows. Snap Tabs are spaced every 24 inches along the length to ensure proper support. Cord-In attachment option allows for continuous support for smaller diameter sections. The system consists of 10 foot sections of H-Track, couplers, end caps, locking cable drop supports and Gripple quick connect devices for easy installation. Supporting hardware components are available in galvanized or 316 Stainless Steel.



Aluminum Flush
Mount with
Snap Tab



Aluminum Flush
Mount with
Cord-In

Flush Mount Track

Anodized aluminum track is available for select fabric options and is designed to be affixed to a flat surface using anchors or T-Bar snap clips. Flush Mount Track is available for one row suspension option - and all Surface Mount Models. Snap Tabs are spaced every 24 inches along the length to ensure proper support. Cord-In attachment option allows for continuous support for smaller diameter sections. The system consists of 12 foot sections of Flush Mount Track, couplers, end caps and - if required - T-Bar connection clips for an installation to common T-Bar ceiling.

3x1™ Suspension System

Looks Inflated
Easy Installation
Smoother Start Up

Compare inflate/deflate shapes of each DuctSox suspension system

1 Row

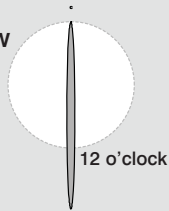

2 Row

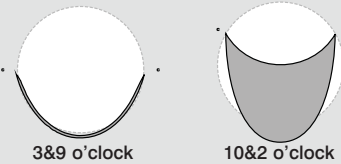

3x1



The 3x1 Suspension System offers a whole new dynamic in fabric duct suspension. The 3x1 system gives your open ceiling the sophistication you've been looking for with style, color and a simpler suspension system, making transitions smoother and less complicated.

By requiring only a single cable, the 3x1 system reduces the number of knee brackets with elbows, T's or transitions - reducing material and labor costs.

- 3x1 hangers attach to tension cable at 12 o'clock
- D-Clasps connect duct at 10&2 to each hanger end
- Snap clips connect to cable between hangers

3x1 Suspension Systems require fewer brackets.

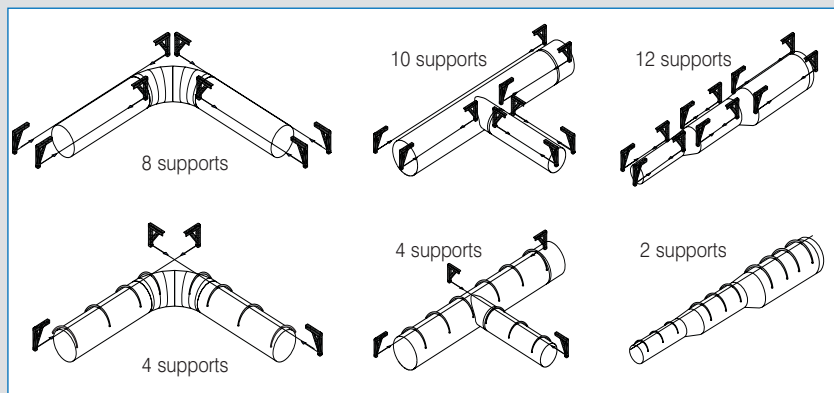

Surface Mount



The Surface Mount DuctSox is ideal for low profile applications where flush mounting to the ceiling and/or wall is required. Applications can vary from environments such as classrooms and laboratories to industrial settings where low ceiling heights are common.

The Surface Mount Series has the same flexible design features as our Standard Series DuctSox Systems including zippered fittings and connections. To eliminate the risk of condensation, the standard fabric is Sedona-Xm. See page 17 for fabric specifications. Anodized aluminum flush mounted tracks are easily anchored to fixed ceiling surfaces or installed to a T-Bar grid system using standard mounting clips provided by DuctSox.

The cord-in feature helps maintain an inflated and pleasing appearance even in the deflate mode. Standard diameters are: 14", 18", 22", 26", 30", and 34". The air inlet to a Surface Mount DuctSox can be either top-down through the ceiling or from the side through the wall.

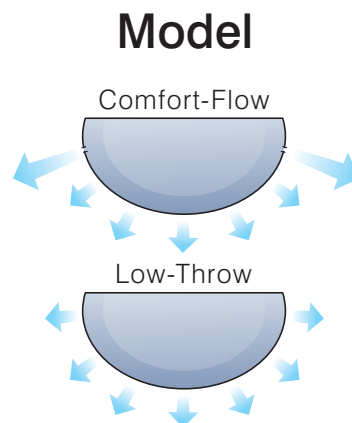

Suspension

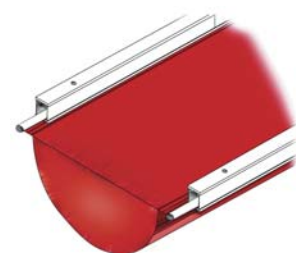

D-Fuser™ *Fabric Faced Diffuser for Critical Environments*

Combining a metal backpan with the airflow and maintenance advantages of a fabric face yields one of the industry's most unique air dispersion devices. In addition to being quiet and lightweight, our D-Fuser™ offers hemispherical air dispersion through its highly porous fabric face and available venting.

- **Configurable Air Dispersion**

Inexpensive and interchangeable fabric face available to change air flow patterns.

- **Lightweight Construction**

10 lbs lighter than standard metal models.

- **Easy Maintenance**

Simply remove the fabric face and launder.

- **Quiet**

Up to 10 dB quieter than standard metal models.

- **Innovative New High Tech Fabrics**

Rx Series fabrics offer antimicrobial treatment, high permeability and up to 50% recycled content.

- **Retrofit**

Improve your existing diffuser by changing its face from metal to fabric.



Smoke Test of Lami-Flow D-Fuser.
Pat. Pending

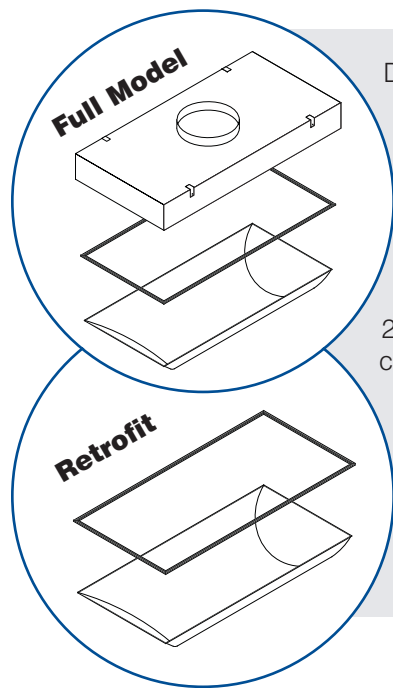

Developed specifically for laboratories, the D-Fuser is available in two models and various configurations. The two models include Full Assembly and Retrofit.

Full Assembly model D-Fuser's consists of three major components: Metal Backpan, Face Frame and Fabric Face. The fabric face protrudes 6-1/2 inches below the ceiling and the assemblies are available in standard sizes of 24x24 and 24x48. To ensure a correct fit, we offer many varieties of component configurations - including a filter option.

Improve air performance of existing diffusers by attaching our retrofit Face Frame and a Fabric Face. Custom components and assembly kits are available to fit backpans of common manufacturers.

The Fabric Face shape and custom venting enables a consistent or a variety of airflow patterns.

Lami-Flow



Delivering 100% of the airflow through the fabric.

Radial Flow

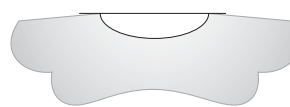

Available in a total of eight configurations, including 1, 2, 3 or 4 way throw.

Select Flow



Offering custom venting for unique airflow patterns.

AFD™ (Adjustable Flow Device)

Designed for new systems - as well as retrofits, the AFD is easily installed or replaced in minutes by zipping or unzipping its collar between duct lengths and is available in 6 inch to 80 inch diameter. Besides benefits of flow control - the AFD also serves as a flow straightener. The AFD will be preset from the factory to the recommended setting per location, and should not require any field balancing unless otherwise noted.

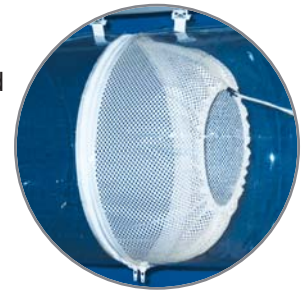

Inlet

- ◀ Balance multiple runs
- ◀ Reduce/eliminate airflow turbulence

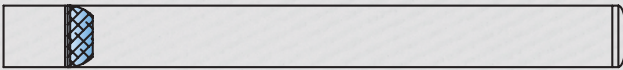

Middle

- ◀ Balance static regain



No-Pop

- ◀ Reduce inflation "pop"

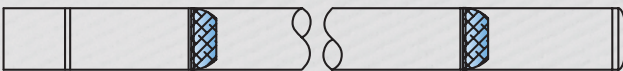

Plenum and Branches

- ◀ Direct airflow into branches and balance static regain

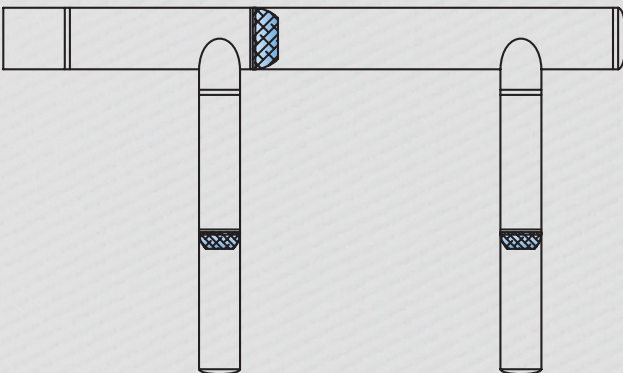

Standard Design/Location:

Inlet

- ◀ Each inlet when multiple inlets connected to a common AHU / fan
- ◀ Any system that has an apparent turbulent inlet configuration

Middle

- ◀ All systems with an intermediate zipper over 40 ft and inlet velocity over 1,400+ CFM

No Pop

- ◀ All systems over 100 ft, & over 5,000 CFM placed within last 30% of run

Plenum

- ◀ After outlet (or outlets within 10 ft) when plenum velocity is 1,200+ FPM

Exceptions

- ◀ Systems should not include more than 2 AFD's in sequence to an endcap

Coronado, Sedona-Xm & TufTex

- ◀ AFD devices included with each system constructed of our Coronado, Sedona-XM and TufTex premium fabrics

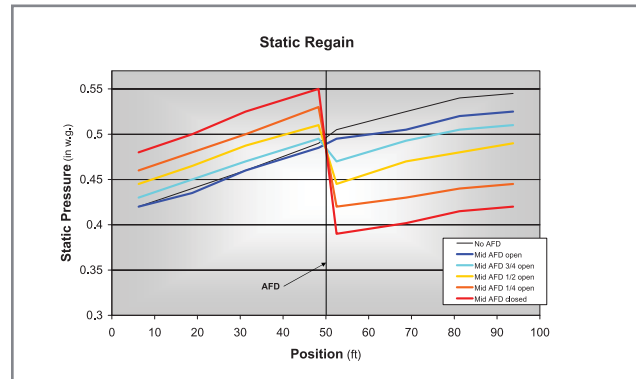
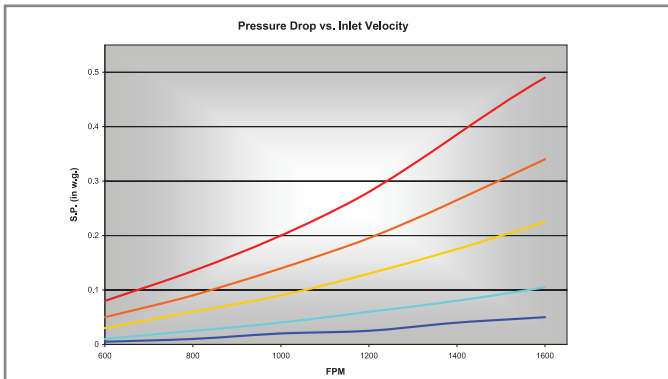

DuctSox Final Filter

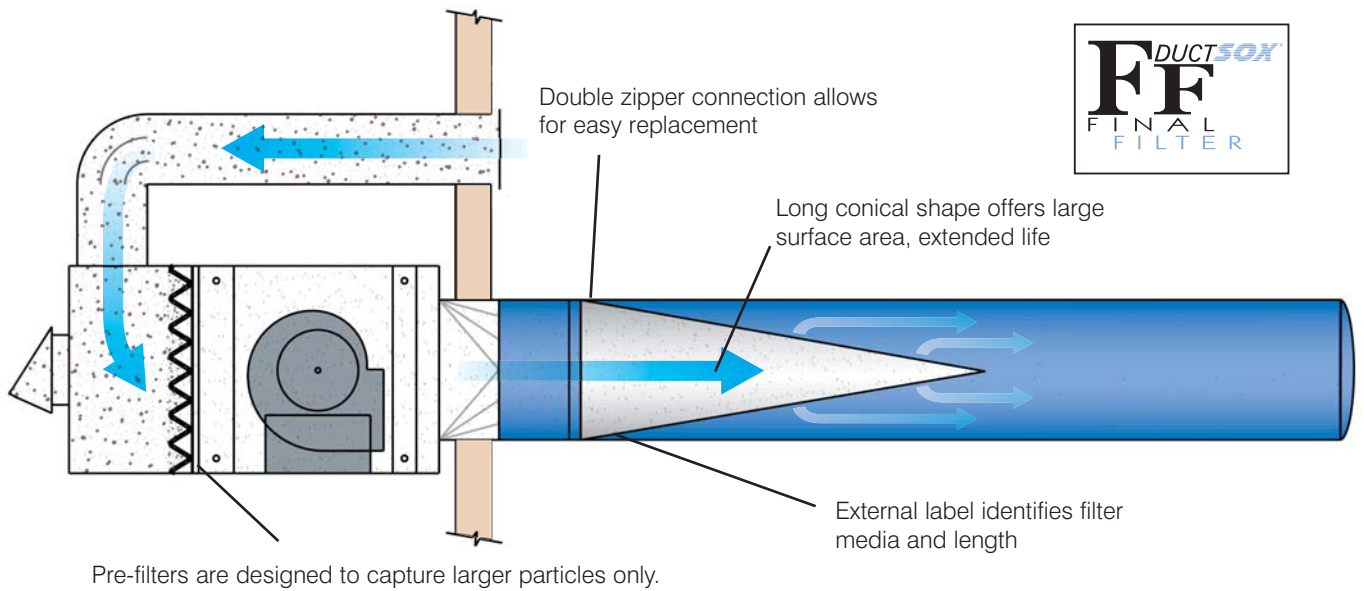

Why would you put a final filter in a DuctSox?

- ◀ Filter the air just before you breathe it
- ◀ Reduce dirt build-up in DuctSox system
- ◀ 100% filtration of air dispersed by DuctSox
- ◀ No additional filter bay required - inside the DuctSox
- ◀ Conical shape provides large loading area, extended life
- ◀ Simple zip in construction, easy replacement

LENGTH	MERV-8 (~50% EFF)	MERV-12 (~90% EFF)
4.5xØ	8M	12M
6.0xØ	8L	12L
9.0xØ	8X	12X

DuctSox Final Filters are available in two filter media, all diameters and in three different lengths: M, L or X. The shortest, or M length filter is 4.5x the diameter in length, the L and X are 6x and 9x respectively.

Pressure resistance ranges from 0.15" - 0.59" w.g. (MERV-8) and 0.44" - 1.97" w.g. (MERV-12) clean.

Filtration Efficiency*

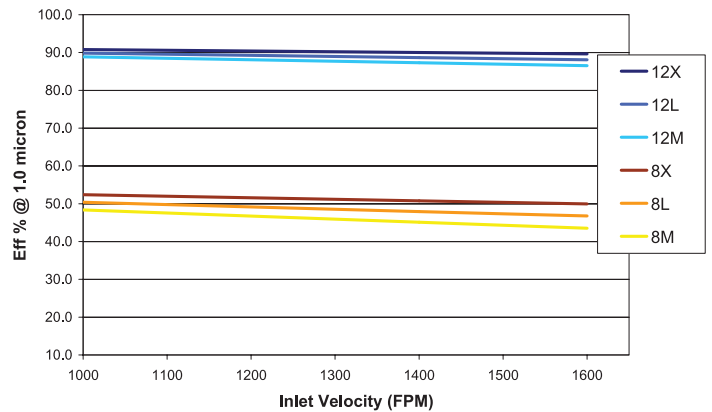

*Chart reflects performance for clean filter only

Pressure Drop* vs. Inet Velocity

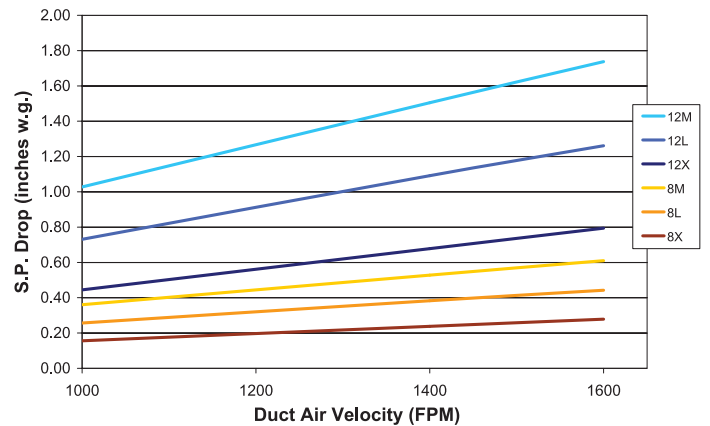

*Chart reflects performance for clean filter only



4343 Chavenelle Road, Dubuque, IA 52002-2654
Toll Free Phone: 866-382-8769 / Fax: 866-398-1646
Direct Phone: 563-589-2777 / Fax: 563-589-2754

Please Visit Our Website:
www.ductsox.com

DSC005G0507A-DS

Products may be covered by one or more of the following patents:
6899615, 6958011, 6953396, 6960130, 6565430, 6558250,
5769708, 6425754, 6625754, 6280320, 5961044, 5655963
A Subsidiary of Rite Hite Holding Corporation