

# Installation, Operation, and Maintenance

## Split System Air Handlers 5-20 Tons

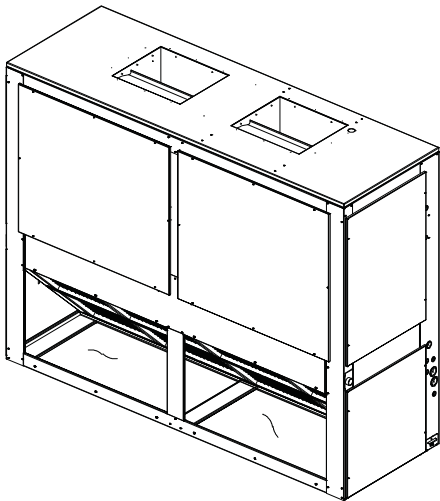

### Model (60 Hz)

TWE061D/E\*\*\*A  
TWE090D/E\*\*\*A  
TWE120D/E\*\*\*A  
TWE150E\*\*\*A  
TWE180E\*\*\*A  
TWE240E\*\*\*A

### Model (50 Hz)

TWE051D\*\*\*A  
TWE076D\*\*\*A  
TWE101D/E\*\*\*A  
TWE126E\*\*\*A  
TWE156E\*\*\*A  
TWE201E\*\*\*A

### SAFETY WARNING

Only qualified personnel should install and service the equipment. The installation, starting up, and servicing of heating, ventilating, and air-conditioning equipment can be hazardous and requires specific knowledge and training. Improperly installed, adjusted or altered equipment by an unqualified person could result in death or serious injury. When working on the equipment, observe all precautions in the literature and on the tags, stickers, and labels that are attached to the equipment.

# Warnings, Cautions and Notices

**Warnings, Cautions and Notices.** Note that warnings, cautions and notices appear at appropriate intervals throughout this manual. Warnings are provided to alert installing contractors to potential hazards that could result in personal injury or death. Cautions are designed to alert personnel to hazardous situations that could result in personal injury, while notices indicate a situation that could result in equipment or property-damage-only accidents.

Your personal safety and the proper operation of this machine depend upon the strict observance of these precautions.

**ATTENTION:** Warnings, Cautions and Notices appear at appropriate sections throughout this literature. Read these carefully.



**WARNING:** Indicates a potentially hazardous situation which, if not avoided, could result in death or serious injury.



**CAUTION:** Indicates a potentially hazardous situation which, if not avoided, could result in minor or moderate injury. It could also be used to alert against unsafe practices.

**NOTICE:** Indicates a situation that could result in equipment or property-damage only accidents.

## Important Environmental Concerns!

Scientific research has shown that certain man-made chemicals can affect the earth's naturally occurring stratospheric ozone layer when released to the atmosphere. In particular, several of the identified chemicals that may affect the ozone layer are refrigerants that contain Chlorine, Fluorine and Carbon (CFCs) and those containing Hydrogen, Chlorine, Fluorine and Carbon (HCFCs). Not all refrigerants containing these compounds have the same potential impact to the environment. Trane advocates the responsible handling of all refrigerants-including industry replacements for CFCs such as HCFCs and HFCs.

## Responsible Refrigerant Practices!

Trane believes that responsible refrigerant practices are important to the environment, our customers, and the air conditioning industry. All technicians who handle refrigerants must be certified. The Federal Clean Air Act (Section 608) sets forth the requirements for handling, reclaiming, recovering and recycling of certain refrigerants and the equipment that is used in these service procedures. In addition, some states or municipalities may have additional requirements that must also be adhered to for responsible management of refrigerants. Know the applicable laws and follow them.



### **WARNING**

#### **R-410A Refrigerant under Higher Pressure than R-22!**

The unit described in this manual uses R-410A refrigerant which operates at higher pressures than R-22 refrigerant. Use ONLY R-410A rated service equipment or components with this unit. For specific handling concerns with R-410A, please contact your local Trane representative. Failure to use R-410A rated service equipment or components could result in equipment or components exploding under R-410A high pressures which could result in death, serious injury, or equipment damage.

 **WARNING**

**Contains R-410A Refrigerant!**

System contains oil and refrigerant under high pressure. Recover refrigerant to relieve pressure before opening the system. See unit nameplate for refrigerant type. Do not use non-approved refrigerants, refrigerant substitutes, or refrigerant additives. Failure to follow proper procedures or the use of non-approved refrigerants, refrigerant substitutes, or refrigerant additives could result in death or serious injury or equipment damage.

**Important:** *DO NOT release refrigerant to the atmosphere! If adding or removing refrigerant is required, the service technician must comply with all federal, state, and local laws.*

**Important:** *One copy of this document ships inside the control panel of each unit and is customer property. It must be retained by the unit's maintenance personnel.*

 **WARNING**

**Personal Protective Equipment (PPE) Required!**

Installing/servicing this unit could result in exposure to electrical, mechanical and chemical hazards.

- Before installing/servicing this unit, technicians **MUST** put on all Personal Protective Equipment (PPE) recommended for the work being undertaken. **ALWAYS** refer to appropriate MSDS and OSHA guidelines for proper PPE.
- When working with or around hazardous chemicals, **ALWAYS** refer to appropriate MSDS and OSHA guidelines for information on allowable personal exposure levels, proper respiratory protection and handling recommendations.
- If there is a risk of arc or flash, technicians **MUST** put on all Personal Protective Equipment (PPE) in accordance with NFPA70E or other country-specific requirements for arc/flash protection **PRIOR** to servicing the unit.

**Failure to follow recommendations could result in death or serious injury.**

This booklet describes proper installation, operation, and maintenance procedures for air cooled systems. By carefully reviewing the information within this manual and following the instructions, the risk of improper operation and/or component damage will be minimized.

It is important that periodic maintenance be performed to help assure trouble free operation. Should equipment failure occur, contact a qualified service organization with qualified, experienced HVAC technicians to properly diagnose and repair this equipment.

**Important:** *All phases of this installation must comply with the NATIONAL, STATE & LOCAL CODES. In addition to local codes, the installation must conform with National Electric Code -ANSI/NFPA NO. 70 LATEST REVISION.*

Any individual installing, maintaining, or servicing this equipment must be properly trained, licensed and qualified.

# Table of Contents

Model Number Description .....	5
General Information .....	6
Installation Checklist .....	6
Unit Inspection .....	6
Initial Leak Test .....	6
Lifting Recommendations .....	6
Pre-Installation .....	8
Repositioning Drain Pan .....	8
Field Conversion to 460 Volt .....	9
Refrigerant Piping .....	11
Installations, Limitations and Recommendations .....	12
Dimensional Data .....	13
Electrical Data .....	22
Installation .....	30
Horizontal Suspension .....	30
Refrigerant Piping .....	31
Condensate Piping .....	32
Filters .....	32
Duct Connections .....	32
Air Flow Settings .....	32
Electrical Connections .....	33
Checkout Procedure .....	34
Installation Checklist .....	34
Electrical Wiring .....	34
Thermostat and Control Connections for Electromechanical Controls ..	35
Thermostat and Control Connections for ReliaTel™ Controls .....	36
Maintenance .....	38
Fan Belt Adjustment .....	38
Monthly .....	39
Annually (Cooling Season) .....	40
Coil Cleaning .....	40
Precautionary Measures .....	41
First Aid Measures .....	41
Maintenance Log .....	42
Warranty .....	43
Central Air Conditioner .....	43
Commercial Equipment Rated 20 Tons and Larger and Related Accessories (Parts Only) .....	43
Wiring Diagram Matrix .....	45

# Model Number Description

T W E	2 0 1	E	D	0 0	*	*
1 2 3	4 5 6	7	8	9 10	11	12

## Model Number Description

All products are identified by a multiple-character model number that precisely identifies a particular type of unit. An explanation of the alphanumeric identification code is provided. Its use will enable the owner/operator, installing contractors, and service engineers to define the operation, specific components, and other options for any specific unit.

**Note:** When ordering replacement parts or requesting service, be sure to refer to the specific model number, serial number, and DL number (if applicable) stamped on the unit nameplate.

### DIGITS 1 - 3: Product Type

TWE = Split System Heat Pump/Cooling Air Handler

### DIGITS 4 - 6: Nominal Gross Cooling Capacity (MBh)

061 = 5 Tons (60 Hz)	051 = 4.6 Tons (50 Hz)
090 = 7½ Tons (60 Hz)	076 = 6.25 Tons (50 Hz)
120 = 10 Tons (60 Hz)	101 = 8.33 Tons (50 Hz)
150 = 12½ Tons (60 Hz)	126 = 10.4 Tons (50 Hz)
180 = 15 Tons (60 Hz)	156 = 13 Tons (50 Hz)
240 = 20 Tons (60 Hz)	201 = 16.7 Tons (50 Hz)

### DIGIT 7: Major Development Sequence

D = Single Circuit  
E = Dual Circuit

### DIGIT 8: Electrical Characteristics

1 = 208-230/60/1	W = 575/60/3
3 = 208-230/60/3	D = 380-415/50/3
4 = 460/60/3	K = 380/60/3

### DIGITS 9 - 10: Factory Installed Options

00 = Packed Stock

### DIGITS 11: Minor Design Sequence

\* = Current Design Sequence<sup>1</sup>

### DIGITS 12: Service Digit

\* = Current Design Sequence<sup>1</sup>

<sup>1</sup> \* = sequential alpha character

# General Information

Installation procedures should be performed in the sequence that they appear in this manual. Do not destroy or remove the manual from the unit.

The manual should remain weather-protected with the unit until all installation procedures are complete.

**Note:** *It is not the intention of this manual to cover all possible variations in systems that may occur or to provide comprehensive information concerning every possible contingency that may be encountered during an installation. If additional information is required or if specific problems arise that are not fully discussed in this manual, contact your local sales office.*

This manual covers installation of the TWE air handlers. These air handler models incorporate a single slab coil assembly, improved application flexibility, servicing, maintenance accessibility and an improved accessory line. They are fully convertible, (vertical to horizontal discharge) without field removal of the coil assembly. They are shipped ready for horizontal installation.

All units have one drain pan that can be installed in any one of four positions. This allows for vertical or horizontal applications and right or left exit.

**Important:** *All dual circuit (digit 7 = E) have an intertwined coil.*

## Installation Checklist

An "Installation Checklist" is provided at the end of the installation section of this manual. Use the checklist to verify that all necessary installation procedures have been completed. Do not use the checklist as a substitute for reading the information contained in the manual. Read the entire manual before beginning installation procedures.

## Unit Inspection

Inspect material carefully for any shipping damage. If damaged, it must be reported to, and claims made against the transportation company. Compare the information that appears on the unit nameplate with ordering and submittal data to ensure the proper unit was shipped. Available power supply must be compatible with electrical characteristics specified on component nameplates. Replace damaged parts with authorized parts only.

## Initial Leak Test

All TWE units are shipped with a holding charge of nitrogen in each circuit. Remove the access panel shown in [Figure 13, p. 21](#). Locate the liquid line or suction line access valve for each circuit. Install gauges to determine if the circuits are still pressurized. If not, the charge has escaped. Repair as required to obtain a leak-free circuit.

## Lifting Recommendations

### **WARNING**

#### **Improper Unit Lift!**

Each of the cables (chains or slings) used to lift the unit must be capable of supporting the entire weight of the unit. Lifting cables (chains or slings) may not be of the same length. Adjust as necessary for even unit lift. Other lifting arrangements may cause equipment or property-only damage. Failure to properly lift unit could result in death or serious injury. Refer to [Table 1](#) and [Table 2](#) for unit weight.

### **NOTICE**

#### **Equipment Damage!**

Use spreader bars to prevent straps from damaging the unit. Install the bars between lifting straps, both underneath the unit and above the unit. This will prevent the straps from crushing the unit cabinet or damaging the unit finish.

Before preparing the unit for lifting, estimate the approximate center of gravity for lifting safety. Because of placement of internal components, the unit weight may be unevenly distributed. Approximate unit weights are given in [Table 1](#) and [Table 2, p. 7](#).

The crated unit can be moved using a forklift of suitable capacity. For lifting the unit into an elevated mounting position, run lifting straps or slings under the unit and attach securely to the lifting device.

**Table 1. TWE Unit and Corner Weights - lbs (60 Hz)**

Tons	Model No.	Shipping Max (lbs)	Net Max (lbs)	Corner Weights - Vertical				Corner Weights - Horizontal			
				1	2	3	4	A	B	C	D
5	TWE061D/E	263	232	55	71	51	55	54	67	50	61
7½	TWE090D/E	360	323	67	99	75	82	56	92	87	88
10	TWE120D/E	429	393	77	121	110	85	79	118	77	119
12½	TWE150E	730	676	168	192	181	135	196	164	145	171
15	TWE180E	729	675	167	192	181	135	196	163	145	171
20	TWE240E	891	818	258	168	161	231	256	181	146	235

**Table 2. TWE Unit and Corner Weights - kg (50 Hz)**

Tons	Model No.	Shipping Max (kg)	Net Max (kg)	Corner Weights - Vertical				Corner Weights - Horizontal			
				1	2	3	4	A	B	C	D
5	TWE051D/E	118	104	25	32	23	25	24	30	23	27
7½	TWE076D/E	162	145	30	45	34	37	25	41	39	40
10	TWE101D/E	193	177	35	54	50	38	36	53	35	54
12½	TWE126E	329	304	76	86	81	61	88	74	65	77
15	TWE156E	328	304	75	86	81	61	88	73	65	77
20	TWE201E	401	368	116	76	72	104	115	81	66	106

# Pre-Installation

The final position for the air handler must be dictated by required service access to it, weight distribution over structural supports, and by the locations of electrical, refrigerant and condensate drainage connections. After this is determined, the following preparations should be made.

## Repositioning Drain Pan

These air handlers come with one drain pan that can be installed in any one of four positions; this allows for vertical or horizontal application and right or left condensate line connection. The drain pan can also be easily removed for periodic cleaning.

**Note:** Important! All air handlers are shipped with the drain pan installed in the horizontal position and the connection on the left side (as shown in [Figure 1](#)). If an alternate position is required, the drain pan should be repositioned before setting the air handler.

**Figure 1. Drain Pan Location**

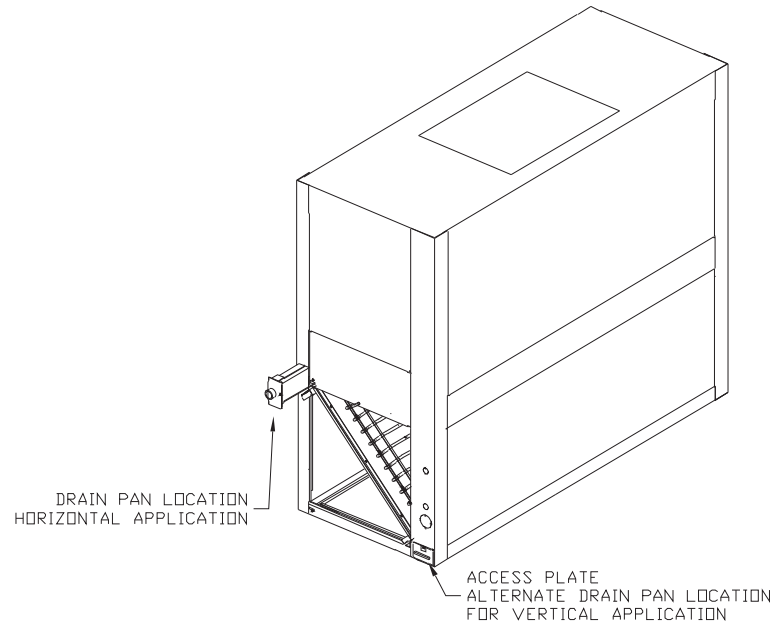

### Process for Drain Pan Relocation

1. Remove the access plate at the opposite end of the drain connection. This plate secures and lifts the back end of the drain pan for sloping. It must be removed before the drain pan can be removed. This is done as follows:
  - a. Remove the screw
  - b. Lift the access plate up
  - c. Pull the plate out. If the drain pan is to be moved to the vertical position also remove the other two access plates.
2. Remove the screw securing the drain pan.
  - a. Lift the pan up
  - b. Slide the pan out
3. Install the drain pan into the new position.
  - a. Slide the drain pan into the opening
  - b. Lift the drain pan up
  - c. Push it in all the way
  - d. Drop it down over the lip of the opening, secure with screw
4. Install the access plate on the opposite end of the drain pan.
  - a. Slide the edge of the access plate under the drain pan
  - b. Lift the access plate and drain pan up
  - c. Push the access plate in
  - d. Drop the access plate down over the lip of the opening, secure with screw. If the drain pan is being moved to the vertical position, install the other access plates over the horizontal position opening.

Figure 2. Drain Pan Relocation

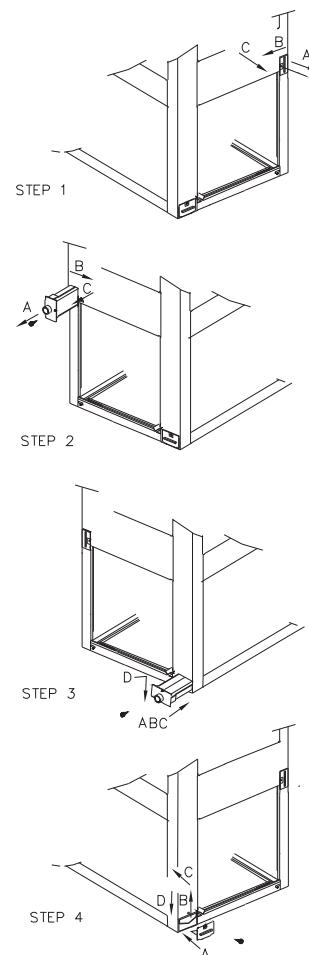

### NOTICE

#### System Component Damage!

These air handlers are shipped with a dry nitrogen holding charge in the coil. Depress or remove the access valve core to bleed off the nitrogen prior to brazing. Temporarily cap off tubes if the refrigerant line connections are to be made later.

### Field Conversion to 460 Volt

#### ⚠️ WARNING

#### Hazardous Voltage w/Capacitors!

Disconnect all electric power, including remote disconnects and discharge all motor start/run capacitors before servicing. Follow proper lockout/tagout procedures to ensure the power cannot be inadvertently energized. For variable frequency drives or other energy storing components provided by Trane or others, refer to the appropriate manufacturer's literature for allowable waiting periods for discharge of capacitors. Verify with an appropriate voltmeter that all capacitors have discharged. Failure to disconnect power and discharge capacitors before servicing could result in death or serious injury.

**⚠️ WARNING**  
**Grounding Required!**

Follow proper local and state electrical code on requirements for grounding. Failure to follow code could result in death or serious injury.

- Available power supply must agree with electrical data on component nameplate.
- Some air handlers are shipped wired for 208-230 volt applications and can be converted for 460 volt by rewiring the blower motor, see [Figure 3](#). (This includes models TWE090D3, TWE090E3, TWE120D3, TWE120E3, TWE150E3 and TWE180E3).

**Converting Motor to 460 Volt**

1. Ensure power is disconnected to unit by following the warning above.
2. Remove unit access panels closest to motor.
3. Open terminal cover on lead end of motor.
4. Pull voltage selector plug from low voltage selection (see [Figure 3](#)).
5. Shift the plug (or rotate 180°) to align plug for high voltage selection and re-insert plug.

**Important:** When re-inserting voltage selection plug, ensure it is fully seated.

6. Replace terminal cover on lead end of motor.
7. Replace unit access panels.

**Figure 3. Voltage Change Plug**

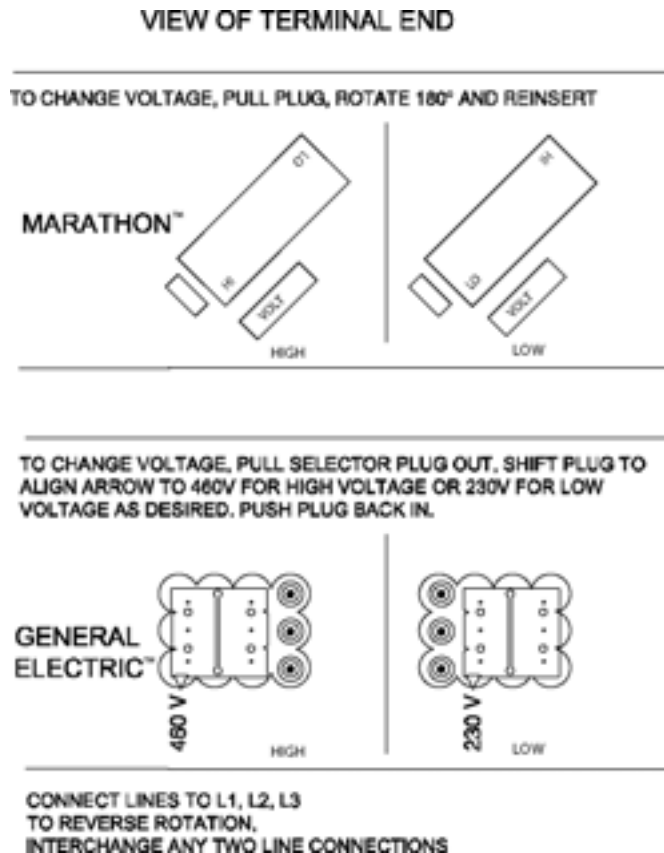

## Refrigerant Piping

### Evaporator Coil Orientation

**Important:** Applies only to TWE126/150 and 156/180 when positioned for vertical upflow. Unit is shipped in the horizontal position. If installing in the **vertical position**, the coil **must be** reoriented by rotating the coil 4 degrees (control box side) from the shipped position. See instructions and [Figure 4](#) below.

### Process for reorienting evaporator coil on TWE126, 150, 156 and 180 only.

1. Remove screws from top evaporator coil bracket (bracket that attaches coil to cabinet and runs the length of the unit).
2. Rotate evaporator coil approximately 4 degrees clockwise - looking from the control box end (see [Figure 4](#)). When the evaporator coil is rotated, the lower set of evaporator coil bracket holes will align with the support bracket (from which it was originally fastened).
3. Reinsert screws in evaporator coil bracket.

**Figure 4. Evaporator Coil Reorientation for TWE126, 150, 156, 180**

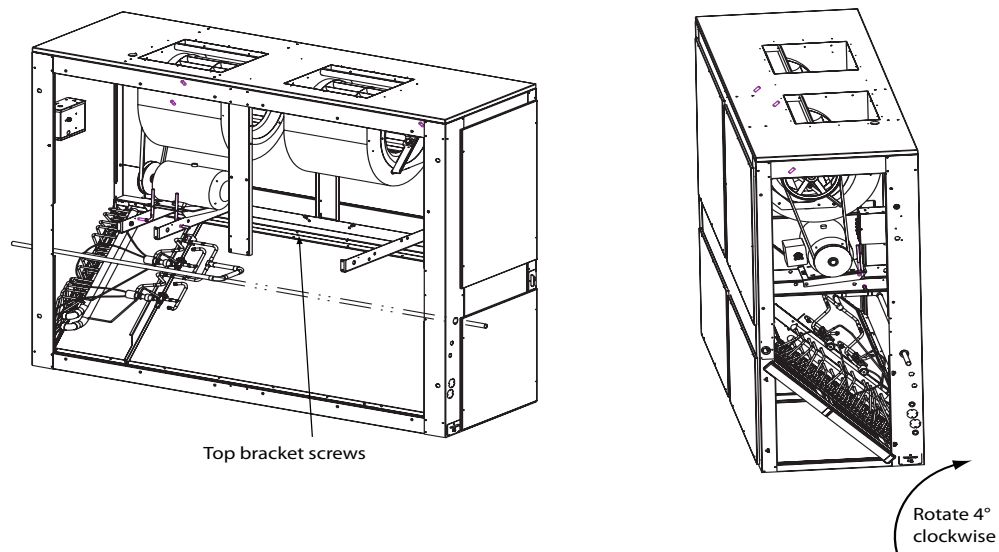

### Preparation

#### **NOTICE** Unit Damage!

**Do not apply heat to remove seal caps until the gauge port cores have been removed. If seal caps are intact, application of heat may generate excessive pressure in the unit and result in damage to the coil or expansion valve.**

The air handler is designed so that refrigerant piping can enter from either the right or left hand side. It is shipped with the intent that the refrigerant lines will enter from the left hand side. To convert to right hand entry, unbrazed the elbow on the suction line and rotate 180° and rebraze.

**Important:** Access to refrigerant lines is limited in all horizontal and some vertical applications. Therefore, refrigerant lines should be stubbed out and temporarily capped prior to setting the air handler. Protect adjacent surfaces from heat damage when brazing in and around the air handler.

### Installations, Limitations and Recommendations

#### **NOTICE**

#### **System Component Damage!**

**Properly insulate all refrigerant gas piping to prevent possible water damage due to condensation and to prevent capacity loss and possible compressor damage.**

The general location of the air handler is normally selected by the architect, contractor and/or buyer. For proper installation the following items must be considered.

- Available power supply must agree with electrical data on component nameplate.
- If external accessories are installed on the unit, additional clearances must be provided.
- All duct work should be properly insulated to prevent condensation and heat loss.
- Refrigerant gas piping must be insulated.

It is recommended that the outline drawings ([Figure 6, p. 14](#) - [Figure 13, p. 21](#)) be studied and dimensions properly noted and checked against the selected installation site. By noting in advance which features are to be used, proper clearance allowances can be made for installation and possible future service.

**Important:** *When installing these units “free standing” with discharge grills and isolators, a top support with isolator should be added to prevent tipping. Support and isolator can be attached to a wall or other appropriate structure.*

**Important:** *If adding external accessories to the unit, additional clearances must be considered for the overall space needed.*

For installation of accessories available for this air handler, follow the instructions packed with each accessory.

# Dimensional Data

Figure 5. TWE Quick Reference

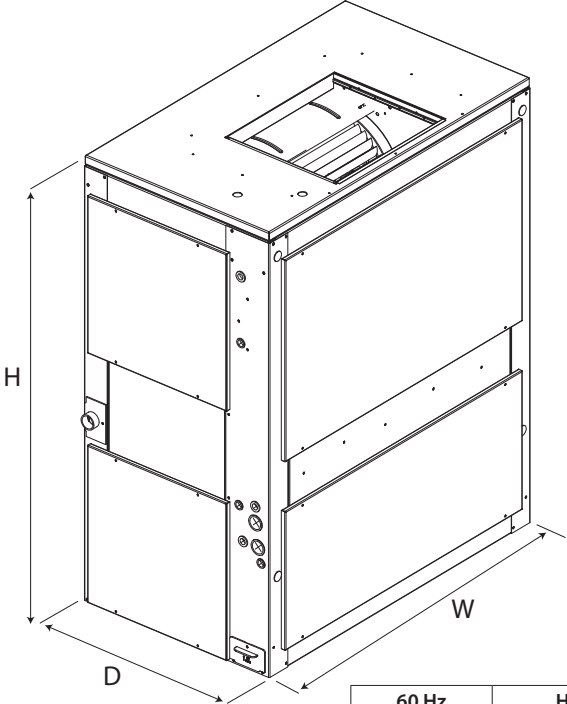

60 Hz	H	W	D
TWE061	48-1/8 (1222.4)	39-5/8 (1006.5)	23-5/8 (600)
TWE090	54-1/8 (1374.8)	49-1/8 (1247.8)	26-1/2 (673.1)
TWE120	54-1/8 (1374.8)	65-1/8 (1654.2)	26-1/2 (673.1)
TWE150, 180	69-1/8 (1756)	81-1/4 (2063.7)	30 (762)
TWE240	71-7/8 (1806.6)	94-1/4 (2394)	32-1/8 (816)

50 Hz	H	W	D
TWE051	48-1/8 (1222.4)	39-5/8 (1006.5)	23-5/8 (600)
TWE076	54-1/8 (1374.8)	49-1/8 (1247.8)	26-1/2 (673.1)
TWE101	54-1/8 (1374.8)	65-1/8 (1654.2)	26-1/2 (673.1)
TWE126, 156	69-1/8 (1756)	81-1/4 (2063.7)	30 (762)
TWE201	71-7/8 (1806.6)	94-1/4 (2394)	32-1/8 (816)

**Note:** Full dimensional data available on next pages.

# Dimensional Data

**Figure 6. TWE051, 061 Air Handler, Single Circuit — in (mm)**

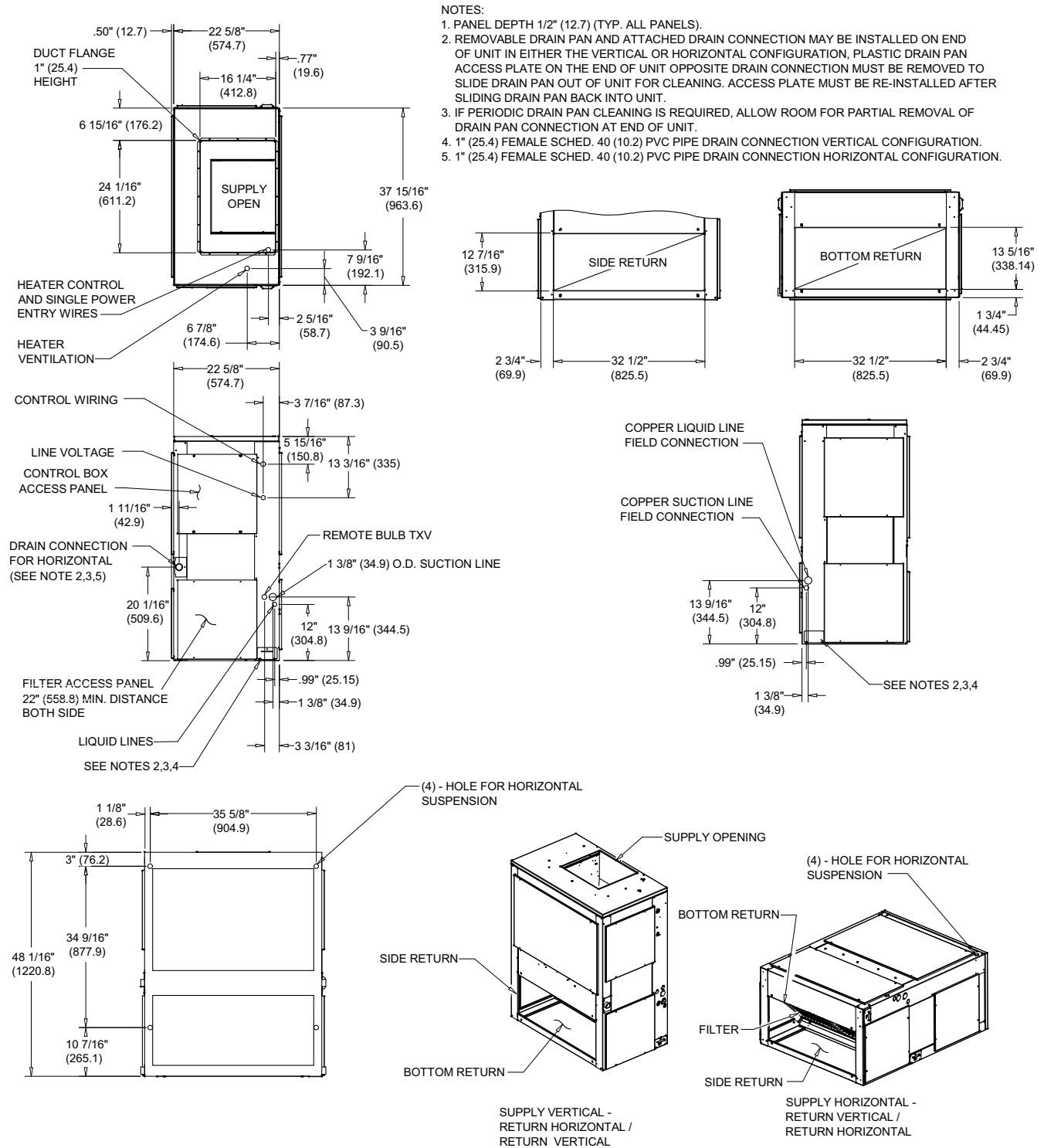

**4.6 - 6.25 TON AIR HANDLER (SINGLE CIRCUIT)**  
DIMENSIONAL DRAWING

Figure 7. TWE061 Air Handler, Dual Circuit – in (mm)

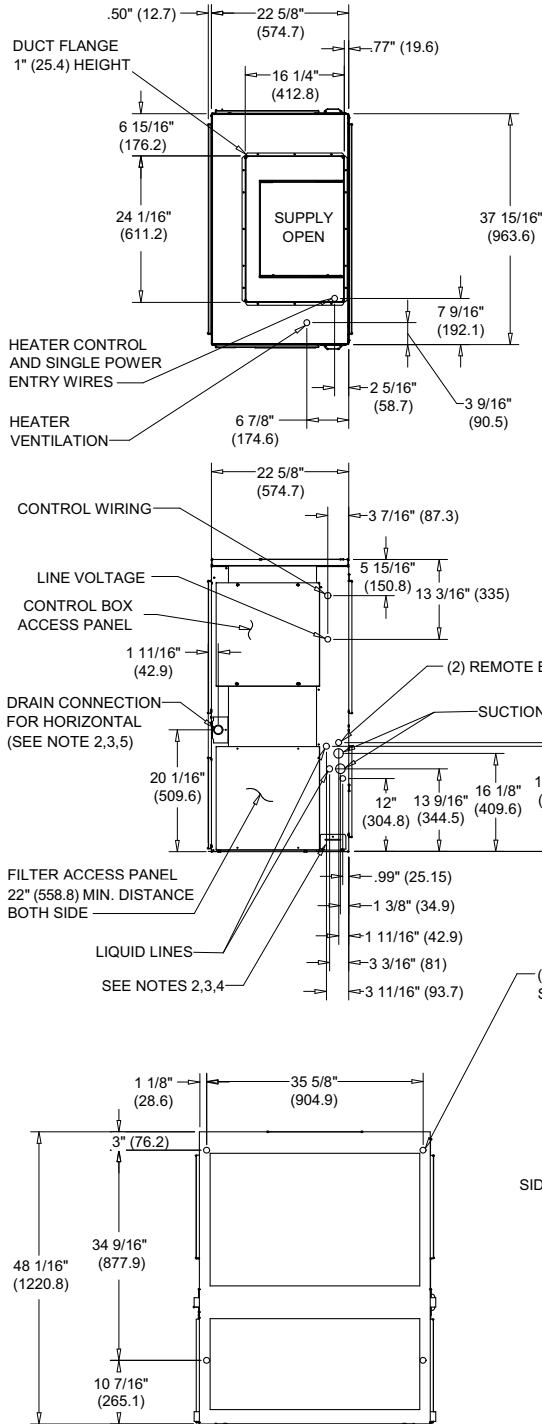

NOTES:

1. PANEL DEPTH 1/2" (12.7) (TYP. ALL PANELS).
2. REMOVABLE DRAIN PAN AND ATTACHED DRAIN CONNECTION MAY BE INSTALLED ON END OF UNIT IN EITHER THE VERTICAL OR HORIZONTAL CONFIGURATION. PLASTIC DRAIN PAN ACCESS PLATE ON THE END OF UNIT OPPOSITE DRAIN CONNECTION MUST BE REMOVED TO SLIDE DRAIN PAN OUT OF UNIT FOR CLEANING. ACCESS PLATE MUST BE RE-INSTALLED AFTER SLIDING DRAIN PAN BACK INTO UNIT.
3. IF PERIODIC DRAIN PAN CLEANING IS REQUIRED, ALLOW ROOM FOR PARTIAL REMOVAL OF DRAIN CONNECTION AT END OF UNIT.
4. 1" (25.4) FEMALE SCHED. 40 (10.2) PVC PIPE DRAIN CONNECTION VERTICAL CONFIGURATION.
5. 1" (25.4) FEMALE SCHED. 40 (10.2) PVC PIPE DRAIN CONNECTION HORIZONTAL CONFIGURATION.

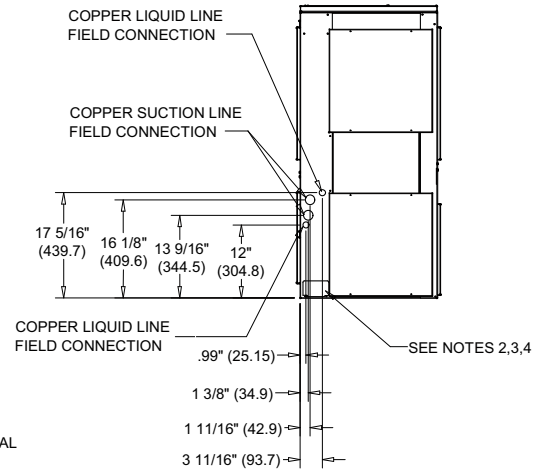
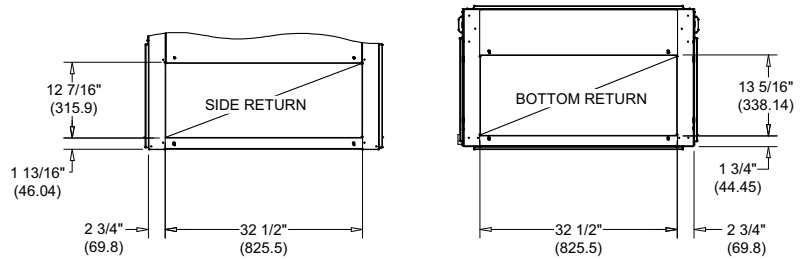

(4) - HOLE FOR HORIZONTAL SUSPENSION

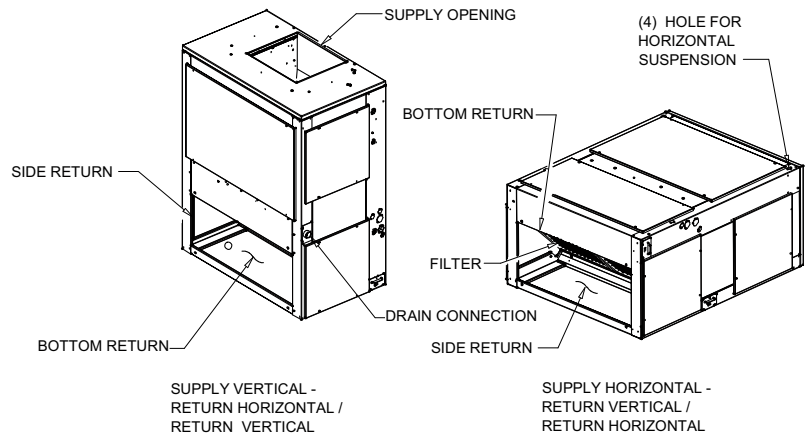

5 TON AIR HANDLER (DUAL CIRCUIT)  
DIMENSIONAL DRAWING

# Dimensional Data

**Figure 8. TWE076, 090 Air Handler, Single Circuit – in (mm)**

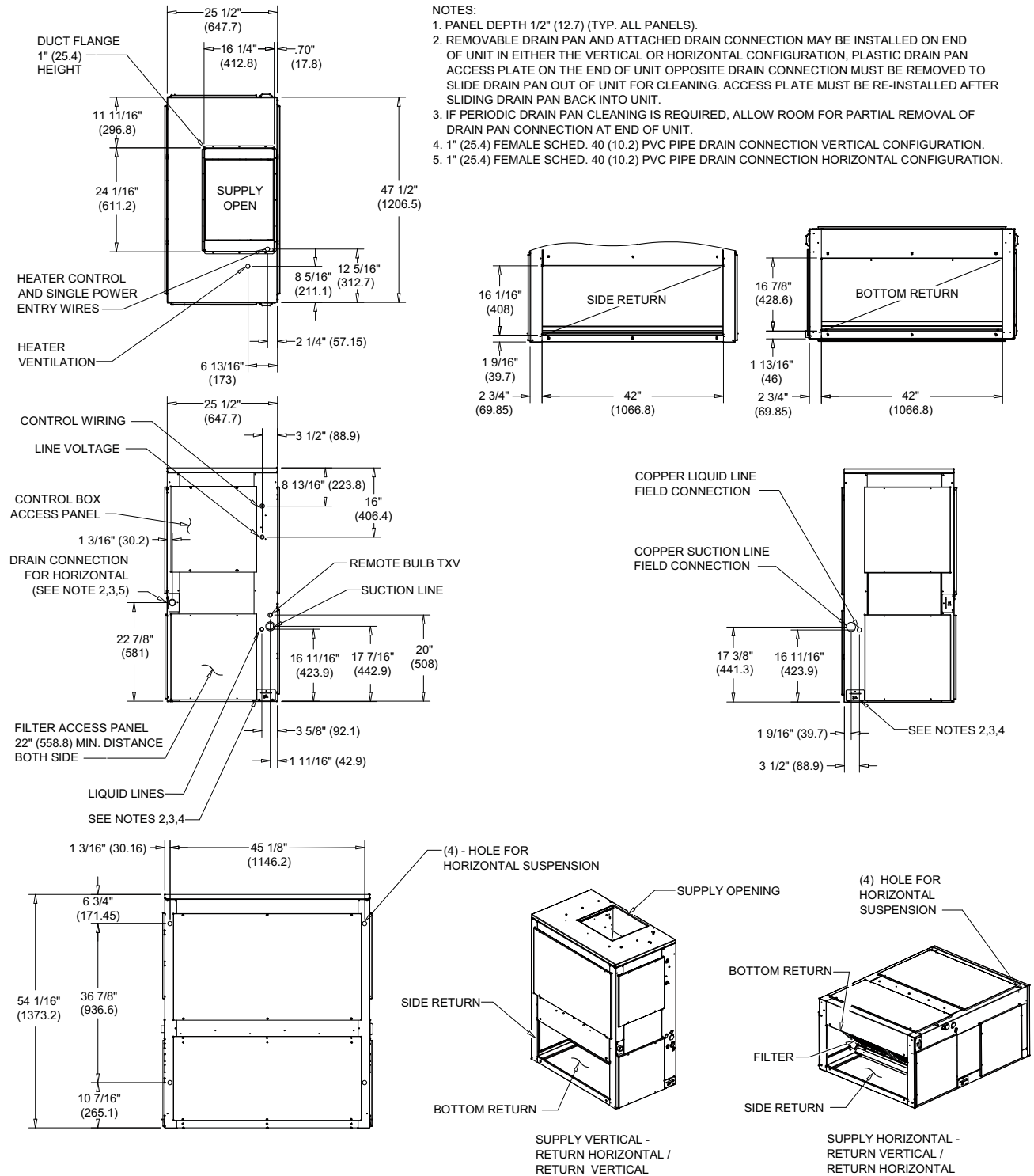

**6.25 - 7.5 TON AIR HANDLER (SINGLE CIRCUIT)**

DIMENSIONAL DRAWING

Figure 9. TWE090 Air Handler, Dual Circuit – in (mm)

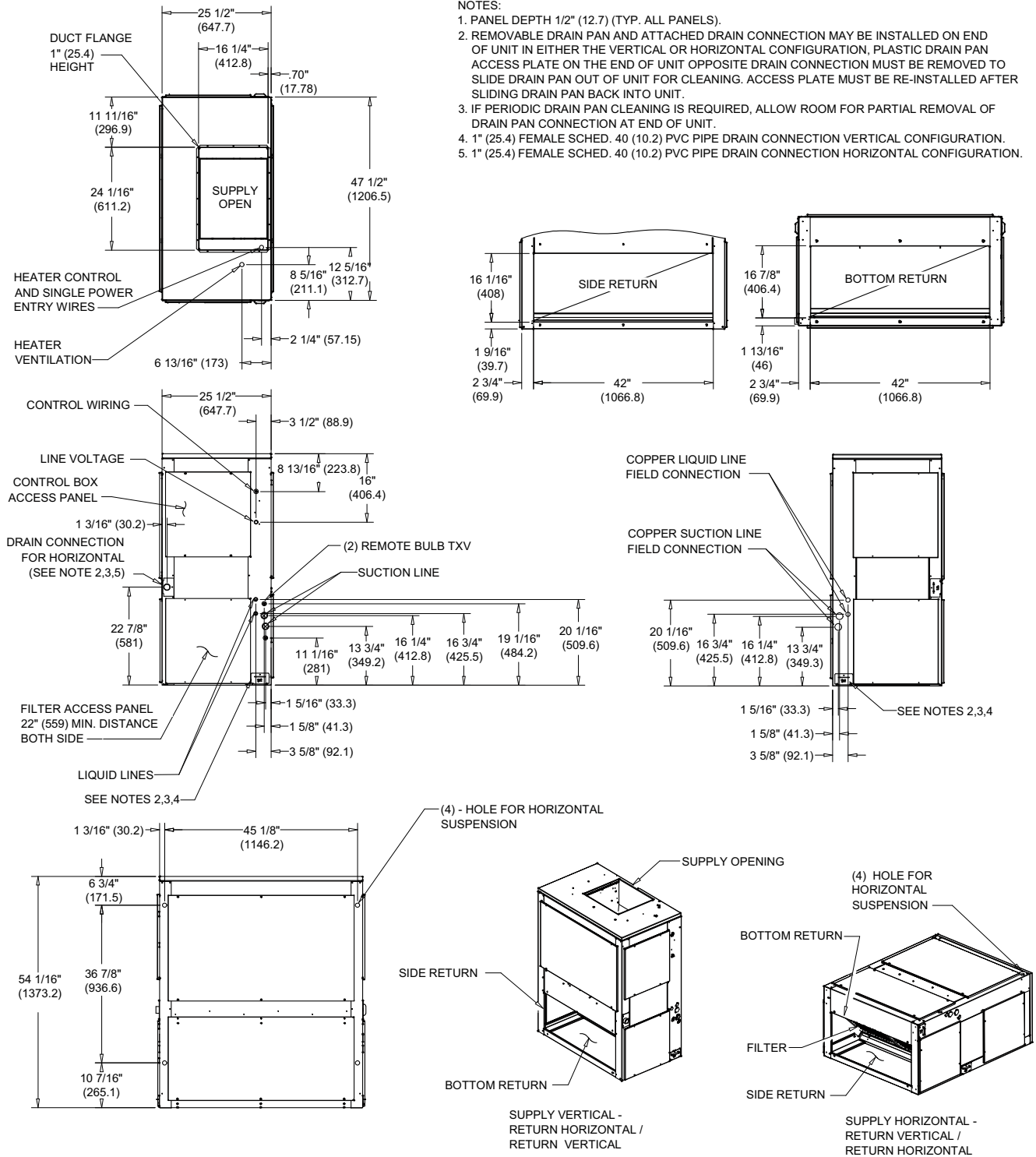

# Dimensional Data

**Figure 10. TWE101, 120 Air Handler, Single Circuit – in (mm)**

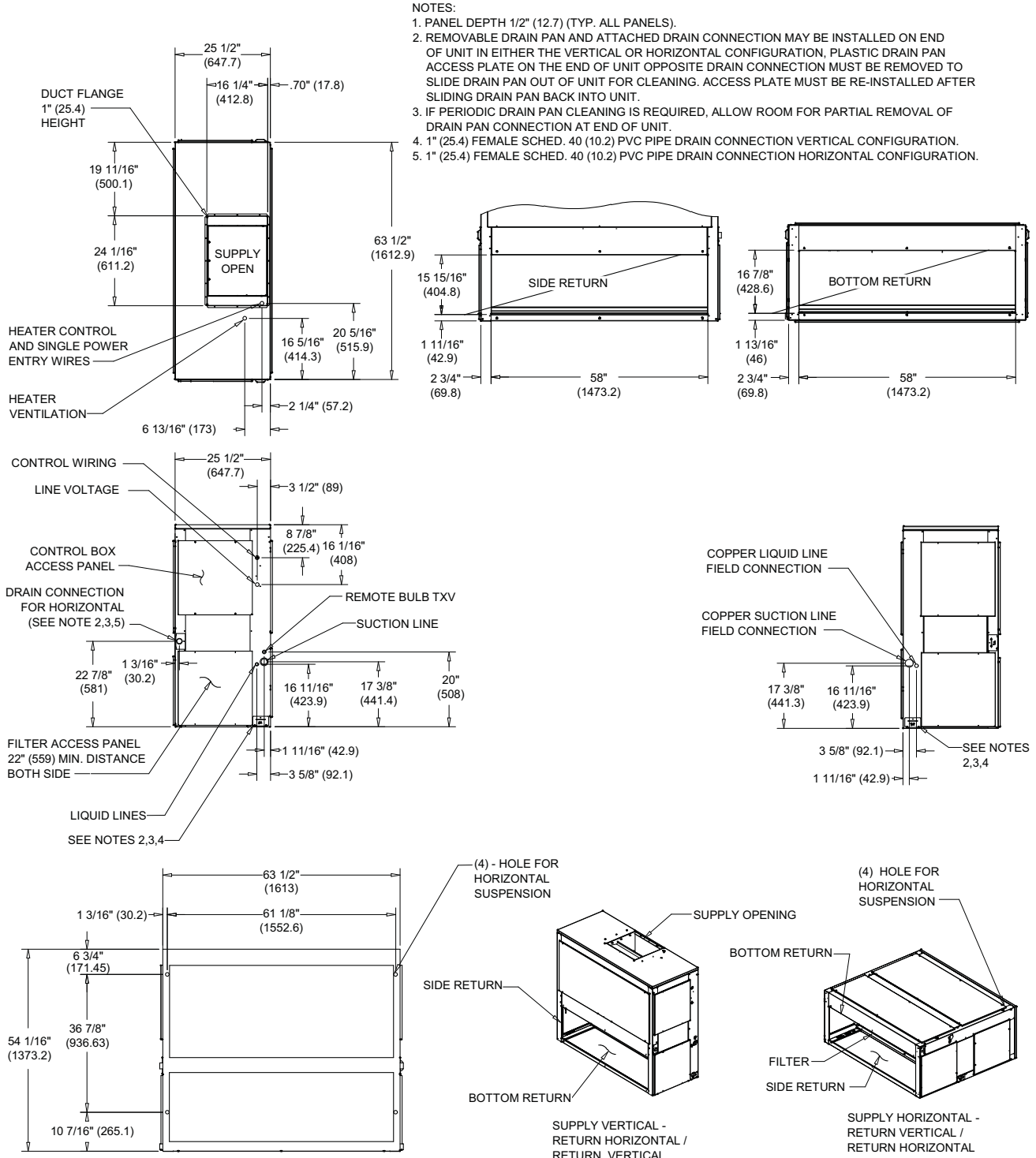

**10 - 10.4 TON AIR HANDLER (SINGLE CIRCUIT)**  
DIMENSIONAL DRAWING

Figure 11. TWE101, 120 Air Handler, Dual Circuit — in (mm)

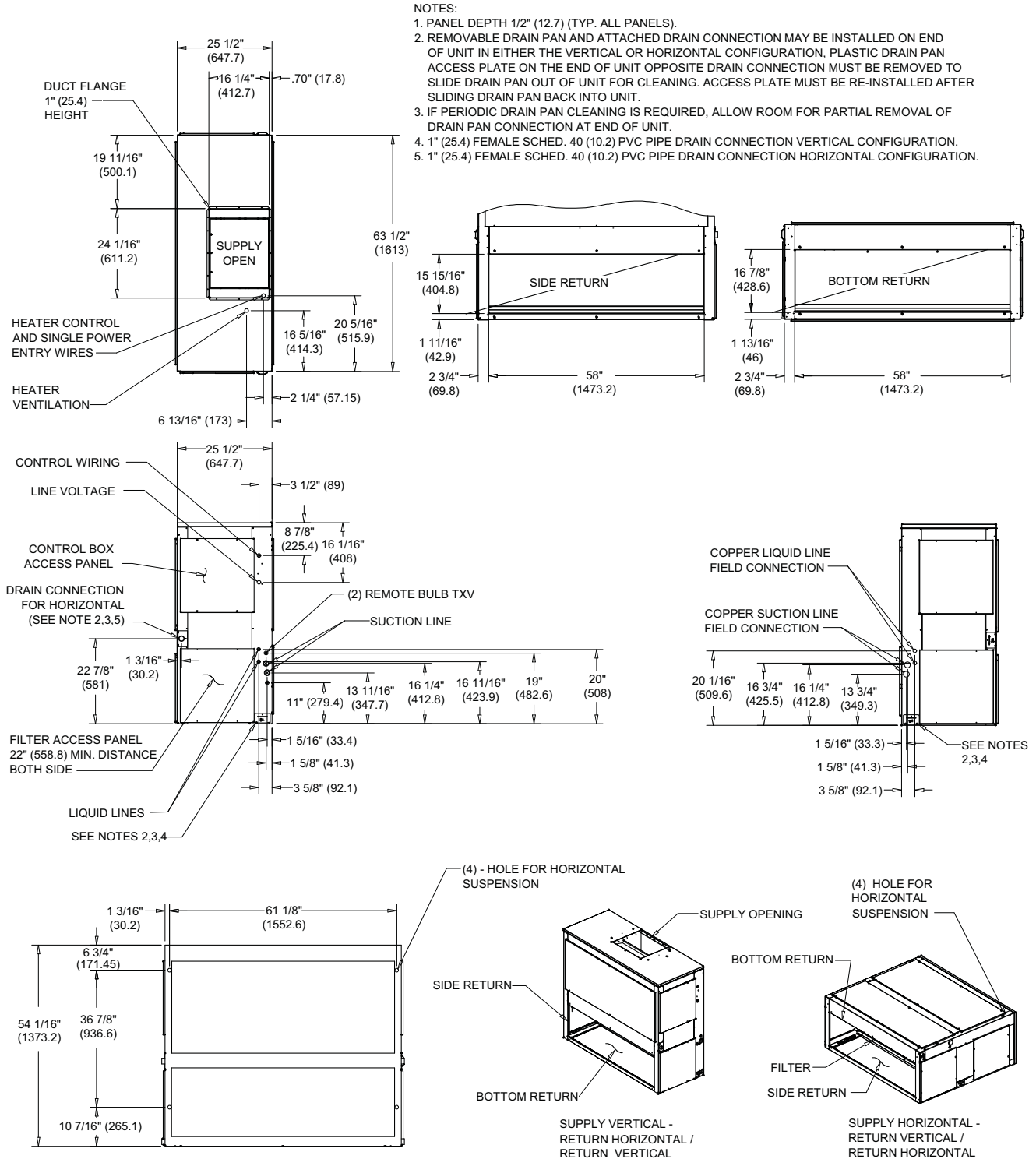

# Dimensional Data

**Figure 12. TWE126, 150, 156, 180 Air Handler, Dual Circuit – in (mm)**

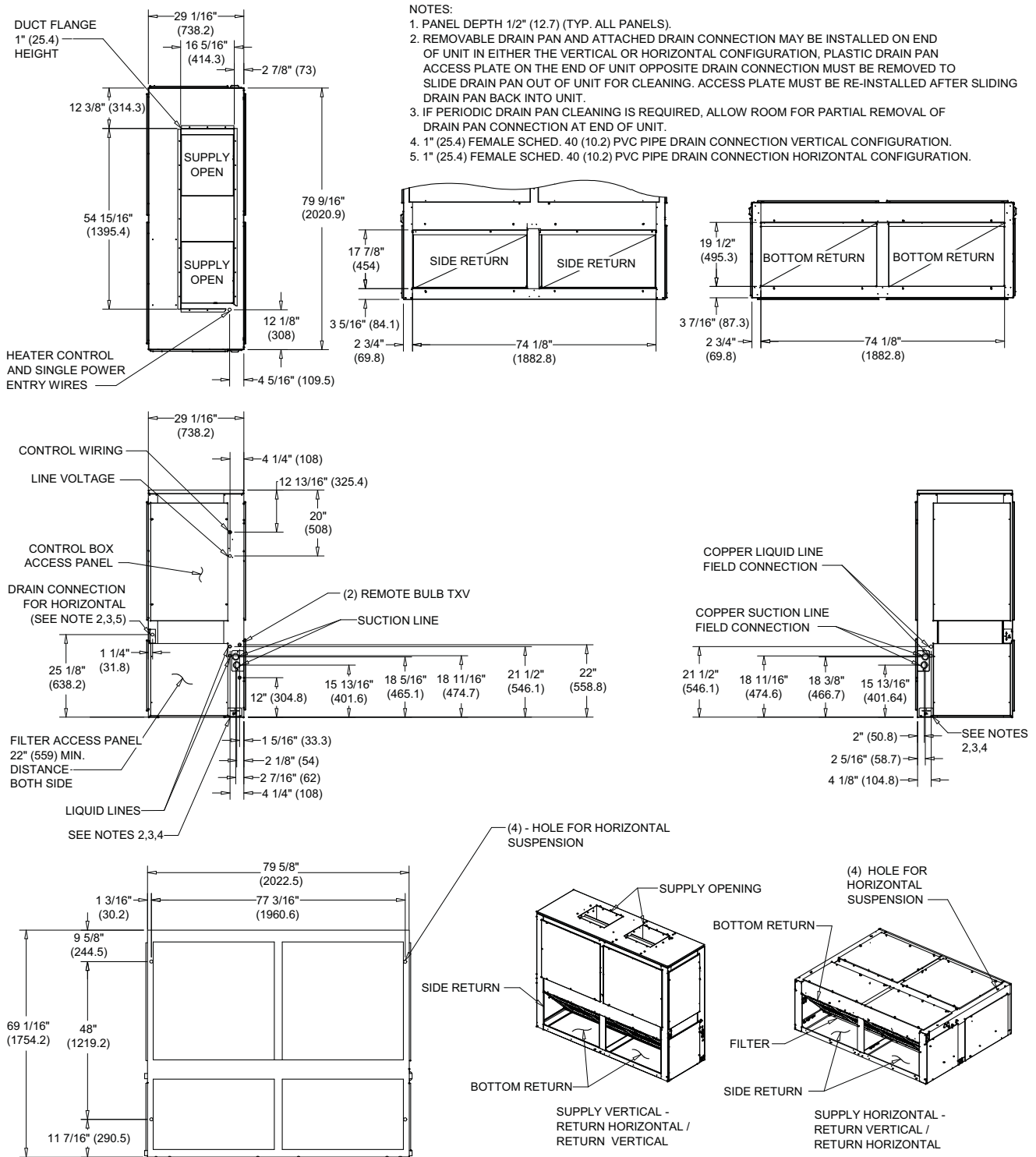

**10.4 - 15 TON AIR HANDLER (DUAL CIRCUIT)**  
DIMENSIONAL DRAWING

Figure 13. TWE201, 240 Air Handler, Dual Circuit — in (mm)

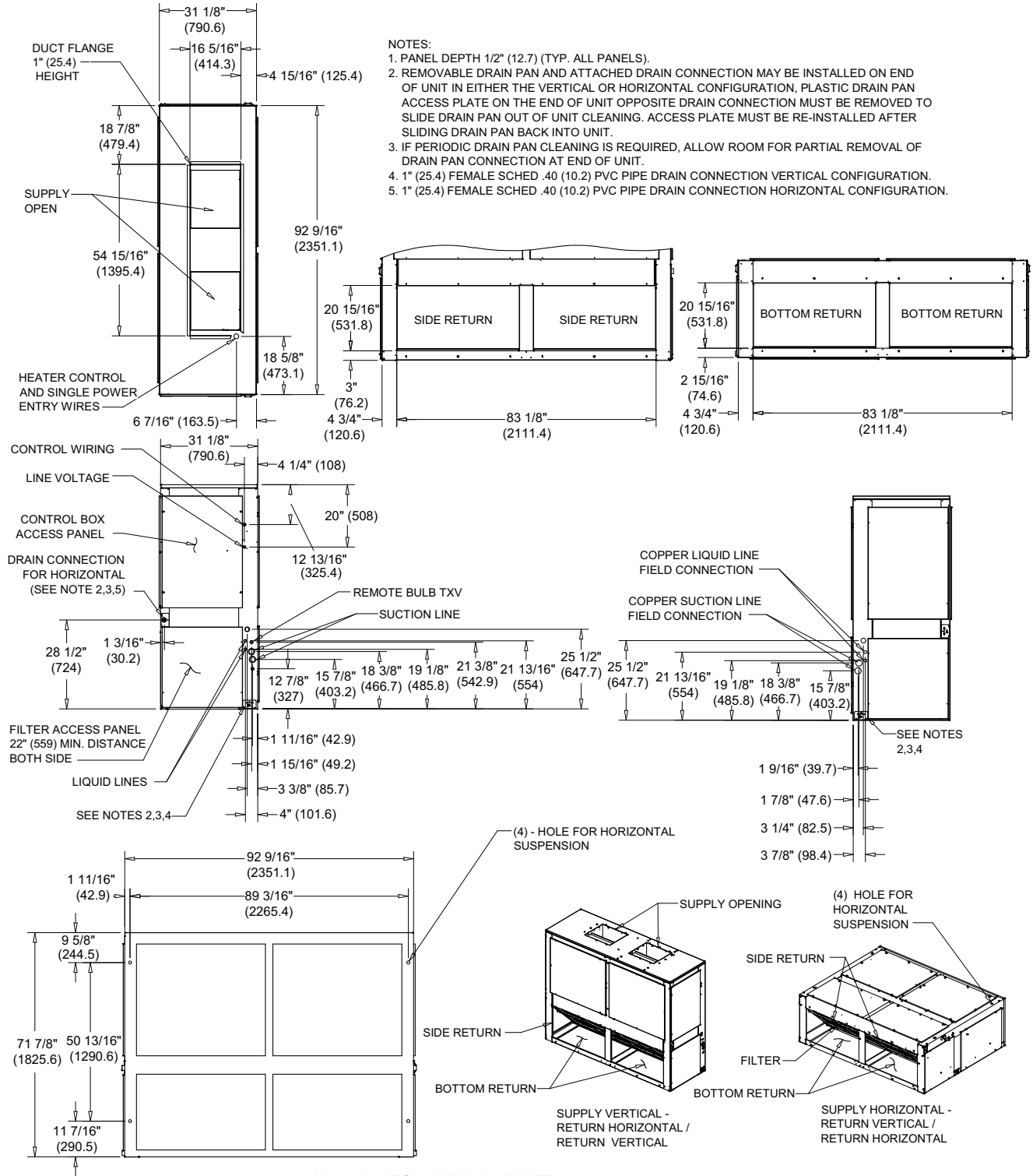

16.7 - 20 TON AIR HANDLER (DUAL CIRCUIT)  
DIMENSIONAL DRAWING

# Electrical Data

**Table 3. Electrical Characteristics — Standard and Low Static Motors — 60 Hz Air Handler<sup>(a)</sup>**

Tons	Unit Model Number	Standard Evaporator Fan Motor								Low Static Evaporator Fan Motor							
		No.	Volts	Phase	Hp	Amps		MCA	MFS	No.	Volts	Phase	Hp	Amps		MCA	MFS
						FLA	LRA							FLA	LRA		
5	TWE061D1, E1	1	208	1	0.75	6.0	41.0	7.5	15	N/A	N/A	N/A	N/A	N/A	N/A	N/A	N/A
	TWE061D1, E1	1	230	1	0.75	5.9	45.0	7.4	15	N/A	N/A	N/A	N/A	N/A	N/A	N/A	N/A
	TWE061D3, E3	1	208	3	0.75	2.5	16.4	3.1	15	N/A	N/A	N/A	N/A	N/A	N/A	N/A	N/A
	TWE061D3, E3	1	230	3	0.75	2.4	16.4	3.0	15	N/A	N/A	N/A	N/A	N/A	N/A	N/A	N/A
	TWE061D4, E4	1	460	3	0.75	1.2	8.2	1.5	15	N/A	N/A	N/A	N/A	N/A	N/A	N/A	N/A
	TWE061DW	1	575	3	0.75	1.3	6.1	1.6	15	N/A	N/A	N/A	N/A	N/A	N/A	N/A	N/A
7½	TWE090D1, E1	1	208	1	1.50	6.8	31.5	8.5	20	N/A	N/A	N/A	N/A	N/A	N/A	N/A	N/A
	TWE090D1, E1	1	230	1	1.50	6.2	31.5	7.8	15	N/A	N/A	N/A	N/A	N/A	N/A	N/A	N/A
	TWE090D3, E3	1	208	3	1.50	5.3	34.3	6.6	15	N/A	N/A	N/A	N/A	N/A	N/A	N/A	N/A
	TWE090D3, E3	1	230	3	1.50	5.0	34.3	6.3	15	N/A	N/A	N/A	N/A	N/A	N/A	N/A	N/A
	TWE090D3, E3 <sup>(b)</sup>	1	460	3	1.50	2.5	17.0	3.1	15	N/A	N/A	N/A	N/A	N/A	N/A	N/A	N/A
	TWE090DW	1	575	3	1.50	1.8	13.6	2.3	15	N/A	N/A	N/A	N/A	N/A	N/A	N/A	N/A
10	TWE120D1, E1	1	208	1	2.00	8.5	57.4	10.6	20	N/A	N/A	N/A	N/A	N/A	N/A	N/A	N/A
	TWE120D1, E1	1	230	1	2.00	7.7	57.4	9.6	20	N/A	N/A	N/A	N/A	N/A	N/A	N/A	N/A
	TWE120D3, E3	1	208	3	2.00	6.2	33.9	7.8	15	N/A	N/A	N/A	N/A	N/A	N/A	N/A	N/A
	TWE120D3, E3	1	230	3	2.00	5.8	33.9	7.3	15	N/A	N/A	N/A	N/A	N/A	N/A	N/A	N/A
	TWE120D3, E3 <sup>(b)</sup>	1	460	3	2.00	2.9	33.9	3.6	15	N/A	N/A	N/A	N/A	N/A	N/A	N/A	N/A
	TWE120DW, EW	1	575	3	2.00	2.3	14.4	2.9	15	N/A	N/A	N/A	N/A	N/A	N/A	N/A	N/A
12½	TWE150E3	1	208	3	2.00	5.95	23.0	7.4	15	N/A	N/A	N/A	N/A	N/A	N/A	N/A	N/A
	TWE150E3	1	230	3	2.00	5.5	23.0	6.9	15	N/A	N/A	N/A	N/A	N/A	N/A	N/A	N/A
	TWE150E3 <sup>(b)</sup>	1	460	3	2.00	2.75	23.0	3.4	15	N/A	N/A	N/A	N/A	N/A	N/A	N/A	N/A
	TWE150EW	1	575	3	2.00	2.2	18.0	2.8	15	N/A	N/A	N/A	N/A	N/A	N/A	N/A	N/A
15	TWE180E3	1	208	3	3.00	9.4	74.9	11.8	25	N/A	N/A	N/A	N/A	N/A	N/A	N/A	N/A
	TWE180E3	1	230	3	3.00	9.2	74.9	11.5	25	N/A	N/A	N/A	N/A	N/A	N/A	N/A	N/A
	TWE180E3 <sup>(b)</sup>	1	460	3	3.00	4.6	39.3	5.8	15	N/A	N/A	N/A	N/A	N/A	N/A	N/A	N/A
	TWE180EW	1	575	3	3.00	3.4	24.6	4.3	15	N/A	N/A	N/A	N/A	N/A	N/A	N/A	N/A
20	TWE240E3	1	208	3	5.00	14.0	90.8	17.5	35	1	208	3	3.00	9.4	74.9	11.8	25
	TWE240E3	1	230	3	5.00	13.6	103.0	17.0	35	1	230	3	3.00	9.2	74.9	11.5	25
	TWE240E4	1	460	3	5.00	6.6	44.8	8.3	20	1	460	3	3.00	4.6	39.3	5.8	15
	TWE240EW	1	575	3	5.00	5.3	36.2	6.6	15	1	575	3	3.00	3.4	24.6	4.3	15

Continued on next page

(a) For additional information contact product support.

(b) Field wired for 460V.

**Table 4. Electrical Characteristics — High and Ultra-High Static Motors — 60 Hz Air Handler<sup>(a)</sup>**

Tons	Unit Model Number	High Static Evaporator Fan Motor								Ultra-High Static Evaporator Fan Motor							
		No.	Volts	Phase	Hp	Amps		MCA	MFS	No.	Volts	Phase	Hp	Amps		MCA	MFS
						FLA	LRA							FLA	LRA		
5	TWE061D1, E1	1	208	1	1.50	6.8	31.5	8.5	20	N/A	N/A	N/A	N/A	N/A	N/A	N/A	N/A
	TWE061D1, E1	1	230	1	1.50	6.2	31.5	7.8	15	N/A	N/A	N/A	N/A	N/A	N/A	N/A	N/A
	TWE061D3, E3	1	208	3	1.50	5.3	34.3	6.6	15	N/A	N/A	N/A	N/A	N/A	N/A	N/A	N/A
	TWE061D3, E3	1	230	3	1.50	5.0	34.3	6.3	15	N/A	N/A	N/A	N/A	N/A	N/A	N/A	N/A
	TWE061D4, E4	1	460	3	1.50	2.5	17.0	3.1	15	N/A	N/A	N/A	N/A	N/A	N/A	N/A	N/A
	TWE061DW	1	575	3	1.50	1.8	13.6	2.3	15	N/A	N/A	N/A	N/A	N/A	N/A	N/A	N/A
7½	TWE090D1, E1	1	208	1	2.00	8.5	57.4	10.6	20	N/A	N/A	N/A	N/A	N/A	N/A	N/A	N/A
	TWE090D1, E1	1	230	1	2.00	7.7	57.4	9.6	20	N/A	N/A	N/A	N/A	N/A	N/A	N/A	N/A
	TWE090D3, E3	1	208	3	2.00	6.2	33.9	7.8	15	1	208	3	3.00	9.4	74.9	11.8	25
	TWE090D3, E3	1	230	3	2.00	5.8	33.9	7.3	15	1	230	3	3.00	9.2	74.9	11.5	25
	TWE090D3, E3 <sup>(b)</sup>	1	460	3	2.00	2.9	33.9	3.6	15	1	460	3	3.00	4.6	39.3	5.8	15
	TWE090DW	1	575	3	2.00	2.3	14.4	2.9	15	1	575	3	3.00	3.4	24.6	4.3	15
10	TWE120D1, E1	N/A	N/A	N/A	N/A	N/A	N/A	N/A	N/A	N/A	N/A	N/A	N/A	N/A	N/A	N/A	N/A
	TWE120D1, E1	N/A	N/A	N/A	N/A	N/A	N/A	N/A	N/A	N/A	N/A	N/A	N/A	N/A	N/A	N/A	N/A
	TWE120D3, E3	1	208	3	3.00	9.4	74.9	11.8	25	N/A	N/A	N/A	N/A	N/A	N/A	N/A	N/A
	TWE120D3, E3	1	230	3	3.00	9.2	74.9	11.5	25	N/A	N/A	N/A	N/A	N/A	N/A	N/A	N/A
	TWE120D3, E3 <sup>(b)</sup>	1	460	3	3.00	4.6	39.3	5.8	15	N/A	N/A	N/A	N/A	N/A	N/A	N/A	N/A
	TWE120DW, EW	1	575	3	3.00	3.4	24.6	4.3	15	N/A	N/A	N/A	N/A	N/A	N/A	N/A	N/A
12½	TWE150E3	1	208	3	3.00	9.4	74.9	11.8	25	1	208	3	5.00	14.0	98.0	17.5	35
	TWE150E3	1	230	3	3.00	9.2	74.9	11.5	25	1	230	3	5.00	13.6	103.0	17	35
	TWE150E3 <sup>(b)</sup>	1	460	3	3.00	4.6	39.3	5.8	15	1	460	3	5.00	6.6	44.8	8.3	20
	TWE150EW	1	575	3	3.00	3.4	24.6	4.3	15	1	575	3	5.00	5.2	36.2	6.5	15
15	TWE180E3	1	208	3	5.00	14.0	98.0	17.5	35	N/A	N/A	N/A	N/A	N/A	N/A	N/A	N/A
	TWE180E3	1	230	3	5.00	13.6	103.0	17	35	N/A	N/A	N/A	N/A	N/A	N/A	N/A	N/A
	TWE180E3 <sup>(b)</sup>	1	460	3	5.00	6.6	44.8	8.3	20	N/A	N/A	N/A	N/A	N/A	N/A	N/A	N/A
	TWE180EW	1	575	3	5.00	5.2	36.2	6.5	15	N/A	N/A	N/A	N/A	N/A	N/A	N/A	N/A
20	TWE240E3	N/A	N/A	N/A	N/A	N/A	N/A	N/A	N/A	1	208	3	7.50	20	114.0	25.0	45
	TWE240E3	N/A	N/A	N/A	N/A	N/A	N/A	N/A	N/A	1	230	3	7.50	17.6	126.0	22.0	40
	TWE240E4	N/A	N/A	N/A	N/A	N/A	N/A	N/A	N/A	1	460	3	7.50	9.0	61.4	11.3	25
	TWE240EW	N/A	N/A	N/A	N/A	N/A	N/A	N/A	N/A	1	575	3	7.50	7.2	49.8	9.0	20

(a) For additional information contact product support.

(b) Field wired for 460V.

## Electrical Data

**Table 5. Unit Wiring — Air Handler — 60Hz**

<b>Tons</b>	<b>Unit Model Number</b>	<b>Unit Operating Voltage Range</b>	<b>Minimum Circuit Ampacity</b>	<b>Maximum Fuse or HACR Circuit Breaker Size<sup>(a)</sup></b>
5	TWE06D1, E1	187-253	7.5	15
	TWE061D3, E3	187-253	3.1	15
	TWE061D4, E4	414-506	1.5	15
	TWE061DK	342-418	1.6	15
	TWE061DW	518-632	1.6	15
7½	TWE090D1, E1	187-253	8.5	20
	TWE090D3, E3 <sup>(b)</sup>	187-253	6.6	15
	TWE090D3, E3 <sup>(c)</sup>	414-506	3.1	15
	TWE090DK	342-418	3.8	15
	TWE090DW	518-632	2.3	15
10	TWE120D1, E1	187-253	10.6	20
	TWE120D3, E3 <sup>(b)</sup>	187-253	7.8	15
	TWE120D3, E3 <sup>(c)</sup>	414-506	3.6	15
	TWE120DK	342-418	4.1	15
	TWE120DW, EW	518-632	2.9	15
12½	TWE150E3	187-253	7.4	15
	TWE150E3 <sup>(c)</sup>	414-506	3.4	15
	TWE150EK	342-418	4.1	15
	TWE150EW	518-632	2.8	15
15	TWE180E3	187-253	11.8	25
	TWE180E3 <sup>(c)</sup>	414-506	5.8	15
	TWE180EK	342-418	8.2	15
	TWE180EW	518-632	4.3	15
20	TWE240E3	187-253	17.5	35
	TWE240E4	414-506	8.3	20
	TWE240EK	342-418	10.4	15
	TWE240EW	518-632	6.6	15

(a) HACR type circuit breaker per NEC.

(b) When wired for 208-230 volt.

(c) When wired for 460 volt.

**Table 6. Unit Wiring with Electric Heat (Single Point Connection) – 5, 7½ and 10 Ton Air Handlers – 60 Hz**

Tons	Used With	Heater Model No.	Maximum Fuse Heater KW Rating <sup>(a)</sup>	Unit Power Supply	Control Stages	Minimum Circuit Ampacity <sup>(b)</sup>	Maximum Fuse or HACR Circuit Breaker Size <sup>(b)(c)</sup>
5	TWE061D1 TWE061E1	BAYHTRL106A	4.33/5.76	208-230/1/60	1	33.5/37.4	35/40
		BAYHTRL112A	8.65/11.52		1	59.5/67.4	60/70
		BAYHTRL117A	12.98/17.28		1	85.5/97.4	90/100
		BAYHTRL123A	17.31/23.04		2	111.5/127.4 <sup>(d)</sup>	125/150
7½	TWE090D1 TWE090E1	BAYHTRL106A	4.33/5.76	208-230/1/60	1	34.5/37.8	40/40
		BAYHTRL112A	8.65/11.52		1	60.5/67.8 <sup>(d)</sup>	70/70
		BAYHTRL117A	12.98/17.28		1	86.5/97.8	90/100
		BAYHTRL123A	17.31/23.04		2	112.5/127.8 <sup>(d)</sup>	125/150
		BAYHTRL129A	21.63/28.80		2	138.6/157.8 <sup>(d)</sup>	150/175
10	TWE120D1 TWE120E1	BAYHTRL106A	4.33/5.76	208-230/1/60	1	36.6/39.6	40/45
		BAYHTRL112A	8.65/11.52		1	62.6/69.6 <sup>(d)</sup>	70/70
		BAYHTRL117A	12.98/17.28		1	88.6/99.6	90/100
		BAYHTRL123A	17.31/23.04		2	114.6/129.6 <sup>(d)</sup>	125/150
		BAYHTRL129A	21.63/28.80		2	140.7/159.6 <sup>(d)</sup>	150/175
5	TWE061D3 TWE061E3	BAYHTRL305A	3.76/5.00	208-230/3/60	1	16.1/18	20/20
		BAYHTRL310A	7.48/9.96		1	29/33	30/35
		BAYHTRL315A	11.24/14.96		1	42.2/48	45/50
		BAYHTRL325A	18.72/24.92		2	68/77.9 <sup>(d)</sup>	70/80
7½	TWE090D3 TWE090E3	BAYHTRL305A	3.76/5.00	208-230/3/60	1	19.6/21.3	25/25
		BAYHTRL310A	7.48/9.96		1	32.5/36.2	35/40
		BAYHTRL315A	11.24/14.96		1	45.7/51.2	50/60
		BAYHTRL325A	18.72/24.92		2	71.5/82 <sup>(d)</sup>	80/90
		BAYHTRL335A	26.20/34.88		2	98.7/112 <sup>(e)</sup>	100/125
10	TWE120D3 TWE120E3	BAYHTRL305A	3.76/5.00	208-230/3/60	1	21/23	25/30
		BAYHTRL310A	7.48/9.96		1	34/38	35/40
		BAYHTRL315A	11.24/14.96		1	47/53	50/60
		BAYHTRL325A	18.72/24.92		2	73/83 <sup>(d)</sup>	80/90
		BAYHTRL335A	26.20/34.88		2	98.7/113 <sup>(e)</sup>	100/125
5	TWE061D4 TWE061E4	BAYHTRL405A	5	460/3/60	1	10	15
		BAYHTRL410A	9.96		1	17	20
		BAYHTRL415A	14.96		1	25	25
		BAYHTRL425A	24.92		2	40	40
7½	TWE090D3 <sup>(f)</sup> TWE090E3 <sup>(f)</sup>	BAYHTRL405A	5	460/3/60	1	11	15
		BAYHTRL410A	9.96		1	19	20
		BAYHTRL415A	14.96		1	26	30
		BAYHTRL425A	24.92		2	41	45
		BAYHTRL435A	34.88		2	56	60

## Electrical Data

**Table 6. Unit Wiring with Electric Heat (Single Point Connection) – 5, 7½ and 10 Ton Air Handlers – 60 Hz**

Tons	Used With	Heater Model No.	Maximum Fuse Heater KW Rating <sup>(a)</sup>	Unit Power Supply	Control Stages	Minimum Circuit Ampacity <sup>(b)</sup>	Maximum Fuse or HACR Circuit Breaker Size <sup>(b)(c)</sup>
10	TWE120D3 <sup>(f)</sup> TWE120E3 <sup>(f)</sup>	BAYHTRL405A	5	460/3/60	1	12	15
		BAYHTRL410A	9.96		1	20	20
		BAYHTRL415A	14.96		1	27	30
		BAYHTRL425A	24.92		2	42	45
		BAYHTRL435A	34.88		2	57	60
5	TWE061DW	BAYHTRLW05A	5	575/3/60	1	8	15
		BAYHTRLW10A	9.96		1	15	15
		BAYHTRLW15A	14.96		1	21	20
		BAYHTRLW25A	24.92		2	33	35
7½	TWE090DW	BAYHTRLW05A	5	575/3/60	1	11	15
		BAYHTRLW10A	9.96		1	17	15
		BAYHTRLW15A	14.96		1	23	25
		BAYHTRLW25A	24.92		2	36	35
		BAYHTRLW35A	34.88		2	48	45
10	TWE120DW TWE120EW	BAYHTRLW05A	5	575/3/60	1	10	15
		BAYHTRLW10A	9.96		1	16	15
		BAYHTRLW15A	14.96		1	22	25
		BAYHTRLW25A	24.92		2	35	35
		BAYHTRLW35A	34.88		2	47	45

(a) kW ratings are at: 208/240V for 208-230V air handlers.  
480V for 460V air handlers  
600V for 575V air handlers

For other than rated voltage, capacity = (Voltage/Rated Voltage)<sup>2</sup> x Rated Capacity.

(b) Any power supply and circuits must be wired and protected in accordance with local codes.

(c) The HACR circuit breaker is for U.S.A. installations only.

(d) Field wire must be rated at least 75°C.

(e) Field wire must be rated at least 90°C.

(f) With motor field converted to 460V.

**Table 7. Unit Wiring with Electric Heat (Single Point Connection) – 12½ - 20 Ton Air Handlers**

Tons	Used With	Heater Model No.	Heater KW Rating <sup>(a)</sup>	Unit Power Supply	Control Stages	Minimum Circuit Ampacity <sup>(b)</sup>	Maximum Fuse or HACR Circuit Breaker Size <sup>(b)(c)</sup>
12½	TWE150E3	BAYHTRM310A	7.51/10.00	208-230/3/60	1	33.5/36.9	35/40
		BAYHTRM320A	14.96/19.92		1	59.3/66.8	60/70
		BAYHTRM330A	22.47/29.92		2	85.5/96.8	90/100
		BAYHTRM350A	37.44/49.84		2	137.3/156.7	150/175
15	TWE180E3	BAYHTRM310A	7.51/10.00	208-230/3/60	1	37.8/41.6	45/45
		BAYHTRM320A	14.96/19.92		1	63.7/71.4	70/80
		BAYHTRM330A	22.47/29.92		2	89.8/101.5	90/110
		BAYHTRM350A	37.44/49.84		2	141.6/161.4 <sup>(d)</sup>	150/175
20	TWE240E3	BAYHTRM310A	7.51/10.00	208-230/3/60	1	44.1/49	60/60
		BAYHTRM320A	14.96/19.92		1	71/79	80/90
		BAYHTRM330A	22.47/29.92		2	97/109	100/110
		BAYHTRM350A	37.44/49.84		2	149/169 <sup>(d)</sup>	150/175
12½	TWE150E3 <sup>(e)</sup>	BAYHTRM410A	10	460/3/60	1	19	20
		BAYHTRM420A	19.92		1	34	35
		BAYHTRM430A	29.92		2	49	50
		BAYHTRM450A	49.84		2	79	80
15	TWE180E3 <sup>(e)</sup>	BAYHTRM410A	10	460/3/60	1	21	25
		BAYHTRM420A	19.92		1	36	40
		BAYHTRM430A	29.92		2	51	60
		BAYHTRM450A	49.84		2	81	90
20	TWE240E4	BAYHTRM410A	10	460/3/60	1	24	30
		BAYHTRM420A	19.92		1	39	40
		BAYHTRM430A	29.92		2	54	60
		BAYHTRM450A	49.84		2	84	90
12½	TWE150EW	BAYHTRMW10A	10	575/3/60	1	15	15
		BAYHTRMW20A	19.92		1	27	30
		BAYHTRMW30A	29.92		2	39	40
		BAYHTRMW50A	49.84		2	63	70
15	TWE180EW	BAYHTRMW10A	10	575/3/60	1	17	20
		BAYHTRMW20A	19.92		1	30	30
		BAYHTRMW30A	29.92		2	42	45
		BAYHTRMW50A	49.84		2	67	70
20	TWE240EW	BAYHTRMW10A	10	575/3/60	1	20	25
		BAYHTRMW20A	19.92		1	32	35
		BAYHTRMW30A	29.92		2	45	45
		BAYHTRMW50A	49.84		2	70	70

(a) kW ratings are at: 208/240V for 208-230V air handlers.

480V for 460V air handlers

600V for 575V air handlers

For other than rated voltage, capacity = (Voltage/Rated Voltage)<sup>2</sup> x Rated Capacity.

(b) Any power supply and circuits must be wired and protected in accordance with local codes.

(c) The HACR circuit breaker is for U.S.A. installations only.

(d) Field wire must be rated at least 90°C.

(e) With motor field wired for 460V.

## Electrical Data

**Table 8. Electrical Characteristics – Standard Motor – 50 Hz Air Handler**

Tons	Unit Model Number	Standard Evaporator Fan Motor				
		No.	Volts	Phase	Amps	
					FLA	LRA
4.5	TWE051DD	1	380	3	1.4	8.0
		1	415	3	1.0	8.36
6.25	TWE076DD	1	380	3	3.1	17
		1	415	3	3.2	16.8
8.33	TWE101DD, ED	1	380	3	3.4	17.3
		1	415	3	3.2	19
10.4	TWE126ED	1	380	3	3.2	35
		1	415	3	3.1	35
13.0	TWE156ED	1	380	3	4.0	33.1
		1	415	3	4.0	36.1
16.7	TWE201ED	1	380	3	8.0	43.2
		1	415	3	8.0	48.6

**Table 9. Unit Wiring – Air Handler – 50 Hz**

Tons	Unit Model No.	Minimum Unit Operating Voltage Range	Maximum Fuse Circuit Ampacity	Size or Maximum Circuit Breaker
4.5	TWE051DD	380/415	4	15
6.25	TWE076DD	380/415	5	15
8.33	TWE101DD, ED	380/415	5	15
10.4	TWE126ED	380/415	5	15
13.0	TWE156ED	380/415	6	15
16.7	TWE201ED	380/415	10	15

**Table 10. Unit Wiring With Electric Heat (Single Point Connection) – Air Handlers – 50 Hz<sup>(a)(b)</sup>**

Heater Model No.	Heater kW Rating <sup>(c)</sup>	To Use with Unit	Control Stages	Minimum Circuit Ampacity <sup>(d)</sup>	Maximum Fuse Breaker Size 2
BAYHTRL405A	5.00	TWE051DD	1	13	15
BAYHTRL410A	9.96		1	22	25
BAYHTRL415A	14.96		1	31	35
BAYHTRL425A	24.92		2	49	50
BAYHTRL405A	5.00	TWE076DD	1	14	15
BAYHTRL410A	9.96		1	23	25
BAYHTRL415A	14.96		1	32	35
BAYHTRL425A	24.92		2	50	50
BAYHTRL435A	34.88		2	68	70
BAYHTRL405A	5.00	TWE101DD, TWE101ED	1	14	15
BAYHTRL410A	9.96		1	23	25
BAYHTRL415A	14.96		1	32	35
BAYHTRL425A	24.92		2	50	50
BAYHTRL435A	34.88		2	68	70
BAYHTRM410A	10.00	TWE126ED	1	19	20
BAYHTRM420A	19.92		1	41	45
BAYHTRM430A	24.92		2	59	60
BAYHTRM450A	49.84		2	94	100
BAYHTRM410A	10.00	TWE156ED	1	23	25
BAYHTRM420A	19.92		1	41	45
BAYHTRM430A	24.92		2	59	60
BAYHTRM450A	49.84		2	95	100
BAYHTRM410A	10.00	TWE201ED	1	29	30
BAYHTRM420A	19.92		1	46	50
BAYHTRM430A	24.92		2	65	70
BAYHTRM450A	49.84		2	100	100

(a) Field wire must be rated at least 167°F (75°C).

(b) Field wire must be rated at least 194°F (90°C).

(c) kW ratings are at 400v for 3 phase, 400v air handlers

For other than rated voltage,

Capacity = (Voltage/Rated Voltage)<sup>2</sup> x Rated Capacity and kW = (Voltage/Rated Voltage)<sup>2</sup> Rated kW.

(d) Any power supply and circuits must be wired and protected in accordance with local codes. MCA and Maximum Fuse Size is based on 400V.

# Installation

## Horizontal Suspension

If the air handler will be suspended, use a suspension mounting kit to isolate the unit from the structure. This is usually accomplished through the use of spring or rubber isolators, which are offered as an accessory. Mounting rods must be field supplied. Isolator selection is dependent upon total unit weight including accessories. Approximate unit weights are provided in [Table 1](#) and [Table 2, p. 7](#).

### **NOTICE**

#### **Equipment Damage!**

**Before hanging the unit on suspension rods, reinforce the cabinet around the suspension holes by using a large washer inside the cabinet. Washers should be between the skin of the air handler and the nut on the suspension rod.**

Align holes in the cabinet with structural supports and secure suspension rods to the structure, then to the air handler cabinet. If hole locations do not permit proper alignment with existing structure, it may be necessary to field fabricate cross members on existing structural beams.

**Note:** *When other than bottom return is to be used, side panel removed for return duct installation must be secured over the bottom opening.*

### **Leveling**

This air handler has a double sloped drain pan. In order to assure proper drainage along the length of the drain pan, it is important to have the unit properly leveled. Be sure the air handler is level.

### **Auxiliary Drain Pan**

A field fabricated, auxiliary drain pan should be installed under the unit for all horizontal applications and when air handlers are installed above ceilings or in other locations where condensate overflow may cause damage. This drain pan will eliminate any excess condensation that may be due to extreme humidity or an obstructed drain in the primary drain pan. Drain lines from this pan must be installed, but should not be connected to the primary drain line from the unit. Isolate the auxiliary drain pan from both the air handler and the structure.



### **WARNING**

#### **Fiberglass Wool!**

**Product contains fiberglass wool. Disturbing the insulation in this product during installation, maintenance or repair will expose you to airborne particles of glass wool fibers and ceramic fibers known to the state of California to cause cancer through inhalation. Glass wool fibers may also cause respiratory, skin or eye irritation.**

### **Precautionary Measures**

- Avoid breathing fiberglass dust.
- Use a NIOSH approved dust/mist respirator.
- Avoid contact with the skin or eyes. Wear long-sleeved, loose-fitting clothing, gloves, and eye protection.
- Wash clothes separately from other clothing: rinse washer thoroughly.

- Operations such as sawing, blowing, tear-out, and spraying may generate fiber concentrations requiring additional respiratory protection. Use the appropriate NIOSH approved respirator in these situations.

### First Aid Measures

**Eye Contact - Flush eyes with water to remove dust. If symptoms persist, seek medical attention.**

**Skin Contact - Wash affected areas gently with soap and warm water after handling.**

## Refrigerant Piping

Installation, brazing, leak testing and evacuation of refrigerant lines are covered in the installation instructions packaged with the outdoor unit. Read the instructions before beginning installation of refrigerant lines.

Locate cloth bag(s) attached to the refrigerant tube of the coil that contains a stainless steel clamp and insulation material (approximately 9" long by 4" wide) for each refrigerant circuit. This is for attaching and insulating the expansion valve bulb (s) to the suction line(s).

On air handlers that will have refrigerant lines entering the cabinet from the left side, remove the split rubber grommet from the knockout in the end of the air handler. Uncoil the cap tube with the bulb attached at the expansion valve and place the grommet on the cap tube. With the grommet around the tube, push the bulb through the hole and position the grommet back into its original position (one bulb and cap tube on single circuit units and two bulbs and cap tubes on dual circuit units).

Attach the bulb(s) on a horizontal section of tube where the entire length of the bulb is in contact with the tube, (see [Figure 14, p. 31](#)) approximately 45 degrees off vertical (a 10 or 2 o'clock position), 10 to 12 inches outside of the air handler.

On air handlers that will have refrigerant lines entering the cabinet from the right side, the bulb(s) should be attached to the suction tube(s) inside the cabinet in the same manner as above, approximately 10" from the right end of the unit.

After attaching to the suction line(s), either inside or outside of the cabinet, wrap the insulation around the bulb(s) and suction tube(s). Refrigerant piping should be insulated.

**Figure 14. Remote Bulb Installation**

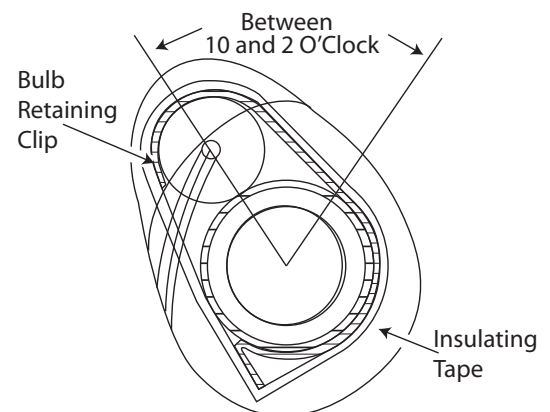

### NOTICE

#### Equipment Damage!

**Ensure that the refrigerant lines passing through the cabinet are not resting on sharp sheet metal edges and that the bulb(s) are attached to the suction line of the same circuit.**

### Condensate Piping

The drain pan condensate connection is a female slip joint type for 1" Schedule 40 PVC pipe. Use PVC cement and tubing as required (field supplied) to construct a trap. A union or flexible tubing and clamps may be installed if the drain pan is to be removed periodically for cleaning.

**Important:** When air handler is installed in the vertical position and close proximity trapping of condensate is required, use of a subbase accessory to raise the air handler for clearance of the drain trap is recommended. See Figure 15 for a typical drain trap assembly.

Figure 15. Typical Drain Trap Assembly

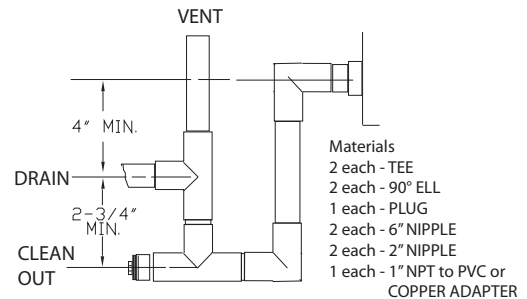

### Filters

Air handlers are shipped with throwaway filters installed. For replacement filters consult the air handler service facts for correct size and number.

To replace filters from the end of the unit, remove lower access panel (either end) and slide old filters out and replace with new ones. To replace from the front of the unit, remove one "L" shaped angle. Remove and replace filters and reinstall "L" shaped angle. See Figure 16.

To convert from 1" filter to a 2" filter on units so equipped, remove lower access panels from both ends of the air handler. Remove screws and rotate the "L" shaped angles from both the top and bottom of the filter track 180° to increase the width of the filter opening.

Figure 16. Filter Replacement

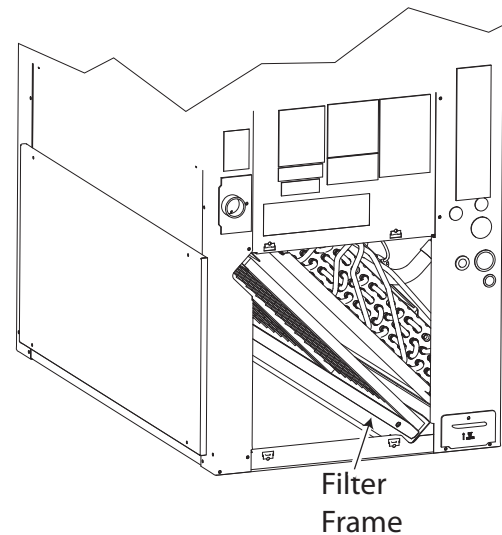

### Duct Connections

The supply and return ducts should be connected to the unit with flame retardant duct connectors to reduce vibration transmission. The return duct should be sized to the same dimensions as the return inlet of the unit.

**Important:** Duct flanges are provided for attachment of the duct work and are packaged on the outside of the cabinet for TWE150, 180 and 240 and TWE126, 156 and 201. The duct flanges are fastened to the top coil support bracket in the TWE051, 061, 076, 090, 101 and 120 models.

### Air Flow Settings

Unit is shipped for nominal airflow with nominal static pressure. Please refer to fan performance table in either the product catalog or unit service facts and select the proper drive package for each application. Failure to do so could result in improper airflow causing coil frosting or condensate management problems. Condensate management problems such as water blow off could be the

result of too great of air face velocity across the coil. To ensure proper operation refer to fan belt adjustment procedures, p. 38.

## Electrical Connections

### **⚠️ WARNING**

#### **Hazardous Voltage w/Capacitors!**

Disconnect all electric power, including remote disconnects and discharge all motor start/run capacitors before servicing. Follow proper lockout/tagout procedures to ensure the power cannot be inadvertently energized. For variable frequency drives or other energy storing components provided by Trane or others, refer to the appropriate manufacturer's literature for allowable waiting periods for discharge of capacitors. Verify with an appropriate voltmeter that all capacitors have discharged. Failure to disconnect power and discharge capacitors before servicing could result in death or serious injury.

### **⚠️ WARNING**

#### **Grounding Required!**

Follow proper local and state electrical code on requirements for grounding. Failure to follow code could result in death or serious injury.

1. All electrical lines, sizing, protection, and grounding must be in accordance with the National Electric Code and local codes.
2. Isolate conduit whenever vibration transmission may cause a noise problem within the building structure.
3. Ensure all connections are tight and no wires exposed.
4. All accessories must be installed and wired according to the instructions packaged with that accessory.

For air handler power entry only, or for dual power entry (power entry for air handler and power entry for electric heats), the electrical connections are made in the fan control box located in the right side of the air handler and electric heater respectively. Wiring entrance is through holes provided in the end of the air handler cabinet, Figure 17. Breaker or fuse size can be selected using the nameplates attached to the unit and electric heater (see Table 6, p. 25).

**Figure 17. Electrical Entries**

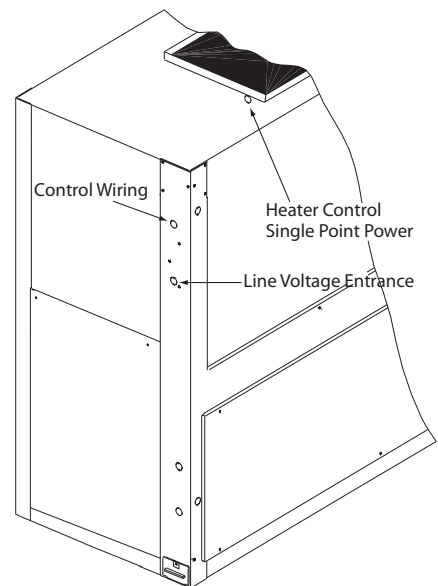

**Table 11. Recommended T'stat Wire Size**

Wire Size (Gauge)	Maximum Wire Length Physical distance between Unit & T'stat
22	30 Feet
20	50 Feet
18	75 Feet
16	125 Feet
14	200 Feet

### Checkout Procedure

Complete the following "installation checklist" once installation of field wiring connections is complete. All operational checks (unit running) must be made after the outdoor unit is installed and system interconnection is complete.

### Installation Checklist

#### **WARNING** **Hazardous Voltage!**

**Disconnect all electric power, including remote disconnects before servicing. Follow proper lockout/tagout procedures to ensure the power can not be inadvertently energized. Failure to disconnect power before servicing could result in death or serious injury.**

Complete this checklist once the unit is installed to verify that all recommended procedures have been accomplished before the system is started. Operational checks cannot be performed until the outdoor unit is installed and system interconnection is complete.

1. Verify that the unit electrical power is disconnected.
2. Inspect all field wiring connections. All connections should be clean and tight.
3. Inspect unit ground connection(s). Ground must comply with all applicable codes.
4. Inspect unit suspension arrangement (if used). Unit position must be secure. Remove any tools or debris found in or near the unit.
5. Inspect duct outlets. Outlets must be open and unrestricted.
6. Inspect unit drain lines. Pipe connections must be tight and drain line unrestricted.
7. Inspect fan assembly to insure all moving parts move freely.
8. If unit is horizontally mounted, make sure secondary drain pan has been installed.
9. Inspect unit for proper filters, securely installed and not touching the coil surface. All cabinet panels must be secure.
10. Instruct owner/operator on proper system operating and maintenance procedure.

### Electrical Wiring

#### **WARNING** **Hazardous Voltage w/Capacitors!**

**Disconnect all electric power, including remote disconnects and discharge all motor start/run capacitors before servicing. Follow proper lockout/tagout procedures to ensure the power cannot be inadvertently energized. For variable frequency drives or other energy storing components provided by Trane or others, refer to the appropriate manufacturer's literature for allowable waiting periods for discharge of capacitors. Verify with an appropriate voltmeter that all capacitors have discharged. Failure to disconnect power and discharge capacitors before servicing could result in death or serious injury.**

**Note:** For additional information regarding the safe discharge of capacitors, see PROD-SVB06A-EN or PROD-SVB06A-FR

**⚠ WARNING**  
**Grounding Required!**

Follow proper local and state electrical code on requirements for grounding. Failure to follow code could result in death or serious injury.

**Thermostat and Control Connections for Electromechanical Controls**

Wiring shown with dashed lines is to be furnished and installed by the customer. All customer-supplied wiring must be copper only and must conform to NEC and local electrical codes. Codes may require line of sight between disconnect switch and unit.

1. Observe all notes on the wiring diagrams.
2. Mount the thermostat in the desired location.
3. Install color coded low voltage cables between outdoor unit, indoor unit and thermostat.
4. Connect low voltage control wiring to the low voltage terminal board located on the side of the fan control box per the typical interconnecting wiring diagrams.

**Note:** When electric heater accessory is used, single point power entry or dual point power entry is field optional. Single point power entry option is through electric heater only.

**Figure 18. Thermostat and Control Connections – Electromechanical Controls**

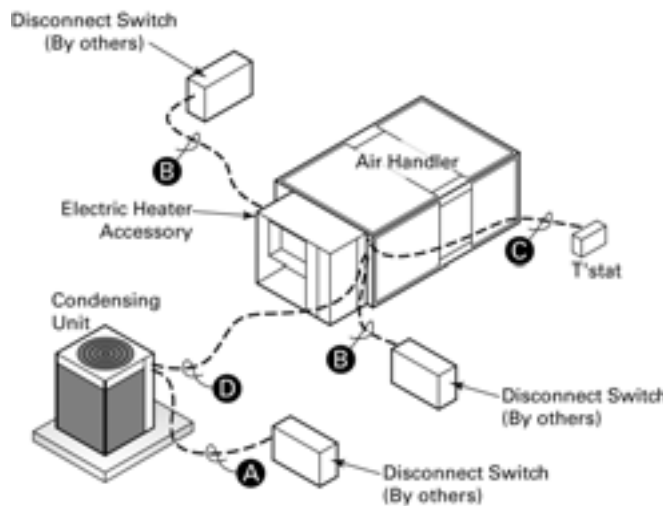

**60 Hz - TTA/TWE**

TTA073D/TWE090D  
 TTA090D/TWE090D  
 TTA090D/TWE120D  
 TTA120D/TWE120D  
 TTA120E/TWE120E  
 TTA120F/TWE120D

TTA150E/TWE150E  
 TTA180E/TWE180E  
 TTA180F/TWE180E<sup>(a)</sup>  
 TTA180E/TWE240E  
 TTA240E/TWE240E  
 TTA240F/TWE240E<sup>(a)</sup>

(2) TTA073D/TWE150E  
 (2) TTA090D/TWE180E  
 (2) TTA120D/TWE240E  
 (2) TTA120F/TWE240E

**50 Hz - TTA/TWE**

TTA061DD/TWE076DD  
 TTA076DD/TWE076DD  
 TTA076DD/TWE101DD  
 TTA086DD/TWE101DD  
 TTA101DD/TWE101DD  
 TTA101ED/TWE101ED

TTA101FD/TWE101DD  
 TTA126ED/TWE126ED  
 TTA156ED/TWE156ED  
 TTA156FD/TWE156ED<sup>(a)</sup>  
 TTA156ED/TWE201ED  
 TTA201ED/TWE201ED

TTA201FD/TWE201ED<sup>(a)</sup>  
 (2) TTA061DD/TWE126ED  
 (2) TTA076DD/TWE156ED  
 (2) TTA101DD/TWE201ED  
 (2) TTA101FD/TWE201ED

(a) Need to manifold the dual circuit indoor unit when connecting to a Manifolded outdoor unit.

### **Field Wiring:**

- A. 3 power wires. Line voltage for 3 phase (2 wires for single phase)
- B. 3 power wires. Line voltage for 3 phase (2 wires for single phase)
- C. **Cooling only thermostat:** 3 to 7 wires depending on stages of electric heat
- D. 3 to 7 wires depending on type of outdoor unit(s)

## **Thermostat and Control Connections for ReliaTel™ Controls**

Wiring shown with dashed lines is to be furnished and installed by the customer. All customer-supplied wiring must be copper only and must conform to NEC and local electrical codes. Codes may require line of sight between disconnect switch and unit.

1. Observe all notes on the wiring diagrams.
2. Mount the thermostat in the desired location.
3. Install color coded low voltage cables between outdoor unit, indoor unit and thermostat.
4. Connect low voltage control wiring to the low voltage terminal board located on the side of the fan control box per the typical interconnecting wiring diagrams.

### **Notes:**

1. When electric heater accessory is used, single point power entry or dual point power entry is field optional. Single point power entry option is through electric heater only.
2. \*\*\*Choose only one of the following; Thermostat, Zone Sensor, or NSB Panel.

**Figure 19. Thermostat and Control Connections — ReliaTel™ Controls**

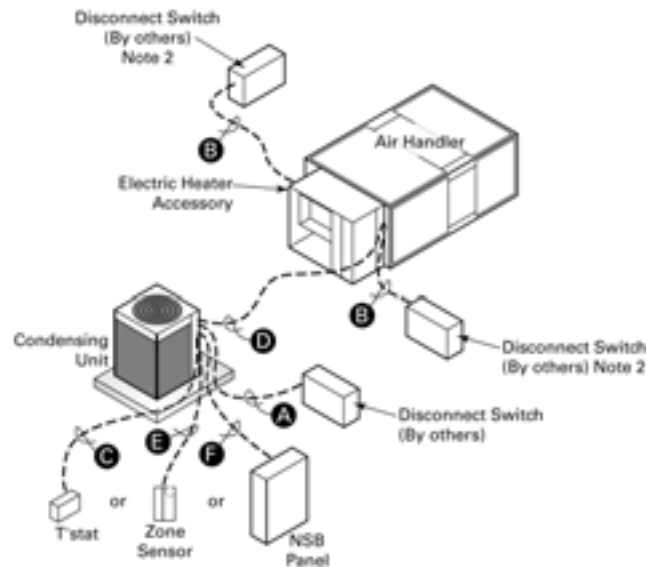

**60 Hz - TTA/TWE**

TTA073D/TWE090D	TTA150E/TWE150E	(2) TTA073D/TWE150E
TTA090D/TWE090D	TTA180E/TWE180E	(2) TTA090D/TWE180E
TTA090D/TWE120D	TTA180F/TWE180E <sup>(a)</sup>	(2) TTA120D/TWE240E
TTA120D/TWE120D	TTA180E/TWE240E	(2) TTA120F/TWE240E
TTA120E/TWE120E	TTA240E/TWE240E	
TTA120F/TWE120D	TTA240F/TWE240E <sup>(a)</sup>	

**50 Hz - TTA/TWE**

TTA061DD/TWE076DD	TTA101FD/TWE101DD	TTA201FD/TWE201ED <sup>(a)</sup>
TTA076DD/TWE076DD	TTA126ED/TWE126ED	(2) TTA061DD/TWE126ED
TTA076DD/TWE101DD	TTA156ED/TWE156ED	(2) TTA076DD/TWE156ED
TTA086DD/TWE101DD	TTA156FD/TWE156ED <sup>(a)</sup>	(2) TTA101DD/TWE201ED
TTA101DD/TWE101DD	TTA156ED/TWE201ED	(2) TTA101FD/TWE201ED
TTA101ED/TWE101ED	TTA201ED/TWE201ED	

**60 Hz - TWA/TWE**

TWA073D/TWE090D	TWA180E/TWE180E	(2) TWA090D/TWE180E
TWA090D/TWE090D	TWA240E/TWE240E	(2) TWA120D/TWE240E
TWA120D/TWE120D	(2) TWA073D/TWE150E	

**50 Hz - TWA/TWE**

TWA061DD/TWE076DD	TWA101DD/TWE101DD	TWA201ED/TWE201ED
TWA076DD/TWE076DD	TWA156ED/TWE156ED	

(a) Need to manifold the dual circuit indoor unit when connecting to a Manifolded outdoor unit.

**Field Wiring:**

- A. 3 power wires, line voltage for 3 phase, (2 power wires for single phase)
- B. 3 power wires, line voltage for 3 phase, (2 power wires for single phase)
- C. **Cooling only thermostat:** 3 to 7 wires depending on stages of electric heat  
**Zone Sensor:** 4 to 10 wires depending on zone sensor model <sup>1</sup>
- D. 3 to 7 wires depending on type of outdoor unit(s).

<sup>1</sup> See Zone Sensor wiring instructions for wiring information (ReliaTel Controls only).

# Maintenance

Perform all of the indicated maintenance procedures at the intervals scheduled. This will prolong the life of the unit and reduce the possibility of costly equipment failure.

## Fan Belt Adjustment

### **WARNING**

#### **Rotating Components!**

**Disconnect all electric power, including remote disconnects before servicing. Follow proper lockout/tagout procedures to ensure the power can not be inadvertently energized. Failure to disconnect power before servicing could result in death or serious injury.**

The fan belts must be inspected periodically to assure proper unit operation.

Replacement is necessary if the belts appear frayed or worn.

When removing or installing the new belts, do not stretch them over the sheaves. Loosen the belts using the belt tension adjustment bolts on the motor mounting base.

Once the new belts are installed, using a Browning or Gates tension gauge (or equivalent) illustrated in [Figure 20](#); adjust the belt tension as follows;

1. To determine the appropriate belt deflection;
  - a. Measure the center-to-center shaft distance (in inches) between the fan and motor sheaves.
  - b. Divide the distance measured in Step 1a by 64; the resulting value represents the amount of belt deflection that corresponds to the proper belt tension.
2. Set the large O-ring on the belt tension gauge at the deflection value determined in Step 1b.
3. Set the small O-ring at zero on the force scale of the gauge plunger.
4. Place the large end of the gauge at the center of the belt span; then depress the gauge plunger until the large O-ring is even with the top of the next belt or even with a straightedge placed across the fan and motor sheaves.
5. Remove the belt tension gauge. The small O-ring now indicates a number other than zero on the plunger's force scale. This number represents the force (in pounds) required to give the needed deflection.
6. Compare the "force" scale reading (Step 5) with the appropriate "force" value listed in [Table 12, p. 39](#). If the "force" reading is outside the range, readjust the belt tension.

**Note:** Actual belt deflection "force" must not exceed the maximum "force" value shown in [Figure 20](#).

Recheck the belt tension at least twice during the first 2 to 3 days of operation. Belt tension may decrease until the new belts are "run in".

**Figure 20. Belt tension gauge**

$$\text{Deflection} = \frac{\text{Belt Span (in)}}{64}$$

$$\text{Deflection} = \frac{\text{Belt Span (mm)}}{152}$$

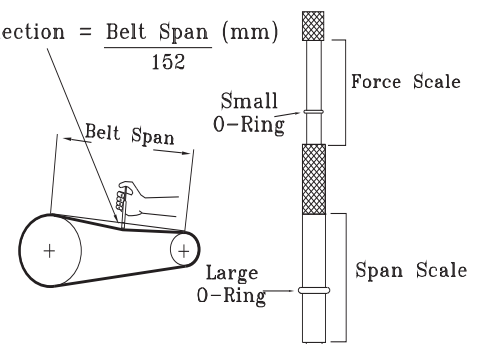

**Table 12. Belt Tension Measurement and Deflection**

Belts Cross Section	Small Pitch Diameter Range	Deflection Force (Lbs.)			
		Standard V-Belt		V-Belt with Molded Notches	
		Min.	Max.	Min.	Max.
A	3.0 - 3.6	3	4 1/2	3 7/8	5 1/2
	3.8 - 4.8	3 1/2	5	4 1/2	6 1/4
	5.0 - 7.0	4	5 1/2	5	6 7/8
B	3.4 - 4.2	4	5 1/2	5 3/4	8
	4.4 - 5.6	5 1/8	7 1/8	6 1/2	9 1/8
	5.8 - 8.8	6 3/8	8 3/4	7 3/8	10 1/8

## Monthly

Conduct the following maintenance inspections once per month.

The following warning complies with State of California law, Proposition 65.

### **WARNING**

#### **Fiberglass Wool!**

Product contains fiberglass wool. Disturbing the insulation in this product during installation, maintenance or repair will expose you to airborne particles of glass wool fibers and ceramic fibers known to the state of California to cause cancer through inhalation. Glass wool fibers may also cause respiratory, skin or eye irritation.

### **WARNING**

#### **Hazardous Voltage w/Capacitors!**

Disconnect all electric power, including remote disconnects and discharge all motor start/run capacitors before servicing. Follow proper lockout/tagout procedures to ensure the power cannot be inadvertently energized. For variable frequency drives or other energy storing components provided by Trane or others, refer to the appropriate manufacturer's literature for allowable waiting periods for discharge of capacitors. Verify with an appropriate voltmeter that all capacitors have discharged. Failure to disconnect power and discharge capacitors before servicing could result in death or serious injury.

### **NOTICE**

#### **Operating Under Vacuum**

**Do not operate or apply power to the compressor while under a vacuum. Failure to follow these instructions will result in compressor failure.**

1. Inspect air filters and clean (or replace) if necessary.
2. Check unit wiring to ensure all connections are tight and that the wiring insulation is intact.
3. Check drain pans and condensate piping to insure they are free of obstacles.
4. Manually rotate the indoor fan to ensure proper operation.
5. Inspect the evaporator coils for dirt and debris. If the coils appear dirty, clean them.
6. Observe indoor fan operation and correct any unusual or excessive vibration. Clean blower wheels as needed.

### Annually (Cooling Season)

The following maintenance procedures must be performed at the beginning of each cooling season to ensure efficient unit operation.

1. Perform all of the monthly maintenance inspections.
2. With the unit operating, check unit superheat and record the reading in the "Maintenance Log."
3. Remove any accumulation of dust and/or dirt from the unit casing.
4. Remove corrosion from any surface and repaint. Check the gasket around the control panel door to ensure it fits correctly and is in good condition to prevent water leakage.
5. Inspect the evaporator fan belt. If it is worn or frayed, replace it.
6. Inspect the control panel wiring to ensure that all connections are tight and that the insulation is intact.
7. Check refrigerant piping and fittings for leaks.
8. Inspect the evaporator coils for dirt and debris. If the coils appear dirty, clean them.

### Coil Cleaning

Regular coil maintenance, including annual cleaning-enhances the unit's operating efficiency by minimizing:

- compressor head pressure and amperage draw;
- water carryover;
- fan brake horsepower and
- static pressure losses.

At least once each year-or more often if the unit is located in a "dirty" environment-clean the coil using the instructions outlined below. Be sure to follow these instructions as closely as possible to avoid damaging the coils. To clean refrigerant coils, use a soft brush and a sprayer. Contact your local Parts Center for appropriate detergents.

1. Remove enough panels from the unit to gain safe access to coil.

#### **WARNING**

#### **No Step Surface!**

**Do not walk on the sheet metal base. Walking on the base could cause the supporting metal to collapse. Failure of the base could result in death or serious injury.**

2. Straighten any bent coil fins with a fin comb.
3. Remove loose dirt and debris from both sides of the coil with a soft brush.
4. Mix the detergent with water according to the manufacturer's instructions. If desired, heat the solution to 150° F maximum to improve its cleansing capability.
5. Pour the cleaning solution into the sprayer.
6. Spray the leaving-airflow side of the coil first; then spray the opposite side of the coil. Allow the cleaning solution to stand on the coil for five minutes.
7. Rinse both sides of the coil with cool, clean water.
8. Inspect both sides of the coil; if it still appears to be dirty, repeat Steps 7 and 8.
9. Reinstall all of the components and panels removed in Step 1; then restore power to the unit.
10. Using a fin comb, straighten any coil fins that were inadvertently bent during the cleaning process.

## Precautionary Measures

- Avoid breathing fiberglass dust.
- Use a NIOSH approved dust/mist respirator.
- Avoid contact with the skin or eyes. Wear long-sleeved, loose-fitting clothing, gloves, and eye protection.
- Wash clothes separately from other clothing: rinse washer thoroughly.
- Operations such as sawing, blowing, tear-out, and spraying may generate fiber concentrations requiring additional respiratory protection. Use the appropriate NIOSH approved respirator in these situations.

## First Aid Measures

***Eye Contact - Flush eyes with water to remove dust. If symptoms persist, seek medical attention.***

***Skin Contact - Wash affected areas gently with soap and warm water after handling.***



# Warranty

## Central Air Conditioner

TWE

This warranty is extended by Trane to the original purchaser and to any succeeding owner of the real property to which the Air Conditioner is originally affixed, and applies to products purchased and retained for use within the U.S.A. and Canada. There is no warranty against corrosion, erosion or deterioration.

Warrantor warrants for a period of 12 months from initial start-up or 18 months from date of shipment, whichever is less, that the products covered by this warranty (1) are free from defects in material and manufacture, and (2) have the capacities and ratings set forth in catalogs and bulletins; provided, that no warranty is made against corrosion, erosion or deterioration.

Warrantor's obligations and liabilities under this warranty are limited to furnishing, F.O.B. factory replacement parts (or equipment at the option of Warrantor) for all Warrantor's products not conforming to this warranty. Warrantor shall not be obligated to pay for the cost of lost refrigerant. No liability whatever shall attach to Warrantor until said products have been paid for and then said liability shall be limited to the purchase price of the equipment shown to be defective.

THE WARRANTY AND LIABILITY SET FORTH HEREIN ARE IN LIEU OF ALL OTHER WARRANTIES AND LIABILITIES, WHETHER IN CONTRACT OR IN NEGLIGENCE, EXPRESS OR IMPLIED, IN LAW OR IN FACT, INCLUDING IMPLIED WARRANTIES OF MERCHANTABILITY AND FITNESS FOR PARTICULAR USE, AND IN NO EVENT SHALL WARRANTOR BE LIABLE FOR ANY INCIDENTAL OR CONSEQUENTIAL DAMAGES.

Some states do not allow limitations on how long an implied warranty lasts or do not allow the exclusion or limitation of incidental or consequential damages, so the above limitation or exclusion may not apply to you. This warranty gives you specific legal rights, and you may also have other rights which vary from state to state.

Trane, 2701 Wilma Rudolph Blvd., Clarksville, TN 37040-1008

Attention: Manager, Product Service

TW-338-0597

\* This warranty is for commercial usage of said equipment and not applicable when the equipment is used for a residential application. Commercial use is any application where the end purchaser uses the product for other than personal, family or household purposes.

## Commercial Equipment Rated 20 Tons and Larger and Related Accessories (Parts Only)

**Products Covered** — This warranty is extended by Trane and applies only to commercial equipment rated 20 tons and larger and related accessories purchased and retained for use within the U.S.A. and Canada.

Warrantor warrants for a period of 12 months from initial start-up or 18 months from date of shipment, whichever is less, that the products covered by this warranty (1) are free from defects in material and manufacture, and (2) have the capacities and ratings set forth in catalogs and bulletins; provided, that no warranty is made against corrosion, erosion or deterioration.

Warrantor's obligations and liabilities under this warranty are limited to furnishing, F.O.B. factory replacement parts (or equipment at the option of Warrantor) for all Warrantor's products not conforming to this warranty. Warrantor shall not be obligated to pay for the cost of lost refrigerant. No liability whatever shall attach to Warrantor until said products have been paid for and then said liability shall be limited to the purchase price of the equipment shown to be defective.

## Warranty

---

THE WARRANTY AND LIABILITY SET FORTH HEREIN ARE IN LIEU OF ALL OTHER WARRANTIES AND LIABILITIES, WHETHER IN CONTRACT OR IN NEGLIGENCE, EXPRESS OR IMPLIED, IN LAW OR IN FACT, INCLUDING IMPLIED WARRANTIES OF MERCHANTABILITY AND FITNESS FOR PARTICULAR USE, AND IN NO EVENT SHALL WARRANTOR BE LIABLE FOR ANY INCIDENTAL OR CONSEQUENTIAL DAMAGES.

Some states do not allow limitations on how long an implied warranty lasts or do not allow the exclusion or limitation of incidental or consequential damages, so the above limitation or exclusion may not apply to you. This warranty gives you specific legal rights, and you may also have other rights which vary from state to state.

Trane —Warrantor, 2701 Wilma Rudolph Blvd., Clarksville, TN 37040

GW-598-4799

# Wiring Diagram Matrix

DIAGRAM NO.	DIAGRAM TYPE	UNIT MODEL NO'S
2313-0401	Power/Control Diagram	TWE051DD00AA, TWE061D300AA, TWE061D400AA, TWE061DK00AA, TWE061DW00AA, TWE076DD00AA, TWE090D300AA, TWE090DK00AA, TWE090DW00AA, TWE101DD00AA, TWE120D300AA, TWE120DK00AA, TWE120DW00AA
2313-0402	Power/Control Diagram	TWE061D100AA, TWE090D100AA, TWE120D100AA
2313-0431	Power/Control Diagram	TWE061E300AA, TWE061E400AA, TWE090E300AA, TWE0101ED00AA, TWE120E300AA, TWE120EK00AA, TWE120EW00AA, TWE126ED00AA, TWE150E300AA, TWE150EK00AA, TWE150EW00AA, TWE156ED00AA, TWE180E300AA, TWE180EK00AA, TWE180EW00AA, TWE201ED00AA, TWE240E300AA, TWE240E400AA, TWE240EK00AA, TWE240EW00AA
2313-0432	Power/Control Diagram	TWE061E100AA, TWE090E100AA, TWE120E100AA

**Note:** Wiring diagrams are available through e-Library or by contacting your local sales office

The manufacturer optimizes the performance of homes and buildings around the world. A business of Ingersoll Rand, the leader in creating and sustaining safe, comfortable and energy efficient environments, the manufacturer offers a broad portfolio of advanced controls and HVAC systems, comprehensive building services, and parts. For more information, visit [www.IRCO.com](http://www.IRCO.com).

The manufacturer has a policy of continuous product and product data improvement and reserves the right to change design and specifications without notice.

© 2011 Trane All rights reserved  
SSA-SVX06A-EN 31 Mar 2011  
Supersedes SSA-SVX06A-EN (Nov 2009)

