

4.6 PARKING AND PASSENGER LOADING ZONES.

4.6.1 MINIMUM NUMBER. PARKING SPACES REQUIRED TO BE ACCESSIBLE BY 4.1 SHALL COMPLY WITH 4.6.2 THROUGH 4.6.4. PASSENGER LOADING ZONES REQUIRED TO BE ACCESSIBLE BY 4.1 SHALL COMPLY WITH 4.6.5 AND 4.6.6.

4.6.2 LOCATION. ACCESSIBLE PARKING SPACES SERVING A PARTICULAR BUILDING SHALL BE LOCATED ON THE SHORTEST ACCESSIBLE ROUTE OF TRAVEL FROM ADJACENT PARKING TO AN ACCESSIBLE ENTRANCE. THAT DO NOT SERVE AS PARKING ZONES, ACCESSIBLE ROUTE OF TRAVEL TO AN ACCESSIBLE ENTRANCE OF THE BUILDING, ACCESSIBLE ENTRANCES WITH ADJACENT PARKING, ACCESSIBLE PARKING SPACES SHALL BE DESIGNATED AND LOCATED CLOSEST TO THE ACCESSIBLE ENTRANCES.

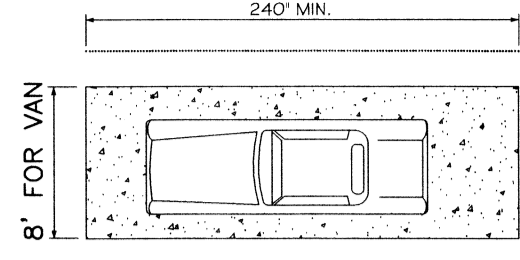

FIG. 10
ACCESS AISLE AT PASSENGER LOADING ZONES
N.T.S.

4.6.3 PARKING SPACES. PARKING SPACES FOR DISABLED PEOPLE SHALL BE AT LEAST 9'6" (2940 mm) WIDE AND SHALL HAVE AN ADJACENT ACCESS AISLE 6'0" (1829 mm) WIDE MINIMUM. PARKING ACCESS AISLES SHALL BE PART OF AN ACCESSIBLE ROUTE TO THE BUILDING OR FACILITY ENTRANCE AND SHALL COMPLY WITH 4.3. TWO ACCESSIBLE PARKING SPACES MAY SHARE A COMMON ACCESS AISLE. PARKING VEHICLE OPENINGS SHALL NOT REDUCE THE CLEAR WIDTH OF AN ACCESSIBLE CIRCULATION ROUTE. PARKING SPACES AND ACCESS AISLES SHALL BE LEVEL WITH SURFACE SLOPES NOT EXCEEDING 1:50 IN ALL DIRECTIONS.

EXCEPTION: IF ACCESSIBLE PARKING SPACES FOR VANS DESIGNED FOR HANDICAPPED PERSONS ARE PROVIDED, EACH SHOULD HAVE AN ADJACENT ACCESS AISLE AT LEAST 9'6" (2940 mm) WIDE COMPLYING WITH 4.5, GROUND AND FLOOR SURFACES.

4.6.4 SIGNAGE. ACCESSIBLE PARKING SPACES SHALL BE DESIGNATED AS RESERVED FOR THE DISABLED BY A SIGN SHOWING THE SYMBOL OF ACCESSIBILITY (SEE 4.30.5). SUCH SIGNS SHALL NOT BE OBTURED BY A VEHICLE PARKED IN THE SPACE.

4.6.5 PASSENGER LOADING ZONES. PASSENGER LOADING ZONES SHALL PROVIDE AN ACCESS AISLE AT LEAST 6'0" (1829 mm) WIDE AND 20" (508 mm) HIGH LONG ADJACENT AND PARALLEL TO THE VEHICLE PULL-UP SPACE (SEE FIG. 10). IF THERE ARE CURBS BETWEEN THE ACCESS AISLE AND THE VEHICLE PULL-UP SPACE, THEN A CURB RAMP COMPLYING WITH 4.7 SHALL BE PROVIDED. VEHICLE STANDING SPACES AND ACCESS AISLES SHALL BE LEVEL WITH SURFACE SLOPES NOT EXCEEDING 1:50 IN ALL DIRECTIONS.

4.6.6 VERTICAL CLEARANCE. PASSENGER LOADING ZONES SHALL PROVIDE AN ACCESS AISLE AT LEAST 6'0" (1829 mm) WIDE AND 20" (508 mm) HIGH LONG ADJACENT AND PARALLEL TO THE VEHICLE PULL-UP SPACE (SEE FIG. 10). IF THERE ARE CURBS BETWEEN THE ACCESS AISLE AND THE VEHICLE PULL-UP SPACE, THEN A CURB RAMP COMPLYING WITH 4.7 SHALL BE PROVIDED. VEHICLE STANDING SPACES AND ACCESS AISLES SHALL BE LEVEL WITH SURFACE SLOPES NOT EXCEEDING 1:50 (2% IN ALL DIRECTIONS).

4.7 CURB RAMPS.

4.7.1 LOCATION. CURB RAMPS COMPLYING WITH 4.7 SHALL BE PROVIDED WHEREVER AN ACCESSIBLE ROUTE CROSSES A CURB.

4.7.2 SLOPE. SLOPES OF CURB RAMPS SHALL COMPLY WITH 4.8.2. THE SLOPE SHALL BE MEASURED AS IN FIG. 11. TRANSITIONS FROM RAMPS TO WALKWAYS, GROUND, OR CURBS SHALL BE FLUSH AND FREE OF ABRUPT CHANGES. MAXIMUM SLOPES OF ADJACENT CURBS, ROAD SURFACES IMMEDIATELY ADJACENT TO THE CURB RAMP, OR ACCESSIBLE ROUTE SHALL NOT EXCEED 1:20.

4.7.3 WIDTH. THE MINIMUM WIDTH OF A CURB RAMP SHALL BE 36" (915 mm) OF FLARED SIDES.

4.7.4 SURFACE. SURFACES OF CURB RAMPS SHALL COMPLY WITH 4.5.

4.7.5 SIDES OF CURB RAMPS. IF A CURB RAMP IS LOCATED WHERE PEDESTRIANS MUST WALK ACROSS THE RAMP, OR WHERE IT IS NOT PROTECTED BY HANDRAILS OR GUARDRAILS, THEN IT SHALL HAVE FLARED SIDES. THE MINIMUM SLOPE OF THE FLARED SIDES SHALL BE 1:12. CURB RAMPS WITH RETURNED CURBS MAY BE USED WHERE PEDESTRIANS WOULD NOT NORMALLY WALK ACROSS THE RAMP (SEE FIG. 12B).

4.7.6 BUILT-UP CURB RAMPS. BUILT-UP CURB RAMPS SHALL BE LOCATED SO THAT THEY DO NOT PROJECT INTO VEHICULAR TRAFFIC LANES (SEE FIG. 13).

4.7.7 WARNING TEXTURES. (REMOVED & RESERVED.)

4.7.8 OBSTRUCTIONS. CURB RAMPS SHALL BE LOCATED OR PROTECTED TO PREVENT THEIR OBSTRUCTION BY MARKED VEHICLES.

4.7.9 LOCATION AT MARKED CROSSINGS. CURB RAMPS AT MARKED CROSSINGS SHALL BE WHOLLY CONTAINED WITHIN THE MARKINGS, EXCLUDING ANY FLARED SIDES.

4.7.10 DIAGONAL CURB RAMPS. IF DIAGONAL (OR CORNER TYPE) CURB RAMPS HAVE RETURNED CURBS OR OTHER WELL-DEFINED EDGES, SUCH EDGES SHALL BE PARALLEL TO THE DIAGONAL OF PEDESTRIAN FLOW. THE WIDTH OF DIAGONAL CURB RAMPS AT MARKED CROSSINGS SHALL BE 48" (1220 mm) CLEAR SPACE SHALL BE WITHIN THE MARKINGS. IF DIAGONAL CURB RAMPS HAVE FLARED SIDES, THE FLARED SIDES SHALL BE PARALLEL TO THE FLARED SEGMENT OF STRAIGHT CURB LOCATED ON EACH SIDE OF THE CURB RAMP AND WITHIN THE MARKED CROSSING.

4.7.11 ISLANDS. ANY RAISED ISLANDS IN CROSSING SHALL BE CUT THROUGH LEVEL WITH THE STREET OR HAVE CURB RAMPS AT BOTH SIDES AND A LEVEL AREA AT LEAST 48" (1220 mm) LONG IN THE PART OF THE ISLAND INTERSECTED BY THE CROSSING.

4.7.12 UNCURBED INTERSECTIONS. (REMOVED & RESERVED.)

4.8 RAMPS.

4.8.1 GENERAL. ANY PART OF AN ACCESSIBLE ROUTE WITH A SLOPE GREATER THAN 1:20 SHALL BE CONSIDERED A RAMP AND SHALL COMPLY WITH 4.8.

4.8.2 SLOPE & RISE. THE LEAST POSSIBLE SLOPE SHALL BE USED FOR ANY RAMP. THE MAXIMUM SLOPE OF A RAMP IN NEW CONSTRUCTION SHALL BE 1:12. THE MAXIMUM RISE FOR ANY RAMP SHALL BE 30" (762 mm). CURB RAMPS AND RAMPS TO BE CONSIDERED IN TABLES OR IN EXISTING BUILDINGS OR FACILITIES MAY HAVE SLOPES AND RISES AS SHOWN IN TABLE 2.

IF SPACE LIMITATIONS PROHIBIT THE USE OF A 1:12 SLOPE OR LESS (SEE 4.1.6).

4.8.3 CLEAR WIDTHS. THE MINIMUM CLEAR WIDTH OF A RAMP SHALL BE 36" (915 mm).

4.8.4 LANDINGS. RAMPS SHALL HAVE LEVEL LANDINGS AT THE BOTTOM AND TOP OF EACH RUN. LANDINGS SHALL HAVE THE FOLLOWING FEATURES:

- (1) THE LANDING SHALL BE AT LEAST AS WIDE AS THE RAMP RUN LEADING TO IT.
- (2) THE LANDING LENGTH SHALL BE A MINIMUM OF 60" (1525 mm) CLEAR.
- (3) IF RAMPS CHANGE DIRECTION AT LANDINGS, THE MINIMUM LANDING SIZE SHALL BE 60" BY 60" (1525 mm BY 1525 mm).
- (4) IF A DOORWAY IS LOCATED AT A LANDING, THEN THE AREA IN FRONT OF THE DOORWAY SHALL COMPLY WITH 4.13.6.

4.8.5 HANDRAILS. IF A RAMP RUN HAS A RISE GREATER THAN 6" (152 mm) OR A HORIZONTAL PROJECTION GREATER THAN 27" (686 mm), THEN IT SHALL HAVE HANDRAILS ON BOTH SIDES. HANDRAILS ARE NOT REQUIRED ON CURB RAMPS. HANDRAILS SHALL COMPLY WITH 4.8.6 AND SHALL HAVE THE FOLLOWING FEATURES:

- (1) HANDRAILS SHALL BE PROVIDED ALONG BOTH SIDES OF RAMP SEGMENTS. THE INSIDE HANDRAIL ON SWITCHBACK OR DOGLEG RAMPS SHALL ALWAYS BE CONTINUOUS.
- (2) IF HANDRAILS ARE NOT CONTINUOUS, THEY SHALL EXTEND AT LEAST 12" (305 mm) BEYOND THE TOP AND BOTTOM OF THE RAMP SEGMENT AND SHALL BE PARALLEL WITH THE FLOOR OR GROUND SURFACE.
- (3) THE CLEAR SPACE BETWEEN THE HANDRAIL AND THE WALL SHALL BE 1-1/2" (38 mm).
- (4) GRIPPING SURFACES SHALL BE CONTINUOUS.
- (5) TOP OF HANDRAIL GRIPPING SURFACES SHALL BE MOUNTED BETWEEN 34" & 34" (762 mm & 865 mm) ABOVE RAMP SURFACES.
- (6) ENDS OF HANDRAILS SHALL BE EITHER ROUNDED OR RETURNED SMOOTHLY TO FLOOR, WALL, OR POST.
- (7) HANDRAILS SHALL NOT ROTATE WITHIN THEIR FITTINGS.

4.8.6 CROSS SLOPE & SURFACES. THE CROSS SLOPE OF RAMP SURFACES SHALL BE NO GREATER THAN 1:50. RAMP SURFACES SHALL COMPLY WITH 4.5.

4.8.7 EDGE PROTECTION. RAMPS AND LANDINGS WITH DROP-OFFS SHALL HAVE CURBS, WALLS, BARRIERS, OR PROTECTING SURFACES THAT PREVENT PEOPLE FROM SLIPPING OFF THE RAMP. CURBS SHALL BE A MINIMUM OF 2" (50 mm) HIGH (SEE FIG. 17).

4.8.8 OUTDOOR CONDITIONS. OUTDOOR RAMPS AND THEIR APPROACHES SHALL BE DESIGNED SO THAT WATER WILL NOT ACCUMULATE ON WALKING SURFACES.

4.9 STAIRS.

4.9.1 MINIMUM NUMBER. STAIRS REQUIRED TO BE ACCESSIBLE BY 4.1 SHALL COMPLY WITH 4.9.

4.9.2 TREADS & RISERS. ON ANY GIVEN FLIGHT OF STAIRS, ALL STEPS SHALL HAVE UNIFORM RISE HEIGHTS AND UNIFORM TREAD WIDTHS. STAIR TREADS SHALL BE NO LESS THAN 11" (279 mm) WIDE, MEASURED FROM RISER TO RISER (SEE FIG. 15a). OPEN RISERS ARE NOT PERMITTED ON ACCESSIBLE ROUTES.

4.9.3 NOSINGS. THE UNDERSIDES OF NOSINGS SHALL NOT BE ABRUPT. THE RADIUS OF CURVATURE AT THE LEADING EDGE OF THE TREAD SHALL BE NO GREATER THAN 1/2" (13 mm). RISERS SHALL BE SLOPED OR THE UNDERSIDE OF THE NOSING SHALL HAVE AN ANGLE NOT LESS THAN 60 DEGREES FROM THE HORIZONTAL. NOSINGS SHALL PROJECT NO MORE THAN 1-1/2" (38 mm) (SEE FIG. 15).

4.9.4 HANDRAILS. STAIRWAYS SHALL HAVE HANDRAILS AT BOTH SIDES OF ALL STAIRS. HANDRAILS SHALL COMPLY WITH 4.8.6 AND SHALL HAVE THE FOLLOWING FEATURES:

- (1) HANDRAILS SHALL BE CONTINUOUS ALONG BOTH SIDES OF STAIRS. THE INSIDE HANDRAIL ON SWITCHBACK OR DOGLEG STAIRS SHALL ALWAYS BE CONTINUOUS (SEE FIG. 15a & 6).
- (2) IF HANDRAILS ARE NOT CONTINUOUS, THEY SHALL EXTEND AT LEAST 12" (305 mm) PLUS THE WIDTH OF ONE TREAD BEYOND THE BOTTOM RISER. AT THE TOP, THE EXTENSION SHALL BE PARALLEL WITH THE TOP OF THE TREAD. AT THE BOTTOM, THE HANDRAIL SHALL CONTINUE TO SUPPORT FOR A DISTANCE OF THE WIDTH OF ONE TREAD FROM THE BOTTOM RISER. THE REMAINDER OF THE EXTENSION SHALL BE HORIZONTAL (SEE FIG. 15a & 6).
- (3) THE CLEAR SPACE BETWEEN HANDRAILS AND WALLS SHALL BE 1-1/2" (38 mm).
- (4) GRIPPING SURFACES SHALL BE UNINTERRUPTED BY NEVEL POSTS, OTHER CONSTRUCTION ELEMENTS, OR OBSTRUCTIONS.
- (5) TOP OF HANDRAIL GRIPPING SURFACE SHALL BE MOUNTED BETWEEN 34" & 34" (762 mm & 865 mm) ABOVE STAIR NOSINGS.
- (6) ENDS OF HANDRAILS SHALL BE EITHER ROUNDED OR RETURNED SMOOTHLY TO FLOOR, WALL, OR POST.
- (7) HANDRAILS SHALL NOT ROTATE WITHIN THEIR FITTINGS.

4.9.5 TACTILE WARNINGS AT STAIRS. (REMOVED & RESERVED.)

4.9.6 OUTDOOR CONDITIONS. OUTDOOR STAIRS AND THEIR APPROACHES SHALL BE DESIGNED SO THAT WATER WILL NOT ACCUMULATE ON WALKING SURFACES.

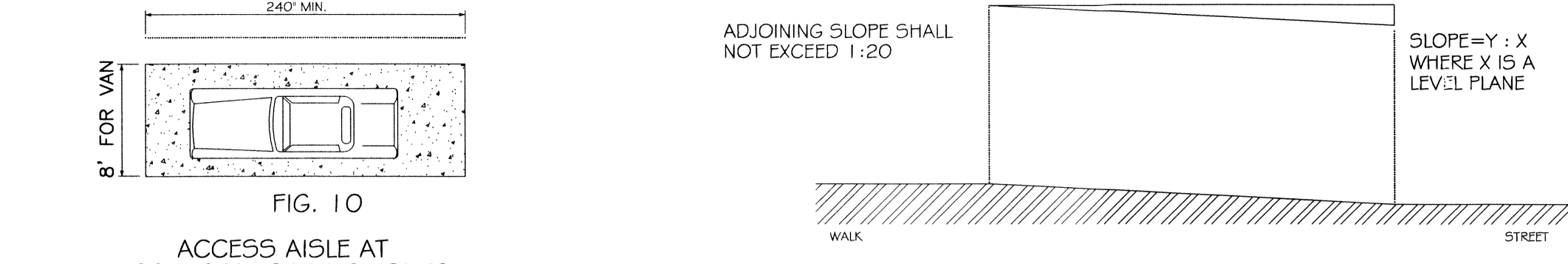

FIG. 11
MEASUREMENT OF CURB RAMP SLOPES
N.T.S.

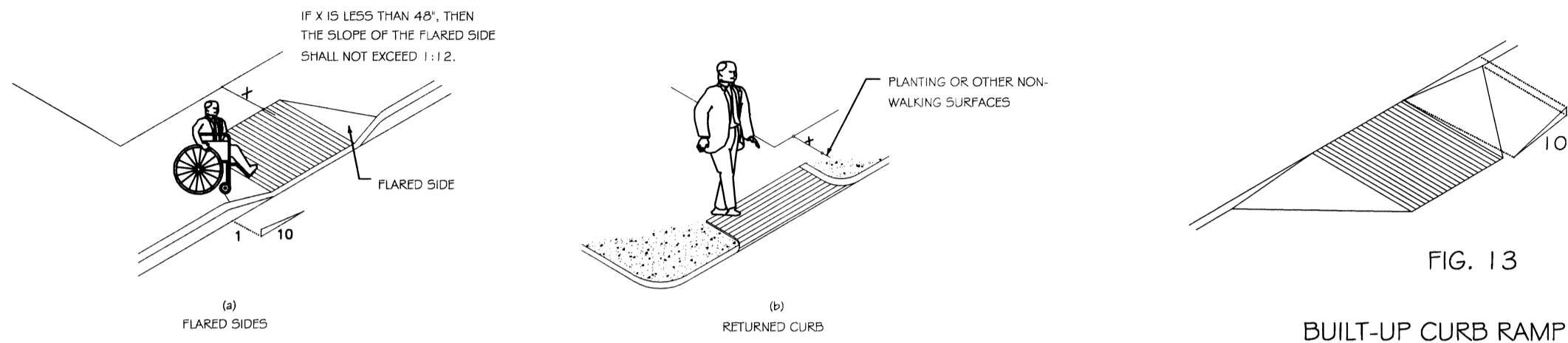

FIG. 13
BUILT-UP CURB RAMP
N.T.S.

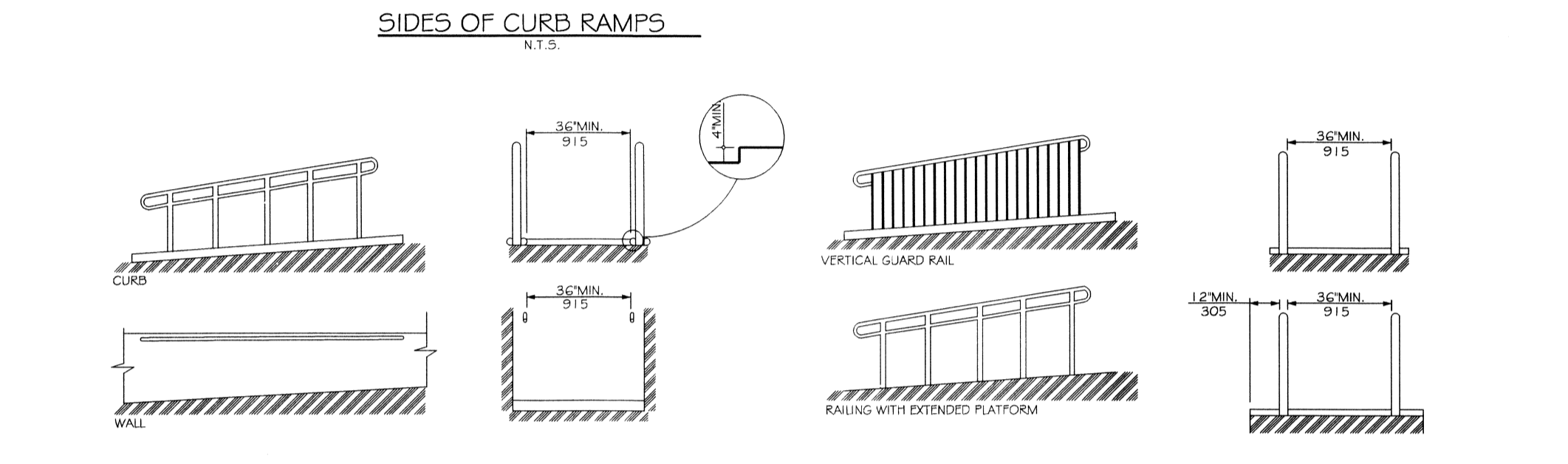

FIG. 17
EXAMPLES OF EDGE PROTECTION AND HANDRAIL EXTENSIONS
N.T.S.

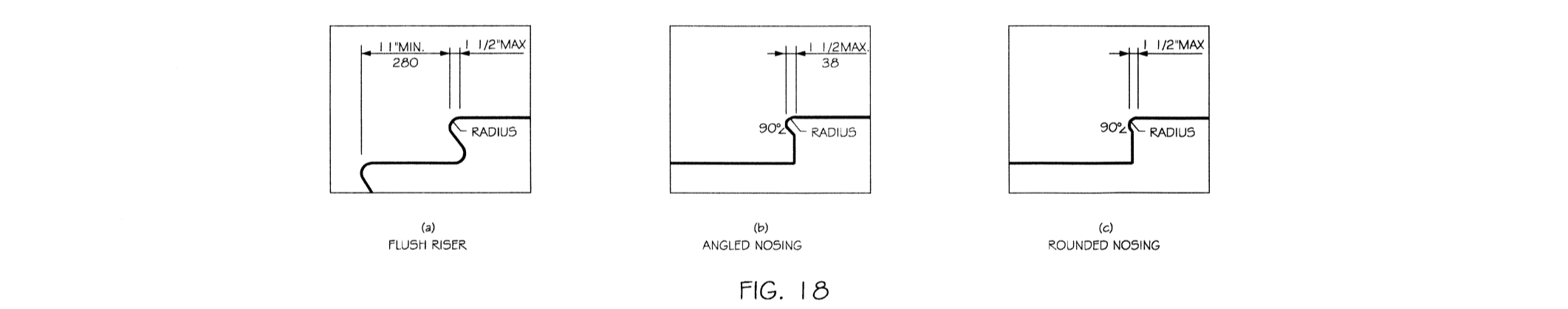

FIG. 18
USEABLE TREAD WIDTH AND EXAMPLES OF ACCEPTABLE NOSINGS
N.T.S.

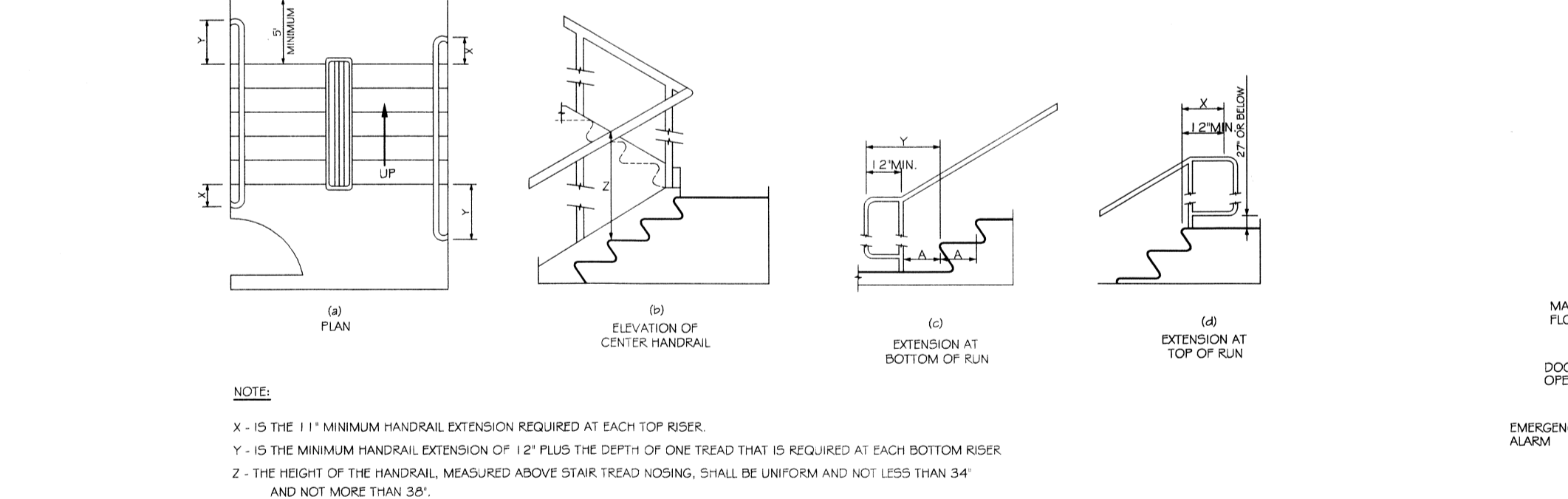

FIG. 19
STAIR HANDRAILS
N.T.S.

4.10 ELEVATORS.

4.10.1 GENERAL. ACCESSIBLE ELEVATORS SHALL BE ON AN ACCESSIBLE ROUTE AND SHALL COMPLY WITH 4.1 AND WITH THE ASME A17.1-1998 SAFETY CODE FOR ELEVATORS AND ESCALATORS. FREIGHT ELEVATORS SHALL NOT BE CONSIDERED AS MEETING THE REQUIREMENTS OF THIS SECTION UNLESS THE ONLY ELEVATORS PROVIDED ARE USED AS COMBINATION PASSENGER AND FREIGHT ELEVATORS FOR THE PUBLIC AND EMPLOYEES.

4.10.2 AUTOMATIC OPERATION. ELEVATOR OPERATION SHALL BE AUTOMATIC. EACH CAR SHALL BE EQUIPPED WITH A SELF-LEVELING FEATURE THAT WILL AUTOMATICALLY BRING THE CAR TO FLOOR LANDINGS WITHIN A TOLERANCE OF 1/2" (13 mm) UNDER RAISED LOADING. ZERO TO LOADING CONDITIONS. THIS SELF-LEVELING FEATURE SHALL BE AUTOMATIC AND INDEPENDENT OF THE OPERATING DEVICE AND SHALL CORRECT THE OVERTRAVEL OR UNDERTRAVEL.

4.10.3 HALL CALL BUTTONS. CALL BUTTONS IN ELEVATOR LOBBIES AND HALLS SHALL BE CENTERED AT 48" (1219 mm) ABOVE THE FLOOR. SUCH CALL BUTTONS SHALL HAVE VISUAL SIGNALS TO INDICATE WHEN EACH CALL IS REGISTERED AND WHEN EACH CALL IS ANSWERED. CALL BUTTONS SHALL BE A MINIMUM OF 3/4" (19 mm) IN THE SMALLEST DIMENSION. THE BUTTON DESIGNATING THE UP DIRECTION SHALL BE ON TOP. BUTTONS SHALL BE RAISED OR FLUSH. OBJECTS MOUNTED BENEATH HALL CALL BUTTONS SHALL NOT PROJECT INTO THE ELEVATOR LOBBY MORE THAN 4" (102 mm).

4.10.4 HALL LANTERNS. A VISIBLE AND AUDIBLE SIGNAL SHALL BE PROVIDED AT EACH POSTWAY ENTRANCE TO INDICATE WHICH CAR IS ANSWERING A CALL. AUDIBLE SIGNALS SHALL SOUND ONCE FOR THE UP DIRECTION AND TWICE FOR THE DOWN DIRECTION OR, SHALL HAVE VERBAL ANNUNCIATORS THAT SAY "UP" OR "DOWN". VISIBLE SIGNALS SHALL HAVE THE FOLLOWING FEATURES:

- (1) HALL LANTERNS SHALL BE MOUNTED SO THAT THEIR CENTERLINE IS AT LEAST 2 1/2" (64 mm) IN THE SMALLEST DIMENSION.
- (2) VISUAL ELEMENTS SHALL BE AT LEAST 2 1/2" (64 mm) IN THE SMALLEST DIMENSION.
- (3) SIGNALS SHALL BE VISIBLE FROM THE VICINITY OF THE HALL CALL BUTTON. IN CAR LANTERNS LOCATED IN CAR, VISIBILITY FROM THE VICINITY OF HALL CALL BUTTONS, AND CONFORMING TO THE ABOVE REQUIREMENTS, SHALL BE ACCEPTABLE.

FIG. 23
CAR CONTROLS
N.T.S.

4.10.5 RAISED & BRILLE CHARACTERS ON HOISTWAY ENTRANCES. ALL ELEVATOR HOISTWAY ENTRANCES SHALL HAVE RAISED AND BRILLE FLOOR DESIGNATIONS PROVIDED ON BOTH JAMBS. THE CENTERLINE OF THE CHARACTERS SHALL BE 60" (1525 mm) ABOVE FINISH FLOOR. SUCH CHARACTERS SHALL BE 2" (50 mm) HIGH AND SHALL COMPLY WITH 4.30.4. PERMANENTLY APPLIED PLATES ARE ACCEPTABLE IF THEY ARE PERMANENTLY FIXED TO THE JAMBS.

4.10.6 DOOR PROTECTIVE REOPENING DEVICE. ELEVATOR DOORS SHALL OPEN AND CLOSE AUTOMATICALLY. THEY SHALL BE PROVIDED WITH A REOPENING DEVICE THAT WILL STOP AND REOPEN A CAR DOOR AND HOISTWAY DOOR AUTOMATICALLY IF THE DOOR BECOMES OBSTRUCTED BY AN OBJECT OR PERSON. THE DEVICE SHALL BE CAPABLE OF COMPLETING THESE OPERATIONS WITHOUT REQUIRING CONTACT FOR AN OBSTRUCTION PASSING THROUGH THE OPENING AT HEIGHTS OF 5' 4" (1626 mm) & 7'35" (2238 mm) ABOVE FINISH FLOOR. DOOR REOPENING DEVICES SHALL REMAIN EFFECTIVE FOR AT LEAST 60 SECONDS. AFTER SUCH AN INTERVAL, DOORS MAY CLOSE IN ACCORDANCE WITH THE REQUIREMENTS OF ASME A17.1-1998.

4.10.7 DOOR SIGNAL TIMING FOR HALL CALLS. THE MINIMUM ACCEPTABLE TIME FROM NOTIFICATION THAT A CAR IS ANSWERING A CALL UNTIL THE DOORS OF THAT CAR START TO CLOSE SHALL BE CALCULATED FROM THE FOLLOWING EQUATION:

$$T = D / (1.5 / S) \text{ OR } T = D / (445 \text{ mm} / S)$$

WHERE T TOTAL TIME IN SECONDS AND D DISTANCE (IN FEET OR MILLIMETERS) FROM A POINT IN THE LOBBY OR CORRIDOR 60" (1525 mm) DIRECTLY IN FRONT OF THE FARTHEST CALL BUTTON CONTROLLING THAT CAR TO THE CENTERLINE OF ITS HOISTWAY DOOR. FOR CARS WITH IN-CAR LANTERNS, T BEGINS WHEN THE LANTERN IS VISIBLE FROM THE VICINITY OF HALL CALL BUTTONS AND AN AUDIBLE SIGNAL IS SOUNDING. THE MINIMUM ACCEPTABLE NOTIFICATION TIME SHALL BE 5 SECONDS.

4.10.8 DOOR DELAY FOR CAR CALLS. THE MINIMUM TIME FOR ELEVATOR DOORS TO REMAIN FULLY OPEN IN RESPONSE TO A CAR CALL SHALL BE 3 SECONDS.

4.10.9 FLOOR PLAN OF ELEVATOR CARS. THE FLOOR AREA OF ELEVATOR CARS SHALL PROVIDE SPACE FOR WHEELCHAIR USERS TO ENTER THE CAR, MANEUVER WITHIN REACH OF CONTROLS, AND EXIT FROM THE CAR. ACCEPTABLE DOOR OPENING AND NOISE DIMENSIONS SHALL BE AS SHOWN IN FIG. 22. THE CLEARANCE BETWEEN THE CAR PLATFORM SHIP AND THE EDGE OF ANY HOISTWAY LANDING SHALL BE NO GREATER THAN 1 1/4" (31 mm).

4.10.11 ILLUMINATION LEVELS. THE LEVEL OF ILLUMINATION AT THE CAR CONTROLS, PLATFORM, AND CAR THRESHOLD AND LANDING SHALL BE AT LEAST 5 FOOT-CANDELES (53.4 LUX).

4.10.12 CAR CONTROLS. ELEVATOR CONTROL PANELS SHALL HAVE THE FOLLOWING FEATURES:

- (1) BUTTONS. ALL CONTROL BUTTONS SHALL BE AT LEAST 3/4" (19 mm) IN THEIR SMALLEST DIMENSION. THEY SHALL BE RAISED OR FLUSH.
- (2) TACTILE, BRILLE, AND VISUAL CONTROL INDICATORS. ALL CONTROL BUTTONS SHALL BE DESIGNATED BY BRILLE AND BY RAISED STANDARD ALPHABET CHARACTERS FOR LETTERS, ARABIC CHARACTERS FOR NUMERALS, OR STANDARD SYMBOLS AS SHOWN IN FIG. 23a), AND AS REQUIRED IN ASME A17.1-1998. RAISED AND BRILLE CHARACTERS AND SYMBOLS SHALL COMPLY WITH 4.30. THE CALL BUTTON FOR THE MAIN ENTRY FLOOR SHALL BE DESIGNATED BY A RAISED SYMBOL. ALL RAISED CHARACTERS AND SYMBOLS SHALL BE AT LEAST 1/8" (3 mm) HIGH. ALL RAISED DESIGNATIONS FOR CONTROL BUTTONS SHALL BE PLACED IMMEDIATELY TO THE LEFT OF THE BUTTON TO WHICH THEY APPLY. APPROPRIATELY PERMANENTLY ATTACHED ARE AN ACCEPTABLE MEANS TO PROVIDE RAISED CONTROL DESIGNATIONS. FLOOR BUTTONS SHALL BE PROVIDED WITH VISUAL INDICATORS TO SHOW WHICH CALL IS ANSWERED. THE VISUAL INDICATORS SHALL BE EXTINGUISHED WHEN EACH CALL IS ANSWERED.
- (3) HEIGHT. ALL FLOOR BUTTONS SHALL BE NO HIGHER THAN 54" (1370 mm) ABOVE THE FINISH FLOOR FOR SIDE APPROACH AND 48" (1219 mm) FOR FRONT APPROACH. EMERGENCY CONTROLS, INCLUDING THE EMERGENCY ALARM AND EMERGENCY STOP, SHALL BE GROUPED AT THE BOTTOM OF THE PANEL AND SHALL HAVE THEIR CENTERLINE NO LESS THAN 35" (890 mm) ABOVE THE FINISH FLOOR (SEE FIG. 23a & 9).

4.10.13 CAR POSITION INDICATORS. IN ELEVATOR CARS, A VISUAL CAR POSITION INDICATOR SHALL BE PROVIDED ABOVE THE CAR CONTROL PANEL OR OVER THE DOOR TO SHOW THE LOCATION OF THE ELEVATOR IN THE HOISTWAY. AS THE CAR PASSES OR STOPS AT A FLOOR SERVED BY THE ELEVATORS, THE CORRESPONDING NUMERALS SHALL ILLUMINATE, AND AN AUDIBLE SIGNAL SHALL SOUND. NUMERALS SHALL BE A MINIMUM OF 1/2" (13 mm) HIGH. THE AUDIBLE SIGNAL SHALL BE NO LESS THAN 50 DECIBELS WITH A FREQUENCY NO HIGHER THAN 1500HZ. THE FLOOR NUMBER AT WHICH A CAR STOPS OR WHICH A CAR PASSES MAY BE SUBSTITUTED FOR AN AUTOMATIC VERBAL ANNOUNCEMENT THE AUDIBLE SIGNAL.

4.10.14 EMERGENCY COMMUNICATIONS. IF PROVIDED, EMERGENCY TWO-WAY COMMUNICATION SYSTEMS BETWEEN THE ELEVATOR AND A POINT OUTSIDE THE HOISTWAY SHALL COMPLY WITH ASME A17.1-1998. THE HIGHEST OPERABLE PART OF A TWO-WAY COMMUNICATION SYSTEM SHALL BE A MINIMUM OF 48" (1219 mm) FROM THE FLOOR OF THE CAR. IT SHALL BE IDENTIFIED BY A RAISED SYMBOL AND LETTERING COMPLYING WITH 4.30 AND LOCATED ADJACENT TO THE DEVICE. IF THE SYSTEM USES HANDSET THEN THE LENGTH OF THE CORD FROM THE PANEL TO THE HANDSET SHALL BE AT LEAST 29" (735 mm). IF THE SYSTEM IS LOCATED IN A CLOSED COMPARTMENT, THE COMPARTMENT DOOR HARDWARE SHALL CONFORM TO 4.27. CONTROLS AND OPERATING MECHANISMS. THE EMERGENCY INTERCOMUNICATION SYSTEM SHALL NOT REQUIRE VOICE COMMUNICATION.

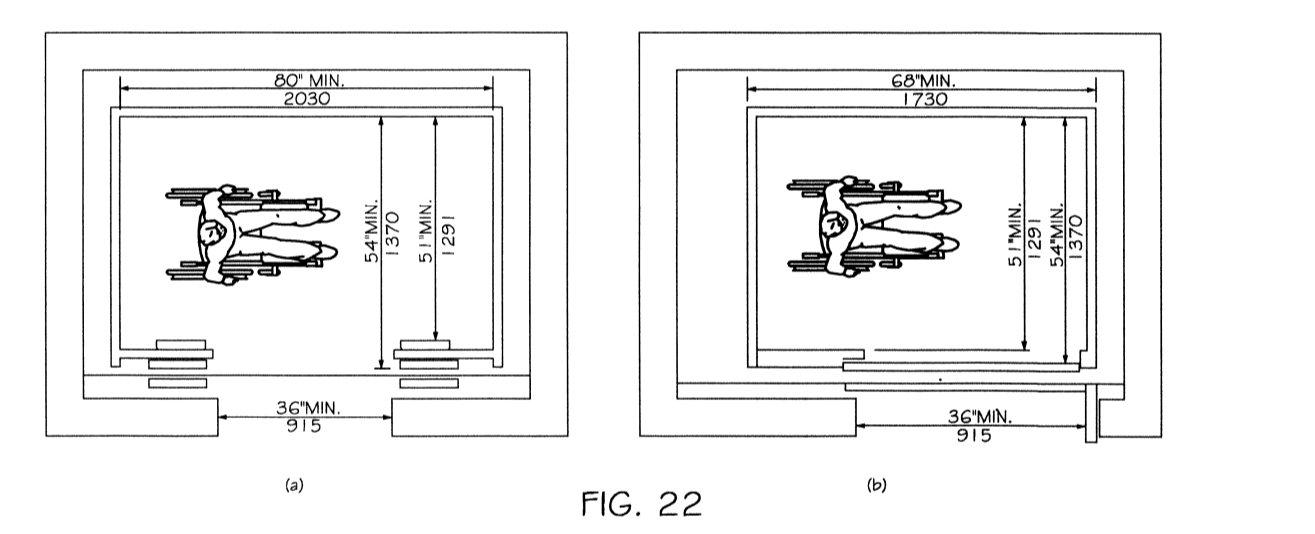

FIG. 22
MINIMUM DIMENSION OF ELEVATOR CARS
N.T.S.

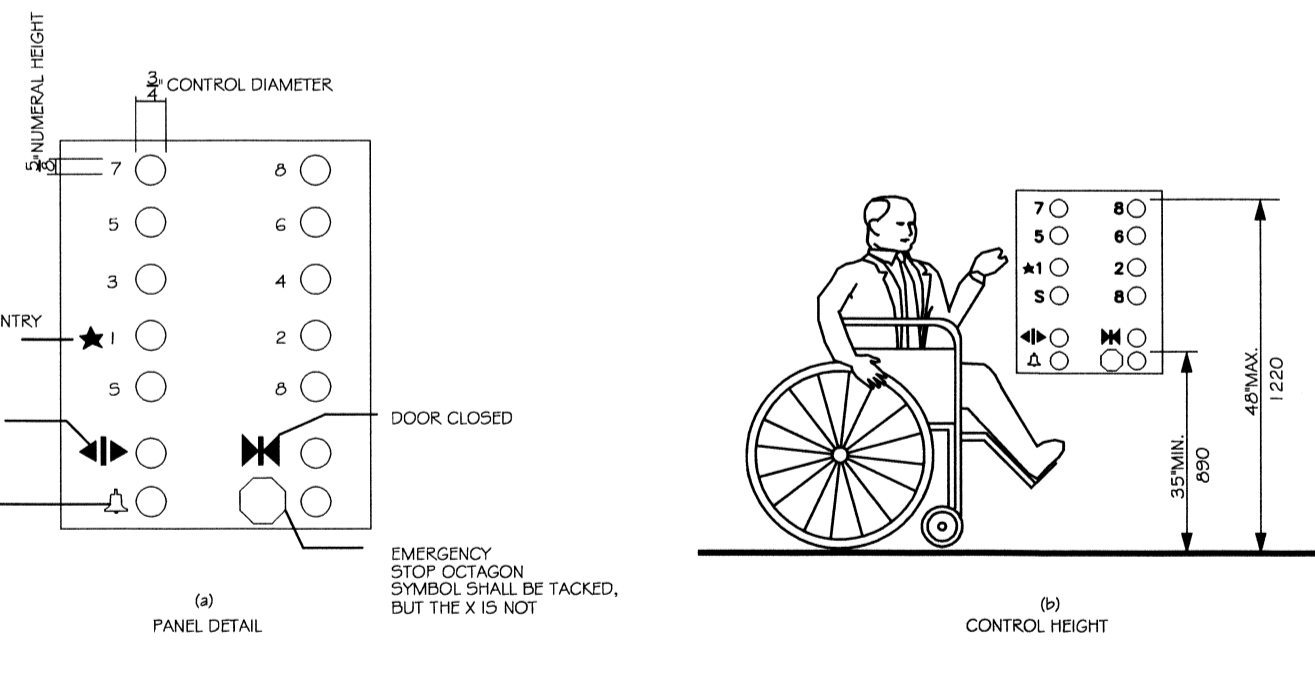

FIG. 23
CAR CONTROLS
N.T.S.

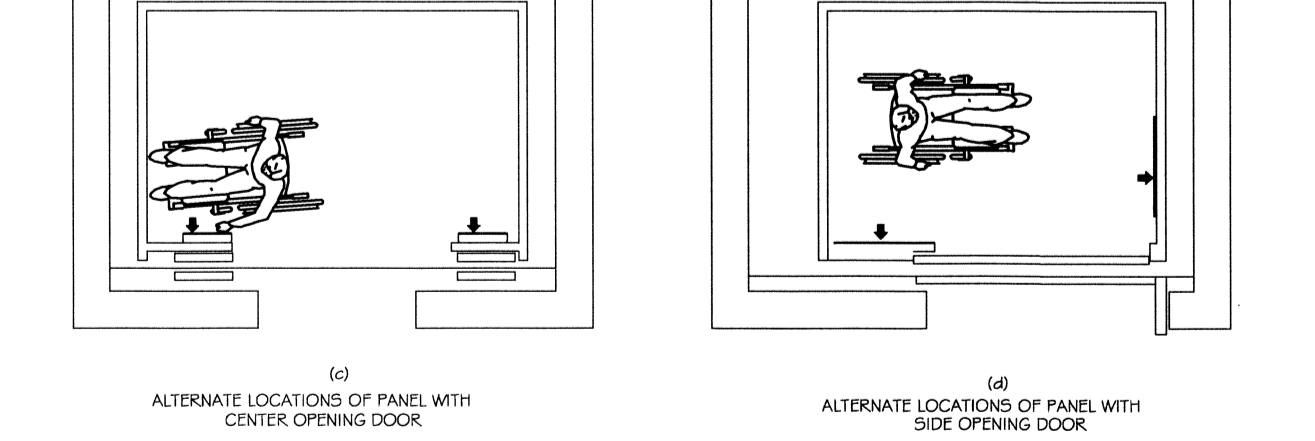

FIG. 23
CAR CONTROLS
N.T.S.

4.11 PLATFORM LIFTS (WHEELCHAIR LIFTS).

4.11.1 LOCATION. PLATFORM LIFTS (WHEELCHAIR LIFTS) PERMITTED BY 4.1 SHALL COMPLY WITH THE REQUIREMENTS OF 4.1.1.

4.11.2 OTHER REQUIREMENTS. IF PLATFORM LIFTS (WHEELCHAIR LIFTS) ARE USED, THEY SHALL COMPLY WITH 4.2.4, 4.5, 4.27, & ASME A17.1 SAFETY CODE FOR ELEVATORS AND ESCALATORS, SECTION IX, 1998.

4.11.3 ENTRANCE. IF PLATFORM LIFTS ARE USED THEN THEY SHALL FACILITATE UNASSISTED ENTRY, OPERATION, AND EXIT FROM THE LIFT IN COMPLIANCE WITH 4.1.1.2.

4.12 WINDOWS.

4.12.1 GENERAL. (RESERVED.)

4.12.2 WINDOW HARDWARE. (RESERVED.)

4.13 DOORS.

4.13.1 GENERAL. DOORS REQUIRED TO BE ACCESSIBLE BY 4.1 SHALL COMPLY WITH THE REQUIREMENTS OF 4.1.5.

4.13.2 REVOLVING DOORS & TURNSTILES. REVOLVING DOORS OR TURNSTILES SHALL NOT BE THE ONLY MEANS OF PASSAGE AT AN ACCESSIBLE ENTRANCE OR ALONG AN ACCESSIBLE ROUTE. AN ACCESSIBLE GATE OR DOOR SHALL BE PROVIDED ADJACENT TO THE TURNSTILE OR REVOLVING DOOR AND SHALL BE SO DESIGNATED AS TO FACILITATE THE SAME USE PATTERN.

4.13.3 GATES. GATES, INCLUDING TICKET GATES, SHALL MEET ALL APPLICABLE SPECIFICATIONS OF 4.1.3.

4.13.4 DOUBLE-LEAF DOORWAYS. IF DOORWAYS HAVE TWO INDEPENDENTLY OPERATED LEAF LEAVES, THEN AT LEAST ONE LEAF SHALL MEET THE SPECIFICATIONS IN 4.13.5.4.1.3.6. THAT LEAF SHALL BE AN ACTIVE LEAF.

4.13.5 CLEAR WIDTH. DOORWAYS SHALL HAVE A MINIMUM CLEAR OPENING OF 32" (813 mm) WITH THE DOOR OPEN 90 DEGREES, MEASURED BETWEEN THE FACE OF THE DOOR AND THE OPPOSITE STOP. OPENINGS MORE THAN 24" (610 mm) DEPTH SHALL COMPLY WITH 4.2.1.4.4.3.5. EXCEPTION: DOORS NOT REQUIRING FULL LOCK PASSAGE, SUCH AS SHALLOW CLOSETS, MAY HAVE THE CLEAR OPENING REDUCED TO 27" (686 mm) MINIMUM.

4.13.6 MANEUVERING CLEARANCES AT DOORS. THE FLOOR OR GROUND AREA WITHIN THE REQUIRED CLEARANCES SHALL BE LEVEL AND CLEAR.

EXCEPTION: ENTRY DOORS TO ADULT CARE HOSPITAL BEDROOMS FOR IN-PATIENTS SHALL BE EXEMPT FROM THE REQUIREMENT FOR SPACE AT THE LEADING SIDE OF THE DOOR IF THE DOOR IS AT LEAST 44" (1118 mm) WIDE.

4.13.7 TWO DOORS IN SERIES. THE MINIMUM SPACE BETWEEN TWO HINGED OR PIVOTED DOORS IN SERIES SHALL BE 48" (1219 mm) PLUS THE WIDTH OF ANY DOOR SWINGING INTO THE SPACE. DOORS IN SERIES SHALL SWING EITHER IN THE SAME DIRECTION OR AWAY FROM THE SPACE BETWEEN THE DOORS.

4.13.8 THRESHOLDS AT DOORWAYS. THRESHOLDS AT DOORWAYS SHALL NOT EXCEED 3/4" (19 mm) IN HEIGHT FOR EXTERIOR SLIDING DOORS OR 1/2" (13 mm) FOR OTHER TYPES OF DOORS. RAISED THRESHOLDS AND FLOOR LEVEL CHANGES AT ACCESSIBLE DOORWAYS SHALL BE BEVELLED WITH A SLOPE NO GREATER THAN 1:2 (SEE 4.5.2).

4.13.9 DOOR HARDWARE. HANDLES, LATCHES, LOCKS, AND OTHER OPERATING DEVICES ON ACCESSIBLE DOORS SHALL HAVE A SHAPE THAT IS EASY TO GRASP WITH ONE HAND AND DOES NOT REQUIRE TIGHT GRASPING, FIGHT PUNCHING, OR TWISTING OF THE WRIST TO OPERATE. LEVER OPERATED MECHANISMS, PUSH TYPE MECHANISMS, AND SHAPED HANDLES ARE ACCEPTABLE DESIGNS. WHEN SLIDING DOORS ARE FULLY OPEN, OPERATING HARDWARE SHALL BE OPENED AND USABLE FROM BOTH SIDES. HARDWARE REQUIRED FOR ACCESSIBLE DOOR PASSAGE SHALL BE MOUNTED HIGHER THAN 48" (1219 mm) ABOVE FINISHED FLOOR.

4.13.10 DOOR CLOSERS. IF A DOOR HAS A CLOSER, THEN THE SWEEP PERIODIC OF THE CLOSER SHALL BE ADJUSTED SO THAT FROM AN OPEN POSITION OF 70 DEGREES, THE DOOR WILL TAKE AT LEAST 3 SECONDS TO MOVE TO A POINT 3" (76 mm) FROM THE LATCH, MEASURED TO THE LEADING EDGE OF THE DOOR.

4.13.11 DOOR OPENING FORCE. THE MAXIMUM FORCE FOR PUSHING OR PULLING OPEN A DOOR SHALL BE AS FOLLOWS:

- (1) FIRE DOORS SHALL HAVE THE MINIMUM OPENING FORCE ALLOWABLE BY THE APPROPRIATE ADMINISTRATIVE AUTHORITY.
- (2) OTHER DOORS.
 - (a) EXTERIOR HINGED DOORS: (RESERVED.)
 - (b) INTERIOR HINGED DOORS: 5 LBF (22.2 N)
 - (c) SLIDING OR FOLDING DOORS: 5 LBF (22.2 N)

THESE FORCES DO NOT APPLY TO THE FORCE REQUIRED TO RETRACT LATCH BOLTS OR DISengage OTHER DEVICES THAT MAY HOLD THE DOOR IN A CLOSED POSITION.

4.13.12 AUTOMATIC DOORS AND POWER-ASSISTED DOORS. IF AN AUTOMATIC DOOR IS USED, THEN IT SHALL COMPLY WITH ANSI A156.10-1995 SLOWLY OPERATING LOW-POWERED AUTOMATIC DOORS SHALL COMPLY WITH ANSI A156.19-1994. SUCH DOORS SHALL NOT OPEN TO BACK CHECK. AFTER SUCH DOORS ARE FULLY OPEN, OPERATING HARDWARE SHALL BE OPENED AND USABLE FROM BOTH SIDES. IF A POWER-ASSISTED DOOR IS USED, ITS DOOR-OPENING FORCE SHALL COMPLY WITH 4.13.11 AND ITS CLOSING SHALL CONFORM TO THE REQUIREMENTS IN ANSI A156.19-1994.

4.14 ENTRANCES.

4.14.1 MINIMUM NUMBER. ENTRANCES REQUIRED TO BE ACCESSIBLE BY 4.1 SHALL BE PART OF AN ACCESSIBLE ROUTE COMPLYING WITH 4.3. SUCH ENTRANCES SHALL BE CONNECTED BY AN ACCESSIBLE ROUTE TO PUBLIC TRANSPORTATION STOPS, TO ACCESSIBLE PARKING AND PASSENGER LOADING ZONES, AND TO PUBLIC STREETS OR SIDEWALKS (IF AVAILABLE (SEE 4.3.2.1)). THEY SHALL ALSO BE CONNECTED BY AN ACCESSIBLE ROUTE TO ALL ACCESSIBLE SPACES OR ELEMENTS WITHIN THE BUILDING OR FACILITY.

4.14.2 SERVICE ENTRANCES. A SERVICE ENTRANCE SHALL NOT BE THE SOLE ACCESSIBLE ENTRANCE UNLESS IT IS THE ONLY ENTRANCE TO A BUILDING OR FACILITY (FOR EXAMPLE, IN A FACTORY OR GARAGE).

4.15 DRINKING FOUNTAINS AND WATER COOLERS.

4.15.1 MINIMUM NUMBER. DRINKING FOUNTAINS OR WATER COOLERS REQUIRED TO BE ACCESSIBLE BY 4.1 SHALL COMPLY WITH 4.1.5.

4.15.2 SPOUT HEIGHT. SPOUTS SHALL BE NO HIGHER THAN 36" (915 mm), MEASURED FROM THE FLOOR OR GROUND SURFACES TO THE SPOUT OUTLET.

4.15.3 SPOUT LOCATION. THE SPOUTS OF DRINKING FOUNTAINS AND WATER COOLERS SHALL BE AT THE FRONT OF THE UNIT AND SHALL DIRECT THE WATER FLOW IN A TRAJECTORY THAT IS PARALLEL OR NEARLY PARALLEL TO THE FRONT OF THE UNIT. THE SPOUT SHALL PROVIDE A FLOW OF WATER AT LEAST 4" (102 mm) HIGH SO AS TO ALLOW THE INSERTION OF A CUP OR GLASS UNDER THE FLOW OF WATER ON AN ACCESSIBLE DRINKING FOUNTAIN WITH A ROUND OR OVAL BOWL. THE SPOUT MUST BE POSITIONED SO THE FLOW OF WATER IS WITHIN 3" (75 mm) OF THE FRONT EDGE OF THE FOUNTAIN.

4.15.4 CONTROLS. CONTROLS SHALL COMPLY WITH 4.27.4. UNIT CONTROLS SHALL BE FRONT MOUNTED OR SIDE MOUNTED NEAR THE FRONT EDGE.

4.15.5 CLEARANCES.

- (1) WALL- AND POST-MOUNTED CANTILEVERED UNITS SHALL HAVE A CLEAR KNEE SPACE BETWEEN THE BOTTOM OF THE APRON AND THE FLOOR OR GROUND AT LEAST 27" (686 mm) HIGH, 30" (762 mm) WIDE, AND 17" TO 19" (430 mm TO 483 mm) DEEP. SUCH UNITS SHALL ALSO HAVE A MINIMUM CLEAR FLOOR SPACE 30" BY 48" (762 mm BY 1219 mm) TO ALLOW A PERSON IN A WHEELCHAIR TO APPROACH THE UNIT FACING FORWARD.
- (2) FREE-STANDING OR BUILT-IN UNITS NOT HAVING A CLEAR SPACE UNDER THEM SHALL HAVE A CLEAR FLOOR SPACE AT LEAST 30" BY 48" (762 mm BY 1219 mm) THAT ALLOWS A PERSON IN A WHEELCHAIR TO MAKE A PARALLEL APPROACH TO THE UNIT. THIS CLEAR FLOOR SPACE SHALL ALSO HAVE A MINIMUM CLEAR FLOOR SPACE 30"