

DAMMON
ENGINEERING, INC.

CHIEF ENGINEER
EMMETT
DAMMON, P.E.
CHIEF ARCHITECT
ROBERT
WILTSE

554 OLD SPANISH TRAIL
SLIDELL, LA, 70458
OFFICE: 985-649-5832
FAX: 985-641-5950

WEBSITE:
WWW.DAMMONENGINEERING.COM
EMAIL:
DAMMONENG@BELLCSOUTH.NET

ARCHITECTURE
ENGINEERING
STUDIES
PLANNING
INVESTIGATION
EXPERT WITNESS

LIVING THE WORD
INTERNATIONAL

25228
OLD SPANISH TRAIL
SLIDELL, LA
70461

SITE
PLAN

REV:

SCALE: AS NOTED

JOB#: 2128

DATE: 01-27-12

SHEET 2

A-1

OF 15

- SITE LEGEND**
- - - PROPERTY LINE
 - - - SETBACK LINE
 - - - BUFFER ZONE LINE
 - - - UTIL. EASEMENT LINE
 - - - OPAQUE BUFFER FENCE
 - ⊕ HANDICAP PARKING
 - ⊕ HANDICAP PARKING SIGN
 - ⊕ LITTER RECEPTACLE
 - ⇨ TRAFFIC ARROW

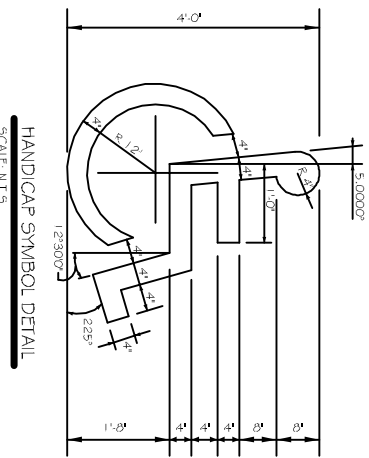

NOTE:
SPACE SHALL COMPLY
WITH SIGNAGE GUIDELINES

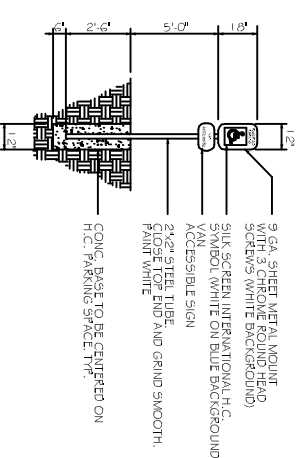

HCP RAMP NOTE:
PROVIDE DETECTABLE WARNING ON RAMP, CUT X
DEEP GROOVES @ 2-3\"/>

PARKING REQUIREMENTS
1.8,200 s.f. TOTAL BLDG. AREA, 534 OCCUPANTS
REQUIRES: 1 SPACE / 4 OCCUPANTS
TOTAL PARKING REQUIRED = 133.5 (6 HCP)
TOTAL PARKING PROVIDED = 147 SPACES (6 HCP)

SITE LIGHTING
EXTERIOR LIGHTING SHALL BE SHADED OR INWARDLY
DIRECTED IN SUCH A MANNER SO THAT NO DIRECT
LIGHTING OR GLARE BE CAST BEYOND THE PROPERTY
LINE. THE INTENSITY OF SUCH LIGHTING SHALL NOT
EXCEED ONE FOOT CANDLE AS MEASURED AT THE
ABUTTING PROPERTY LINE. (N/A)

SITE PLAN NOTES

1. ROOFING MATERIAL: METAL SSR
2. SIDING MATERIAL: STUCCO FRONT
METAL SIDING ON SIDES AND REAR
3. UTILITIES: ALL UTILITIES SHALL BE PLACED
UNDERGROUND.

