



October 18, 2024

Re: 1st Baptist Church Restroom Bldg Wall Strength

Assumptions :

Grade 60 rebar has a yield strength of 60,000 psi

Density of concrete = 150 #/ft³

Density of water (ρ)= 62.4 #/ft³

Calculate the pressure from water at depth.

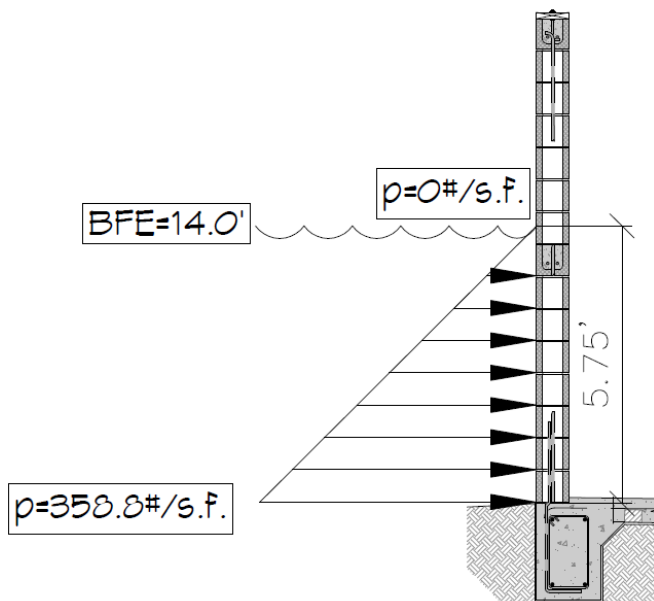

The pressure from the water at the top is nothing increasing to 62.4 pcf x 5.75 ft = 358.8 psf

To get an equivalent uniform distributed load 358.8 psf x 1.03 = 369.6 psf

To get a total pressure along the wall 369.6 psf x 5.75 ft = 2,125.2 plf

Then multiply by the length of each wall 16.25 lf x 2,125.2 plf for a total pressure against the wall of 34,534.5 #

A #5 vertical rebar has been imbedded in concrete foundation @ 24 inches on center and extended up to the top of the CMU wall. Each rebar has a yield strength of 60,000 psi. The rebar will keep the structure from collapsing.

David Dammon