

# XP/XA 2' x 4' Lens Recessed Fluorescent **XP/XA432**

## Features

- Efficiency 83.0%.
- Shallow 3" deep housing.
- Ribbed housing for strength and stability.
- Ends of housing formed inward for safe handling.
- Built-in earthquake clips.
- Hemmed-over side rails for safe handling.
- Ends have screw dimples for installation to T-bar (no fixture or ceiling distortion).
- Flat steel or regressed aluminum lens frame with mitered corners.
- Edges of steel door frame hemmed-over for safe handling.
- No light leak.
- Internal "T" hinges – easy installation and maintenance.
- Rooster head spring latches.
- Meets code 30 requirements in New England.



## Mounting Methods

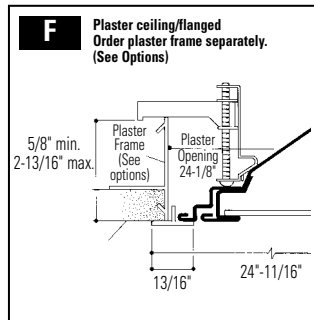
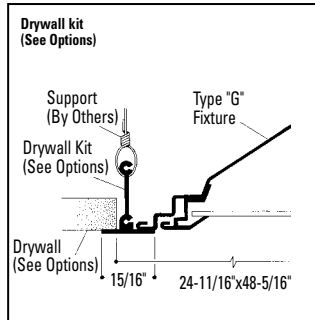
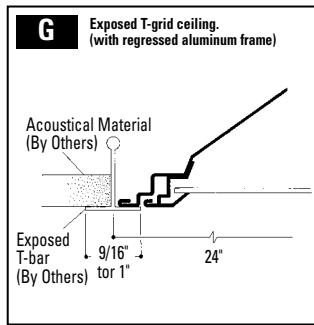
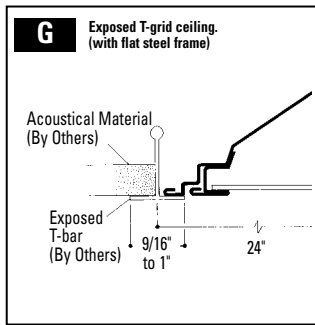

## Dimensions

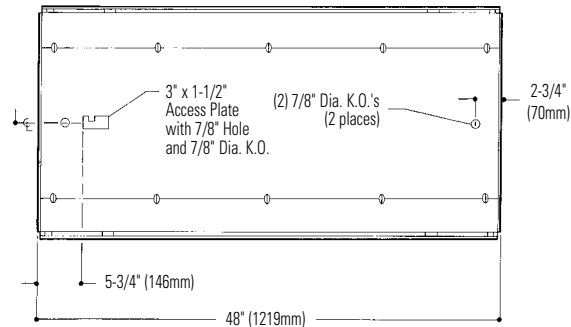
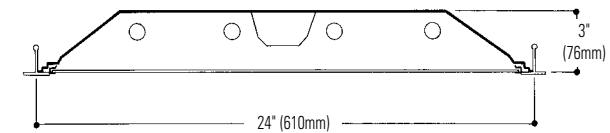

## Job Information

Type:

Job Name:

Cat. No.:

Lamp(s):

Volts/Ballast:

Lightolier a Genlyte Thomas Company

www.lightolier.com

Technical Information: (978) 657-7600 • Fax (978) 658-0595

631 Airport Road, Fall River, MA 02720 • (508) 679-8131 • Fax (508) 674-4710

We reserve the right to change details of design, materials and finish.

© 2002 Genlyte Thomas Group LLC (Lightolier Division) A0303

Section 1A/Folio F70-12

**LIGHTOLIER**®

# XP/XA 2' x 4' Lens Recessed Fluorescent **XP/XA432**

## Photometry

Model No. **XP2GVA43212004**

G TESTING LABORATORY

45 Industrial Way  
Wilmington, MA 01887  
(978) 657-7600

---

REPORT NO.: G22910      DATE: 7/2/02  
 CATALOG NO.: XP2GVA43212004  
 LAMP(S): 4 F32T8, EACH RATED 2850 LUMENS  
 LUMINAIRE: 2X4 G TROFFEN w/ VA LENS TRIAD B432112GRK-A

**CANDELA DISTRIBUTION**

0	0	22.5	45	67.5	90	0
0	3551	3551	3551	3551	3551	3551
5	3559	3554	3546	3535	3527	338
15	3433	3441	3475	3497	3505	981
25	3158	3195	3259	3321	3410	1517
35	2735	2801	2963	3101	3154	1844
45	2140	2210	2364	2507	2568	1815
55	1426	1496	1630	1678	1719	1429
65	819	844	835	888	945	863
75	487	463	371	428	472	468
85	204	205	178	176	193	201
90	29	35	38	40	39	

**ZONAL LUMEN SUMMARY**

ZONE	LUMENS	%LAMP	%FIXT
0-30	2836	25.0	30.0
0-40	4679	41.0	50.0
0-60	7923	70.0	84.0
0-90	9454	83.0	100.0
90-180	0	0.0	100.0
0-180	9454	83.0	100.0

**TOTAL LUMINAIRE EFFICIENCY = 83.0%**  
 CIR TYPE - DIRECT

FLARE: 0-DEG 90-DEG  
 SPACING CRITERIA: 1.2 1.4  
 SHIELDING ANGLES: 90 90  
 FLARE: 0-DEG 90-DEG  
 LUMINOUS LENGTH: 146.000 21.000

**LUMINANCE DATA IN CANDELA/SQ M**  
 ANGLE AVERAGE AVERAGE AVERAGE  
 IN DEG 0-DEG 45-DEG 90-DEG  
 45 4854 5362 5825  
 55 3988 4558 4804  
 65 3108 3169 3587  
 75 3018 2299 2925  
 85 3754 3276 3497



THIS REPORT IS BASED ON PUBLISHED INDUSTRY PROCEDURES • FIELD PERFORMANCE MAY VARY FROM LABORATORY PERFORMANCE.

LER = FL - 74.3 IW - 112 BF - 0.88  
 Comparative yearly lighting energy cost per 1000 lumens = \$3.23

### coefficients of utilization — zonal cavity method (effective floor cavity reflectance 0.20)

RF	20			20			20		
	RC	80	50	RC	80	50	RC	80	50
RW	70	50	30	50	30	10	50	30	10
1	91	87	84	82	79	77	78	76	74
2	83	76	71	72	68	64	69	66	63
3	76	68	61	64	59	55	62	57	54
4	70	60	53	57	51	47	55	50	46
5	64	54	47	51	45	41	50	45	40
6	60	49	42	47	41	36	45	40	36
7	55	44	37	42	36	32	41	36	32
8	52	41	34	39	33	29	38	32	28
9	48	37	31	36	30	26	35	30	26
10	45	34	28	33	27	23	32	27	23

### visual comfort probability (rated lumens per lamp 2850.)

room size	ceiling height				ceiling height					
	W	L	8.5	10.0	13.0	16.0	8.5	10.0	13.0	16.0
20	20	30	54	59	67	76	53	57	63	72
20	30	40	46	51	57	64	47	50	54	61
20	40	60	41	45	51	57	43	46	49	53
20	60	80	37	41	45	51	39	42	45	49
30	20	30	56	60	65	73	55	59	63	71
30	30	40	47	51	55	62	48	51	54	59
30	40	60	42	45	49	54	43	46	49	52
30	60	80	37	41	43	48	39	42	44	47
30	80	100	35	38	40	44	37	40	41	44
40	20	30	58	62	67	72	57	61	65	71
40	30	40	49	53	56	61	49	53	55	59
40	40	60	43	46	50	53	45	47	49	52
40	60	80	38	41	43	47	40	43	44	47
40	80	100	35	38	39	43	38	40	41	44
40	100	100	34	36	37	40	37	39	39	42
60	30	40	50	54	57	62	50	54	56	60
60	40	60	44	48	50	54	45	48	50	53
60	60	80	39	42	43	47	41	43	44	47
60	80	100	35	38	39	43	38	40	41	44
60	100	100	34	36	37	40	36	38	39	41
100	40	60	47	50	53	57	48	51	52	55
100	60	80	42	44	46	49	43	45	46	49
100	80	100	38	40	41	44	40	42	43	45
100	100	100	36	37	38	41	38	40	40	41

## Ordering Information

Explanation of Catalog Number. Example: XP2GVA232120SGLR

<b>XP</b>	<b>2</b>	<b>VA</b>	<b>4</b>	<b>32</b>	<b>120 or 277</b>	<b>Options:</b> Add appropriate suffix to catalog no, ie: (GLR)
Recessed Fluorescent with Flat Steel Lens Frame	Fixture Width	Ceiling Type: G = Grid (lay-in) T-bar F = Flanged (overlap) Z spline and plaster frame	Lamp Quantity: (By others) 4 = 4-Lamp	Lamp Fixture Length: 32-T8, 4' Length	Voltage: 120 or 277	Ballast: 2-2 Lamp Elec. (T8)    <20THD 1-4 Lamp Elec. (T8)    SO*    HI* LOL Dimming (T8)    O4*    H4* PS *Instant Start Standard Other dimming options. Consult factory.
XA = Recessed Fluorescent with Regressed Aluminum Lens Frame		Lens Shielding Type: VA = Virgin Acrylic (standard) see options and consult factory				

## Options/Accessories

**Special Lens:** Substitute VI for .125" nominal pattern. For other lenses, consult factory.

**Access Plates:** Top wiring access plate is shipped with fixture as standard. When access plates are required in advance for wiring convenience, specify separately. Order Catalog number: **ACPX CSP**.

**Electrical Wiring Options:** Consult factory.

**Fusing:** Internal fast-blow fusing. Suffix: **GLR**.

Internal slow-blow fusing. Suffix: **GMF**.

**Radio Interference Filter:** 120 or 277 volt, 50 or 60 Hz. One per fixture: Suffix: **R**. One per ballast: Suffix: **B**.

**Drywall Kit:** Order Catalog Number: **FK92x4** (Request Folio OA30-10).

## Specifications

**Performance:** In an installation of 4 lamps 32 W luminaires in a room cavity of 1, with reflectance of 80% ceiling, 50% walls, 20% floor, the C.U. shall not be less than .87. To control veiling reflections, luminaire output in the 30°-90° zone shall be not less than 70%.

**Materials: Chassis parts** are die-formed code gauge cold rolled steel.

**Housing** is embossed for added strength and rigidity with all edges turned over for safe handling. **Lens frames**—(XP) flat full-size steel frame, (XA) regressed full-size aluminum frame.

**Finish: Chassis exterior**—white baked polyester enamel. **Cavity**—white baked polyester enamel minimum 86% reflectance. Phosphate undercoating.

## Specifications (continued)

**Lens:** Extruded virgin acrylic 3/16" square based female cones, running 45° to the panel edge. .095" nominal thickness (similar to pattern 12).

**Electrical:** Thermally protected class "P" ballast C.B.M. approved, non PCB. If K.O. is within 3" of ballast, use wire suitable for at least 90°.

**Labels:** I.B.E.W./UL and ULc Listed.

## Job Information

Type:

**Lightolier** a Genlyte Thomas Company www.lightolier.com  
 Technical Information: (978) 657-7600 • Fax (978) 658-0595  
 631 Airport Road, Fall River, MA 02720 • (508) 679-8131 • Fax (508) 674-4710  
 We reserve the right to change details of design, materials and finish.  
 © 2002 Genlyte Thomas Group LLC (Lightolier Division) A0303