

Alonzo

* Enclosed parking

~~2400 Jeff~~

~~Slide~~ Slide gate

Need zoning requirements

Robert Johnston

504-736-6335

Parish Planner
Jefferson

Elwin - survey
benchmark
Elevation

Set backs 20' on Jeff Hwy
10' on Hwy DR
0' on property next to
Comercial
20' on Rear APEX to
residential

Hub cap

Floorplan

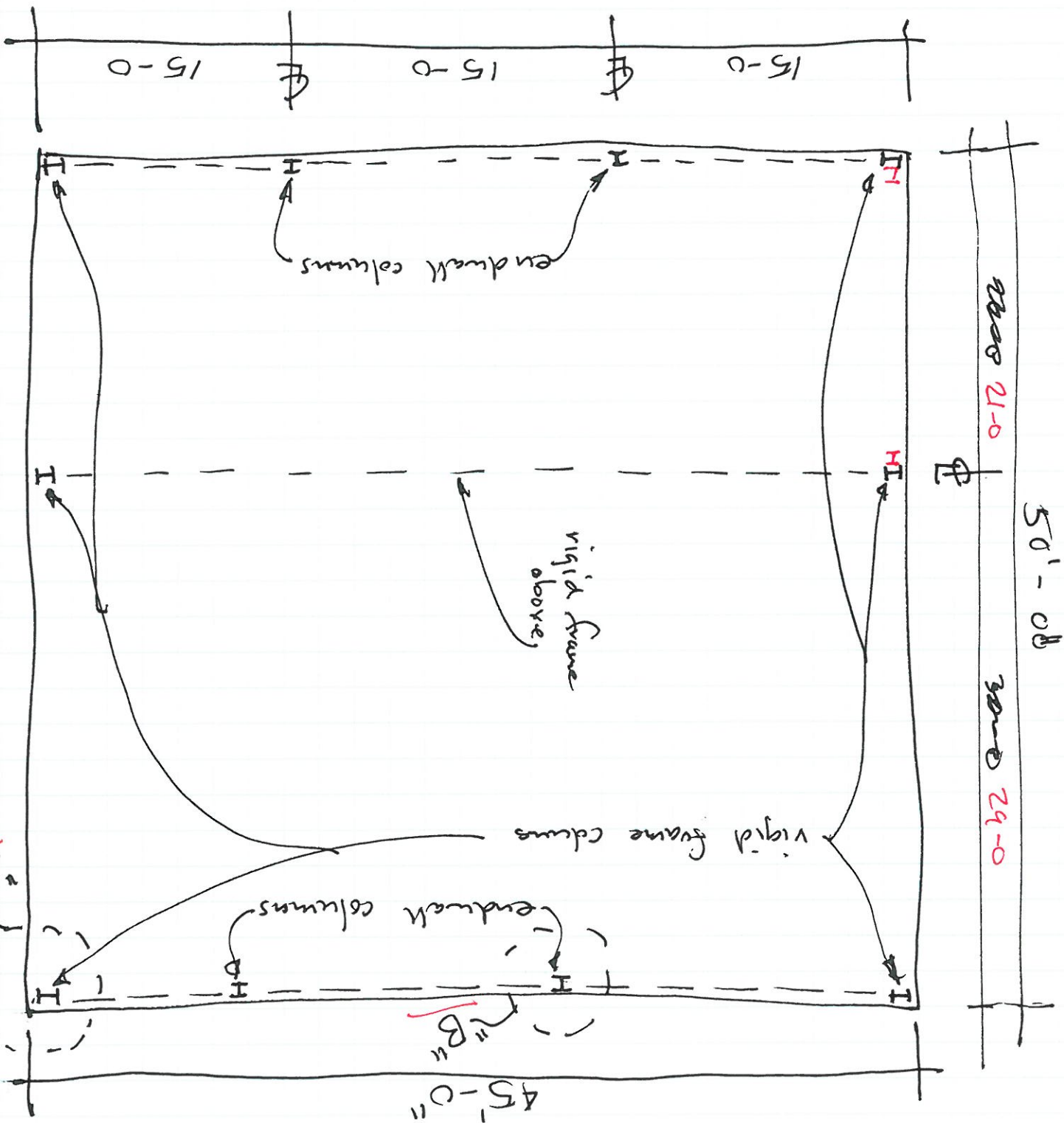

11 B 11 Endwall Column

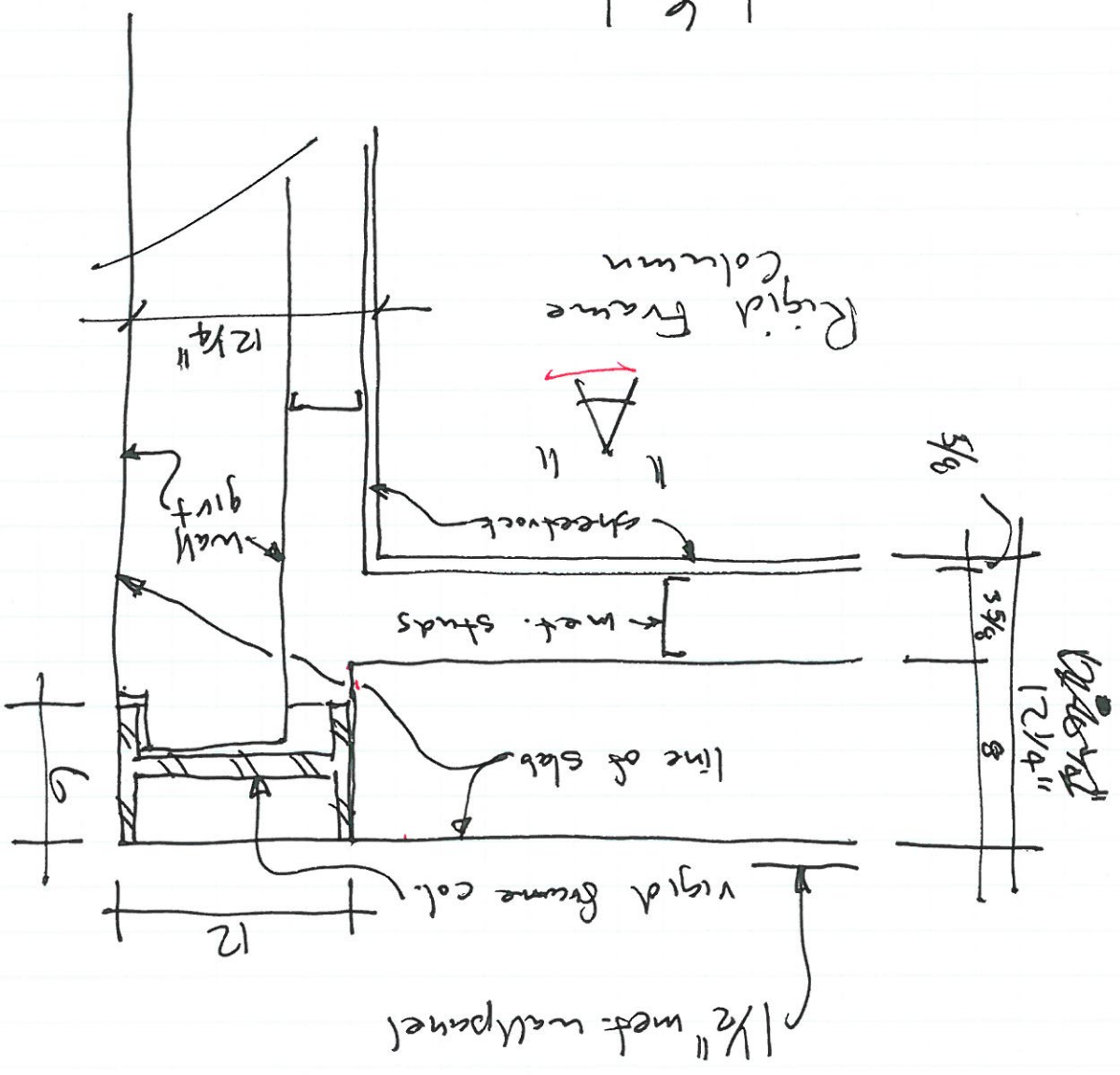
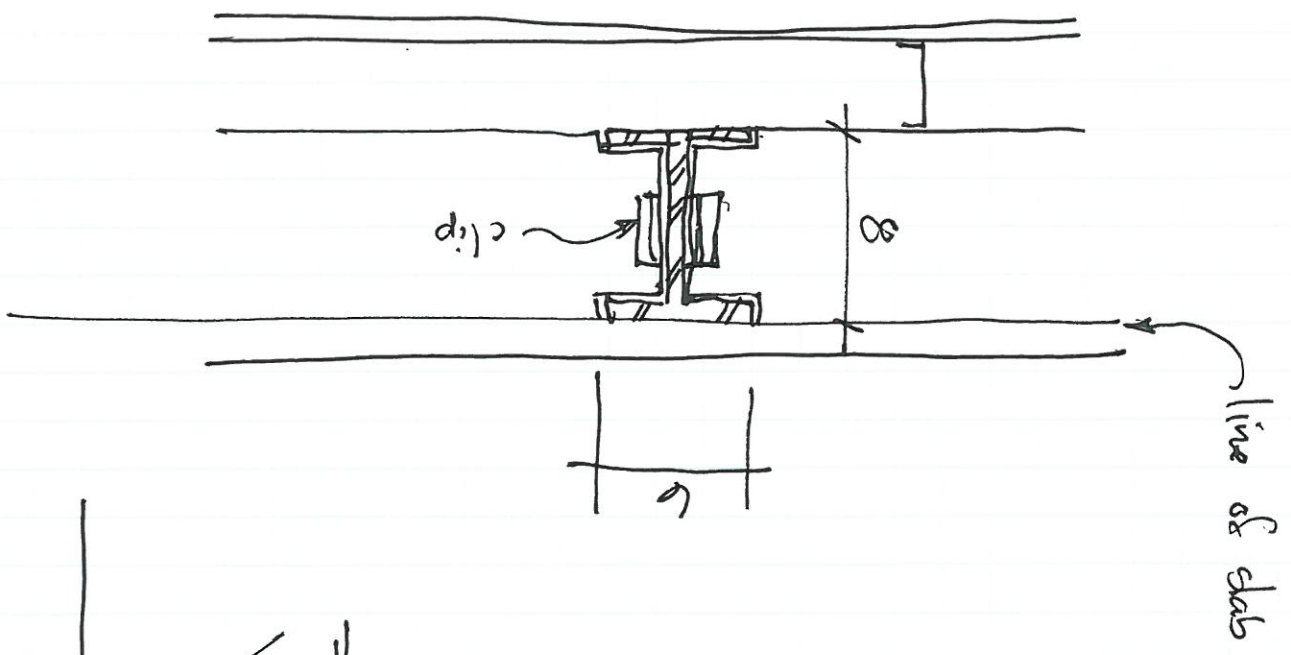

1 1/4 1/2

5/8
5/8
3 5/8
3 5/8
6
2

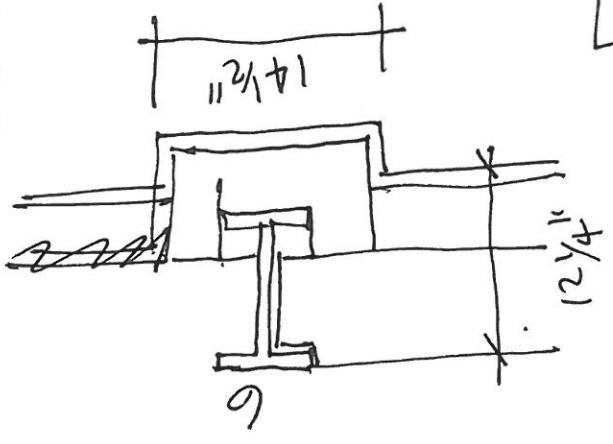

12 1/4

8 3/8
3 5/8
3 5/8
6 - 0
8 - 0

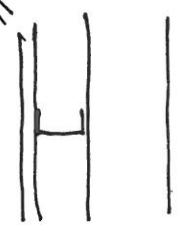

10 1/4

0
5/8
3
6
1



end wall columns

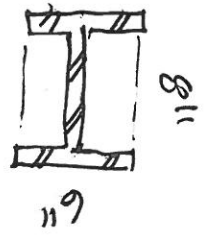

wall girft

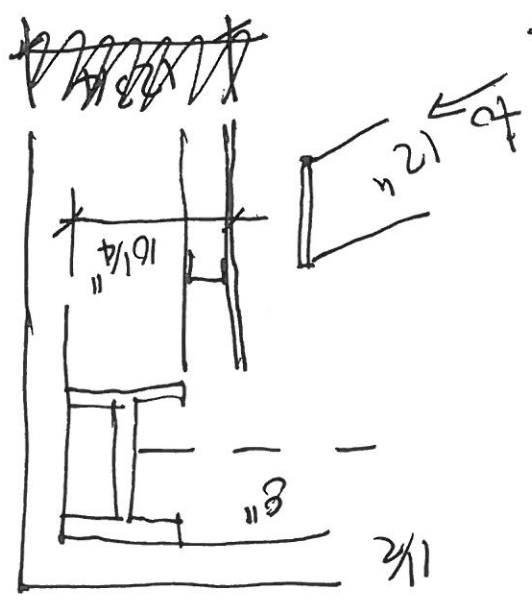
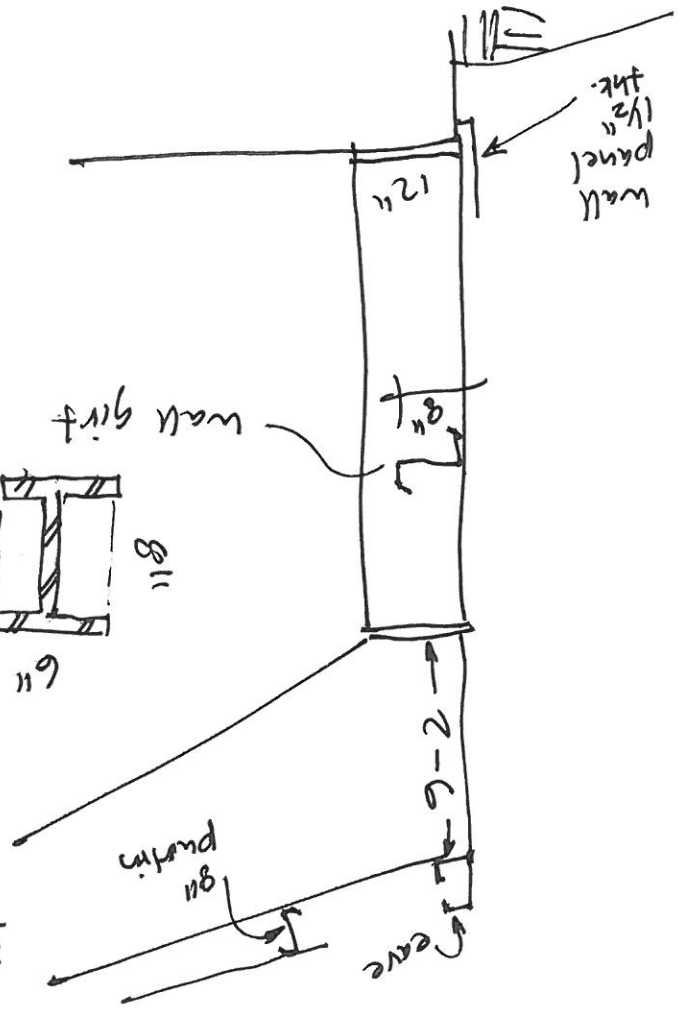

rigid frame column

