

PLAN

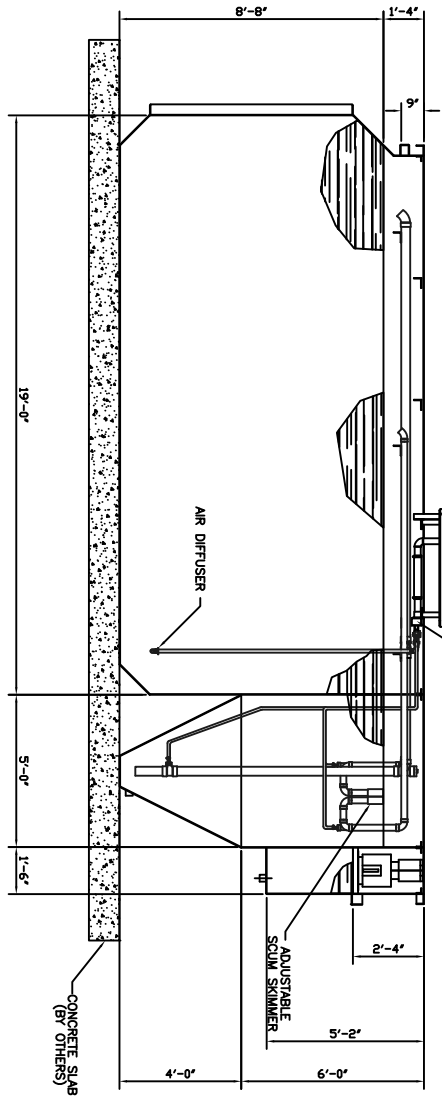

ELEVATION

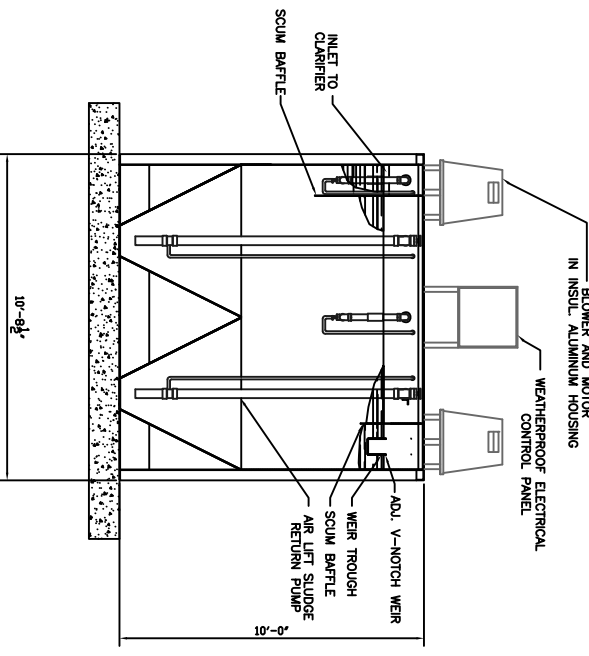

SECTION A-A

SHIPMENT WEIGHT	OPERATING WEIGHT	CHLORINE TANK
14,000 LBS.	135,000 LBS.	VOLUME: 317 GALS DETENTION: 39 MIN. @ AVERAGE FLOW
		VOLUME: 2,110 GALS DETENTION: 4.2 HRS. RISE RATE: 242 GPD/SF WEIR RATE: 1,350 GPD/FT.
		VOLUME: 12,204 GALS DETENTION: 24.6 HRS. AIR PROPANES: 4 TOTAL DIFFUSERS: 18 TOTAL

- NOTES:
- 1) CHLORINATOR TYPE _____
 - 2) SKIMMER LINES AND SLUDGE RETURN LINES SHALL BE SCH. 80 PVC.
 - 3) TWO (2) 3/4" HP OPEN DRIP PROOF ELECTRIC MOTORS _____ VOLT _____ PHASE _____ Hz.
 - 4) TWO (2) POSITIVE DISPLACEMENT ROTARY BLOWERS OPERATING AT _____ CFM AND _____ P.S.I.
 - 5) BIOLOGICAL LOADING: 20.33 LBS. BOD AT 200 PPH.

12,000 GPD SEWER TREATMENT PLANT MODEL A-12.0 TYPICAL CONFIGURATION

DATE: 1/27/95
 DESIGNED BY: T. Jones
 SCALE: 1/2"=1'-0"

Delta Environmental Products, Inc.
 DENHAM SPRINGS, LOUISIANA

NO.	DATE	BY	CHK'D	APP'D	REVISIONS

REFERENCE DRAWING NO. _____