

PLUMBING LEGEND

- LAV LAVATORY
- WC WATER CLOSET
- VENT PIPE
- ⊕ P-TRAP
- FD FLOOR DRAIN
- MH WATER HEATER
- MF WATER FOUNTAIN
- SANITARY SEWER
- COI WALL CLEAN OUT

10 PARTIAL PLUMBING PLAN

SCALE: 1/4"=1'-0"

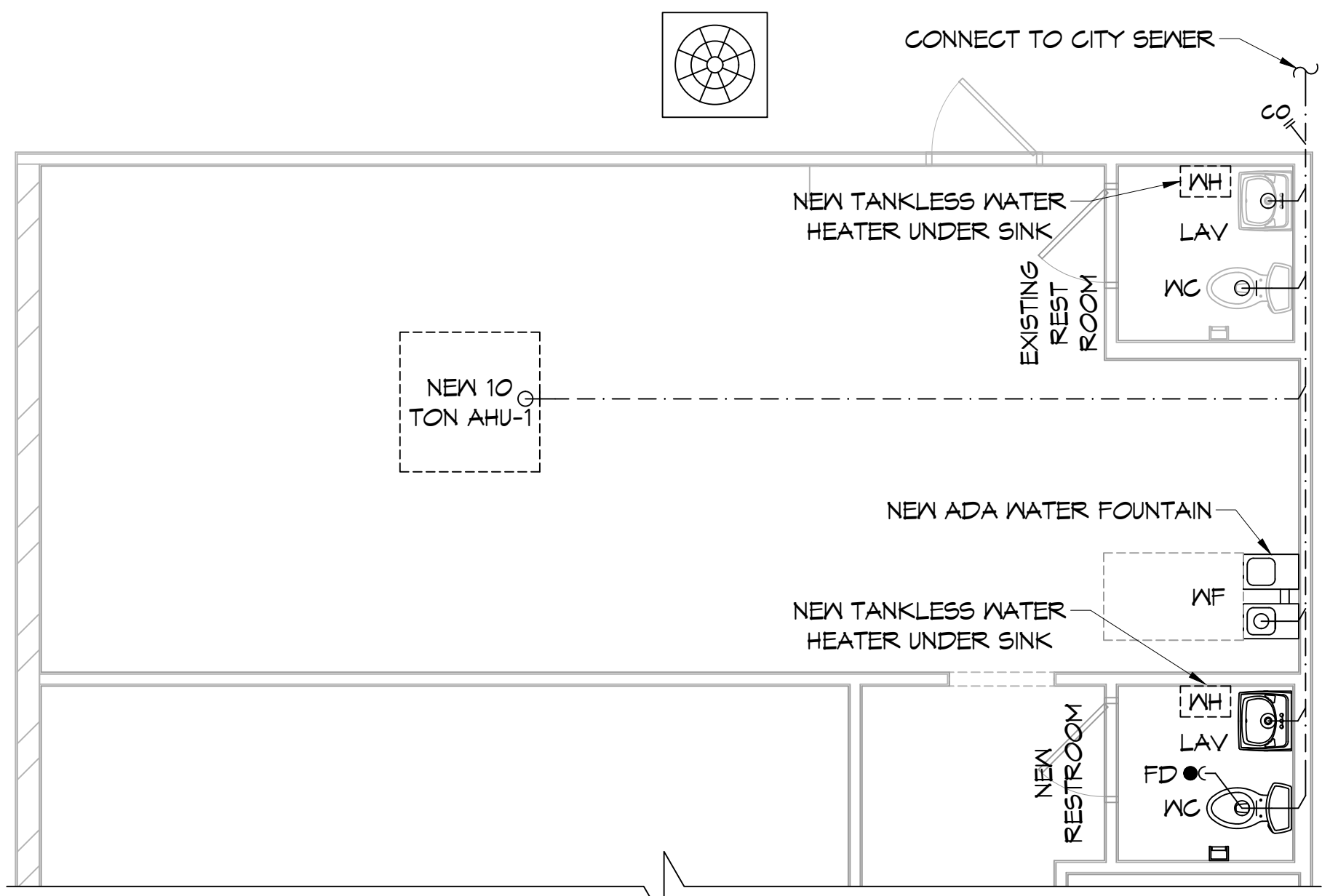

11 PLUMBING RISER DIAGRAM

SCALE: N.T.S.

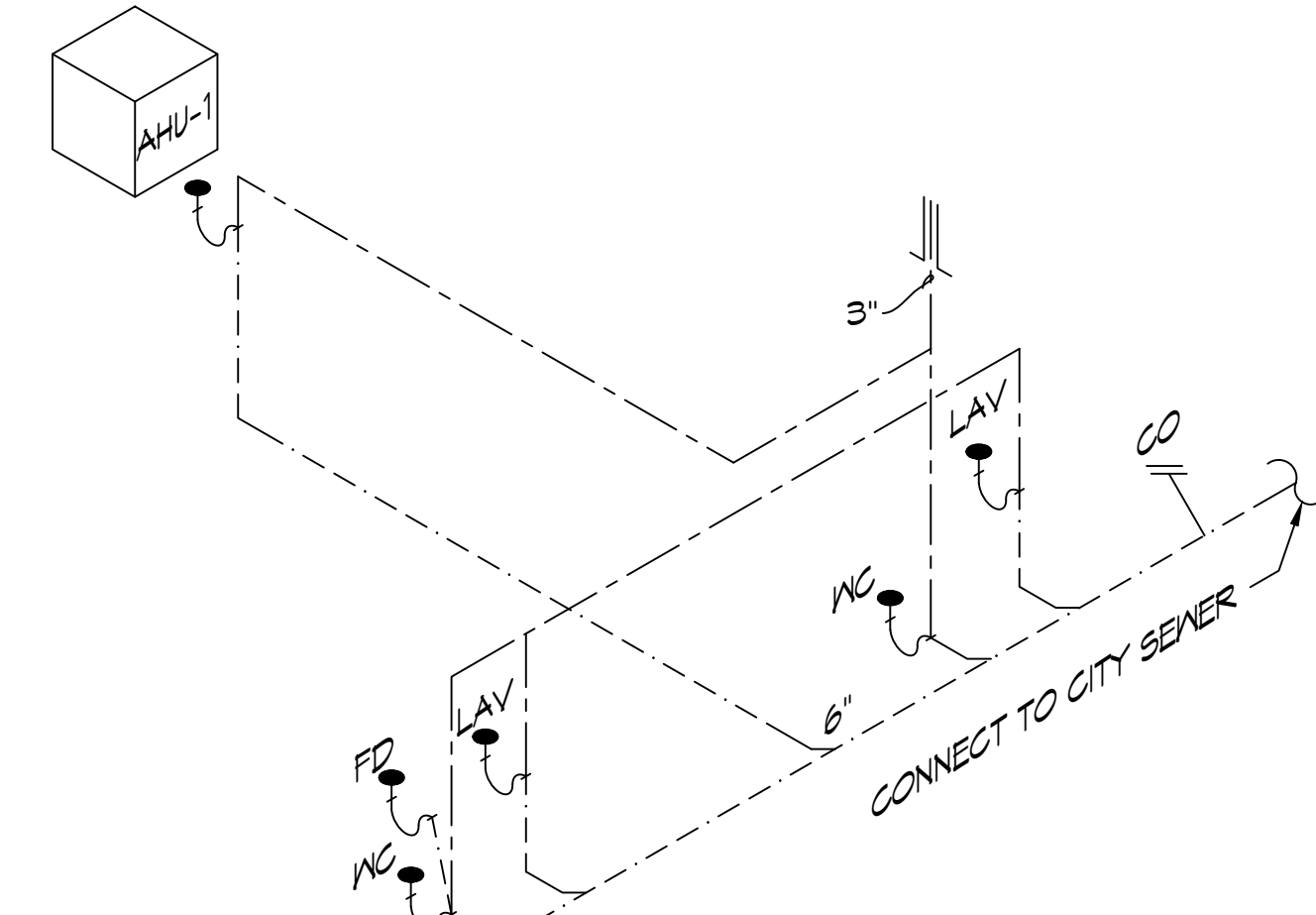

PLUMBING DETAILS

SCALE: N.T.S.

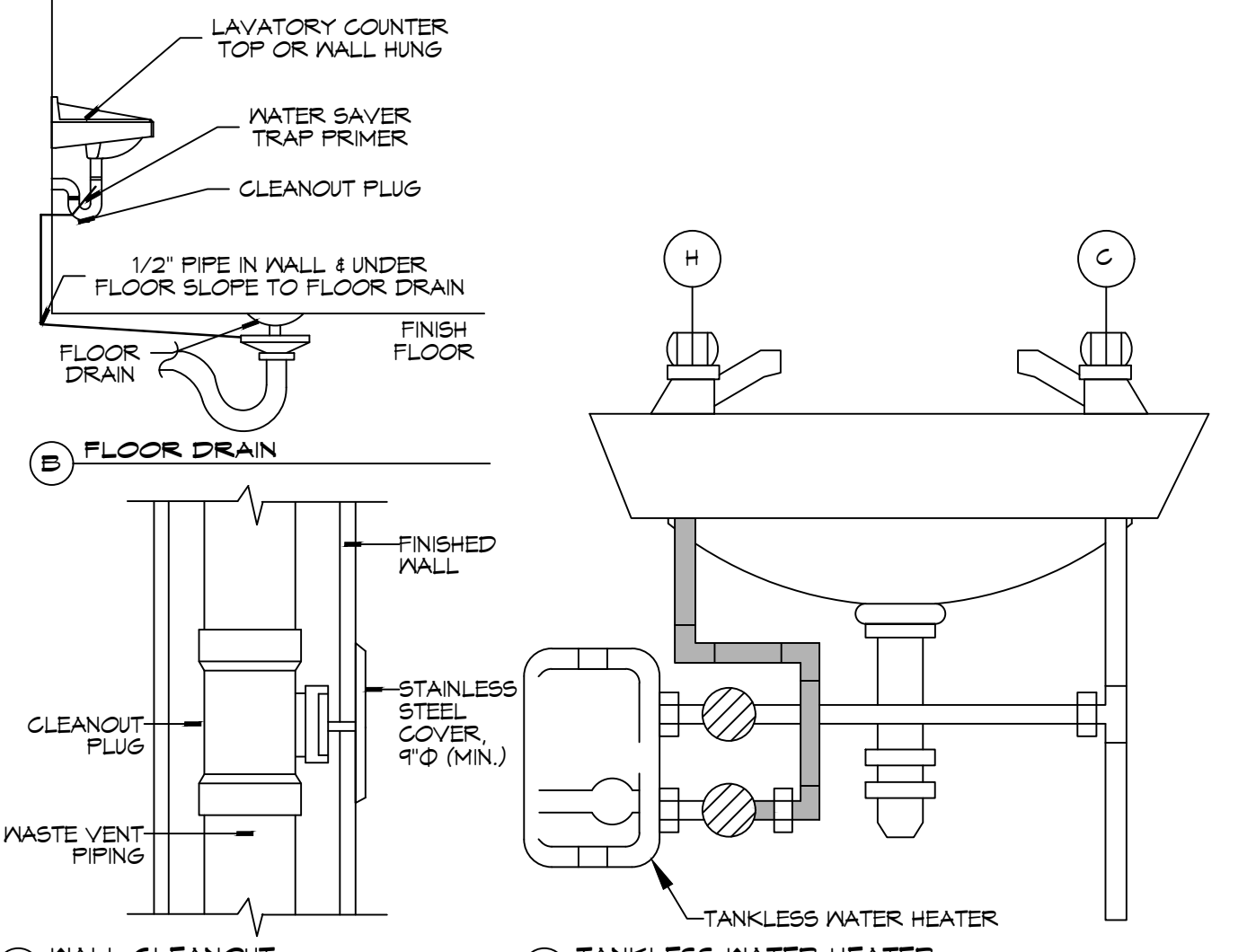

12 MECHANICAL PLAN

SCALE: 3/16"=1'-0"

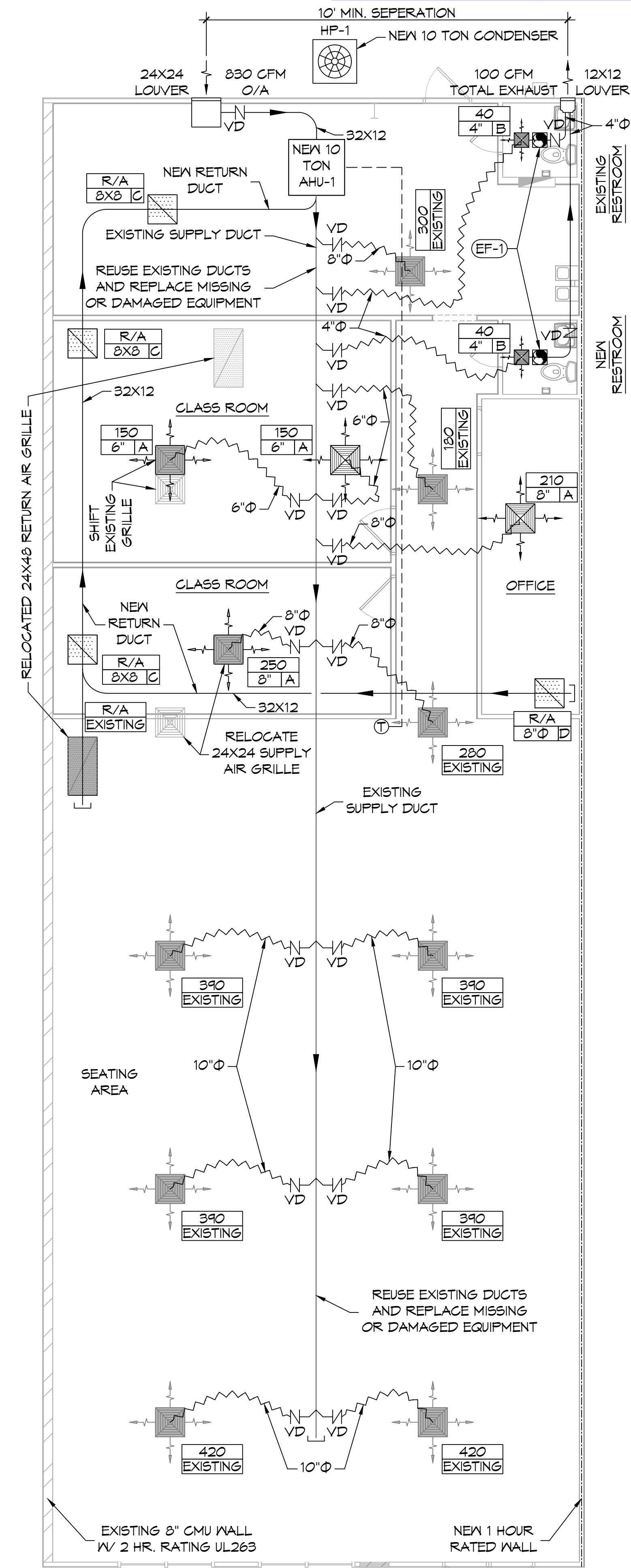

A/C SCHEDULE															
TAG	TRANE MODEL NO.	NOMINAL TONS	TOTAL CFM	OA CFM	COOLING		Motor HP	ESP (\"WC)	POWER VAC PH	HEAT PUMP					
					TMBH	SMBH				TAG	TRANE MODEL NO.	POWER VAC PH	REMARKS		
AHU-1	TWE12043A	10	4000	830	127	99	2	0.4	230	3	HP-1	TVA12043A	230	3	1, 2, 3, 4

DIFFUSER SCHEDULE				
TAG	SERVICE	NECK SIZE	DESCRIPTION	REMARKS
A	Supply Air	Ref. Plan	24" x 24" Perforated Ceiling Diffuser, Metalaire 7500	1, 2, 3
B	Supply Air	Tef. Plan	12" x 12" Perforated Ceiling Diffuser, Metalaire 7500	1, 2, 3
C	Return Air	Ref. Plan	24" x 24" Perforated Return, Metalaire 7500R	1, 2, 3

Exhaust Fan Schedule									
Tag	Service	Airflow (CFM)	TSP (\"we)	Watts	Volts	Phase Hz	Make / Model	Remarks	
EF-1	Restroom Exhaust	50	0.1	18	120	1	60	NuTone 50NT	1

MECHANICAL LEGEND

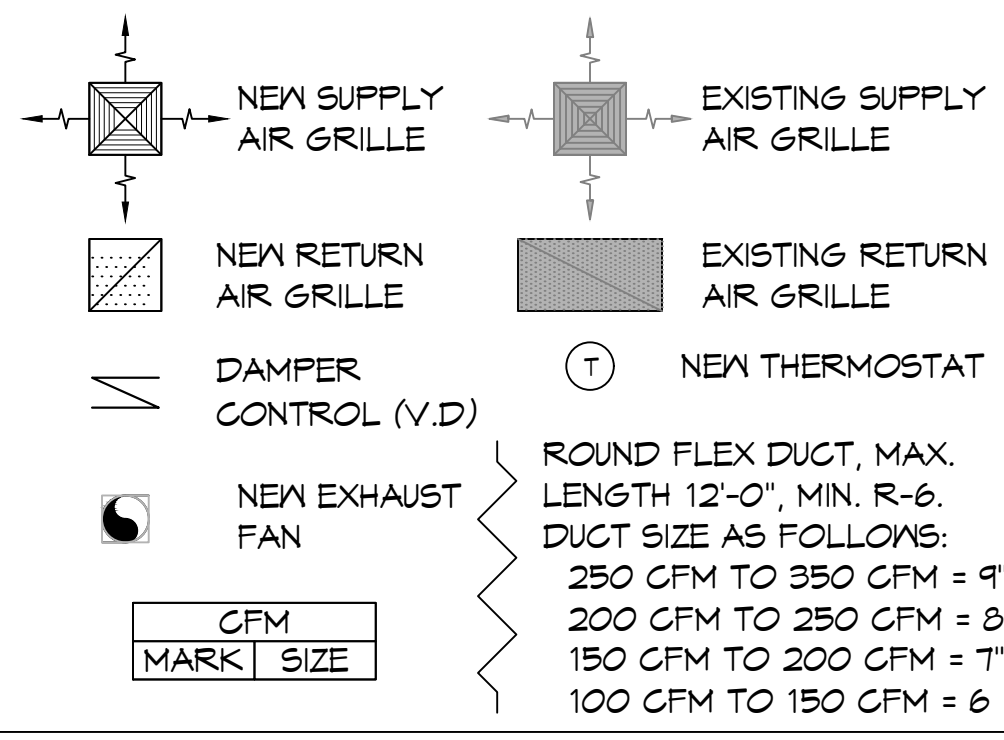

GENERAL PLUMBING NOTES

- PLUMBING LINES SHOWN ARE DRAWN DIAGRAMMATIC IN NATURE AND REPRESENT CONCEPTUAL ROUTING ONLY. CONTRACTOR IS RESPONSIBLE FOR FIELD VERIFICATION OF ALL ACTUAL CONDITIONS.
- PROVIDE ALL LABOR, MATERIAL, TRANSPORTATION, SUPERVISION, CLEAN-UP, SERVICES, AND EQUIPMENT FOR A COMPLETE OPERATING SYSTEM. THE SYSTEM SHALL INCLUDE HOT AND COLD WATER PIPING, SEWER AND VENT PIPING, INSULATION, WATER HEATER, HANGERS, VALVES, SUPPORTS WITHOUT ANY RESTRICTIONS TO VOLUME, CUT AND PATCH AS REQUIRED TO INSTALL PIPES.
- ALL WORK AND MATERIAL SHALL CONFORM STRICTLY TO THE LATEST LOCAL CITY, PARISH, STATE AND NATIONAL GOVERNING CODES, MUST MEET LA STATE PLUMBING CODE 2019 REQUIREMENTS.
- CONTRACTOR IS TO FIELD VERIFY ALL EXISTING UTILITY LOCATIONS, ELEVATIONS AND SIZES PRIOR TO COMMENCING ANY WORK. CONTRACTOR SHALL PAY NECESSARY FEES FOR THE UTILITIES CONNECTIONS.
- CONTRACTOR IS RESPONSIBLE TO VERIFY THE EXISTING INVERTS AND SET NEW INVERTS OF SEWERAGE AND DRAINAGE PIPES.
- SEWERAGE LINES 3-INCH AND SMALLER SHALL BE SLOPED 1/4" PER FOOT AND LINES 4-INCH AND LARGER SHALL BE 1/8" PER FOOT.
- TEST ALL PIPING AT REQUIRED PRESSURE.
- ALL PLUMBING SHALL BE CLOSELY COORDINATED WITH STRUCTURAL, MECHANICAL SYSTEM AND ELECTRICAL SYSTEMS TO INSURE NO TRADES WILL CONFLICT WITH EACH OTHER.
- DO NOT SCALE DRAWINGS. SEE ARCHITECTURAL DRAWINGS FOR EXACT LOCATIONS OF DOORS, WINDOWS, WALLS, FIXTURES, ETC.
- ALL WATER MAINS AND PIPING NOT SHOWN FOR CLARITY, ALL LOCATIONS FIELD VERIFIED.
- DOMESTIC HOT AND COLD WATER PIPING AND FITTINGS UNDER SLAB SHALL BE ASTM B88 COPPER WATER TUBE, TYPE K, SOFT ANNEALED. NO JOINTS SHALL BE ALLOWED UNDER THE SLAB.
- DOMESTIC WATER PIPING AND FITTINGS ABOVE THE SLAB SHALL BE ASTM B88 COPPER WATER TUBE, TYPE L, HARD DRAWN WITH COPPER PRESSURE TYPE FITTINGS, ANSI B16.22. THE JOINTS SHALL BE SOLDERED TYPE USING ASTM B32, ALLOY GRADE #5A (#5-B) SOLDER.
- SOIL, WASTE, VENT PIPING AND FITTINGS ABOVE THE SLAB SHALL BE SERVICE WEIGHT CAST IRON PIPE WITH BELL AND SPIGOT ENDS AND ONE PIECE NEOPRENE INSERT TYPE GASKET. USE PVC SCHEDULE 40 OR ABS DRY PIPES AND FITTINGS WHERE PERMITTED BY CODE.
- ALL WATER PIPING AND FITTINGS ABOVE THE FLOOR SHALL BE INSULATED WITH 1/2" THICK FIBERGLASS INSULATION AND JACKET.
- ALL ELECTRICAL, MECHANICAL AND PLUMBING ELEMENTS PENETRATING FIRE PARTITIONS SHALL BE FIRE CAULKED. (PENETRATIONS THROUGH RATED CONSTRUCTION SHALL BE SEALED WITH A MATERIAL CAPABLE OF PREVENTING THE PASSAGE OF FLAMES AND HOT GASES WHEN TESTED IN ACCORDANCE WITH ASTM-E814.)
- SEE ROOF PLAN FOR PLUMBING ROOF PENETRATIONS. ROUTE VENT PIPES IN ATTIC AS NECESSARY.
- ALL VENTS THROUGH ROOF (VTR) SHALL BE LOCATED A MINIMUM OF 10'-0" FROM ANY MECHANICAL OR NATURAL AIR INTAKE.

GENERAL HVAC NOTES

- CONGEALED DUCTWORK TO BE GALVANIZED SHEET METAL WRAPPED WITH FIBROUS GLASS DUCT WRAP WITH FSK VAPOR BARRIER, MIN R-6. INSTALLED PER SMACNA STANDARDS. DUCT WORK IMMEDIATELY DOWNSTREAM FROM RTU SHALL BE LINED FOR SOUND ATTENUATION.
- EXPOSED DUCTWORK TO BE GALVANIZED SHEET METAL LINED WITH FIBROUS GLASS DUCT LINER, MIN R-6. INSTALLED PER SMACNA STANDARDS.
- ROUND FLEXIBLE DUCT TO BE UL-101, CLASS 1, AIR DUCT MATERIALS.
- DUCT SIZES SHOWN ARE CLEAR INSIDE DIMENSIONS.
- IN ALL SYSTEMS OVER 2000 CFM AND LESS THAN 15,000 CFM, SMOKE DETECTORS SHALL BE INSTALLED IN ACCORDANCE WITH NFPA 72E IN THE RETURN DUCT DOWNSTREAM OF THE AIR HANDLING UNIT AND ALL FILTERS TO AUTOMATICALLY STOP THE FAN.
- PROVIDE UL LISTED 125 F FIRESTAT IN RETURN AIR OF EACH SYSTEM UNDER 2000 CFM TO SHUT DOWN THE FAN IN THE EVENT OF FIRE.
- PROVIDE UL RATED FIRE DAMPERS WHERE REQUIRED AT ALL DUCT PENETRATIONS OF FIRE-RATED ASSEMBLIES AND WHERE REQUIRED BY CODE, INCLUDING OUTSIDE AIR INTAKES AND EXHAUST FANS.
- CONDENSATE DRAINS TO BE PVC PIPE RUN TO PLUMBERS P-TRAP WITH FIVE FEET OF AIR HANDLING UNITS.
- ALL AIR HANDLING SYSTEMS TO BE BALANCED TO ASSURE PROPER AIR FLOWS PER PLANS.
- ALL THERMOSTATS TO BE AUTOMATIC CHANGEOVER WITH HEAT SWITCH.
- EXHAUST FAN SHALL BE CONTROLLED BY A SWITCH ON THE WALL IN THE SAME LOCATION AS LIGHT SWITCH(S). PROVIDE BACK DRAFT DAMPER.
- PROVIDE AND INSTALL WATER PROOF GRILLE VENT IN PROPER ROOF LOCATION FOR PLUMBING FIXTURE EXHAUST.
- ALL SUPPLY AIR VENTS SHALL BE EQUIPPED WITH AIR CONTROL DAMPERS AT THE REGISTER.
- LOCATE OUTDOOR UNITS AS SHOWN ON ARCHITECTURAL DRAWINGS.
- REFRIGERANT LINES SHALL BE SIZED BY UNIT MANUFACTURER AND INSTALLED ACCORDING TO MANUFACTURER'S INSTRUCTIONS.
- FRESH AIR SHALL BE SUPPLIED TO EACH AIR HANDLER THROUGH EXTERIOR WALL DUCT SUPPLIED WITH A CONTROL DAMPER.
- ALL ELECTRICAL, MECHANICAL, AND PLUMBING PENETRATING FIRE WALLS SHALL BE FIRE CAULKED. (PENETRATIONS THROUGH RATED CONSTRUCTION SHALL BE SEALED WITH A MATERIAL CAPABLE OF PREVENTING THE PASSAGE OF FLAMES AND HOT GASES WHEN TESTED IN ACCORDANCE WITH ASTM-E814.)
- ALL MECHANICAL SYMBOLS ARE DRAWN DIAGRAMMATICALLY. CONTRACTOR TO VERIFY WITH OWNER LOCATIONS OF VENTS, DAMPERS, REGISTERS, ETC.
- FLEXIBLE DUCTWORK LENGTH NOT TO EXCEED 12'-0". SUPPORT FLEX DUCT TO PREVENT SAGGING.
- REFER TO REFLECTED CEILING PLAN FOR FINAL GRILLE AND DIFFUSER LOCATIONS AND COORDINATE AS REQUIRED.
- FINAL LOCATION OF TEMPERATURE CONTROLS TO BE COORDINATED WITH OWNER AT JOB SITE.
- PROVIDE AND INSTALL SMOKE DETECTORS AS APPROVED BY LOCAL A.H.J.S. PLACE NEAR R/A AND S/A OPENINGS OF AHU AND PROVIDE, WITH ACCESS PANEL, WIRING BY ELECTRICAL CONTRACTOR.
- FRESH AIR INTAKES ARE REQUIRED TO HAVE MOTORIZED OR GRAVITY DAMPERS TO SHUT OFF WHEN SYSTEM IS NOT RUNNING.
- PROVIDE BIRD SCREENS AT ALL EXTERIOR MECHANICAL PENETRATIONS.
- COORDINATE WALL MOUNTED THERMOSTAT LOCATIONS WITH ALL OWNER FURNISHED ITEMS EITHER WALL MOUNTED OR FLOOR MOUNTED AGAINST PARTITIONS. REFER TO ARCHITECTURAL DRAWINGS.
- SEE ROOF PLAN FOR ALL ROOF PENETRATIONS.
- PROVIDE MIN 10 GA GALVANIZED SHEET METAL TO BLANK-OFF GABLE VENTS WHERE INTAKE/EXHAUST DUCTS OCCUR.

NOTE: REUSE EXISTING DUCTS. REPLACE MISSING OR DAMAGED EQUIPMENT. VERIFY ALL EXISTING COMPONENTS

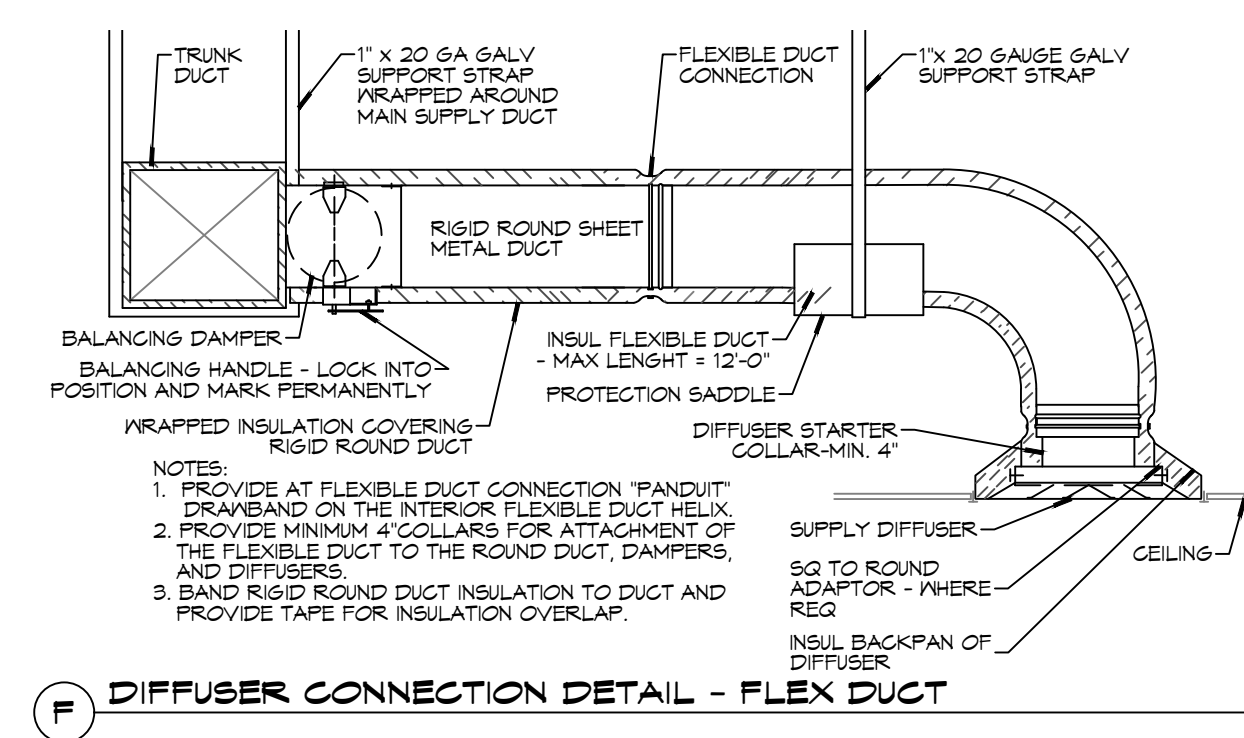
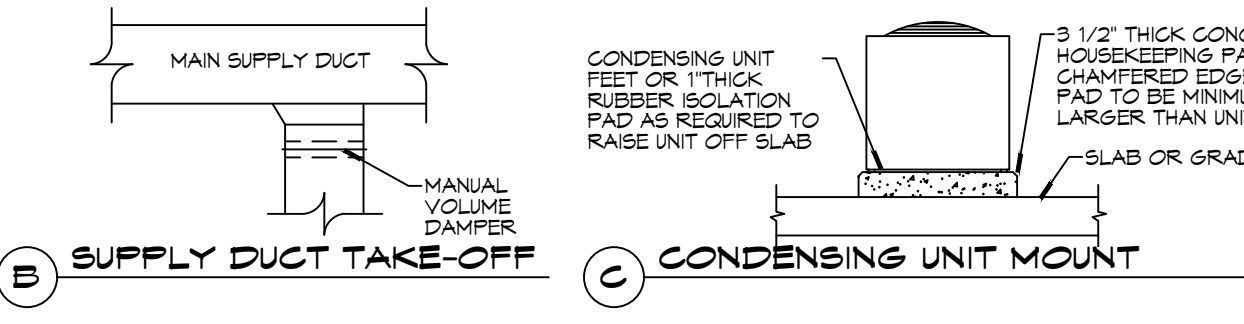
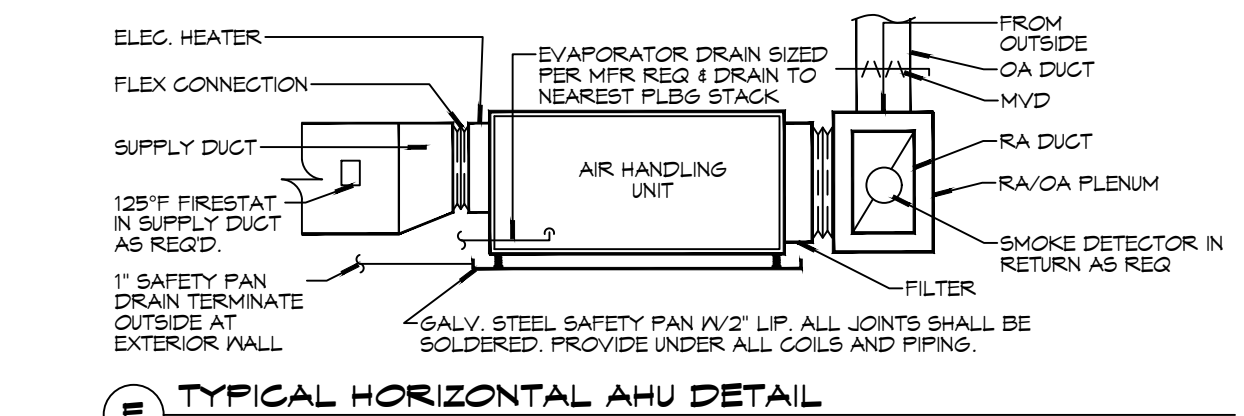

DAMMON ENGINEERING, INC.
LOUISIANA & MISSISSIPPI
Chief Engineer: Brian M. Wierich, PE
554 Old Spanish Trail
Slidell, LA 70458
PH: 985.649.5832 F: 985.641.9590
info@dammoneengineering.com

#	DESCRIPTION	DATE



LESIA CRISTIANO
LESIA DE CRISTIANO
1000 CARUSO BLVD., SUITE 100
SLIDELL, LA 70451
JOB No: 2454 DATE: 12/02/2023
DRAWN BY: TMT CHECKED BY: GAC
SHEET TITLE: PLUMBING AND MECHANICAL PLAN
DRAWING NUMBER: PM101
SHEET No: 4 of 5

