

# DAMMON ENGINEERING, INC.

dammonengineering.com

*CONSULTING*

*DESIGN*

*STUDIES*

*EXPERT WITNESS*

554 Old Spanish Trail  
Slidell, LA 70458

P.O. Box 2830  
Slidell, LA 70459

985-649-5832  
FAX 985-641-5950

November 16, 2011

To: Hunter Charbonnet  
Casey Civil, LLC  
1080 Old Spanish Trail, Ste.8  
Slidell, LA 70458

REF: Roof Curb Calculations  
PNK Support Facility  
Baton Rouge, LA

Dear Mr. Charbonnet,

Dammon Engineering was contacted to verify adequate structural support for various roof mounted equipment for the above referenced project.

Equipment:

- United Intertech Intake Ventilation Hood = Approx 680lbs.
- Twin City Fan & Blower Exhaust Fans:  
Various sizes, calculations are based on heaviest hood = 165lbs.

Assumptions:

- Roof curb bearing on a minimum of 2 Horizontal Z-shape (Z8.50x0.105) roof purlins
- Maximum Deflection of Purlins =  $L/360$
- Placement of Roof Curbs as shown on Sheet FA1.00 (attached)

The proposed Roof curb Supports are approved as shown in the attached calculations. Install all framing and roof curb components per manufacturer requirements to provide a complete curb system.

Sincerely,

Emmett G. Dammon, P.E.  
Dammon Engineering



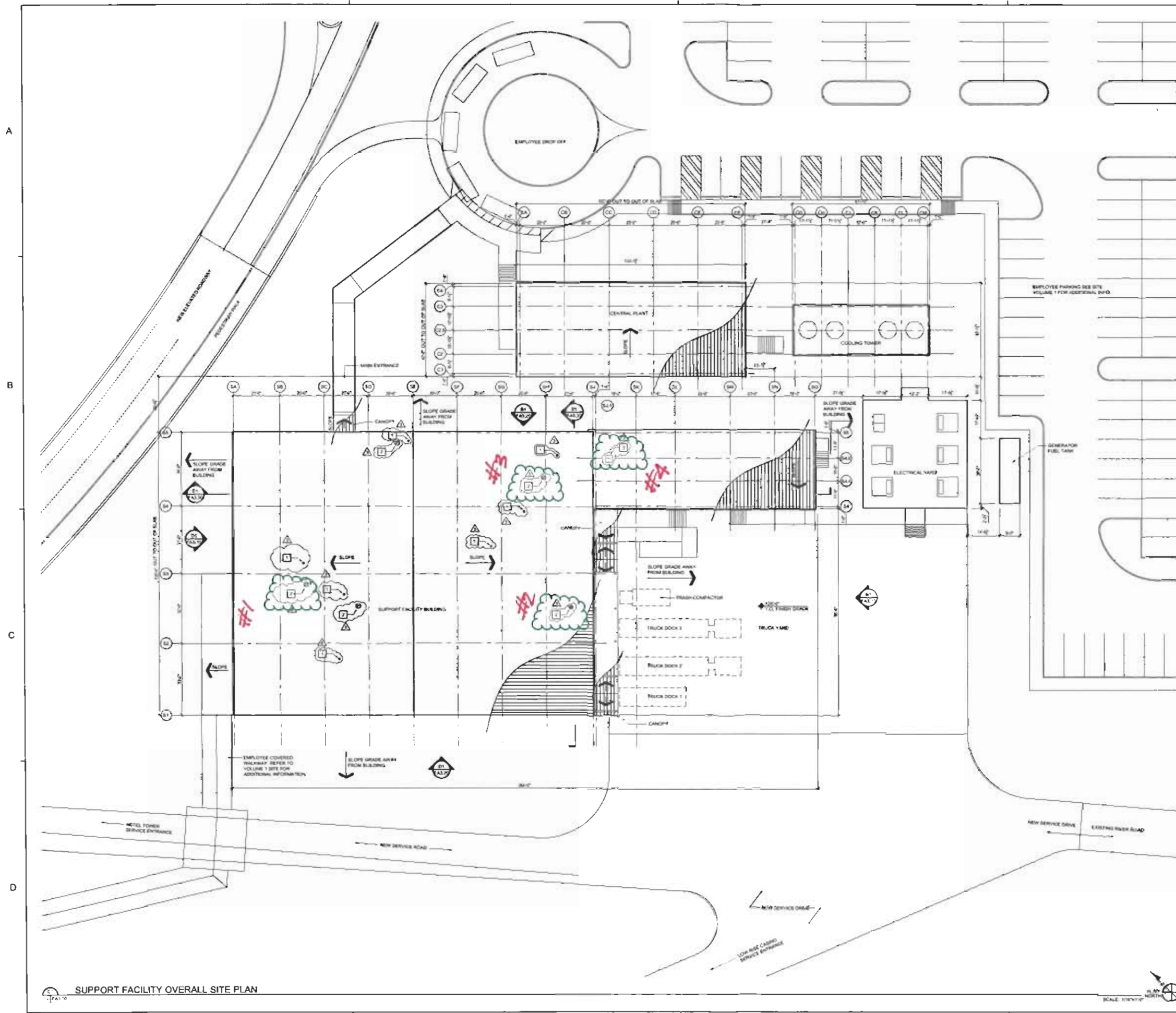

**GENERAL NOTES:**

- SEE SHEET 01-11 FOR SITE COORDINATES FOR THE SUPPORT FACILITY BUILDING. THE CENTRAL PLANT DIMENSIONS FROM THE SUPPORT FACILITY LOCUS.
- SEE SITE VOLUME 1 FOR GRADING, UNDERGROUND UTILITIES AND AREA SITE WORK.
- UNDERGROUND PIPING SHALL BE INSTALLED IN ACCORDANCE WITH CHAPTER 15. SEE 108 FOR SPECIFIC REQUIREMENTS FOR PIPING RUN UNDER BUILDINGS. FIRE PUMP, IF PROVIDED TO MEET THE REQUIREMENTS OF NFPA 20 2007 EDITION.

**PLAN KEYNOTES**

- 1 AIR
- 2 EXHAUST / 1/2"
- 3 EXHAUST VENT ON ROOF CURB

THESE PLANS HAVE BEEN PREPARED UNDER MY DIRECT SUPERVISION AND TO THE BEST OF MY KNOWLEDGE COMPLY WITH THE INTERNATIONAL BUILDING CODE. I WILL OBSERVE THE WORK.

**MARNELL ARCHITECTURE**  
ARCHITECTS INC. - PLANNING - DESIGN

**MANNING ARCHITECTS**  
ARCHITECTURE INTERIORS | PLANNING

1100 W. WASHINGTON BLVD. SUITE 1000  
LAS VEGAS, NEVADA 89102  
TEL: 702.441.2000 FAX: 702.441.2001

**PNK (BATON ROUGE) PARTNERSHIP**  
8918 SPANISH RIDGE AVENUE  
LAS VEGAS, NEVADA 89148

DATE	ISSUED FOR
11/12/10	PROGRESS PACKAGE
11/18/10	CONCEPT PHASING
12/21/10	D. O. PACKAGE
02/28/11	CONSTRUCTION
04/28/11	AIR SIDE
05/11/11	AIR SIDE
08/01/11	AIR SIDE

THESE PLANS HAVE BEEN PREPARED UNDER MY DIRECT SUPERVISION AND TO THE BEST OF MY KNOWLEDGE COMPLY WITH THE INTERNATIONAL BUILDING CODE. I WILL OBSERVE THE WORK.



PROJECT NO. 11000000  
DRAWN BY P.J.K.  
CHECKED BY R.C.H.  
DRAWING TITLE  
**SUPPORT FACILITY  
OVERALL  
SITE PLAN**

SCALE 1/8"=1'-0"  
**FA1.00**

**SUPPORT FACILITY OVERALL SITE PLAN**

### Beam Deflection Calculations

Project: PNK Support Facility  
 Job#:

Location: #1  
 Date: 11/16/2011

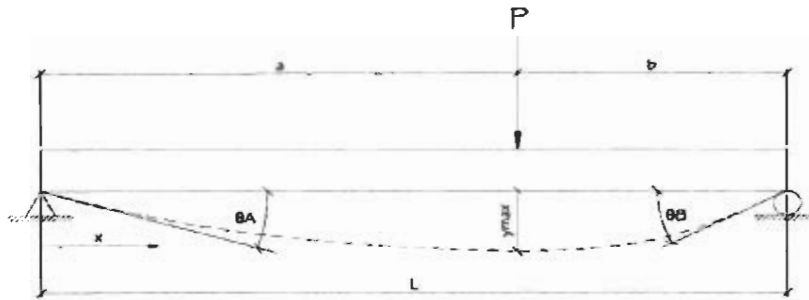

P=	0.0825 k	x=	240 in
L=	384 in		
E=	29000 ksi	y <sub>max</sub> = L/360 =	1.07 in
I=	14.67 in <sup>4</sup>		
a=	240 in		
b=	144 in		

$$y = \frac{Pa(L-x)}{6EIL}(x^2 + a^2 - 2Lx)$$

y= -0.20106 in OK

$$\theta_A = -\frac{Pb}{6EIL}(L^2 - b^2)$$

theta\_A= -0.00154 °

$$\theta_B = \frac{Pa}{6EIL}(L^2 - a^2)$$

theta\_B= 0.001815 °



### Beam Deflection Calculations

Project: PNK Support Facility  
 Job#:

Location: #2  
 Date: 11/16/2011

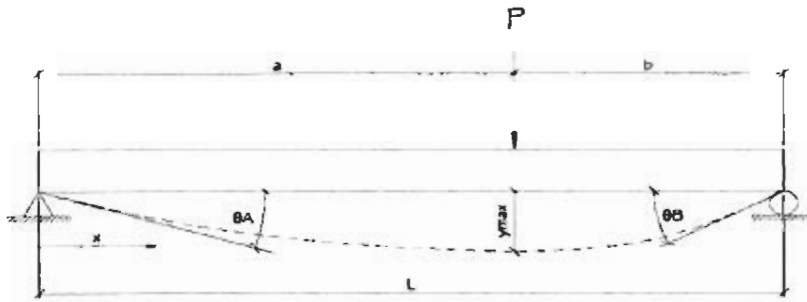

P=	0.0825 k	x=	216 in
L=	384 in		
E=	29000 ksi	y <sub>max</sub> = L/360 =	1.07 in
I=	14.67 in <sup>4</sup>		
a=	216 in		
b=	168 in		

$$y = \frac{Pa(L-x)}{6EIL}(x^2 + a^2 - 2Lx)$$

y = -0.22167 in      OK

$$\theta_A = -\frac{Pb}{6EIL}(L^2 - b^2)$$

theta\_A = -0.00169 °

$$\theta_B = \frac{Pa}{6EIL}(L^2 - a^2)$$

theta\_B = 0.001833 °



### Beam Deflection Calculations

Project: PNK Support Facility  
 Job#:

Location: #3  
 Date: 11/16/2011

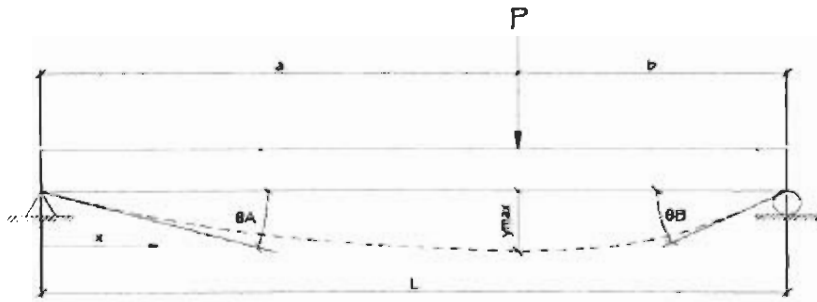

P=	0.0825 k	x=	216 in
L=	382 in		
E=	29000 ksi	y <sub>max</sub> = L/360 =	1.06 in
I=	14.67 in <sup>4</sup>		
a=	216 in		
b=	166 in		

$$y = \frac{Pa(L-x)}{6EIL}(x^2 + a^2 - 2Lx)$$

y = -0.21755 in      OK

$$\theta_A = -\frac{Pb}{6EIL}(L^2 - b^2)$$

theta\_A = -0.00166 °

$$\theta_B = \frac{Pa}{6EIL}(L^2 - a^2)$$

theta\_B = 0.001814 °



### Beam Deflection Calculations

Project: PNK Support Facility  
 Job#: \_\_\_\_\_

Location: #4  
 Date: 11/16/2011

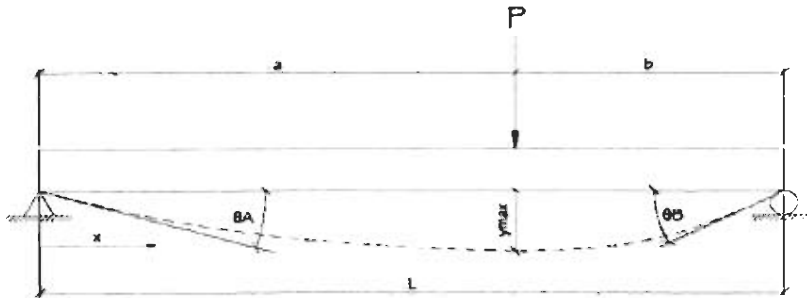

P=	0.35 k	x=	144 in
L=	218 in		
E=	29000 ksi	y <sub>max</sub> = L/360 =	0.61 in
I=	14.67 in <sup>4</sup>		
a=	144 in		
b=	74 in		

$$y = \frac{Pa(L-x)}{6EIL}(x^2 + a^2 - 2Lx)$$

y = -0.14284 in      OK

$$\theta_A = -\frac{Pb}{6EIL}(L^2 - b^2)$$

θ<sub>A</sub> = -0.00196 °

$$\theta_B = \frac{Pa}{6EIL}(L^2 - a^2)$$

θ<sub>B</sub> = 0.002426 °





Fan Tag: EF F2  
 Job Name: Pinnacle Casino - Support Bldg  
 Job ID: 030211  
 Date: March 2, 2011  
 Page: Page 4 of 10



**BCRD - Centrifugal Roof Exhauster, Downblast, Belt Driven**

**CONSTRUCTION FEATURES**

- Backwardly curved, non-overloading wheel.
- Wheel, motor, and drive assembly are isolated from the fan supports by rubber isolators.
- Top cap provides quick access to the wheel, motor, and drive assembly.
- Re-greaseable pillow block ball bearings provide an average life of 500,000 hours.
- Curb cap/venturi assembly with welded corners.
- Entire fan assembly is balanced and tested.
- Galvanized birdscreen.
- Disconnect switch.

**FAN DESCRIPTION**

Qty	Type	Size	Wt (lb.)
1	BCRD	120D	165

Approximate weight each, includes fan, motor and accessories.

**FAN PERFORMANCE**

CFM	SP (in.wg)	RPM	Oper. BHP
1,250	0.625	1280	0.25

Temperature: 70°F, Altitude: 0ft

**MOTOR DATA**

HP	RPM	Volt/Ph/Hz	Encl
1/3	1750	115/1/60	ODP

Efficiency: Standard/EPACT

**SOUND DATA**

Octave Bands	1	2	3	4	5	6	7	8	LwA	dBA	Sones
Level at Inlet	68	70	74	74	70	64	59	52	75	61	11.2

LwA: The overall (single value) fan sound power level in dB re. 10<sup>-12</sup> Watts, 'A' weighted.

dBA: Estimated sound pressure level (re:0.0002 microbar) based on a single ducted installation at 5 ft., using a directivity factor of 1.

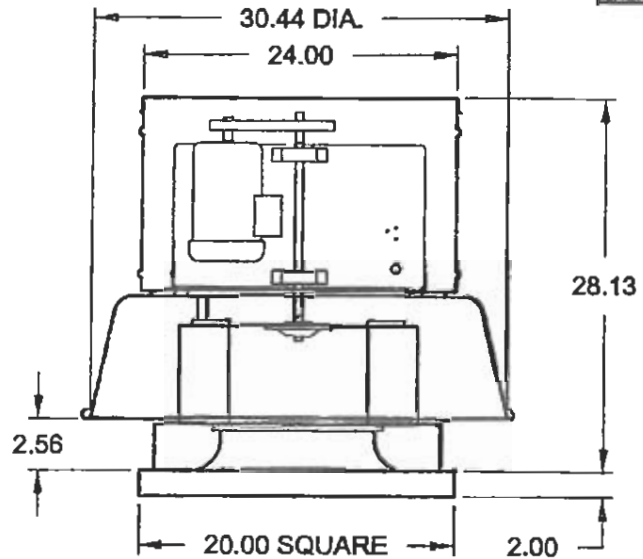

ROOF OPENING	14.50 X 14.50
DAMPER SIZE	14.00 X 14.00

**ACCESSORIES INCLUDED**

- Birdscreen - Galvanized
- Backdraft Damper
- Tie Down Brackets
- Roof Curb, Canted, Galv. w/ Insulation 18" H
- Disc Switch-Unfused (NEMA 1), Shipped Loose
- Fan Shaft Bearings to be Lubricated and Permanently Sealed

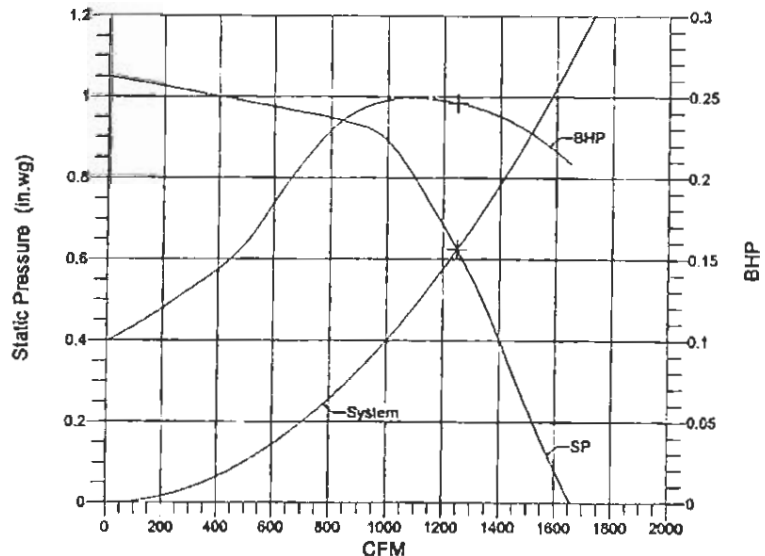

Intake Vent

3



(ENGINEERS)  
SUBMITTAL DATA

Ventilator Hoods

STANDARD SPECIFICATIONS

- HOOD: 16 ga. (.052") Mill Finish Aluminum
- BASE SECTION: 13 ga. (.090") Mill Finish Aluminum
- BIRDSCREEN: 1/2" x 1" (.051") Flattened Aluminum (2B)
- FINISH: Standard Mill
- MINIMUM SIZE: 12" x 12"
- MAXIMUM SIZE: 60" x 120"
- FRAMING: Under 12 Square Feet Hood Area:  
1-1/2" x 1-1/2" x .125" 6063-T6 Extruded Aluminum Angle - All Welded
- 12 Sq. Ft. through 40 Sq. Ft.:  
1-1/2" x 1-1/2" x .25" 6063-T6 Extruded Aluminum Angle - All Welded

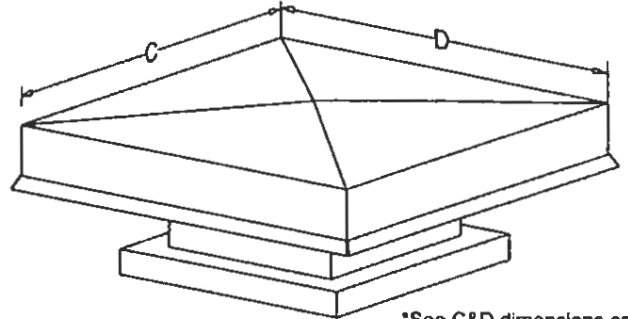

\*See C&D dimensions on following pages

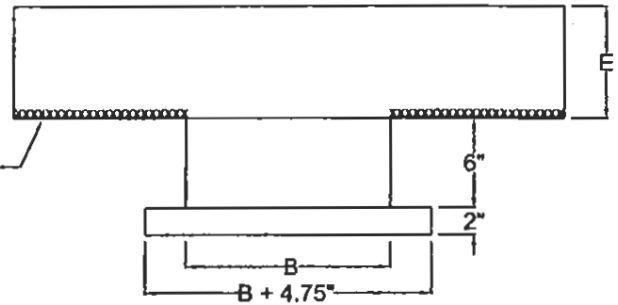
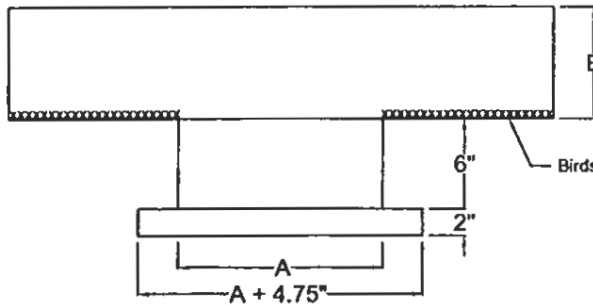

\*These drawings are for dimensional purposes and may not represent actual construction.

\*\* See Curb Cut Sheet to Follow

Tag	Qty.	A	B	Hood-Throat Ratio	Options
	1	59	59	2:1	with Curb
INTAKE VENT: APPROXIMATELY 680 LBS					

Options

- Insulated Internal Hood
  - Anti-Condensate Coating
  - 1" Fiberglass Insulation
- Hinged Lid (MAX 60" x 60" Throat)
- Insect Screen
- Roof Pitched - ( )/12"
- Galvanized Steel Construction
- 304 Stainless Steel Construction
- Powder Coating
  - Polyester
  - Fluoropolymer 70%
- Dampers (Backdraft or Motor Operated)
- Filter Racks
- Heavier Construction
- Additional Throat Height
- Hood Tie Downs (125 mph wind)

Job Name: Pinnacle Casino

Location:

Architect:

Engineer:

Contractor: Mechanical Construction

MODEL GEV (Exhaust)
 

- 1:1 Ratio (100%)
- 1:5 Ratio (150%)

MODEL GIV (Intake)
 

- 1.75:1 Ratio (175%)
- 2:1 Ratio (200%)

DRAWN BY: SRB      DATE: 12-03-99      REV. DATE: 8-31-09

REV. NO. 17      APPROVED BY: SDC      DWG. NO.: F-6

001-221319-0 4 of 7

## ROOF CURB INSTALLATION INSTRUCTIONS:



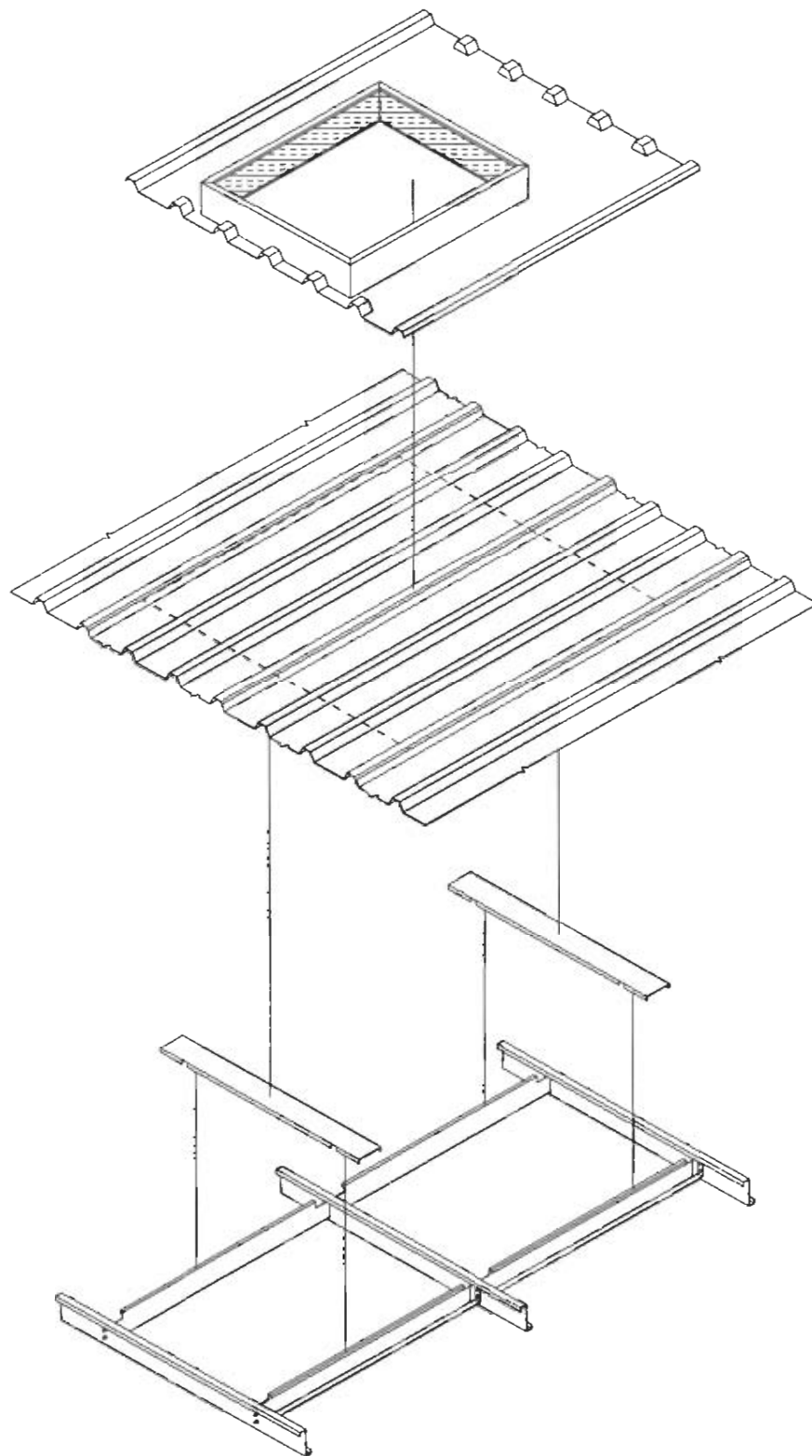





### R-PANELS



### Installation Check List:

- \_\_\_ Attach Sub-frame(s) ..... Step 1
- \_\_\_ Layout Curb(s) on Roof Panel ..... Step 2
- \_\_\_ Mount Back-up Channels ..... Step 3
- \_\_\_ Apply Sealants & Set Curb in Place ..... Step 4
- \_\_\_ Fasten Curb to Back-up Channels ..... Step 5

### PARTS LIST

	<u>Flat Washer</u>		<u>Polyurethane Sealant Caulk</u>
	<u>Nut</u>		<u>14 Gauge Galvanized Steel Subframe</u> 5-1/2" tall Length is equal to the purlin spacing minus 1-3/8"
	<u>3/8" x 1" bolts</u>		<u>Back-up Channel</u>
	<u>#14 - 1 1/8" Neoprene Self-Tap Screw</u>		
	<u>Triple Bead Sealant Tape</u>		

## BEGIN INSTALLATION

### ① ATTACH SUB-FRAMES

Attach sub-frames to purlins (see drawing 1.1 and 1.2). Finger tighten all hardware, then upset threads to secure nuts. Attach sub-frames using the nuts, bolts, and washers.

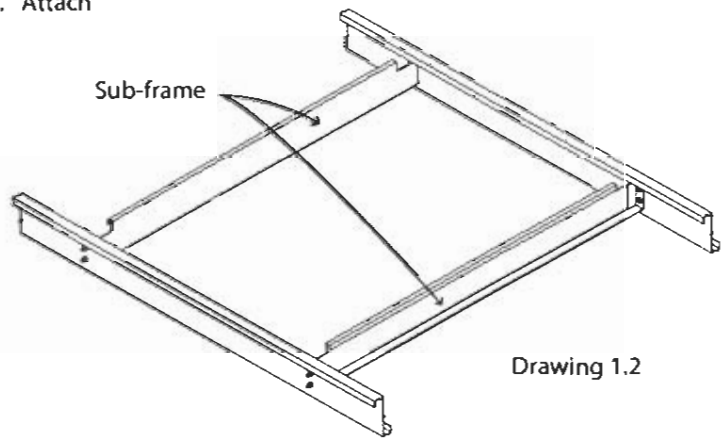
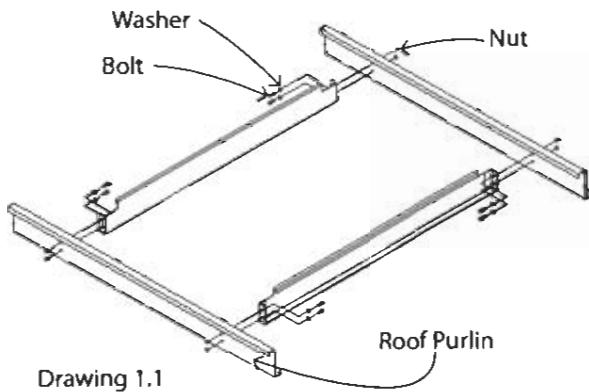

**\*NOTICE\*** Sub-frame max. loading 500 lbs.

**WARNING!**  
ALWAYS USE FALL PROTECTION WHILE  
WORKING AROUND ROOF OPENINGS

### ② LAYOUT CURB ON ROOF PANEL

Mark base flange locations and throat area cut lines by setting roof curb in place on roof panel (DO NOT USE LEAD PENCIL). Upslope/downslope cut lines will be 2 1/2" less than outer edge of base flange.

**Note #1:** For uninsulated curb(s), throat opening is actual I.D. of curb. For insulated curb(s), use actual I.D. and add 1 3/4" to each side.

Cut Line will be 2 1/2" less than outer edge of upslope/downslope curb base flange.

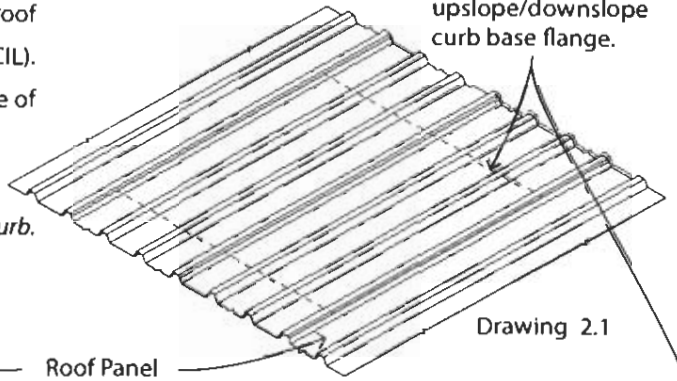

Drawing 2.1

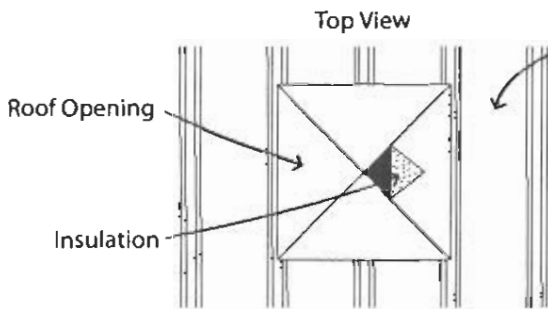

Drawing 2.2

Remove Insulation leaving insulation facing in place. Cut insulation facing diagonally and tuck sections under roof panels to trim roof openings.

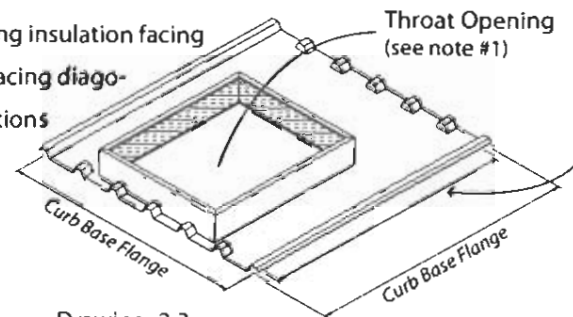

Drawing 2.3

\*Notice\* Sub-frames and back-up channels not shown in the above picture.

### ③ MOUNT BACK-UP CHANNELS

Center back-up channels with the center roof opening(s). Cut slots in back-up channels to slide over sub-frame(s) (see drawing 4.1).

Back-up channels are not be screwed to sub-frame or purlin. Slide back-up channels underneath roof panel (see drawing 4.2). Back-up channels are to be flush with roof opening as showing in drawing 4.2.

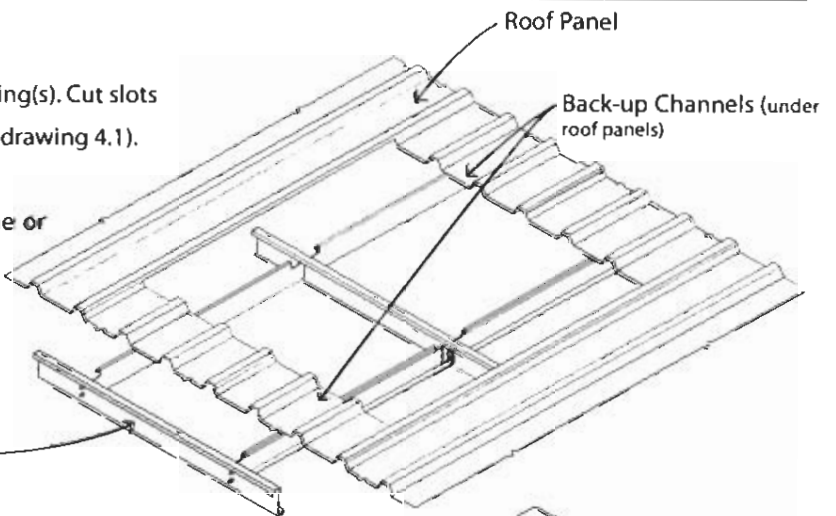

DRAWING 4.2

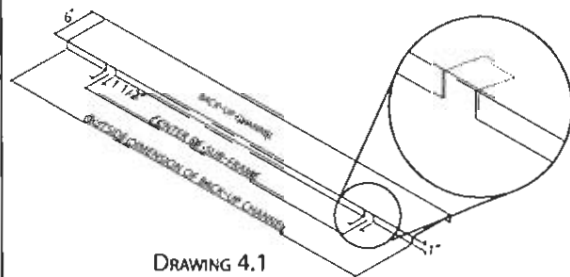

DRAWING 4.1

Fold cut tabs up 90 degrees underneath the back-up channels as shown.

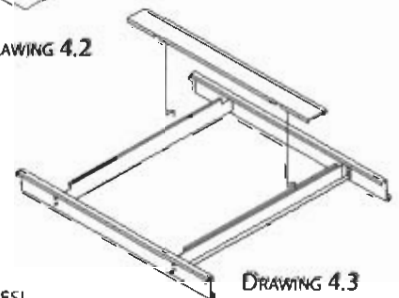

DRAWING 4.3

\*NOTICE\* DO NOT SCREW BACK-UP CHANNELS TO SUB-FRAMES!

**WARNING!**  
ALWAYS USE FALL PROTECTION WHILE WORKING AROUND ROOF OPENINGS.

### ④ APPLY SEALANTS & SET CURB IN PLACE

Apply a strip of sealant tape on the upslope side of the roof curb(s) and on downslope side of the roof panel before setting roof curb(s) in place (see drawing 4.1).

The downslope highs are to be installed **OVER** the roof panel.

The upslope highs are to be installed **UNDER** the roof panel.

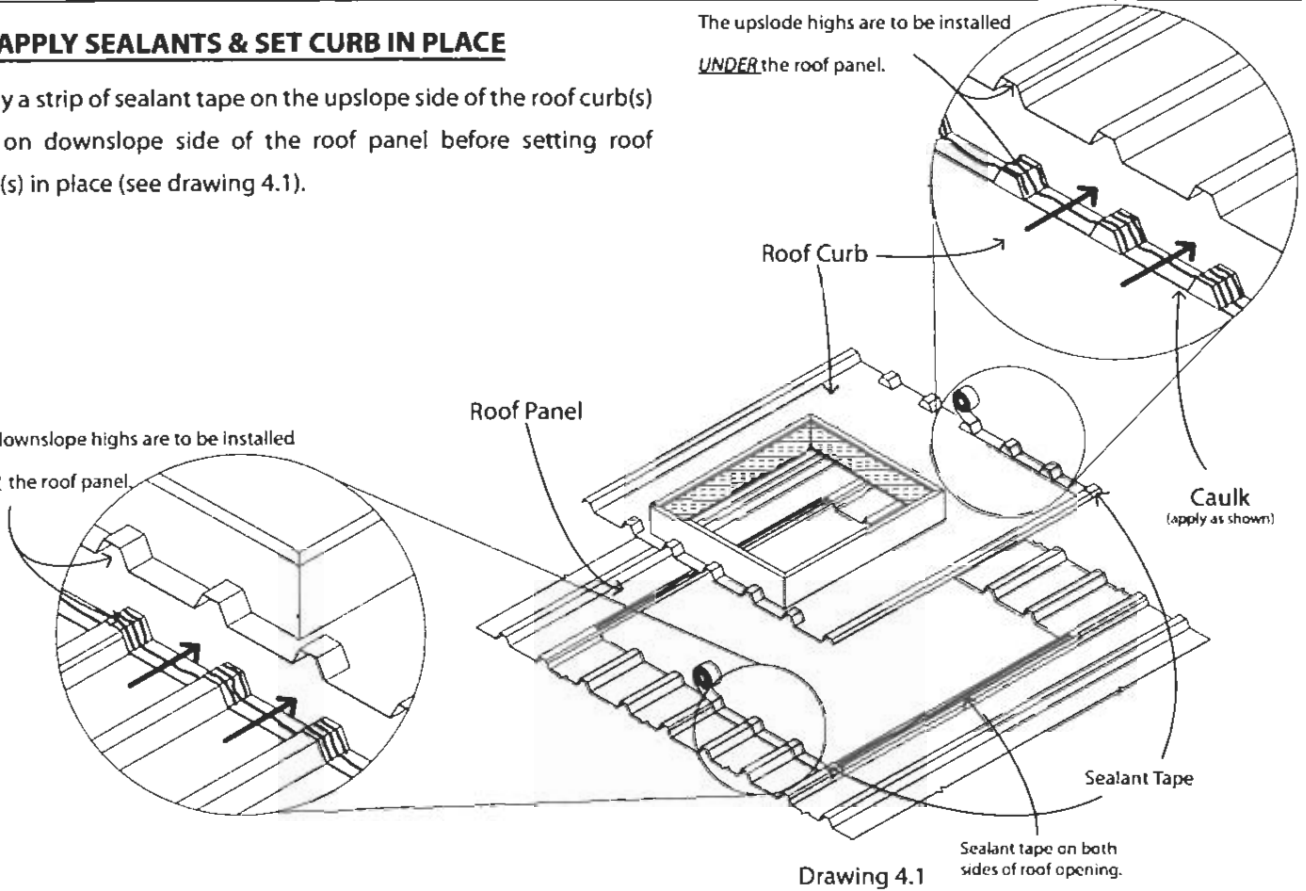

Drawing 4.1

\*NOTICE\* Sub-frames and back-up channels not shown in the above picture(s).

### ⑤ FASTEN CURB TO BACK-UP CHANNELS

Fasten curb(s) to back-up channels and roof panel using self-tap screws (see drawing 5.2). DO NOT FASTEN CURB, ROOF PANEL, OR BACK-UP CHANNELS TO SUB-FRAMES.

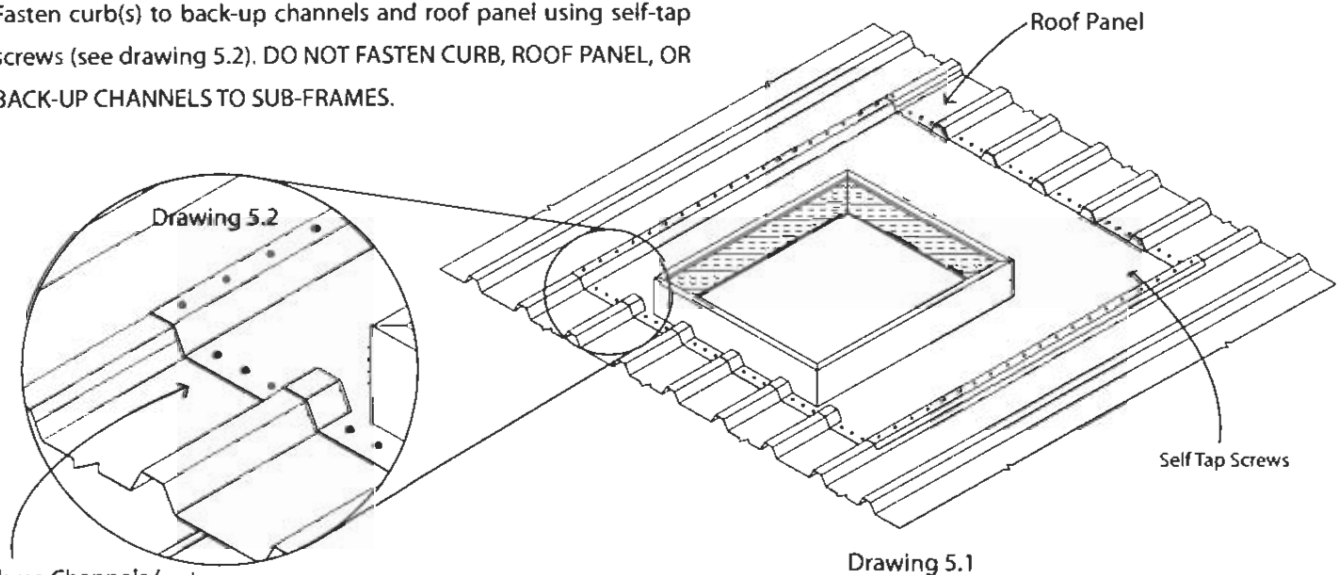

Drawing 5.1

Back-up Channels (under roof panels)

\*NOTICE\* Sub-frames and back-up channels not shown in the above picture(s).

**WARNING!**  
ALWAYS USE FALL PROTECTION WHILE WORKING AROUND ROOF OPENINGS.

## COMPLETED INSTALLATION

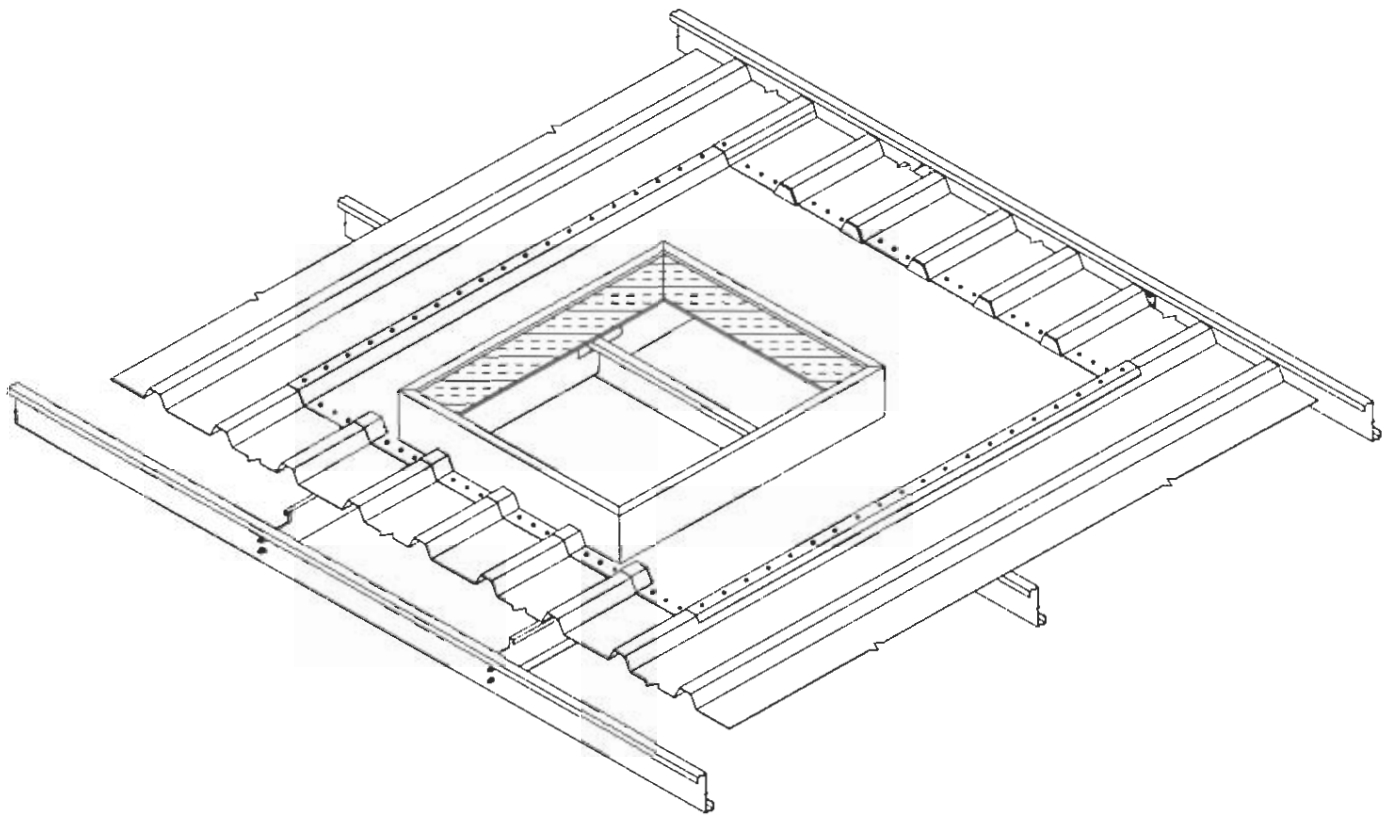

**WARNING!**  
ALWAYS USE FALL PROTECTION WHILE  
WORKING AROUND ROOF OPENINGS