

CHANGE OF OCCUPANCY FOR:

LITTLE FEET FIRST

659 OLD SPANISH TRAIL, SLIDELL, LA 70458

PROJECT DATA:

OCCUPANCY:
IBC 2015 - E - EDUCATIONAL
(PREVIOUSLY BUSINESS OCCUPANCY)
NFPA 101 - CHILD DAY CARE OCCUPANCY
BUILDING AREA: 2,700 SF
CONST. TYPE: VB (9,000SF MAX AREA PER FLOOR)
IBC 2015. 308.6.1 CLASSIFICATION AS GROUP E. A CHILD DAY CARE FACILITY THAT PROVIDES CARE FOR MORE THAN 5 BUT NO MORE THAN 100 CHILDREN 2 1/2 YEARS OR LESS OF AGE, WHERE THE ROOMS IN WHICH THE CHILDREN ARE CARED FOR ARE LOCATED ON A LEVEL OF EXIT DISCHARGE SERVING SUCH ROOMS AND EACH OF THESE CHILD CARE ROOMS HAS AN EXIT DOOR DIRECTLY TO THE EXTERIOR, SHALL BE CLASSIFIED AS GROUP E.

FIRE PROTECTION:
BUILDING SPRINKLER: NONE REQUIRED WHEN FIRE AREA IN EDUCATIONAL (E) OCCUPANCY IS LESS THAN 12,000 SF.

BUILDING FIRE ALARM: FIRE ALARM SYSTEM IN ACCORDANCE WITH NFPA 72 IS REQUIRED.

ALTERATION - LEVEL 2

LEVEL 2 ALTERATIONS INCLUDE THE RECONFIGURATION OF SPACE, THE ADDITION OR ELIMINATION OF ANY DOOR OR WINDOW, THE RECONFIGURATION OR EXTENSION OF ANY SYSTEM, OR THE INSTALLATION OF ANY ADDITIONAL EQUIPMENT. (AND WHERE THE WORK AREA IS LESS THAN 50 PERCENT OF THE AGGREGATE AREA OF THE BUILDING.)

701.3 COMPLIANCE

ALL **NEW** CONSTRUCTION ELEMENTS, COMPONENTS, SYSTEMS, AND SPACES SHALL COMPLY WITH THE REQUIREMENTS OF THE **INTERNATIONAL BUILDING CODE**.

PROJECT DATA:

ZONING CLASSIFICATION: C - COMMERCIAL

OCCUPANCY: E - EDUCATIONAL

TOTAL OCCUPANTS 2,700 SF / 50 = 54 OCC.

NO. OF EXITS REQUIRED 2
NO. OF EXITS PROVIDED 4

PARKING SPACES REQUIRED:

DAY CARE 2,700 SF 1:350 = 9 SPACES

PARKING SPACES PROVIDED:

14 PARKING SPACES

PERVIOUS/ IMPERVIOUS:

MAX. IMPERVIOUS AREA = 75%
TOTAL SITE AREA = 16,743 SF
IMPERVIOUS AREA PROVIDED, 11,806.5 SF = 70.52%
PERVIOUS AREA PROVIDED, 4,936.5 SF = 29.48%

SIGNAGE: BY SEPARATE PERMIT

INDEX OF DRAWINGS:

COVER	INDEX, STRUCTURAL DATA, PROJECT DATA
A1.0	SITE PLAN, BUILDING SPRINKLER INFORMATION
A2.0	EXISTING & PROPOSED FLOOR PLANS

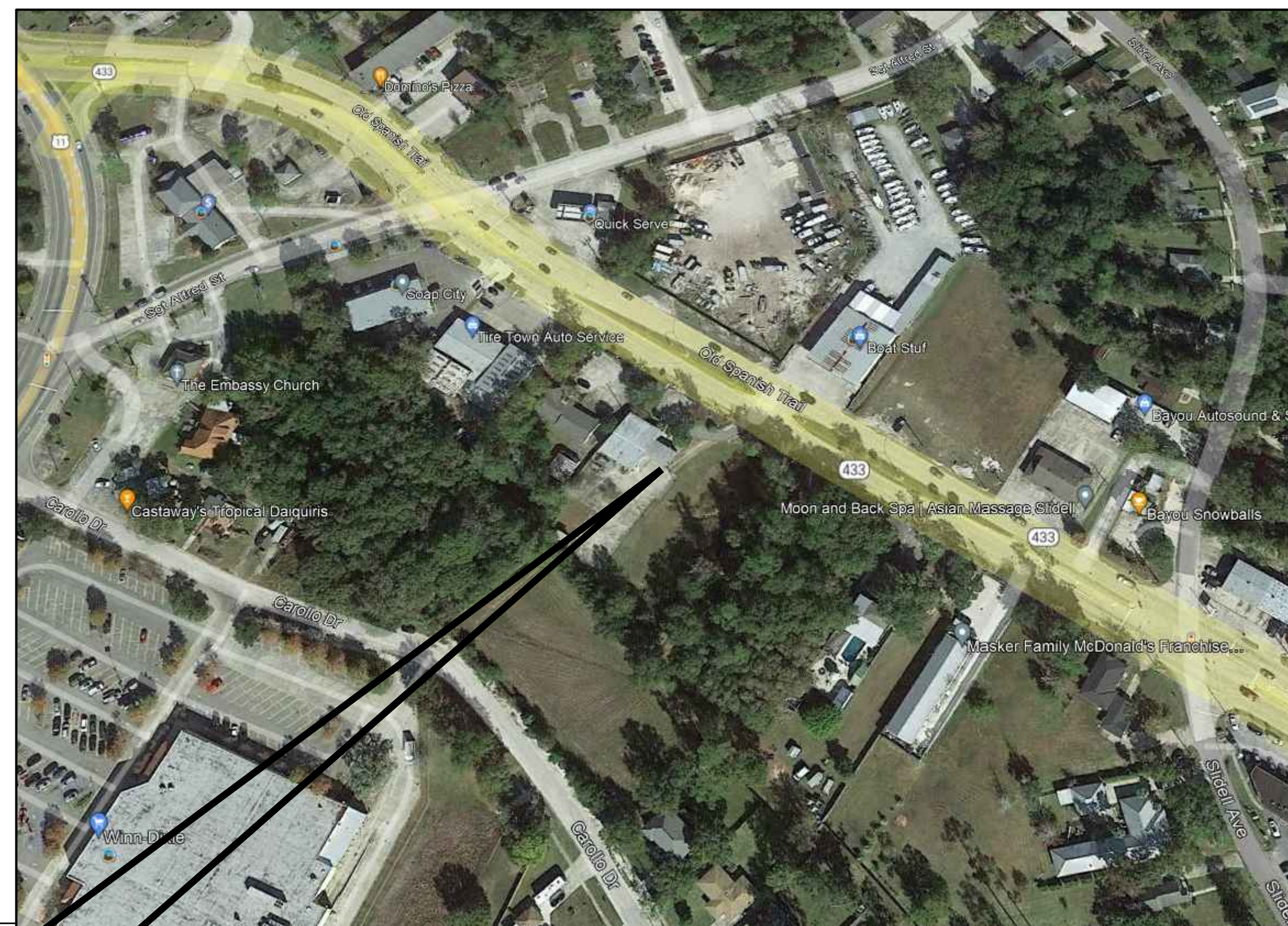

SITE

VICINITY MAP
N.T.S.

SELECTIVE DEMOLITION NOTES:

CONTRACTOR SHALL VISIT SITE AND VERIFY CONDITIONS PRIOR TO SUBMITTING BID. CONTRACTOR SHALL ADVISE ARCHITECT IF EXISTING CONDITIONS ARE IN CONFLICT WITH THESE DOCUMENTS.

CONTRACTOR TO DISPOSE OF ALL CONSTRUCTION DEBRIS OFF-SITE IN ACCORDANCE WITH APPLICABLE LOCAL CODES AND LA DEQ.

ITEMS INDICATED TO BE SALVAGED OR REUSED SHALL BE PROTECTED AND STORED ON-SITE.

SEQUENCE DEMOLITION WORK STARTING AT HIGHER AREAS AND FINISHING AT LOWER AREAS, OR AS PRACTICAL BASED ON FIELD CONDITIONS.

MAINTAIN EXISTING WALKWAYS, EXITS, AND OTHER FACILITIES USED BY OCCUPANTS OF ADJACENT AREAS IN A SAFE MANNER.

HAZARDOUS MATERIALS ARE NOT EXPECTED TO BE ENCOUNTERED IN THE WORK. IF MATERIALS ARE SUSPECTED OF BEING OF HAZARDOUS CONTENT, DO NOT DISRUPT. IMMEDIATELY NOTIFY THE ARCHITECT AND OWNER.

DEMOLITION CONTRACTOR IS RESPONSIBLE FOR TEMPORARY SHORING OF FACILITIES TO BE DEMOLISHED AND STRUCTURES ADJACENT TO THE DEMOLITION.

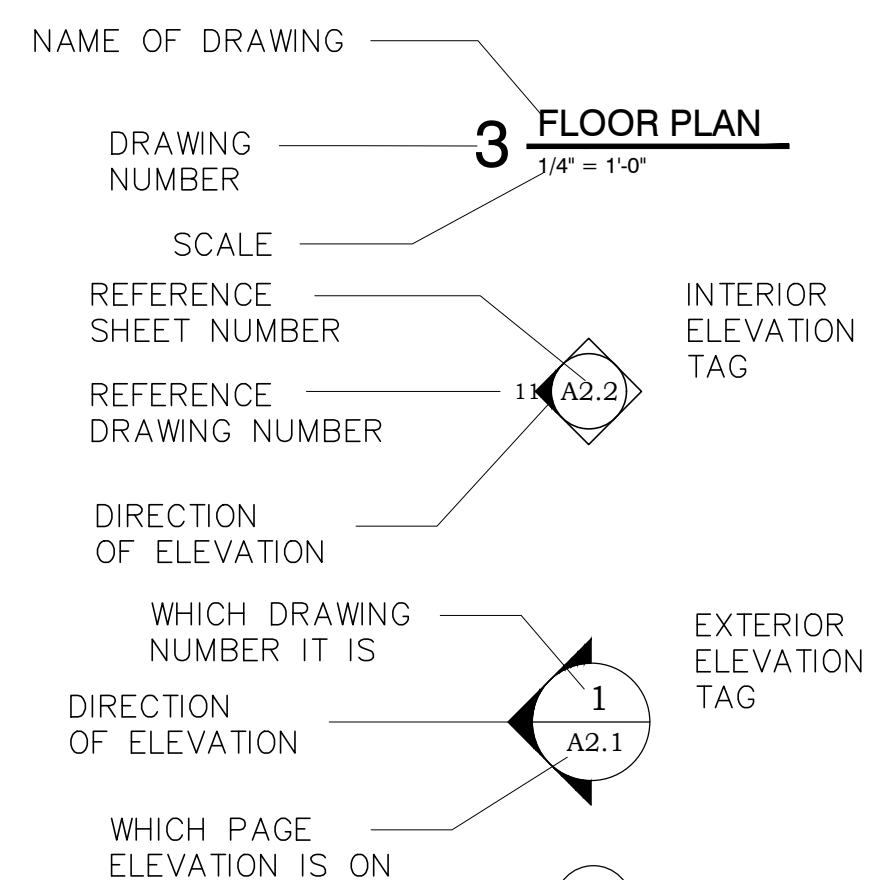

STANDARD NOTING:

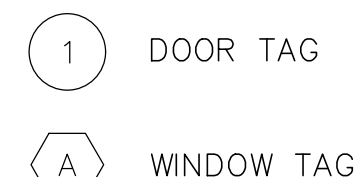

KVS
architecture
235 Girod Street, Mandeville, Louisiana
985.674.3077 www.kvsarchitecture.com

8.1.22



THESE DRAWINGS HAVE BEEN PREPARED BY ME OR UNDER MY DIRECT SUPERVISION, AND TO MY KNOWLEDGE, COMPLY WITH ALL LOCAL, STATE, AND FEDERAL REQUIREMENTS.

K. VAUGHAN SOLLBERGER, JR., LA# 5523

CHANGE OF OCCUPANCY FOR:

LITTLE FEET FIRST

659 OLD SPANISH TRAIL, SLIDELL, LA 70458

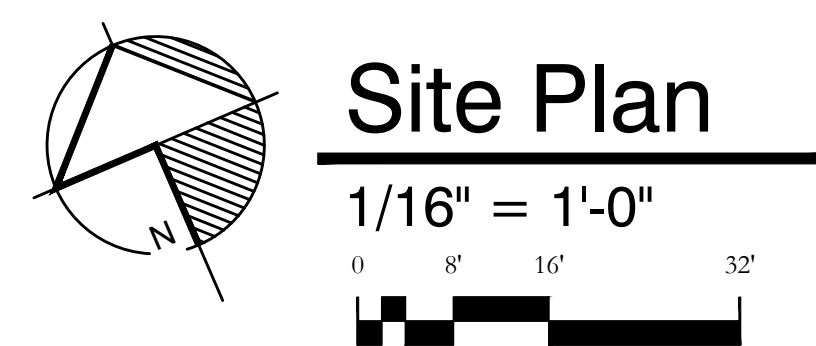
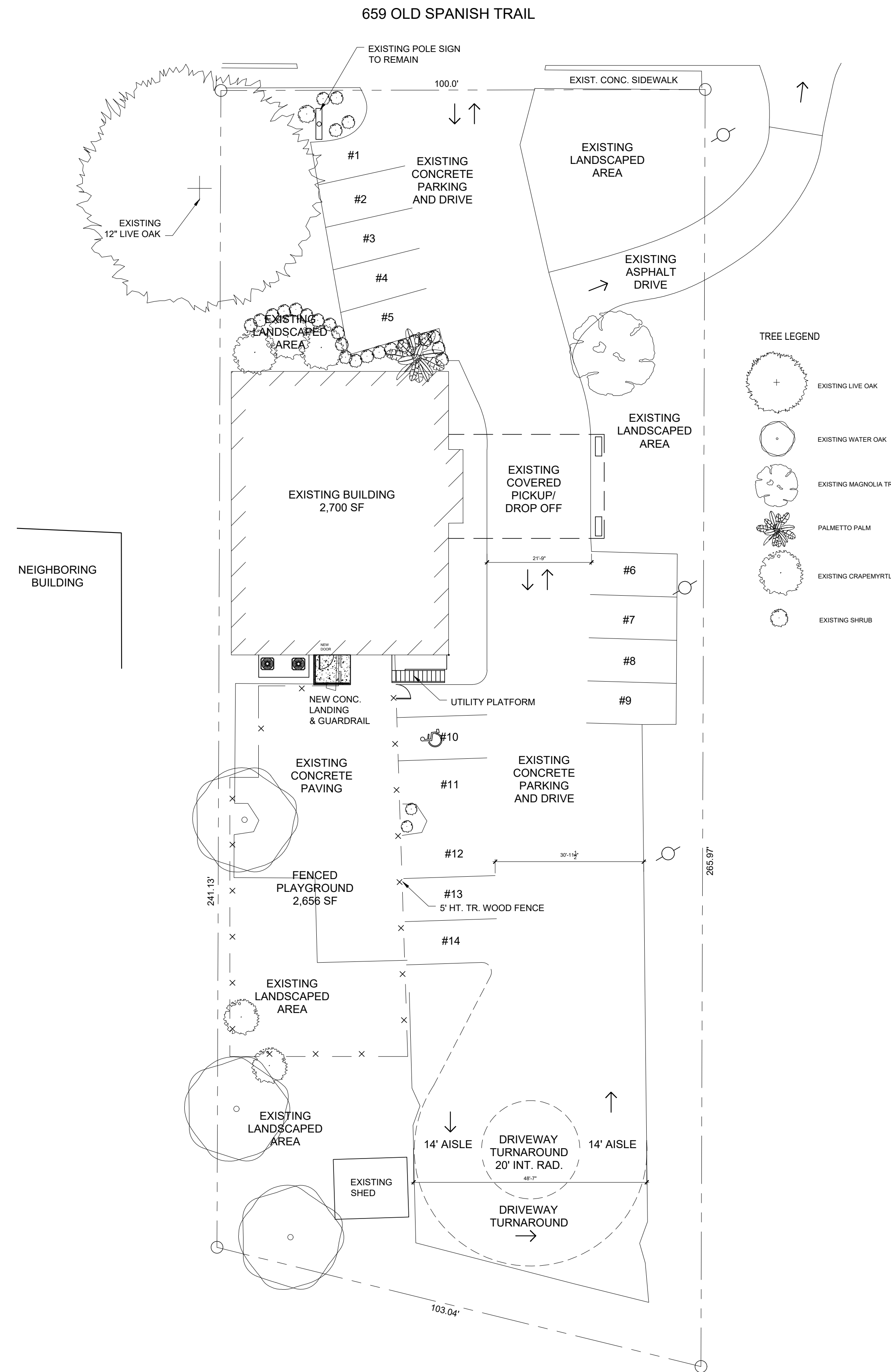

ELECTRICAL NOTES:

1. MINOR ELECTRICAL WORK FOR THIS PROJECT INCLUDES REPLACEMENT OF LIGHTING FIXTURES, AND RELOCATION OF SELECT ELECTRICAL OUTLETS AND DEVICES. EXISTING ELECTRICAL SERVICE TO BUILDING TO REMAIN.
2. ALL ELECTRICAL WORK SHALL BE PERFORMED BY A LICENSED ELECTRICIAN.
3. ELECTRICAL WORK SHALL COMPLY WITH NFPA 70 (2015), NATIONAL ELECTRICAL CODE.
4. GROUNDING SHALL CONFORM TO ARTICLE 250 OR THE NEC.
5. ELECTRICAL WORK IN WET AREAS SHALL COMPLY WITH NFPA 70: ARTICLE 680.
6. ELECTRICAL CONTRACTOR TO BE RESPONSIBLE FOR THE SIZING AND FUNCTIONING OF THE PANELS AND ALL WIRING, SWITCHES, FIXTURES, ETC.
7. BATHROOM RECEPTACLES SHALL HAVE GFCI PROTECTION.
8. OUTDOOR RECEPTACLES SHALL HAVE GFCI PROTECTION.

MECHANICAL NOTES:

1. EXISTING HVAC EQUIPMENT DUCTS AND SERVICES ARE TO REMAIN - NO WORK.

PLUMBING NOTES:

1. MINOR PLUMBING WORK FOR THIS PROJECT INCLUDES THE REPLACEMENT OF TWO PLUMBING FIXTURES (A TOILET & KITCHEN SINK) THE ADDITION OF A THREE COMPARTMENT SINK WITH GREASE INTERCEPTOR, A NEW HANDSINK, AND MAINTENANCE OF OTHER AREAS OF PIPING.
2. ALL WORK AND MATERIAL SHALL CONFORM TO THE LATEST GOVERNING CODES. VERIFY ALL EXISTING CONDITIONS IN FIELD PRIOR TO COMMENCING WORK. CONTRACTOR TO PAY ALL FEES ASSOCIATED WITH PLUMBING WORK AND TIE-INS.
3. COORDINATE THE ROUTING AND LOCATIONS OF PLUMBING PIPING AND EQUIPMENT WITH ALL OTHER TRADES PRIOR TO INSTALLATION.
4. VERIFY SYSTEM REQUIREMENTS ESTABLISHED BY GENERAL CONTRACTOR AND OWNER REGARDING UTILITIES TO EQUIPMENT AND FIXTURES SUPPLIED BY OTHERS AND PROVIDE NECESSARY COMPONENTS FOR PROPER INSTALLATION.

GREASE INTERCEPTOR NOTES:

1. PROVIDE CLEANOUTS BEFORE AND AFTER GREASE INTERCEPTOR.
2. WALLS, TOP AND BOTTOM SHALL BE ACCESSIBLE FOR CLEANING AND MAINTENANCE.
3. PRECAST HDP UNIT MAY BE INSTALLED, PROVIDED THAT IT IS CONSTRUCTED IN ACCORDANCE WITH ALL APPLICABLE CODES.
4. PROVIDE BAFFLES IF REQUIRED BY LOCAL CODES.
5. FIELD VERIFY EXACT LOCATION FOR GREASE TRAPS AND COORDINATE THEIR INSTALLATION WITH OTHER UTILITIES.
6. CAPACITY: 8 POUNDS @ 4 GPM.

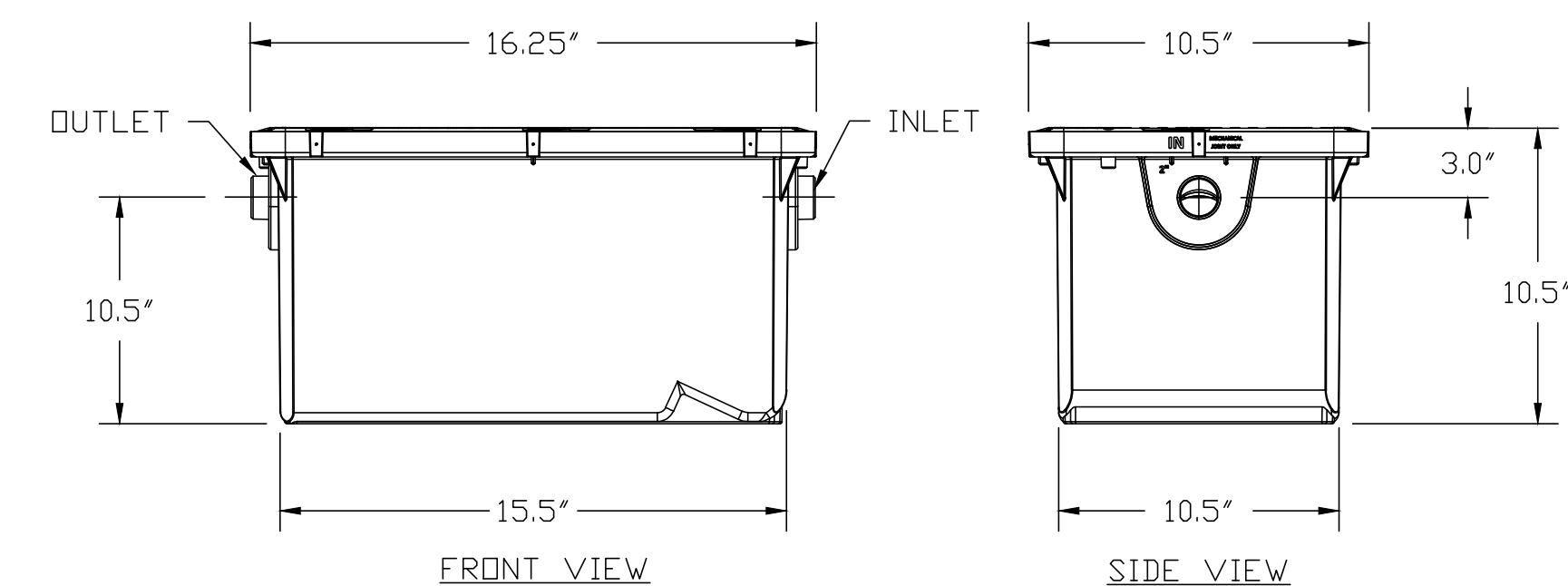
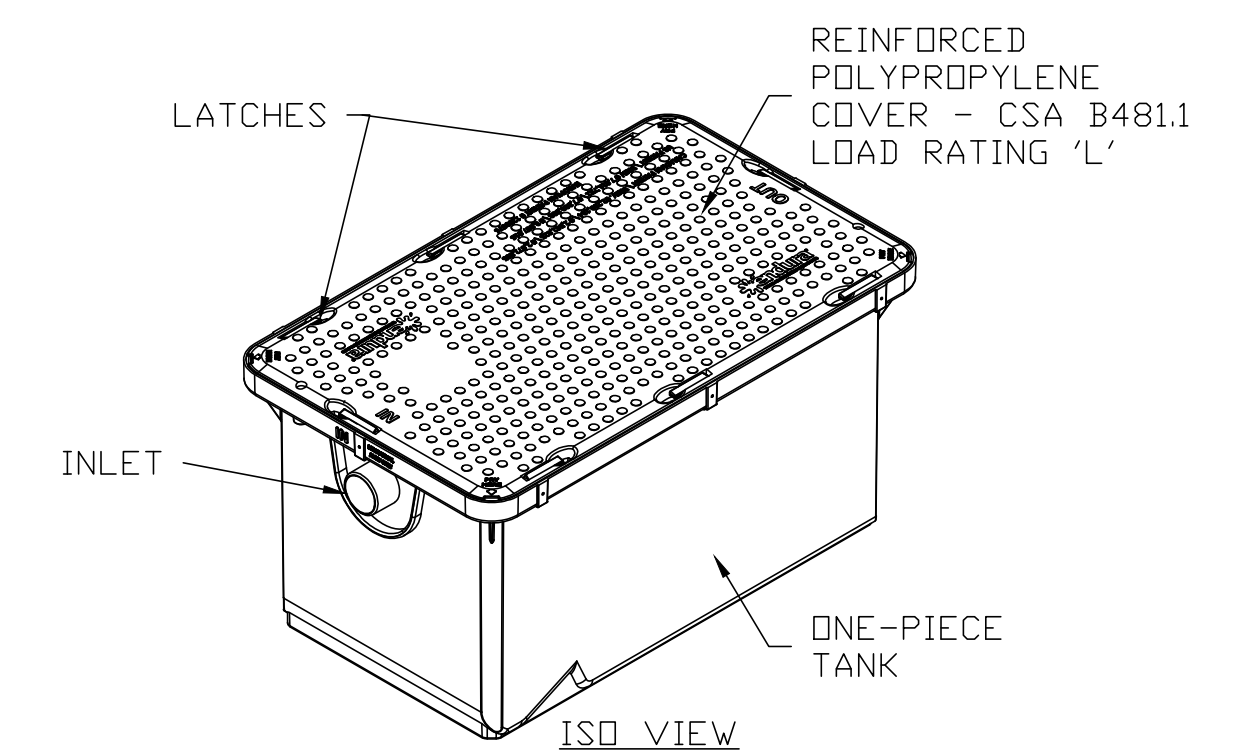

KVS architecture

235 Girod Street, Mandeville, Louisiana
985.674.3077 www.kvsarchitecture.com

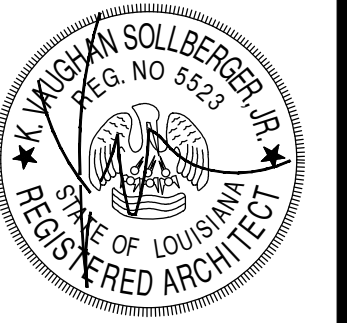

CHANGE OF OCCUPANCY FOR:

LITTLE FEET FIRST-DAY CARE

659 OLD SPANISH TRAIL, SLIDELL, LA 70458

REVISIONS:

DATE: 8.01.22

PROJECT No: 21040

DRAWING:

A1.0

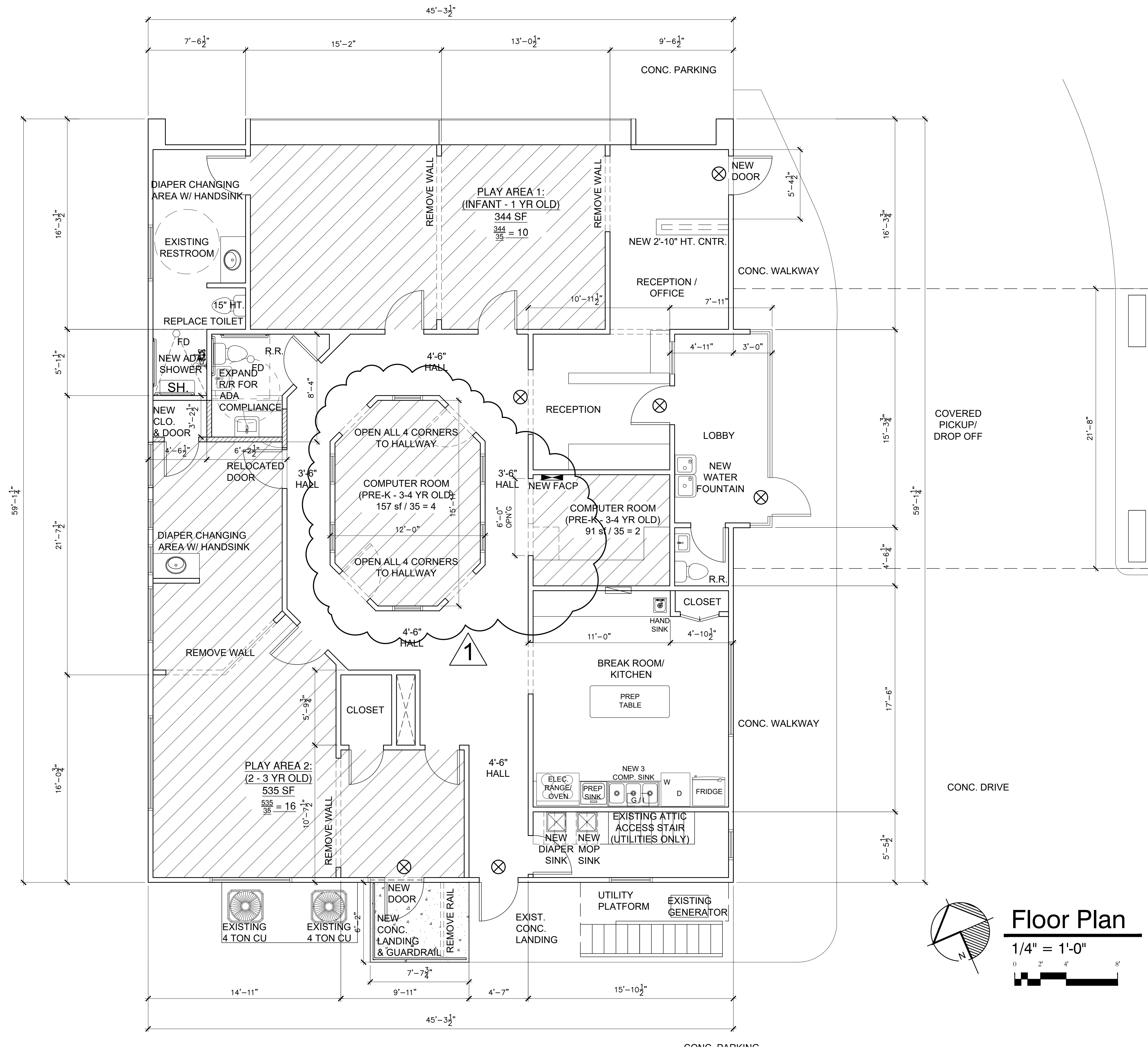

SCOPE OF WORK:

⊗ WHITE THERMOPLASTIC, ILLUMINATED EXIT SIGN W/ RED LETTERING AND EMERGENCY LIGHT ON BATTERY BACKUP

NEW DOOR NEW DOOR TO BE 3'-0" X 6'-8" SOLID CORE WOOD DOOR W/ LEVER HANDLE LATCHSET HDWR. & CYLINDER LOCK WITH THUMBLATCH

NEW FACP NEW FIRE ALARM CONTROL PANEL AND SYSTEM IN ACCORDANCE WITH NFPA 72 TO BE SUBMITTED SEPARATELY FOR REVIEW BY STATE FIRE MARSHAL.

GENERAL: EXISTING BATHROOM DOOR LOCKS TO BE REPLACED WITH LOCKS THAT PERMIT OPENING FROM THE OUTSIDE IN AN EMERGENCY.

2015 LA PLUMBING CODE AMENDMENTS:

403.6 Other Fixture Requirements for Licensed Pre-Schools, Day Care Centers, and Residential Facilities

Additional plumbing fixtures shall be provided in day care centers and residential facilities as required by this Section.

403.6.1 Food Preparation

The food preparation area in pre-schools, day cares, and residential facilities shall meet the following requirements. The food preparation, storage and handling where six or less individuals are cared for shall provide a two-compartment sink and an approved domestic type dishwasher. Where the number of individuals cared for is between 7 and 15, either a three-compartment sink, or an approved domestic or commercial type dishwashing machine and a two-compartment sink with hot and cold running water shall be provided. Where 16 or more individuals are cared for, a three-compartment sink must be provided. If a dishwasher is also utilized in these instances (16 or more individuals), it must be a commercial type and it shall be in addition to the required three-compartment sink. One laundry tray, service sink, or curbed cleaning facility with floor drain shall also be provided on the premises for cleaning of mops and mop water disposal (for facilities caring for 16 or more individuals).

403.6.2 Caring for Children Between 0 and 4 Years of Age

In child day care facilities, a hand washing sink shall be in or adjacent to each diaper changing area. In addition, one extra laundry tray, service sink, or similar fixture is required to clean and sanitize toilet training potties immediately after each use. Such fixture shall be dedicated solely for this purpose and shall not be in the food preparation/storage, utensil washing, or dining areas. Training potties shall not be counted as toilets in determining the minimum fixture requirements of Table 403.1. Fixtures shall be size appropriate for the age of the children being cared for (toilets 11 inches maximum height and lavatories 22 inches maximum height), or if standard size fixtures are used, safe, cleanable step aids shall be provided.

Floor Plan

1/4" = 1'-0"
0 2' 4' 8'

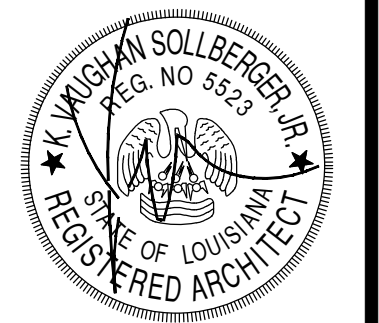

CHANGE OF OCCUPANCY FOR:
LITTLE FEET FIRST-DAY CARE
659 OLD SPANISH TRAIL, SLIDELL, LA 70458

REVISIONS:
▲ 9.27.22
DATE:
8.01.22
PROJECT No:
21040
DRAWING:

A2.0