

THESE DRAWINGS WERE PREVIOUSLY SIGNED AND SEALED ON FEBRUARY 19, 2010 BY SHAWN J. FRANKE P.E. LOUISIANA REG. NO. 28077

**THE SAENGER THEATRE RENEWAL PROJECT**

142 North Rampart Street  
New Orleans, LA

Client  
Saenger Theatre Redevelopment Company  
200 West Loop South, Suite 1040  
Houston, TX 77027

Architect  
**MARTINEZ+JOHNSON**  
ARCHITECTURE

1412 Eye St., NW  
Washington, DC 20005  
202.333.4480

Structural Engineer  
Shawn J. Franke, P.E.  
549 Helmer Road  
San Antonio, TX 78232  
210.979.7900

Theatre Consultant  
Schuler Shaok  
123 Third Street North #210  
Minneapolis, MN 55401  
612.339.5958

Acoustical Engineer  
Akustiks

93 North Main Street South  
Norwalk, CT 06854  
202.299.1904

MEP Engineer  
JBA Consulting Engineers, Inc.  
3525 N. Causeway Blvd., Suite 500  
Metairie, LA 70002  
202.393.1199

Architectural Historian  
EHT Traceries, Inc.  
1121 Fifth Street NW  
Washington, DC 20001  
202.393.1199

THESE DRAWINGS, SPECIFICATIONS, AND OTHER DOCUMENTS (COLLECTIVELY, THE "DOCUMENTS") INCLUDING WITHOUT LIMITATION ELECTRONIC VERSIONS THEREOF AND THE IDEAS, DESIGNS, AND ARRANGEMENTS REPRESENTED THEREBY ARE AND SHALL REMAIN THE PROPERTY OF MARTINEZ & JOHNSON ARCHITECTURE P.C. AS DEFINED BY APPLICABLE CONTRACTUAL AGREEMENTS (THE "AGREEMENTS") AND AS PROTECTED BY THE COPYRIGHT STATUTES OF THE UNITED STATES. USE OF THE DOCUMENTS SHALL BE STRICTLY LIMITED TO THE PROJECT FOR WHICH THEY WERE PREPARED AND DEVELOPED (THE "PROJECT") PER THE TERMS OF THE AGREEMENTS. NO PART OF THE DOCUMENTS SHALL BE COPIED, DISCLOSED TO OTHERS, OR USED IN CONNECTION WITH ANY OTHER WORK OR PROJECT, OR BY ANY OTHER PERSONS FOR ANY PURPOSES, OTHER THAN THE COMPLETION OF THE PROJECT WITHOUT THE SPECIFIC WRITTEN AUTHORIZATION OF MARTINEZ & JOHNSON ARCHITECTURE P.C. THE DOWNLOADING, OPENING, OR VIEWING OF ELECTRONIC VERSIONS OF THE DOCUMENTS OR VISUAL CONTACT WITH ANY PRINTED FORM THEREOF SHALL CONSTITUTE CONCLUSIVE EVIDENCE OF ACCEPTANCE OF THESE RESTRICTIONS.

7502

DATE:	No.:	REVISION:
09.15.10	1	ELECTRICAL VAULT FOR CONSTRUCTION

DATE:	ISSUE:
02.19.10	PERMIT SET
04.02.10	GMP
11.11.10	CONTRACT SET

SHEET TITLE:  
**SECTIONS**

**S-4.24**

SECTIONS As indicated 1

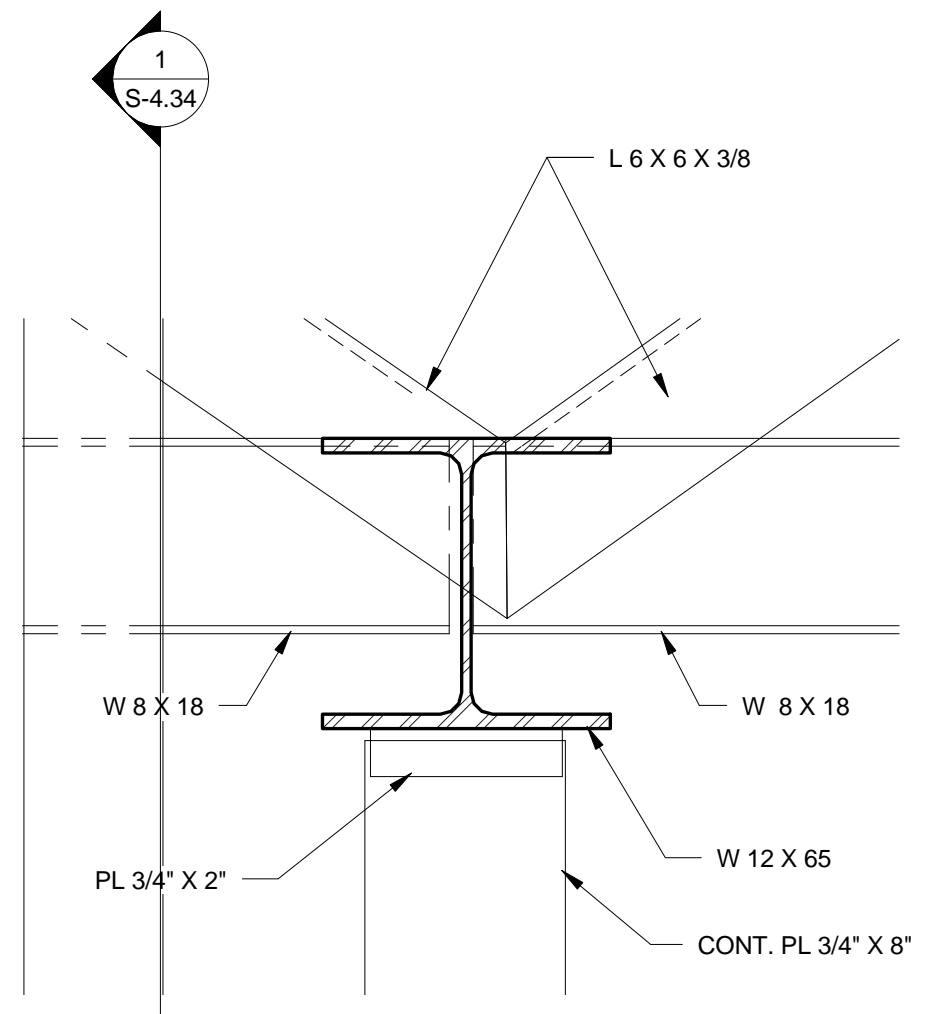

**4** DETAIL  
1 1/2" = 1'-0"

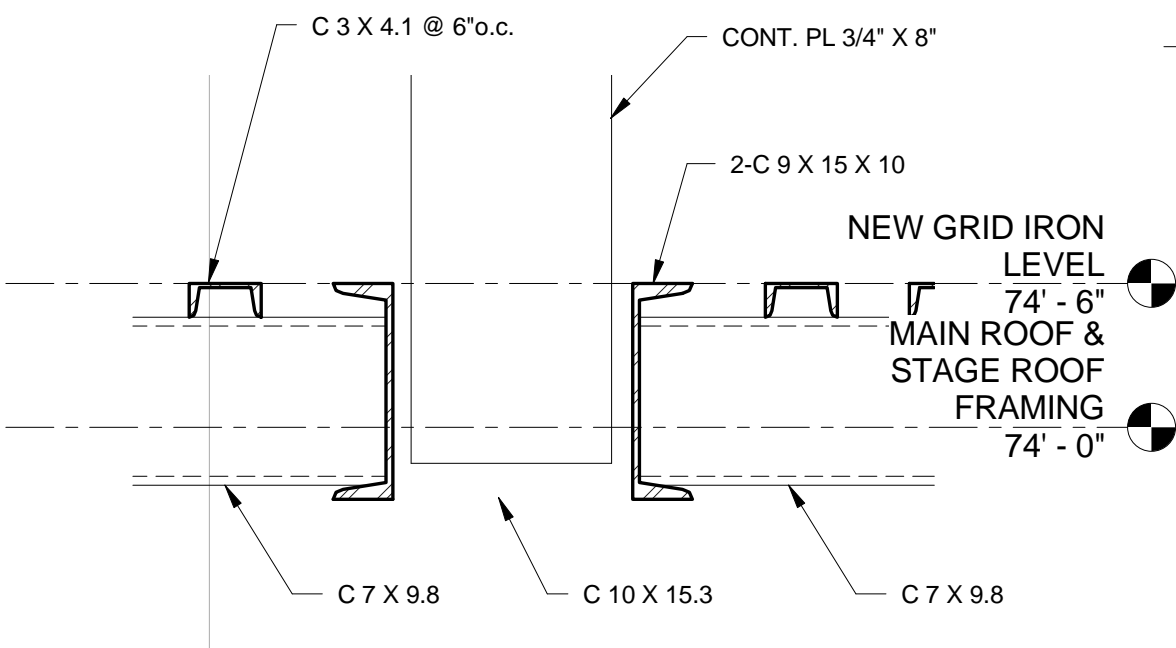

**5** DETAIL  
1 1/2" = 1'-0"

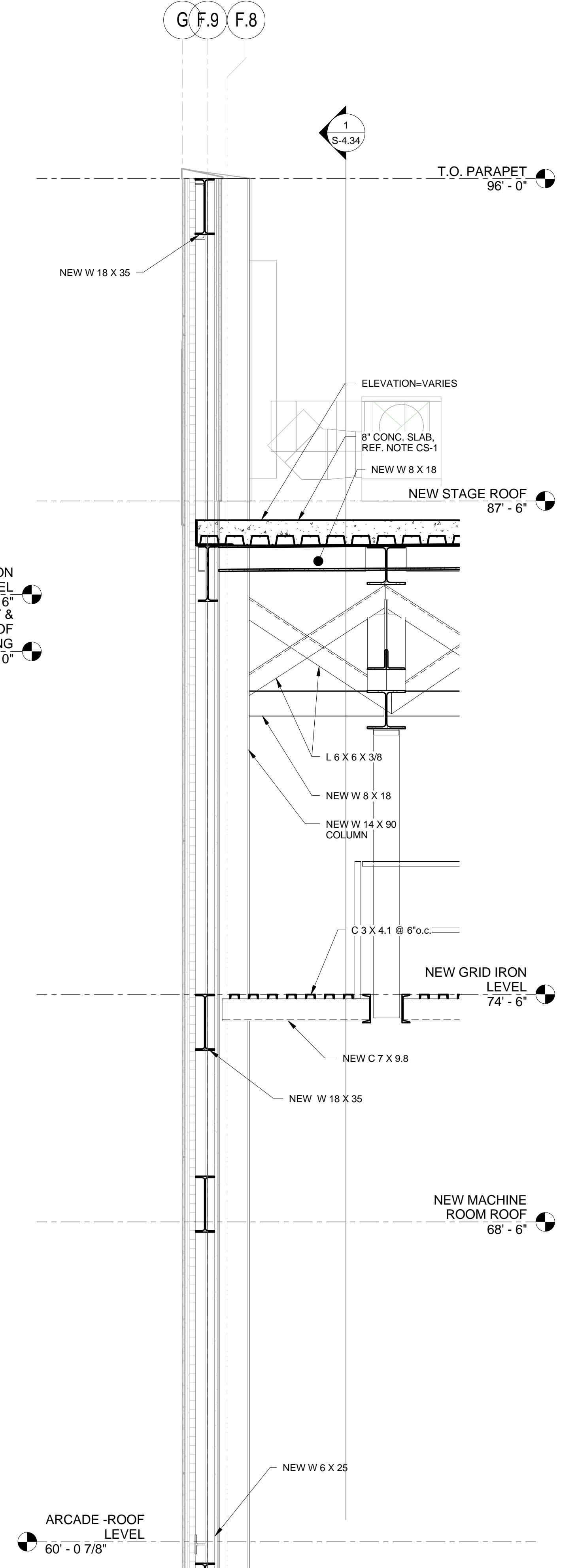

**3** SECTION  
1/2" = 1'-0"

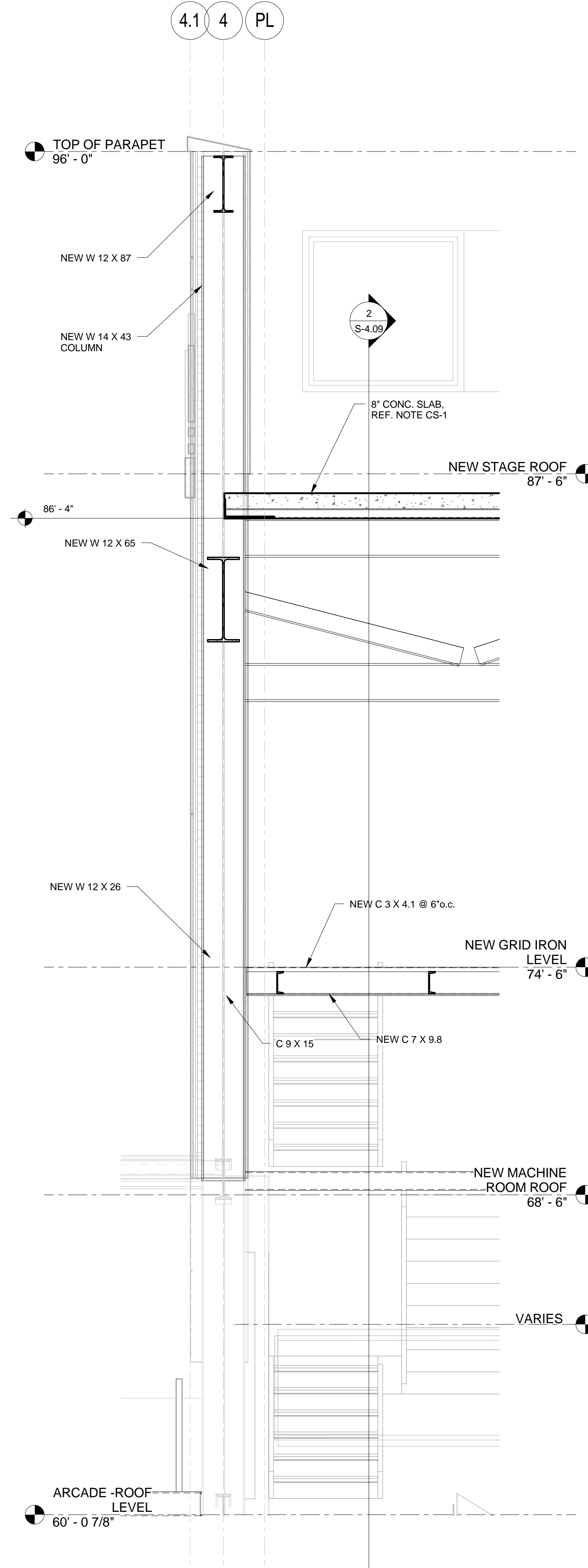

**2** SECTION  
1/2" = 1'-0"

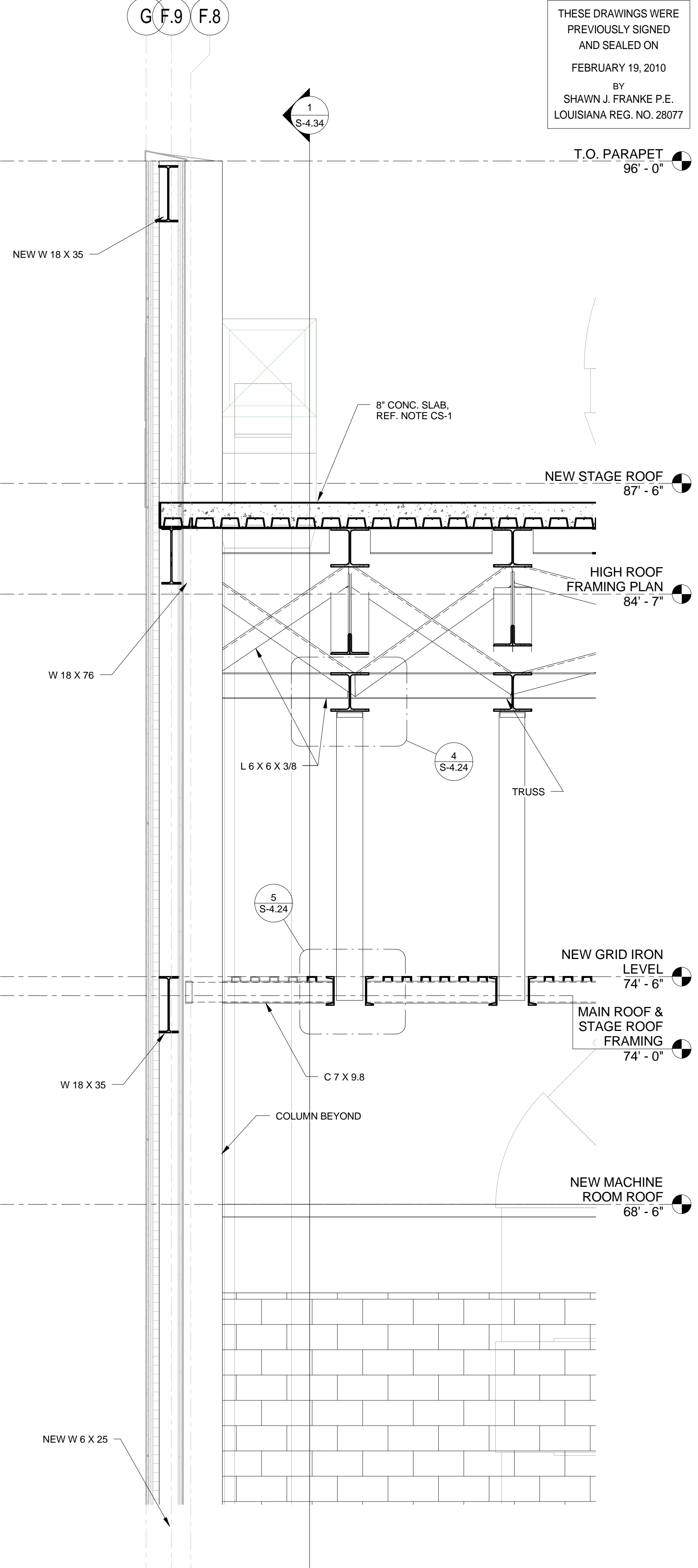

**1** SECTION  
1/2" = 1'-0"