

SPECIFIC NOTES:

- 1 TRANSFORMER SHALL BE 480 VOLT DELTA PRIMARY TO 208Y/120 VOLT SECONDARY.
- 2 PROVIDE INTEGRAL TVSS INSIDE MAIN DISTRIBUTION BOARD. TVSS SHALL HAVE SURGE CURRENT RATING OF 240 KA PER PHASE AND HAVE INTERRUPT RATING OF 200 KAIR. THE TVSS SHALL EMPLOY A HYBRID DESIGN IN WHICH IN ADDITION TO THE MOV'S IT ALSO HAS A PARALLEL CAPACITIVE FILTER. IT SHALL HAVE A AUDIBLE ALARM (AND SILENCE SWITCH) THAT IS ACTIVATED ON FAILURE OF A MODULE. IT SHALL ALSO COME WITH A NO/NC CONTACT TO INDICATE THE FAILURE OF A MODULE. FINALLY THE TVSS SHALL COME WITH A FIVE YEAR WARRANTY.
- 3 PROVIDE A KW DEMAND METER AT PAD MOUNTED TRANSFORMER.
- 4 PROVIDE A 3 CONDUCTOR # 2.15 KV CABLE WITH #6 GROUND DIRECT BURIED CABLE FROM SF6 SWITCH TO PAD MOUNTED TRANSFORMER. CABLE SHALL HAVE 133% EPR INSULATION LEVEL AND A RUGGED PVC JACKET. ROUTE CABLE AT LEAST 36" BELOW GRADE AND PROVIDE WARNING TAPE AT 12" BELOW GRADE. SEE SITE PLAN FOR LOCATION OF PAD MOUNTED TRANSFORMER AND SF6 SWITCH. SF6 SWITCH IS SCHEDULED TO BE INSTALLED BY OTHERS.
- 5 PROVIDE INTEGRAL TVSS INSIDE PANELBOARD. THE TVSS SHALL HAVE SURGE CURRENT RATING OF 120 KA PER PHASE AND HAVE INTERRUPT RATING OF 200 KAIR. THE TVSS SHALL EMPLOY A HYBRID DESIGN IN WHICH IN ADDITION TO THE MOV'S IT ALSO HAS A PARALLEL CAPACITIVE FILTER. IT SHALL HAVE A AUDIBLE ALARM (AND SILENCE SWITCH) THAT IS ACTIVATED ON FAILURE OF A MODULE. IT SHALL ALSO COME WITH A NO/NC CONTACT TO INDICATE THE FAILURE OF A MODULE.
- 6 PROVIDE A 250 AMP, 3 POLE, 400 HZ. ENCLOSED SHUNT TRIP CIRCUIT BREAKER. THIS CIRCUIT BREAKER SHALL TRIP WHEN ANY ONE OF THE EMERGENCY PUSH BUTTONS ARE PRESSED.
- 7 PROVIDE A 150 AMP, 3 POLE, 60 HZ SHUNT TRIP CIRCUIT BREAKER. THIS CIRCUIT BREAKER SHALL TRIP WHEN ANY ONE OF THE EMERGENCY PUSH BUTTONS ARE PRESSED.
- 8 PROVIDE A 400 AMP, 2 POLE, DC SHUNT TRIP CIRCUIT BREAKER. THIS CIRCUIT BREAKER SHALL TRIP WHEN ANY ONE OF THE EMERGENCY PUSH BUTTONS ARE PRESSED.

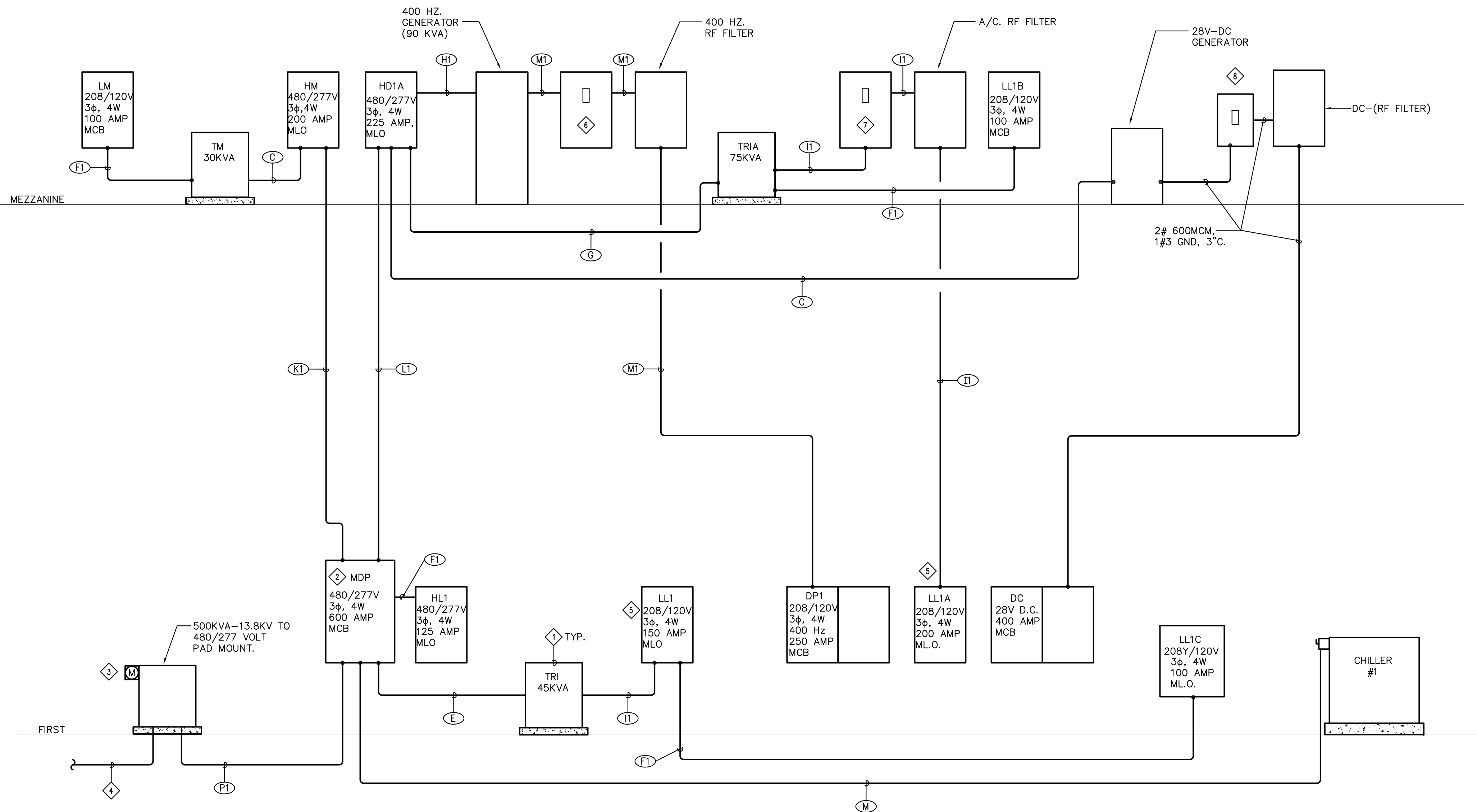

ELECTRICAL RISER DIAGRAM

SCALE: NONE

1
E-9.1

FEEDER SCHEDULE (TYPICAL SCHEDULE - NOT ALL LABELS ARE NECESSARILY USED.)				
LABEL	NO.	SIZE	GND.	CONDUIT
(A)	3	#12	#12	1/2"
(A1)	4	#12	#12	1/2"
(B)	3	#10	#10	3/4"
(B1)	4	#10	#10	3/4"
(C)	3	#8	#10	1"
(C1)	4	#8	#10	1"
(D)	3	#6	#8	1"
(D1)	4	#6	#8	1"
(E)	3	#4	#8	1 1/4"
(E1)	4	#4	#8	1 1/4"
(F)	3	#3	#8	1 1/4"
(F1)	4	#3	#8	1 1/4"
(G)	3	#2	#6	1 1/4"
(G1)	4	#2	#6	1 1/4"
(H)	3	#1	#6	1 1/2"
(H1)	4	#1	#6	1 1/2"
(I)	3	#1/0	#6	1 1/2"
(I1)	4	#1/0	#6	1 1/2"
(J)	3	#2/0	#6	2"
(J1)	4	#2/0	#6	2"
(K)	3	#3/0	#6	2"
(K1)	4	#3/0	#6	2"
(L)	3	#4/0	#4	2"
(L1)	4	#4/0	#4	2 1/2"
(M)	3	#250 MCM	#4	2 1/2"
(M1)	4	#250 MCM	#4	2 1/2"
(N)	3	#350 MCM	#3	3"
(N1)	4	#350 MCM	#3	3"

FEEDER SCHEDULE (TYPICAL SCHEDULE - NOT ALL LABELS ARE NECESSARILY USED.)				
LABEL	NO.	SIZE	GND.	CONDUIT
(O)	3	#500 MCM	#3	3 1/2"
(O1)	4	#500 MCM	#3	3 1/2"
(P)	(2)3	#350 MCM	#1	3"(2 SETS)
(P1)	(2)4	#350 MCM	#1	3"(2 SETS)
(R)	(2)3	#500 MCM	#1/0	4"(2 SETS)
(R1)	(2)4	#500 MCM	#1/0	4"(2 SETS)
(S)	(3)3	#350 MCM	#2/0	3"(3 SETS)
(S1)	(3)4	#350 MCM	#2/0	3"(3 SETS)
(T)	(3)3	#500 MCM	#3/0	4"(3 SETS)
(T1)	(3)4	#500 MCM	#3/0	4"(3 SETS)
(U)	(2)3	#600 MCM	#1/0	4"(2 SETS)
(U1)	(2)4	#600 MCM	#1/0	4"(2 SETS)
(V)	(3)3	#600 MCM	#3/0	4"(3 SETS)
(V1)	(3)4	#600 MCM	#3/0	4"(3 SETS)
(W)	(4)4	#600 MCM	#4/0	4"(4 SETS)
(Y)	(5)4	#600 MCM	250 MCM	4"(5 SETS)
(Z)	4	#600 MCM	#3	4"
(Z1)	4	#600 MCM	#3	4"
(XX)	SEE DRY TRANSFORMER SCHEDULE			

BROADMOOR
BUILDING by DESIGN
BROADMOOR, L.L.C.
2740 North Arnault Road
Metairie, Louisiana 70002
www.broadmoorllc.com

REV.	DESCRIPTION	DATE	APPROVED
0	FINAL DESIGN	10/29/09	P.S.

NAV JRB New Orleans
Belle Chasse, Louisiana
NAVAIRSEFAC CALIBRATION BLDG.
ELECTRICAL RISER DIAGRAM
DATE: AUGUST 14, 2008
ED FOR COMMANDER, NAVFAC



© 2009 IMC 1734
CONSULTING ENGINEERS
INC.
3120 20th STREET
METAIRIE, LOUISIANA 70002

FINAL DESIGN
Oct 29, 2009

WALDEMAR S. NELSON AND COMPANY
REGISTERED ENGINEERS AND ARCHITECTS
1200 ST. CHARLES AVE NEW ORLEANS, LA.

RECORD DRAWING DATE XX-XXX-20XX
CODE I.D. NO. D
DRAWING SIZE: D
SPEC. NO. 06-
CONSTR. CONTR. NO. N62467
NAVFAC DRAWING NO. 15030974
SHEET OF
E-9.0