

Installation Instructions

CONTENTS

	Page
SAFETY CONSIDERATIONS	1
INTRODUCTION	1-23
INSTALLATION	24-52
Storage	24
Step 1 — Rig and Place the Unit.	24
• PLACING UNIT	
• MOUNTING UNIT	
• RIGGING UNIT	
Step 2 — Remove Compressor Rack Holddown Bolts	24
Step 3 — Cooler Fluid and Drain Piping Connections	27
• FREEZE PROTECTION	
• UNITS WITH HYDRONIC PUMP PACKAGE	
• UNITS WITHOUT HYDRONIC PUMP PACKAGE	
• FOR ALL UNITS	
Step 4 — Fill the Chilled Water Loop	31
• WATER SYSTEM CLEANING	
• WATER TREATMENT	
• SYSTEM PRESSURIZATION	
• FILLING THE SYSTEM	
• SET WATER FLOW RATE	
• PUMP MODIFICATION/TRIMMING	
• PREPARATION FOR YEAR-ROUND OPERATION	
• FREEZE PROTECTION	
• PREPARATION FOR WINTER SHUTDOWN	
Step 5 — Make Electrical Connections	41
• POWER SUPPLY	
• POWER WIRING	
• CONTROL POWER	
• FIELD CONTROL OPTION WIRING	
• DUAL CHILLER LEAVING WATER SENSOR	
• CARRIER COMFORT NETWORK COMMUNICATION BUS WIRING	
• NON-CCN COMMUNICATION WIRING	
Step 6 — Install Accessories	52
• NAVIGATOR™ DISPLAY	
• REMOTE ENHANCED DISPLAY	
• LOW AMBIENT OPERATION	
• MINIMUM LOAD ACCESSORY	
• UNIT SECURITY/PROTECTION ACCESSORIES	
• COMMUNICATION ACCESSORIES	
• SERVICE OPTIONS	
Step 7 — Refrigerant Circuit	52
• LEAK TESTING	
• DEHYDRATION	
• REFRIGERANT CHARGE	

SAFETY CONSIDERATIONS

Installing, starting up, and servicing air-conditioning equipment can be hazardous due to system pressures, electrical components, and equipment location.

Only trained, qualified installers and service mechanics should install, start up, and service this equipment.

Untrained personnel can perform basic maintenance functions such as cleaning coils. All other operations should be performed by trained service personnel.

When working on the equipment, observe precautions in the literature and on tags, stickers, and labels attached to the equipment.

- Follow all safety codes.
- Keep quenching cloth and fire extinguisher nearby when brazing.
- Wear safety glasses and work gloves.
- Use care in handling, rigging, and setting bulky equipment.

	<p>ELECTRIC SHOCK HAZARD</p> <p>Open all remote disconnects before servicing this equipment.</p>
--	---

IMPORTANT: This equipment generates, uses, and can radiate radio frequency energy and if not installed and used in accordance with these instructions may cause radio interference. It has been tested and found to comply with the limits of a Class A computing device as defined by FCC (Federal Communications Commission, U.S.A.) regulations, Subpart J of Part 15, which are designed to provide reasonable protection against such interference when operated in a commercial environment.

⚠ CAUTION

This system uses R-410A, which has higher pressures than R-22 and other refrigerants. No other refrigerant may be used in this system. Gage set, hoses, and recovery systems must be designed to handle R-410A refrigerant. If unsure about equipment, consult the equipment manufacturer.

INTRODUCTION

These instructions cover installation of 30RB060-390 air-cooled liquid chillers with electronic controls and units with factory-installed options (FIOPs). See Fig. 1.

NOTE: Unit sizes 315-390 are modular units that are shipped in separate sections as modules A or B as noted in position 8 of the unit model nomenclature. Installation directions specific to these units are noted in these instructions. For modules 315A, 315B, 330A, 330B, 345A, 345B, and 360B, follow all general instructions as noted for unit sizes 30RB160-170. For modules, 360A, 390A, and 390B follow instructions for 30RB190. See Table 1 for a listing of unit sizes and modular combinations.

NOTE: The nameplate for modular units contains only the first two digits in the model number. For example, 315A and 315B name plates read 31A and 31B.

Table 1 — Modular Combinations

MODULE UNITS	MODULE A	MODULE B
30RBA315	30RBA160	30RBA160
30RBA330	30RBA170	30RBA160
30RBA345	30RBA170	30RBA170
30RBA360	30RBA190	30RBA170
30RBA390	30RBA190	30RBA190

NOTE: An "A" in the model number indicates the design series.

Inspect the unit upon arrival for damage. If damage is found, file a claim right away with the shipping company. When considering location for the unit, be sure to consult National Electrical Code (NEC, U.S.A.) and local code requirements. Allow sufficient space for airflow, wiring, piping, and service. See Fig. 2-13. Be sure surface beneath the unit is level, and is capable of supporting the operating weight of the unit. See Fig. 14 and Tables 2A-3B for unit mounting and operating weights.

NOTE: To facilitate refrigerant vent piping all units have fusible plugs with 1/4 in. SAE (Society of Automotive Engineers) flares if required by local codes.

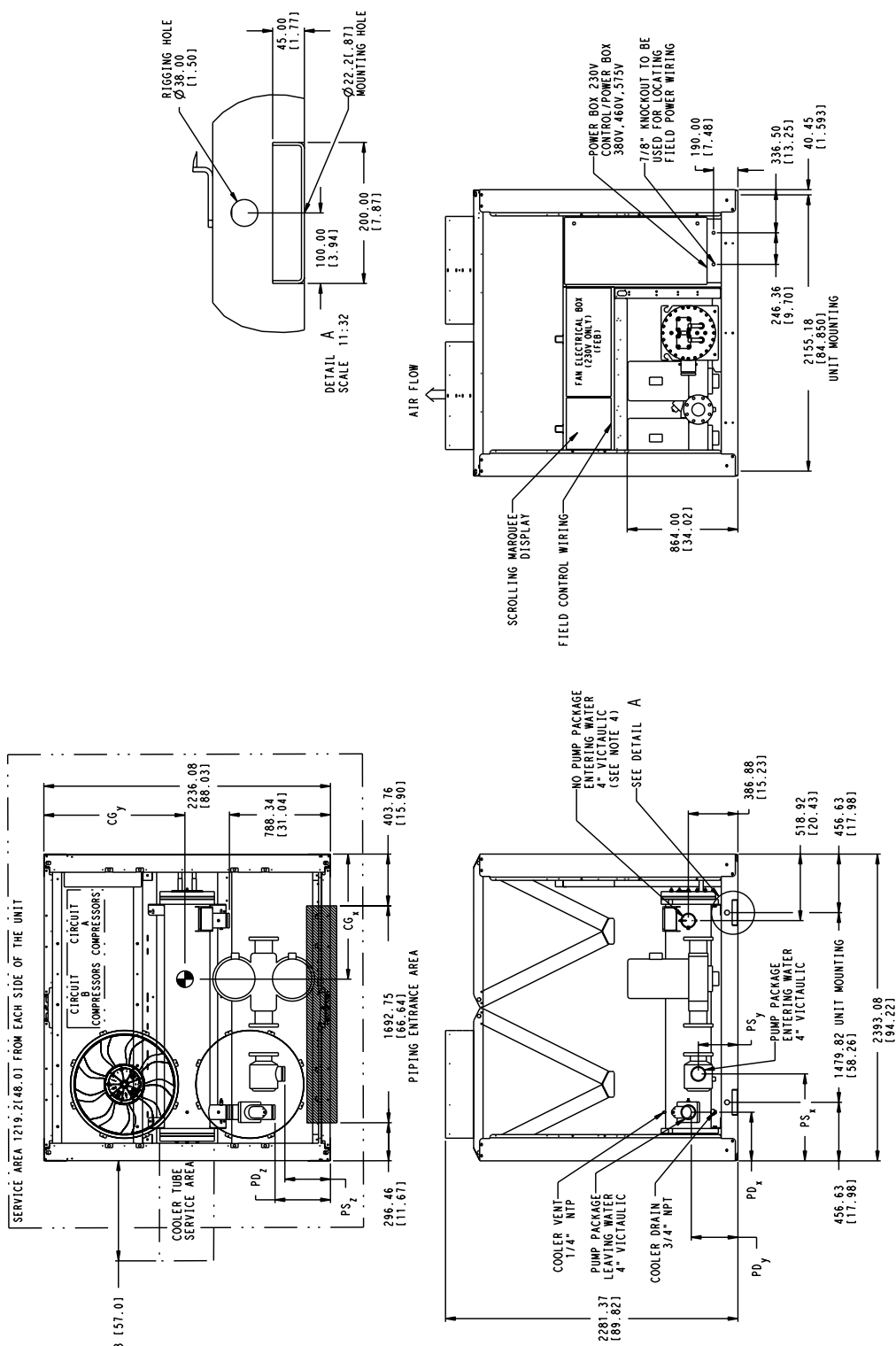

- NOTES:**
- Unit must have clearances as follows:
Top — Do not restrict.
Sides and End — 6" from solid surface.
 - All pumps have drains located at the bottom of volute for draining.
 - Temperature relief devices are located on suction line, liquid line and filter drier of each circuit and have 1/4" flare connection.
 - Units without a pump package have the same leaving water connection, Y and Z dimensions (entering water) and Pump Discharge X dimensions as units with a pump package.
 - Dimensions are in mm [inches].

WEIGHT CU/AL lb/kg	MAX WEIGHT CU/AL lb/kg	WEIGHT CU/AL lb/kg	MAX WEIGHT CU/AL lb/kg	CENTER OF GRAVITY			PUMP SUCTION (PS)			PUMP DISCHARGE (PD)				
				CG _x MM [INCH]	CG _y MM [INCH]	CG _z MM [INCH]	PS _x MM [INCH]	PS _y MM [INCH]	PS _z MM [INCH]	PD _x MM [INCH]	PD _y MM [INCH]	PD _z MM [INCH]		
4335	5258	4817	5740	1206	1012	675.6	309.9	353.1	381.0	391.2	429.3	±.25	±.25	±.25
1966	2385	2185	2604	47.48	39.84	26.6	12.2	13.9	15.0	15.4	16.9			

Fig. 3 — 30RB080 Air-Cooled Chiller Dimensions

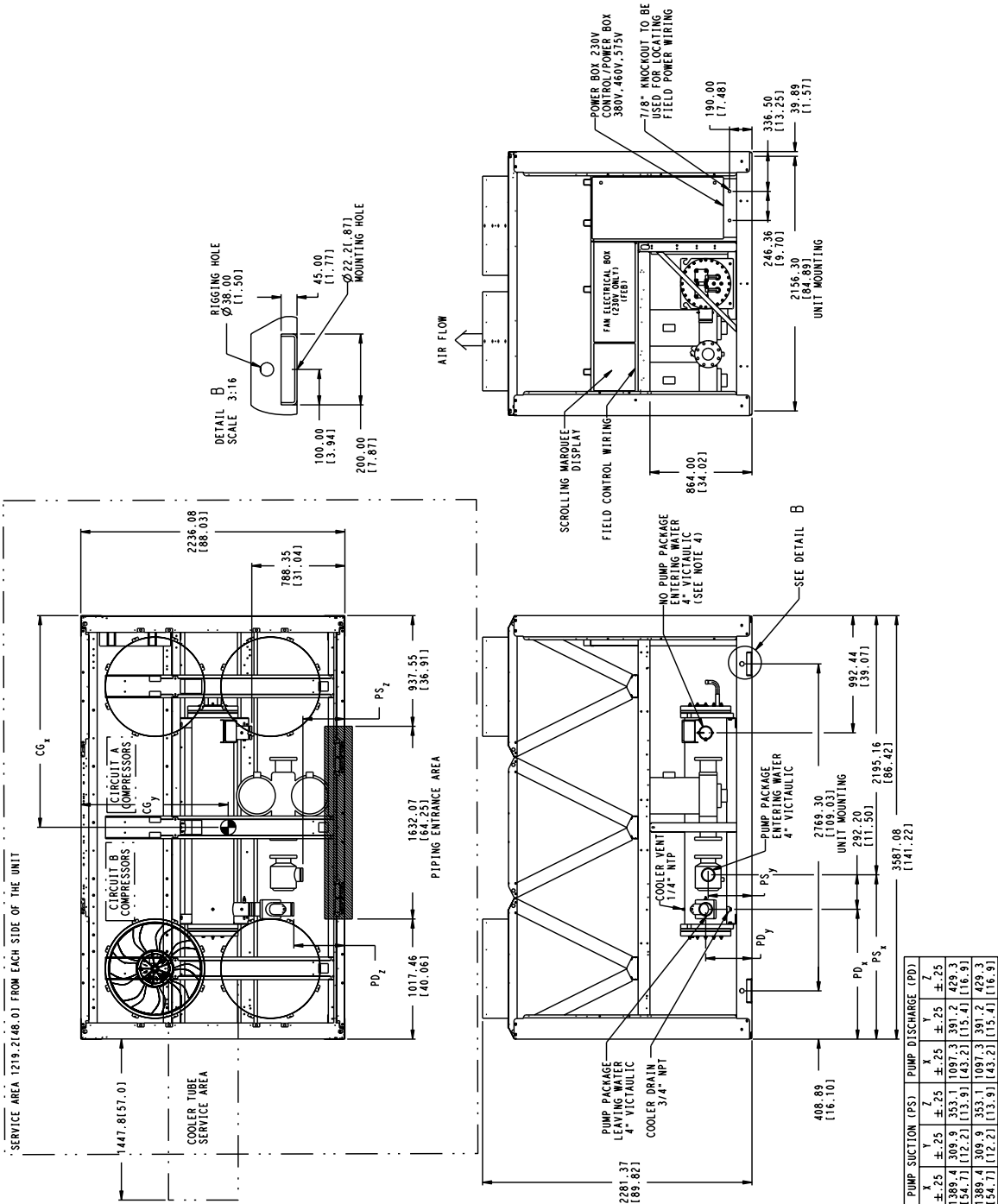

- NOTES:**
1. Unit must have clearances as follows:
Top — Do not restrict.
Sides and End — 6" from solid surface.
 2. All pumps have drains located at the bottom of volute for draining.
 3. Temperature relief devices are located on suction line, liquid line and filter drier of each circuit and have 1/4" flare connection.
 4. Units without a pump package have the same leaving water connection, Y and Z dimensions as units with a pump package.
 5. Dimensions are in mm [inches].

Fig. 4 — 30RB090, 100 Air-Cooled Chiller Dimensions

	WEIGHT CU/AL LBS/KG	MAX WEIGHT CU/AL PUMP LBS/KG	MAX WEIGHT CU/CO PUMP LBS/KG	CENTER OF GRAVITY CG MM [INCH]	PUMP SUCTION (PS)	PUMP DISCHARGE (PD)		
						X	Y	Z
30RB-090	567 [258]	639 [289]	314 [136]	107 [4.2]	±.25 [6.4]	±.25 [6.4]	±.25 [6.4]	±.25 [6.4]
30RB-100	567 [258]	639 [289]	314 [136]	107 [4.2]	±.25 [6.4]	±.25 [6.4]	±.25 [6.4]	±.25 [6.4]

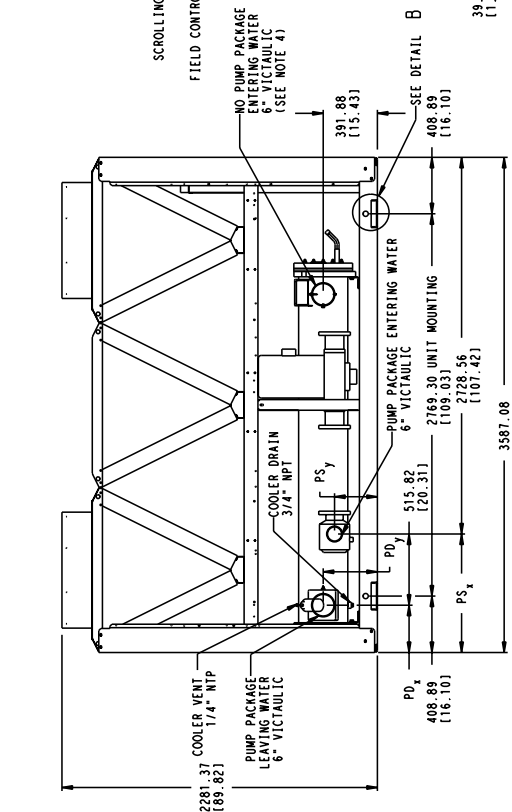
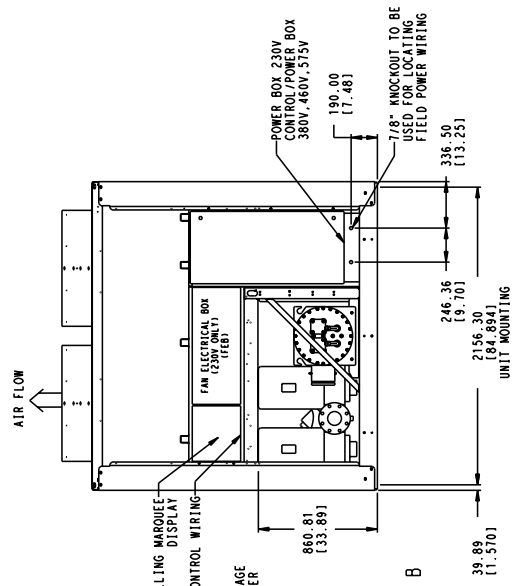
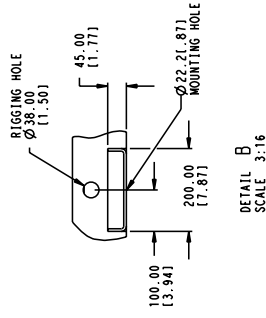
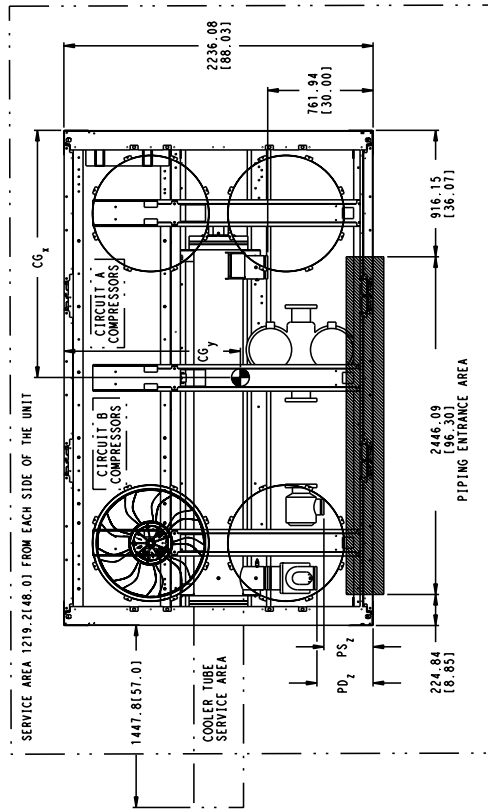

- NOTES:**
- Unit must have clearances as follows:
 - Top — Do not restrict.
 - Sides and End — 6" from solid surface.
 - All pumps have drains located at the bottom of volute for draining.
 - Temperature relief devices are located on suction line, liquid line and filter drier of each circuit and have 1/4" flare connection.
 - Units without a pump package have the same leaving water connection, Y and Z dimensions (entering water) and Pump Discharge X dimensions as units with a pump package.
 - Dimensions are in mm [inches].

WEIGHT CU/L lb/kg	MAX WEIGHT CU/L lb/kg	WEIGHT CU/L lb/kg	MAX WEIGHT CU/L lb/kg	CENTER OF GRAVITY			PUMP SUCTION (PS)			PUMP DISCHARGE (PD)							
				CGx MM [INCH]	CGy MM [INCH]	CGz MM [INCH]	X ±.25	Y ±.25	Z ±.25	X ±.25	Y ±.25	Z ±.25					
6144	7067	6868	7791	1713	997	856.0	281.9	60.9	340.4	391.2	233.7	333.7	111.1	12.4	115.4	19.2	
2781	3206	3115	3534	167.441	139.251	167.441	133.7	111.1	12.4	115.4	19.2	115.4	19.2	115.4	19.2	115.4	19.2

Fig. 5 — 30RB110 Air-Cooled Chiller Dimensions

NOTES:

- Unit must have clearances as follows:
Top — Do not restrict.
Sides and End — 6" from solid surface.
- All pumps have drains located at the bottom of volute for draining.
- Temperature relief devices are located on suction line, liquid line and filter drier of each circuit and have 1/2" flare connection.
- Units without a pump package have the same leaving water connection, Y and Z dimensions (entering water) and Pump Discharge X dimensions as units with a pump package.
- Dimensions are in mm [inches].

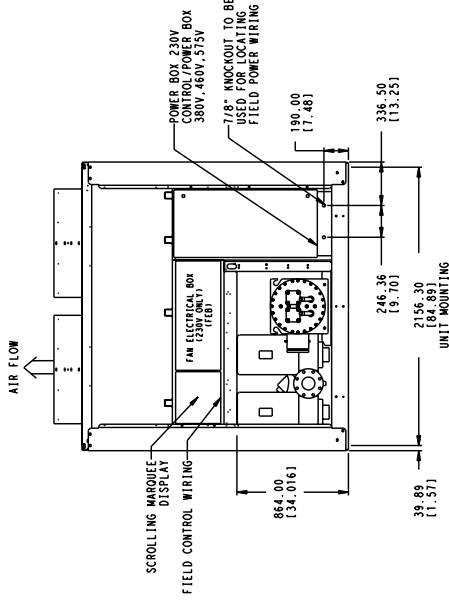
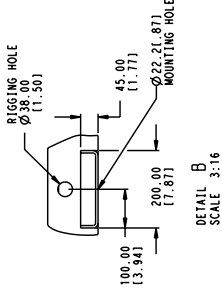
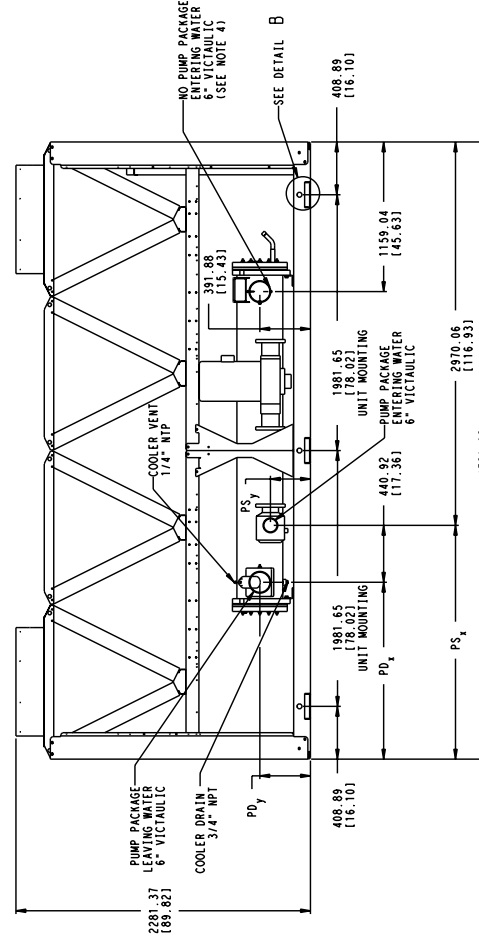
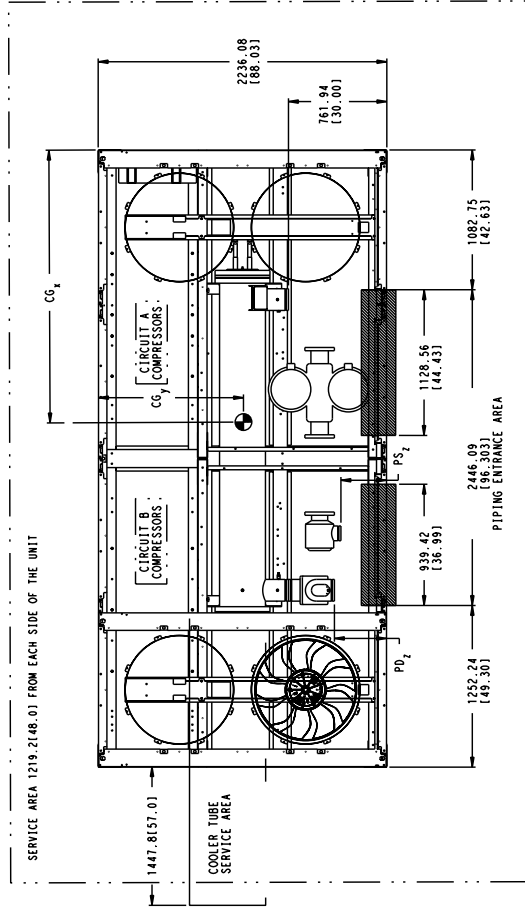

WEIGHT CU/IN	MAX WEIGHT CU/IN	WEIGHT CU/IN	MAX WEIGHT CU/IN	CENTER OF GRAVITY		PUMP SUCTION (PS)		PUMP DISCHARGE (PDI)	
				MM	MM	MM	MM	MM	MM
7215	3170	8238	3170	2345	1808.5	75	75	75	75
3318	3170	3170	3170	(92.36)	(39.09)	(1.1)	(2.4)	(3.0)	(3.0)

Fig. 6 — 30RB120 Air-Cooled Chiller Dimensions

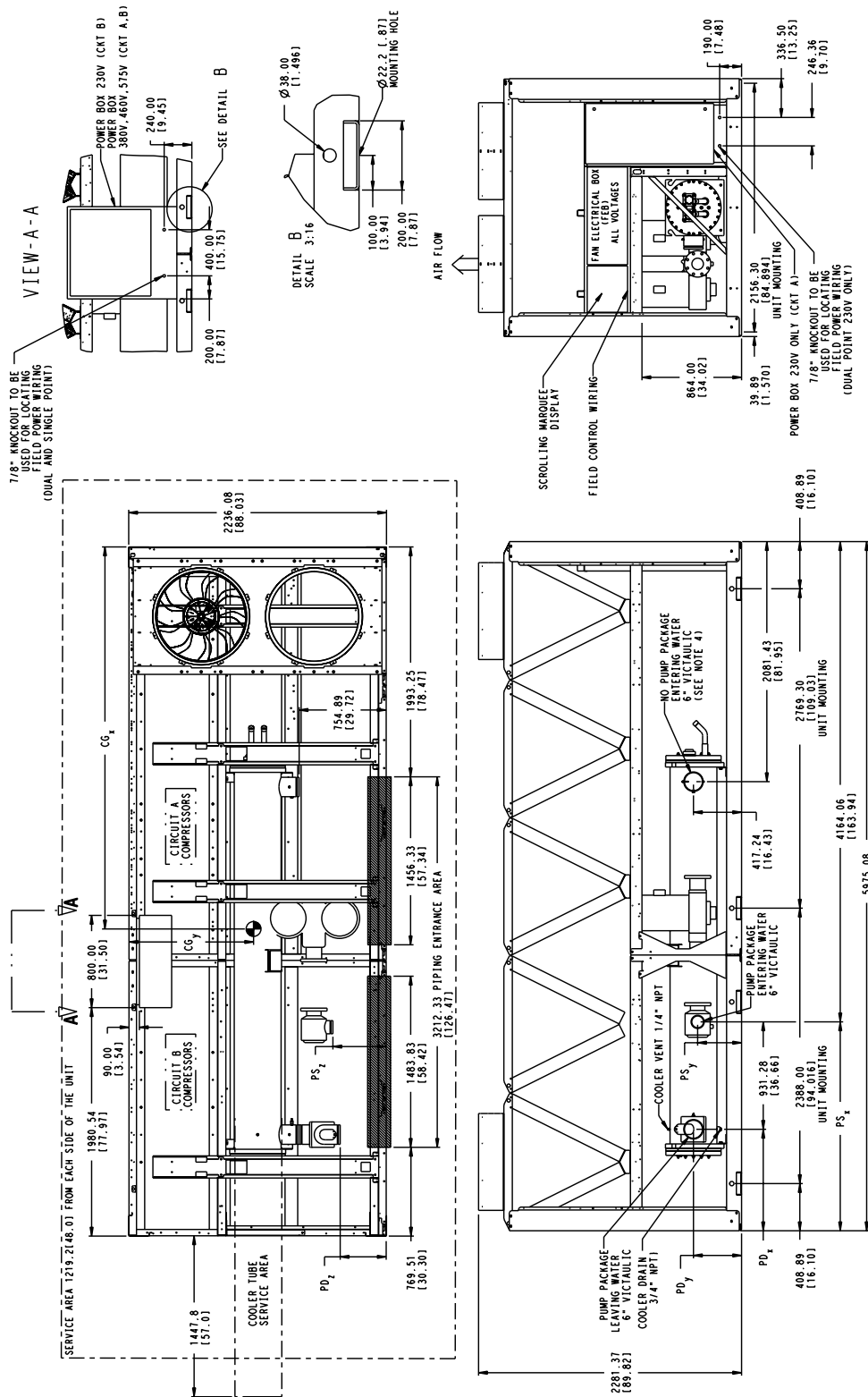

- NOTES:**
- Unit must have clearances as follows:
Top — Do not restrict.
Sides and End — 6" from solid surface.
 - All pumps have drains located at the bottom of volute for draining.
 - Temperature relief devices are located on suction line, liquid line and filter drier of each circuit and have 1/4" flare connection.
 - Units without a pump package have the same leaving water connection, Y and Z dimensions (entering water) and Pump Discharge X dimensions as units with a pump package.
 - Dimensions are in mm [inches].

WEIGHT lb/kg	MAX WEIGHT CU/AL lb/kg	PUMP SUCTION (PS)	CENTER OF GRAVITY			PUMP DISCHARGE (PD)		
			CG _x	CG _y	CG _z	PS _x	PS _y	PS _z
			MM [INCH]	MM [INCH]	MM [INCH]	MM [INCH]	MM [INCH]	MM [INCH]
308B-160	3656	10900	12106	10862	4944	±.25	±.25	±.25
315A/B, 330B	4380	4944	12106	10862	4944	±.25	±.25	±.25
308B-170	9981	11235	12106	10862	4944	±.25	±.25	±.25
330A, 345A/B, 360B	4532	5096	12106	10862	4944	±.25	±.25	±.25

Fig. 8 — 308B-160, 170, 315A/B, 330A/B, 345A/B, 360B Air-Cooled Chiller Dimensions

NOTES:

1. Unit must have clearances as follows:
Top — Do not restrict.
Sides and End — 6' from solid surface.
2. All pumps have drains located at the bottom of volute for draining.
3. Temperature relief devices are located on suction line, liquid line and filter drier of each circuit and have 1/4" flare connection.
4. Dimensions are in mm (inches).

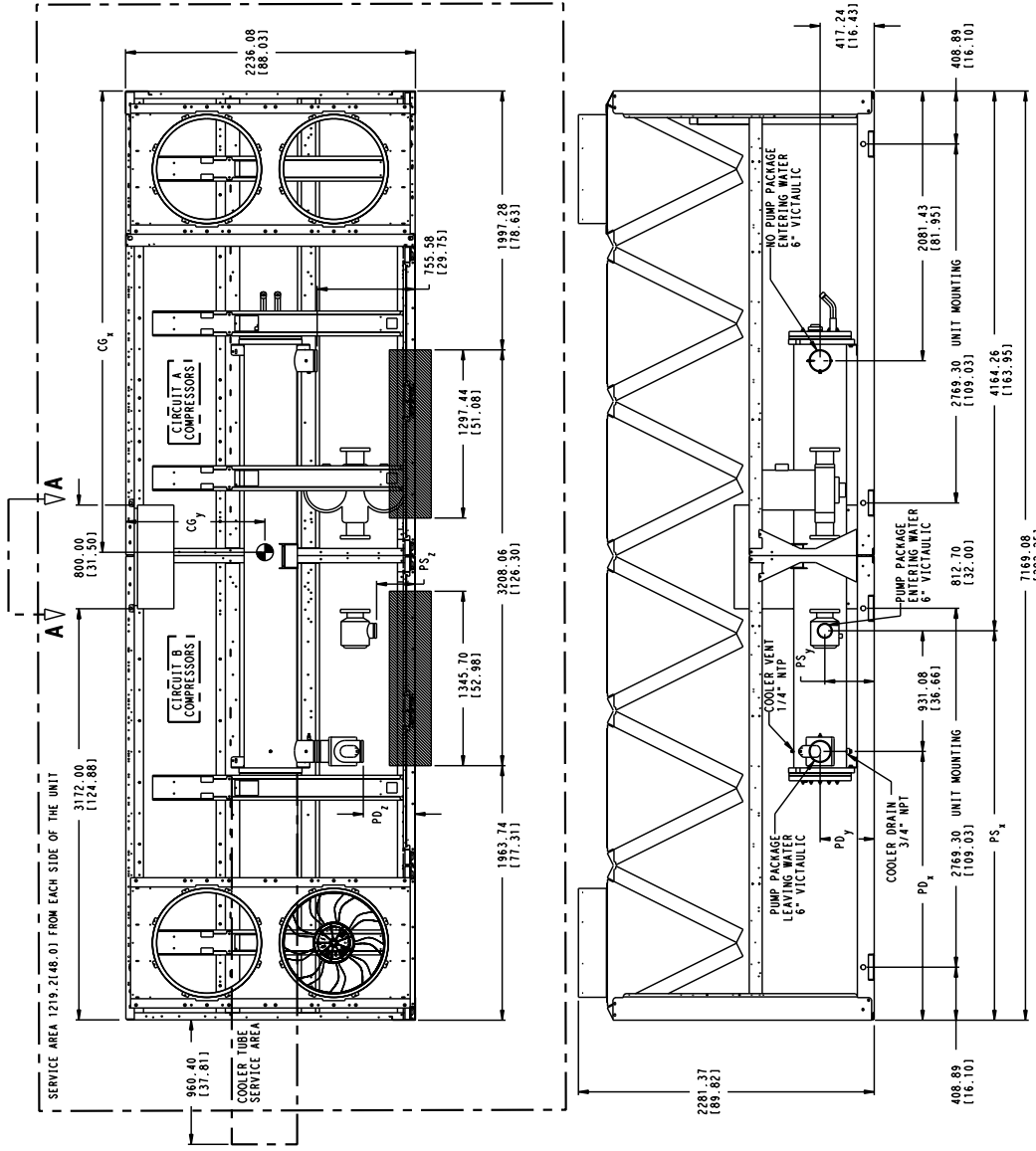

WEIGHT	MAX WEIGHT	WEIGHT	MAX WEIGHT	CENTER OF GRAVITY			PUMP SUCTION (FPS)			PUMP DISCHARGE (PD)				
				CU/AL	CU/AL	MM (INCH)	MM (INCH)	X	Y	Z	X	Y	Z	
11402	12647	12850	14094	3578	974	3002	381	297.2	2800.3	421.6	231.1	±.25	±.25	±.25
360A, 390A/B	5172	5737	6393	1140.87	138.35	118.2	15.0	11.7	81.9	16.6	9.1	±.25	±.25	±.25

Fig. 9 — 30RB190, 360A, 390A/B Air-Cooled Chiller Dimensions

- NOTES:**
- Unit must have clearances as follows:
Top — Do not restrict.
Sides and End — 6" from solid surface.
 - Temperature relief devices are located on suction line, liquid line and filter drier of each circuit and have 1/4" flare connection.
 - Dimensions are in mm [inches].

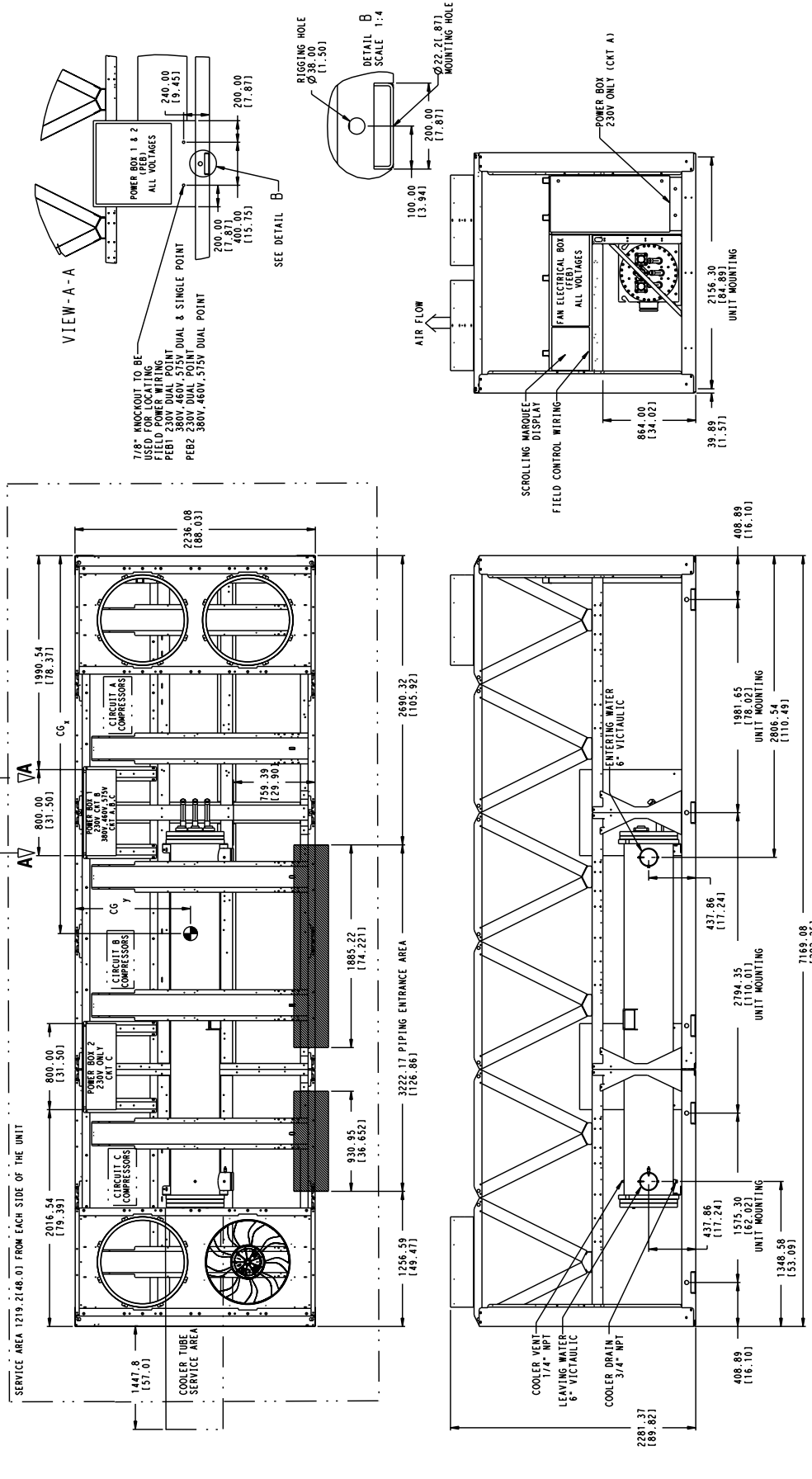
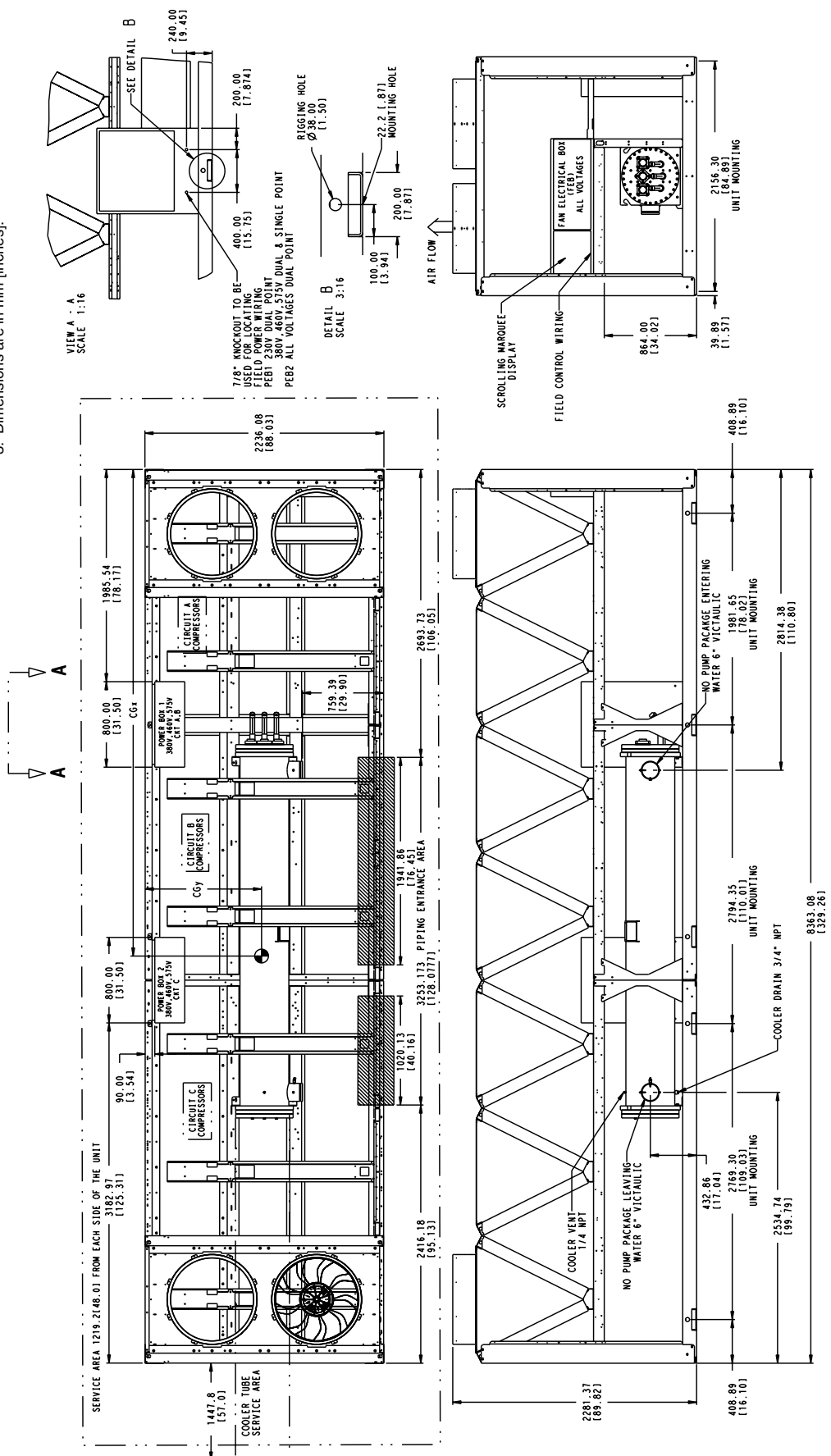

Fig. 10 — 30RB210, 225 Air-Cooled Chiller Dimensions

	WEIGHT CU/AL lb/Kg	CENTER OF GRAVITY	
		CG* MM [INCH]	CG7 MM [INCH]
30RB-210	13019 5925	14466 6582	3528 136.90
30RB-225	13552 6139	14759 5986	3506 135.87

- NOTES:
- Unit must have clearances as follows:
Top — Do not restrict.
Sides and End — 6" from solid surface.
 - Temperature relief devices are located on suction line, liquid line and filter drier of each circuit and have 1/4" flare connection.
 - Dimensions are in mm [inches].



WEIGHT CU/AL PUMP 10/15 12/15 16/15 6692	MAX WEIGHT CU/AL PUMP 10/15 16/15 7458	MAX WEIGHT CU/AL PUMP 10/15 16/15 0	CENTER OF GRAVITY	
			CGx MM (INCH)	CGy MM (INCH)
30RB-250			1158.55 (45.61)	333.86 (13.14)

Fig. 11 — 30RB250 Air-Cooled Chiller Dimensions

- NOTES:**
1. Unit must have clearances as follows:
Top — Do not restrict.
Sides and End — 6' from solid surface.
 2. Temperature relief devices are located on suction line. Liquid line and filter drier of each circuit and have 1/4" flare connection.
 3. Dimensions are in mm [inches].

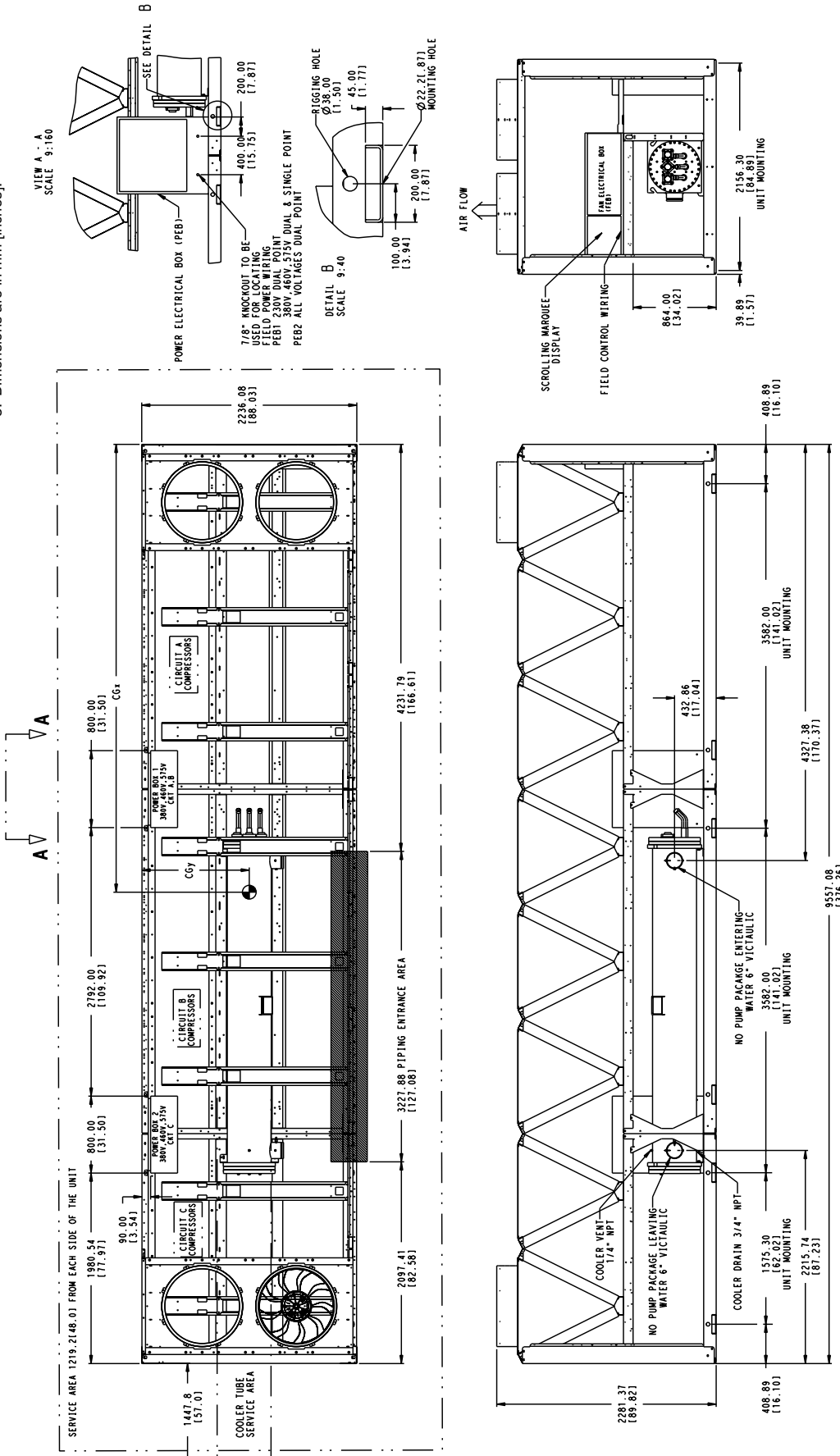

WEIGHT	MAX WEIGHT	WEIGHT	MAX WEIGHT	CENTER OF GRAVITY		
				CGx	CGy	
CU/AL	CU/AL	PUMP	CU/AL	PUMP	MM [INCH]	MM [INCH]
lb/kg	lb/kg	lb/kg	lb/kg	mm [INCH]	mm [INCH]	mm [INCH]
30RB-275	16200	18729	0	4857	914	135.98
	7346	0	8223	0	1191.22	135.98

Fig. 12 — 30RB275 Air-Cooled Chiller Dimensions

NOTES:
 1. Unit must have clearances as follows:
 Top — Do not restrict.
 Sides and End — 6" from solid surface.

- Temperature relief devices are located on suction line, liquid line and filter drier of each circuit and have 1/4" flare connection.
- Dimensions are in mm [inches].

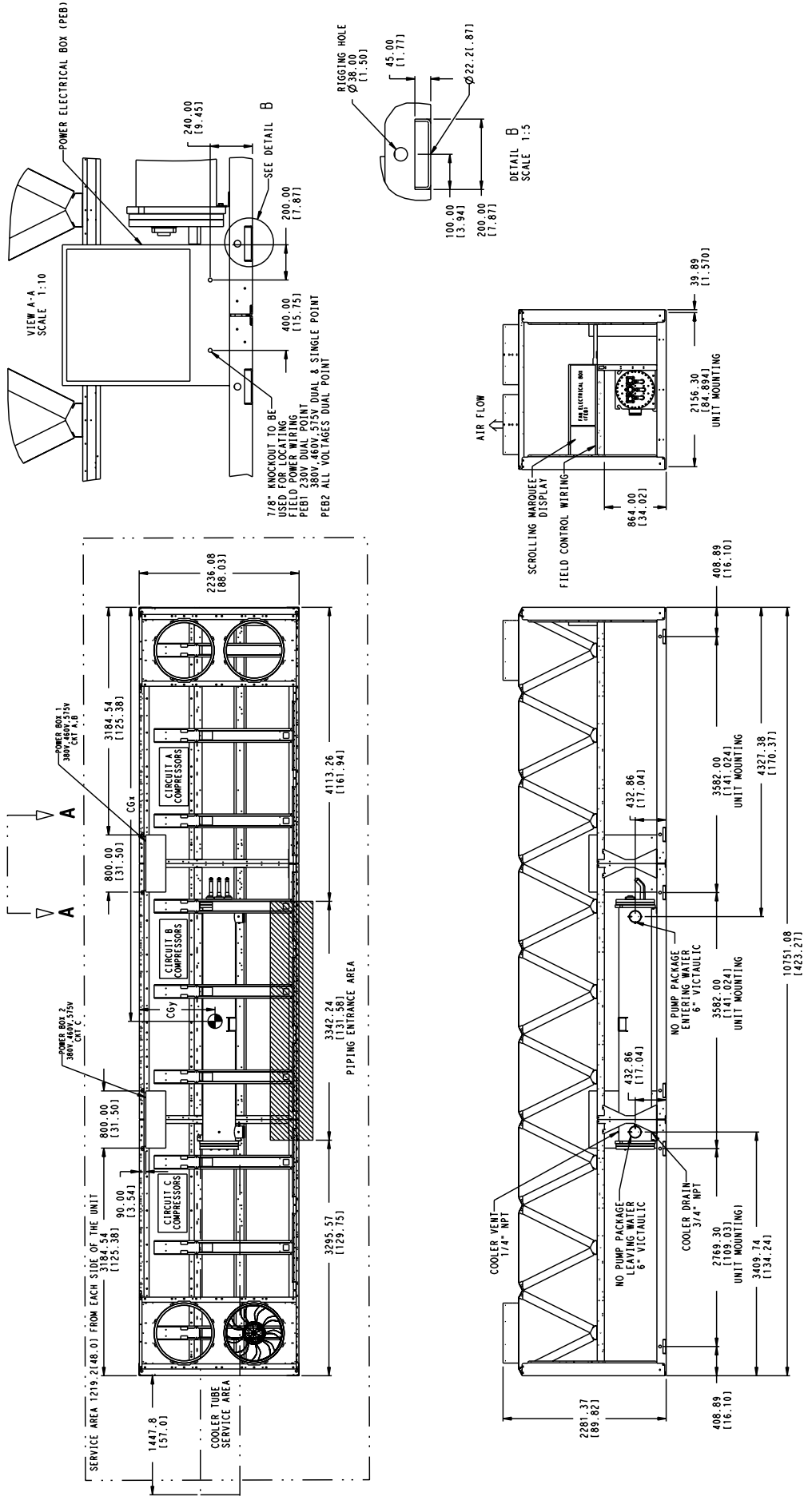

WEIGHT	MAX WEIGHT	WEIGHT	MAX WEIGHT	CENTER OF GRAVITY	
CU/AL	CU/AL	CU/AL	CU/AL	CG	
lb/kg	lb/kg	lb/kg	lb/kg	MM (INCH)	
30RB-300	17591	0	19762	5317	918
	7979	0	8964	203.33	36.06

Fig. 13 — 30RB300 Air-Cooled Chiller Dimensions

Units Without Pumps — English

UNIT 30RB	MOUNTING WEIGHT (lb) No Pump Al/Cu*				
	A	B	C	D	Total
060	806	856	1138	1072	3872
070	829	878	1219	1151	4077
080	913	895	1251	1276	4335
090	1095	1328	1778	1466	5667
100	1109	1362	1884	1535	5890
110	1211	1368	1891	1674	6144
120	1535	1550	2125	2104	7315
130	1544	1665	2315	2147	7671
150	1798	1762	2477	2527	8564

UNIT 30RB	MOUNTING WEIGHT (lb) No Pump Al/Cu*						
	A	B	C	D	E	F	Total
160	996	2055	1041	1423	2795	1345	9655
170	1033	2086	1045	1427	2912	1487	9990

UNIT 30RB	MOUNTING WEIGHT (lb) No Pump Al/Cu*								
	A	B	C	D	E	F	G	H	Total
190	1031	1298	1393	1038	1419	1911	1844	1467	11,402
210	841	1676	1984	853	1311	2872	2324	1157	13,018
225	871	1709	1989	855	1313	2877	2452	1283	13,351
250	1070	2119	1979	850	1307	2863	3019	1544	14,752
275	627	2086	2631	1292	1866	3634	2984	1080	16,199
300	899	2418	2617	1284	1859	3621	3455	1435	17,590

Units Without Pumps — SI

UNIT 30RB	MOUNTING WEIGHT (kg) No Pump Al/Cu*				
	A	B	C	D	Total
060	366	388	516	486	1756
070	376	398	553	522	1849
080	414	406	568	579	1966
090	497	602	806	665	2571
100	503	618	855	696	2672
110	549	621	858	759	2787
120	696	703	964	955	3318
130	700	755	1050	974	3480
150	815	799	1124	1146	3885

UNIT 30RB	MOUNTING WEIGHT (kg) No Pump Al/Cu*						
	A	B	C	D	E	F	Total
160	452	932	472	645	1268	610	4379
170	469	946	474	647	1321	675	4531

UNIT 30RB	MOUNTING WEIGHT (kg) No Pump Al/Cu*								
	A	B	C	D	E	F	G	H	Total
190	468	589	632	471	644	867	836	666	5172
210	381	760	900	387	595	1303	1054	525	5905
225	395	775	902	388	596	1305	1112	582	6056
250	485	961	898	386	593	1299	1369	700	6691
275	284	946	1193	586	846	1648	1354	490	7348
300	408	1097	1187	583	843	1642	1567	651	7979

UNIT 30RB	MOUNTING WEIGHT (lb) No Pump Cu/Cu†				
	A	B	C	D	Total
060	929	980	1255	1190	4354
070	951	1002	1337	1269	4560
080	1036	1018	1369	1393	4817
090	1278	1515	1952	1646	6391
100	1291	1550	2058	1715	6614
110	1395	1555	2066	1853	6868
120	1751	1766	2331	2311	8159
130	1789	1913	2549	2384	8635
150	2045	2008	2713	2763	9528

UNIT 30RB	MOUNTING WEIGHT (lb) No Pump Cu/Cu†						
	A	B	C	D	E	F	Total
160	1142	2364	1203	1582	3089	1481	10,861
170	1180	2394	1207	1586	3207	1623	11,196

UNIT 30RB	MOUNTING WEIGHT (lb) No Pump Cu/Cu†								
	A	B	C	D	E	F	G	H	Total
190	1194	1506	1601	1200	1578	2106	2039	1625	12,849
210	943	1917	2255	978	1427	3126	2564	1255	14,465
225	973	1950	2260	981	1429	3131	2693	1381	14,798
250	1232	2425	2249	976	1423	3117	3316	1704	16,441
275	732	2371	3018	1501	2059	4011	3262	1175	18,129
300	1064	2766	3005	1494	2053	3998	3790	1591	19,761

UNIT 30RB	MOUNTING WEIGHT (kg) No Pump Cu/Cu†				
	A	B	C	D	Total
060	421	444	569	540	1975
070	432	455	607	576	2068
080	470	462	621	632	2185
090	580	687	885	747	2899
100	586	703	934	778	3000
110	633	705	937	840	3115
120	794	801	1057	1048	3701
130	811	868	1156	1081	3917
150	928	911	1230	1253	4322

UNIT 30RB	MOUNTING WEIGHT (kg) No Pump Cu/Cu†						
	A	B	C	D	E	F	Total
160	518	1072	546	717	1401	672	4927
170	535	1086	548	719	1455	736	5078

UNIT 30RB	MOUNTING WEIGHT (kg) No Pump Cu/Cu†								
	A	B	C	D	E	F	G	H	Total
190	542	683	726	544	716	955	925	737	5828
210	428	870	1023	444	647	1418	1163	569	6561
225	442	885	1025	445	648	1420	1222	627	6712
250	559	1100	1020	443	645	1414	1504	773	7457
275	332	1075	1369	681	934	1819	1479	533	8223
300	483	1255	1363	678	931	1814	1719	722	8964

LEGEND

Al — Aluminum
 Cu — Copper
 *Condenser Coil: Aluminum Fins/Copper Tubing.
 †Condenser Coil: Copper Fins/Copper Tubing.

30RB060-150

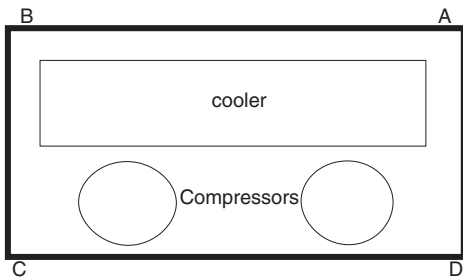

30RB160-170, 315A, 315B, 330A, 330B, 345A, 345B, 360B

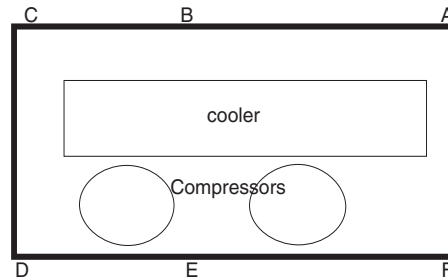

30RB190-300, 360A, 390A, 390B

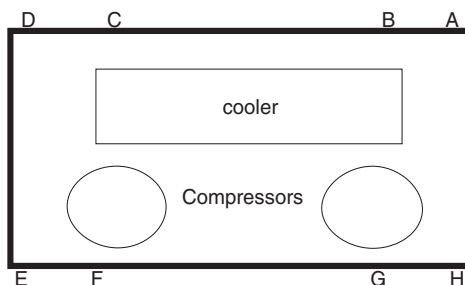

NOTE: Corner weights are calculated at mounting locations. Refer to Fig. 2-13 (certified drawings) for mounting locations.

Fig. 14 — Unit Weights

Single Pump Units — English

UNIT 30RB	MOUNTING WEIGHT (lb) Single Pump Al/Cu*				
	A	B	C	D	Total
060	1022	1070	1174	1121	4387
070	1044	1093	1256	1200	4593
080	1123	1102	1292	1318	4835
090	1289	1551	1817	1510	6167
100	1302	1586	1923	1579	6390
110	1455	1575	1899	1755	6684
120	1732	1805	2204	2115	7855
130	1737	1923	2391	2160	8210
150	2045	2042	2563	2567	9216

UNIT 30RB	MOUNTING WEIGHT (lb) Single Pump Al/Cu*						
	A	B	C	D	E	F	Total
160	1126	2452	1041	1423	3025	1241	10,308
170	1169	2477	1045	1427	3148	1378	10,643

UNIT 30RB	MOUNTING WEIGHT (lb) Single Pump Al/Cu*								
	A	B	C	D	E	G	H	Total	
190	1031	1420	1798	1038	1419	2085	1796	1467	12,055

UNIT 30RB	MOUNTING WEIGHT (lb) Single Pump Cu/Cu†				
	A	B	C	D	Total
060	1145	1194	1292	1239	4,869
070	1167	1216	1374	1318	5,075
080	1247	1225	1410	1435	5,317
090	1473	1738	1992	1688	6,891
100	1485	1773	2098	1758	7,114
110	1640	1761	2075	1933	7,408
120	1947	2021	2410	2321	8,699
130	1982	2171	2625	2397	9,175
150	2292	2288	2799	2803	10,181

UNIT 30RB	MOUNTING WEIGHT (lb) Single Pump Cu/Cu†						
	A	B	C	D	E	F	Total
160	1270	2763	1203	1582	3317	1380	11,514
170	1313	2788	1207	1586	3440	1516	11,849

UNIT 30RB	MOUNTING WEIGHT (lb) Single Pump Cu/Cu†								
	A	B	C	D	E	F	G	H	Total
190	1194	1629	2005	1200	1578	2281	1991	1625	13,502

LEGEND

Al — Aluminum
Cu — Copper

*Condenser Coil: Aluminum Fins/Copper Tubing.
†Condenser Coil: Copper Fins/Copper Tubing.

Dual Pump Units — English

UNIT 30RB	MOUNTING WEIGHT (lb) Dual Pump Al/Cu*				
	A	B	C	D	Total
060	1155	1202	1197	1150	4705
070	1177	1225	1279	1229	4911
080	1302	1276	1327	1353	5258
090	1453	1740	1851	1546	6590
100	1466	1775	1957	1616	6813
110	1631	1719	1908	1810	7067
120	1869	1987	2258	2124	8238
130	1872	2107	2443	2171	8593
150	2267	2297	2639	2605	9808

UNIT 30RB	MOUNTING WEIGHT (lb) Dual Pump Al/Cu*						
	A	B	C	D	E	F	Total
160	1221	2834	1041	1423	3211	1169	10,900
170	1270	2854	1045	1427	3339	1301	11,235

UNIT 30RB	MOUNTING WEIGHT (lb) Dual Pump Al/Cu*								
	A	B	C	D	E	F	G	H	Total
190	1031	1498	2198	1038	1419	2210	1785	1467	12,647

UNIT 30RB	MOUNTING WEIGHT (lb) Dual Pump Cu/Cu†				
	A	B	C	D	Total
060	1278	1326	1315	1268	5,187
070	1300	1348	1397	1347	5,393
080	1425	1399	1445	1471	5,740
090	1638	1926	2027	1724	7,314
100	1650	1961	2132	1794	7,537
110	1815	1904	2084	1987	7,791
120	2084	2203	2464	2331	9,082
130	2118	2355	2678	2408	9,558
150	2513	2544	2875	2841	10,773

UNIT 30RB	MOUNTING WEIGHT (lb) Dual Pump Cu/Cu†						
	A	B	C	D	E	F	Total
160	1366	3144	1203	1582	3504	1307	12,106
170	1413	3164	1207	1586	3631	1439	12,441

UNIT 30RB	MOUNTING WEIGHT (lb) Dual Pump Cu/Cu†								
	A	B	C	D	E	F	G	H	Total
190	1194	1709	2402	1200	1578	2409	1977	1625	14,094

LEGEND

Al — Aluminum
Cu — Copper

*Condenser Coil: Aluminum Fins/Copper Tubing.
†Condenser Coil: Copper Fins/Copper Tubing.

Single Pump Units — SI

UNIT 30RB	MOUNTING WEIGHT (kg) Single Pump Al/Cu*				
	A	B	C	D	Total
060	463	486	533	508	1990
070	473	496	570	544	2083
080	510	500	586	598	2193
090	585	704	824	685	2797
100	591	719	872	716	2898
110	660	714	861	796	3032
120	785	819	1000	959	3563
130	788	872	1084	980	3724
150	928	926	1162	1164	4180

UNIT 30RB	MOUNTING WEIGHT (kg) Single Pump Al/Cu*						
	A	B	C	D	E	F	Total
160	511	1112	472	645	1372	563	4676
170	530	1124	474	647	1428	625	4828

UNIT 30RB	MOUNTING WEIGHT (kg) Single Pump Al/Cu*								
	A	B	C	D	E	F	G	H	Total
190	468	644	816	471	644	946	815	666	5468

UNIT 30RB	MOUNTING WEIGHT (kg) Single Pump Cu/Cu†				
	A	B	C	D	Total
060	519	542	586	562	2209
070	529	552	623	598	2302
080	566	556	640	651	2412
090	668	788	904	766	3126
100	674	804	952	797	3227
110	744	799	941	877	3360
120	883	917	1093	1053	3946
130	899	985	1191	1087	4162
150	1039	1038	1269	1271	4618

UNIT 30RB	MOUNTING WEIGHT (kg) Single Pump Cu/Cu†						
	A	B	C	D	E	F	Total
160	576	1253	546	717	1505	626	5223
170	595	1264	548	719	1560	688	5375

UNIT 30RB	MOUNTING WEIGHT (kg) Single Pump Cu/Cu†								
	A	B	C	D	E	F	G	H	Total
190	542	739	909	544	716	1035	903	737	6124

Dual Pump Units — SI

UNIT 30RB	MOUNTING WEIGHT (kg) Dual Pump Al/Cu*				
	A	B	C	D	Total
060	524	545	543	522	2134
070	534	556	580	558	2228
080	590	579	602	614	2385
090	659	789	840	701	2989
100	665	805	887	733	3090
110	740	780	865	821	3206
120	848	901	1024	963	3737
130	849	956	1108	985	3898
150	1028	1042	1197	1181	4449

UNIT 30RB	MOUNTING WEIGHT (kg) Dual Pump Al/Cu*						
	A	B	C	D	E	F	Total
160	554	1286	472	645	1456	530	4944
170	576	1294	474	647	1515	590	5096

UNIT 30RB	MOUNTING WEIGHT (kg) Dual Pump Al/Cu*								
	A	B	C	D	E	F	G	H	Total
190	468	680	997	471	644	1002	810	666	5737

UNIT 30RB	MOUNTING WEIGHT (kg) Dual Pump Cu/Cu†				
	A	B	C	D	Total
060	580	601	597	575	2353
070	590	612	634	611	2446
080	646	635	655	667	2604
090	743	873	919	782	3318
100	748	890	967	814	3419
110	824	864	945	901	3534
120	945	999	1118	1057	4120
130	961	1068	1215	1092	4335
150	1140	1154	1304	1289	4887

UNIT 30RB	MOUNTING WEIGHT (kg) Dual Pump Cu/Cu†						
	A	B	C	D	E	F	Total
160	619	1426	546	717	1589	593	5491
170	641	1435	548	719	1647	653	5643

UNIT 30RB	MOUNTING WEIGHT (kg) Dual Pump Cu/Cu†								
	A	B	C	D	E	F	G	H	Total
190	542	775	1089	544	716	1093	897	737	6393

Fig. 14 — Unit Weights (cont)

Table 2A — Physical Data, 30RB060-300 — English

UNIT 30RB	060	070	080	090	100	110	120	130	150
OPERATING WEIGHT (lb)*									
Al-Cu Condenser Coil	4705	4911	5258	6590	6813	7067	8238	8593	9,808
Cu-Cu Condenser Coil	5187	5393	5740	7314	7537	7791	9082	9558	10,773
REFRIGERANT TYPE	R-410A, EXV Controlled System								
Refrigerant Charge (lb)									
Ckt A/Ckt B/Ckt C	89.5/40.5/—	112/40.5/—	68.5/68.5/—	96/76/—	96/96/—	96/106/—	96/133/—	133/106/—	133/133/—
COMPRESSORS	Scroll, Hermetic								
Quantity	3	3	4	4	4	5	5	6	6
Speed (rpm)	3500								
(Qty) Compressor Nominal Capacity (ton) Ckt A	(2) 20	(2) 25	(2) 20	(2) 25	(2) 25	(2) 25	(2) 25	(3) 25	(3) 25
(Qty) Compressor Nominal Capacity (ton) Ckt B	(1) 20	(1) 20	(2) 20	(2) 20	(2) 25	(3) 20	(3) 25	(3) 20	(3) 25
(Qty) Compressor Nominal Capacity (ton) Ckt C	N/A	N/A	N/A	N/A	N/A	N/A	N/A	N/A	N/A
Oil Charge (Pt. Ckt A/Ckt B/Ckt C)	26.2/13.1/—	26.2/13.1/—	26.2/26.2/—	26.2/26.2/—	26.2/26.2/—	26.2/39.4/—	26.2/39.4/—	39.4/39.4/—	39.4/39.4/—
No. Capacity Steps									
Standard	3	3	4	4	4	5	5	6	6
Optional (Maximum)	4	4	5	5	5	6	6	7	7
Minimum Capacity Step (%)									
Standard	33	29	25	22	25	18	20	15	17
Optional	22	19	16	14	18	12	14	10	12
Capacity (%)									
Ckt A	67	71	50	56	50	45	40	56	50
Ckt B	33	29	50	44	50	55	60	44	50
Ckt C	N/A	N/A	N/A	N/A	N/A	N/A	N/A	N/A	N/A
COOLER	Direct Expansion, Shell and Tube Type								
Weight (empty, lb)	715	715	856	856	856	970	970	970	1518
Net Fluid Volume (gal)	28.2	28.2	31.3	31.3	31.3	45.8	45.8	45.8	73.5
Maximum Refrigerant Pressure (psig)	445	445	445	445	445	445	445	445	445
Maximum Fluid Side Pressure Without Pumps (psig)	300	300	300	300	300	300	300	300	300
Maximum Fluid Side Pressure With Pumps (psig)	150	150	150	150	150	150	150	150	150
FLUID CONNECTIONS (in.)									
Inlet and Outlet, Victaulic	4	4	4	4	4	6	6	6	6
Drain (NPT)	3/4	3/4	3/4	3/4	3/4	3/4	3/4	3/4	3/4
CONDENSER FANS	Shrouded Axial Type, Vertical Discharge								
Standard Low Noise Type									
Fan Speed (rpm) Standard/Low Noise	1140	1140	1140	1140	1140	1140	1140	1140	1140
No. Blades...Diameter (in.)	9...30	9...30	9...30	9...30	9...30	9...30	9...30	9...30	9...30
No. Fans (Ckt A/Ckt B/Ckt C)	3/1/—	3/1/—	2/2/—	3/3/—	3/3/—	3/3/—	3/4/—	4/4/—	4/4/—
Total Airflow (cfm)	49,600	49,600	49,600	74,400	74,400	74,400	86,800	99,200	99,200
CONDENSER COILS	3/4-in. OD, Plate Fin, Enhanced Copper Tubing								
No. Coils (Ckt A/Ckt B/Ckt C)	3/1/—	3/1/—	2/2/—	3/3/—	3/3/—	3/3/—	3/4/—	4/4/—	4/4/—
Total Face Area (sq ft)	94	94	94	141	141	141	164	188	188
No. Rows (Ckt A or B or C)	3	3	3	3	3	3	3	3	3
Max Working Refrigerant Pressure (psig)	656	656	656	656	656	656	656	656	656
HYDRONIC MODULE (Optional)	Pump(s) with pressure/temperature taps and combination valve.								
Pump	Single or Dual, 1800 or 3600 rpm								
CHASSIS DIMENSIONS (ft-in.)									
Length	7-11		11-10				15-9		
Width	7-4 ²⁵ / ₃₂								
Height	7-6 ⁷ / ₁₆								

LEGEND

- Al — Aluminum
- Cu — Copper
- EXV — Electronic Expansion Valve
- N/A — Not Applicable

*Operating weight includes 2 pumps on Models 30RB060-190. No pumps are available on models larger than 30RB190.

Table 2A — Physical Data, 30RB060-300 — English (cont)

UNIT 30RB	160	170	190	210	225	250	275	300
OPERATING WEIGHT (lb)* Al-Cu Condenser Coil Cu-Cu Condenser Coil	10,900 12,106	11,235 12,441	12,647 14,094	13,018 14,465	13,351 14,798	14,752 16,441	16,199 18,129	17,590 19,761
REFRIGERANT TYPE Refrigerant Charge (lb) Ckt A/Ckt B/Ckt C	R-410A, EXV Controlled System							
	162/106/—	162/133/—	162/162/—	133/106/133	133/133/133	133/133/162	162/162/133	162/162/162
COMPRESSORS Quantity Speed (rpm) (Qty) Compressor Nominal Capacity (ton) Ckt A (Qty) Compressor Capacity (ton) Ckt B (Qty) Compressor Capacity (ton) Ckt C Oil Charge (Pt. Ckt A/Ckt B/Ckt C) No. Capacity Steps Standard Optional (Maximum) Minimum Capacity Step (%) Standard Optional Capacity (%) Ckt A Ckt B Ckt C	Scroll, Hermetic 3500							
	7	7	8	9	9	10	11	12
	(4) 25	(4) 25	(4) 25	(3) 25	(3) 25	(3) 25	(4) 25	(4) 25
	(3) 20	(3) 25	(4) 25	(3) 20	(3) 25	(3) 25	(4) 25	(4) 25
	N/A	N/A	N/A	(3) 25	(3) 25	(4) 25	(3) 25	(4) 25
	52.5/39.4/—	52.5/39.4/—	52.5/52.5/—	39.4/39.4/39.4	39.4/39.4/39.4	39.4/39.4/52.5	52.5/52.5/39.4	52.5/52.5/52.5
	7	7	8	9	9	10	11	12
	8	8	9	10	10	11	12	13
	13	14	13	10	11	10	9	8
	8	10	9	6	8	7	7	6
	62	57	50	36	33	30	36	33
	38	43	50	28	33	30	36	33
	N/A	N/A	N/A	36	33	40	28	33
COOLER Weight (empty, lb) Net Fluid Volume (gal) Maximum Refrigerant Pressure (psig) Maximum Fluid Side Pressure Without Pumps (psig) Maximum Fluid Side Pressure With Pumps (psig)	Direct Expansion, Shell and Tube Type							
	1518	1518	1518	2382	2382	2382	2382	2382
	73.5	73.5	73.5	86.6	86.6	86.6	86.6	86.6
	445	445	445	445	445	445	445	445
	300	300	300	300	300	300	300	300
	150	150	150	150	150	150	150	150
FLUID CONNECTIONS (in.) Inlet and Outlet, Victaulic Drain (NPT)	6 3/4	6 3/4	6 3/4	6 3/4	6 3/4	6 3/4	6 3/4	6 3/4
CONDENSER FANS Standard Low Noise Type Fan Speed (rpm) Standard/Low Noise No. Blades...Diameter (in.) No. Fans (Ckt A/Ckt B/Ckt C) Total Airflow (cfm)	Shrouded Axial Type, Vertical Discharge							
	1140	1140	1140	1140	1140	1140	1140	1140
	9...30	9...30	9...30	9...30	9...30	9...30	9...30	9...30
	6/4/—	6/4/—	6/6/—	4/4/4	4/4/4	4/4/6	6/6/4	6/6/6
	124,000	124,000	148,800	148,800	148,800	173,600	198,400	223,200
CONDENSER COILS No. Coils (Ckt A/Ckt B/Ckt C) Total Face Area (sq ft) No. Rows (Ckt A or B or C) Max Working Refrigerant Pressure (psig)	3/4-in. OD, Plate Fin, Enhanced Copper Tubing							
	6/4/—	6/4/—	6/6/—	4/4/4	4/4/4	4/4/6	6/6/4	6/6/6
	235	235	282	282	282	328	375	422
	3	3	3	3	3	3	3	3
	656	656	656	656	656	656	656	656
HYDRONIC MODULE (Optional) Pump	Pump(s) with pressure/temperature taps and combination valve. Single or Dual, 1800 or 3600 rpm				Not available			
CHASSIS DIMENSIONS (ft-in.) Length Width Height	19-8		23-7 7-4 ²⁵ / ₃₂ 7-6 ⁷ / ₁₆			27-6	31-5	35-4

LEGEND

- Al — Aluminum
- Cu — Copper
- EXV — Electronic Expansion Valve
- N/A — Not Applicable

*Operating weight includes 2 pumps on Models 30RB060-190. No pumps are available on models larger than 30RB190.

Table 2B — Physical Data, 30RB060-300 — SI

UNIT 30RB	060	070	080	090	100	110	120	130	150
OPERATING WEIGHT (kg)*									
Al-Cu Condenser Coil	2134	2228	2385	2989	3090	3206	3737	3898	4449
Cu-Cu Condenser Coil	2353	2446	2604	3318	3419	3534	4120	4335	4887
REFRIGERANT TYPE	R-410A, EXV Controlled System								
Refrigerant Charge (kg)									
Ckt A/Ckt B/Ckt C	40.6/18.4/—	50.8/18.4/—	31.1/31.1/—	43.5/34.5/—	43.5/43.5/—	43.5/48.1/—	43.5/60.3/—	60.3/48.1/—	60.3/60.3/—
COMPRESSORS	Scroll, Hermetic								
Quantity	3	3	4	4	4	5	5	6	6
Speed (r/s)					58.3				
(Qty) Compressor Nominal Capacity (ton) Ckt A	(2) 20	(2) 25	(2) 20	(2) 25	(2) 25	(2) 25	(2) 25	(3) 25	(3) 25
(Qty) Compressor Nominal Capacity (ton) Ckt B	(1) 20	(1) 20	(2) 20	(2) 20	(2) 25	(3) 20	(3) 25	(3) 20	(3) 25
(Qty) Compressor Nominal Capacity (ton) Ckt C	N/A	N/A	N/A	N/A	N/A	N/A	N/A	N/A	N/A
Oil Charge (L, Ckt A/Ckt B/Ckt C)	12.4/6.2/—	12.4/6.2/—	12.4/12.4/—	12.4/12.4/—	12.4/12.4/—	12.4/18.6/—	12.4/18.6/—	18.6/18.6/—	18.6/18.6/—
No. Capacity Steps									
Standard	3	3	4	4	4	5	5	6	6
Optional (Maximum)	4	4	5	5	5	6	6	7	7
Minimum Capacity Step (%)									
Standard	33	29	25	22	25	18	20	15	17
Optional	22	19	16	14	18	12	14	10	12
Capacity (%)									
Ckt A	67	71	50	56	50	45	40	56	50
Ckt B	33	29	50	44	50	55	60	44	50
Ckt C	N/A	N/A	N/A	N/A	N/A	N/A	N/A	N/A	N/A
COOLER	Direct Expansion, Shell and Tube Type								
Weight (empty, kg)	324	324	388	388	388	440	440	440	689
Net Fluid Volume (L)	106	106	118	118	118	173	173	173	278
Maximum Refrigerant Pressure (kPa)	3068	3068	3068	3068	3068	3068	3068	3068	3068
Maximum Fluid Side Pressure Without Pumps (kPa)	2068	2068	2068	2068	2068	2068	2068	2068	2068
Maximum Fluid Side Pressure With Pumps (kPa)	1034	1034	1034	1034	1034	1034	1034	1034	1034
FLUID CONNECTIONS (in.)									
Inlet and Outlet, Victaulic Drain (NPT)	4 3/4	4 3/4	4 3/4	4 3/4	4 3/4	6 3/4	6 3/4	6 3/4	6 3/4
CONDENSER FANS	Shrouded Axial Type, Vertical Discharge								
Standard Low Noise Type									
Fan Speed (r/s) Standard/Low Noise	19	19	19	19	19	19	19	19	19
No. Blades...Diameter (mm)	9...762 3/1/—	9...762 3/1/—	9...762 2/2/—	9...762 3/3/—	9...762 3/3/—	9...762 3/3/—	9...762 3/4/—	9...762 4/4/—	9...762 4/4/—
No. Fans (Ckt A/Ckt B/Ckt C)	3/1/—	3/1/—	2/2/—	3/3/—	3/3/—	3/3/—	3/4/—	4/4/—	4/4/—
Total Airflow (L/s)	23 409	23 409	23 409	35 113	35 113	35 113	40 965	46 817	46 817
CONDENSER COILS	3/4-in. OD, Plate Fin, Enhanced Copper Tubing								
No. Coils (Ckt A/Ckt B/Ckt C)	3/1/—	3/1/—	2/2/—	3/3/—	3/3/—	3/3/—	3/4/—	4/4/—	4/4/—
Total Face Area (sq m)	8.73	8.73	8.73	13.1	13.1	13.1	15.24	17.47	17.47
No. Rows (Ckt A or B or C)	3	3	3	3	3	3	3	3	3
Max Working Refrigeration Pressure (kPa)	4522	4522	4522	4522	4522	4522	4522	4522	4522
HYDRONIC MODULE (Optional)	Pump(s) with pressure/temperature taps and combination valve.								
Pump	Single or Dual, 29.2 or 58.3 r/s								
CHASSIS DIMENSIONS									
Length (mm)	2412			3606			4800		
Width (mm)				2255					
Height (mm)				2296.9					

LEGEND

- Al — Aluminum
- Cu — Copper
- EXV — Electronic Expansion Valve
- N/A — Not Applicable

*Operating weight includes 2 pumps on Models 30RB060-190. No pumps are available on models larger than 30RB190.

Table 2B — Physical Data, 30RB060-300 — SI (cont)

UNIT 30RB	160	170	190	210	225	250	275	300
OPERATING WEIGHT (kg)*								
Al-Cu Condenser Coil	4944	5097	5737	5905	6056	6691	7348	7979
Cu-Cu Condenser Coil	5491	5643	6393	6561	6712	7457	8223	8964
REFRIGERANT TYPE	R-410A, EXV Controlled System							
Refrigerant Charge (kg)								
Ckt A/Ckt B/Ckt C	73.5/48.1/—	73.5/60.3/—	73.5/73.5/—	60.3/48.1/60.3	60.3/60.3/60.3	60.3/60.3/73.5	73.5/73.5/60.3	73.5/73.5/73.5
COMPRESSORS	Scroll, Hermetic							
Quantity	7	7	8	9	9	10	11	12
Speed (r/s)	58.3							
(Qty) Compressor Nominal Capacity (ton) Ckt A	(4) 25	(4) 25	(4) 25	(3) 25	(3) 25	(3) 25	(4) 25	(4) 25
(Qty) Compressor Nominal Capacity (ton) Ckt B	(3) 20	(3) 25	(4) 25	(3) 20	(3) 25	(3) 25	(4) 25	(4) 25
(Qty) Compressor Nominal Capacity (ton) Ckt C	N/A	N/A	N/A	(3) 25	(3) 25	(4) 25	(3) 25	(4) 25
Oil Charge (L, Ckt A/Ckt B/Ckt C)	24.8/18.6/—	24.8/18.6/—	24.8/24.8/—	18.6/18.6/18.6	18.6/18.6/18.6	18.6/18.6/24.8	24.8/24.8/18.6	24.8/24.8/24.8
No. Capacity Steps								
Standard	7	7	8	9	9	10	11	12
Optional (Maximum)	8	8	9	10	10	11	12	13
Minimum Capacity Step (%)								
Standard	13	14	13	10	11	10	9	8
Optional	8	10	9	6	8	7	7	6
Capacity (%)								
Ckt A	62	57	50	38	33	30	36	33
Ckt B	38	43	50	28	33	30	36	33
Ckt C	N/A	N/A	N/A	36	33	40	28	33
COOLER	Direct Expansion, Shell and Tube Type							
Weight (empty, kg)	689	689	689	1080	1080	1080	1080	1080
Net Fluid Volume (L)	278	278	278	327	327	327	327	327
Maximum Refrigerant Pressure (psig)	3068	3068	3068	3068	3068	3068	3068	3068
Maximum Fluid Side Pressure Without Pumps (psig)	2068	2068	2068	2068	2068	2068	2068	2068
Maximum Fluid Side Pressure With Pumps (psig)	1034	1034	1034	1034	1034	1034	1034	1034
FLUID CONNECTIONS (in.)								
Inlet and Outlet, Victaulic	6	6	6	6	6	6	6	6
Drain (NPT)	3/4	3/4	3/4	3/4	3/4	3/4	3/4	3/4
CONDENSER FANS	Shrouded Axial Type, Vertical Discharge							
Standard Low Noise Type								
Fan Speed (r/s) Standard/Low Noise	19	19	19	19	19	19	19	19
No. Blades...Diameter (mm)	9...762	9...762	9...762	9...762	9...762	9...762	9...762	9...762
No. Fans (Ckt A/Ckt B/Ckt C)	6/4/—	6/4/—	6/6/—	4/4/4	4/4/4	4/4/6	6/6/4	6/6/6
Total Airflow (L/s)	58 521	58 521	70 226	70 226	70 226	81 930	93 634	105 339
CONDENSER COILS	3/4-in. OD, Plate Fin, Enhanced Copper Tubing							
No. Coils (Ckt A/Ckt B/Ckt C)	6/4/—	6/4/—	6/6/—	4/4/4	4/4/4	4/4/6	6/6/4	6/6/6
Total Face Area (sq m)	21.83	21.83	26.2	26.2	26.2	30.47	34.84	39.21
No. Rows (Ckt A or B or C)	3	3	3	3	3	3	3	3
Max Working Refrigeration Pressure (kPa)	4522	4522	4522	4522	4522	4522	4522	4522
HYDRONIC MODULE (Optional)	Pump(s) with pressure/temperature taps and combination valve.				Not available			
Pump	Single or Dual, 29.2 or 58.3 r/s				Not available			
CHASSIS DIMENSIONS								
Length (mm)	5994	5994	7188	7188	7188	8382	9576	10 770
Width (mm)					2255			
Height (mm)					2296.9			

LEGEND

- Al — Aluminum
- Cu — Copper
- EXV — Electronic Expansion Valve
- N/A — Not Applicable

*Operating weight includes 2 pumps on Models 30RB060-190. No pumps are available on models larger than 30RB190.

Table 3A — Physical Data — 30RB315-390 — English

UNIT 30RB	315	330	345	360	390
OPERATING WEIGHT (Module A/Module B, lb)*					
Cu-Al Condenser Coil	10,900/10,900	11,235/10,900	11,235/11,235	12,647/11,235	12,647/12,657
Cu-Cu Condenser Coil	12,106/12,106	12,441/12,106	12,441/12,441	14,094/12,441	14,094/14,094
REFRIGERANT TYPE	R-410A, EXV Controlled System				
Circuits Qty	4	4	4	4	4
Refrigerant Charge					
Module A Ckt A/Ckt B (lb)	162/106	162/133	162/133	162/162	162/162
Module B Ckt A/Ckt B (lb)	162/106	162/106	162/133	162/133	162/162
COMPRESSORS	Scroll, Hermetic				
Total Quantity	14	14	14	15	16
Speed (rpm)			3500		
Module A, (Qty) Compressor Nominal Capacity (ton) Ckt A	(4) 25	(4) 25	(4) 25	(4) 25	(4) 25
Module A, (Qty) Compressor Nominal Capacity (ton) Ckt B	(3) 20	(3) 25	(3) 25	(4) 25	(4) 25
Module B, (Qty) Compressor Nominal Capacity (ton) Ckt A	(4) 25	(4) 25	(4) 25	(4) 25	(4) 25
Module B, (Qty) Compressor Nominal Capacity (ton) Ckt B	(3) 20	(3) 20	(3) 25	(3) 25	(4) 25
Module A Oil Charge (Pt, Ckt A/Ckt B)	52.5/39.4	52.5/39.4	52.5/39.4	52.5/52.5	52.5/52.5
Module B Oil Charge (Pt, Ckt A/Ckt B)	52.5/39.4	52.5/39.4	52.5/39.4	52.5/39.4	52.5/52.5
No. Capacity Steps					
Standard	14	14	14	15	16
Optional (Maximum)	16	16	16	17	18
Minimum Capacity Step (%)					
Standard	6	6	7	7	6
Optional	5	4	6	5	5
Capacity (%)					
Module A, Ckt A	31	30	29	27	25
Module A, Ckt B	19	22	21	27	25
Module B, Ckt A	31	30	29	27	25
Module B, Ckt B	19	18	21	20	25
COOLER	Direct Expansion, Shell and Tube Type				
Module A Weight (empty, lb)	1518	1518	1518	1518	1518
Module B Weight (empty, lb)	1518	1518	1518	1518	1518
Net Fluid Volume (gal) Module A/Module B	73.5/73.5	73.5/73.5	73.5/73.5	73.5/73.5	73.5/73.5
Maximum Refrigerant Pressure (psig)	445	445	445	445	445
Maximum Fluid Side Pressure (psig)	300	300	300	300	300
FLUID CONNECTIONS (in.)					
Inlet and Outlet, Victaulic	6	6	6	6	6
Drain (NPT)	3/4	3/4	3/4	3/4	3/4
CONDENSER FANS	Shrouded Axial Type, Vertical Discharge				
Standard Low Noise Type					
Fan Speed (rpm) Standard/Low Noise	1140	1140	1140	1140	1140
Module A No. Blades...Diameter (in.) Ckt A/Ckt B	9...30/9...30	9...30/9...30	9...30/9...30	9...30/9...30	9...30/9...30
Module B No. Blades...Diameter (in.) Ckt A/Ckt B	9...30/9...30	9...30/9...30	9...30/9...30	9...30/9...30	9...30/9...30
Total No. Fans	20	20	20	22	24
Module A No. Fans (Ckt A/Ckt B)	6/4	6/4	6/4	6/6	6/6
Module B No. Fans (Ckt A/Ckt B)	6/4	6/4	6/4	6/4	6/6
Total Airflow (cfm)	248,000	248,000	248,000	272,800	297,600
CONDENSER COILS	3/4-in. OD, Plate Fin, Enhanced Copper Tubing				
Module A No. Coils (Ckt A/Ckt B)	6/4	6/4	6/4	6/6	6/6
Module B No. Coils (Ckt A/Ckt B)	6/4	6/4	6/4	6/4	6/6
Total Face Area (sq ft)	470	470	470	517	564
No. Rows (Ckt A or B, any module)	3	3	3	3	3
Max Working Refrigerant Pressure (psig)	656	656	656	656	656

LEGEND

- Al — Aluminum
- Cu — Copper
- EXV — Electronic Expansion Valve

*No pumps are available for models 30RB315-390.

Table 3B — Physical Data — 30RB315-390 — SI

UNIT 30RB	315	330	345	360	390
OPERATING WEIGHT (Module A/Module B, kg)*					
Cu-Al Condenser Coil	4944/4944	5096/4944	5096/5096	5737/5096	5737/5737
Cu-Cu Condenser Coil	5491/5491	5643/5491	5643/5643	6393/5643	6393/6393
REFRIGERANT TYPE	R-410A, EXV Controlled System				
Circuits Qty	4	4	4	4	4
Refrigerant Charge					
Module A Ckt A/Ckt B (kg)	73.5/48.1	73.5/60.3	73.5/60.3	73.5/73.5	73.5/73.5
Module B Ckt A/Ckt B (kg)	73.5/48.1	73.5/48.1	73.5/60.3	73.5/60.3	73.5/73.5
COMPRESSORS	Scroll, Hermetic				
Total Quantity	14	14	14	15	16
Speed (r/s)			58.3		
Module A, (Qty) Compressor Nominal Capacity (ton) Ckt A	(4) 25	(4) 25	(4) 25	(4) 25	(4) 25
Module A, (Qty) Compressor Nominal Capacity (ton) Ckt B	(3) 20	(3) 25	(3) 25	(4) 25	(4) 25
Module B, (Qty) Compressor Nominal Capacity (ton) Ckt A	(4) 25	(4) 25	(4) 25	(4) 25	(4) 25
Module B, (Qty) Compressor Nominal Capacity (ton) Ckt B	(3) 20	(3) 20	(3) 25	(3) 25	(4) 25
Module A Oil Charge (L, CktA/CktB)	52.5/39.4	52.5/39.4	52.5/39.4	52.5/52.5	52.5/52.5
Module B Oil Charge (L, CktA/CktB)	52.5/39.4	52.5/39.4	52.5/39.4	52.5/39.4	52.5/52.5
No. Capacity Steps					
Standard	14	14	14	15	16
Optional (Maximum)	16	16	16	17	18
Minimum Capacity Step (%)					
Standard	6	6	7	7	6
Optional	5	4	6	5	5
Capacity (%)					
Module A, Ckt A	31	30	29	27	25
Module A, Ckt B	19	22	21	27	25
Module B, Ckt A	31	30	29	27	25
Module B, Ckt B	19	18	21	20	25
COOLER	Direct Expansion, Shell and Tube Type				
Module A Weight (empty, kg)	689	689	689	689	689
Module B Weight (empty, kg)	689	689	689	689	689
Net Fluid Volume (L) Module A/Module B	278/278	278/278	278/278	278/278	278/278
Maximum Refrigerant Pressure (kPa)	3068	3068	3068	3068	3068
Maximum Fluid Side Pressure (kPa)	2068	2068	2068	2068	2068
FLUID CONNECTIONS (in.)					
Inlet and Outlet, Victaulic	6	6	6	6	6
Drain (NPT)	3/4	3/4	3/4	3/4	3/4
CONDENSER FANS	Shrouded Axial Type, Vertical Discharge				
Standard Low Noise Type					
Fan Speed (r/s) Standard/Low Noise	19	19	19	19	19
Module A No. Blades...Diameter (mm.) Ckt A/Ckt B	9...762/9...762	9...762/9...762	9...762/9...762	9...762/9...762	9...762/9...762
Module B No. Blades...Diameter (mm.) Ckt A/Ckt B	9...762/9...762	9...762/9...762	9...762/9...762	9...762/9...762	9...762/9...762
Total No. Fans	20	20	20	22	24
Module A No. Fans (Ckt A/Ckt B)	6/4	6/4	6/4	6/6	6/6
Module B No. Fans (Ckt A/Ckt B)	6/4	6/4	6/4	6/4	6/6
Total Airflow (L/s)	117 042	117 042	117 042	128 747	140 452
CONDENSER COILS	3/4-in. OD, Plate Fin, Enhanced Copper Tubing				
Module A No. Coils (Ckt A/Ckt B)	6/4	6/4	6/4	6/6	6/6
Module B No. Coils (Ckt A/Ckt B)	6/4	6/4	6/4	6/4	6/6
Total Face Area (sq m)	43.66	43.66	43.66	48.03	52.4
NO. Rows (Ckt A or B, any module)	3	3	3	3	3
Max Working Refrigerant Pressure (kPa)	4522	4522	4522	4522	4522

LEGEND

- Al — Aluminum
- Cu — Copper
- EXV — Electronic Expansion Valve

*No pumps are available for models 30RB315-390.

INSTALLATION

Storage — If the unit is to be stored for a period of time before installation or start-up, be sure to protect the machine from construction dirt and moisture. Keep protective shipping covers in place until machine is ready for installation.

Step 1 — Place, Rig and Mount the Unit

PLACING UNIT — Locate the unit so that the condenser airflow is unrestricted both above and on the sides of the unit. Air flow and service clearances are 6 feet (1.8 m) around the unit. Acceptable clearance on the cooler connection side or end opposite the control box unit can be reduced to 3 feet (1 m) without sacrificing performance as long as the remaining three sides are unrestricted. Acceptable clearance on the side with a control box can be reduced to 4 feet (1.3 m) due to NEC regulations, without sacrificing performance as long as the remaining three sides are unrestricted. Provide ample room for servicing and removing cooler. See Fig. 2-13 for required clearances. Local codes for clearances take precedent over the manufacturer's recommendations when local codes call for greater clearances.

Modular units, 30RB315-390 must be installed with a minimum separation end to end of 4 feet (1.3 m) for airflow and service clearance along with NEC regulations.

If multiple units are installed at the same site, a separation of 10 feet (3 m) between the sides of the machines is required to maintain proper airflow and minimize the chances of condenser air recirculation.

MOUNTING UNIT — The unit may be mounted on a level pad directly on the base rails, on a raised perimeter rail around the unit, or on vibration isolation springs. For all units, ensure placement area is strong enough to support unit operating weight. Mounting holes are provided for securing the unit to the pad, perimeter rail or vibration isolation springs. Bolt the unit securely to pad or rails. If vibration isolators (field-supplied) are required for a particular installation, refer to unit weight distribution in Fig. 14 to aid in the proper selection of isolators. The 30RB units can be mounted directly on spring isolators. For each unit or module, the final unit location must be level so that oil will equalize properly.

RIGGING UNIT — The 30RB060-390 units are designed for overhead rigging and it is important that this method be used. Holes are provided in frame base channels, marked for rigging (see rigging label on unit). It is recommended that field-supplied shackles be used to facilitate lifting. Secure the shackles to the base rails at the points noted on the rigging label. See Table 4 for the number of lifting points for each unit.

Do not use a forklift truck to move the units.

Table 4 — Number of Lifting Points for 30RB060-390

30RB	NUMBER OF LIFTING POINTS
060-150	4
160, 170	6
190-300	8
315A, 315B, 330A, 330B, 345A, 345B, 360A	6
360B, 390A, 390B	8

Use spreader bars to keep cables or chains clear of unit sides. As further protection plywood sheets may be placed against sides of unit, behind cables or chains. Run cables or chains to a central suspension point so that angle from horizontal is not less than 45 degrees. Raise and set unit down carefully. See Fig. 15 and 16 for rigging centers of gravity.

Each module of the 30RB315-390 units must be rigged separately. When placing unit modules for unit sizes 315-390, make sure modules are placed to permit access to the control boxes for each module.

For shipping, some domestic units and all export units are mounted on a wooden skid under entire base of unit. Skid can be removed before unit is moved to installation site. Lift the unit from above to remove skid. See Fig. 15 and 16 for rigging center of gravity. On export units, the top skid can be used as the spreader bars. If the unit was shipped with a shipping bag, the bag must be removed to gain access to the rigging holes in the base rail. On export units with a full crate, the crate sides must be removed to aid in rigging.

If overhead rigging is not available, the unit can be moved on rollers or dragged. When unit is moved on rollers, the unit skid, if equipped, must be removed. To lift the unit, use jacks at the rigging points. Use a minimum number of rollers to distribute the load such that the rollers are no more than 6 feet (1.8 m) apart. If the unit is to be dragged, lift the unit as described above, and place unit on a pad. Apply moving force to the pad, and not the unit. When in its final location, raise the unit and remove the pad.

If the unit was shipped with coil protection, it must be removed before start-up. The shipping bag for export units must be removed before start-up.

NOTE: If the application includes a remote-mounted cooler option, follow the instructions included with the accessory for cooler placement and refrigerant piping.

Step 2 — Remove Compressor Rack Holddown Bolts

— The 30RB units are shipped with holddown bolts securing the compressor rail assembly to the unit base frame. These bolts are located between the compressors in the front and rear of the compressor rail assembly. These bolts and hold-down assemblies must be removed for the vibration isolation system to operate properly. Loosen and remove the bolt and collar assembly as shown in Fig. 17.

See Table 5 for the number of holddown assemblies for each unit.

Isolation mounts for the compressor rail assembly are located directly in front of and behind each compressor. Do not loosen or remove the isolation mounts, only the shipping bolts. There are 4 bolts that hold down each compressor. Do not loosen these bolts.

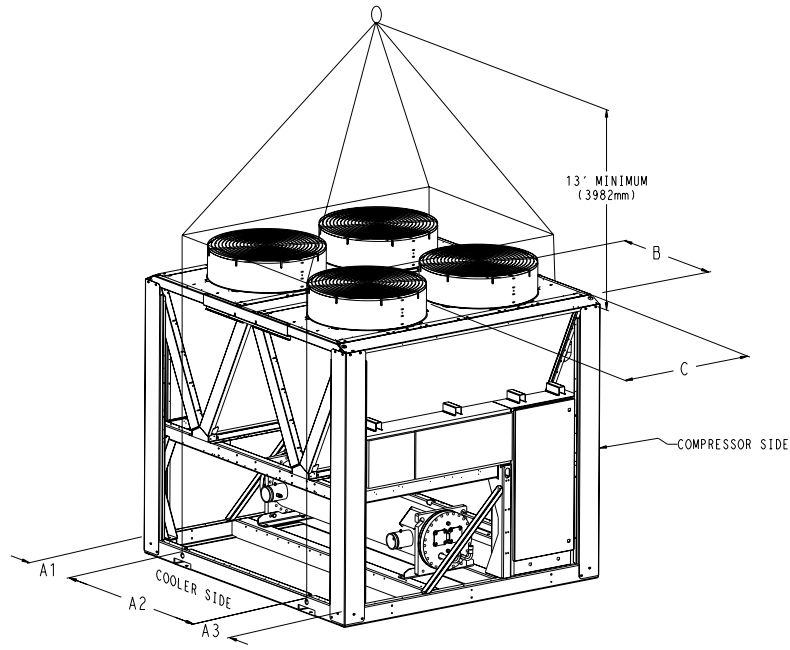

CAUTION- NOTICE TO RIGGERS:

ALL PANELS MUST BE IN PLACE WHEN RIGGING. DO NOT ATTEMPT TO FORK THESE UNITS IF NO SKID IS SUPPLIED.

NOTES:

1. 1.50 DIA. (38.1mm) LIFTING HOLES PROVIDED FOR FIELD SUPPLIED CLEVIS.
2. RIG WITH A MINIMUM OF 25FT (7620MM) LENGTH CHAINS OR CABLES.
3. IF CENTRAL LIFTING POINT IS USED, IT MUST BE A MINIMUM OF 13 FT. (3962mm) ABOVE THE TOP OF THE UNIT.
4. SPREADER BARS MADE FROM STEEL OR DOUBLE NAILED, AND NOTCHED 2X6'S APPROXIMATELY 8FT. (2438mm) LONG, MUST BE PLACED JUST ABOVE THE TOP OF THE UNIT (AND STACKS) TO REDUCE THE RISK OF DAMAGE TO THE TOP OF THE UNIT AND COILS.
5. IF OVERHEAD RIGGING IS NOT AVAILABLE, THE UNIT CAN BE MOVED ON ROLLERS OR DRAGGED. WHEN UNIT IS MOVED ON ROLLERS, THE UNIT SKID, IF EQUIPPED, MUST BE REMOVED. TO LIFT THE UNIT, USE JACKS AT THE RIGGING POINTS. USE A MINIMUM OF ONE ROLLER EVERY 6FT. (1829mm) TO DISTRIBUTE THE LOAD. IF THE UNIT IS TO BE DRAGGED, LIFT THE UNIT AS DESCRIBED ABOVE, AND PLACE UNIT ON A PAD. APPLY MOVING FORCE TO THE PAD, NOT THE UNIT. WHEN IN ITS FINAL LOCATION, RAISE THE UNIT AND REMOVE THE PAD.
6. CHECK BILL OF LADING FOR SHIPPING WEIGHT OF UNIT.

MODEL NUMBER	MAX. SHIPPING WT. W/O PACKAGING		MAX. SHIPPING WT. WITH PACKAGING		LIFTING HOLES						CENTER OF GRAVITY			
					"A1"		"A2"		"A3"		"B"		"C"	
	LB	KG	LB	KG	IN.	MM	IN.	MM	IN.	MM	IN.	MM	IN.	MM
30RBA060	4705	2134	5685	2579	18.0	456.6	58.3	1479.8	18.0	456.6	45.8	1164.3	40.9	1037.9
30RBA060-CU	5187	2353	6167	2797	18.0	456.6	58.3	1479.8	18.0	456.6	45.8	1164.3	40.9	1037.9
30RBA070	4911	2228	5891	2672	18.0	456.6	58.3	1479.8	18.0	456.6	45.9	1164.8	39.9	1012.7
30RBA070-CU	5393	2446	6373	2891	18.0	456.6	58.3	1479.8	18.0	456.6	45.9	1164.8	39.9	1012.7
30RBA080	5258	2385	6238	2830	18.0	456.6	58.3	1479.8	18.0	456.6	47.5	1205.7	39.8	1012.2
30RBA080-CU	5740	2604	6720	3048	18.0	456.6	58.3	1479.8	18.0	456.6	47.5	1205.7	39.8	1012.2
30RBA090	6590	2989	7660	3475	16.1	408.9	109.0	2769.3	16.1	408.9	64.0	1624.8	40.1	1017.4
30RBA090-CU	7314	3318	8384	3803	16.1	408.9	109.0	2769.3	16.1	408.9	64.0	1624.8	40.1	1017.4
30RBA100	6813	3090	7883	3576	16.1	408.9	109.0	2769.3	16.1	408.9	63.5	1614.0	39.3	998.5
30RBA100-CU	7537	3419	8607	3904	16.1	408.9	109.0	2769.3	16.1	408.9	63.5	1614.0	39.3	998.5
30RBA110	7067	3206	8137	3691	16.1	408.9	109.0	2769.3	16.1	408.9	67.4	1713.0	39.3	997.1
30RBA110-CU	7791	3534	8861	4019	16.1	408.9	109.0	2769.3	16.1	408.9	67.4	1713.0	39.3	997.1
30RBA120	8238	3737	9398	4263	16.1	408.9	156.0	3963.3	16.1	408.9	92.3	2345.5	39.1	992.7
30RBA120-CU	9082	4120	10242	4646	16.1	408.9	156.0	3963.3	16.1	408.9	92.3	2345.5	39.1	992.7
30RBA130	8593	3898	9753	4424	16.1	408.9	156.0	3963.3	16.1	408.9	89.5	2272.4	38.7	983.2
30RBA130-CU	9558	4336	10718	4862	16.1	408.9	156.0	3963.3	16.1	408.9	89.5	2272.4	38.7	983.2
30RBA150	9808	4449	10968	4975	16.1	408.9	156.0	3963.3	16.1	408.9	94.2	2392.2	38.7	982.8
30RBA150-CU	10773	4887	11933	5413	16.1	408.9	156.0	3963.3	16.1	408.9	94.2	2392.2	38.7	982.8
DEDUCT THESE VALUES FOR UNITS WITH NO PUMP OPTIONS														
	SINGLE PUMP DEDUCT (LB)		NO PUMP DEDUCT (LB)				SINGLE PUMP DEDUCT (LB)		NO PUMP DEDUCT (LB)					
30RBA060,070	318		833				383		923					
30RBA080-100	423		923				592		1245					
CU = COPPER FINNED COILS											00PSN500037300A			

Fig. 15 — Unit Rigging Label Detail 30RB060-150

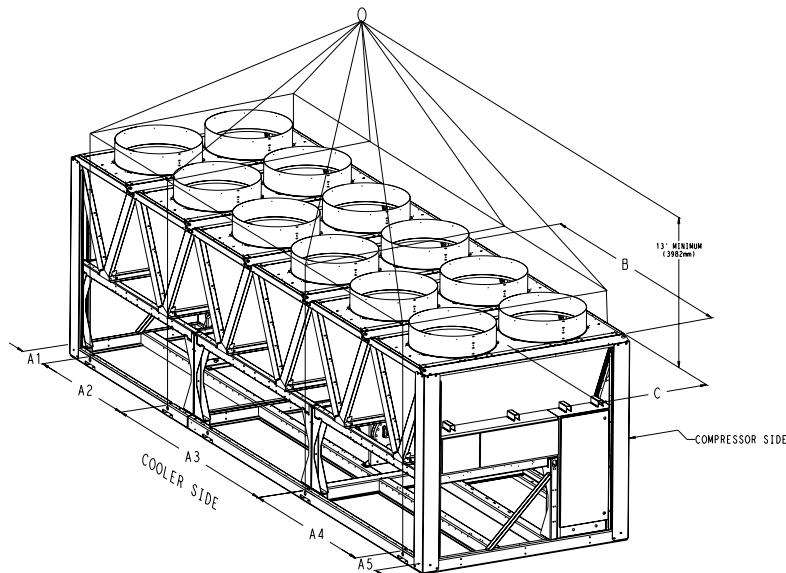

CAUTION- NOTICE TO RIGGERS:
 ALL PANELS MUST BE IN PLACE WHEN RIGGING. DO NOT ATTEMPT TO FORK THESE UNITS IF NO SKID IS SUPPLIED.

NOTES:

1. 50 DIA. (38.1mm) LIFTING HOLES PROVIDED FOR FIELD SUPPLIED CLEVIS.
2. RIG WITH A MINIMUM OF 25FT (7620MM) LENGTH CHAINS OR CABLES.
3. IF CENTRAL LIFTING POINT IS USED, IT MUST BE A MINIMUM OF 13 FT. (3962mm) ABOVE THE TOP OF THE UNIT.
4. SPREADER BARS MADE FROM STEEL OR DOUBLE NAILED, AND NOTCHED 246"± APPROXIMATELY 8FT. (2438mm) LONG, MUST BE PLACED JUST ABOVE THE TOP OF THE UNIT (AND STACKS) TO REDUCE THE RISK OF DAMAGE TO THE TOP OF THE UNIT AND COILS.
5. IF OVERHEAD RIGGING IS NOT AVAILABLE, THE UNIT CAN BE MOVED ON ROLLERS OR DRAGGED. WHEN UNIT IS MOVED ON ROLLERS, THE UNIT SKID, IF EQUIPPED, MUST BE REMOVED. TO LIFT THE UNIT, USE JACKS AT THE RIGGING POINTS. USE A MINIMUM OF ONE ROLLER EVERY 6FT. (1829mm) TO DISTRIBUTE THE LOAD. IF THE UNITS TO BE DRAGGED, LIFT THE UNIT AS DESCRIBED ABOVE, AND PLACE UNIT ON A PAD. APPLY MOVING FORCE TO THE PAD, NOT THE UNIT. WHEN IN ITS FINAL LOCATION, RAISE THE UNIT AND REMOVE THE PAD.
6. CHECK BILL OF LADING FOR SHIPPING WEIGHT OF UNIT.

MODEL NUMBER	MAX. SHIPPING WT. W/O PACKAGING		MAX. SHIPPING WT. WITH PACKAGING		LIFTING HOLES										CENTER OF GRAVITY			
					"A1"		"A2"		"A3"		"A4"		"A5"		"B"		"C"	
	LB	KG	LB	KG	IN.	MM	IN.	MM	IN.	MM	IN.	MM	IN.	MM	IN.	MM	IN.	MM
30RBA160	10900	4944	12150	5511	16.1	408.9	94.0	2388.0	109.0	2769.3	16.1	408.9	N/A	N/A	120.7	3064.9	39.1	994.4
30RBA160-CU	12106	5491	13356	6058	16.1	408.9	94.0	2388.0	109.0	2769.3	16.1	408.9	N/A	N/A	120.7	3064.9	39.1	994.4
30RBA170	11235	5096	12485	5663	16.1	408.9	94.0	2388.0	109.0	2769.3	16.1	408.9	N/A	N/A	122.6	3113.6	38.5	978.1
30RBA170-CU	12441	5643	13691	6210	16.1	408.9	94.0	2388.0	109.0	2769.3	16.1	408.9	N/A	N/A	122.6	3113.6	38.5	978.1
30RBA190	12647	5737	13987	6345	16.1	408.9	109.0	2769.3	32.0	812.7	109.0	2769.3	16.1	408.9	94.0	2388.0	38.4	974.3
30RBA190-CU	14094	6393	15434	7001	16.1	408.9	109.0	2769.3	32.0	812.7	109.0	2769.3	16.1	408.9	94.0	2388.0	38.4	974.3
30RBA210	13018	5905	14358	6513	16.1	408.9	62.0	1575.3	110.0	2794.4	78.0	1981.7	16.1	408.9	38.9	982.7	36.1	917.5
30RBA210-CU	14465	6561	15805	7169	16.1	408.9	62.0	1575.3	110.0	2794.4	78.0	1981.7	16.1	408.9	38.9	982.7	36.1	917.5
30RBA225	13351	6056	14691	6664	16.1	408.9	62.0	1575.3	110.0	2794.4	78.0	1981.7	16.1	408.9	41.3	3588.4	35.7	906.4
30RBA225-CU	14798	6712	16138	7320	16.1	408.9	62.0	1575.3	110.0	2794.4	78.0	1981.7	16.1	408.9	41.3	3588.4	35.7	906.4
30RBA250	14752	6691	16182	7340	16.1	408.9	109.0	2769.3	110.0	2794.4	78.0	1981.7	16.1	408.9	58.3	4021.7	35.8	910.1
30RBA250-CU	16441	7457	17871	8106	16.1	408.9	109.0	2769.3	110.0	2794.4	78.0	1981.7	16.1	408.9	58.3	4021.7	35.8	910.1
30RBA275	16199	7348	17719	8037	16.1	408.9	62.0	1575.3	141.0	3582.0	141.0	3582.0	16.1	408.9	91.2	4856.9	36.0	913.8
30RBA275-CU	18129	8223	19649	8913	16.1	408.9	62.0	1575.3	141.0	3582.0	141.0	3582.0	16.1	408.9	91.2	4856.9	36.0	913.8
30RBA300	17590	7979	19200	8709	16.1	408.9	109.0	2769.3	141.0	3582.0	141.0	3582.0	16.1	408.9	209.3	5316.8	36.0	915.6
30RBA300-CU	19761	8964	21371	9694	16.1	408.9	109.0	2769.3	141.0	3582.0	141.0	3582.0	16.1	408.9	209.3	5316.8	36.0	915.6

DEDUCT THESE VALUES FOR UNITS WITH NO PUMP OPTIONS

	SINGLE PUMP DEDUCT (LB)	NO PUMP DEDUCT (LB)
30RBA160-190	592	1245

CU = COPPER FINNED COILS 00PSN500037400A

Fig. 16 — Unit Rigging Label Detail 30RB160-300

Table 5 — Number of Holddown Assemblies

UNIT 30RB	CIRCUIT A	CIRCUIT B	CIRCUIT C			
060-070	4	4	—			
080-100	4	4	—			
110-120	2	4	—			
130-190	4	4	—			
210-300	4	4	4			
Modular Units	Module A	Module B	Module A	Module B	Module A	Module B
315	4	4	4	4	—	—
330	4	4	4	4	—	—
345	4	4	4	4	—	—
360	4	4	4	4	—	—
390	4	4	4	4	—	—

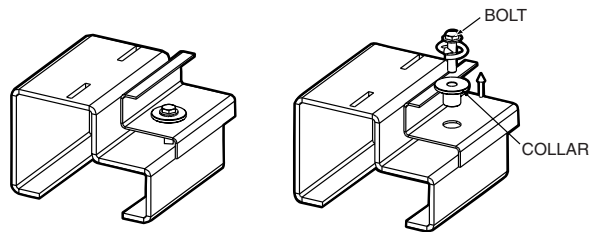

Fig. 17 — Compressor Rack Holddown Bolts

Step 3 — Cooler Fluid and Drain Piping Connections — The 30RB units are supplied with a factory-installed flow switch in the leaving water (fluid) piping. Flow switch wiring is factory installed.

To facilitate servicing it is recommended additional field-supplied air vents be installed to facilitate servicing. Locate air vents at the highest possible point of the chilled water system. In addition to field-supplied air vents, facilitate servicing in addition to flow balancing by installing field-supplied shut-off valves, thermometers, clean-out tees, pressure and temperature taps in the inlet and outlet piping. Locate valves in return and supply cooler water lines as close to the chiller as possible.

In sound sensitive applications, consider the installation of piping vibration isolators.

FREEZE PROTECTION — Upon completion of the field piping installation, freeze protection must be considered. Freeze protection for the cooler is available from the factory with a freeze protection option for the unit. Freeze protection for the pump (hydronic) package is standard on all units with the optional hydronic package (30RB060-190 units). External piping freeze protection also must be considered. Since power is sometimes lost for extended periods during winter storms, freeze protection provided by heater tapes will be effective only if a back-up power supply can be assured for the unit's control circuit, heater and cooler pump. If not protected with an antifreeze solution, draining the cooler and outdoor piping is recommended if the system will not be used during freezing weather conditions.

NOTE: See page 39 for a more detailed overview of freeze protection.

IMPORTANT: Glycol anti-freeze solutions are highly recommended since heater tapes provide no protection in the event of a power failure

UNITS WITH HYDRONIC PUMP PACKAGE — The 30RB060-190 units can be equipped with a factory-installed hydronic pump package consisting of a suction guide/strainer, pump, combination valve, internal piping and wiring connected at the factory.

The combination valve performs the following functions:

- Drip-tight shut-off valve
- Spring closure design with a non-slam check valve
- Flow-throttling valve

When facing the cooler side of unit, the inlet (return) water connection is on the right. The outlet (supply) water connection is on the left. The inlet is connected to the suction guide/strainer of the pump via a Victaulic-type connection. The cooler supply has water-side Victaulic-type connections (follow connection directions as provided by the coupling manufacturer). Provide proper support for the piping. If compressor and cooler grilles have been added, holes must be cut in the grilles for field piping and insulation.

The suction guide/strainer is shipped from the factory with a run-in screen. This screen is a temporary device used during the start-up/clean-up process of the chilled water circuit to prevent construction debris from damaging the pump or internal tubes of cooler. After all debris has been removed or a maximum of 24 running hours the temporary screen must be removed. See the Start-Up, Controls, Operation and Troubleshooting guide for further information.

▲ CAUTION

The suction guide/strainer is shipped from the factory with a run-in screen. This temporary screen must be removed after all debris has been removed or a maximum of 24 running hours. Failure to remove the temporary screen may result in damage to the pump or cooler.

NOTE: It is required that a 20 mesh field-supplied strainer be installed in the inlet piping to the cooler on open loop systems.

A 3/4 in. NPT fitting is installed in the inlet piping of the pump for connection to an expansion tank. Install the tank in accordance with the manufacturer's instructions.

Figures 18 and 19 illustrate typical single and dual pump packages.

Three drain connections are provided and are located at leaving water (supply) end of cooler, pump volute, and the suction guide. See Fig. 2-13 for connection location. Insulate the drain piping (in the same manner as the chilled water piping) for at least 1 ft (305 mm) from the cooler.

UNITS WITHOUT HYDRONIC PUMP PACKAGE — When facing the cooler side of the unit, the inlet (return) water connection is on the right. It is required that a field-supplied strainer with a minimum size of 20 mesh be installed ahead of the cooler inlet to prevent debris from damaging internal tubes of the cooler. The outlet (supply) water connection is on the left. The cooler has water-side victaulic-type connections (follow connection directions as provided by the coupling manufacturer). Provide proper support for the piping. If compressor and cooler grilles have been added, holes must be cut in the grilles for field piping and insulation. See Fig. 20 for a typical piping diagram of a 30RB unit without a hydronic pump package.

A drain connection is located at the leaving water (supply) end of cooler. See Fig. 2-13 for connection location. Insulate the drain piping (in the same manner as the chilled water piping) for at least 12 in. (305 mm) from the unit.

FOR ALL UNITS

Dual Chiller Leaving Water Sensor — If the Dual Chiller algorithm is used, and the machines are installed in parallel, a dual chilled water sensor must be installed for each module. For 30RB315-390, a factory-supplied thermistor and well are shipped in the control box of each module. Install the well in the common leaving water header. See Fig. 21.

See page 41 for more dual chiller leaving water sensor information.

Minimum Loop Volume — The preferred minimum loop volume is dependent on the type of application. In order to obtain leaving water temperature stability for comfort cooling applications, a minimum of 3 gallons per ton (3.25 liters per kW) is required on all unit sizes. For process cooling applications, applications where high stability is critical, or operation at ambient temperatures below 32 F (0° C) is expected, the loop volume should be increased to 6 to 10 gallons per ton (6.46 to 10.76 liters per kW) of cooling.

In order to achieve this volume, it may be necessary to add a water storage tank to the water loop. If a storage tank is added to the system, it should be properly vented so that the tank can be completely filled and all air eliminated. Failure to do so could cause lack of pump stability and poor system operation. Any storage tank that is placed in the water loop should have internal baffles to allow thorough mixing of the fluid. See Fig. 22.

System Piping — Proper system design and installation procedures should be followed closely. The system must be constructed with pressure tight components and thoroughly tested for installation leaks. Factory-supplied hydronic systems are available with single or dual (for back-up) pumps. The factory-installed system includes all of the components above the line in Fig. 18 and 19.

Installation of water systems should follow sound engineering practice as well as applicable local and industry standards. Improperly designed or installed systems may cause unsatisfactory operation and/or system failure. Consult a water treatment specialist or appropriate literature for information regarding filtration, water treatment, and control devices. Figure 18 shows a typical installation with components that might be installed with the hydronic package of the 30RB unit.

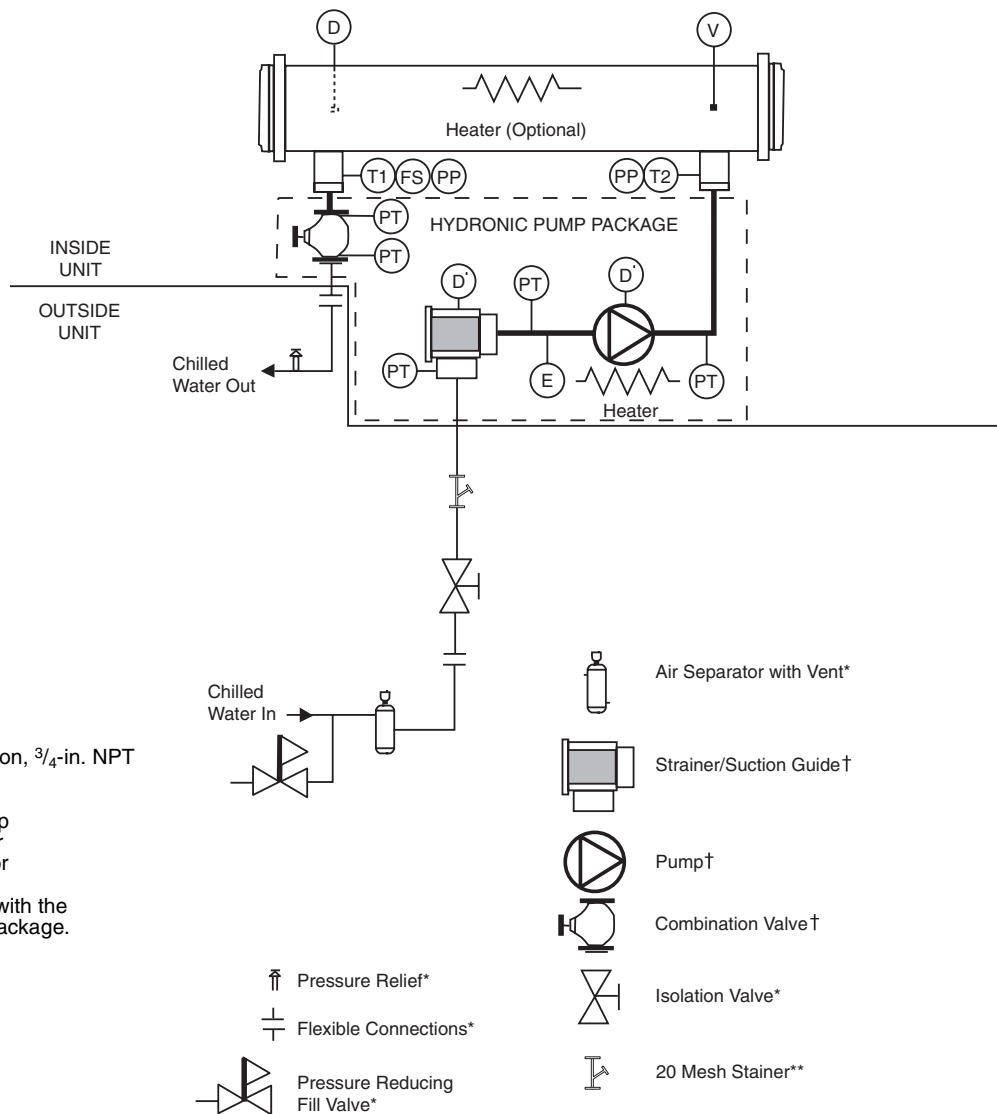

Fig. 18 — Typical Piping Diagram on 30RB Units with Hydronic Package — Single Pump

NOTE: It is recommended for units with the hydronic package that an inlet isolation (shut-off) valve be placed exterior to the unit to allow removal and service of the entire pump assembly, if necessary. The hydronic package is supplied from the factory with a combination valve for isolation of leaving water. Also, if the unit is isolated with valves, a properly sized pressure relief valve is recommended and should be installed in the piping between the unit and the valves, following all applicable local codes.

Air Separation — For proper system operation, it is essential that water loops be installed with proper means to manage air in the system. Free air in the system can cause noise, reduce terminal output, stop flow, or even cause pump failure due to pump cavitation. For closed systems, equipment should be provided to eliminate all air from the system.

The amount of air that water can hold in solution depends on the pressure and temperature of the water/air mixture. Air is less soluble at higher temperatures and at lower pressures. Therefore, separation can best be done at the point of highest water temperature and lowest pressure. Typically, this point would be on the suction side of the pump as the water is returning from the system or terminals. This is generally the optimal place to install an air separator, if possible.

1. Install automatic air vents at all high points in the system. (If the 30RB unit is located at the high point of the system,

a vent can be installed on the piping leaving the heat exchanger on the 1/4 in. NPT female port.)

2. Install an air separator in the water loop, at the place where the water is at higher temperatures and lower pressures — usually in the chilled water return piping. On a primary-secondary system, the highest temperature water is normally in the secondary loop, close to the decoupler. Preference should be given to that point on the system (see Fig. 23. In-line or centrifugal air separators are readily available in the field.

It may not be possible to install air separators at the place of the highest temperature and lowest pressure. In such cases, preference should be given to the points of highest temperature. It is important that the pipe be sized correctly so that free air can be moved to the point of separation. Generally, a water velocity of at least 2 feet per second (.6 m per second) will keep free air entrained and prevent it from forming air pockets.

Automatic vents should be installed at all physically elevated points in the system so that air can be eliminated during system operation. Provisions should also be made for manual venting during the water loop fill.

IMPORTANT: Automatic vents should be located in accessible locations for maintenance purposes and protected from freezing.

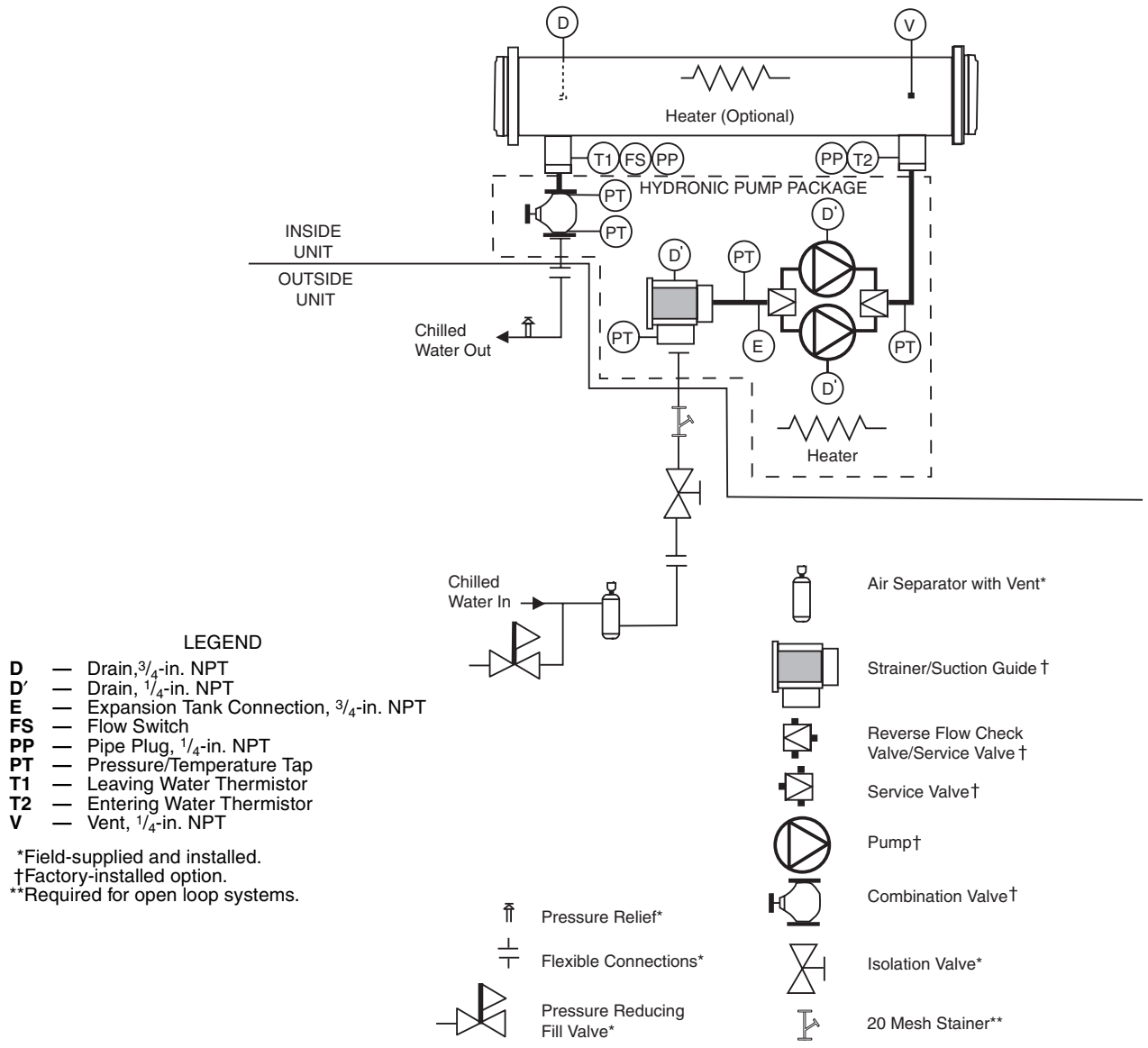

Fig. 19 — Typical Piping Diagram on 30RB Units with Hydronic Package — Dual Pumps

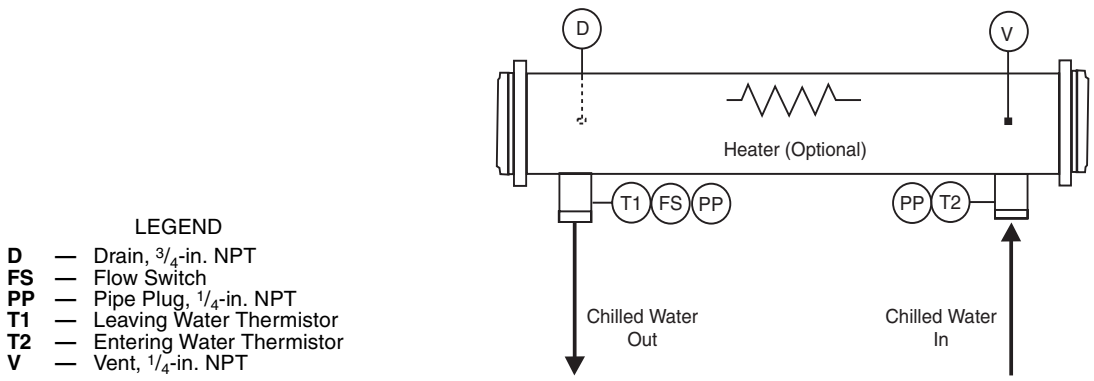
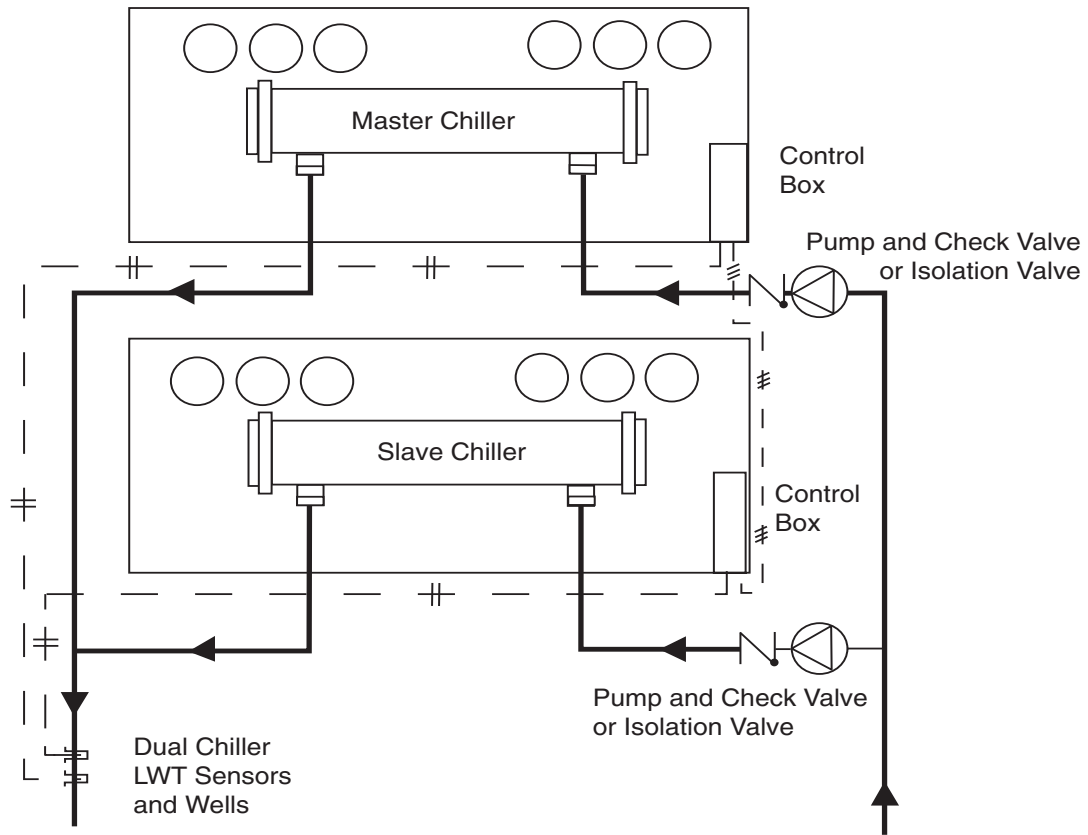

Fig. 20 — Typical Piping Diagram on 30RB Units without Hydronic Package



LEGEND

- LWT** — Leaving Water (fluid) Temperature
- # - Field Wiring
- - # - Field Communication Wiring

NOTE: This is a simplified piping diagram — not all hydronic specialties are shown.

Fig. 21 — Dual Chiller Thermister Location

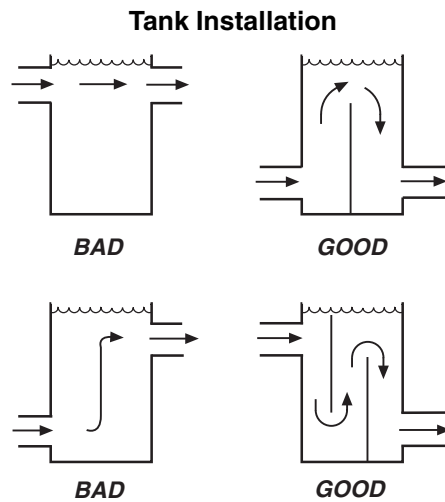
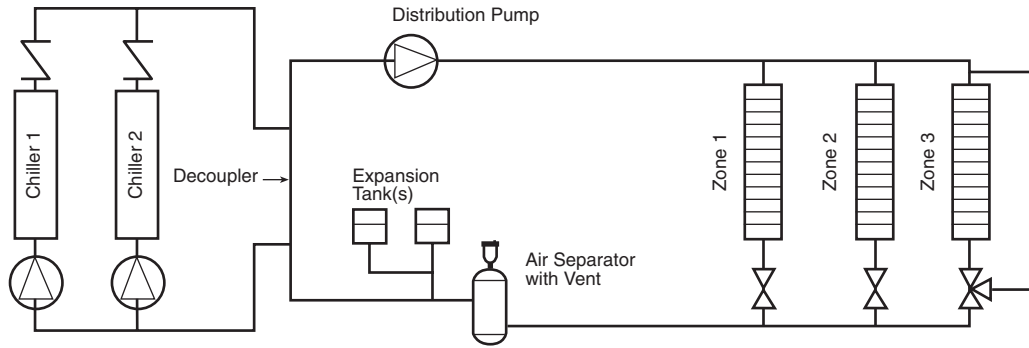

Fig. 22 — Tank Baffling



NOTE: Expansion tanks for 30RB hydronic kits must be installed for chillers piped in parallel in the primary water loop.

Fig. 23 — Typical Air Separator and Expansion Tank Location on Primary-Secondary Systems

Step 4 — Fill the Chilled Water Loop

IMPORTANT: Before starting unit, be sure all of the air has been purged from the system.

The chilled water pump (if equipped) is rated for 150 psig (1034 kPa) duty. The maximum cooler fluids side pressure is 300 psig (2068 kPa). Check the pressure rating for all of the chilled water devices installed. Do not exceed the lowest pressure rated device.

WATER SYSTEM CLEANING — Proper water system cleaning is of vital importance. Excessive particulates in the water system can cause excessive pump seal wear, reduce or stop flow, and cause damage of other components.

1. Install a temporary bypass around the chiller to avoid circulating dirty water and particulates into the pump package and chiller during the flush. Use a temporary circulating pump during the cleaning process. Also, be sure that there is capability to fully drain the system after cleaning. See Fig. 24.
2. Be sure to use a cleaning agent that is compatible with all system materials. Be especially careful if the system contains any galvanized or aluminum components. Both detergent-dispersant and alkaline-dispersant cleaning agents are available.
3. It is recommended to fill the system through a water meter. This provides a reference point for the future for loop volume readings, and it also establishes the correct quantity of cleaner needed in order to reach the required concentration.
4. Use a feeder/transfer pump to mix the solution and fill the system. Circulate the cleaning system for the length of time recommended by the cleaning agent manufacturer.
 - a. After cleaning, drain the cleaning fluid and flush the system with fresh water.
 - b. A slight amount of cleaning residue in the system can help keep the desired, slightly alkaline, water pH of 8 to 9. Avoid a pH greater than 10, since this will adversely affect pump seal components.
 - c. A side stream filter is recommended (see Fig. 25 during the cleaning process. Filter side flow rate should be enough to filter the entire water volume every 3 to 4 hours. Change filters as often as necessary during the cleaning process.
 - d. Remove temporary bypass when cleaning is complete.

A suction guide with an internal strainer is standard on all 30RB units with factory-installed hydronic packages. This strainer allows removal of particulates from the chilled water loop. Using the combination valve and the field-installed

isolation valve at the inlet, the strainer can be isolated from the chilled water loop to be cleaned.

The Carrier *ComfortLink*™ controls provided have a built-in feature to remind building owners or operators to clean the strainer at a pre-set time interval. Properly installed, cleaned and maintained systems will rarely need the strainer cleaned after the initial fill. This time interval is user-configurable.

Ideally, the chilled water loop will be cleaned before the unit is connected. If the run-in screen is left in the suction guide/strainer, it is recommended that the Service Maintenance be set to alert the operator within 24 hours of start-up to be sure that the run-in screen in the suction guide/strainer is not removed at start-up.

NOTE: The suction guide/strainer must be removed after the first 24 hours of operation.

To set the time for the parameter, go to Time Clock/MCFG/W.FIL in the Scrolling Marquee or the handheld Navigator™ display. Values for this item are input in days.

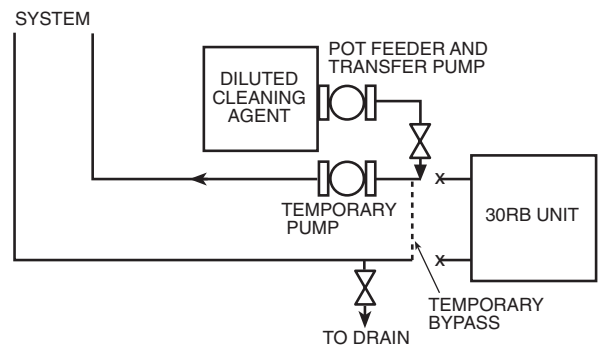

Fig. 24 — Typical Set Up for Cleaning Process

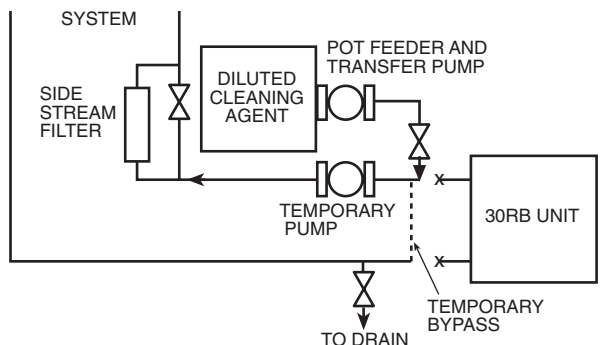

Fig. 25 — Cleaning Using a Side Stream Filter

WATER TREATMENT — Fill the fluid loop with water (or brine) and a corrosion-resistant inhibitor suitable for the water of the area. Consult the local water treatment specialist for characteristics of system water and a recommended inhibitor for the cooler fluid loop.

SYSTEM PRESSURIZATION — A proper initial cold fill pressure must be established before filling of the unit. The initial cold fill pressure is the pressure applied at the filling point to fill a system to its highest point, plus a minimum pressure at the top of the system (4 psig minimum [27.6 kPa]) to operate air vents and positively pressurize the system. The expansion tank is very important to system pressurization. The expansion tank serves several purposes:

1. Provide NPSHR (Net Positive Suction Head Required) for the pump to operate satisfactorily.
2. Set system pressure.
3. Accommodate expansion/contraction of water due to temperature changes.
4. Acts as a pressure reference for the pump.

The expansion tank pressure must be set BEFORE the system is filled. Follow the manufacturer's recommendation for instructions on setting the pressure in the expansion tank. NPSHR information is provided on the Pump Curves in Fig. 26-33 for units with factory-installed hydronic kits. See Table 6 for pump impeller sizes.

Once the system is pressurized, the pressure at the connection point of the expansion tank to water piping will not change unless the water loop volume changes (either due to addition/subtraction of water or temperature expansion/contraction). The pressure at this point remains the same regardless of whether or not the pump is running.

Since the expansion tank acts as a reference point for the pump, there cannot be two reference points (two expansion tanks) in a system, unless manifolded together. Where two or more 30RB chillers with the hydronic option are installed in parallel, there should not be more than one expansion tank in the system, unless manifolded together as seen in Fig. 23. It is permissible to install the expansion tank(s) in a portion of the return water line that is common to all pumps, providing that the tank is properly sized for combined system volume.

If the application involves two or more chillers in a primary secondary system, a common place for mounting the expansion tank is in the chilled water return line, just before the decoupler. See Fig. 23 for placement of expansion tank in primary-secondary systems.

If a diaphragm expansion tank is utilized (a flexible diaphragm physically separates the water/air interface) it is not recommended to have any air in the water loop. See the section on air separation on page 28 for instructions on providing air separation equipment.

FILLING THE SYSTEM — The initial fill of the chilled water system must accomplish three goals:

1. The entire piping system must be filled with water.
2. The pressure at the top of the system must be high enough to vent air from the system (usually 4 psig [27.6 kPa] is adequate for most vents).
3. The pressure at all points in the system must be high enough to prevent flashing in the piping or cavitation in the pump.

The pressure created by an operating pump affects system pressure at all points except one — the connection of the expansion tank to the system. This is the only location in the system where pump operation will not give erroneous pressure indications during the fill. Therefore, the best location to install the fill connection is close to the expansion tank. An air vent should be installed close by to help eliminate air that enters during the fill procedure.

When filling the system, ensure the following:

1. Remove temporary bypass piping and cleaning/flushing equipment.
2. Check to make sure all drain plugs are installed.

Normally, a closed system needs to be filled only once. The actual filling process is a fairly simple procedure. All air should be purged or vented from the system. Thorough venting at high points and circulation at room temperature for several hours is highly recommended.

NOTE: Local codes concerning backflow devices and other protection of the city water system should be consulted and followed to prevent contamination of the public water supply. This is critical when anti-freeze is used in the system.

Table 6 — Pump Impeller Sizes

UNIT 30RB	PUMP Hp	SINGLE PUMP				DUAL PUMP			
		Option Code*	Rpm	Impeller Dia. (in.)	Pump Curve	Option Code*	Rpm	Impeller Dia. (in.)	Pump Curve
060 070	3	0	1750	6.5	I	6	1750	6.5	V
	5	1	1750	7.3	I	7	1750	7.3	V
	7.5	2	1750	8.15	I	8	1750	8.15	V
						9	3450	5.25	VI
	10	3	3450	5.4	II	B	3450	5.9	VI
080 090 100	5	1	1750	7.3	I	7	1750	7.3	V
	7.5	2	1750	8.15	I	8	1750	8.15	V
	10	3	3450	5.4	II	B	3450	5.4	VII
	15	4	3450	6.1	II	C	3450	6.1	VII
110 120 130	5	1	1750	7.3	I	7	1750	7.3	V
	7.5	2	1750	8.15	I	8	1750	8.15	V
	10	3	3450	5.4	II	B	3450	5.4	VII
	15	4	3450	6.1	II	C	3450	6.1	VII
150 160 170 190	5	1	1750	6.5	III	—	—	—	—
	7.5	2	3450	4.6	IV	8	3450	4.6	VIII
	10	3	3450	5.0	IV	B	3450	5.0	VIII
	15	4	3450	5.5	IV	C	3450	5.5	VIII

*Option Code refers to the Hydronics Option (position 11) in the model number. See Fig. 1 for option identification.

NOTE: Pump Selections are chiller size dependent. For example, dual pump "C" on a 30RB170 chiller is not the same as dual pump "C" on a 30RB130 chiller.

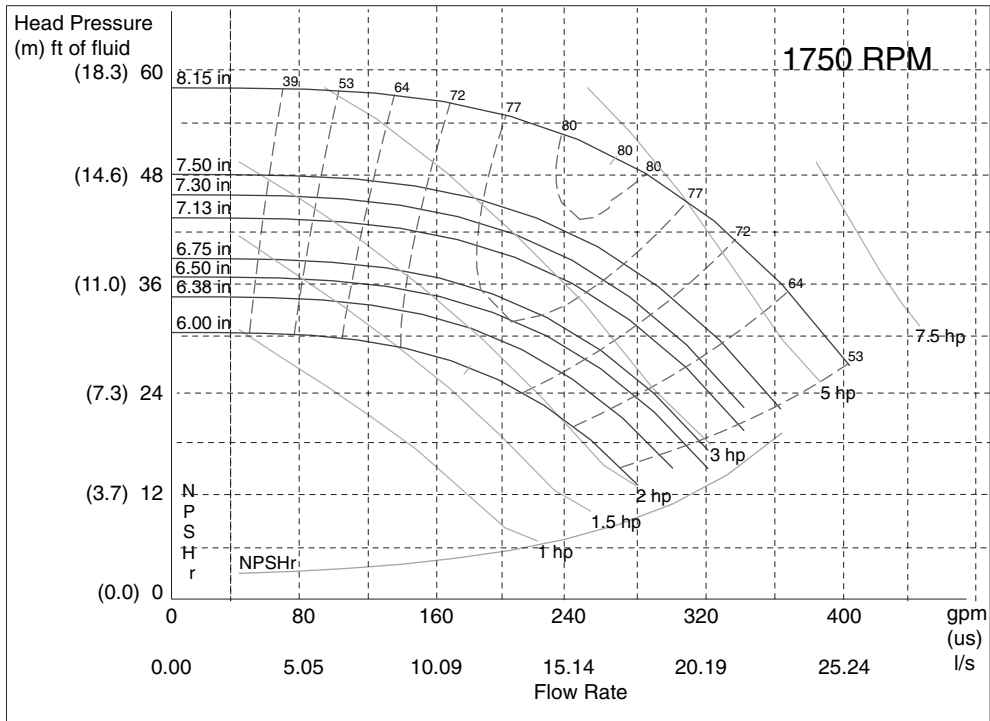

LEGEND

NPSHr — Net Positive Suction Head (Pressure) Required

NOTE: Refer to Fig. 1 option identification. Refer to the Pump Impeller Sizes table on page 32 for more information.

Fig. 26 — Pump Curve I for Hydronic Package Single Pump (Fresh Water)

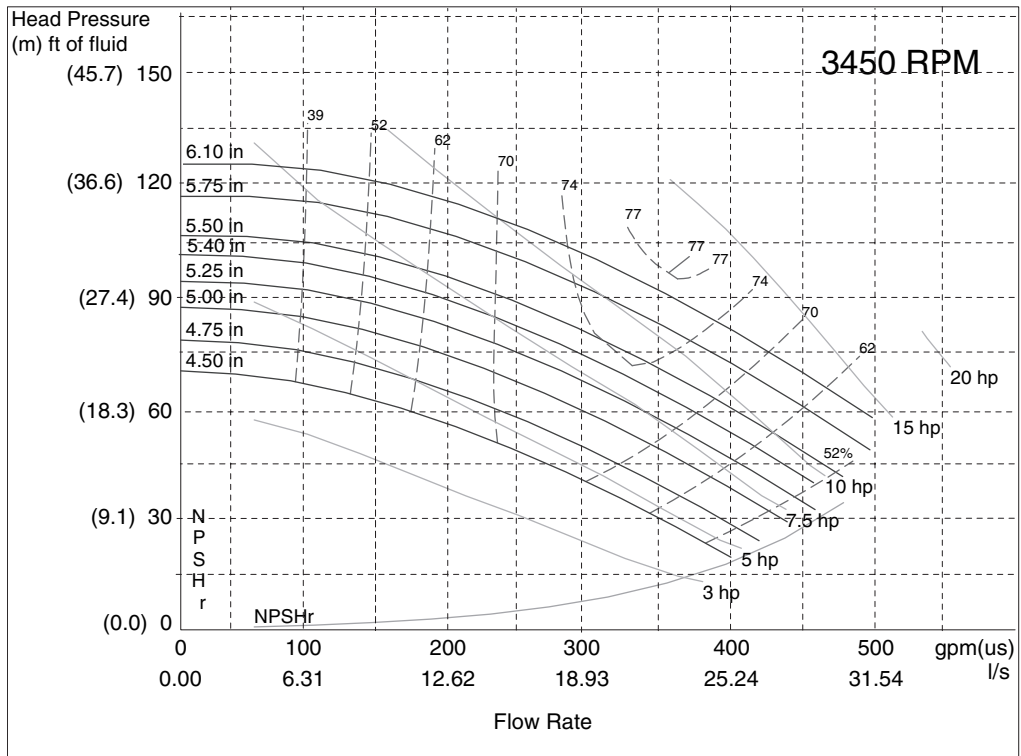

LEGEND

NPSHr — Positive Suction Head (Pressure) Required

NOTE: Refer to Fig. 1 option identification. Refer to the Pump Impeller Sizes table on page 32 for more information.

Fig. 27 — Pump Curve II for Hydronic Package Single Pump (Fresh Water)

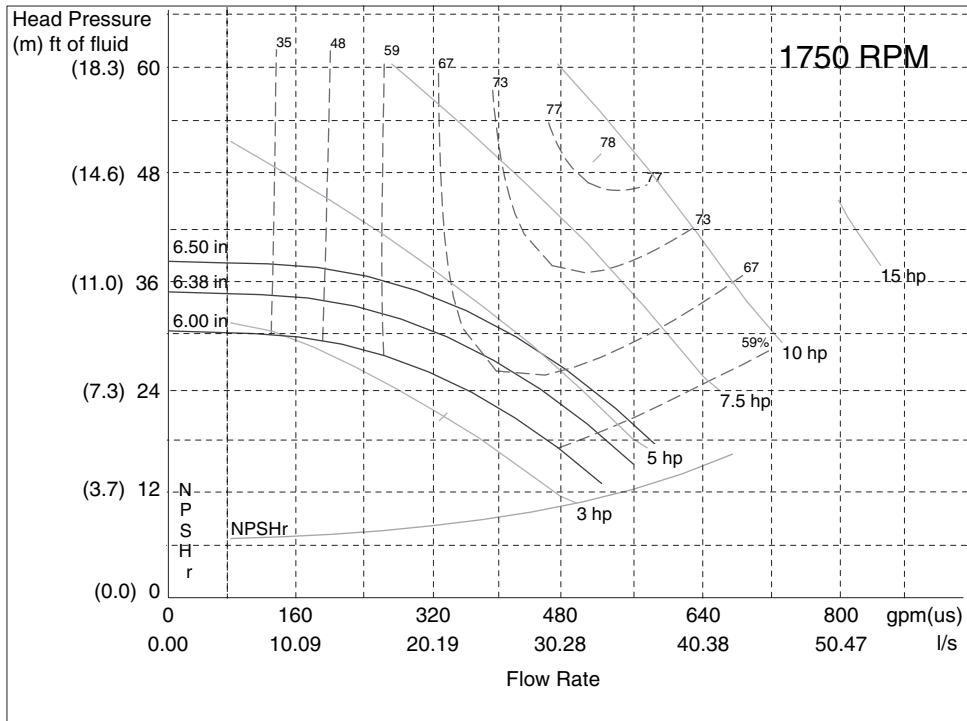

LEGEND

NPSHr — Positive Suction Head (Pressure) Required

NOTE: Refer to Fig. 1 option identification. Refer to the Pump Impeller Sizes table on page 32 for more information.

Fig. 28 — Pump Curve III for Hydronic Package Single Pump (Fresh Water)

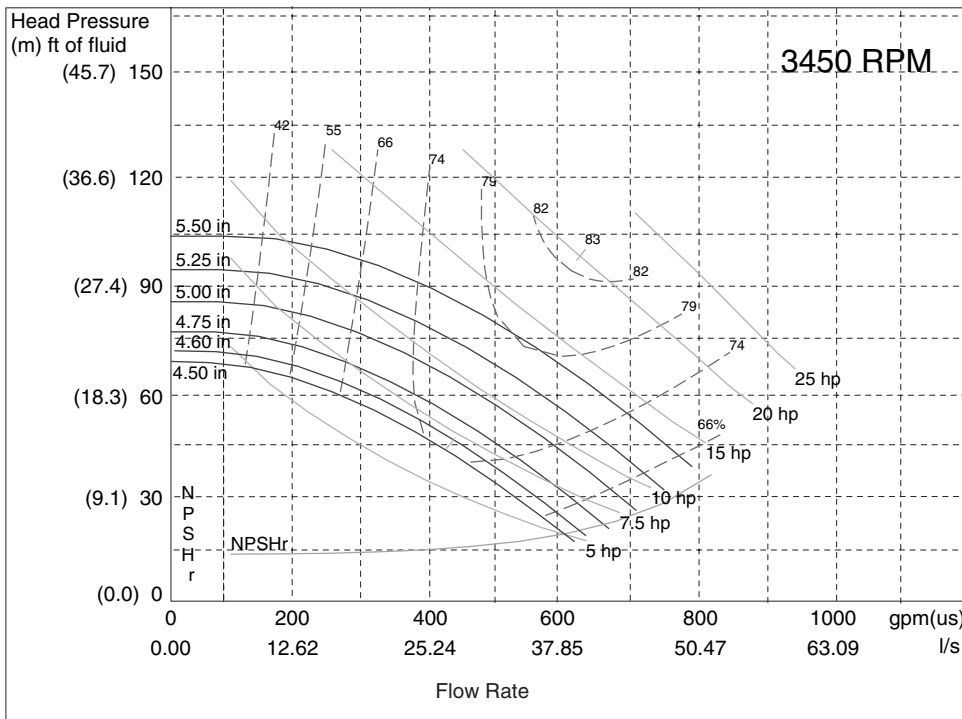

LEGEND

NPSHr — Positive Suction Head (Pressure) Required

NOTE: Refer to Fig. 1 option identification. Refer to the Pump Impeller Sizes table on page 32 for more information.

Fig. 29 — Pump Curve IV for Hydronic Package Single Pump (Fresh Water)

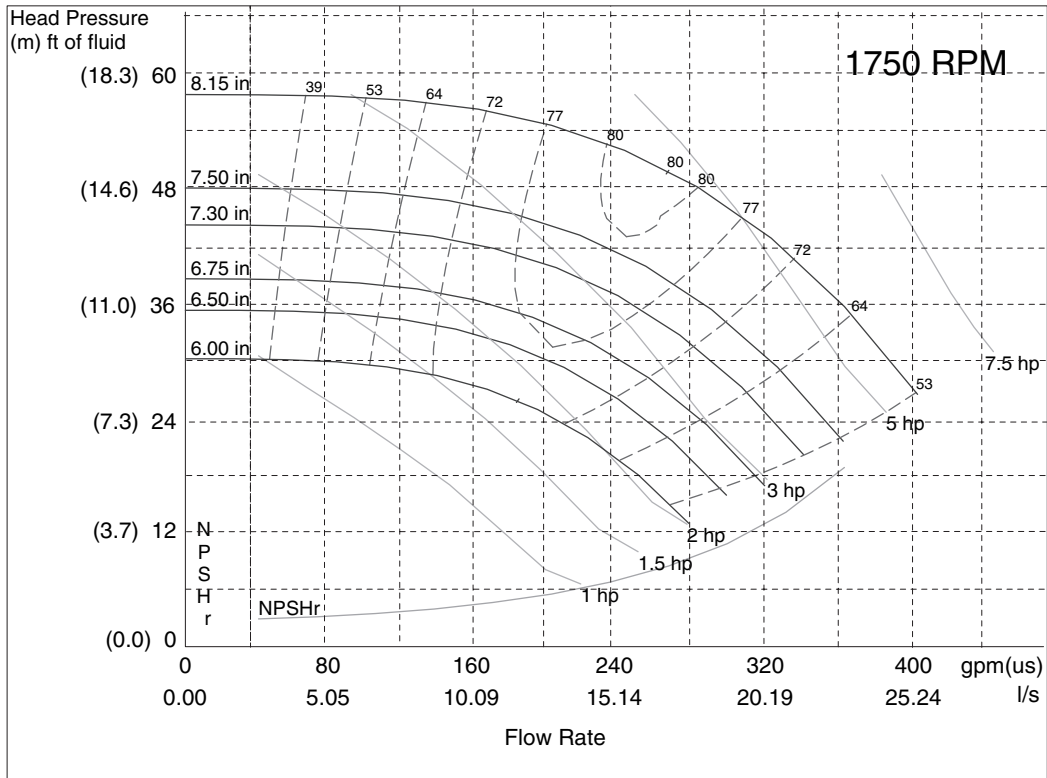

LEGEND

NPSHr — Positive Suction Head (Pressure) Required

NOTE: Refer to Fig. 1 option identification. Refer to the Pump Impeller Sizes table on page 32 for more information.

Fig. 30 — Pump Curve V for Hydronic Package Dual Pump (Fresh Water)

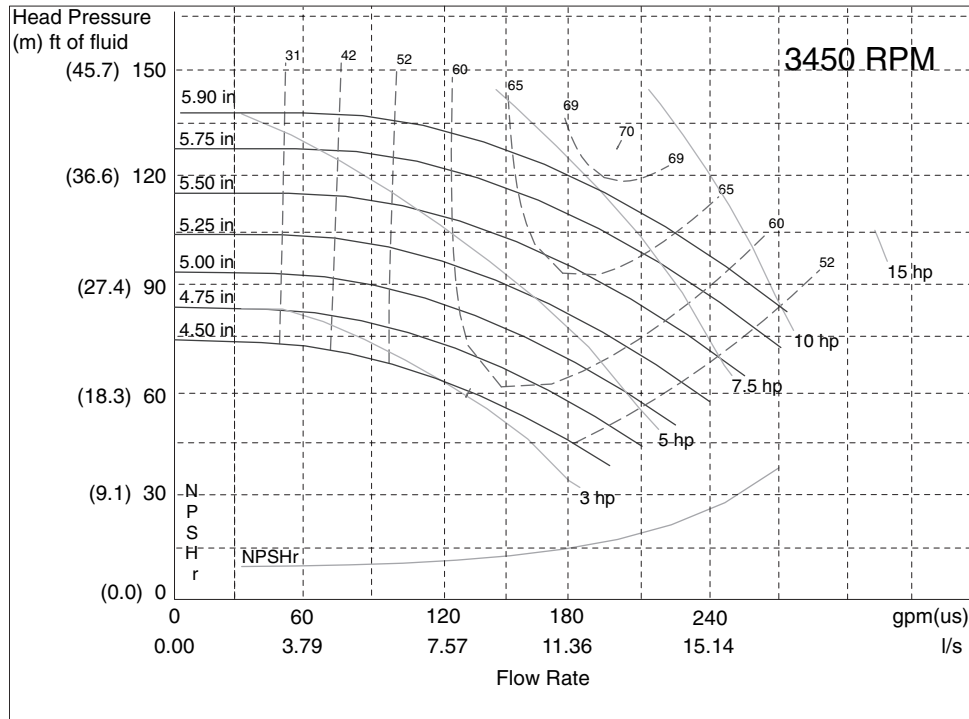

LEGEND

NPSHr — Positive Suction Head (Pressure) Required

NOTE: Refer to Fig. 1 option identification. Refer to the Pump Impeller Sizes table on page 32 for more information.

Fig. 31 — Pump Curve VI for Hydronic Package Dual Pump (Fresh Water)

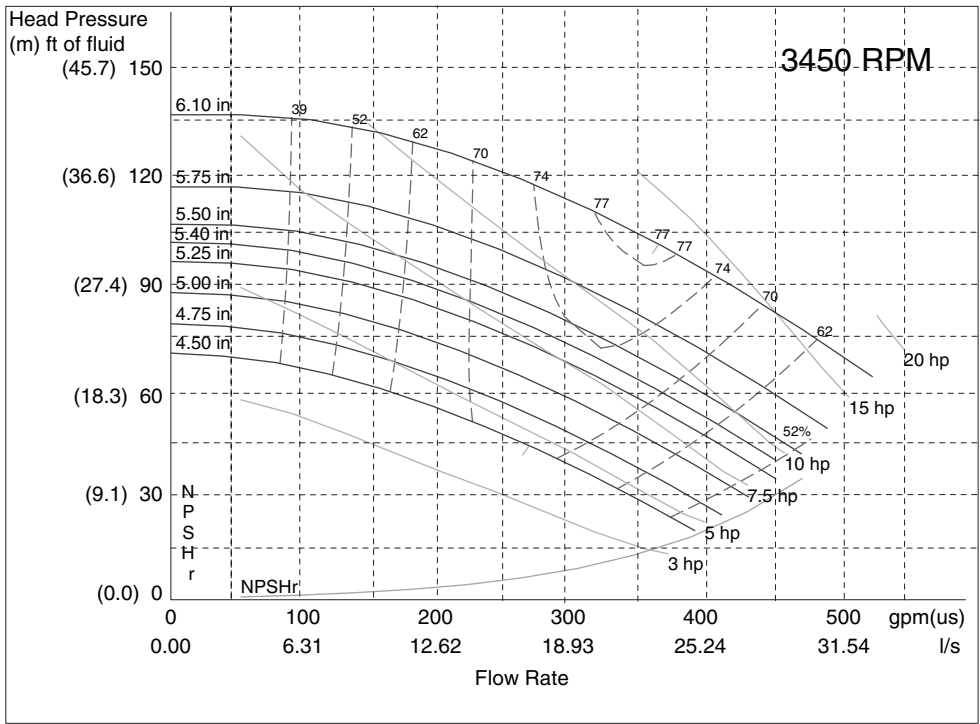

LEGEND

NPSH_r — Positive Suction Head (Pressure) Required

NOTE: Refer to Fig. 1 option identification. Refer to the Pump Impeller Sizes table on page 32 for more information.

Fig. 32 — Pump Curve VII for Hydronic Package Dual Pump (Fresh Water)

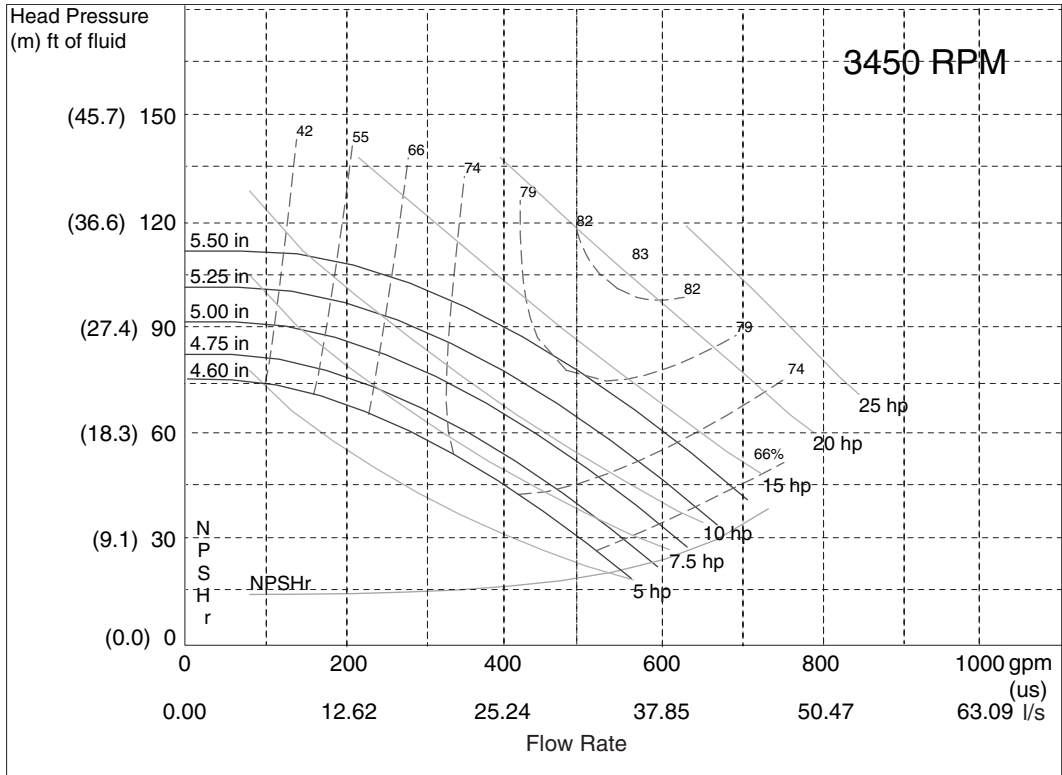

LEGEND

NPSH_r — Positive Suction Head (Pressure) Required

NOTE: Refer to Fig. 1 option identification. Refer to the Pump Impeller Sizes table on page 32 for more information.

Fig. 33 — Pump Curve VIII for Hydronic Package Dual Pump (Fresh Water)

SET WATER FLOW RATE — Once the system is cleaned, pressurized, and filled, the flow rate through the chiller needs to be established. On units with the hydronic package, this can be accomplished by using the balancing valve. Follow the manufacturer’s recommendations for setting the balancing valve. Local codes may prohibit restricting the amount of water using the balancing valve for a given motor horsepower. In this case, use the method listed in the Pump Modification/Trimming section. See Table 7 for the type of Combination Valve in 30RB units with the optional hydronic package.

Table 7 — Combination Valve Details

30RB UNIT	SINGLE/DUAL PUMP
060-130	FTV-4 in.
150-190	FTV-6 in.

NOTE: Carrier recommends a differential pressure gage when measuring pressures across the pumps or balancing valves. This provides for greater accuracy and reduces error build-up that often occurs when subtracting pressures made by different gages.

A rough estimate of water flow can also be obtained from the pressure gages across the 30RB heat exchanger.

Figure 34-36 shows the relationship between gpm and heat exchanger pressure drop. It should be noted that these curves are for fresh water and “clean” heat exchangers; they do not apply to heat exchangers with fouling. To read the chart, subtract the readings of the two pressure gages on the hydronic kit. This number is the pressure drop across the heat exchanger. Adjust the factory-installed balancing valve or external balancing valve (in units without hydronic package) until the correct pressure drop is obtained for the required gpm.

PUMP MODIFICATION/TRIMMING — Since the pumps are constant speed, the only way to obtain greater flow with a given pump/impeller is to decrease system head. This will allow the pump to “ride” its curve to the right, resulting in increased flow. If greater flow is necessary, consider opening the combination valve. Also, verify that the strainer is clean, and that no unnecessary system resistance is present, such as partially closed isolation valves.

Once the combination valve is set, note the stem position. If later service work requires the valve to be closed, it will be easier to re-balance the system, if the original balance point is known.

Increasing system resistance by closing the balancing valve will force the pump to “ride” its curve to the left, resulting in less flow. Although this does reduce power consumption slightly, it may not be the desirable method of reducing the flow, especially if a large reduction is needed.

The other method for reducing flow on a constant speed pump is impeller trimming. The impellers in the pumps provided in the 30RB hydronic kit can be easily removed for this purpose. Refer to the vendor literature packet supplied with the hydronic package information on Seal Replacement in the Service Section, and follow instructions for impeller removal and trimming. See Fig. 37-44 for pump envelope curve information. Trimming should only be done by a qualified machine shop that has experience in this operation. Contact your local Carrier representative for a recommended machine shop.

⚠ CAUTION

After trimming, the impeller **MUST** be balanced. Failure to balance trimmed impellers can result in excessive vibration, noise, and premature bearing failure.

Impeller trimming has the added benefit of maximum bhp (brake horsepower) savings, which can recover the cost incurred by performing the impeller trimming.

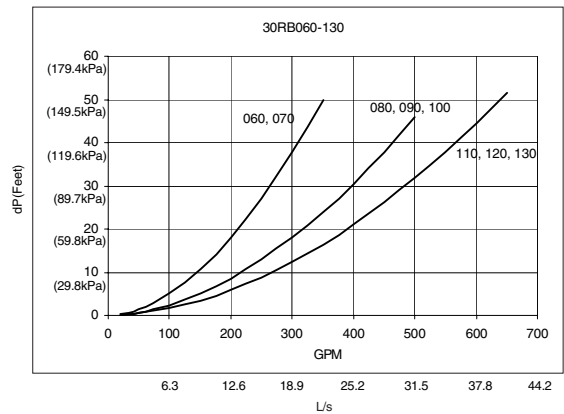

Fig. 34 — 30RB060-130 Cooler Pressure Drop Curves

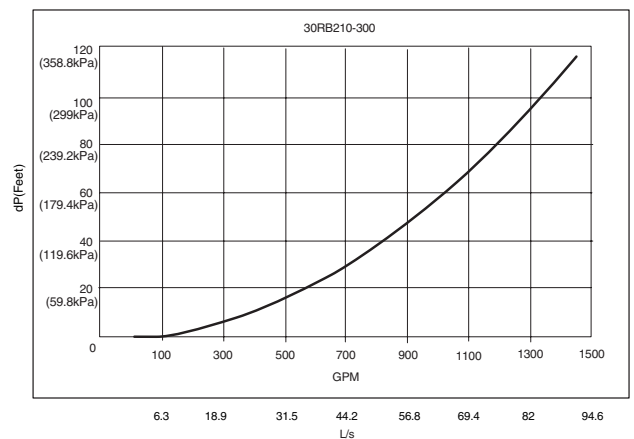

Fig. 35 — 30RB210-300 Cooler Pressure Drop Curve

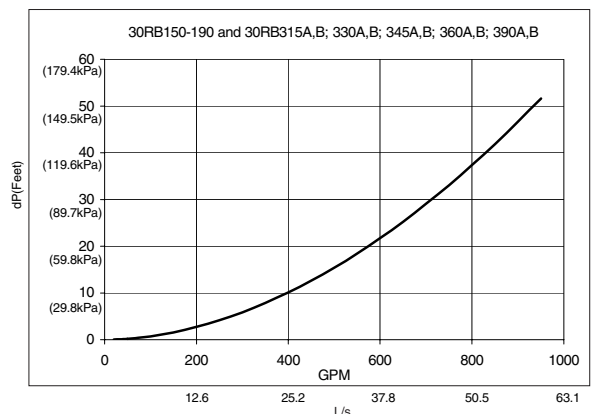
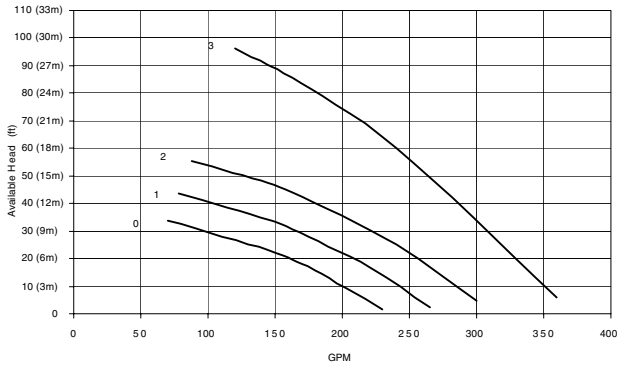
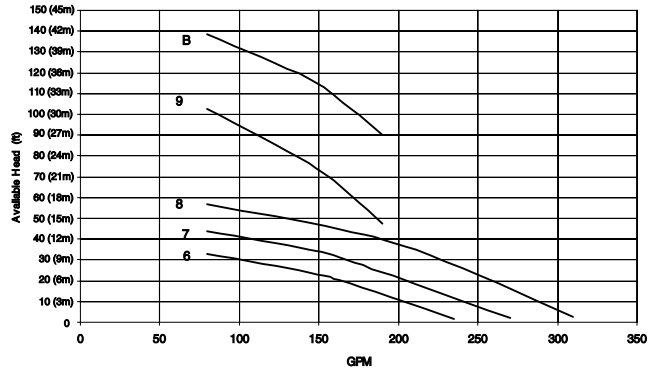

Fig. 36 — 30RB150-190 and 30RB315A,B; 330A,B; 345A,B; 360A,B; 390A,B Cooler Pressure Drop Curve



NOTE: Refer to Fig. 1 for pump envelope curve option identification.

Fig. 37 — 30RB060, 070 — Single Pump Envelope Curves



NOTE: Refer to Fig. 1 for pump envelope curve option identification.

Fig. 41 — 30RB060, 070 — Dual Pump Envelope Curves

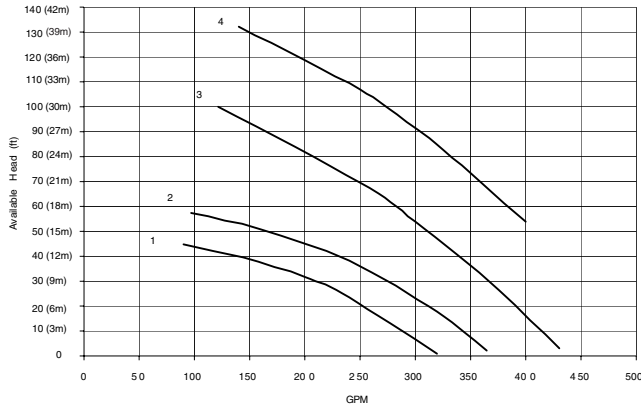

NOTE: Refer to Fig. 1 for pump envelope curve option identification.

Fig. 38 — 30RB080, 090, 100 — Single Pump Envelope Curves

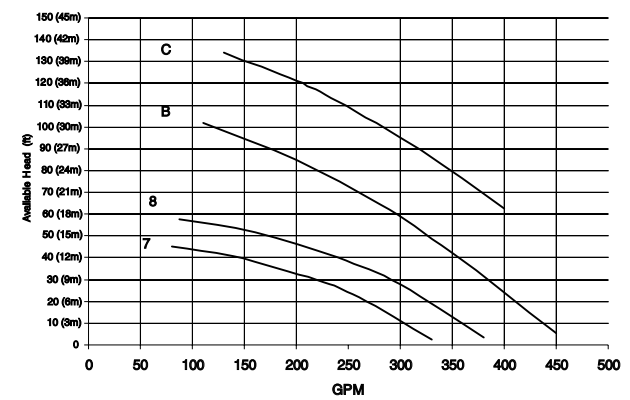

NOTE: Refer to Fig. 1 for pump envelope curve option identification.

Fig. 42 — 30RB080, 090, 100 — Dual Pump Envelope Curves

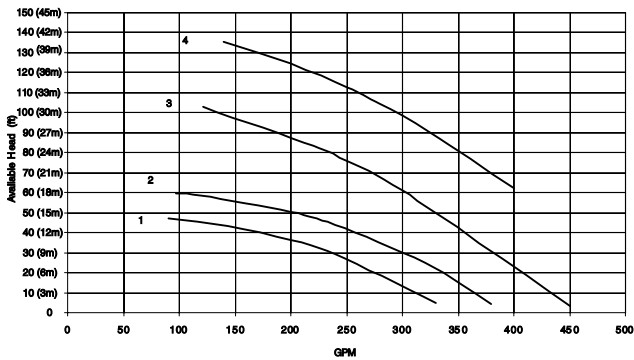

NOTE: Refer to Fig. 1 for pump envelope curve option identification.

Fig. 39 — 30RB110, 120, 130 — Single Pump Envelope Curves

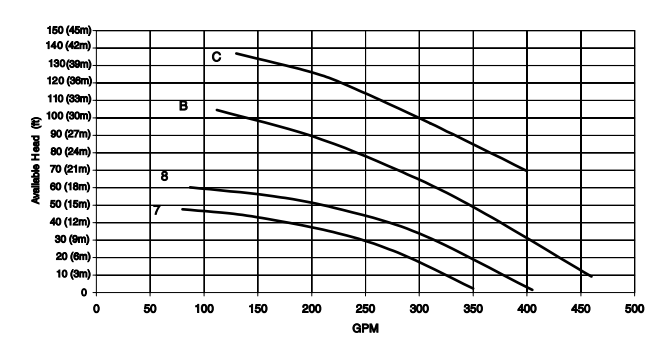

NOTE: Refer to Fig. 1 for pump envelope curve option identification.

Fig. 43 — 30RB110, 120, 130 — Dual Pump Envelope Curves

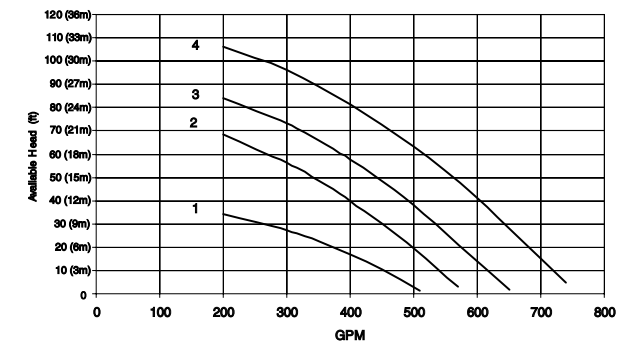

NOTE: Refer to Fig. 1 for pump envelope curve option identification.

Fig. 40 — 30RB160, 170, 190 — Single Pump Envelope Curves

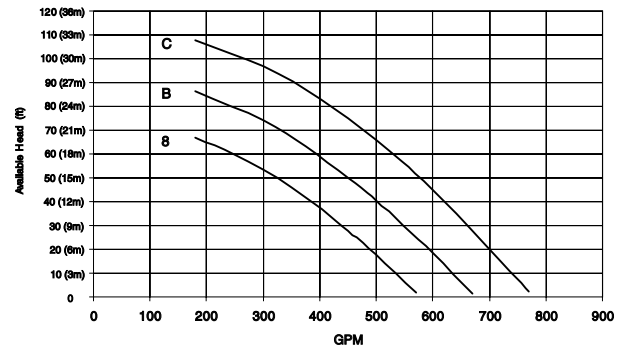

NOTE: Refer to Fig. 1 for pump envelope curve option identification.

Fig. 44 — 30RB160, 170, 190 — Single Pump Envelope Curves

PREPARATION FOR YEAR ROUND OPERATION — If the unit is in operation year-round, add sufficient suitable inhibited antifreeze solution such as propylene or ethylene glycol to chilled water to prevent freezing under low-ambient operating conditions. Consult local water treatment specialist on characteristics of water and recommended inhibitor.

IMPORTANT: Glycol anti-freeze solutions are highly recommended since heater tapes provide no protection in the event of a power failure.

If the unit is equipped with Motormaster® control, field-fabricated and field-installed wind baffles are required if the wind velocity is anticipated to be greater than 5 mph (8 km/h). Two different baffles are required, one for the control box end and one for the opposite control box end. Wind baffles should be constructed with minimum 18-gage galvanized sheet metal or other suitable corrosion-resistance material with cross breaks for strength. Use field-supplied screws to attach baffles to the corner posts of the machine. Be sure to hem or turn a flange on all edges to eliminate sharp edges on the baffles.

▲ WARNING

To avoid possibility of electrical shock, open all disconnects before installing or servicing this accessory.

▲ CAUTION

To avoid damage to the refrigerant coils and electrical components, use extreme care when drilling screw holes and screwing in fasteners.

Mount the smaller height baffle on the control box end. It is recommended that the upper notches be used for mounting the baffles. This reduces the risk of damaging the coil while drilling a mounting hole. Loosen the upper corner post bolts and slide the baffle under the bolt and washer. Tighten the bolt. Drill holes in the bottom of the flange of the baffle and mount with two screws to secure the bottom of the baffle to the corner post. Repeat the process for the opposite side. See Fig. 45.

FREEZE PROTECTION — The 30RB units are provided with a flow switch to protect against freezing situations that occur from no water flow. While the flow switch is helpful in preventing freezing during no-flow situations, it does not protect the chiller in case of power failure during sub-freezing ambient temperatures, or in other cases where water temperature falls below the freezing mark. Appropriate concentrations of inhibited propylene or ethylene glycol or other suitable inhibited antifreeze solution should be considered for chiller protection where ambient temperatures are expected to fall below 32 F (0° C). Consult local water treatment specialist on characteristics of the system water and add a recommended inhibitor to the chilled water. The Carrier warranty does not cover damage due to freezing.

1. If the pump will be subjected to freezing temperatures, steps must be taken to prevent freeze damage. If the pump will not be used during this time, it is recommended to drain the pump and hydronic package and these components are back-flushed with inhibited glycol. Otherwise, a glycol-water solution should be considered as the heat

transfer fluid. Drains are located on the pump(s) and suction guide/strainer for units with hydronic kits. Units without hydronic kits have a drain mounted on the bottom of the heat exchanger near the leaving water connection of the heat exchanger.

NOTE: Do not use automobile anti-freeze, or any other fluid that is not approved for heat exchanger duty. Only use appropriately inhibited glycols, concentrated to provide adequate protection for the temperature considered.

2. Use an electric tape heater for the external piping, if unit will be exposed to freezing temperatures.
3. Ensure that power is available to the chiller at all times, even during the off-season, so that the pump and cooler heaters have power. Also make sure that the piping tape heaters have power.
4. On units with pump packages, a heater is supplied with the hydronic package that will protect this section from freezing in outdoor-air temperatures down to -20 F (-29 C), except in the case of a power failure. The Carrier warranty does not cover damage due to freezing.
5. Cooler heaters that will protect components down to -20 F (-28.9 C) can be ordered as a factory-installed option. Again, it should be noted that these heaters will not protect the cooler from freezing in the event of a power failure. The Carrier warranty does not cover damage due to freezing.

PREPARATION FOR WINTER SHUTDOWN — If the unit is not operational during the winter months, at the end of cooling season:

▲ CAUTION

Failure to remove power before draining heater equipped coolers and hydronic packages can result in heater tape and insulation damage.

1. If the unit has optional heater tapes on the cooler and the cooler will not be drained, do not shut off power disconnect during off-season shutdown. If the unit has optional heater tapes on the cooler and the cooler will be drained, open the circuit breaker for the heater tapes, CB-HT or shut off power during off-season shutdown.
2. Draining the fluid from the system is highly recommended. If the unit is equipped with a hydronic package, there are additional drains in the pump housing and strainer that must be opened to allow for all of the water to drain.
3. Replace the drain plug and add 2 gallons (7.6 liters) of a suitable corrosion-inhibited anti-freeze solution such as propylene glycol to the cooler to prevent freezing of any remaining water in system. Antifreeze can be added through the vent on top of cooler. If the unit has a hydronic pump package, the pump must also be treated in the same manner.
4. Open one of the thermistor connections to allow air to escape the vessel and the anti-freeze to enter.
5. At the beginning of the next cooling season, be sure that there is refrigerant pressure on each circuit before refilling cooler, add recommended inhibitor, and reset the CB-HT (circuit breaker heater) (if opened) or restore power.

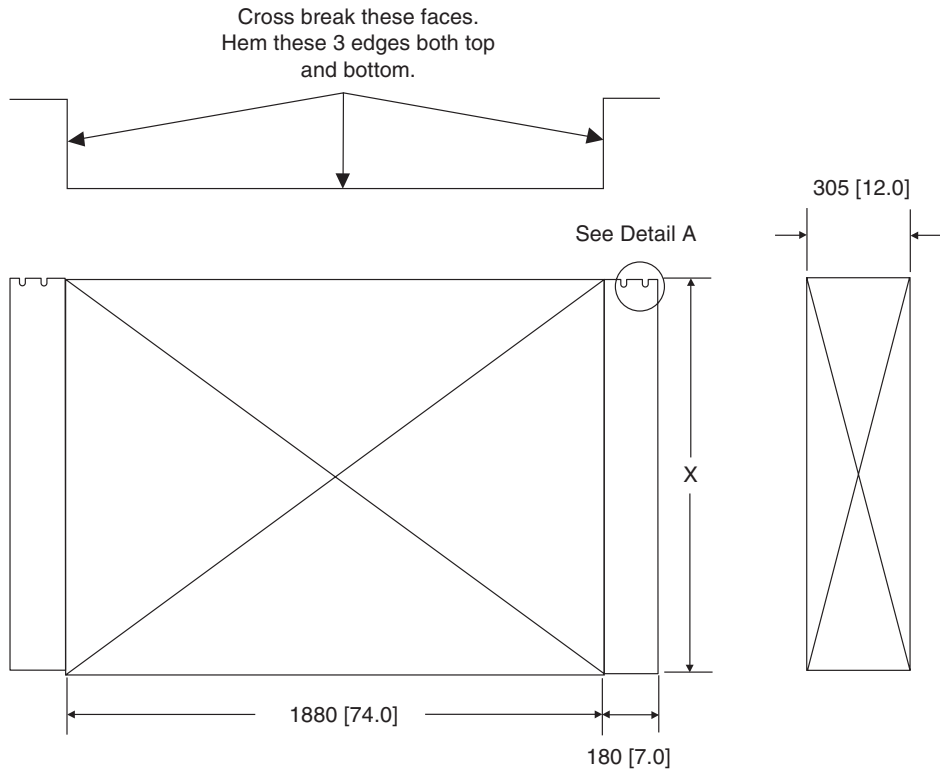

POSITION	BAFFLE HEIGHT (X)
Control/Power End	635 [25.0]
Opposite Control Power End	1040 [41.0]

Material: 18 ga. Corrosion Resistant Sheet Metal.
Dimensions are in mm [inches].

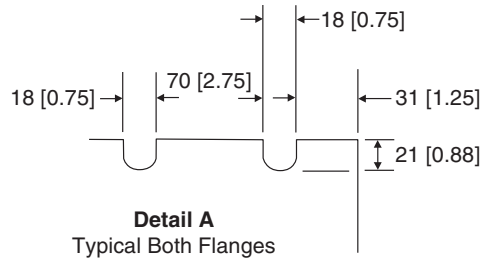

Fig. 45 — Field-Fabricated and Field-Installed Wind Baffles

Step 5 — Make Electrical Connections



ELECTRIC SHOCK HAZARD

Open all remote disconnects before servicing this equipment.

POWER SUPPLY — The electrical characteristics of the available power supply must agree with the unit nameplate rating. Supply voltage must be within the limits shown. Some units have options for multiple power connections. See Tables 8-12 for electrical requirements and Fig. 46 for electrical connection information.

IMPORTANT: Operating unit on improper supply voltage or with excessive phase imbalance constitutes abuse and may adversely affect Carrier warranty.

POWER WIRING — All power wiring must comply with applicable local and national codes. Install field-supplied branch circuit fused disconnect per NEC of a type that can be locked OFF or OPEN. Disconnect must be within sight and readily accessible from the unit in compliance with NEC Article 440-14. In the power box, $\frac{7}{8}$ in. holes are provided for power entry. The holes will need to be enlarged to accept the appropriate conduit. NEC also requires all conduits from a conditioned space to the power box(es) be sealed to prevent airflow and moisture into the control box.

Duplex units require at least two separate power supplies, at least one for each module, depending on the power supply option ordered. See Fig. 46.

General Wiring Notes:

1. The control circuit does NOT require a separate power source. A step-down transformer from the main three-phase power supply obtains control circuit power. Be sure that the appropriate connection tap is connected on all transformers for the supply voltage. Up to two terminal blocks are provided for field-wired control devices.
2. Cooler and pump heaters (if factory installed) are wired in the control circuit so they are operable as long as the main power supply to the unit is ON. A factory-installed and set overload device protects them.

NOTE: The field-supplied disconnect should never be off except when unit is being serviced or is to be down for a prolonged period, in which case the cooler should be drained.

3. Power entry depends on the size and power entry option ordered.
4. Maximum field wire sizes allowed by lugs on terminal block/non-fused disconnect are listed in Tables 8 and 9.
5. Terminals for field power supply are suitable for copper conductors. Insulation must be rated 75 C minimum.

IMPORTANT: To ensure power to the heaters, make sure power to the unit is always on (except during service or a prolonged shutdown).

⚠ CAUTION

Proper rotation of condenser fan(s) and pump(s) MUST be verified before pumps or compressors are started. Consult the Controls, Start-Up and Operation guide provided with 30RB060-390 units for correct procedure. Improper pump rotation can cause permanent damage to pump impeller and housing. If pump(s) have been removed for trimming, verify wiring is reconnected in the original manner.

CONTROL POWER — Control power is obtained from the main power supply and does NOT require a separate source. A toggle switch (marked SW2 on the unit label diagram and by the switch) allows the control circuit to be manually disconnected when necessary. Cooler and pump heaters (if installed) are in an inoperable state when this switch is in the Off position.

IMPORTANT: For 208-v systems, the connection tap for all transformers must be changed. The factory default setting is for 230-v. Failure to connect to the proper tap may result in unreliable operation.

FIELD CONTROL OPTION WIRING — Install field control wiring options. See Fig. 46. Some options, such as 4 to 20 mA Demand Limit that requires the Energy Management Module, may require that accessories be installed first if not factory installed for terminal connections.

DUAL CHILLER LEAVING WATER SENSOR — If the Dual Chiller algorithm is used and the machines are installed in parallel, an additional chilled water sensor must be installed for each chiller. For 30RB315-390 units, a factory-supplied thermistor and well are shipped in the control box of each. Install the well in the common leaving water header. See Fig 21. DO NOT relocate the chiller's leaving water thermistors. They must remain in place for the unit to operate properly.

The thermistor well is a $\frac{1}{4}$ in. NPT fitting for securing the well in the piping. The piping must be drilled and tapped for the well. Select a location that will allow for removal of the thermistor without any restrictions. See Fig. 47.

Once the well is inserted, install the thermistors. Insert the thermistor into the well until the o-ring reaches the well body. Use the nut on the thermistor to secure the thermistor in place. Once the thermistor is in place, it is recommended that a thermistor wire loop be made and secured with a wire tie to the chilled water pipe. This will aid in thermistor retention in the well. See Fig. 48.

For 30RB315-390 units, as well as all units using the dual chiller algorithm, a Carrier Comfort Network (CCN) bus must be connected between the two modules. See the Carrier Comfort Network Communication Bus Wiring for additional information.

Table 8 — 30RB Electrical Data — Single Point Units

UNIT 30RB	UNIT VOLTAGE		NO HYDRONIC PACKAGE				3 HP PUMP, 1750 RPM				5 HP PUMP, 1750 RPM				
	V-Hz (3 Ph)	Supplied		MCA	MOCP	ICF	Rec Fuse	MCA	MOCP	ICF	Rec Fuse	MCA	MOCP	ICF	Rec Fuse
		Min	Max	XL	XL	XL	Size	XL	XL	XL	Size	XL	XL	XL	Size
060	208/230-60	187	253	291.5	350	682.8	350	302.4	350	693.6	350	309.2	350	700.5	350
	460-60	414	506	127.9	150	302.0	150	132.8	150	306.9	150	135.9	150	310.0	150
	575-60	518	633	102.4	125	244.7	110	106.4	125	248.6	125	108.8	125	251.1	125
	380-60	342	418	150.9	175	362.9	175	156.9	175	368.8	175	160.6	175	372.6	175
070	208/230-60	187	253	334.7	400	777.0	400	345.6	400	787.8	400	352.4	400	794.7	400
	460-60	414	506	147.9	175	355.9	175	152.8	175	360.8	175	155.9	175	363.9	175
	575-60	518	633	119.8	150	287.4	150	123.7	150	291.3	150	126.2	150	293.8	150
	380-60	342	418	175.5	200	428.8	200	181.4	225	434.7	200	185.2	225	438.5	200
080	208/230-60	187	253	366.5	400	757.8	400	—	—	—	—	384.2	450	775.5	450
	460-60	414	506	160.6	175	334.7	175	—	—	—	—	168.6	200	342.7	200
	575-60	518	633	128.6	150	270.9	150	—	—	—	—	135.0	150	277.3	150
	380-60	342	418	189.3	225	401.3	200	—	—	—	—	199.0	225	411.0	225
090	208/230-60	187	253	433.6	500	875.9	500	—	—	—	—	451.3	500	893.6	500
	460-60	414	506	191.4	225	399.4	225	—	—	—	—	199.4	225	407.4	225
	575-60	518	633	154.6	175	322.2	175	—	—	—	—	161.0	175	328.6	175
	380-60	342	418	226.9	250	480.3	250	—	—	—	—	236.6	250	490.0	250
100	208/230-60	187	253	472.0	500	914.3	500	—	—	—	—	489.7	500	932.0	500
	460-60	414	506	209.2	250	417.2	225	—	—	—	—	217.2	250	425.2	250
	575-60	518	633	170.0	200	337.6	200	—	—	—	—	176.4	200	344.0	200
	380-60	342	418	248.7	250	502.1	250	—	—	—	—	258.4	300	511.8	300
110	208/230-60	187	253	508.6	600	950.9	600	—	—	—	—	526.3	600	968.6	600
	460-60	414	506	224.1	250	432.1	250	—	—	—	—	232.1	250	440.1	250
	575-60	518	633	180.8	200	348.4	200	—	—	—	—	187.2	200	354.8	200
	380-60	342	418	265.3	300	518.7	300	—	—	—	—	275.0	300	528.4	300
120	208/230-60	187	253	590.1	600	1032.3	600	—	—	—	—	607.8	700	1050.0	700
	460-60	414	506	261.6	300	469.6	300	—	—	—	—	269.6	300	477.6	300
	575-60	518	633	212.5	225	380.2	225	—	—	—	—	218.9	250	386.6	250
	380-60	342	418	311.1	350	564.5	350	—	—	—	—	320.8	350	574.2	350
130	208/230-60	187	253	626.7	700	1068.9	700	—	—	—	—	644.4	700	1086.6	700
	460-60	414	506	276.5	300	484.5	300	—	—	—	—	284.5	300	492.5	300
	575-60	518	633	223.3	250	391.0	250	—	—	—	—	229.7	250	397.4	250
	380-60	342	418	327.7	350	581.1	350	—	—	—	—	337.4	350	590.8	350
150	208/230-60	187	253	684.3	700	1126.5	700	—	—	—	—	702.0	800	1144.2	800
	460-60	414	506	303.2	350	511.2	350	—	—	—	—	311.2	350	519.2	350
	575-60	518	633	246.4	250	414.1	250	—	—	—	—	252.8	300	420.5	300
	380-60	342	418	360.4	400	613.8	400	—	—	—	—	370.1	400	623.5	400
160	208/230-60	187	253	744.8	800	1187.0	800	—	—	—	—	762.5	800	1204.7	800
	460-60	414	506	328.9	350	536.9	350	—	—	—	—	336.9	350	544.9	350
	575-60	518	633	265.9	300	433.5	300	—	—	—	—	272.3	300	439.9	300
	380-60	342	418	390.1	400	643.5	400	—	—	—	—	399.8	400	653.2	400
170	208/230-60	187	253	802.4	1000	1244.6	1000	—	—	—	—	820.1	1000	1262.3	1000
	460-60	414	506	355.6	400	563.6	400	—	—	—	—	363.6	400	571.6	400
	575-60	518	633	289.0	300	456.6	300	—	—	—	—	295.4	300	463.0	300
	380-60	342	418	422.8	450	676.2	450	—	—	—	—	432.5	450	685.9	450
190	208/230-60	187	253	920.5	1000	1362.7	1000	—	—	—	—	938.2	1000	1380.4	1000
	460-60	414	506	408.0	450	616.0	450	—	—	—	—	416.0	450	624.0	450
	575-60	518	633	331.5	350	499.1	350	—	—	—	—	337.9	350	505.5	350
	380-60	342	418	485.2	500	738.5	500	—	—	—	—	494.9	500	748.2	500
210	208/230-60	187	253	—	—	—	—	—	—	—	—	—	—	—	—
	460-60	414	506	422.9	450	630.9	450	—	—	—	—	—	—	—	—
	575-60	518	633	342.3	350	509.9	350	—	—	—	—	—	—	—	—
	380-60	342	418	501.8	600	755.1	600	—	—	—	—	—	—	—	—
225	208/230-60	187	253	—	—	—	—	—	—	—	—	—	—	—	—
	460-60	414	506	449.6	450	657.6	450	—	—	—	—	—	—	—	—
	575-60	518	633	365.4	400	533.0	400	—	—	—	—	—	—	—	—
	380-60	342	418	534.5	600	787.8	600	—	—	—	—	—	—	—	—
250	208/230-60	187	253	—	—	—	—	—	—	—	—	—	—	—	—
	460-60	414	506	502.0	600	710.0	600	—	—	—	—	—	—	—	—
	575-60	518	633	408.0	450	575.6	450	—	—	—	—	—	—	—	—
	380-60	342	418	596.8	600	850.2	600	—	—	—	—	—	—	—	—
275	208/230-60	187	253	—	—	—	—	—	—	—	—	—	—	—	—
	460-60	414	506	554.4	600	762.4	600	—	—	—	—	—	—	—	—
	575-60	518	633	450.5	500	618.1	500	—	—	—	—	—	—	—	—
	380-60	342	418	659.2	700	912.6	700	—	—	—	—	—	—	—	—
300	208/230-60	187	253	—	—	—	—	—	—	—	—	—	—	—	—
	460-60	414	506	606.8	700	814.8	700	—	—	—	—	—	—	—	—
	575-60	518	633	493.0	500	660.7	500	—	—	—	—	—	—	—	—
	380-60	342	418	721.6	800	975.0	800	—	—	—	—	—	—	—	—

LEGEND

ICF — Instantaneous Current Flow **MOCP** — Maximum Overcurrent Protection
MCA — Minimum Circuit Amps **XL** — Across-the-Line Start

NOTES:

- Units are suitable for use on electrical systems where voltage supplied to the unit terminals is not below or above the listed minimum and maximum limits. Maximum allowable phase imbalance is: voltage, 2%; amps 10%.
- All units/modules have single point primary power connection. (Each unit/module requires its own power supply.) Main power must be supplied from a field-supplied disconnect.
- Cooler heater is wired into the control circuit so it is always operable as long as the power supply disconnect is on, even if any safety device is open.
- For MCA that is less than or equal to 380 amps, 3 conductors are required.
 For MCA between 381-760 amps, 6 conductors are required.
 For MCA between 761-1140 amps, 9 conductors are required.
 For MCA between 1141-1520 amps, 12 conductors are required.
 Calculation of conductors required is based on 75 C copper wire.

- Wiring for main field supply must be rated 75 C minimum. Use copper for all units.
 - Incoming wire size range for the terminal block is #4 AWG to 500 kcmil.
 - Incoming wire size range of non-fused disconnect with MCA up to 599.9 amps is 3/0 to 500 kcmil.
 - Incoming wire size range of non-fused disconnect with MCA from 600 to 799.9 amps is 1/0 to 500 kcmil.
 - Incoming wire size range of non-fused disconnect with MCA from 800 to 1199.9 amps is 250 kcmil to 500 kcmil.
- Hydronic pump packages are not available as a factory-installed option for units 30RB210-390.
- Power draw includes both crankcase heaters and cooler heaters (where used). Each compressor has a crankcase heater which draws 56 watts of power. Units ordered with the cooler heater option have 1 (060-150) or 2 (160-300) cooler heaters, 825 watts each.



208/230
460
575 v only

Table 8 — 30RB Electrical Data — Single Point Units (cont)

UNIT 30RB	UNIT VOLTAGE				NO HYDRONIC PACKAGE				3 HP PUMP, 1750 RPM				5 HP PUMP, 1750 RPM			
	V-Hz (3 Ph)	Supplied		MCA	MOCP	ICF	Rec Fuse Size	MCA	MOCP	ICF	Rec Fuse Size	MCA	MOCP	ICF	Rec Fuse Size	
		Min	Max	XL	XL	XL		XL	XL	XL		XL				
315	A	208/230-60	187	253	744.8	800	1187.0	800	—	—	—	—	—	—	—	—
		460-60	414	506	328.9	350	536.9	350	—	—	—	—	—	—	—	—
		575-60	518	633	265.9	300	433.5	300	—	—	—	—	—	—	—	—
		380-60	342	418	390.1	400	643.5	400	—	—	—	—	—	—	—	—
	B	208/230-60	187	253	744.8	800	1187.0	800	—	—	—	—	—	—	—	—
		460-60	414	506	328.9	350	536.9	350	—	—	—	—	—	—	—	—
		575-60	518	633	265.9	300	433.5	300	—	—	—	—	—	—	—	—
		380-60	342	418	390.1	400	643.5	400	—	—	—	—	—	—	—	—
330	A	208/230-60	187	253	802.4	1000	1244.6	1000	—	—	—	—	—	—	—	—
		460-60	414	506	355.6	400	563.6	400	—	—	—	—	—	—	—	—
		575-60	518	633	289.0	300	456.6	300	—	—	—	—	—	—	—	—
		380-60	342	418	422.8	450	676.2	450	—	—	—	—	—	—	—	—
	B	208/230-60	187	253	802.4	1000	1244.6	1000	—	—	—	—	—	—	—	—
		460-60	414	506	355.6	400	563.6	400	—	—	—	—	—	—	—	—
		575-60	518	633	289.0	300	456.6	300	—	—	—	—	—	—	—	—
		380-60	342	418	422.8	450	676.2	450	—	—	—	—	—	—	—	—
345	A	208/230-60	187	253	802.4	1000	1244.6	1000	—	—	—	—	—	—	—	—
		460-60	414	506	355.6	400	563.6	400	—	—	—	—	—	—	—	—
		575-60	518	633	289.0	300	456.6	300	—	—	—	—	—	—	—	—
		380-60	342	418	422.8	450	676.2	450	—	—	—	—	—	—	—	—
	B	208/230-60	187	253	802.4	1000	1244.6	1000	—	—	—	—	—	—	—	—
		460-60	414	506	355.6	400	563.6	400	—	—	—	—	—	—	—	—
		575-60	518	633	289.0	300	456.6	300	—	—	—	—	—	—	—	—
		380-60	342	418	422.8	450	676.2	450	—	—	—	—	—	—	—	—
360	A	208/230-60	187	253	920.5	1000	1362.7	1000	—	—	—	—	—	—	—	—
		460-60	414	506	408.0	450	616.0	450	—	—	—	—	—	—	—	—
		575-60	518	633	331.5	350	499.1	350	—	—	—	—	—	—	—	—
		380-60	342	418	485.2	500	738.5	500	—	—	—	—	—	—	—	—
	B	208/230-60	187	253	802.4	1000	1244.6	1000	—	—	—	—	—	—	—	—
		460-60	414	506	355.6	400	563.6	400	—	—	—	—	—	—	—	—
		575-60	518	633	289.0	300	456.6	300	—	—	—	—	—	—	—	—
		380-60	342	418	422.8	450	676.2	450	—	—	—	—	—	—	—	—
390	A	208/230-60	187	253	920.5	1000	1362.7	1000	—	—	—	—	—	—	—	—
		460-60	414	506	408.0	450	616.0	450	—	—	—	—	—	—	—	—
		575-60	518	633	331.5	350	499.1	350	—	—	—	—	—	—	—	—
		380-60	342	418	485.2	500	738.5	500	—	—	—	—	—	—	—	—
	B	208/230-60	187	253	920.5	1000	1362.7	1000	—	—	—	—	—	—	—	—
		460-60	414	506	408.0	450	616.0	450	—	—	—	—	—	—	—	—
		575-60	518	633	331.5	350	499.1	350	—	—	—	—	—	—	—	—
		380-60	342	418	485.2	500	738.5	500	—	—	—	—	—	—	—	—

LEGEND

ICF — Instantaneous Current Flow **MOCP** — Maximum Overcurrent Protection
MCA — Minimum Circuit Amps **XL** — Across-the-Line Start

NOTES:

- Units are suitable for use on electrical systems where voltage supplied to the unit terminals is not below or above the listed minimum and maximum limits. Maximum allowable phase imbalance is: voltage, 2%; amps 10%.
- All units/modules have single point primary power connection. (Each unit/module requires its own power supply.) Main power must be supplied from a field-supplied disconnect.
- Cooler heater is wired into the control circuit so it is always operable as long as the power supply disconnect is on, even if any safety device is open.
- For MCA that is less than or equal to 380 amps, 3 conductors are required.
 For MCA between 381-760 amps, 6 conductors are required.
 For MCA between 761-1140 amps, 9 conductors are required.
 For MCA between 1141-1520 amps, 12 conductors are required.
 Calculation of conductors required is based on 75 C copper wire.

- Wiring for main field supply must be rated 75 C minimum. Use copper for all units.
 - Incoming wire size range for the terminal block is #4 AWG to 500 kcmil.
 - Incoming wire size range of non-fused disconnect with MCA up to 599.9 amps is 3/0 to 500 kcmil.
 - Incoming wire size range of non-fused disconnect with MCA from 600 to 799.9 amps is 1/0 to 500 kcmil.
 - Incoming wire size range of non-fused disconnect with MCA from 800 to 1199.9 amps is 250 kcmil to 500 kcmil.
- Hydronic pump packages are not available as a factory-installed option for units 30RB210-390.
- Power draw includes both crankcase heaters and cooler heaters (where used). Each compressor has a crankcase heater which draws 56 watts of power. Units ordered with the cooler heater option have 1 (060-150) or 2 (160-300) cooler heaters, 825 watts each.



Table 8 — 30RB Electrical Data — Single Point Units (cont)

UNIT 30RB	UNIT VOLTAGE		7.5 HP PUMP, 1750/3450 RPM					10 HP PUMP, 3450 RPM				15 HP PUMP, 3450 RPM			
	V-Hz (3 Ph)	Supplied		MCA	MOCP	ICF	Rec Fuse Size	MCA	MOCP	ICF	Rec Fuse Size	MCA	MOCP	ICF	Rec Fuse Size
		Min	Max	XL	XL	XL		XL	XL	XL		XL	XL	XL	
060	208/230-60	187	253	317.2	350	708.5	350	325.1	400	716.4	350	—	—	—	—
	460-60	414	506	139.5	150	313.6	150	143.1	175	317.2	175	—	—	—	—
	575-60	518	633	111.7	125	254.0	125	114.6	125	256.9	125	—	—	—	—
	380-60	342	418	165.0	200	376.9	175	169.3	200	381.3	200	—	—	—	—
070	208/230-60	187	253	360.4	450	802.7	400	368.3	450	810.6	400	—	—	—	—
	460-60	414	506	159.5	200	367.5	175	163.1	200	371.1	175	—	—	—	—
	575-60	518	633	129.0	150	296.7	150	131.9	150	299.6	150	—	—	—	—
	380-60	342	418	189.5	225	442.8	225	193.9	225	447.2	225	—	—	—	—
080	208/230-60	187	253	392.2	450	783.5	450	400.1	450	791.4	450	416.3	450	807.6	450
	460-60	414	506	172.2	200	346.3	200	175.8	200	349.9	200	183.1	200	357.2	200
	575-60	518	633	137.9	150	280.2	150	140.8	150	283.1	150	146.6	150	288.9	150
	380-60	342	418	203.4	225	415.3	225	207.7	225	419.7	225	216.6	250	428.5	250
090	208/230-60	187	253	459.3	500	901.6	500	467.2	500	909.5	500	483.4	500	925.7	500
	460-60	414	506	203.0	225	411.0	225	206.6	225	414.6	225	213.9	250	421.9	225
	575-60	518	633	163.9	175	331.5	175	166.8	200	334.4	200	172.6	200	340.2	200
	380-60	342	418	241.0	250	494.3	250	245.3	250	498.7	250	254.2	300	507.5	300
100	208/230-60	187	253	497.7	500	940.0	500	505.6	600	947.9	600	521.8	600	964.1	600
	460-60	414	506	220.8	250	428.8	250	224.4	250	432.4	250	231.7	250	439.7	250
	575-60	518	633	179.3	200	346.9	200	182.2	200	349.8	200	188.0	200	355.6	200
	380-60	342	418	262.8	300	516.1	300	267.1	300	520.5	300	276.0	300	529.3	300
110	208/230-60	187	253	534.3	600	976.6	600	542.2	600	984.5	600	558.4	600	1000.7	600
	460-60	414	506	235.7	250	443.7	250	239.3	250	447.3	250	246.6	250	454.6	250
	575-60	518	633	190.1	200	357.7	200	193.0	225	360.6	225	198.8	225	366.4	225
	380-60	342	418	279.4	300	532.7	300	283.7	300	537.1	300	292.6	300	545.9	300
120	208/230-60	187	253	615.7	700	1058.0	700	623.7	700	1065.9	700	639.8	700	1082.1	700
	460-60	414	506	273.2	300	481.2	300	276.8	300	484.8	300	284.1	300	492.1	300
	575-60	518	633	221.8	250	389.5	250	224.7	250	392.4	250	230.5	250	398.2	250
	380-60	342	418	325.2	350	578.5	350	329.5	350	582.9	350	338.4	350	591.7	350
130	208/230-60	187	253	652.3	700	1094.6	700	660.3	700	1102.5	700	676.4	700	1118.7	700
	460-60	414	506	288.1	300	496.1	300	291.7	300	499.7	300	299.0	300	507.0	300
	575-60	518	633	232.6	250	400.3	250	235.5	250	403.2	250	241.3	250	409.0	250
	380-60	342	418	341.8	350	595.1	350	346.1	350	599.5	350	355.0	400	608.3	400
150	208/230-60	187	253	709.9	800	1152.2	800	717.9	800	1160.1	800	734.0	800	1176.3	800
	460-60	414	506	314.8	350	522.8	350	318.4	350	526.4	350	325.7	350	533.7	350
	575-60	518	633	255.7	300	423.4	300	258.6	300	426.3	300	264.4	300	432.1	300
	380-60	342	418	374.5	400	627.8	400	378.8	400	632.2	400	387.7	400	641.0	400
160	208/230-60	187	253	770.4	800	1212.7	800	778.4	800	1220.6	800	794.5	800	1236.8	800
	460-60	414	506	340.5	350	548.5	350	344.1	350	552.1	350	351.4	400	559.4	400
	575-60	518	633	275.2	300	442.8	300	278.0	300	445.7	300	283.9	300	451.5	300
	380-60	342	418	404.1	450	657.5	450	408.5	450	661.9	450	417.3	450	670.7	450
170	208/230-60	187	253	828.0	1000	1270.3	1000	836.0	1000	1278.2	1000	852.1	1000	1294.4	1000
	460-60	414	506	367.2	400	575.2	400	370.8	400	578.8	400	378.1	400	586.1	400
	575-60	518	633	298.3	300	465.9	300	301.1	350	468.8	350	307.0	350	474.6	350
	380-60	342	418	436.8	450	690.2	450	441.2	450	694.6	450	450.0	500	703.4	500
190	208/230-60	187	253	946.1	1000	1388.4	1000	954.1	1000	1396.3	1000	970.2	1000	1412.5	1000
	460-60	414	506	419.6	450	627.6	450	423.2	450	631.2	450	430.5	450	638.5	450
	575-60	518	633	340.8	350	508.4	350	343.7	350	511.3	350	349.5	350	517.1	350
	380-60	342	418	499.2	500	752.5	500	503.6	600	756.9	600	512.4	600	765.7	600

LEGEND

ICF — Instantaneous Current Flow **MOCP** — Maximum Overcurrent Protection
MCA — Minimum Circuit Amps **XL** — Across-the-Line Start

NOTES:

- Units are suitable for use on electrical systems where voltage supplied to the unit terminals is not below or above the listed minimum and maximum limits. Maximum allowable phase imbalance is: voltage, 2%; amps 10%.
- All units/modules have single point primary power connection. (Each unit/module requires its own power supply.) Main power must be supplied from a field-supplied disconnect.
- Cooler heater is wired into the control circuit so it is always operable as long as the power supply disconnect is on, even if any safety device is open.
- For MCA that is less than or equal to 380 amps, 3 conductors are required.
 For MCA between 381-760 amps, 6 conductors are required.
 For MCA between 761-1140 amps, 9 conductors are required.
 For MCA between 1141-1520 amps, 12 conductors are required.
 Calculation of conductors required is based on 75 C copper wire.

- Wiring for main field supply must be rated 75 C minimum. Use copper for all units.
 - Incoming wire size range for the terminal block is #4 AWG to 500 kcmil.
 - Incoming wire size range of non-fused disconnect with MCA up to 599.9 amps is 3/0 to 500 kcmil.
 - Incoming wire size range of non-fused disconnect with MCA from 600 to 799.9 amps is 1/0 to 500 kcmil.
 - Incoming wire size range of non-fused disconnect with MCA from 800 to 1199.9 amps is 250 kcmil to 500 kcmil.
- Hydronic pump packages are not available as a factory-installed option for units 30RB210-390.
- Power draw includes both crankcase heaters and cooler heaters (where used). Each compressor has a crankcase heater which draws 56 watts of power. Units ordered with the cooler heater option have 1 (060-150) or 2 (160-300) cooler heaters, 825 watts each.



208/230
460
575 v only

Table 9 — 30RB Electrical Data — Dual Point Units

UNIT 30RB	UNIT VOLTAGE		NO HYDRONIC PACKAGE				3 HP PUMP, 1750 RPM				5 HP PUMP, 1750 RPM			
	V-Hz (3 Ph)	Supplied	MCA	MOCP	ICF	Rec Fuse Size	MCA	MOCP	ICF	Rec Fuse Size	MCA	MOCP	ICF	Rec Fuse Size
		Min												
060	208/230-60	187 253	168.8/141.5	225/200	560.0/532.8	200/175	179.6/141.5	250/200	570.8/532.8	200/175	186.4/141.5	250/200	577.7/532.8	225/175
	460-60	414 506	73.6/ 62.5	100/ 90	247.7/236.6	90/ 80	78.5/ 62.5	110/ 90	252.6/236.6	90/ 80	81.6/ 62.5	110/ 90	255.7/236.6	90/ 80
	575-60	518 633	59.0/ 50.0	80/ 70	201.2/192.3	70/ 60	62.9/ 50.0	80/ 70	205.1/192.3	70/ 60	65.4/ 50.0	90/ 70	207.6/192.3	80/ 60
	380-60	342 418	86.4/ 74.1	110/110	298.4/286.1	100/ 90	92.3/ 74.1	125/110	304.3/286.1	110/ 90	96.1/ 74.1	125/110	308.1/286.1	110/ 90
070	208/230-60	187 253	212.0/141.5	300/200	579.2/607.8	250/175	222.8/141.5	300/200	590.0/607.8	250/175	229.6/141.5	300/200	596.9/607.8	300/175
	460-60	414 506	93.6/ 62.5	125/ 90	256.6/281.6	110/ 80	98.5/ 62.5	125/ 90	261.5/281.6	110/ 80	101.6/ 62.5	125/ 90	264.6/281.6	125/ 80
	575-60	518 633	76.3/ 50.0	110/ 70	208.9/227.3	90/ 60	80.2/ 50.0	110/ 70	212.8/227.3	90/ 60	82.7/ 50.0	110/ 70	215.3/227.3	100/ 60
	380-60	342 418	110.9/ 74.1	150/110	309.3/341.1	125/ 90	116.9/ 74.1	150/110	315.2/341.1	150/ 90	120.6/ 74.1	150/110	319.0/341.1	150/ 90
080	208/230-60	187 253	216.5/168.8	250/225	607.8/560.0	250/200	—	—	—	—	234.2/168.8	300/225	625.5/560.0	300/200
	460-60	414 506	95.2/ 73.6	125/100	269.3/247.7	110/ 90	—	—	—	—	103.2/ 73.6	125/100	277.3/247.7	125/ 90
	575-60	518 633	76.2/ 59.0	100/ 80	218.5/201.2	90/ 70	—	—	—	—	82.6/ 59.0	100/ 80	224.9/201.2	90/ 70
	380-60	342 418	112.5/ 86.4	150/110	324.5/298.4	125/100	—	—	—	—	122.2/ 86.4	150/110	334.2/298.4	150/100
090	208/230-60	187 253	283.6/168.8	350/225	725.9/635.0	350/200	—	—	—	—	301.3/168.8	350/225	743.6/635.0	350/200
	460-60	414 506	126.0/ 73.6	150/100	334.0/292.7	150/ 90	—	—	—	—	134.0/ 73.6	175/100	342.0/292.7	150/ 90
	575-60	518 633	102.2/ 59.0	125/ 80	269.8/236.2	125/ 70	—	—	—	—	108.6/ 59.0	125/ 80	276.2/236.2	125/ 70
	380-60	342 418	150.1/ 86.4	175/110	403.5/353.4	175/100	—	—	—	—	159.8/ 86.4	200/110	413.2/353.4	175/100
100	208/230-60	187 253	283.6/212.0	350/300	725.9/654.2	350/250	—	—	—	—	301.3/212.0	350/300	743.6/654.2	350/250
	460-60	414 506	126.0/ 93.6	150/125	334.0/301.6	150/110	—	—	—	—	134.0/ 93.6	175/125	342.0/301.6	150/110
	575-60	518 633	102.2/ 76.3	125/110	269.8/243.9	125/ 90	—	—	—	—	108.6/ 76.3	125/110	276.2/243.9	125/ 90
	380-60	342 418	150.1/110.9	175/150	403.5/364.3	175/125	—	—	—	—	159.8/110.9	200/150	413.2/364.3	175/125
110	208/230-60	187 253	283.6/243.8	350/300	725.9/710.0	350/300	—	—	—	—	301.3/243.8	350/300	743.6/710.0	350/300
	460-60	414 506	126.0/106.3	150/125	334.0/325.4	150/125	—	—	—	—	134.0/106.3	175/125	342.0/325.4	150/125
	575-60	518 633	102.2/ 85.2	125/110	269.8/262.4	125/100	—	—	—	—	108.6/ 85.2	125/110	276.2/262.4	125/100
	380-60	342 418	150.1/124.8	175/150	403.5/391.8	175/150	—	—	—	—	159.8/124.8	200/150	413.2/391.8	175/150
120	208/230-60	187 253	259.7/342.0	350/400	607.8/560.0	300/400	—	—	—	—	277.4/342.0	350/400	719.7/784.2	350/400
	460-60	414 506	115.2/151.4	150/175	323.2/359.4	150/175	—	—	—	—	123.2/151.4	150/175	331.2/359.4	150/175
	575-60	518 633	93.6/123.1	125/150	261.2/290.8	110/150	—	—	—	—	100.0/123.1	125/150	267.6/290.8	110/150
	380-60	342 418	137.1/179.8	175/225	390.4/433.2	150/200	—	—	—	—	146.8/179.8	175/225	400.1/433.2	175/200
130	208/230-60	187 253	401.7/243.8	450/300	843.9/710.0	450/300	—	—	—	—	419.4/243.8	500/300	861.6/710.0	450/300
	460-60	414 506	178.4/106.3	200/125	386.4/325.4	200/125	—	—	—	—	186.4/106.3	225/125	394.4/325.4	200/125
	575-60	518 633	144.7/ 85.2	175/110	312.4/262.4	175/100	—	—	—	—	151.1/ 85.2	175/110	318.8/262.4	175/100
	380-60	342 418	212.5/124.8	250/150	465.9/391.8	225/150	—	—	—	—	222.2/124.8	250/150	475.6/391.8	250/150
150	208/230-60	187 253	401.7/306.2	450/400	843.9/748.4	450/350	—	—	—	—	419.4/306.2	500/400	861.6/748.4	450/350
	460-60	414 506	178.4/135.2	200/175	386.4/343.2	200/150	—	—	—	—	186.4/135.2	225/175	394.4/343.2	200/150
	575-60	518 633	144.7/110.2	175/125	312.4/277.8	175/125	—	—	—	—	151.1/110.2	175/125	318.8/277.8	175/125
	380-60	342 418	212.5/160.2	250/200	465.9/413.6	225/175	—	—	—	—	222.2/160.2	250/200	475.6/413.6	250/175
160	208/230-60	187 253	519.8/243.8	600/300	962.0/710.0	600/300	—	—	—	—	537.5/243.8	600/300	979.7/710.0	600/300
	460-60	414 506	230.8/106.3	250/125	438.8/325.4	250/125	—	—	—	—	238.8/106.3	250/125	446.8/325.4	250/125
	575-60	518 633	187.3/ 85.2	200/110	354.9/262.4	200/100	—	—	—	—	193.7/ 85.2	225/110	361.3/262.4	225/100
	380-60	342 418	274.9/124.8	300/150	528.3/391.8	300/150	—	—	—	—	284.6/124.8	300/150	538.0/391.8	300/150
170	208/230-60	187 253	519.8/306.2	600/400	962.0/748.4	600/350	—	—	—	—	537.5/306.2	600/400	979.7/748.4	600/350
	460-60	414 506	230.8/135.2	250/175	438.8/343.2	250/150	—	—	—	—	238.8/135.2	250/175	446.8/343.2	250/150
	575-60	518 633	187.3/110.2	200/125	354.9/277.8	200/125	—	—	—	—	193.7/110.2	225/125	361.3/277.8	225/125
	380-60	342 418	274.9/160.2	300/200	528.3/413.6	300/175	—	—	—	—	284.6/160.2	300/200	538.0/413.6	300/175
190	208/230-60	187 253	543.7/400.4	600/450	985.9/842.6	600/450	—	—	—	—	561.4/400.4	600/450	1003.6/842.6	600/450
	460-60	414 506	241.6/176.8	250/200	449.8/384.8	250/200	—	—	—	—	249.6/176.8	250/200	457.6/384.8	250/200
	575-60	518 633	195.9/144.1	225/175	363.5/311.7	225/175	—	—	—	—	202.3/144.1	225/175	369.9/311.7	225/175
	380-60	342 418	288.0/209.5	300/250	541.3/462.9	300/225	—	—	—	—	297.7/209.5	300/250	551.0/462.9	300/225
210	208/230-60	187 253	626.7/353.9	700/400	1068.9/796.2	700/400	—	—	—	—	—	—	—	—
	460-60	414 506	276.5/156.8	300/175	484.5/364.8	300/175	—	—	—	—	—	—	—	—
	575-60	518 633	223.3/127.5	250/150	391.0/295.1	250/150	—	—	—	—	—	—	—	—
	380-60	342 418	327.7/186.4	350/225	581.1/439.7	350/200	—	—	—	—	—	—	—	—
225	208/230-60	187 253	684.3/353.9	700/400	1126.5/796.2	700/400	—	—	—	—	—	—	—	—
	460-60	414 506	303.2/156.8	350/175	511.2/364.8	350/175	—	—	—	—	—	—	—	—
	575-60	518 633	246.4/127.5	250/150	414.1/295.1	250/150	—	—	—	—	—	—	—	—
	380-60	342 418	360.4/186.4	400/225	613.8/439.7	400/200	—	—	—	—	—	—	—	—
250	208/230-60	187 253	684.3/472.0	700/500	1126.5/914.3	700/500	—	—	—	—	—	—	—	—
	460-60	414 506	303.2/209.2	350/250	511.2/417.2	350/225	—	—	—	—	—	—	—	—
	575-60	518 633	246.4/170.0	250/200	414.1/337.6	250/200	—	—	—	—	—	—	—	—
	380-60	342 418	360.4/248.7	400/250	613.8/502.1	400/250	—	—	—	—	—	—	—	—
275	208/230-60	187 253	920.5/353.9	1000/400	1362.7/796.2	1000/400	—	—	—	—	—	—	—	—
	460-60	414 506	408.0/156.8	450/175	616.0/364.8	450/175	—	—	—	—	—	—	—	—
	575-60	518 633	331.5/127.5	350/150	499.1/295.1	350/150	—	—	—	—	—	—	—	—
	380-60	342 418	485.2/186.4	500/225	738.5/439.7	500/200	—	—	—	—	—	—	—	—
300	208/230-60	187 253	920.5/472.0	1000/500	1362.7/914.3	1000/500	—	—	—	—	—	—	—	—
	460-60	414 506	408.0/209.2	450/250	616.0/417.2	450/225	—	—	—	—	—	—	—	—
	575-60	518 633	331.5/170.0	350/200	499.1/337.6	350/200	—	—	—	—	—	—	—	—
	380-60	342 418	485.2/248.7	500/2										

Table 9 — 30RB Electrical Data — Dual Point Units (cont)

UNIT 30RB	UNIT VOLTAGE			NO HYDRONIC PACKAGE				3 HP PUMP, 1750 RPM				5 HP PUMP, 1750 RPM				
	V-Hz (3 Ph)	Supplied		MCA	MOCP	ICF	Rec Fuse Size	MCA	MOCP	ICF	Rec Fuse Size	MCA	MOCP	ICF	Rec Fuse Size	
		Min	Max													
315	A	208/230-60	187	253	519.8/243.8	600/300	962.0/710.0	600/300	—	—	—	—	—	—	—	—
		460-60	414	506	230.8/106.3	250/125	438.8/325.4	250/125	—	—	—	—	—	—	—	—
		575-60	518	633	187.3/ 85.2	200/110	354.9/262.4	200/100	—	—	—	—	—	—	—	—
		380-60	342	418	274.9/124.8	300/150	528.3/391.8	300/150	—	—	—	—	—	—	—	—
	B	208/230-60	187	253	519.8/243.8	600/300	962.0/710.0	600/300	—	—	—	—	—	—	—	—
		460-60	414	506	230.8/106.3	250/125	438.8/325.4	250/125	—	—	—	—	—	—	—	—
		575-60	518	633	187.3/ 85.2	200/110	354.9/262.4	200/100	—	—	—	—	—	—	—	—
		380-60	342	418	274.9/124.8	300/150	528.3/391.8	300/150	—	—	—	—	—	—	—	—
330	A	208/230-60	187	253	519.8/306.2	600/400	962.0/748.4	600/350	—	—	—	—	—	—	—	—
		460-60	414	506	230.8/135.2	250/175	438.8/343.2	250/150	—	—	—	—	—	—	—	—
		575-60	518	633	187.3/110.2	200/125	354.9/277.8	200/125	—	—	—	—	—	—	—	—
		380-60	342	418	274.9/160.2	300/200	528.3/413.6	300/175	—	—	—	—	—	—	—	—
	B	208/230-60	187	253	519.8/243.8	600/300	962.0/710.0	600/300	—	—	—	—	—	—	—	—
		460-60	414	506	230.8/106.3	250/125	438.8/325.4	250/125	—	—	—	—	—	—	—	—
		575-60	518	633	187.3/ 85.2	200/110	354.9/262.4	200/100	—	—	—	—	—	—	—	—
		380-60	342	418	274.9/124.8	300/150	528.3/391.8	300/150	—	—	—	—	—	—	—	—
345	A	208/230-60	187	253	519.8/306.2	600/400	962.0/748.4	600/350	—	—	—	—	—	—	—	—
		460-60	414	506	230.8/135.2	250/175	438.8/343.2	250/150	—	—	—	—	—	—	—	—
		575-60	518	633	187.3/110.2	200/125	354.9/277.8	200/125	—	—	—	—	—	—	—	—
		380-60	342	418	274.9/160.2	300/200	528.3/413.6	300/175	—	—	—	—	—	—	—	—
	B	208/230-60	187	253	519.8/306.2	600/400	962.0/748.4	600/350	—	—	—	—	—	—	—	—
		460-60	414	506	230.8/135.2	250/175	438.8/343.2	250/150	—	—	—	—	—	—	—	—
		575-60	518	633	187.3/110.2	200/125	354.9/277.8	200/125	—	—	—	—	—	—	—	—
		380-60	342	418	274.9/160.2	300/200	528.3/413.6	300/175	—	—	—	—	—	—	—	—
360	A	208/230-60	187	253	543.7/400.4	600/450	985.9/842.6	600/450	—	—	—	—	—	—	—	—
		460-60	414	506	241.6/176.8	250/200	449.6/384.8	250/200	—	—	—	—	—	—	—	—
		575-60	518	633	195.9/144.1	225/175	363.5/311.7	225/175	—	—	—	—	—	—	—	—
		380-60	342	418	288.0/209.5	300/250	541.3/462.9	300/225	—	—	—	—	—	—	—	—
	B	208/230-60	187	253	519.8/306.2	600/400	962.0/748.4	600/350	—	—	—	—	—	—	—	—
		460-60	414	506	230.8/135.2	250/175	438.8/343.2	250/150	—	—	—	—	—	—	—	—
		575-60	518	633	187.3/110.2	200/125	354.9/277.8	200/125	—	—	—	—	—	—	—	—
		380-60	342	418	274.9/160.2	300/200	528.3/413.6	300/175	—	—	—	—	—	—	—	—
390	A	208/230-60	187	253	543.7/400.4	600/450	985.9/842.6	600/450	—	—	—	—	—	—	—	—
		460-60	414	506	241.6/176.8	250/200	449.6/384.8	250/200	—	—	—	—	—	—	—	—
		575-60	518	633	195.9/144.1	225/175	363.5/311.7	225/175	—	—	—	—	—	—	—	—
		380-60	342	418	288.0/209.5	300/250	541.3/462.9	300/225	—	—	—	—	—	—	—	—
	B	208/230-60	187	253	543.7/400.4	600/450	985.9/842.6	600/450	—	—	—	—	—	—	—	—
		460-60	414	506	241.6/176.8	250/200	449.6/384.8	250/200	—	—	—	—	—	—	—	—
		575-60	518	633	195.9/144.1	225/175	363.5/311.7	225/175	—	—	—	—	—	—	—	—
		380-60	342	418	288.0/209.5	300/250	541.3/462.9	300/225	—	—	—	—	—	—	—	—

LEGEND

ICF — Instantaneous Current Flow (Ckt1/Ckt2)
MCA — Minimum Circuit Amps (Ckt1/Ckt2)
MOCP — Maximum Overcurrent Protection (Ckt1/Ckt2)
XL — Across-the-Line Start

NOTES:

- Units are suitable for use on electrical systems where voltage supplied to the unit terminals is not below or above the listed minimum and maximum limits. Maximum allowable phase imbalance is: voltage, 2%; amps 10%.
- All units/modules have single point primary power connection. (Each unit/module requires its own power supply.) Main power must be supplied from a field-supplied disconnect.
- Cooler heater is wired into the control circuit so it is always operable as long as the power supply disconnect is on, even if any safety device is open.
- For MCA that is less than or equal to 380 amps, 3 conductors are required.
 For MCA between 381-760 amps, 6 conductors are required.
 For MCA between 761-1140 amps, 9 conductors are required.
 For MCA between 1141-1520 amps, 12 conductors are required.
 Calculation of conductors required is based on 75 C copper wire.

- Wiring for main field supply must be rated 75 C minimum. Use copper for all units.
 - Incoming wire size range for the terminal block is #4 AWG to 500 kcmil.
 - Incoming wire size range of non-fused disconnect with MCA up to 599.9 amps is 3/0 to 500 kcmil.
 - Incoming wire size range of non-fused disconnect with MCA from 600 to 799.9 amps is 1/0 to 500 kcmil.
 - Incoming wire size range of non-fused disconnect with MCA from 800 to 1199.9 amps is 250 kcmil to 500 kcmil.
- Hydronic pump packages are not available as a factory-installed option for units 30RB210-390.
- Power draw includes both crankcase heaters and cooler heaters (where used). Each compressor has a crankcase heater which draws 56 watts of power. Units ordered with the cooler heater option have 1 (060-150) or 2 (160-300) cooler heaters, 825 watts each.



Table 9 — 30RB Electrical Data — Dual Point Units (cont)

UNIT 30RB	UNIT VOLTAGE		7.5 HP PUMP, 1750/3450 RPM				10 HP PUMP, 3450 RPM				15 HP PUMP, 3450 RPM				
	V-Hz (3 Ph)	Supplied		MCA	MOCP	ICF	Rec Fuse Size	MCA	MOCP	ICF	Rec Fuse Size	MCA	MOCP	ICF	Rec Fuse Size
		Min	Max												
060	208/230-60	187	253	194.4/141.5	250/200	585.7/532.8	225/175	202.4/141.5	250/200	593.6/532.8	225/175	—	—	—	—
	460-60	414	506	85.2/ 62.5	110/ 90	259.3/236.6	100/ 80	88.8/ 62.5	110/ 90	262.9/236.6	100/ 80	—	—	—	—
	575-60	518	633	68.2/ 50.0	90/ 70	210.5/192.3	80/ 60	71.1/ 50.0	90/ 70	213.4/192.3	80/ 60	—	—	—	—
	380-60	342	418	100.4/ 74.1	125/110	312.4/286.1	125/ 90	104.8/ 74.1	125/110	316.8/286.1	125/ 90	—	—	—	—
070	208/230-60	187	253	237.6/141.5	300/200	604.9/607.8	300/175	245.6/141.5	300/200	612.8/607.8	300/175	—	—	—	—
	460-60	414	506	105.2/ 62.5	125/ 90	268.2/281.6	125/ 80	108.8/ 62.5	150/ 90	271.8/281.6	125/ 80	—	—	—	—
	575-60	518	633	85.6/ 50.0	110/ 70	218.2/227.3	100/ 60	88.4/ 50.0	110/ 70	221.1/227.3	100/ 60	—	—	—	—
	380-60	342	418	125.0/ 74.1	150/110	323.3/341.1	150/ 90	129.3/ 74.1	175/ 110	327.7/341.1	150/ 90	—	—	—	—
080	208/230-60	187	253	242.2/168.8	300/225	633.5/560.0	300/200	250.1/168.8	300/225	641.4/560.0	300/200	266.3/168.8	300/225	657.6/560.0	300/200
	460-60	414	506	106.8/ 73.6	125/100	280.9/247.7	125/ 90	110.4/ 73.6	125/100	284.5/247.7	125/ 90	117.7/ 73.6	150/100	291.8/247.7	150/ 90
	575-60	518	633	85.5/ 59.0	110/ 80	227.8/201.2	100/ 70	88.4/ 59.0	110/ 80	230.7/201.2	100/ 70	94.2/ 59.0	110/ 80	236.5/201.2	110/ 70
	380-60	342	418	126.6/ 86.4	150/110	338.5/298.4	150/100	130.9/ 86.4	150/110	342.9/298.4	150/100	139.8/ 86.4	175/110	351.7/298.4	150/100
090	208/230-60	187	253	309.3/168.8	400/225	751.6/635.0	350/200	317.2/168.8	400/225	759.5/635.0	350/200	333.4/168.8	400/225	775.7/635.0	400/200
	460-60	414	506	137.6/ 73.6	175/100	345.6/292.7	150/ 90	141.2/ 73.6	175/100	349.2/292.7	175/ 90	148.5/ 73.6	175/100	356.5/292.7	175/ 90
	575-60	518	633	111.5/ 59.0	125/ 80	279.1/236.2	125/ 70	114.4/ 59.0	125/ 80	282.0/236.2	125/ 70	120.2/ 59.0	150/ 80	287.8/236.2	150/ 70
	380-60	342	418	164.2/ 86.4	200/110	417.5/353.4	200/100	168.5/ 86.4	200/110	421.9/353.4	200/100	177.4/ 86.4	225/110	430.7/353.4	200/100
100	208/230-60	187	253	309.3/212.0	400/300	751.6/654.2	350/250	317.2/212.0	400/300	759.5/654.2	350/250	333.4/212.0	400/300	775.7/654.2	400/250
	460-60	414	506	137.6/ 93.6	175/125	345.6/301.6	150/110	141.2/ 93.6	175/125	349.2/301.6	175/110	148.5/ 93.6	175/125	356.5/301.6	175/110
	575-60	518	633	111.5/ 76.3	125/110	279.1/243.9	125/ 90	114.4/ 76.3	125/110	282.0/243.9	125/ 90	120.2/ 76.3	150/110	287.8/243.9	150/ 90
	380-60	342	418	164.2/110.9	200/150	417.5/364.3	200/150	168.5/110.9	200/150	421.9/364.3	200/125	177.4/110.9	225/150	430.7/364.3	200/125
110	208/230-60	187	253	309.3/243.8	400/300	751.6/710.0	350/300	317.2/243.8	400/300	759.5/710.0	350/300	333.4/243.8	400/300	775.7/710.0	400/300
	460-60	414	506	137.6/106.3	175/125	345.6/325.4	150/125	141.2/106.3	175/125	349.2/325.4	175/125	148.5/106.3	175/125	356.5/325.4	175/125
	575-60	518	633	111.5/ 85.2	125/110	279.1/262.4	125/100	114.4/ 85.2	125/110	282.0/262.4	125/100	120.2/ 85.2	150/110	287.8/262.4	150/100
	380-60	342	418	164.2/124.8	200/150	417.5/391.8	200/150	168.5/124.8	200/150	421.9/391.8	200/150	177.4/124.8	225/150	430.7/391.8	200/150
120	208/230-60	187	253	285.4/342.0	350/400	727.7/7784.2	350/400	293.3/342.0	350/400	735.6/784.2	350/400	309.5/342.0	400/400	751.8/784.2	350/400
	460-60	414	506	126.8/151.4	150/175	334.8/359.4	150/175	130.4/151.4	150/175	338.4/359.4	150/175	137.7/151.4	175/175	345.7/359.4	150/175
	575-60	518	633	102.8/123.1	125/150	270.5/290.8	125/150	105.7/123.1	125/150	273.4/290.8	125/150	111.6/123.1	125/150	279.2/290.8	125/150
	380-60	342	418	151.1/179.8	200/225	404.4/433.2	175/200	155.5/179.8	200/225	408.8/433.2	175/200	164.3/179.8	200/225	417.6/433.2	200/200
130	208/230-60	187	253	427.3/243.8	500/300	869.6/7710.0	500/300	435.3/243.8	500/300	877.5/7710.0	500/300	451.4/243.8	500/300	893.7/7710.0	500/300
	460-60	414	506	190.0/106.3	225/125	398.0/325.4	225/125	193.6/106.3	225/125	401.6/325.4	225/125	200.9/106.3	225/125	408.9/325.4	225/125
	575-60	518	633	154.0/ 85.2	175/110	321.7/262.4	175/100	156.9/ 85.2	175/110	324.6/262.4	175/110	162.7/ 85.2	175/110	330.8/262.4	175/100
	380-60	342	418	226.6/124.8	250/150	479.9/391.8	250/150	230.9/124.8	250/150	484.3/391.8	250/150	239.8/124.8	250/150	493.1/391.8	250/150
150	208/230-60	187	253	427.3/306.2	500/400	869.6/748.4	500/350	435.3/306.2	500/400	877.5/748.4	500/350	451.4/306.2	500/400	893.7/748.4	500/350
	460-60	414	506	190.0/135.2	225/175	398.0/343.2	225/150	193.6/135.2	225/175	401.6/343.2	225/150	200.9/135.2	225/175	408.9/343.2	225/150
	575-60	518	633	154.0/110.2	175/125	321.7/277.8	175/125	156.9/110.2	175/125	324.6/277.8	175/125	162.7/110.2	175/125	330.4/277.8	175/125
	380-60	342	418	226.6/160.2	250/200	479.9/413.6	250/175	230.9/160.2	250/200	484.3/413.6	250/175	239.8/160.2	250/200	493.1/413.6	250/175
160	208/230-60	187	253	545.4/243.8	600/300	987.7/7710.0	600/300	553.4/243.8	600/300	995.6/7710.0	600/300	569.5/243.8	600/300	1011.8/7710.0	600/300
	460-60	414	506	242.4/106.3	250/125	450.4/325.4	250/125	246.0/106.3	250/125	454.0/325.4	250/125	253.3/106.3	300/125	461.3/325.4	300/125
	575-60	518	633	196.6/ 85.2	225/110	364.2/262.4	225/100	199.4/ 85.2	225/110	367.1/262.4	225/100	205.3/ 85.2	225/110	372.9/262.4	225/100
	380-60	342	418	288.9/124.8	300/150	542.3/391.8	300/150	293.3/124.8	300/150	546.7/391.8	300/150	302.1/124.8	350/150	555.5/391.8	350/150
170	208/230-60	187	253	545.4/306.2	600/400	987.7/748.4	600/350	553.4/306.2	600/400	995.6/748.4	600/350	569.5/306.2	600/400	1011.8/748.4	600/350
	460-60	414	506	242.4/135.2	250/175	450.4/343.2	250/150	246.0/135.2	250/175	454.0/343.2	250/150	253.3/135.2	300/175	461.3/343.2	300/150
	575-60	518	633	196.6/110.2	225/125	364.2/277.8	225/125	199.4/110.2	225/125	367.1/277.8	225/125	205.3/110.2	225/125	372.9/277.8	225/125
	380-60	342	418	288.9/160.2	300/200	542.3/413.6	300/175	293.3/160.2	300/200	546.7/413.6	300/175	302.1/160.2	350/200	555.5/413.6	350/175
190	208/230-60	187	253	569.3/400.4	600/450	1011.8/842.6	600/450	577.3/400.4	600/450	1019.5/842.6	600/450	593.4/400.4	600/450	1035.7/842.6	600/450
	460-60	414	506	253.2/176.8	300/200	461.2/384.8	300/200	256.8/176.8	300/200	464.8/384.8	300/200	264.1/176.8	300/200	472.1/384.8	300/200
	575-60	518	633	205.2/144.1	225/175	372.8/311.7	225/175	208.1/144.1	225/175	375.7/311.7	225/175	213.9/144.1	225/175	381.5/311.7	225/175
	380-60	342	418	302.0/209.5	350/250	555.3/462.9	350/225	306.4/209.5	350/250	559.7/462.9	350/225	315.2/209.5	350/250	568.5/462.9	350/225

LEGEND

ICF — Instantaneous Current Flow (Ckt1/Ckt2)
MCA — Minimum Circuit Amps (Ckt1/Ckt2)
MOCP — Maximum Overcurrent Protection (Ckt1/Ckt2)
XL — Across-the-Line Start

NOTES:

- Units are suitable for use on electrical systems where voltage supplied to the unit terminals is not below or above the listed minimum and maximum limits. Maximum allowable phase imbalance is: voltage, 2%; amp, 10%.
- All units/modules have single point primary power connection. (Each unit/module requires its own power supply.) Main power must be supplied from a field-supplied disconnect.
- Cooler heater is wired into the control circuit so it is always operable as long as the power supply disconnect is on, even if any safety device is open.
- For MCA that is less than or equal to 380 amps, 3 conductors are required.
 For MCA between 381-760 amps, 6 conductors are required.
 For MCA between 761-1140 amps, 9 conductors are required.
 For MCA between 1141-1520 amps, 12 conductors are required.
 Calculation of conductors required is based on 75 C copper wire.

- Wiring for main field supply must be rated 75 C minimum. Use copper for all units.
 - Incoming wire size range for the terminal block is #4 AWG to 500 kcmil.
 - Incoming wire size range of non-fused disconnect with MCA up to 599.9 amps is 3/0 to 500 kcmil.
 - Incoming wire size range of non-fused disconnect with MCA from 600 to 799.9 amps is 1/0 to 500 kcmil.
 - Incoming wire size range of non-fused disconnect with MCA from 800 to 1199.9 amps is 250 kcmil to 500 kcmil.
- Hydronic pump packages are not available as a factory-installed option for units 30RB210-390.
- Power draw includes both crankcase heaters and cooler heaters (where used). Each compressor has a crankcase heater which draws 56 watts of power. Units ordered with the cooler heater option have 1 (060-150) or 2 (160-300) cooler heaters, 825 watts each.



208/230
460
575 v only

Table 10 — Condenser Fan Electrical Data

UNIT 30RB	UNIT VOLTAGE V-Hz (3 Ph)	STANDARD CONDENSER FANS					
		Circuit A Quantity	FLA (each)	Circuit B Quantity	FLA (each)	Circuit C Quantity	FLA (each)
060, 070	208/230-60	3	11.9	1	11.9	—	—
	460-60	3	5.4	1	5.4	—	—
	575-60	3	4.3	1	4.3	—	—
	380-60	3	6.5	1	6.5	—	—
080	208/230-60	2	11.9	2	11.9	—	—
	460-60	2	5.4	2	5.4	—	—
	575-60	2	4.3	2	4.3	—	—
	380-60	2	6.5	2	6.5	—	—
090, 100, 110	208/230-60	3	11.9	3	11.9	—	—
	460-60	3	5.4	3	5.4	—	—
	575-60	3	4.3	3	4.3	—	—
	380-60	3	6.5	3	6.5	—	—
120	208/230-60	3	11.9	4	11.9	—	—
	460-60	3	5.4	4	5.4	—	—
	575-60	3	4.3	4	4.3	—	—
	380-60	3	6.5	4	6.5	—	—
130, 150	208/230-60	4	11.9	4	11.9	—	—
	460-60	4	5.4	4	5.4	—	—
	575-60	4	4.3	4	4.3	—	—
	380-60	4	6.5	4	6.5	—	—
160,170, 315A, 315B, 330A, 330B, 345A, 345B, 360B	208/230-60	6	11.9	4	11.9	—	—
	460-60	6	5.4	4	5.4	—	—
	575-60	6	4.3	4	4.3	—	—
	380-60	6	6.5	4	6.5	—	—
190, 360A, 390A, 390B	208/230-60	6	11.9	6	11.9	—	—
	460-60	6	5.4	6	5.4	—	—
	575-60	6	4.3	6	4.3	—	—
	380-60	6	6.5	6	6.5	—	—
210, 225	208/230-60	4	11.9	4	11.9	4	11.9
	460-60	4	5.4	4	5.4	4	5.4
	575-60	4	4.3	4	4.3	4	4.3
	380-60	4	6.5	4	6.5	4	6.5
250	208/230-60	4	11.9	4	11.9	6	11.9
	460-60	4	5.4	4	5.4	6	5.4
	575-60	4	4.3	4	4.3	6	4.3
	380-60	4	6.5	4	6.5	6	6.5
275	208/230-60	6	11.9	6	11.9	4	11.9
	460-60	6	5.4	6	5.4	4	5.4
	575-60	6	4.3	6	4.3	4	4.3
	380-60	6	6.5	6	6.5	4	6.5
300	208/230-60	6	11.9	6	11.9	6	11.9
	460-60	6	5.4	6	5.4	6	5.4
	575-60	6	4.3	6	4.3	6	4.3
	380-60	6	6.5	6	6.5	6	6.5

LEGEND

FLA — Full Load Amps

Table 11 — Pump Electrical Data

PUMP HP	UNIT VOLTAGE V-Hz (3 Ph)	HYDRONIC SYSTEM (SINGLE/DUAL) FLA (each)	USED ON 30RB SIZES*
3	208/230-60	10.8	060, 070
	460-60	4.9	
	575-60	3.9	
	380-60	5.9	
5	208/230-60	17.7	060-190
	460-60	8.0	
	575-60	6.4	
	380-60	9.7	
7.5	208/230-60	25.7	060-190
	460-60	11.6	
	575-60	9.3	
	380-60	14.0	
10	208/230-60	33.6	060-190
	460-60	15.2	
	575-60	12.2	
	380-60	18.4	
15	208/230-60	49.8	080-190
	460-60	22.5	
	575-60	18.0	
	380-60	27.2	

*Hydronic pump packages are not available as a factory-installed option for units 30RB210-390.

- NOTES:**
1. Factory wiring is in accordance with UL 1995 standards. Field modifications or additions must be in compliance with all applicable codes.
 2. Wiring for main field supply must be rated 75 C minimum. Use copper for all units.
Incoming wire size range for the terminal block is #4 AWG to 500 kcmil.
Incoming wire size range for non-fused disconnect with MCA up to 599.9 amps is 3/0 to 500 kcmil.
Incoming wire size range of non-fused disconnect with MCA from 600 to 799.9 amps is 1/0 to 500 kcmil.
Incoming wire size range of non-fused disconnect with MCA from 800 to 1199.9 amps is 250 kcmil to 500 kcmil.
 3. Terminals 9 and 10 of TB5 are for field external connections for remote on-off. The contacts must be rated for dry circuit application capable of handling a 24 vac load up to 50 mA.
 4. Terminals 11 and 13 of TB5 are for external connections of chilled water pump interlock. The contacts must be rated for dry circuit application capable of handling a 24 vac load up to 50 mA.
 5. Terminals 11 and 13 of TB5 are for control of chilled water pump1 (PMP1) starter. Terminals 13 and 15 of TB5 are for control of chilled water pump2 (PMP2) starter. The maximum load allowed for the chilled water pump relay is 5 va sealed, 10 va inrush at 24 v. Field power supply is not required.
 6. For control of chilled water pumps, a set of normally open contacts rated for dry circuit application must be supplied from field-supplied pump starter relay. Connect contacts to violet and pink wires in harness from main base board channel 18. Wires in harness are marked PMP1-13 and PMP1-14.
 7. Terminals 12 and 13 of TB5 are for an alarm relay. The maximum load allowed for the alarm relay is 10 va sealed, 25 va inrush at 24 v. Field power supply is not required.
 8. Make appropriate connections to TB6 as shown for energy management board options. The contacts for occupancy overrides demand limit and ice done options must be rated for dry circuit application capable of handling a 24 vac load up to 50 mA.

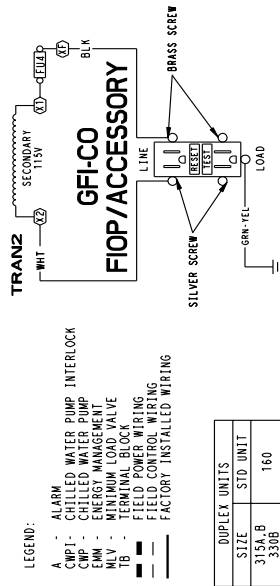

LEGEND:

- A - ALARM
- AWP1 - CHILLED WATER PUMP INTERLOCK
- CWP - CHILLED WATER PUMP
- EMM - ENERGY MANAGEMENT BOARD
- FIOP - FIELD INTERRUPTOR
- TB - TERMINAL BLOCK
- FIELD POWER WIRING
- FIELD CONTROL WIRING
- FACTORY INSTALLED WIRING

DUPLIX UNITS	STD UNIT
315A,B	160
330A	170
345A,B	180
360A	190
390A,B	

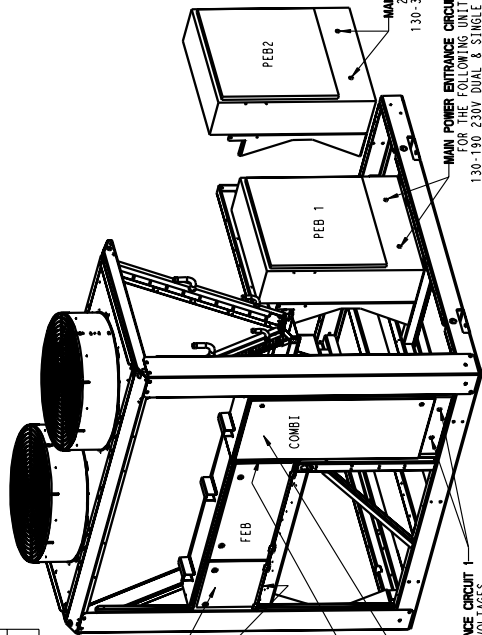

TYPICAL CONTROL BOX LOCATIONS AND MAIN POWER ENTRY

Fig. 46 — Control and Power Wiring Schematic, 30RB060-390

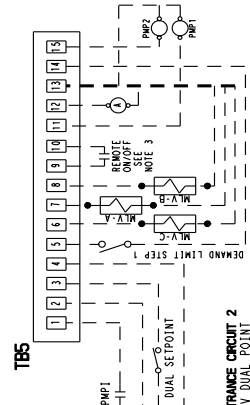
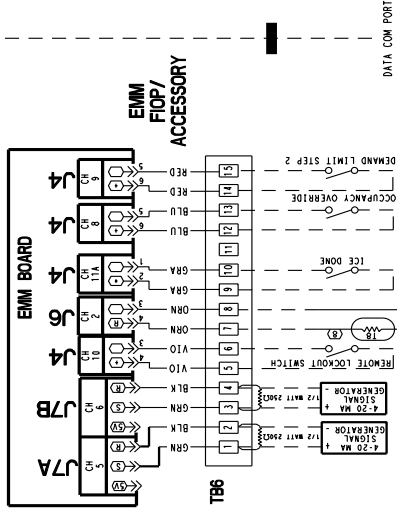
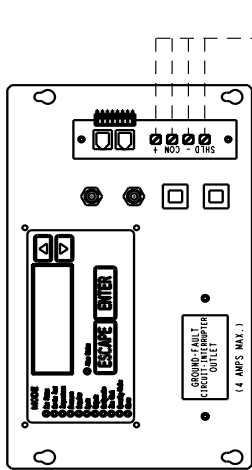
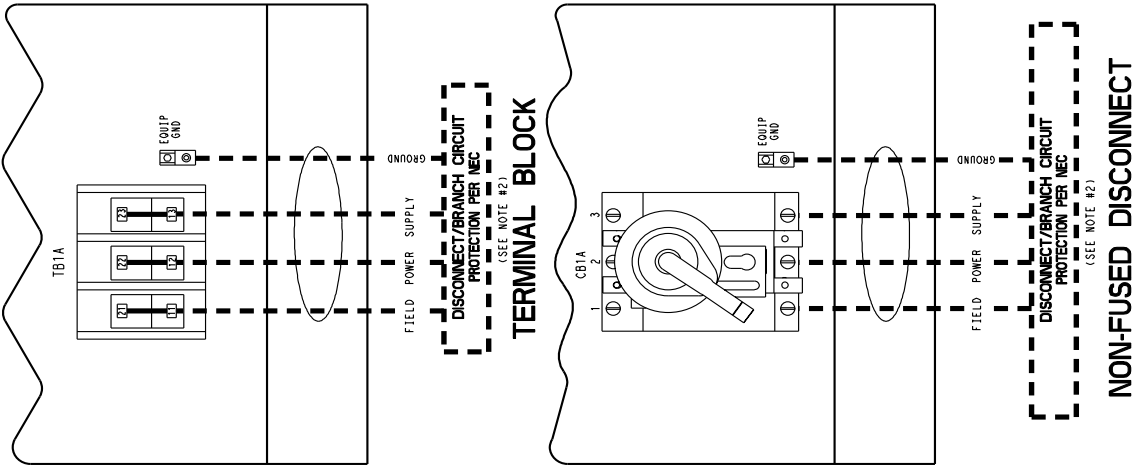

MAIN POWER ENTRANCE CIRCUIT 1
210-300 230V DUAL POINT

MAIN POWER ENTRANCE CIRCUIT 2
130-300 380/460/575V DUAL POINT

FIELD CONTROL WIRING ENTRY

DISPLAY LOCATION

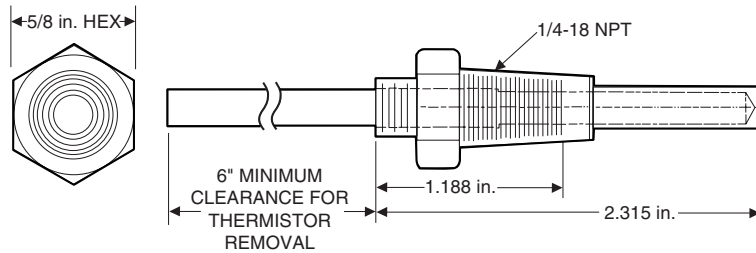

Fig. 47 — Dual Leaving Water Thermistor Well

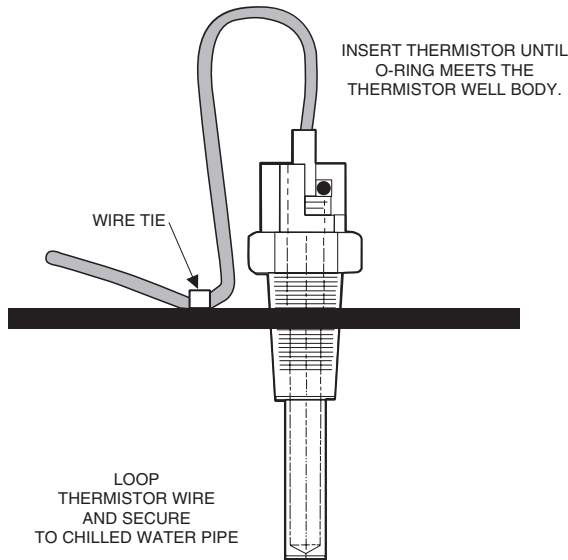

Fig. 48 — Dual Leaving Water Thermistor

CARRIER COMFORT NETWORK COMMUNICATION BUS WIRING — The communication bus wiring is a shielded, 3 conductor cable with drain wire and is field supplied and installed in the field.

The system elements are connected to the communication bus in a daisy chain arrangement. The positive pin of each system element communication connector must be wired to the positive pins of the system elements on either side of it. This is also required for the negative and signal ground pins of each system element. Wiring connections for CCN should be made at TB (terminal block) 3. Consult the CCN Contractor's Manual for further information. See Fig. 49.

NOTE: Conductors and drain wire must be 20 AWG (American Wire Gage) minimum stranded, tinned copper. Individual conductors must be insulated with PVC, PVC/nylon, vinyl, Teflon, or polyethylene. An aluminum/polyester 100% foil shield and an outer jacket of PVC, PVC/nylon, chrome vinyl, or Teflon with a minimum operating temperature range of -4 F (-20 C) to 140 F (60 C) is required. Refer to Table 13 for a list of manufacturers that produce CCN Bus Wiring that meets these requirements.

Table 13 — CCN Communication Bus Wiring

MANUFACTURER	PART NUMBER	
	Regular Wiring	Plenum Wiring
Alpha	1895	—
American	A21451	A48301
Belden	8205	884421
Columbia	D6451	—
Manhattan	M13402	M64430
Quabik	6130	—

It is important when connecting to a CCN communication bus that a color coding scheme be used for the entire network to simplify the installation. It is recommended that red be used for the signal positive, black for the signal negative, and white for the signal ground. Use a similar scheme for cables containing different colored wires. At each system element, the shields of its communication bus cables must be tied together. If the communication bus is entirely within one building, the resulting continuous shield must be connected to a ground at one point only. If the communication bus cable exits from one building and enters another, the shields must be connected to grounds at the lightning suppressor in each building where the cable enters or exits the building (one point per building only).

To connect the unit to the network:

1. Turn off power to the control box.
2. Cut the CCN wire and strip the ends of the red (+), white (ground), and black (-) conductors. Substitute appropriate colors for different colored cables.
3. Connect the red wire to (+) terminal on TB3 of the plug, the white wire to COM terminal, and the black wire to the (-) terminal.
4. The RJ14 CCN connector on TB3 can also be used, but is only intended for temporary connection (for example, a laptop computer running Service Tool).

IMPORTANT: A shorted CCN bus cable will prevent some routines from running and may prevent the unit from starting. If abnormal conditions occur, disconnect the machine from the CCN Network. If conditions return to normal, check the CCN connector and cable. Run new cable if necessary. A short in one section of the bus can cause problems with all system elements on the bus.

NON-CCN COMMUNICATION WIRING — The 30RB units offer several non-CCN translators. Refer to the separate installation instructions for additional wiring steps.

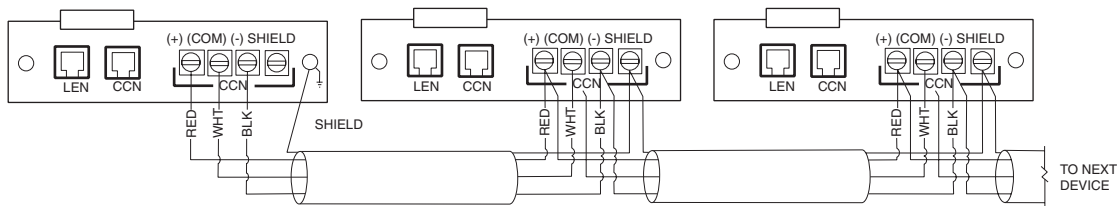

LEGEND

- CCN** — Carrier Comfort Network
- LEN** — Local Equipment Network

Fig. 49 — TB-3 — CCN Wiring

Step 6 — Install Accessories — A number of accessories are available to provide the following optional features (for details, refer to the Controls and Troubleshooting guide).

Energy Management Module is used for any of the following types of temperature reset, demand limit and ice features:

- 4 to 20 mA inputs for cooling set point reset and capacity limit (requires field-supplied 4 to 20 mA generator)
- 0 to 10 v output for percentage total capacity running
- 24 v discrete outputs for shutdown and running relays
- 10k space temperature input
- Discrete inputs for occupancy override, demand limit switch 2 (step 1 demand limit is wired to the base board, requires field-supplied dry contacts), remote lockout switch and ice done switch (requires field-supplied dry contacts)

NAVIGATOR™ DISPLAY — Provides hand-held, mobile capability using easy to read 4-line display. Keypad function is the same as the Scrolling Marquee Display. The Navigator features a mounting magnet for ‘hands free’ service of components.

REMOTE ENHANCED DISPLAY — For applications where remote monitoring of the equipment is required; the Remote Enhanced Display provides an indoor display, capable of monitoring any equipment on the Carrier Comfort Network (CCN) bus. A CCN bus is needed.

LOW AMBIENT OPERATION — If outdoor ambient operating temperatures below 32 F (0° C) are expected, refer to separate installation instructions for low-ambient operation using accessory Motormaster® control.

MINIMUM LOAD ACCESSORY — If minimum load accessory is required, contact your local Carrier representative for more details. For installation details, refer to separate installation instructions supplied with the accessory package.

UNIT SECURITY/PROTECTION ACCESSORIES — For applications with unique security and/or protection requirements, several options are available for unit protection. Compressor enclosures, security grilles and hail guards are available. Contact your local Carrier representative for more details. For installation details, refer to separate installation instructions supplied with the accessory package.

COMMUNICATION ACCESSORIES — A number of communication options are available to meet any requirement. Contact your local Carrier representative for more details. For installation details, refer to separate installation instructions supplied with the accessory package.

SERVICE OPTIONS — Two additional accessories are offered to aid in servicing 30RB units. A ground fault convenience outlet (GFI-CO), a remote service port, is a weather-proof enclosure with a communication port to plug-in the Navigator

device, are available. Contact your local Carrier representative for more details. For installation details, refer to separate installation instructions supplied with the accessory package.

Step 7 — Refrigerant Circuit

LEAK TESTING — Units are shipped with complete operating charge of R-410A (see Tables 2A-3B) and should be under sufficient pressure to conduct a leak test.

⚠ CAUTION

This system uses R-410A, which has higher pressures than R-22 and other refrigerants. No other refrigerant may be used in this system. Gage set, hoses, and recovery systems must be designed to handle R-410A refrigerant. If unsure about equipment, consult the equipment manufacturer.

Perform a leak test to ensure that leaks have not developed during unit shipment. Dehydration of the system is not required unless the entire refrigerant charge has been lost. Compressor oil equalization line fittings use Roto-lok fittings. If a leak is detected at these fittings, tighten fitting 49.0 ft-lb. If leak persists, open system and inspect the gasket surface for foreign material or damage. Do not reuse gaskets. Repair any leak found using good refrigeration practice.

DEHYDRATION — Refer to Carrier Standard Service Techniques Manual, Chapter 1, Refrigerants, Sections 6 and 7 for details. Do not use compressor to evacuate system.

REFRIGERANT CHARGE (Refer to Tables 2A-3B) — Immediately ahead of filter drier in each circuit is a factory-installed liquid line service valve. Each valve has a 1/4-in. Schrader connection for charging liquid refrigerant.

⚠ CAUTION

When charging, circulate water through the cooler at all times to prevent freezing. Freezing damage is considered abuse and may void the Carrier warranty.

⚠ CAUTION

DO NOT OVERCHARGE system. Overcharging results in higher discharge pressure possible compressor damage, and higher power consumption.

⚠ CAUTION

Refrigerant charge must be removed slowly to prevent loss of compressor oil that could result in compressor failure.