

SECTION 22 00 00

PLUMBING, GENERAL PURPOSE  
02/09

PART 1 GENERAL

1.1 REFERENCES

The publications listed below form a part of this specification to the extent referenced. The publications are referred to within the text by the basic designation only.

AIR-CONDITIONING, HEATING AND REFRIGERATION INSTITUTE (AHRI)

AHRI 1010 (2002) Self-Contained, Mechanically Refrigerated Drinking-Water Coolers

AMERICAN SOCIETY OF HEATING, REFRIGERATING AND AIR-CONDITIONING ENGINEERS (ASHRAE)

ASHRAE 90.1 - IP (2007) Energy Standard for Buildings Except Low-Rise Residential Buildings, I-P Edition

ASHRAE 90.1 - SI (2004; Addendas a through p, r through v, x,ak 2006; Supp to Addendas 2006; Errata 2007; Interpretations 8 - 15:2007; Errata 2008; INT 16-21 2008; Errata 2008; INT 22-26 2008) Energy Standard for Buildings Except Low-Rise Residential Buildings, SI Edition

AMERICAN SOCIETY OF SANITARY ENGINEERING (ASSE)

ASSE 1001 (2008) Atmospheric Type Vacuum Breakers

ASSE 1003 (2001; Errata, 2003) Performance Requirements for Water Pressure Reducing Valves

ASSE 1005 (1999) Water Heater Drain Valves 3/4 Inch Size

ASSE 1010 (2004) Water Hammer Arresters

ASSE 1011 (2004; Errata 2004) Hose Connection Vacuum Breakers

ASSE 1012 (2002) Backflow Preventer with Intermediate Atmospheric Vent

ASSE 1013 (2005) Reduced Pressure Principle Backflow Preventers and Reduced Pressure Fire Protection Principle Backflow Preventers

ASSE 1018 (2001) Trap Seal Primer Valves - Potable, Water Supplied

ASSE 1019 (2004; Errata 2005) Vacuum Breaker Wall Hydrants, Freeze Resistant, Automatic Draining Type

ASSE 1020 (2004; Errata 2004; Errata 2004) Pressure Vacuum Breaker Assembly

ASSE 1037 (1990) Performance Requirements for Pressurized Flushing Devices (Flushometer) for Plumbing Fixtures

AMERICAN WATER WORKS ASSOCIATION (AWWA)

AWWA 10084 (2005) Standard Methods for the Examination of Water and Wastewater

AWWA B300 (2004) Hypochlorites

AWWA B301 (2004) Liquid Chlorine

AWWA C203 (2002) Coal-Tar Protective Coatings and Linings for Steel Water Pipelines - Enamel and Tape - Hot-Applied

AWWA C606 (2006) Grooved and Shouldered Joints

AWWA C651 (2005; Errata 2005) Standard for Disinfecting Water Mains

AWWA C652 (2002) Disinfection of Water-Storage Facilities

AWWA C700 (2002; Errata 2008) Standard for Cold Water Meters - Displacement Type, Bronze Main Case

AWWA C701 (2007) Standard for Cold-Water Meters - Turbine Type for Customer Service

AWWA D100 (2007) Welded Steel Tanks for Water Storage

AMERICAN WELDING SOCIETY (AWS)

AWS A5.8/A5.8M (2004; Errata 2004) Specification for Filler Metals for Brazing and Braze Welding

AWS B2.2 (1991) Brazing Procedure and Performance Qualification

ASME INTERNATIONAL (ASME)

ASME A112.1.2 (2004) Standard for Air Gaps in Plumbing Systems (For Plumbing Fixtures and Water-Connected Receptors)

ASME A112.14.1 (2003; R 2008) Backwater Valves

ASME A112.19.1 (2008) Enameled Cast Iron Plumbing Fixtures

ASME A112.19.2 (2008) Standard for Vitreous China Plumbing Fixtures and Hydraulic Requirements for Water Closets and Urinals

ASME A112.19.4M (1994; Errata 1996; Supplement 1998; Supplement 2000; R 2004) Porcelain Enameled Formed Steel Plumbing Fixtures

ASME A112.19.5 (2005) Trim for Water-Closet Bowls, Tanks and Urinals

ASME A112.21.2M (1983) Roof Drains

ASME A112.36.2M (1991; R 2008) Cleanouts

ASME A112.6.1M (1997; R 2008) Floor Affixed Supports for Off-the-Floor Plumbing Fixtures for Public Use

ASME A112.6.3 (2001; R 2007) Standard for Floor and Trench Drains

ASME B1.20.1 (1983; R 2006) Pipe Threads, General Purpose (Inch)

ASME B16.12 (1998; R 2006) Cast Iron Threaded Drainage Fittings

ASME B16.15 (2006) Cast Bronze Threaded Fittings Classes 125 and 250

ASME B16.18 (2001; R 2005) Cast Copper Alloy Solder Joint Pressure Fittings

ASME B16.21 (2005) Nonmetallic Flat Gaskets for Pipe Flanges

ASME B16.22 (2001; R 2005) Standard for Wrought Copper and Copper Alloy Solder Joint Pressure Fittings

ASME B16.23 (2002; Errata 2003; R 2006) Cast Copper Alloy Solder Joint Drainage Fittings - DWV

ASME B16.24 (2006) Cast Copper Alloy Pipe Flanges and Flanged Fittings: Classes 150, 300, 400, 600, 900, 1500, and 2500

ASME B16.29 (2007) Wrought Copper and Wrought Copper Alloy Solder Joint Drainage Fittings - DWV

ASME B16.3 (2006) Malleable Iron Threaded Fittings, Classes 150 and 300

ASME B16.34	(2004) Valves - Flanged, Threaded and Welding End
ASME B16.39	(1998; R 2006) Standard for Malleable Iron Threaded Pipe Unions; Classes 150, 250, and 300
ASME B16.4	(2006) Standard for Gray Iron Threaded Fittings; Classes 125 and 250
ASME B16.5	(2003) Standard for Pipe Flanges and Flanged Fittings: NPS 1/2 Through NPS 24
ASME B31.1	(2007; Addenda 2008) Power Piping
ASME B31.5	(2006) Refrigeration Piping and Heat Transfer Components
ASME B40.100	(2005) Pressure Gauges and Gauge Attachments
ASME BPVC SEC IX	(2007; Addenda 2008) Boiler and Pressure Vessel Code; Section IX, Welding and Brazing Qualifications
ASME BPVC SEC VIII D1	(2007; Addenda 2008) Boiler and Pressure Vessel Code; Section VIII, Pressure Vessels Division 1 - Basic Coverage
ASME CSD-1	(2006) Control and Safety Devices for Automatically Fired Boilers

ASTM INTERNATIONAL (ASTM)

ASTM A 105/A 105M	(2005) Standard Specification for Carbon Steel Forgings for Piping Applications
ASTM A 183	(2003) Standard Specification for Carbon Steel Track Bolts and Nuts
ASTM A 193/A 193M	(2008b) Standard Specification for Alloy-Steel and Stainless Steel Bolting Materials for High-Temperature Service
ASTM A 47/A 47M	(1999; R 2004) Standard Specification for Steel Sheet, Aluminum-Coated, by the Hot-Dip Process
ASTM A 515/A 515M	(2003; R 2007) Standard Specification for Pressure Vessel Plates, Carbon Steel, for Intermediate- and Higher-Temperature Service
ASTM A 516/A 516M	(2006) Standard Specification for Pressure Vessel Plates, Carbon Steel, for Moderate- and Lower-Temperature Service

ASTM A 518/A 518M	(1999; R 2008) Standard Specification for Corrosion-Resistant High-Silicon Iron Castings
ASTM A 53/A 53M	(2007) Standard Specification for Pipe, Steel, Black and Hot-Dipped, Zinc-Coated, Welded and Seamless
ASTM A 536	(1984e1; R 2004) Standard Specification for Ductile Iron Castings
ASTM A 733	(2003) Standard Specification for Welded and Seamless Carbon Steel and Austenitic Stainless Steel Pipe Nipples
ASTM A 74	(2008a) Standard Specification for Cast Iron Soil Pipe and Fittings
ASTM A 888	(2008) Standard Specification for Hubless Cast Iron Soil Pipe and Fittings for Sanitary and Storm Drain, Waste, and Vent Piping Applications
ASTM B 111/B 111M	(2008a) Standard Specification for Copper and Copper-Alloy Seamless Condenser Tubes and Ferrule Stock
ASTM B 117	(2007a) Standing Practice for Operating Salt Spray (Fog) Apparatus
ASTM B 152/B 152M	(2006ae1) Standard Specification for Copper Sheet, Strip, Plate, and Rolled Bar
ASTM B 306	(2002) Standard Specification for Copper Drainage Tube (DWV)
ASTM B 32	(2008) Standard Specification for Solder Metal
ASTM B 370	(2003) Standard Specification for Copper Sheet and Strip for Building Construction
ASTM B 42	(2002e1) Standard Specification for Seamless Copper Pipe, Standard Sizes
ASTM B 43	(1998; R 2004) Standard Specification for Seamless Red Brass Pipe, Standard Sizes
ASTM B 584	(2008a) Standard Specification for Copper Alloy Sand Castings for General Applications
ASTM B 75	(2002) Standard Specification for Seamless Copper Tube
ASTM B 75M	(1999; R 2005) Standard Specification for Seamless Copper Tube (Metric)

ASTM B 813 (2000e1) Standard Specification for Liquid and Paste Fluxes for Soldering of Copper and Copper Alloy Tube

ASTM B 828 (2002) Standard Practice for Making Capillary Joints by Soldering of Copper and Copper Alloy Tube and Fittings

ASTM B 88 (2003) Standard Specification for Seamless Copper Water Tube

ASTM B 88M (2005) Standard Specification for Seamless Copper Water Tube (Metric)

ASTM C 1053 (2000; R 2005) Standard Specification for Borosilicate Glass Pipe and Fittings for Drain, Waste, and Vent (DWV) Applications

ASTM C 564 (2008) Standard Specification for Rubber Gaskets for Cast Iron Soil Pipe and Fittings

ASTM C 920 (2008) Standard Specification for Elastomeric Joint Sealants

ASTM D 1004 (2008) Initial Tear Resistance of Plastic Film and Sheeting

ASTM D 1248 (2005) Standard Specification for Polyethylene Plastics Extrusion Materials for Wire and Cable

ASTM D 1785 (2006) Standard Specification for Poly(Vinyl Chloride) (PVC), Plastic Pipe, Schedules 40, 80, and 120

ASTM D 2000 (2008) Standard Classification System for Rubber Products in Automotive Applications

ASTM D 2235 (2004) Standard Specification for Solvent Cement for Acrylonitrile-Butadiene-Styrene (ABS) Plastic Pipe and Fittings

ASTM D 2239 (2003) Standard Specification for Polyethylene (PE) Plastic Pipe (SIDR-PR) Based on Controlled Inside Diameter

ASTM D 2241 (2005) Standard Specification for Poly(Vinyl Chloride) (PVC) Pressure-Rated Pipe (SDR Series)

ASTM D 2464 (2006) Standard Specification for Threaded Poly(Vinyl Chloride) (PVC) Plastic Pipe Fittings, Schedule 80

ASTM D 2466 (2006) Standard Specification for Poly(Vinyl Chloride) (PVC) Plastic Pipe

	Fittings, Schedule 40
ASTM D 2467	(2006) Standard Specification for Poly(Vinyl Chloride) (PVC) Plastic Pipe Fittings, Schedule 80
ASTM D 2485	(1991; R 2007) Evaluating Coatings for High Temperature Service
ASTM D 2564	(2004e1) Standard Specification for Solvent Cements for Poly(Vinyl Chloride) (PVC) Plastic Piping Systems
ASTM D 2657	(2007) Heat Fusion Joining Polyolefin Pipe and Fittings
ASTM D 2665	(2008b) Standard Specification for Poly(Vinyl Chloride) (PVC) Plastic Drain, Waste, and Vent Pipe and Fittings
ASTM D 2672	(1996a; R 2003) Joints for IPS PVC Pipe Using Solvent Cement
ASTM D 2683	(2004) Standard Specification for Socket-Type Polyethylene Fittings for Outside Diameter-Controlled Polyethylene Pipe and Tubing
ASTM D 2822	(2005) Asphalt Roof Cement
ASTM D 2846/D 2846M	(2006) Chlorinated Poly(Vinyl Chloride) (CPVC) Plastic Hot- and Cold-Water Distribution Systems
ASTM D 2855	(1996; R 2002) Standard Practice for Making Solvent-Cemented Joints with Poly(Vinyl Chloride) (PVC) Pipe and Fittings
ASTM D 2996	(2001; R 2007e1) Filament-Wound "Fiberglass" (Glass-Fiber-Reinforced Thermosetting-Resin) Pipe
ASTM D 3122	(1995; R 2002) Solvent Cements for Styrene-Rubber (SR) Plastic Pipe and Fittings
ASTM D 3138	(2004) Solvent Cements for Transition Joints Between Acrylonitrile-Butadiene-Styrene (ABS) and Poly(Vinyl Chloride) (PVC) Non-Pressure Piping Components
ASTM D 3139	(1998; R 2005) Joints for Plastic Pressure Pipes Using Flexible Elastomeric Seals
ASTM D 3212	(2007) Standard Specification for Joints

for Drain and Sewer Plastic Pipes Using Flexible Elastomeric Seals

ASTM D 3261	(2003) Standard Specification for Butt Heat Fusion Polyethylene (PE) Plastic Fittings for Polyethylene (PE) Plastic Pipe and Tubing
ASTM D 3311	(2008) Drain, Waste, and Vent (DWV) Plastic Fittings Patterns
ASTM D 4060	(2007) Abrasion Resistance of Organic Coatings by the Taber Abraser
ASTM D 4101	(2008) Standard Specification for Polypropylene Injection and Extrusion Materials
ASTM D 4551	(1996e1; R 2008) Poly(Vinyl Chloride) (PVC) Plastic Flexible Concealed Water-Containment Membrane
ASTM D 638	(2008) Standard Test Method for Tensile Properties of Plastics
ASTM E 1	(2007) Standard Specification for ASTM Liquid-in-Glass Thermometers
ASTM E 2129	(2005) Standard Practice for Data Collection for Sustainability Assessment of Building Products
ASTM E 96/E 96M	(2005) Standard Test Methods for Water Vapor Transmission of Materials
ASTM F 1290	(1998a; R 2004) Electrofusion Joining Polyolefin Pipe and Fittings
ASTM F 1760	(2001; R 2005e1) Coextruded Poly(Vinyl Chloride) (PVC) Non-Pressure Plastic Pipe Having Reprocessed-Recycled Content
ASTM F 409	(2002) Thermoplastic Accessible and Replaceable Plastic Tube and Tubular Fittings
ASTM F 437	(2006) Standard Specification for Threaded Chlorinated Poly(Vinyl Chloride) (CPVC) Plastic Pipe Fittings, Schedule 80
ASTM F 438	(2004) Standard Specification for Socket-Type Chlorinated Poly(Vinyl Chloride) (CPVC) Plastic Pipe Fittings, Schedule 40
ASTM F 439	(2006) Standard Specification for Chlorinated Poly(Vinyl Chloride) (CPVC)

Plastic Pipe Fittings, Schedule 80

- ASTM F 441/F 441M (2002) Standard Specification for Chlorinated Poly(Vinyl Chloride) (CPVC) Plastic Pipe, Schedules 40 and 80
- ASTM F 442/F 442M (1999; R 2005e1) Standard Specification for Chlorinated Poly(Vinyl Chloride) (CPVC) Plastic Pipe (SDR-PR)
- ASTM F 477 (2008) Standard Specification for Elastomeric Seals (Gaskets) for Joining Plastic Pipe
- ASTM F 493 (2004) Solvent Cements for Chlorinated Poly(Vinyl Chloride) (CPVC) Plastic Pipe and Fittings
- ASTM F 628 (2008) Acrylonitrile-Butadiene-Styrene (ABS) Schedule 40 Plastic Drain, Waste, and Vent Pipe with a Cellular Core
- ASTM F 877 (2007) Crosslinked Polyethylene (PEX) Plastic Hot- and Cold- Water Distribution Systems
- ASTM F 891 (2007) Coextruded Poly (Vinyl Chloride) (PVC) Plastic Pipe with a Cellular Core

CAST IRON SOIL PIPE INSTITUTE (CISPI)

- CISPI 301 (2004) Hubless Cast Iron Soil Pipe and Fittings for Sanitary and Storm Drain, Waste, and Vent Piping Applications
- CISPI 310 (2004) Coupling for Use in Connection with Hubless Cast Iron Soil Pipe and Fittings for Sanitary and Storm Drain, Waste, and Vent Piping Applications

COPPER DEVELOPMENT ASSOCIATION (CDA)

- CDA A4015 (1994; R 1995) Copper Tube Handbook

CSA AMERICA, INC. (CSA/AM)

- CSA/AM Z21.22 (1999; Addenda A 2000, Addenda B 2001; R 2004) Relief Valves for Hot Water Supply Systems

FOUNDATION FOR CROSS-CONNECTION CONTROL AND HYDRAULIC RESEARCH (FCCCHR)

- FCCCHR Manual (1988e9) Manual of Cross-Connection Control

INTERNATIONAL ASSOCIATION OF PLUMBING AND MECHANICAL OFFICIALS (IAPMO)

IAPMO PS 117	(2005) Press Type Or Plain End Rub Gsktd W/ Nail CU & CU Alloy Fittings for Install On CU Tubing
IAPMO Z124.1.2	(2005) Plastic Bathtub and Shower Units
IAPMO Z124.8	(1990) Plastic Bathtub Liners
UPC	(2003) Uniform Plumbing Code

INTERNATIONAL CODE COUNCIL (ICC)

ICC A117.1	(2003; R 2004) Standard for Accessible and Usable Buildings and Facilities
ICC IPC	(2006; Supplement 2007) International Plumbing Code

INTERNATIONAL SAFETY EQUIPMENT ASSOCIATION (ISEA)

ISEA Z358.1	(2004) Emergency Eyewash and Shower Equipment
-------------	--

MANUFACTURERS STANDARDIZATION SOCIETY OF THE VALVE AND FITTINGS  
INDUSTRY (MSS)

MSS SP-110	(1996) Ball Valves Threaded, Socket-Welding, Solder Joint, Grooved and Flared Ends
MSS SP-25	(2008) Standard Marking System for Valves, Fittings, Flanges and Unions
MSS SP-44	(2006) Steel Pipeline Flanges
MSS SP-58	(2002) Standard for Pipe Hangers and Supports - Materials, Design and Manufacture
MSS SP-67	(2002a; R 2004) Standard for Butterfly Valves
MSS SP-69	(2003; R 2004) Standard for Pipe Hangers and Supports - Selection and Application
MSS SP-70	(2006) Standard for Cast Iron Gate Valves, Flanged and Threaded Ends
MSS SP-71	(2005) Standard for Gray Iron Swing Check Valves, Flanged and Threaded Ends
MSS SP-72	(1999) Standard for Ball Valves with Flanged or Butt-Welding Ends for General Service
MSS SP-73	(2003) Brazing Joints for Copper and Copper Alloy Pressure Fittings

MSS SP-78 (2005a) Cast Iron Plug Valves, Flanged and Threaded Ends

MSS SP-80 (2008) Bronze Gate, Globe, Angle and Check Valves

MSS SP-83 (2006) Standard for Class 3000 Steel Pipe Unions Socket Welding and Threaded

MSS SP-85 (2002) Standard for Cast Iron Globe & Angle Valves, Flanged and Threaded Ends

NATIONAL ELECTRICAL MANUFACTURERS ASSOCIATION (NEMA)

NEMA 250 (2003) Enclosures for Electrical Equipment (1000 Volts Maximum)

NEMA MG 1 (2007; Errata 2008) Standard for Motors and Generators

NATIONAL FIRE PROTECTION ASSOCIATION (NFPA)

NFPA 90A (2008) Standard for the Installation of Air Conditioning and Ventilating Systems

NSF INTERNATIONAL (NSF)

NSF 14 (2008) Plastics Piping System Components and Related Materials

NSF 61 (2008) Drinking Water System Components - Health Effects

PLASTIC PIPE AND FITTINGS ASSOCIATION (PPFA)

PPFA-01 (1998) Plastic Pipe in Fire Resistive Construction

PLUMBING AND DRAINAGE INSTITUTE (PDI)

PDI G 101 (1996) Testing and Rating Procedure for Grease Interceptors with Appendix of Sizing and Installation Data

PDI WH 201 (2006) Water Hammer Arresters Standard

SOCIETY OF AUTOMOTIVE ENGINEERS INTERNATIONAL (SAE)

SAE J1508 (1997) Hose Clamp Specifications

THE SOCIETY FOR PROTECTIVE COATINGS (SSPC)

SSPC SP 5 (2007) White Metal Blast Cleaning

U.S. ENVIRONMENTAL PROTECTION AGENCY (EPA)

Energy Star	(1992; R 2006) Energy Star Energy Efficiency Labeling System
PL 93-523	(1974; A 1999) Safe Drinking Water Act
U.S. GREEN BUILDING COUNCIL (USGBC)	
LEED	(2002; R 2005) Leadership in Energy and Environmental Design(tm) Green Building Rating System for New Construction (LEED-NC)
U.S. NATIONAL ARCHIVES AND RECORDS ADMINISTRATION (NARA)	
10 CFR 430	Energy Conservation Program for Consumer Products
21 CFR 175	Indirect Food Additives: Adhesives and Components of Coatings
40 CFR 50.12	National Primary and Secondary Ambient Air Quality Standards for Lead
PL 109-58	Energy Policy Act of 2005 (EPAct05)
UNDERWRITERS LABORATORIES (UL)	
UL 174	(2004; Rev thru Sep 2008) Household Electric Storage Tank Water Heaters
UL 1951	(1994; Rev thru Oct 2008) Standard for Electric Plumbing Accessories
UL 430	(2004; Rev thru Nov 2007) Waste Disposers
UL 499	(2005; Rev thru Aug 2008) Electric Heating Appliances
UL 732	(1995; Rev thru Feb 2005) Oil-Fired Storage Tank Water Heaters

## 1.2 SUBMITTALS

Government approval is required for submittals with a "G" designation; submittals not having a "G" designation are for information only or as otherwise designated. When used, a designation following the "G" designation identifies the office that will review the submittal for the Government. The following shall be submitted in accordance with Section 01 33 00 SUBMITTAL PROCEDURES:

### SD-03 Product Data

Fixtures; (LEED)

List of installed fixtures with manufacturer, model, and flow rate.

Flush valve water closets

Flush valve urinals

Wall hung lavatories

Kitchen sinks

Service sinks

Drinking-water coolers

Water heaters

Pumps

Backflow prevention assemblies; G

Shower Faucets

Welding

A copy of qualified procedures and a list of names and identification symbols of qualified welders and welding operators.

Plumbing System

Diagrams, instructions, and other sheets proposed for posting.

#### SD-06 Test Reports

Tests, Flushing and Disinfection

Test reports in booklet form showing all field tests performed to adjust each component and all field tests performed to prove compliance with the specified performance criteria, completion and testing of the installed system. Each test report shall indicate the final position of controls.

Test of Backflow Prevention Assemblies; G.

Certification of proper operation shall be as accomplished in accordance with state regulations by an individual certified by the state to perform such tests. If no state requirement exists, the Contractor shall have the manufacturer's representative test the device, to ensure the unit is properly installed and performing as intended. The Contractor shall provide written documentation of the tests performed and signed by the individual performing the tests.

#### SD-07 Certificates

Materials and Equipment

Where equipment is specified to conform to requirements of the ASME Boiler and Pressure Vessel Code, the design, fabrication, and installation shall conform to the code.

## SD-10 Operation and Maintenance Data

### Plumbing System; G

Submit in accordance with Section 01 78 23 OPERATION AND MAINTENANCE DATA.

#### 1.3 STANDARD PRODUCTS

Specified materials and equipment shall be standard products of a manufacturer regularly engaged in the manufacture of such products. Specified equipment shall essentially duplicate equipment that has performed satisfactorily at least two years prior to bid opening. Standard products shall have been in satisfactory commercial or industrial use for 2 years prior to bid opening. The 2-year use shall include applications of equipment and materials under similar circumstances and of similar size. The product shall have been for sale on the commercial market through advertisements, manufacturers' catalogs, or brochures during the 2 year period.

##### 1.3.1 Alternative Qualifications

Products having less than a two-year field service record will be acceptable if a certified record of satisfactory field operation for not less than 6000 hours, exclusive of the manufacturer's factory or laboratory tests, can be shown.

##### 1.3.2 Service Support

The equipment items shall be supported by service organizations. Submit a certified list of qualified permanent service organizations for support of the equipment which includes their addresses and qualifications. These service organizations shall be reasonably convenient to the equipment installation and able to render satisfactory service to the equipment on a regular and emergency basis during the warranty period of the contract.

##### 1.3.3 Manufacturer's Nameplate

Each item of equipment shall have a nameplate bearing the manufacturer's name, address, model number, and serial number securely affixed in a conspicuous place; the nameplate of the distributing agent will not be acceptable.

##### 1.3.4 Modification of References

In each of the publications referred to herein, consider the advisory provisions to be mandatory, as though the word, "shall" had been substituted for "should" wherever it appears. Interpret references in these publications to the "authority having jurisdiction", or words of similar meaning, to mean the Contracting Officer.

###### 1.3.4.1 Definitions

For the International Code Council (ICC) Codes referenced in the contract documents, advisory provisions shall be considered mandatory, the word "should" shall be interpreted as "shall." Reference to the "code official" shall be interpreted to mean the "Contracting Officer." For Navy owned

property, references to the "owner" shall be interpreted to mean the "Contracting Officer." For leased facilities, references to the "owner" shall be interpreted to mean the "lessor." References to the "permit holder" shall be interpreted to mean the "Contractor."

#### 1.3.4.2 Administrative Interpretations

For ICC Codes referenced in the contract documents, the provisions of Chapter 1, "Administrator," do not apply. These administrative requirements are covered by the applicable Federal Acquisition Regulations (FAR) included in this contract and by the authority granted to the Officer in Charge of Construction to administer the construction of this project. References in the ICC Codes to sections of Chapter 1, shall be applied appropriately by the Contracting Officer as authorized by his administrative cognizance and the FAR.

#### 1.4 DELIVERY, STORAGE, AND HANDLING

Handle, store, and protect equipment and materials to prevent damage before and during installation in accordance with the manufacturer's recommendations, and as approved by the Contracting Officer. Replace damaged or defective items.

#### 1.5 PERFORMANCE REQUIREMENTS

##### 1.5.1 Welding

[Piping shall be welded in accordance with qualified procedures using performance-qualified welders and welding operators. Procedures and welders shall be qualified in accordance with ASME BPVC SEC IX. Welding procedures qualified by others, and welders and welding operators qualified by another employer, may be accepted as permitted by ASME B31.1. The Contracting Officer shall be notified 24 hours in advance of tests, and the tests shall be performed at the work site if practicable. Welders or welding operators shall apply their assigned symbols near each weld they make as a permanent record. Structural members shall be welded in accordance with Section 05 05 23 WELDING, STRUCTURAL.

#### 1.6 REGULATORY REQUIREMENTS

Unless otherwise required herein, plumbing work shall be in accordance with ICC IPC. Energy consuming products and systems shall be in accordance with PL 109-58 and ASHRAE 90.1 - IP

#### 1.7 PROJECT/SITE CONDITIONS

The Contractor shall become familiar with details of the work, verify dimensions in the field, and advise the Contracting Officer of any discrepancy before performing any work.

#### 1.8 INSTRUCTION TO GOVERNMENT PERSONNEL

When specified in other sections, furnish the services of competent instructors to give full instruction to the designated Government personnel in the adjustment, operation, and maintenance, including pertinent safety requirements, of the specified equipment or system. Instructors shall be thoroughly familiar with all parts of the installation and shall be trained

in operating theory as well as practical operation and maintenance work.

Instruction shall be given during the first regular work week after the equipment or system has been accepted and turned over to the Government for regular operation. The number of man-days (8 hours per day) of instruction furnished shall be as specified in the individual section. When more than 4 man-days of instruction are specified, use approximately half of the time for classroom instruction. Use other time for instruction with the equipment or system.

When significant changes or modifications in the equipment or system are made under the terms of the contract, provide additional instruction to acquaint the operating personnel with the changes or modifications.

#### 1.9 ACCESSIBILITY OF EQUIPMENT

Install all work so that parts requiring periodic inspection, operation, maintenance, and repair are readily accessible. Install concealed valves, expansion joints, controls, dampers, and equipment requiring access, in locations freely accessible through access doors.

### PART 2 PRODUCTS

#### 2.1 MATERIALS

Materials for various services shall be in accordance with TABLES I and II. Pipe schedules shall be selected based on service requirements. Pipe fittings shall be compatible with the applicable pipe materials. Plastic pipe, fittings, and solvent cement shall meet NSF 14 and shall be NSF listed for the service intended. Plastic pipe, fittings, and solvent cement used for potable hot and cold water service shall bear the NSF seal "NSF-PW." Polypropylene pipe and fittings shall conform to dimensional requirements of Schedule 40, Iron Pipe size. Pipe threads (except dry seal) shall conform to ASME B1.20.1. Grooved pipe couplings and fittings shall be from the same manufacturer. Material or equipment containing lead shall not be used in any potable water system. In line devices such as water meters, building valves, check valves, meter stops, valves, fittings and back flow preventers shall comply with PL 93-523 and NSF 61, Section 8. End point devices such as drinking water fountains, lavatory faucets, kitchen and bar faucets, residential ice makers, supply stops and end point control valves used to dispense water for drinking must meet the requirements of NSF 61, Section 9. Hubless cast-iron soil pipe shall not be installed underground, under concrete floor slabs, or in crawl spaces below kitchen floors. Plastic pipe shall not be installed in air plenums. Plastic pipe shall not be installed in a pressure piping system in buildings greater than three stories including any basement levels.

##### 2.1.1 Pipe Joint Materials

Grooved pipe and hubless cast-iron soil pipe shall not be used underground. Solder containing lead shall not be used with copper pipe. Cast iron soil pipe and fittings shall be marked with the collective trademark of the Cast Iron Soil Institute. Joints and gasket materials shall conform to the following:

- a. Coupling for Cast-Iron Pipe: for hub and spigot type ASTM A 74, AWWA C606. For hubless type: CISPI 310

- b. Coupling for Steel Pipe: AWWA C606.
- c. Couplings for Grooved Pipe: [Ductile Iron ASTM A 536 (Grade 65-45-12)] [Malleable Iron ASTM A 47/A 47M, Grade 32510]. [Copper ASTM A 536].
- d. Flange Gaskets: Gaskets shall be made of non-asbestos material in accordance with ASME B16.21. Gaskets shall be flat, 1/16 inch thick, and contain Aramid fibers bonded with Styrene Butadiene Rubber (SBR) or Nitro Butadiene Rubber (NBR). Gaskets shall be the full face or self centering flat ring type. Gaskets used for hydrocarbon service shall be bonded with NBR.
- e. Brazing Material: Brazing material shall conform to AWS A5.8/A5.8M, BCuP-5.
- f. Brazing Flux: Flux shall be in paste or liquid form appropriate for use with brazing material. Flux shall be as follows: lead-free; have a 100 percent flushable residue; contain slightly acidic reagents; contain potassium borides; and contain fluorides.
- g. Solder Material: Solder metal shall conform to ASTM B 32.
- h. Solder Flux: Flux shall be liquid form, non-corrosive, and conform to ASTM B 813, Standard Test 1.
- i. PTFE Tape: PTFE Tape, for use with Threaded Metal or Plastic Pipe.
- j. Rubber Gaskets for Cast-Iron Soil-Pipe and Fittings (hub and spigot type and hubless type): ASTM C 564.
- k. Rubber Gaskets for Grooved Pipe: ASTM D 2000, maximum temperature 230 degrees F.
- l. Flexible Elastomeric Seals: ASTM D 3139, ASTM D 3212 or ASTM F 477.
- m. Bolts and Nuts for Grooved Pipe Couplings: Heat-treated carbon steel, ASTM A 183.
- n. Solvent Cement for Transition Joints between ABS and PVC Nonpressure Piping Components: ASTM D 3138.
- o. Plastic Solvent Cement for ABS Plastic Pipe: ASTM D 2235.
- p. Plastic Solvent Cement for PVC Plastic Pipe: ASTM D 2564 and ASTM D 2855.
- q. Plastic Solvent Cement for CPVC Plastic Pipe: ASTM F 493.
- r. Flanged fittings including flanges, bolts, nuts, bolt patterns, etc., shall be in accordance with ASME B16.5 class 150 and shall have the manufacturer's trademark affixed in accordance with MSS SP-25. Flange material shall conform to ASTM A 105/A 105M. Blind flange material shall conform to ASTM A 516/A 516M cold service and ASTM A 515/A 515M for hot service. Bolts shall be high strength or intermediate strength with material conforming to ASTM A 193/A 193M.

- s. Plastic Solvent Cement for Styrene Rubber Plastic Pipe: ASTM D 3122.
- t. Press fittings for Copper Pipe and Tube: Copper press fittings shall conform to the material and sizing requirements of ASME B16.18 or ASME B16.22 and performance criteria of IAPMO PS 117. Sealing elements for copper press fittings shall be EPDM, FKM or HNBR. Sealing elements shall be factory installed or an alternative supplied fitting manufacturer. Sealing element shall be selected based on manufacturer's approved application guidelines.
- u. Copper tubing shall conform to ASTM B 88, Type K, L or M.

#### 2.1.2 Miscellaneous Materials

Miscellaneous materials shall conform to the following:

- a. Water Hammer Arrester: PDI WH 201. [Water hammer arrester shall be [diaphragm][ or ][piston] type.]
- b. Copper, Sheet and Strip for Building Construction: ASTM B 370.
- c. Asphalt Roof Cement: ASTM D 2822.
- d. Hose Clamps: SAE J1508.
- e. Supports for Off-The-Floor Plumbing Fixtures: ASME A112.6.1M.
- f. Metallic Cleanouts: ASME A112.36.2M.
- g. Plumbing Fixture Setting Compound: A preformed flexible ring seal molded from hydrocarbon wax material. The seal material shall be nonvolatile nonasphaltic and contain germicide and provide watertight, gastight, odorproof and verminproof properties.
- h. Coal-Tar Protective Coatings and Linings for Steel Water Pipelines: AWWA C203.
- i. Hypochlorites: AWWA B300.
- j. Liquid Chlorine: AWWA B301.
- k. Gauges - Pressure and Vacuum Indicating Dial Type - Elastic Element: ASME B40.100.
- l. Thermometers: ASTM E 1. Mercury shall not be used in thermometers.

#### 2.1.3 Pipe Insulation Material

Insulation shall be as specified in Section 23 07 00 THERMAL INSULATION FOR MECHANICAL SYSTEMS.

#### 2.2 PIPE HANGERS, INSERTS, AND SUPPORTS

Pipe hangers, inserts, and supports shall conform to MSS SP-58 and MSS SP-69.

## 2.3 VALVES

Valves shall be provided on supplies to equipment and fixtures. Valves 2-1/2 inches and smaller shall be bronze with threaded bodies for pipe and solder-type connections for tubing. Valves 3 inches and larger shall have flanged iron bodies and bronze trim. Pressure ratings shall be based upon the application. Grooved end valves may be provided if the manufacturer certifies that the valves meet the performance requirements of applicable MSS standard. Valves shall conform to the following standards:

Description	Standard
Butterfly Valves	MSS SP-67
Cast-Iron Gate Valves, Flanged and Threaded Ends	MSS SP-70
Cast-Iron Swing Check Valves, Flanged and Threaded Ends	MSS SP-71
Ball Valves with Flanged Butt-Welding Ends for General Service	MSS SP-72
Ball Valves Threaded, Socket-Welding, Solder Joint, Grooved and Flared Ends	MSS SP-110
Cast-Iron Plug Valves, Flanged and Threaded Ends	MSS SP-78
Bronze Gate, Globe, Angle, and Check Valves	MSS SP-80
Steel Valves, Socket Welding and Threaded Ends	ASME B16.34
Cast-Iron Globe and Angle Valves, Flanged and Threaded Ends	MSS SP-85
Backwater Valves	ASME A112.14.1
Vacuum Relief Valves	CSA/AM Z21.22
Water Heater Drain Valves	ASSE 1005
Trap Seal Primer Valves	ASSE 1018
Temperature and Pressure Relief Valves for Hot Water Supply Systems	CSA/AM Z21.22
Temperature and Pressure Relief Valves for Automatically Fired Hot Water Boilers	ASME CSD-1 Safety Code No., Part CW, Article 5

### 2.3.1 Wall Faucets

Wall faucets with vacuum-breaker backflow preventer shall be brass with 3/4 inch male inlet threads, hexagon shoulder, and 3/4 inch hose connection. Faucet handle shall be securely attached to stem.

### 2.3.2 Wall Hydrants (Frostproof)

ASSE 1019 with vacuum-breaker backflow preventer shall have a nickel-brass or nickel-bronze wall plate or flange with nozzle and detachable key handle. A brass or bronze operating rod shall be provided within a galvanized iron casing of sufficient length to extend through the wall so that the valve is inside the building, and the portion of the hydrant between the outlet and valve is self-draining. A brass or bronze valve with coupling and union elbow having metal-to-metal seat shall be provided. Valve rod and seat washer shall be removable through the face of the hydrant. The hydrant shall have 3/4 inch exposed hose thread on spout and 3/4 inch male pipe thread on inlet.

### 2.3.3 Relief Valves

Water heaters and hot water storage tanks shall have a combination pressure and temperature (P&T) relief valve. The pressure relief element of a P&T relief valve shall have adequate capacity to prevent excessive pressure buildup in the system when the system is operating at the maximum rate of heat input. The temperature element of a P&T relief valve shall have a relieving capacity which is at least equal to the total input of the heaters when operating at their maximum capacity. Relief valves shall be rated according to CSA/AM Z21.22. Relief valves for systems where the maximum rate of heat input is less than 200,000 Btuh shall have 3/4 inch minimum inlets, and 3/4 inch outlets. Relief valves for systems where the maximum rate of heat input is greater than 200,000 Btuh shall have 1 inch minimum inlets, and 1 inch outlets. The discharge pipe from the relief valve shall be the size of the valve outlet.

### 2.3.4 Thermostatic Mixing Valves

Provide thermostatic mixing valve for lavatory faucets. Mixing valves, thermostatic type, pressure-balanced or combination thermostatic and pressure-balanced shall be line size and shall be constructed with rough or finish bodies either with or without plating. Each valve shall be constructed to control the mixing of hot and cold water and to deliver water at a desired temperature regardless of pressure or input temperature changes. The control element shall be of an approved type. The body shall be of heavy cast bronze, and interior parts shall be brass, bronze, corrosion-resisting steel or copper. The valve shall be equipped with necessary stops, check valves, unions, and sediment strainers on the inlets. Mixing valves shall maintain water temperature within 5 degrees F of any setting.

## 2.4 FIXTURES

Fixtures shall be water conservation type, in accordance with ICC IPC. Fixtures for use by the physically handicapped shall be in accordance with ICC A117.1. Vitreous china, nonabsorbent, hard-burned, and vitrified throughout the body shall be provided. Porcelain enameled ware shall have specially selected, white, acid-resisting enamel coating evenly applied on surfaces. No fixture will be accepted that shows cracks, crazes, blisters, thin spots, or other flaws. Fixtures shall be equipped with appurtenances such as traps, faucets, stop valves, and drain fittings. Each fixture and piece of equipment requiring connections to the drainage system, except grease interceptors, shall be equipped with a trap. Brass expansion or toggle bolts capped with acorn nuts shall be provided for supports, and polished chromium-plated pipe, valves, and fittings shall be provided where

exposed to view. Fixtures with the supply discharge below the rim shall be equipped with backflow preventers. Internal parts of flush and/or flushometer valves, shower mixing valves, shower head face plates, pop-up stoppers of lavatory waste drains, and pop-up stoppers and overflow tees and shoes of bathtub waste drains may contain acetal resin, fluorocarbon, nylon, acrylonitrile-butadiene-styrene (ABS) or other plastic material, if the material has provided satisfactory service under actual commercial or industrial operating conditions for not less than 2 years or shall be copper alloy with all visible surfaces chrome plated. Plastic in contact with hot water shall be suitable for 180 degrees F water temperature.]

#### 2.4.1 Automatic Controls

Provide automatic, sensor operated faucets and flush valves to comply with ASSE 1037 and UL 1951 for lavatory faucets, urinals, and water closets. Flushing and faucet systems shall consist of solenoid-activated valves with light beam sensors. Flush valve for water closet shall include an override pushbutton. Flushing devices shall be provided as described in paragraph FIXTURES AND FIXTURE TRIMMINGS.

#### 2.4.2 Flush Valve Water Closets

ASME A112.19.2, white vitreous china, siphon jet, elongated bowl, floor-mounted, floor outlet or wall mounted, wall outlet, based on application. Top of toilet seat height above floor shall be 14 to 15 inches, except 17 to 19 inches for wheelchair water closets. Provide wax bowl ring including plastic sleeve. Water flushing volume of the water closet and flush valve combination shall not exceed 1.6 gallons per flush. Provide white solid plastic elongated open-front seat. Provide large diameter flush valve including angle control-stop valve, vacuum breaker, tail pieces, slip nuts, and wall plates; exposed to view components shall be chromium-plated or polished stainless steel. Flush valves shall be nonhold-open type. Mount flush valves not less than 11 inches above the fixture. Mounted height of flush valve shall not interfere with the hand rail in ADA stalls. Provide solenoid-activated flush valves including electrical-operated light-beam-sensor to energize the solenoid.

#### 2.4.3 Flush Valve Urinals

ASME A112.19.2, white vitreous china, wall-mounted, wall outlet, siphon jet, integral trap, and extended side shields. Provide urinal with the rim 17 inches above the floor. Water flushing volume of the urinal and flush valve combination shall not exceed 1.0 gallons per flush. Provide ASME A112.6.1M concealed chair carriers with vertical steel pipe supports. Provide large diameter flush valve including angle control-stop valve, vacuum breaker, tail pieces, slip nuts, and wall plates; exposed to view components shall be chromium-plated or polished stainless steel. Flush valves shall be nonhold-open type. Mount flush valves not less than 11 inches above the fixture. Provide solenoid-activated flush valves including electrical-operated light-beam-sensor to energize the solenoid.

#### 2.4.4 Wheelchair Flush Valve Type Urinals

ASME A112.19.2, white vitreous china, wall-mounted, wall outlet, blowout action, integral trap, elongated projecting bowl, 20 inches long from wall to front of flare, and ASME A112.19.5 trim. Provide large diaphragm (not less than 2.625 inches upper chamber inside diameter at the point where the diaphragm is sealed between the upper and lower chambers), nonhold-open

flush valve of chrome plated cast brass conforming to ASTM B 584, including vacuum breaker and angle control-stop valve with back check. The water flushing volume of the flush valve and urinal combination shall not exceed 1.0 gallon per flush. Furnish urinal manufacturer's certification of conformance. Provide ASME A112.6.1M concealed chair carriers. Mount urinal with front rim a maximum of 17 inches above floor and flush valve handle a maximum of 44 inches above floor for use by handicapped on wheelchair. Provide solenoid-activated flush valves including electrical-operated light-beam-sensor to energize the solenoid.

#### 2.4.5 Wall Hung Lavatories

ASME A112.19.2, white vitreous china, straight back type, minimum dimensions of 19 inches, wide by 17 inches front to rear, with supply openings for use with top mounted centerset faucets, and openings for concealed arm carrier installation. Provide aerator with faucet. Water flow rate shall not exceed 1.0 gpm when measured at a flowing water pressure of 60 psi. Provide ASME A112.6.1M concealed chair carriers with vertical steel pipe supports and concealed arms for the lavatory. Mount lavatory with the front rim 34 inches above floor and with 29 inches minimum clearance from bottom of the front rim to floor. Provide top-mounted solenoid-activated lavatory faucets including electrical-operated light-beam-sensor to energize the solenoid.

#### 2.4.6 Kitchen Sinks

ASME A112.19.3, 20 gage stainless steel with integral mounting rim for flush installation, minimum dimensions of 33 inches wide by 21 inches front to rear, two compartments, with undersides fully sound deadened, with supply openings for use with top mounted washerless sink faucets with hose spray, and with 3.5 inch drain outlet. Provide aerator with faucet. Water flow rate shall not exceed 1.5 gpm when measured at a flowing water pressure of 60 psi. Provide stainless steel drain outlets and stainless steel cup strainers. Provide separate 1.5 inch P-trap and drain piping to vertical vent piping from each compartment. Provide top mounted washerless sink faucets with hose spray. Provide UL 430 waste disposer in right compartment.

#### 2.4.7 Service Sinks

ASME A112.19.2, white vitreous china with integral back and wall hanger supports, minimum dimensions of 22 inches wide by 20 inches front to rear, with two supply openings in 10 inch high back. Provide floor supported wall outlet cast iron P-trap and stainless steel rim guards as recommended by service sink manufacturer. Provide back mounted washerless service sink faucets with vacuum breaker and 0.75 inch external hose threads.

#### 2.4.8 Drinking-Water Coolers

AHRI 1010 with more than a single thickness of metal between the potable water and the refrigerant in the heat exchanger, wall-hung, bubbler style, air-cooled condensing unit, 4.75 gph minimum capacity, stainless steel splash receptor and basin, and stainless steel cabinet. Bubblers shall be controlled by push levers or push bars, front mounted or side mounted near the front edge of the cabinet. Bubbler spouts shall be mounted at maximum of 36 inches above floor and at front of unit basin. Spouts shall direct water flow at least 4 inches above unit basin and trajectory parallel or nearly parallel to the front of unit. Provide ASME A112.6.1M concealed

steel pipe chair carriers.

#### 2.4.9 Wheelchair Drinking Water cooler

AHRI 1010, wall-mounted bubbler style with ASME A112.6.1M concealed chair carrier, air-cooled condensing unit, 4.75 gph minimum capacity, stainless steel splash receptor, and all stainless steel cabinet, with 27 inch minimum knee clearance from front bottom of unit to floor and 36 inch maximum spout height above floor. Bubblers shall also be controlled by push levers, by push bars, or touch pads one on each side or one on front and both sides of the cabinet.

#### 2.4.10 Precast Terrazzo Mop Sinks

Terrazzo shall be made of marble chips cast in white portland cement to produce 3000 psi minimum compressive strength 7 days after casting. Provide floor or wall outlet copper alloy body drain cast integral with terrazzo, with polished stainless steel strainers.

#### 2.4.11 Emergency Eyewash and Shower

ISEA Z358.1, floor supported free standing unit. Provide deluge shower head, stay-open ball valve operated by pull rod and ring or triangular handle. Provide eyewash and stay-open ball valve operated by foot treadle or push handle.

### 2.5 BACKFLOW PREVENTERS

Backflow preventers shall be approved and listed by the Foundation For Cross-Connection Control & Hydraulic Research. Reduced pressure principle assemblies, double check valve assemblies, atmospheric (nonpressure) type vacuum breakers, and pressure type vacuum breakers shall be tested, approved, and listed in accordance with FCCCHR Manual. Backflow preventers with intermediate atmospheric vent shall conform to ASSE 1012. Reduced pressure principle backflow preventers shall conform to ASSE 1013. Hose connection vacuum breakers shall conform to ASSE 1011. Pipe applied atmospheric type vacuum breakers shall conform to ASSE 1001. Pressure vacuum breaker assembly shall conform to ASSE 1020. Air gaps in plumbing systems shall conform to ASME A112.1.2.

### 2.6 DRAINS

#### 2.6.1 Floor and Shower Drains

Floor and shower drains shall consist of a galvanized body, integral seepage pan, and adjustable perforated or slotted chromium-plated bronze, nickel-bronze, or nickel-brass strainer, consisting of grate and threaded collar. Floor drains shall be cast iron except where metallic waterproofing membrane is installed. Drains shall be of double drainage pattern for embedding in the floor construction. The seepage pan shall have weep holes or channels for drainage to the drainpipe. The strainer shall be adjustable to floor thickness. A clamping device for attaching flashing or waterproofing membrane to the seepage pan without damaging the flashing or waterproofing membrane shall be provided when required. Drains shall be provided with threaded connection. Between the drain outlet and waste pipe, a neoprene rubber gasket conforming to ASTM C 564 may be installed, provided that the drain is specifically designed for the rubber

gasket compression type joint. Floor and shower drains shall conform to ASME A112.6.3. [Provide drain with trap primer connection, trap primer, and connection piping. Primer shall meet ASSE 1018.]

#### 2.6.1.1 Metallic Shower Pan Drains

Where metallic shower pan membrane is installed, polyethylene drain with corrosion-resistant screws securing the clamping device shall be provided. Polyethylene drains shall have fittings to adapt drain to waste piping. Polyethylene for floor drains shall conform to ASTM D 1248. Drains shall have separate cast-iron "P" trap, circular body, seepage pan, and strainer, unless otherwise indicated.

#### 2.6.1.2 Drains and Backwater Valves

Drains and backwater valves installed in connection with waterproofed floors or shower pans shall be equipped with bolted-type device to securely clamp flashing.

#### 2.6.2 Bathtub and Shower Faucets and Drain Fittings

Provide single control pressure equalizing bathtub and shower faucets with body mounted from behind the wall with threaded connections. Provide ball joint self-cleaning shower heads. Provide shower heads which deliver a maximum of 2.2 GPM at 80 PSI per Energy Star requirements. Provide tubing mounted from behind the wall between bathtub faucets and shower heads and bathtub diverter spouts. Provide separate globe valves or angle valves with union connections in each supply to faucet.

#### 2.6.3 Area Drains

Area drains shall be plain pattern with polished stainless steel perforated or slotted grate and bottom outlet. The drain shall be circular or square with a 12 inch nominal overall width or diameter and 10 inch nominal overall depth. Drains shall be cast iron with manufacturer's standard coating. Grate shall be easily lifted out for cleaning. Outlet shall be suitable for inside caulked connection to drain pipe. Drains shall conform to ASME A112.6.3.

#### 2.6.4 Floor Sinks

Floor sinks shall be square, with 12 inch nominal overall width or diameter and 10 inch nominal overall depth. Floor sink shall have an acid-resistant enamel interior finish with cast-iron body, and perforated grate of cast iron in industrial areas and stainless steel in finished areas. The outlet pipe size shall be as indicated or of the same size as the connecting pipe.

#### 2.6.5 Sight Drains

Sight drains shall consist of body, integral seepage pan, and adjustable strainer with perforated or slotted grate and funnel extension. The strainer shall have a threaded collar to permit adjustment to floor thickness. Drains shall be of double drainage pattern suitable for embedding in the floor construction. A clamping device for attaching flashing or waterproofing membrane to the seepage pan without damaging the flashing or membrane shall be provided for other than concrete

construction. Drains shall have a galvanized heavy cast-iron body and seepage pan and chromium-plated bronze, nickel-bronze, or nickel-brass strainer and funnel combination. Drains shall be provided with threaded connection and with a separate cast-iron "P" trap, unless otherwise indicated. Drains shall be circular, unless otherwise indicated. The funnel shall be securely mounted over an opening in the center of the strainer. Minimum dimensions shall be as follows:

Area of strainer and collar      36 square inches

Height of funnel      3-3/4 inches

Diameter of lower portion      2 inches  
of funnel

Diameter of upper portion      4 inches  
of funnel

## 2.7 SHOWER PAN

Shower pan may be copper, or nonmetallic material.

### 2.7.1 Sheet Copper

Sheet copper shall be 16 ounce weight.

### 2.7.2 Plasticized Polyvinyl Chloride Shower Pan Material

Material shall be sheet form. The material shall be 0.040 inch minimum thickness of plasticized polyvinyl chloride or chlorinated polyethylene and shall be in accordance with ASTM D 4551.

### 2.7.3 Nonplasticized Polyvinyl Chloride (PVC) Shower Pan Material

Material shall consist of a plastic waterproofing membrane in sheet form. The material shall be 0.040 inch minimum thickness of nonplasticized PVC and shall have the following minimum properties:

a. or ASTM D 638:

Ultimate Tensile Strength:      2600 psi  
Ultimate Elongation:              398 percent  
100 Percent Modulus:              445 psi

b. ASTM D 1004:

Tear Strength:                      300 pounds per inch

c. ASTM E 96/E 96M:

Permeance:                          0.008 perms

d. Other Properties:

Specific Gravity:                    1.29  
PVC Solvent:                        Weldable  
Cold Crack:                         minus -53 degrees F

Dimensional stability,  
212 degrees F minus 2.5 percent  
Hardness, Shore A: 89

## 2.8 TRAPS

Unless otherwise specified, traps shall be plastic per ASTM F 409 or copper-alloy adjustable tube type with slip joint inlet and swivel. Traps shall be without a cleanout. Provide traps with removable access panels for easy clean-out at sinks and lavatories. Tubes shall be copper alloy with walls not less than 0.032 inch thick within commercial tolerances, except on the outside of bends where the thickness may be reduced slightly in manufacture by usual commercial methods. Inlets shall have rubber washer and copper alloy nuts for slip joints above the discharge level. Swivel joints shall be below the discharge level and shall be of metal-to-metal or metal-to-plastic type as required for the application. Nuts shall have flats for wrench grip. Outlets shall have internal pipe thread, except that when required for the application, the outlets shall have sockets for solder-joint connections. The depth of the water seal shall be not less than 2 inches. The interior diameter shall be not more than 1/8 inch over or under the nominal size, and interior surfaces shall be reasonably smooth throughout. A copper alloy "P" trap assembly consisting of an adjustable "P" trap and threaded trap wall nipple with cast brass wall flange shall be provided for lavatories. The assembly shall be a standard manufactured unit and may have a rubber-gasketed swivel joint.

## 2.9 INTERCEPTORS

### 2.9.2 Oil Interceptor

Cast iron or welded steel, coated inside and outside with white acid resistant epoxy, with internal air relief bypass, bronze cleanout plug, double wall trap seal, removable combination pressure equalizing and flow diffusing baffle and sediment bucket, horizontal baffle, adjustable oil draw-off and vent connections on either side, gas and watertight gasketed nonskid cover, and flow control fitting.

## 2.10 WATER HEATERS

Water heater types and capacities shall be as indicated. Each water heater shall have replaceable anodes. Each primary water heater shall have controls with an adjustable range that includes 90 to 160 degrees F. Each gas-fired water heater and booster water heater shall have controls with an adjustable range that includes 120 to 180 degrees F. Hot water systems utilizing recirculation systems shall be tied into building off-hour controls. The thermal efficiencies and standby heat losses shall conform to TABLE III for each type of water heater specified. The only exception is that storage water heaters and hot water storage tanks having more than 500 gallons storage capacity need not meet the standard loss requirement if the tank surface area is insulated to R-12.5 and if a standing light is not used. A factory pre-charged expansion tank shall be installed on the cold water supply to each water heater. Expansion tanks shall be specifically designed for use on potable water systems and shall be rated for 200 degrees F water temperature and 150 psi working pressure. The expansion tank size and acceptance volume shall be as indicated.

### 2.10.1 Automatic Storage Type

Heaters shall be complete with control system, and shall have ASME rated combination pressure and temperature relief valve.

#### 2.10.1.3 Electric Type

Electric type water heaters shall conform to UL 174 with dual heating elements. Each element shall be 4.5 KW. The elements shall be wired so that only one element can operate at a time.

### 2.10.2 Electric Instantaneous Water Heaters (Tankless)

UL 499 and UL listed flow switch activated, tankless electric instantaneous water heater for wall mounting below sink or lavatory.

## 2.11 PUMPS

### 2.11.1 Circulating Pumps

Domestic hot water circulating pumps shall be electrically driven, single-stage, centrifugal, with mechanical seals, suitable for the intended service. Pump and motor shall be supported by the piping on which it is installed. The shaft shall be one-piece, heat-treated, corrosion-resisting steel with impeller and smooth-surfaced housing of bronze.

Motor shall be totally enclosed, fan-cooled and shall have sufficient horsepower for the service required. Each pump motor shall be equipped with an across-the-line magnetic controller in a NEMA 250, Type 1 enclosure with "START-STOP" switch in cover.

## 2.12 COMPRESSED AIR SYSTEM

### 2.12.1 Air Compressors

Air compressor unit shall be a factory-packaged assembly, including motor controls, switches, wiring, accessories, and motor controllers, in a NEMA 250, Type 1 or 4 enclosure. Tank-mounted air compressors shall be manufactured to comply with UL listing requirements. Air compressors shall have manufacturer's name and address, together with trade name, and catalog number on a nameplate securely attached to the equipment. Each compressor shall start and stop automatically at upper and lower pressure limits of the system. Guards shall shield exposed moving parts. An intake air filter and silencer shall be provided with each compressor. Aftercooler and moisture separator shall be installed between compressors and air receiver to remove moisture and oil condensate before the air enters the receiver. Aftercoolers shall be either air- or water-cooled, as indicated. The air shall pass through a sufficient number of tubes to affect cooling. Tubes shall be sized to give maximum heat transfer. Water to unit shall be controlled by a solenoid or pneumatic valve, which opens when the compressors start and closes when the compressors shut down. Cooling capacity of the aftercooler shall be sized for the total capacity of the compressors. Means shall be provided for draining condensed moisture from the receiver by an automatic float type trap. Capacities of air compressors and receivers shall be as indicated.

### 2.12.2 Air Receivers

Receivers shall be designed for 200 psi working pressure. Receivers shall be factory air tested to 1-1/2 times the working pressure. Receivers shall be equipped with safety relief valves and accessories, including pressure gauges and automatic and manual drains. The outside of air receivers may be galvanized or supplied with commercial enamel finish. Receivers shall be designed and constructed in accordance with ASME BPVC SEC VIII D1 and shall have the design working pressures specified herein. A display of the ASME seal on the receiver or a certified test report from an approved independent testing laboratory indicating conformance to the ASME Code shall be provided.

#### 2.12.3 Intake Air Supply Filter

Dry type air filter shall be provided having a collection efficiency of 99 percent of particles larger than 10 microns. Filter body and media shall withstand a maximum 125 psi, capacity as indicated.

#### 2.12.4 Pressure Regulators

The air system shall be provided with the necessary regulator valves to maintain the desired pressure for the installed equipment. Regulators shall be designed for a maximum inlet pressure of 125 psi and a maximum temperature of 200 degrees F. Regulators shall be single-seated, pilot-operated with valve plug, bronze body and trim or equal, and threaded connections. The regulator valve shall include a pressure gauge and shall be provided with an adjustment screw for adjusting the pressure differential from 0 to 125 psi. Regulator shall be sized as indicated.

#### 2.13 DOMESTIC WATER SERVICE METER

Cold water meters 2 inches and smaller shall be positive displacement type conforming to AWWA C700. Cold water meters 2-1/2 inches and larger shall be turbine type conforming to AWWA C701. Meter register may be round or straight reading type, as provided by the local utility. Meter shall be provided with a pulse generator, remote readout register and all necessary wiring and accessories.

#### 2.14 ELECTRICAL WORK

Provide electrical motor driven equipment specified complete with motors, motor starters, and controls as specified herein and in Section 26 20 00, INTERIOR DISTRIBUTION SYSTEM. Provide internal wiring for components of packaged equipment as an integral part of the equipment. Provide [high efficiency type, ]single-phase, fractional-horsepower alternating-current motors, including motors that are part of a system, corresponding to the applications in accordance with NEMA MG 11. [In addition to the requirements of Section 26 20 00, INTERIOR DISTRIBUTION SYSTEM, provide polyphase, squirrel-cage medium induction motors with continuous ratings, including motors that are part of a system, that meet the efficiency ratings for premium efficiency motors in accordance with NEMA MG 1. ] Provide motors in accordance with NEMA MG 1 and of sufficient size to drive the load at the specified capacity without exceeding the nameplate rating of the motor.

Motors shall be rated for continuous duty with the enclosure specified. Motor duty requirements shall allow for maximum frequency start-stop operation and minimum encountered interval between start and stop. Motor torque shall be capable of accelerating the connected load within 20

seconds with 80 percent of the rated voltage maintained at motor terminals during one starting period. Motor bearings shall be fitted with grease supply fittings and grease relief to outside of the enclosure.

Controllers and contactors shall have auxiliary contacts for use with the controls provided. Manual or automatic control and protective or signal devices required for the operation specified and any control wiring required for controls and devices specified, but not shown, shall be provided. For packaged equipment, the manufacturer shall provide controllers, including the required monitors and timed restart.

Power wiring and conduit for field installed equipment shall be provided under and conform to the requirements of Section 26 20 00 INTERIOR DISTRIBUTION SYSTEM.

## 2.15 MISCELLANEOUS PIPING ITEMS

### 2.15.1 Escutcheon Plates

Provide one piece or split hinge metal plates for piping entering floors, walls, and ceilings in exposed spaces. Provide chromium-plated on copper alloy plates or polished stainless steel finish in finished spaces. Provide paint finish on plates in unfinished spaces.

### 2.15.2 Pipe Sleeves

Provide where piping passes entirely through walls, ceilings, roofs, and floors. Sleeves are not required where [supply] drain, waste, and vent (DWV) piping passes through concrete floor slabs located on grade, except where penetrating a membrane waterproof floor.

#### 2.15.2.1 Sleeves in Masonry and Concrete

Provide steel pipe sleeves or schedule 40 PVC plastic pipe sleeves. Sleeves are not required where drain, waste, and vent (DWV) piping passes through concrete floor slabs located on grade. Core drilling of masonry and concrete may be provided in lieu of pipe sleeves when cavities in the core-drilled hole are completely grouted smooth.

#### 2.15.2.2 Sleeves Not in Masonry and Concrete

Provide 26 gage galvanized steel sheet or PVC plastic pipe sleeves.

### 2.15.3 Pipe Hangers (Supports)

Provide MSS SP-58 and MSS SP-69, Type 1 with adjustable type steel support rods, except as specified or indicated otherwise. Attach to steel joists with Type 19 or 23 clamps and retaining straps. Attach to Steel W or S beams with Type 21, 28, 29, or 30 clamps. Attach to steel angles and vertical web steel channels with Type 20 clamp with beam clamp channel adapter. Attach to horizontal web steel channel and wood with drilled hole on centerline and double nut and washer. Attach to concrete with Type 18 insert or drilled expansion anchor. Provide Type 40 insulation protection shield for insulated piping.

### 2.15.4 Nameplates

Provide 0.125 inch thick melamine laminated plastic nameplates, black matte finish with white center core, for equipment, gages, thermometers, and valves; valves in supplies to faucets will not require nameplates. Accurately align lettering and engrave minimum of 0.25 inch high normal block lettering into the white core. Minimum size of nameplates shall be 1.0 by 2.5 inches. Key nameplates to a chart and schedule for each system. Frame charts and schedules under glass and place where directed near each system. Furnish two copies of each chart and schedule.

#### 2.15.5 Labels

Provide labels for sensor operators at flush valves and faucets. Include the following information on each label:

- a. Identification of the sensor and its operation with [graphic] [written] [Braille] description.
- b. Range of the sensor.
- c. Battery replacement schedule.

### PART 3 EXECUTION

#### 3.1 GENERAL INSTALLATION REQUIREMENTS

Piping located in air plenums shall conform to NFPA 90A requirements. Piping located in shafts that constitute air ducts or that enclose air ducts shall be noncombustible in accordance with NFPA 90A. Installation of plastic pipe where in compliance with NFPA may be installed in accordance with PPFA-01. The plumbing system shall be installed complete with necessary fixtures, fittings, traps, valves, and accessories. Water and drainage piping shall be extended 5 feet outside the building, unless otherwise indicated. A gate valve or full port ball valve and drain shall be installed on the water service line inside the building approximately 6 inches above the floor from point of entry. Piping shall be connected to the exterior service lines or capped or plugged if the exterior service is not in place. Sewer and water pipes shall be laid in separate trenches, except when otherwise shown. Exterior underground utilities shall be at least 12 inches below the finish grade or as indicated on the drawings. If trenches are closed or the pipes are otherwise covered before being connected to the service lines, the location of the end of each plumbing utility shall be marked with a stake or other acceptable means. Valves shall be installed with control no lower than the valve body.

##### 3.1.1 Water Pipe, Fittings, and Connections

###### 3.1.1.1 Utilities

The piping shall be extended to fixtures, outlets, and equipment. The hot-water and cold-water piping system shall be arranged and installed to permit draining. The supply line to each item of equipment or fixture, except faucets, flush valves, or other control valves which are supplied with integral stops, shall be equipped with a shutoff valve to enable isolation of the item for repair and maintenance without interfering with operation of other equipment or fixtures. Supply piping to fixtures, faucets, hydrants, shower heads, and flushing devices shall be anchored to prevent movement.

#### 3.1.1.2 Cutting and Repairing

The work shall be carefully laid out in advance, and unnecessary cutting of construction shall be avoided. Damage to building, piping, wiring, or equipment as a result of cutting shall be repaired by mechanics skilled in the trade involved.

#### 3.1.1.3 Protection of Fixtures, Materials, and Equipment

Pipe openings shall be closed with caps or plugs during installation. Fixtures and equipment shall be tightly covered and protected against dirt, water, chemicals, and mechanical injury. Upon completion of the work, the fixtures, materials, and equipment shall be thoroughly cleaned, adjusted, and operated. Safety guards shall be provided for exposed rotating equipment.

#### 3.1.1.4 Mains, Branches, and Runouts

Piping shall be installed as indicated. Pipe shall be accurately cut and worked into place without springing or forcing. Structural portions of the building shall not be weakened. Aboveground piping shall run parallel with the lines of the building, unless otherwise indicated. Branch pipes from service lines may be taken from top, bottom, or side of main, using crossover fittings required by structural or installation conditions. Supply pipes, valves, and fittings shall be kept a sufficient distance from other work and other services to permit not less than 1/2 inch between finished covering on the different services. Bare and insulated water lines shall not bear directly against building structural elements so as to transmit sound to the structure or to prevent flexible movement of the lines. Water pipe shall not be buried in or under floors unless specifically indicated or approved. Changes in pipe sizes shall be made with reducing fittings. Use of bushings will not be permitted except for use in situations in which standard factory fabricated components are furnished to accommodate specific accepted installation practice. Change in direction shall be made with fittings, except that bending of pipe 4 inches and smaller will be permitted, provided a pipe bender is used and wide sweep bends are formed. The center-line radius of bends shall be not less than six diameters of the pipe. Bent pipe showing kinks, wrinkles, flattening, or other malformations will not be acceptable.

#### 3.1.1.5 Pipe Drains

Pipe drains indicated shall consist of 3/4 inch hose bibb with renewable seat and full port ball valve ahead of hose bibb. At other low points, 3/4 inch brass plugs or caps shall be provided. Disconnection of the supply piping at the fixture is an acceptable drain.

#### 3.1.1.6 Expansion and Contraction of Piping

Allowance shall be made throughout for expansion and contraction of water pipe. Each hot-water and hot-water circulation riser shall have expansion loops or other provisions such as offsets, changes in direction, etc., where indicated and/or required. Risers shall be securely anchored as required or where indicated to force expansion to loops. Branch connections from risers shall be made with ample swing or offset to avoid undue strain on fittings or short pipe lengths. Horizontal runs of pipe over 50 feet in length shall be anchored to the wall or the supporting construction about midway on the run to force expansion, evenly divided,

toward the ends. Sufficient flexibility shall be provided on branch runouts from mains and risers to provide for expansion and contraction of piping. Flexibility shall be provided by installing one or more turns in the line so that piping will spring enough to allow for expansion without straining. If mechanical grooved pipe coupling systems are provided, the deviation from design requirements for expansion and contraction may be allowed pending approval of Contracting Officer.

#### 3.1.1.7 Thrust Restraint

Plugs, caps, tees, valves and bends deflecting 11.25 degrees or more, either vertically or horizontally, in waterlines 4 inches in diameter or larger shall be provided with thrust blocks, where indicated, to prevent movement. Thrust blocking shall be concrete of a mix not leaner than: 1 cement, 2-1/2 sand, 5 gravel; and having a compressive strength of not less than 2000 psi after 28 days. Blocking shall be placed between solid ground and the fitting to be anchored. Unless otherwise indicated or directed, the base and thrust bearing sides of the thrust block shall be poured against undisturbed earth. The side of the thrust block not subject to thrust shall be poured against forms. The area of bearing will be as shown. Blocking shall be placed so that the joints of the fitting are accessible for repair. Steel rods and clamps, protected by galvanizing or by coating with bituminous paint, shall be used to anchor vertical down bends into gravity thrust blocks.

#### 3.1.1.8 Commercial-Type Water Hammer Arresters

Commercial-type water hammer arresters shall be provided on hot- and cold-water supplies and shall be located as generally indicated, with precise location and sizing to be in accordance with PDI WH 201. Water hammer arresters, where concealed, shall be accessible by means of access doors or removable panels. Commercial-type water hammer arresters shall conform to ASSE 1010. Vertical capped pipe columns will not be permitted.

#### 3.1.2 Compressed Air Piping (Non-Oil Free)

Compressed air piping shall be installed as specified for water piping and suitable for 125 psig working pressure. Compressed air piping shall have supply lines and discharge terminals legibly and permanently marked at both ends with the name of the system and the direction of flow.

#### 3.1.3 Joints

Installation of pipe and fittings shall be made in accordance with the manufacturer's recommendations. Mitering of joints for elbows and notching of straight runs of pipe for tees will not be permitted. Joints shall be made up with fittings of compatible material and made for the specific purpose intended.

##### 3.1.3.1 Threaded

Threaded joints shall have American Standard taper pipe threads conforming to ASME B1.20.1. Only male pipe threads shall be coated with graphite or with an approved graphite compound, or with an inert filler and oil, or shall have a polytetrafluoroethylene tape applied.

##### 3.1.3.2 Mechanical Couplings

Mechanical couplings may be used in conjunction with grooved pipe for aboveground, ferrous or non-ferrous, domestic hot and cold water systems, in lieu of unions, brazed, soldered, welded, flanged, or threaded joints.

Mechanical couplings are permitted in accessible locations including behind access plates. Flexible grooved joints will not be permitted, except as vibration isolators adjacent to mechanical equipment. Rigid grooved joints shall incorporate an angle bolt pad design which maintains metal-to-metal contact with equal amount of pad offset of housings upon installation to ensure positive rigid clamping of the pipe.

Designs which can only clamp on the bottom of the groove or which utilize gripping teeth or jaws, or which use misaligned housing bolt holes, or which require a torque wrench or torque specifications will not be permitted.

Rigid grooved pipe couplings shall be for use with grooved end pipes, fittings, valves and strainers. Rigid couplings shall be designed for not less than 125 psi service and appropriate for static head plus the pumping head, and shall provide a watertight joint.

Grooved fittings and couplings, and grooving tools shall be provided from the same manufacturer. Segmentally welded elbows shall not be used. Grooves shall be prepared in accordance with the coupling manufacturer's latest published standards. Grooving shall be performed by qualified grooving operators having demonstrated proper grooving procedures in accordance with the tool manufacturer's recommendations.

The Contracting Officer shall be notified 24 hours in advance of test to demonstrate operator's capability, and the test shall be performed at the work site, if practical, or at a site agreed upon. The operator shall demonstrate the ability to properly adjust the grooving tool, groove the pipe, and to verify the groove dimensions in accordance with the coupling manufacturer's specifications.

#### 3.1.3.3 Unions and Flanges

Unions, flanges and mechanical couplings shall not be concealed in walls, ceilings, or partitions. Unions shall be used on pipe sizes 2-1/2 inches and smaller; flanges shall be used on pipe sizes 3 inches and larger.

#### 3.1.3.4 Grooved Mechanical Joints

Grooves shall be prepared according to the coupling manufacturer's instructions. Grooved fittings, couplings, and grooving tools shall be products of the same manufacturer. Pipe and groove dimensions shall comply with the tolerances specified by the coupling manufacturer. The diameter of grooves made in the field shall be measured using a "go/no-go" gauge, vernier or dial caliper, narrow-land micrometer, or other method specifically approved by the coupling manufacturer for the intended application. Groove width and dimension of groove from end of pipe shall be measured and recorded for each change in grooving tool setup to verify compliance with coupling manufacturer's tolerances. Grooved joints shall not be used in concealed locations.

#### 3.1.3.5 Cast Iron Soil, Waste and Vent Pipe

Bell and spigot compression and hubless gasketed clamp joints for soil, waste and vent piping shall be installed per the manufacturer's recommendations.

#### 3.1.3.6 Copper Tube and Pipe

- a. Brazed. Brazed joints shall be made in conformance with AWS B2.2, MSS SP-73, and CDA A4015 with flux and are acceptable for all pipe sizes. Copper to copper joints shall include the use of copper-phosphorus or copper-phosphorus-silver brazing metal without flux. Brazing of dissimilar metals (copper to bronze or brass) shall include the use of flux with either a copper-phosphorus, copper-phosphorus-silver or a silver brazing filler metal.
- b. Soldered. Soldered joints shall be made with flux and are only acceptable for piping 2 inches and smaller. Soldered joints shall conform to ASME B31.5 and CDA A4015. Soldered joints shall not be used in compressed air piping between the air compressor and the receiver.
- c. Copper Tube Extracted Joint. Mechanically extracted joints shall be made in accordance with ICC IPC.
- d. Press connection. Copper press connections shall be made in **strict** accordance with the manufacturer's installation instructions for manufactured rated size. The joints shall be pressed using the tool(s) approved by the manufacturer **of that joint**. Minimum distance between fittings shall be in accordance with the manufacturer's requirements.

#### 3.1.3.7 Plastic Pipe

Acrylonitrile-Butadiene-Styrene (ABS) pipe shall have joints made with solvent cement. PVC and CPVC pipe shall have joints made with solvent cement elastomeric, threading, (threading of Schedule 80 Pipe is allowed only where required for disconnection and inspection; threading of Schedule 40 Pipe is not allowed), or mated flanged.

#### 3.1.3.10 Other Joint Methods

#### 3.1.4 Dissimilar Pipe Materials

Connections between ferrous and non-ferrous copper water pipe shall be made with dielectric unions or flange waterways. Dielectric waterways shall have temperature and pressure rating equal to or greater than that specified for the connecting piping. Waterways shall have metal connections on both ends suited to match connecting piping. Dielectric waterways shall be internally lined with an insulator specifically designed to prevent current flow between dissimilar metals. Dielectric flanges shall meet the performance requirements described herein for dielectric waterways. Connecting joints between plastic and metallic pipe shall be made with transition fitting for the specific purpose.

#### 3.1.5 Pipe Sleeves and Flashing

Pipe sleeves shall be furnished and set in their proper and permanent

location.

#### 3.1.5.1 Sleeve Requirements

Unless indicated otherwise, provide pipe sleeves meeting the following requirements:

Secure sleeves in position and location during construction. Provide sleeves of sufficient length to pass through entire thickness of walls, ceilings, roofs, and floors.

A modular mechanical type sealing assembly may be installed in lieu of a waterproofing clamping flange and caulking and sealing of annular space between pipe and sleeve. The seals shall consist of interlocking synthetic rubber links shaped to continuously fill the annular space between the pipe and sleeve using galvanized steel bolts, nuts, and pressure plates. The links shall be loosely assembled with bolts to form a continuous rubber belt around the pipe with a pressure plate under each bolt head and each nut. After the seal assembly is properly positioned in the sleeve, tightening of the bolt shall cause the rubber sealing elements to expand and provide a watertight seal between the pipe and the sleeve. Each seal assembly shall be sized as recommended by the manufacturer to fit the pipe and sleeve involved.

Sleeves shall not be installed in structural members, except where indicated or approved. Rectangular and square openings shall be as detailed. Each sleeve shall extend through its respective floor, or roof, and shall be cut flush with each surface, except for special circumstances. Pipe sleeves passing through floors in wet areas such as mechanical equipment rooms, lavatories, kitchens, and other plumbing fixture areas shall extend a minimum of 4 inches above the finished floor.

Unless otherwise indicated, sleeves shall be of a size to provide a minimum of one inch clearance between bare pipe or insulation and inside of sleeve or between insulation and inside of sleeve. Sleeves in bearing walls and concrete slab on grade floors shall be steel pipe or cast-iron pipe. Sleeves in nonbearing walls or ceilings may be steel pipe, cast-iron pipe, galvanized sheet metal with lock-type longitudinal seam, or plastic.

Except as otherwise specified, the annular space between pipe and sleeve, or between jacket over insulation and sleeve, shall be sealed as indicated with sealants conforming to ASTM C 920 and with a primer, backstop material and surface preparation as specified in Section 07 92 00 JOINT SEALANTS. The annular space between pipe and sleeve, between bare insulation and sleeve or between jacket over insulation and sleeve shall not be sealed for interior walls which are not designated as fire rated.

#### 3.1.5.2 Flashing Requirements

Pipes passing through roof shall be installed through a 16 ounce copper flashing, each within an integral skirt or flange. Flashing shall be suitably formed, and the skirt or flange shall extend not less than 8 inches from the pipe and shall be set over the roof or floor membrane in a solid coating of bituminous cement. The flashing shall extend up the pipe a minimum of 10 inches. For cleanouts, the flashing shall be turned down into the hub and caulked after placing the ferrule. Pipes passing through pitched roofs shall be flashed, using lead or copper flashing, with an adjustable integral flange of adequate size to extend not less than 8

inches from the pipe in all directions and lapped into the roofing to provide a watertight seal. The annular space between the flashing and the bare pipe or between the flashing and the metal-jacket-covered insulation shall be sealed as indicated. Flashing for dry vents shall be turned down into the pipe to form a waterproof joint. Pipes, up to and including 10 inches in diameter, passing through roof or floor waterproofing membrane may be installed through a cast-iron sleeve with caulking recess, anchor lugs, flashing-clamp device, and pressure ring with brass bolts. Flashing shield shall be fitted into the sleeve clamping device. Pipes passing through wall waterproofing membrane shall be sleeved as described above. A waterproofing clamping flange shall be installed.

#### 3.1.5.3 Waterproofing

Waterproofing at floor-mounted water closets shall be accomplished by forming a flashing guard from soft-tempered sheet copper. The center of the sheet shall be perforated and turned down approximately 1-1/2 inches to fit between the outside diameter of the drainpipe and the inside diameter of the cast-iron or steel pipe sleeve. The turned-down portion of the flashing guard shall be embedded in sealant to a depth of approximately 1-1/2 inches; then the sealant shall be finished off flush to floor level between the flashing guard and drainpipe. The flashing guard of sheet copper shall extend not less than 8 inches from the drainpipe and shall be lapped between the floor membrane in a solid coating of bituminous cement. If cast-iron water closet floor flanges are used, the space between the pipe sleeve and drainpipe shall be sealed with sealant and the flashing guard shall be upturned approximately 1-1/2 inches to fit the outside diameter of the drainpipe and the inside diameter of the water closet floor flange. The upturned portion of the sheet fitted into the floor flange shall be sealed.

#### 3.1.5.4 Optional Counterflashing

Instead of turning the flashing down into a dry vent pipe, or caulking and sealing the annular space between the pipe and flashing or metal-jacket-covered insulation and flashing, counterflashing may be accomplished by utilizing the following:

- a. A standard roof coupling for threaded pipe up to 6 inches in diameter.
- b. A tack-welded or banded-metal rain shield around the pipe.

#### 3.1.5.5 Pipe Penetrations of Slab on Grade Floors

Where pipes, fixture drains, floor drains, cleanouts or similar items penetrate slab on grade floors, except at penetrations of floors with waterproofing membrane as specified in paragraphs Flashing Requirements and Waterproofing, a groove 1/4 to 1/2 inch wide by 1/4 to 3/8 inch deep shall be formed around the pipe, fitting or drain. The groove shall be filled with a sealant as specified in Section 07 92 00 JOINT SEALANTS.

#### 3.1.5.6 Pipe Penetrations

Provide sealants for all pipe penetrations. All pipe penetrations shall be sealed to prevent infiltration of air, insects, and vermin.

### 3.1.6 Fire Seal

Where pipes pass through fire walls, fire-partitions, fire-rated pipe chase walls or floors above grade, a fire seal shall be provided as specified in Section 07 84 00 FIRESTOPPING.

### 3.1.7 Supports

#### 3.1.7.1 General

Hangers used to support piping 2 inches and larger shall be fabricated to permit adequate adjustment after erection while still supporting the load. Pipe guides and anchors shall be installed to keep pipes in accurate alignment, to direct the expansion movement, and to prevent buckling, swaying, and undue strain. Piping subjected to vertical movement when operating temperatures exceed ambient temperatures shall be supported by variable spring hangers and supports or by constant support hangers. In the support of multiple pipe runs on a common base member, a clip or clamp shall be used where each pipe crosses the base support member. Spacing of the base support members shall not exceed the hanger and support spacing required for an individual pipe in the multiple pipe run. Threaded sections of rods shall not be formed or bent.

#### 3.1.7.2 Pipe Hangers, Inserts, and Supports

Installation of pipe hangers, inserts and supports shall conform to MSS SP-58 and MSS SP-69, except as modified herein.

- a. Types 5, 12, and 26 shall not be used.
- b. Type 3 shall not be used on insulated pipe.
- c. Type 18 inserts shall be secured to concrete forms before concrete is placed. Continuous inserts which allow more adjustment may be used if they otherwise meet the requirements for type 18 inserts.
- d. Type 19 and 23 C-clamps shall be torqued per MSS SP-69 and shall have both locknuts and retaining devices furnished by the manufacturer. Field-fabricated C-clamp bodies or retaining devices are not acceptable.
- e. Type 20 attachments used on angles and channels shall be furnished with an added malleable-iron heel plate or adapter.
- f. Type 24 may be used only on trapeze hanger systems or on fabricated frames.
- g. Type 39 saddles shall be used on insulated pipe 4 inches and larger when the temperature of the medium is 60 degrees F or higher. Type 39 saddles shall be welded to the pipe.
- h. Type 40 shields shall:
  - (1) Be used on insulated pipe less than 4 inches.
  - (2) Be used on insulated pipe 4 inches and larger when the temperature of the medium is 60 degrees F or less.

- (3) Have a high density insert for all pipe sizes. High density inserts shall have a density of 8 pcf or greater.
- i. Horizontal pipe supports shall be spaced as specified in MSS SP-69 and a support shall be installed not over 1 foot from the pipe fitting joint at each change in direction of the piping. Pipe supports shall be spaced not over 5 feet apart at valves. Operating temperatures in determining hanger spacing for PVC or CPVC pipe shall be 120 degrees F for PVC and 180 degrees F for CPVC. Horizontal pipe runs shall include allowances for expansion and contraction.
  - j. Vertical pipe shall be supported at each floor, except at slab-on-grade, at intervals of not more than 15 feet nor more than 8 feet from end of risers, and at vent terminations. Vertical pipe risers shall include allowances for expansion and contraction.
  - k. Type 35 guides using steel, reinforced polytetrafluoroethylene (PTFE) or graphite slides shall be provided to allow longitudinal pipe movement. Slide materials shall be suitable for the system operating temperatures, atmospheric conditions, and bearing loads encountered. Lateral restraints shall be provided as needed. Where steel slides do not require provisions for lateral restraint the following may be used:
    - (1) On pipe 4 inches and larger when the temperature of the medium is 60 degrees F or higher, a Type 39 saddle, welded to the pipe, may freely rest on a steel plate.
    - (2) On pipe less than 4 inches a Type 40 shield, attached to the pipe or insulation, may freely rest on a steel plate.
    - (3) On pipe 4 inches and larger carrying medium less than 60 degrees F a Type 40 shield, attached to the pipe or insulation, may freely rest on a steel plate.
  - l. Pipe hangers on horizontal insulated pipe shall be the size of the outside diameter of the insulation. The insulation shall be continuous through the hanger on all pipe sizes and applications.
  - m. Where there are high system temperatures and welding to piping is not desirable, the type 35 guide shall include a pipe cradle, welded to the guide structure and strapped securely to the pipe. The pipe shall be separated from the slide material by at least 4 inches or by an amount adequate for the insulation, whichever is greater.
  - n. Hangers and supports for plastic pipe shall not compress, distort, cut or abrade the piping, and shall allow free movement of pipe except where otherwise required in the control of expansion/contraction.

### 3.1.7.3 Structural Attachments

Attachment to building structure concrete and masonry shall be by cast-in concrete inserts, built-in anchors, or masonry anchor devices. Inserts and

anchors shall be applied with a safety factor not less than 5. Supports shall not be attached to metal decking. Supports shall not be attached to the underside of concrete filled floor or concrete roof decks unless approved by the Contracting Officer. Masonry anchors for overhead applications shall be constructed of ferrous materials only.

### 3.1.8 Welded Installation

Plumbing pipe weldments shall be as indicated. Changes in direction of piping shall be made with welding fittings only; mitering or notching pipe to form elbows and tees or other similar type construction will not be permitted. Branch connection may be made with either welding tees or forged branch outlet fittings. Branch outlet fittings shall be forged, flared for improvement of flow where attached to the run, and reinforced against external strains. Beveling, alignment, heat treatment, and inspection of weld shall conform to ASME B31.1. Weld defects shall be removed and repairs made to the weld, or the weld joints shall be entirely removed and rewelded. After filler metal has been removed from its original package, it shall be protected or stored so that its characteristics or welding properties are not affected. Electrodes that have been wetted or that have lost any of their coating shall not be used.

### 3.1.9 Pipe Cleanouts

Pipe cleanouts shall be the same size as the pipe except that cleanout plugs larger than 4 inches will not be required. A cleanout installed in connection with cast-iron soil pipe shall consist of a long-sweep 1/4 bend or one or two 1/8 bends extended to the place shown. An extra-heavy cast-brass or cast-iron ferrule with countersunk cast-brass head screw plug shall be caulked into the hub of the fitting and shall be flush with the floor. Cleanouts in connection with other pipe, where indicated, shall be T-pattern, 90-degree branch drainage fittings with cast-brass screw plugs, except plastic plugs shall be installed in plastic pipe. Plugs shall be the same size as the pipe up to and including 4 inches. Cleanout tee branches with screw plug shall be installed at the foot of soil and waste stacks, at the foot of interior downspouts, on each connection to building storm drain where interior downspouts are indicated, and on each building drain outside the building. Cleanout tee branches may be omitted on stacks in single story buildings with slab-on-grade construction or where less than 18 inches of crawl space is provided under the floor. Cleanouts on pipe concealed in partitions shall be provided with chromium plated bronze, nickel bronze, nickel brass or stainless steel flush type access cover plates. Round access covers shall be provided and secured to plugs with securing screw. Square access covers may be provided with matching frames, anchoring lugs and cover screws. Cleanouts in finished walls shall have access covers and frames installed flush with the finished wall. Cleanouts installed in finished floors subject to foot traffic shall be provided with a chrome-plated cast brass, nickel brass, or nickel bronze cover secured to the plug or cover frame and set flush with the finished floor. Heads of fastening screws shall not project above the cover surface. Where cleanouts are provided with adjustable heads, the heads shall be [cast iron] [or] [plastic].

## 3.2 WATER HEATERS AND HOT WATER STORAGE TANKS

### 3.2.1 Relief Valves

No valves shall be installed between a relief valve and its water heater or

storage tank. The P&T relief valve shall be installed where the valve actuator comes in contact with the hottest water in the heater. Whenever possible, the relief valve shall be installed directly in a tapping in the tank or heater; otherwise, the P&T valve shall be installed in the hot-water outlet piping. A vacuum relief valve shall be provided on the cold water supply line to the hot-water storage tank or water heater and mounted above and within 6 inches above the top of the tank or water heater.

### 3.2.2 Heat Traps

Piping to and from each water heater and hot water storage tank shall be routed horizontally and downward a minimum of 2 feet before turning in an upward direction.

### 3.2.3 Connections to Water Heaters

Connections of metallic pipe to water heaters shall be made with dielectric unions or flanges.

### 3.2.4 Expansion Tank

A pre-charged expansion tank shall be installed on the cold water supply between the water heater inlet and the cold water supply shut-off valve. The Contractor shall adjust the expansion tank air pressure, as recommended by the tank manufacturer, to match incoming water pressure.

## 3.3 FIXTURES AND FIXTURE TRIMMINGS

Polished chromium-plated pipe, valves, and fittings shall be provided where exposed to view. Angle stops, straight stops, stops integral with the faucets, or concealed type of lock-shield, and loose-key pattern stops for supplies with threaded, sweat or solvent weld inlets shall be furnished and installed with fixtures. Where connections between copper tubing and faucets are made by rubber compression fittings, a beading tool shall be used to mechanically deform the tubing above the compression fitting. Exposed traps and supply pipes for fixtures and equipment shall be connected to the rough piping systems at the wall, unless otherwise specified under the item. Floor and wall escutcheons shall be as specified. Drain lines and hot water lines of fixtures for handicapped personnel shall be insulated and do not require polished chrome finish. Plumbing fixtures and accessories shall be installed within the space shown.

### 3.3.1 Fixture Connections

Where space limitations prohibit standard fittings in conjunction with the cast-iron floor flange, special short-radius fittings shall be provided. Connections between earthenware fixtures and flanges on soil pipe shall be made gastight and watertight with a closet-setting compound or neoprene gasket and seal. Use of natural rubber gaskets or putty will not be permitted. Fixtures with outlet flanges shall be set the proper distance from floor or wall to make a first-class joint with the closet-setting compound or gasket and fixture used.

### 3.3.2 Flushometer Valves

Flushometer valves shall be secured to prevent movement by anchoring the

long finished top spud connecting tube to wall adjacent to valve with approved metal bracket. [Flushometer valves for water closets shall be installed 39 inches above the floor, except at water closets intended for use by the physically handicapped where flushometer valves shall be mounted at approximately 30 inches above the floor and arranged to avoid interference with grab bars.

### 3.3.3 Height of Fixture Rims Above Floor

Lavatories shall be mounted with rim 31 inches above finished floor. Wall-hung drinking fountains and water coolers shall be installed with rim 42 inches above floor. Wall-hung service sinks shall be mounted with rim 28 inches above the floor. Installation of fixtures for use by the physically handicapped shall be in accordance with ICC A117.1.

### 3.3.4 Shower Bath Outfits

The area around the water supply piping to the mixing valves and behind the escutcheon plate shall be made watertight by caulking or gasketing.

### 3.3.5 Fixture Supports

Fixture supports for off-the-floor lavatories, urinals, water closets, and other fixtures of similar size, design, and use, shall be of the chair-carrier type. The carrier shall provide the necessary means of mounting the fixture, with a foot or feet to anchor the assembly to the floor slab. Adjustability shall be provided to locate the fixture at the desired height and in proper relation to the wall. Support plates, in lieu of chair carrier, shall be fastened to the wall structure only where it is not possible to anchor a floor-mounted chair carrier to the floor slab.

#### 3.3.5.1 Support for Solid Masonry Construction

Chair carrier shall be anchored to the floor slab. Where a floor-anchored chair carrier cannot be used, a suitable wall plate shall be imbedded in the masonry wall.

#### 3.3.5.2 Support for Concrete-Masonry Wall Construction

Chair carrier shall be anchored to floor slab. Where a floor-anchored chair carrier cannot be used, a suitable wall plate shall be fastened to the concrete wall using through bolts and a back-up plate.

#### 3.3.5.3 Support for Steel Stud Frame Partitions

Chair carrier shall be used. The anchor feet and tubular uprights shall be of the heavy duty design; and feet (bases) shall be steel and welded to a square or rectangular steel tube upright. Wall plates, in lieu of floor-anchored chair carriers, shall be used only if adjoining steel partition studs are suitably reinforced to support a wall plate bolted to these studs.

#### 3.3.5.4 Wall-Mounted Water Closet Gaskets

Where wall-mounted water closets are provided, reinforced wax, treated felt, or neoprene gaskets shall be provided. The type of gasket furnished shall be as recommended by the chair-carrier manufacturer.

### 3.3.6 Backflow Prevention Devices

Plumbing fixtures, equipment, and pipe connections shall not cross connect or interconnect between a potable water supply and any source of nonpotable water. Backflow preventers shall be installed where indicated and in accordance with [ICC IPC] at all other locations necessary to preclude a cross-connect or interconnect between a potable water supply and any nonpotable substance. In addition backflow preventers shall be installed at all locations where the potable water outlet is below the flood level of the equipment, or where the potable water outlet will be located below the level of the nonpotable substance. Backflow preventers shall be located so that no part of the device will be submerged. Backflow preventers shall be of sufficient size to allow unrestricted flow of water to the equipment, and preclude the backflow of any nonpotable substance into the potable water system. Bypass piping shall not be provided around backflow preventers. Access shall be provided for maintenance and testing. Each device shall be a standard commercial unit.

### 3.3.7 Access Panels

Access panels shall be provided for concealed valves and controls, or any item requiring inspection or maintenance. Access panels shall be of sufficient size and located so that the concealed items may be serviced, maintained, or replaced. Access panels shall be as specified in[ Section 05 50 13 MISCELLANEOUS METAL FABRICATIONS][ Section 05 51 33 METAL LADDERS][ Section 05 52 00 METAL RAILINGS][ Section 05 51 00 METAL STAIRS].

### 3.3.8 Sight Drains

Sight drains shall be installed so that the indirect waste will terminate 2 inches above the flood rim of the funnel to provide an acceptable air gap.

### 3.3.9 Traps

Each trap shall be placed as near the fixture as possible, and no fixture shall be double-trapped. Traps installed on cast-iron soil pipe shall be cast iron. Traps installed on steel pipe or copper tubing shall be recess-drainage pattern, or brass-tube type. Traps installed on plastic pipe may be plastic conforming to ASTM D 3311. Traps for acid-resisting waste shall be of the same material as the pipe.

### 3.3.10 Shower Pans

Before installing shower pan, subfloor shall be free of projections such as nail heads or rough edges of aggregate. Drain shall be a bolt-down, clamping-ring type with weepholes, installed so the lip of the subdrain is flush with subfloor.

#### 3.3.10.1 General

The floor of each individual shower, the shower-area portion of combination shower and drying room, and the entire shower and drying room where the two are not separated by curb or partition, shall be made watertight with a shower pan fabricated in place. The shower pan material shall be cut to size and shape of the area indicated, in one piece to the maximum extent practicable, allowing a minimum of 6 inches for turnup on walls or

partitions, and shall be folded over the curb with an approximate return of 1/4 of curb height. The upstands shall be placed behind any wall or partition finish. Subflooring shall be smooth and clean, with nailheads driven flush with surface, and shall be sloped to drain. Shower pans shall be clamped to drains with the drain clamping ring.

#### 3.3.10.2 Metal Shower Pans

When a shower pan of required size cannot be furnished in one piece, metal pieces shall be joined with a flintlock seam and soldered or burned. The corners shall be folded, not cut, and the corner seam shall be soldered or burned. Pans, including upstands, shall be coated on all surfaces with one brush coat of asphalt. Asphalt shall be applied evenly at not less than 1 gallon per 50 square feet. A layer of felt covered with building paper shall be placed between shower pans and wood floors. The joining surfaces of metal pan and drain shall be given a brush coat of asphalt after the pan is connected to the drain.

#### 3.3.10.3 Nonplasticized Chlorinated Polyethylene Shower Pans

Corners of nonplasticized chlorinated polyethylene shower pans shall be folded against the upstand by making a pig-ear fold. Hot-air gun or heat lamp shall be used in making corner folds. Each pig-ear corner fold shall be nailed or stapled 1/2 inch from the upper edge to hold it in place. Nails shall be galvanized large-head roofing nails. On metal framing or studs, approved duct tape shall be used to secure pig-ear fold and membrane. Where no backing is provided between the studs, the membrane slack shall be taken up by pleating and stapling or nailing to studding 1/2 inch from upper edge. To adhere the membrane to vertical surfaces, the back of the membrane and the surface to which it will be applied shall be coated with adhesive that becomes dry to the touch in 5 to 10 minutes, after which the membrane shall be pressed into place. Surfaces to be solvent-welded shall be clean. Surfaces to be joined with xylene shall be initially sprayed and vigorously cleaned with a cotton cloth, followed by final coating of xylene and the joining of the surfaces by roller or equivalent means. If ambient or membrane temperatures are below 40 degrees F the membrane and the joint shall be heated prior to application of xylene. Heat may be applied with hot-air gun or heat lamp, taking precautions not to scorch the membrane. Adequate ventilation and wearing of gloves are required when working with xylene. Membrane shall be pressed into position on the drain body, and shall be cut and fit to match so that membrane can be properly clamped and an effective gasket-type seal provided. On wood subflooring, two layers of 15 pound dry felt shall be installed prior to installation of shower pan to ensure a smooth surface for installation.

#### 3.3.10.4 Nonplasticized Polyvinyl Chloride (PVC) Shower Pans

Nonplasticized PVC shall be turned up behind walls or wall surfaces a distance of not less than 6 inches in room areas and 3 inches above curb level in curbed spaces with sufficient material to fold over and fasten to outside face of curb. Corners shall be pig-ear type and folded between pan and studs. Only top 1 inch of upstand shall be nailed to hold in place. Nails shall be galvanized large-head roofing type. Approved duct tape shall be used on metal framing or studs to secure pig-ear fold and membrane. Where no backing is provided between studs, the membrane slack shall be taken up by pleating and stapling or nailing to studding at top inch of upstand. To adhere the membrane to vertical surfaces, the back of

the membrane and the surface to which it is to be applied shall be coated with adhesive that becomes dry to the touch in 5 to 10 minutes, after which the membrane shall be pressed into place. Trim for drain shall be exactly the size of drain opening. Bolt holes shall be pierced to accommodate bolts with a tight fit. Adhesive shall be used between pan and subdrain. Clamping ring shall be bolted firmly. A small amount of gravel or porous materials shall be placed at weepholes so that holes remain clear when setting bed is poured. Membrane shall be solvent welded with PVC solvent cement. Surfaces to be solvent welded shall be clean (free of grease and grime). Sheets shall be laid on a flat surface with an overlap of about 2 inches. Top edge shall be folded back and surface primed with a PVC primer. PVC cement shall be applied and surfaces immediately placed together, while still wet. Joint shall be lightly rolled with a paint roller, then as the joint sets shall be rolled firmly but not so hard as to distort the material. In long lengths, about 2 or 3 feet at a time shall be welded. On wood subflooring, two layers of 15 pound felt shall be installed prior to installation of shower pan to ensure a smooth surface installation.

### 3.4 VIBRATION-ABSORBING FEATURES

Mechanical equipment, including compressors and pumps, shall be isolated from the building structure by approved vibration-absorbing features, unless otherwise shown. Each foundation shall include an adequate number of standard isolation units. Each unit shall consist of machine and floor or foundation fastening, together with intermediate isolation material, and shall be a standard product with printed load rating. Piping connected to mechanical equipment shall be provided with flexible connectors.

#### 3.4.1 Tank- or Skid-Mounted Compressors

Floor attachment shall be as recommended by compressor manufacturer.

### 3.5 WATER METER REMOTE READOUT REGISTER

The remote readout register shall be mounted at the location indicated or as directed by the Contracting Officer.

### 3.6 IDENTIFICATION SYSTEMS

#### 3.6.1 Identification Tags

Identification tags made of brass, engraved laminated plastic, or engraved anodized aluminum, indicating service and valve number shall be installed on valves, except those valves installed on supplies at plumbing fixtures. Tags shall be 1-3/8 inch minimum diameter, and marking shall be stamped or engraved. Indentations shall be black, for reading clarity. Tags shall be attached to valves with No. 12 AWG, copper wire, chrome-plated beaded chain, or plastic straps designed for that purpose.

#### 3.6.2 Pipe Color Code Marking

Color code marking of piping shall be as specified in Section 09 90 00 PAINTS AND COATINGS.

#### 3.6.3 Color Coding Scheme for Locating Hidden Utility Components

Scheme shall be provided in buildings having suspended grid ceilings. The color coding scheme shall identify points of access for maintenance and operation of operable components which are not visible from the finished space and installed in the space directly above the suspended grid ceiling. The operable components shall include valves, dampers, switches, linkages and thermostats. The color coding scheme shall consist of a color code board and colored metal disks. Each colored metal disk shall be approximately 3/8 inch in diameter and secured to removable ceiling panels with fasteners. The fasteners shall be inserted into the ceiling panels so that the fasteners will be concealed from view. The fasteners shall be manually removable without tools and shall not separate from the ceiling panels when panels are dropped from ceiling height. Installation of colored metal disks shall follow completion of the finished surface on which the disks are to be fastened. The color code board shall have the approximate dimensions of 3 foot width, 30 inches height, and 1/2 inch thickness. The board shall be made of wood fiberboard and framed under glass or 1/16 inch transparent plastic cover. Unless otherwise directed, the color code symbols shall be approximately 3/4 inch in diameter and the related lettering in 1/2 inch high capital letters. The color code board shall be mounted and located in the mechanical or equipment room. The color code system shall be as indicated below:

Color	System	Item	Location
[_____]	[_____]	[_____]	[_____]

### 3.7 ESCUTCHEONS

Escutcheons shall be provided at finished surfaces where bare or insulated piping, exposed to view, passes through floors, walls, or ceilings, except in boiler, utility, or equipment rooms. Escutcheons shall be fastened securely to pipe or pipe covering and shall be satin-finish, corrosion-resisting steel, polished chromium-plated zinc alloy, or polished chromium-plated copper alloy. Escutcheons shall be either one-piece or split-pattern, held in place by internal spring tension or setscrew.

### 3.8 PAINTING

Painting of pipes, hangers, supports, and other iron work, either in concealed spaces or exposed spaces, is specified in Section 09 90 00 PAINTS AND COATINGS.

#### 3.8.1 PAINTING OF NEW EQUIPMENT

New equipment painting shall be factory applied or shop applied, and shall be as specified herein, and provided under each individual section.

##### 3.8.1.1 Factory Painting Systems

Manufacturer's standard factory painting systems may be provided subject to certification that the factory painting system applied will withstand 125 hours in a salt-spray fog test, except that equipment located outdoors shall withstand 500 hours in a salt-spray fog test. Salt-spray fog test shall be in accordance with ASTM B 117, and for that test the acceptance criteria shall be as follows: immediately after completion of the test, the paint shall show no signs of blistering, wrinkling, or cracking, and no loss of adhesion; and the specimen shall show no signs of rust creepage beyond 0.125 inch on either side of the scratch mark.

The film thickness of the factory painting system applied on the equipment shall not be less than the film thickness used on the test specimen. If manufacturer's standard factory painting system is being proposed for use on surfaces subject to temperatures above 120 degrees F, the factory painting system shall be designed for the temperature service.

#### 3.8.1.2 Shop Painting Systems for Metal Surfaces

Clean, pretreat, prime and paint metal surfaces; except aluminum surfaces need not be painted. Apply coatings to clean dry surfaces. Clean the surfaces to remove dust, dirt, rust, oil and grease by wire brushing and solvent degreasing prior to application of paint, except metal surfaces subject to temperatures in excess of 120 degrees F shall be cleaned to bare metal.

Where more than one coat of paint is specified, apply the second coat after the preceding coat is thoroughly dry. Lightly sand damaged painting and retouch before applying the succeeding coat. Color of finish coat shall be aluminum or light gray.

- a. Temperatures Less Than 120 Degrees F: Immediately after cleaning, the metal surfaces subject to temperatures less than 120 degrees F shall receive one coat of pretreatment primer applied to a minimum dry film thickness of 0.3 mil, one coat of primer applied to a minimum dry film thickness of one mil; and two coats of enamel applied to a minimum dry film thickness of one mil per coat.
- b. Temperatures Between 120 and 400 Degrees F: Metal surfaces subject to temperatures between 120 and 400 degrees F shall receive two coats of 400 degrees F heat-resisting enamel applied to a total minimum thickness of 2 mils.
- c. Temperatures Greater Than 400 Degrees F: Metal surfaces subject to temperatures greater than 400 degrees F shall receive two coats of 600 degrees F heat-resisting paint applied to a total minimum dry film thickness of 2 mils.

### 3.9 TESTS, FLUSHING AND DISINFECTION

#### 3.9.1 Plumbing System

The following tests shall be performed on the plumbing system in accordance with [ICC IPC], except that the drainage and vent system final test shall include the smoke test. The Contractor has the option to perform a peppermint test in lieu of the smoke test. If a peppermint test is chosen, the Contractor must submit a testing procedure to the Contracting Officer for approval.

- a. Drainage and Vent Systems Test. The final test shall include a smoke test.
- b. Building Sewers Tests.
- c. Water Supply Systems Tests.

##### 3.9.1.1 Test of Backflow Prevention Assemblies

Backflow prevention assembly shall be tested using gauges specifically designed for the testing of backflow prevention assemblies. Gauges shall be tested annually for accuracy in accordance with the University of Southern California's Foundation of Cross Connection Control and Hydraulic Research or the American Water Works Association Manual of Cross Connection (Manual M-14). Report form for each assembly shall include, as a minimum, the following:

Data on Device	Data on Testing Firm
Type of Assembly	Name
Manufacturer	Address
Model Number	Certified Tester
Serial Number	Certified Tester No.
Size	Date of Test
Location	
Test Pressure Readings	Serial Number and Test Data of
Gauges	

If the unit fails to meet specified requirements, the unit shall be repaired and retested.

#### 3.9.1.2 Shower Pans

After installation of the pan and finished floor, the drain shall be temporarily plugged below the weep holes. The floor area shall be flooded with water to a minimum depth of 1 inch for a period of 24 hours. Any drop in the water level during test, except for evaporation, will be reason for rejection, repair, and retest.

#### 3.9.1.3 Compressed Air Piping (Nonoil-Free)

Piping systems shall be filled with oil-free dry air or gaseous nitrogen to 150 psig and hold this pressure for 2 hours with no drop in pressure.

#### 3.9.2 Defective Work

If inspection or test shows defects, such defective work or material shall be replaced or repaired as necessary and inspection and tests shall be repeated. Repairs to piping shall be made with new materials. Caulking of screwed joints or holes will not be acceptable.

#### 3.9.3 System Flushing

##### 3.9.3.1 During Flushing

Before operational tests or disinfection, potable water piping system shall be flushed with [hot] potable water. Sufficient water shall be used to produce a water velocity that is capable of entraining and removing debris in all portions of the piping system. This requires simultaneous operation of all fixtures on a common branch or main in order to produce a flushing velocity of approximately 4 fps through all portions of the piping system. In the event that this is impossible due to size of system, the Contracting Officer (or the designated representative) shall specify the number of fixtures to be operated during flushing. Contractor shall provide adequate personnel to monitor the flushing operation and to ensure that drain lines are unobstructed in order to prevent flooding of the facility. Contractor shall be responsible for any flood damage resulting from flushing of the

system. Flushing shall be continued until entrained dirt and other foreign materials have been removed and until discharge water shows no discoloration. All faucets and drinking water fountains, to include any device considered as an end point device by NSF 61, Section 9, shall be flushed a minimum of 0.25 gallons per 24 hour period, ten times over a 14 day period.

#### 3.9.3.2 After Flushing

System shall be drained at low points. Strainer screens shall be removed, cleaned, and replaced. After flushing and cleaning, systems shall be prepared for testing by immediately filling water piping with clean, fresh potable water. Any stoppage, discoloration, or other damage to the finish, furnishings, or parts of the building due to the Contractor's failure to properly clean the piping system shall be repaired by the Contractor. When the system flushing is complete, the hot-water system shall be adjusted for uniform circulation. Flushing devices and automatic control systems shall be adjusted for proper operation according to manufacturer's instructions. Comply with ASHRAE 90.1 - IP for minimum efficiency requirements. Unless more stringent local requirements exist, lead levels shall not exceed limits established by 40 CFR 50.12 Part 141.80(c)(1). The water supply to the building shall be tested separately to ensure that any lead contamination found during potable water system testing is due to work being performed inside the building.

#### 3.9.4 Operational Test

Upon completion of flushing and prior to disinfection procedures, the Contractor shall subject the plumbing system to operating tests to demonstrate satisfactory installation, connections, adjustments, and functional and operational efficiency. Such operating tests shall cover a period of not less than 8 hours for each system and shall include the following information in a report with conclusion as to the adequacy of the system:

- a. Time, date, and duration of test.
- b. Water pressures at the most remote and the highest fixtures.
- c. Operation of each fixture and fixture trim.
- d. Operation of each valve, hydrant, and faucet.
- e. Pump suction and discharge pressures.
- f. Temperature of each domestic hot-water supply.
- g. Operation of each floor and roof drain by flooding with water.
- h. Operation of each vacuum breaker and backflow preventer.
- i. Complete operation of each water pressure booster system, including pump start pressure and stop pressure.
- j. Compressed air readings at each compressor and at each outlet. Each indicating instrument shall be read at 1/2 hour intervals. The report of the test shall be submitted in quadruplicate. The

Contractor shall furnish instruments, equipment, and personnel required for the tests; the Government will furnish the necessary water and electricity.

### 3.9.5 Disinfection

After operational tests are complete, the entire domestic hot- and cold-water distribution system shall be disinfected. System shall be flushed as specified, before introducing chlorinating material. The chlorinating material shall be hypochlorites or liquid chlorine. Except as herein specified, water chlorination procedure shall be in accordance with AWWA C651 and AWWA C652. The chlorinating material shall be fed into the water piping system at a constant rate at a concentration of at least 50 parts per million (ppm). A properly adjusted hypochlorite solution injected into the main with a hypochlorinator, or liquid chlorine injected into the main through a solution-feed chlorinator and booster pump, shall be used. If after the 24 hour and 6 hour holding periods, the residual solution contains less than 25 ppm and 50 ppm chlorine respectively, flush the piping and tank with potable water, and repeat the above procedures until the required residual chlorine levels are satisfied. The system including the tanks shall then be flushed with clean water until the residual chlorine level is reduced to less than one part per million. During the flushing period each valve and faucet shall be opened and closed several times. Samples of water in disinfected containers shall be obtained from several locations selected by the Contracting Officer.

The samples of water shall be tested for total coliform organisms (coliform bacteria, fecal coliform, streptococcal, and other bacteria) in accordance with AWWA 10084. The testing method used shall be EPA approved for drinking water systems and shall comply with applicable local and state requirements.

Disinfection shall be repeated until tests indicate the absence of coliform organisms (zero mean coliform density per 100 milliliters) in the samples for at least 2 full days. The system will not be accepted until satisfactory bacteriological results have been obtained.

### 3.10 WASTE MANAGEMENT

Place materials defined as hazardous or toxic waste in designated containers. Return solvent and oil soaked rags for contaminant recovery and laundering or for proper disposal. Close and seal tightly partly used sealant and adhesive containers and store in protected, well-ventilated, fire-safe area at moderate temperature. Place used sealant and adhesive tubes and containers in areas designated for hazardous waste. Separate copper and ferrous pipe waste in accordance with the Waste Management Plan and place in designated areas for reuse.

### 3.11 POSTED INSTRUCTIONS

Framed instructions under glass or in laminated plastic, including wiring and control diagrams showing the complete layout of the entire system, shall be posted where directed. Condensed operating instructions explaining preventive maintenance procedures, methods of checking the system for normal safe operation, and procedures for safely starting and stopping the system shall be prepared in typed form, framed as specified above for the wiring and control diagrams and posted beside the diagrams. The framed instructions shall be posted before acceptance testing of the

systems.

3.12 PERFORMANCE OF WATER HEATING EQUIPMENT

Standard rating condition terms are as follows:

EF = Energy factor, minimum overall efficiency.

ET = Minimum thermal efficiency with 70 degrees F delta T.

SL = Standby loss is maximum (Btu/h) based on a 70 degrees F temperature difference between stored water and ambient requirements.

V = Rated volume in gallons

Q = Nameplate input rate in kW (Btu/h)

3.12.1 Storage Water Heaters

3.12.1.1 Electric

- a. Storage capacity of 60 gallons shall have a minimum energy factor (EF) of 0.93 or higher per FEMP requirements.
- b. Storage capacity of 60 gallons or more shall have a minimum energy factor (EF) of 0.91 or higher per FEMP requirements.

3.13 TABLES

TABLE I  
PIPE AND FITTING MATERIALS FOR  
DRAINAGE, WASTE, AND VENT PIPING SYSTEMS

Item #	Pipe and Fitting Materials	SERVICE					
		A	B	C	D	E	F
1	Cast iron soil pipe and fittings, hub and spigot, ASTM A 74 with compression gaskets. Pipe and fittings shall be marked with the CISPI trademark.	X	X	X	X	X	
2	Cast iron soil pipe and fittings hubless, CISPI 301 and ASTM A 888. Pipe and fittings shall be marked with the CISPI trademark.		X	X	X	X	
3	Cast iron drainage fittings, threaded, ASME B16.12 for use with Item 10	X		X	X		
4	Cast iron screwed fittings (threaded) ASME B16.4 for use with Item 10				X	X	

TABLE I  
PIPE AND FITTING MATERIALS FOR  
DRAINAGE, WASTE, AND VENT PIPING SYSTEMS

Item #	Pipe and Fitting Materials	SERVICE					
		A	B	C	D	E	F
5	Grooved pipe couplings, ferrous and non-ferrous pipe ASTM A 536 and ASTM A 47/A 47M	X	X		X	X	
6	Ductile iron grooved joint fittings for ferrous pipe ASTM A 536 and ASTM A 47/A 47M for use with Item 5	X	X		X	X	
7	Bronze sand casting grooved joint pressure fittings for non-ferrous pipe ASTM B 584, for use with Item 5	X	X		X	X	
8	Wrought copper grooved joint pressure fittings for non-ferrous pipe ASTM B 75 C12200, ASTM B 152/B 152M, C11000, ASME B16.22 ASME B16.22 for use with Item 5	X	X				
9	Malleable-iron threaded fittings, galvanized ASME B16.3 for use with Item 10				X	X	
10	Steel pipe, seamless galvanized, ASTM A 53/A 53M, Type S, Grade B	X			X	X	
11	Seamless red brass pipe, ASTM B 43		X	X			
12	Bronzed flanged fittings, ASME B16.24 for use with Items 11 and 14				X	X	
13	Cast copper alloy solder joint pressure fittings, ASME B16.18 for use with Item 14				X	X	
14	Seamless copper pipe, ASTM B 42				X		
15	Cast bronze threaded fittings, ASME B16.15				X	X	
16	Copper drainage tube, (DWV), ASTM B 306	X*	X	X*	X	X	
17	Wrought copper and wrought alloy solder-joint drainage fittings. ASME B16.29	X	X	X	X	X	

TABLE I  
PIPE AND FITTING MATERIALS FOR  
DRAINAGE, WASTE, AND VENT PIPING SYSTEMS

Item #	Pipe and Fitting Materials	SERVICE					
		A	B	C	D	E	F
18	Cast copper alloy solder joint drainage fittings, DWV, ASME B16.23	X	X	X	X	X	
19	Acrylonitrile-Butadiene-Styrene (ABS) plastic drain, waste, and vent pipe and fittings ASTM D 2661, ASTM F 628	X	X	X	X	X	X
20	Polyvinyl Chloride plastic drain, waste and vent pipe and fittings, ASTM D 2665, ASTM F 891, (Sch 40) ASTM F 1760	X	X	X	X	X	X
21	Process glass pipe and fittings, ASTM C 1053						X
22	High-silicon content cast iron pipe and fittings (hub and spigot, and mechanical joint), ASTM A 518/A 518M		X			X	X
23	Polypropylene (PP) waste pipe and fittings, ASTM D 4101						X
24	Filament-wound reinforced thermosetting resin (RTRP) pipe, ASTM D 2996						X

SERVICE:

- A - Underground Building Soil, Waste and Storm Drain
- B - Aboveground Soil, Waste, Drain In Buildings
- C - Underground Vent
- D - Aboveground Vent
- E - Interior Rainwater Conductors Aboveground
- F - Corrosive Waste And Vent Above And Belowground
- \* - Hard Temper

TABLE II  
PIPE AND FITTING MATERIALS FOR PRESSURE PIPING SYSTEMS

Item No.	Pipe and Fitting Materials	SERVICE			
		A	B	C	D
1	Malleable-iron threaded fittings,	X	X	X	X

TABLE II  
PIPE AND FITTING MATERIALS FOR PRESSURE PIPING SYSTEMS

Item No.	Pipe and Fitting Materials	SERVICE			
		A	B	C	D
	a. Galvanized, ASME B16.3 for use with Item 4a				
	b. Same as "a" but not galvanized for use with Item 4b			X	
2	Grooved pipe couplings, ferrous pipe ASTM A 536 and ASTM A 47/A 47M, non-ferrous pipe, ASTM A 536 and ASTM A 47/A 47M,	X	X	X	
3	Ductile iron grooved joint fittings for ferrous pipe ASTM A 536 and ASTM A 47/A 47M, for use with Item 2	X	X	X	
4	Steel pipe:	X	X	X	X
	a. Seamless, galvanized, ASTM A 53/A 53M, Type S, Grade B				
	b. Seamless, black, ASTM A 53/A 53M, Type S, Grade B			X	
5	Seamless red brass pipe, ASTM B 43	X	X		X
6	Bronze flanged fittings, ASME B16.24 for use with Items 5 and 7	X	X		X
7	Seamless copper pipe, ASTM B 42	X	X		X
8	Seamless copper water tube, ASTM B 88, ASTM B 88M	X**	X**	X**	X***
9	Cast bronze threaded fittings, ASME B16.15 for use with Items 5 and 7	X	X		X
10	Wrought copper and bronze solder-joint pressure fittings, ASME B16.22 for use with Items 5, 7 and 8	X	X	X	X
11	Cast copper alloy solder-joint pressure fittings,	X	X	X	X

TABLE II  
PIPE AND FITTING MATERIALS FOR PRESSURE PIPING SYSTEMS

Item No.	Pipe and Fitting Materials	SERVICE			
		A	B	C	D
	ASME B16.18 for use with Item 8				
12	Bronze and sand castings grooved joint pressure fittings for non-ferrous pipe ASTM B 584, for use with Item 2	X	X	X	
13	Polyethylene (PE) plastic pipe, Schedules 40 and 80, based on outside diameter ASTM D 2447	X			X
14	Polyethylene (PE) plastic pipe (SDR-PR), based on controlled outside diameter, ASTM D 3035	X			X
15	Polyethylene (PE) plastic pipe (SIDR-PR), based on controlled inside diameter, ASTM D 2239	X			X
16	Butt fusion polyethylene (PE) plastic pipe fittings, ASTM D 3261 for use with Items 14, 15, and 16	X			X
17	Socket-type polyethylene fittings for outside diameter-controlled polyethylene pipe, ASTM D 2683 for use with Item 15	X			X
18	Polyethylene (PE) plastic tubing, ASTM D 2737	X			X
19	Chlorinated polyvinyl chloride (CPVC) plastic hot and cold water distribution system, ASTM D 2846/D 2846M	X	X		X
20	Chlorinated polyvinyl chloride (CPVC) plastic pipe, Schedule 40 and 80, ASTM F 441/F 441M	X	X		X
21	Chlorinated polyvinyl chloride (CPVC) plastic pipe (SDR-PR) ASTM F 442/F 442M	X	X		X

TABLE II  
PIPE AND FITTING MATERIALS FOR PRESSURE PIPING SYSTEMS

Item No.	Pipe and Fitting Materials	SERVICE			
		A	B	C	D
22	Threaded chlorinated polyvinyl chloride (chloride CPVC) plastic pipe fittings, Schedule 80, ASTM F 437, for use with Items 20, and 21	X	X		X
23	Socket-type chlorinated polyvinyl chloride (CPVC) plastic pipe fittings, Schedule 40, ASTM F 438 for use with Items 20, 21, and 22	X	X		X
24	Socket-type chlorinated polyvinyl chloride (CPVC) plastic pipe fittings Schedule 80, ASTM F 439 for use with Items 20, 21, and 22	X	X		X
25	Polyvinyl chloride (PVC) plastic pipe, Schedules 40, 80, and 120, ASTM D 1785	X			X
26	Polyvinyl chloride (PVC) pressure-rated pipe (SDR Series), ASTM D 2241	X			X
27	Polyvinyl chloride (PVC) plastic pipe fittings, Schedule 40, ASTM D 2466	X			X
28	Socket-type polyvinyl chloride (PVC) plastic pipe fittings, schedule 80, ASTM D 2467 for use with Items 26 and 27	X			X
29	Threaded polyvinyl chloride (PVC) plastic pipe fittings, schedule 80, ASTM D 2464	X			X
30	Joints for IPS pvs pipe using solvent cement, ASTM D 2672	X			X
31	Filament-wound reinforced thermosetting resin (RTRP) pipe, ASTM D 2996	X	X		
32	Steel pipeline flanges, MSS SP-44	X	X		
33	Fittings: brass or bronze; ASME B16.15, and	X	X		

TABLE II  
PIPE AND FITTING MATERIALS FOR PRESSURE PIPING SYSTEMS

Item No.	Pipe and Fitting Materials	SERVICE			
		A	B	C	D
	ASME B16.18 ASTM B 828				
34	Carbon steel pipe unions, socket-welding and threaded, MSS SP-83	X	X	X	
35	Malleable-iron threaded pipe unions ASME B16.39	X	X		
36	Nipples, pipe threaded ASTM A 733	X	X	X	
37	Crosslinked Polyethylene (PEX) Plastic Pipe ASTM F 877.	X	X		X
38	Press Fittings	X	X		

A - Cold Water Service Aboveground

B - Hot and Cold Water Distribution 180 degrees F Maximum Aboveground

C - Compressed Air Lubricated

D - Cold Water Service Belowground

Indicated types are minimum wall thicknesses.

\*\* - Type L - Hard

\*\*\* - Type K - Hard temper with brazed joints only or type K-soft temper  
without joints in or under floors

\*\*\*\* - In or under slab floors only brazed joints

TABLE III  
STANDARD RATING CONDITIONS AND MINIMUM PERFORMANCE RATINGS FOR WATER HEATING  
EQUIPMENT (I-P)

A. STORAGE WATER HEATERS

FUEL	STORAGE CAPACITY GALLONS	INPUT RATING	TEST PROCEDURE	REQUIRED PERFORMANCE
Elect.	60 max.		10 CFR 430	EF = 0.93
Elect.	60 min.		10 CFR 430	EF = 0.91
Elect.	20 min.	12 kW max.	10 CFR 430	EF = 0.93-0.00132V min.
Elect.	20 min.	12 kW min.	CSA/AM Z21.10.3	SL = 20+35x(V <sup>1/2</sup> )max.

TERMS:

TABLE III  
 STANDARD RATING CONDITIONS AND MINIMUM PERFORMANCE RATINGS FOR WATER HEATING  
 EQUIPMENT (I-P)

A. STORAGE WATER HEATERS

FUEL	STORAGE CAPACITY GALLONS	INPUT RATING	TEST PROCEDURE	REQUIRED PERFORMANCE
------	--------------------------------	-----------------	----------------	-------------------------

EF = Energy factor, minimum overall efficiency.

ET = Minimum thermal efficiency with 70 degrees F delta T.

SL = Standby loss is maximum Btu/h based on a 70 degree F temperature difference between stored water and ambient requirements.

V = Rated storage volume in gallons

Q = Nameplate input rate in Btu/h

-- End of Section --

# ELKAY<sup>®</sup>

## SPECIFICATIONS

### Pacemaker<sup>®</sup> Double Bowl Sink 20 Gauge - Type 304 - Self-Rim Model PSR Series

#### GENERAL

Fine quality Pacemaker double bowl hospitality sink seamlessly drawn of #20 gauge, type 304 (18-8) nickel bearing stainless steel. Self-rimming.

#### DESIGN FEATURES

Bowl Depths: 7-1/4" (PSR3319 and PSR4322), 7-1/2" (PSR3321).

Coved Corners: 1-3/4".

Bowl and Faucet Deck Recess: 3/16" drop ledge.

Finish: Exposed surfaces are polished to a lustrous, highlighted bright satin finish.

Underside: Fully undercoated to prevent condensation and deaden sound. PSR3321 underside is fully protected by heavy duty Sound Guard<sup>®</sup> undercoating.

#### OTHER

Drain Openings: 3-1/2".

Faucet Holes: Available with 0, 1, 2, MR2, 3, 4 or 5, 1-1/2" diameter faucet holes 4" centers.

NOTE: Unless otherwise specified, sink is furnished with 4 faucet holes.

These sinks comply with ANSI Standard A112.19.3M.



These sinks are listed by the International Association of Plumbers and Mechanical Officials as meeting the requirements of the Uniform Plumbing Code.

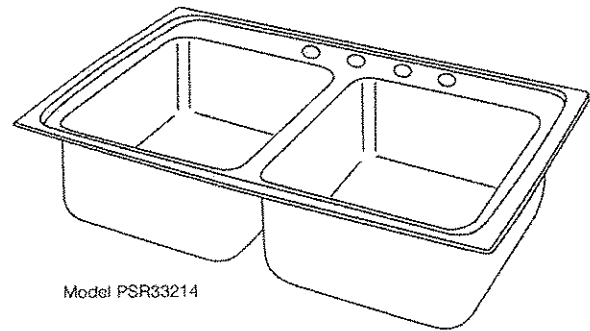

Model PSR33214

#### SINK DIMENSIONS (INCHES)\*

Model Number	Overall		Inside Each Bowl			Cutout in Countertop (1 1/2" Radius Corners)		No. of 1 1/2" Dia. Faucet Holes 4" Center	Minimum Cabinet Size	Ship. Wt. Lbs.
	L	W	L	W	D	L	W			
PSR3319	33	19 1/2	14	14	7 1/4	32 3/8	18 7/8	1, 2, MR2, 3, 4 or 5	36	16
PSR3321	33	21 1/4	13 1/2	16	7 1/2	32 3/8	20 3/8	1, 2, MR2, 3, 4 or 5	36	17
PSR4322	43	22	19	16	7 1/4	42 3/8	21 3/8	1, 2, MR2, 3, 4 or 5	48	20

\*Length is left to right. Width is front to back.

#### HOLE DRILLING CONFIGURATIONS

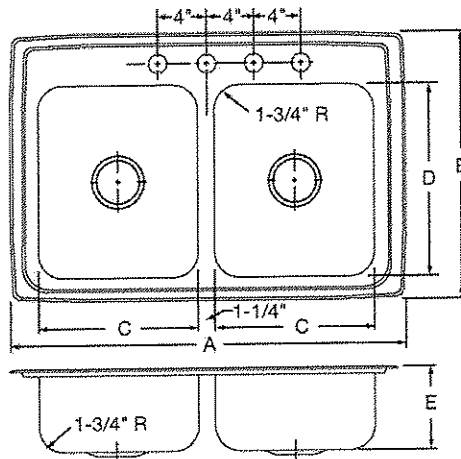
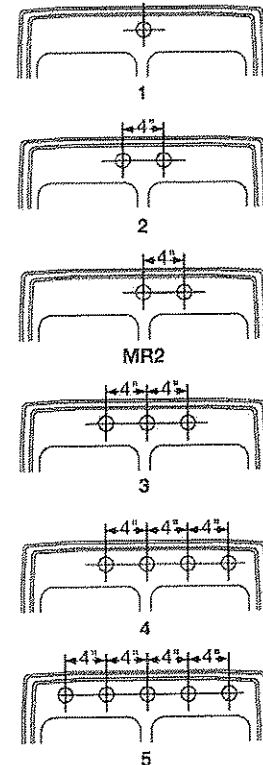

Model PSR33214 Illustrated

ALL DIMENSIONS IN INCHES. TO CONVERT TO MILLIMETERS MULTIPLY BY 25.4.

In keeping with our policy of continuing product improvement, Elkay reserves the right to change product specifications without notice.

This specification describes an Elkay product with design, quality and functional benefits to the user. When making a comparison of other producers' offerings, be certain these features are not overlooked.

Elkay

www.elkayusa.com

2222 Camden Court  
Oak Brook, IL 60523

Printed in U.S.A.  
©2003 Elkay

(Rev. 10/03) 1-75D

► **Description**  
Exposed, Battery Powered, Sensor Activated, Sloan® Optima® SMOOTH™ Water Closet Flushometer for floor mounted or wall hung top spud bowls.

► **Flush Cycle**  
 Model 110 Water Saver (3.5 gpf/13.2 Lpf)  
 Model 111 Low Consumption (1.6 gpf/6.0 Lpf)

► **Specifications**  
Quiet, Exposed, Diaphragm Type, Chrome Plated Closet Flushometer with the following features:

**Flushometer**

- High Chloramine Resistant PERMEX™ Synthetic Rubber Diaphragm with Linear Filtered Bypass and Vortex Cleansing Action™
- ADA Compliant Metal Oscillating Non-Hold-Open Handle with Triple Seal Handle Packing
- 1" I.P.S. Screwdriver Bak-Chek™ Angle Stop
- Vandal Resistant Stop Cap
- Adjustable Tailpiece
- Vacuum Breaker with Flush Connection
- Spud Coupling and Spud Flange for 1½" Top Spud
- Sweat Solder Adapter with Cover Tube and Cast Wall Flange
- High Copper, Low Zinc Brass Castings for Dezincification Resistance
- Non-Hold-Open Handle and No External Volume Adjustment to Ensure Water Conservation
- Low Consumption flush accuracy
- Handle Packing, Stop Seat and Vacuum Breaker Molded from PERMEX™ Rubber Compound for Chloramine Resistance

**Optima SMOOTH Unit**

- ADA Compliant OPTIMA® SMOOTH™ Battery Powered Infrared Sensor for automatic "Hands-free" operation
- Sensor with Automatic Range Adjustment
- Chrome Plated Metal Sensor Housing
- Mechanical Manual Override Flush Handle
- Four (4) Size C Batteries included
- "Low Battery" Flashing LED
- "User in View" Flashing LED
- 25 to 80 psi Operating Range

Valve Body, Cover, Tailpiece and Control Stop shall be in conformance with ASTM Alloy Classification for Semi-Red Brass. Valve shall be in compliance to the applicable sections of ASSE 1037, ANSI/ASME A 12.19.2, and Military Specification V-29193.

► **Variations**

- TP Trap Primer
- DFB Dual Filtered Fixed Bypass Diaphragm
- YG Extended Bumper on Angle Stop (for seat with cover)



This space for Architect/Engineer approval	
Job Name _____	Date _____
Model Specified _____	Quantity _____
Variations Specified _____	
Customer/Wholesaler _____	
Contractor _____	
Architect _____	

The information contained in this document is subject to change without notice.



► **ADA Compliant**

► **Automatic**

Sloan SMOOTH™ equipped Flushometers provide the ultimate in sanitary protection and automatic operation. There is no need for AC hookups or wall alterations. The Flushometer operates by means of a battery powered infrared sensor. Once the user enters the sensor's effective range and then steps away, the SMOOTH™ Unit initiates the flushing cycle to flush the fixture. State-of-the-art Technology enables activation of a manual override without "double flushing" occurring as the user departs (locks out sensor for approximately 10 seconds).

► **Hygienic**

The Sloan® Optima® SMOOTH™ Flushometer is the next advancement in hygiene. It uses sensor technology to transform manual installations into electronic, hands-free operation. User makes no physical contact with the Flushometer surface except to initiate the Override Handle when required. Helps control the spread of infectious diseases.

► **Economical**

Automatic operation provides water usage savings over other flushing devices. Reduces maintenance and operation costs. Installation and battery replacement does not require turning off water to the valve.

► **Warranty**

3 year (limited)

## Model

# 110/111

### ► Description

Exposed, Battery Powered, Sensor Activated, Sloan® Optima® SMOOTH™ Water Closet Flushometer for floor mounted or wall hung top spud bowls.

### ► Flush Cycle

- Model 110 Water Saver (3.5 gpf/13.2 Lpf)
- Model 111 Low Consumption (1.6 gpf/6.0 Lpf)

## ELECTRICAL SPECIFICATIONS

- |   |  |
|---|--|
| ► <b>Control Circuit</b><br>6 VDC Input   | ► <b>Battery Type</b><br>(4) Size C Alkaline           |
| ► <b>OPTIMA Sensor Type</b><br>Active Infrared with Automatic Adjustment  | ► <b>Battery Life</b><br>2 Years @ 4,000 Flushes/Month |
| ► <b>OPTIMA Sensor Range</b><br>Normal Range:<br>26" - 32" (660 mm-813 mm)<br>Reduced Range:<br>20" - 26" (508 mm-660 mm) | ► <b>Indicator Lights</b><br>User in View/Low Battery  |
|   | ► <b>Operating Pressure</b><br>25-80 psi (172-552 kPa) |

## OPERATION

1. A continuous, invisible light beam is emitted from the SMOOTH unit's Infrared Sensor.
2. When the user enters the sensor's effective range, the Red LED light in the sensor window flashes for eight seconds. After eight seconds of sensing the user, the light will stop flashing and the unit waits for the user to step away before initiating a flush cycle.
3. When the user steps away, the unit initiates a flush cycle. The unit then automatically resets and is ready for the next user.

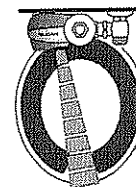
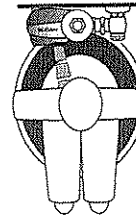

## DIMENSIONS

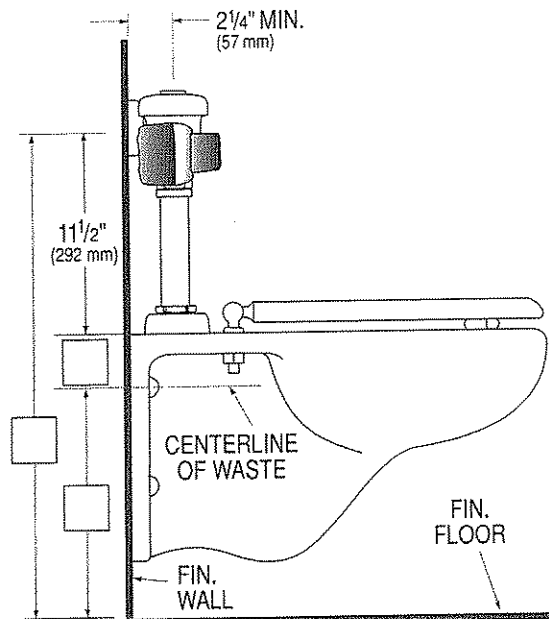

Side View

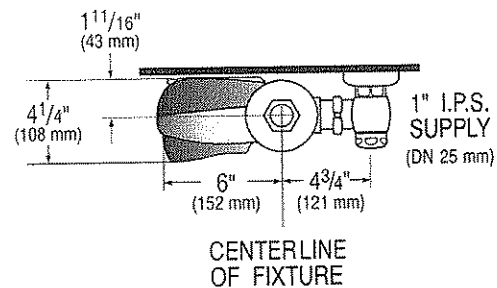

Top View

**SLOAN VALVE COMPANY • 10500 SEYMOUR AVENUE • FRANKLIN PARK, IL 60131**

Phone: 1-800-9-VALVE-9 or 1-847-671-4300 • Fax: 1-800-447-8329 or 1-847-671-4380 • [www.sloanvalve.com](http://www.sloanvalve.com)

► **Description**  
Exposed, Battery Powered, Sensor Activated, Sloan® Optima® SMOOTH™ Urinal Flushometer for 3/4" top spud urinals.

- **Flush Cycle**
- Model 186 Water Saver (1.5 gpf/5.7 Lpf)
  - Model 186-1.0 Low Consumption (1.0 gpf/3.8 Lpf)
  - Model 186-0.5 (0.5 gpf/1.9 Lpf)

► **Specifications**  
Quiet, Exposed, Diaphragm Type, Chrome Plated Urinal Flushometer with the following features:

**Flushometer**

- High Chloramine Resistant PERMEX™ Synthetic Rubber Diaphragm with Linear Filtered Bypass and Vortex Cleansing Action™
- ADA Compliant Metal Oscillating Non-Hold-Open Handle with Triple Seal Handle Packing
- 3/4" I.P.S. Screwdriver Bak-Chek™ Angle Stop
- Vandal Resistant Stop Cap
- Adjustable Tailpiece
- Vacuum Breaker with Flush Connection
- Spud Coupling and Spud Flange for 3/4" Top Spud
- Sweat Solder Adapter with Cover Tube and Cast Wall Flange
- High Copper, Low Zinc Brass Castings for Dezincification Resistance
- Non-Hold-Open Handle and No External Volume Adjustment to Ensure Water Conservation
- Low Consumption flush accuracy
- Handle Packing, Stop Seat and Vacuum Breaker Molded from PERMEX™ Rubber Compound for Chloramine Resistance

**Optima SMOOTH Unit**

- ADA Compliant OPTIMA® SMOOTH™ Battery Powered Infrared Sensor for automatic "Hands-free" operation
- Sensor with Automatic Range Adjustment
- Chrome Plated Metal Sensor Housing
- Mechanical Manual Override Flush Handle
- Four (4) Size C Batteries included
- "Low Battery" Flashing LED
- "User in View" Flashing LED
- 25 to 80 psi Operating Range

Valve Body, Cover, Tailpiece and Control Stop shall be in conformance with ASTM Alloy Classification for Semi-Red Brass. Valve shall be in compliance to the applicable sections of ASSE 1037, ANSI/ASME A112.19.2, and Military Specification V-29193.

► **Variations**

- DFB Dual Filtered Fixed Bypass Diaphragm



This space for Architect/Engineer approval	
Job Name _____	Date _____
Model Specified _____	Quantity _____
Variations Specified _____	
Customer/Wholesaler _____	
Contractor _____	
Architect _____	

The information contained in this document is subject to change without notice.



► **ADA Compliant**

► **Automatic**

Sloan SMOOTH™ equipped Flushometers provide the ultimate in sanitary protection and automatic operation. There is no need for AC hookups or wall alterations. The Flushometer operates by means of a battery powered infrared sensor. Once the user enters the sensor's effective range and then steps away, the SMOOTH™ Unit initiates the flushing cycle to flush the fixture. State-of-the-art Technology enables activation of a manual override without "double flushing" occurring as the user departs (locks out sensor for approximately 10 seconds).

► **Hygienic**

The Sloan® Optima® SMOOTH™ Flushometer is the next advancement in hygiene. It uses sensor technology to transform manual installations into electronic, hands-free operation. User makes no physical contact with the Flushometer surface except to initiate the Override Handle when required. Helps control the spread of infectious diseases.

► **Economical**

Automatic operation provides water usage savings over other flushing devices. Reduces maintenance and operation costs. Installation and battery replacement does not require turning off water to the valve.

► **Warranty**

3 year (limited)

# Model 186

## ► Description

Exposed, Battery Powered, Sensor Activated, Sloan® Optima® SMOOTH™ Urinal Flushometer for ¾" top spud urinals.

## ► Flush Cycle

- Model 186 Water Saver (1.5 gpf/5.7 Lpf)
- Model 186-1.0 Low Consumption (1.0 gpf/3.8 Lpf)
- Model 186-0.5 (0.5 gpf/1.9 Lpf)

## ELECTRICAL SPECIFICATIONS

- |   |  |
|---|--|
| ► <b>Control Circuit</b><br>6 VDC Input   | ► <b>Battery Type</b><br>(4) Size C Alkaline           |
| ► <b>OPTIMA Sensor Type</b><br>Active Infrared with Automatic Adjustment  | ► <b>Battery Life</b><br>2 Years @ 4,000 Flushes/Month |
| ► <b>OPTIMA Sensor Range</b><br>Normal Range:<br>26" - 32" (660 mm-813 mm)<br>Reduced Range:<br>20" - 26" (508 mm-660 mm) | ► <b>Indicator Lights</b><br>User in View/Low Battery  |
|   | ► <b>Operating Pressure</b><br>25-80 psi (172-552 kPa) |

## OPERATION

1. A continuous, invisible light beam is emitted from the SMOOTH unit's Infrared Sensor.
2. When the user enters the sensor's effective range, the Red LED light in the sensor window flashes for eight seconds. After eight seconds of sensing the user, the light will stop flashing and the unit waits for the user to step away before initiating a flush cycle.
3. When the user steps away, the unit initiates a flush cycle. The unit then automatically resets and is ready for the next user.

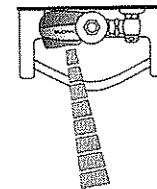
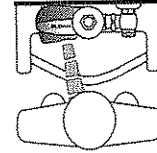
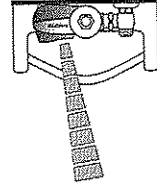

## DIMENSIONS

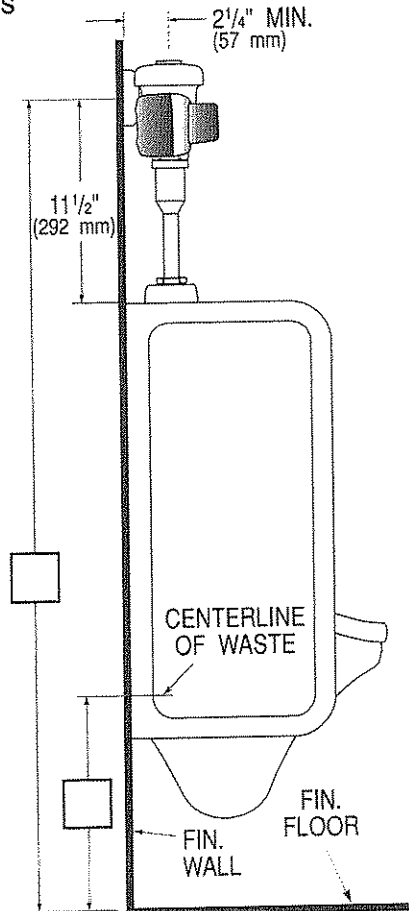

Side View

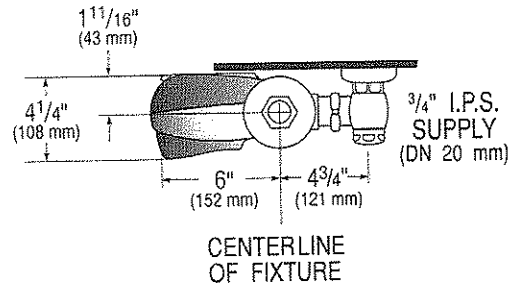

Top View

**SLOAN VALVE COMPANY • 10500 SEYMOUR AVENUE • FRANKLIN PARK, IL 60131**  
 Phone: 1-800-9-VALVE-9 or 1-847-671-4300 • Fax: 1-800-447-8329 or 1-847-671-4380 • [www.sloanvalve.com](http://www.sloanvalve.com)

# SLOAN® Faucets

## Sensor Activated Electronic Handwashing Faucet

# SF-2300 SF-2350 ←

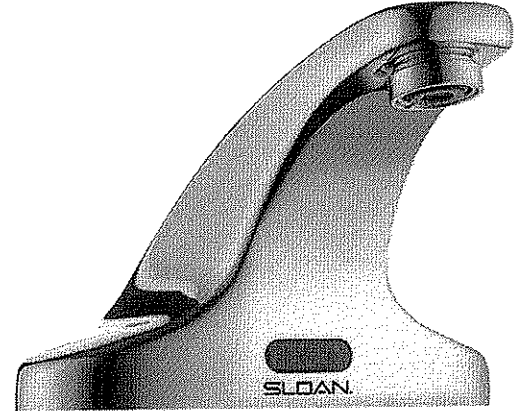

- ▶ **Description**  
Sensor Activated, Electronic, 4 inch Centerset Hand Washing Faucet for tempered or hot/cold water operation.
- ▶ **Models**
  - SF-2300 Series 6 VDC Plug-in Transformer Powered with Battery Backup
  - SF-2350 Series Battery Powered
- ▶ **Flow Rate**
  - 0.5 gpm/1.9 Lpm Max Flow Spray Head
- ▶ **Specifications**  
ADA Compliant, Sensor Activated, 6 VDC, Chrome Plated Brass, Hand Washing Faucet with the following features:
  - Splash-proof Circuit Control Module
  - Adjustable Infrared Sensor Range
  - 36" (914 mm) Long Sensor Cable
  - 24" (610 mm) Long Flex Hose
  - Filtered Solenoid Valve with serviceable Strainer Filter
  - Bak-Chek™ Tee for Hot/Cold Supply
  - 6 VDC Plug-in Transformer (Model SF-2300 only)
  - Aerator Spray Head
  - Includes Four (4) AA-size Batteries
  - Includes appropriate Mounting Hardware
- ▶ **Variations (add suffix to Model Number for inclusion with Faucet)**
  - **Temperature Mixing Valves**
    - BDM MIX-60-A Below Deck Mechanical Mixing Valve
- ▶ **Accessories (specify separately)**
  - **Standard Outlet**
    - SFP-13 0.5 gpm/1.9 Lpm Spray Head
    - SFP-23 2.2 gpm/8.3 Lpm Aerator
  - **Vandal Resistant Outlet**
    - EAF-15 0.5 gpm/1.9 Lpm Vandal Resistant Spray Head
    - SFP-24 2.2 gpm/8.3 Lpm Vandal Resistant Aerator
  - **Transformers**
    - SFP-6 120 VAC/6 VDC Plug-in Transformer
    - SFP-20 240 VAC/6 VDC Type G Rectangular (UK) Plug-in Transformer
    - SFP-25 240 VAC/6 VDC Type C Round Pin (Euro) Plug-in Transformer
    - SFP-26 240 VAC/6 VDC Type A Flat Blade (Asia) Plug-in Transformer
    - SFP-35-A Gang Transformer Kit, includes 1 Plug-in Gang Transformer, 5 Splitter Cables and 1 Extension Cable
    - SFP-36 71" (1800 mm) 120 VAC/6 VDC Plug-in Gang Transformer
    - SFP-38 51" (1300 mm) Splitter Cable
    - SFP-37 51" (1300 mm) Extension Cable

- ▶ **ADA Compliant**
- ▶ **Automatic**  
The Sloan SF-2300 and SF-2350 Electronic Hand Washing Faucets operate by means of an infrared sensor. When the user enters the sensor's effective range, the Solenoid activates the water flow. Tempered water flows from the Faucet until the user steps away. The Faucet then automatically shuts off.
- ▶ **Hygienic**  
The ultimate in sanitary protection — there are no handles to turn or buttons to push. Helps to control the spread of infectious diseases.
- ▶ **Economical**  
Automatic operation provides water usage savings over other faucet devices. Reduces maintenance and operation costs.
- ▶ **Warranty**  
1 year (limited)
- ▶ **Compliant to:**  
ASME A112.18.1 and CSA B125.1



Listed by I.A.P.M.O.



Certified



This space for Architect/Engineer approval	
Job Name .....	Date .....
Model Specified .....	Quantity .....
Variations Specified .....	
Customer/Wholesaler .....	
Contractor .....	
Architect .....	

# SF-2300 SF-2350

- ▶ **Description**  
Sensor Activated, Electronic, 4 inch Centerset Hand Washing Faucet for tempered or hot/cold water operation.
- ▶ **Models**
  - SF-2300 Series 6 VDC Plug-in Transformer Powered with Battery Backup
  - SF-2350 Series Battery Powered
- ▶ **Flow Rate**  
□ 0.5 gpm/1.9 Lpm Max Flow Spray Head

## ELECTRICAL SPECIFICATIONS

- ▶ **Control Circuit**  
6 VDC Input/Output
- ▶ **Transformer**  
6 VDC Plug-in (Model 2300 only)
- ▶ **Battery Life**  
Four (4) Alkaline AA Batteries  
2 years at 8,000 cycles/month
- ▶ **Solenoid Valve**  
6 VDC,  
Serviceable Strainer,  
3/8" Compression Inlet,  
1/2" NPSM Outlet
- ▶ **Sensor Range**  
Nominal:  
4" - 7" (102 mm - 178 mm)

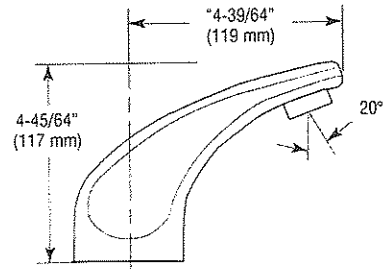

## OPERATION

1. When a user's hands enter the sensing range, water flows from the spout.

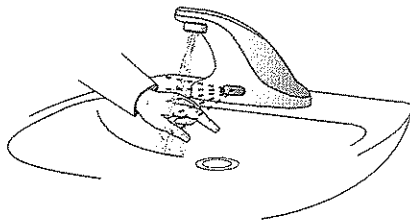

2. When hands are removed, the water flow stops.

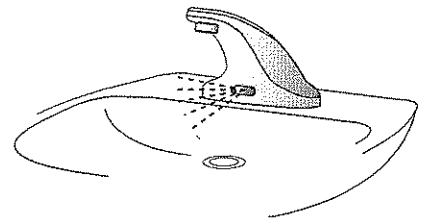

## ROUGH-IN DIMENSIONS

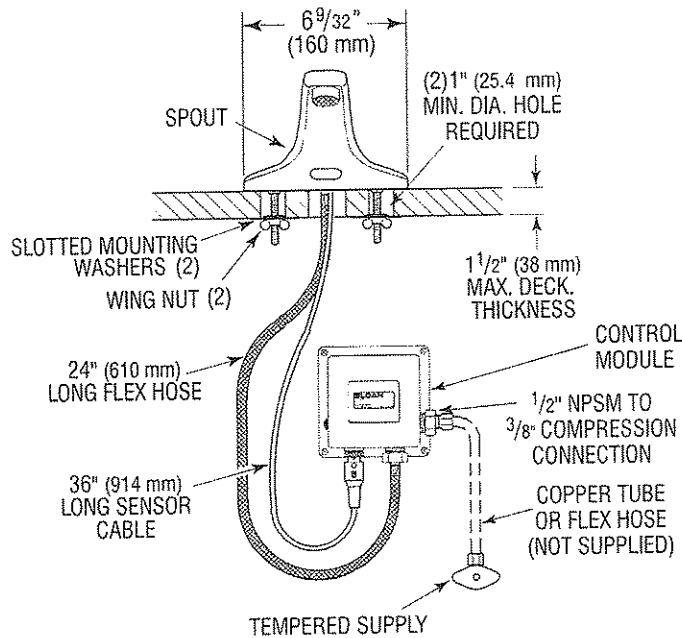

## HOT AND COLD WATER SUPPLY APPLICATIONS (SPECIFY IN MODEL VARIATION)

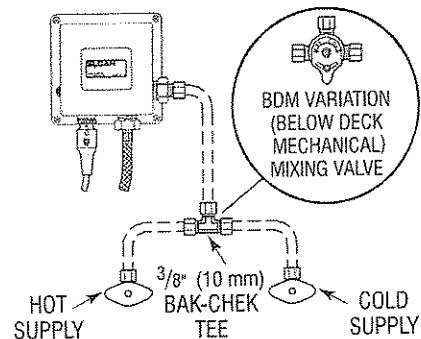

**SLOAN VALVE COMPANY • 10500 SEYMOUR AVENUE • FRANKLIN PARK, IL 60131**  
 Phone: 1-800-982-5839 or 1-847-671-4300 • Fax: 1-800-447-8329 or 1-847-671-4380 • [www.sloanvalve.com](http://www.sloanvalve.com)

# ELKAY<sup>®</sup>

## SPECIFICATIONS

### Two Station Wall Mount Water Coolers Barrier-Free Access (Adult and Child) NSF/ANSI 61 Compliant – Models EZTL8C, EZSTL8C, EZTLDDC and EZSTLDDC

#### GENERAL

Self-contained, wall hung electric refrigerated water cooler. Chilling capacity of 50°F drinking water, based upon 80°F inlet water and 90°F ambient.

**Model EZSTL8C** has self-closing Easy-Touch Controls on front, left and right of each unit.

**Model EZTL8C** has self-closing Easy-Touch Controls on the front of each unit.

**Model EZSTLDDC** non-refrigerated. Same as EZSTL8C without cooling system. (Requires outlet for power cord.)

All models have a hooded stream projector with Easy-Touch Controls that require less than 3 pounds of force to activate commercial-grade solenoid based flow control. Patented\* valve with built-in flow regulator provide constant stream from 20 to 105 psi water pressure. Bubbler orifice fully protected to meet all sanitary codes.

**NOTE:** Minimum 40 psi supply line pressure required in special circumstances where both sides of bi-level are in use simultaneously to ensure adequate stream height. Does not apply to non-refrigerated units.

This model cooler consists of a refrigerated lower unit which requires a water supply, drain outlet and electrical supply.

#### ADA COMPLIANT

These Water Coolers comply with the requirements of A.D.A. (Americans with Disabilities Act) when properly installed. Unit is compliant if installed in an alcove and is also compliant when mounted on an exposed wall if a wing wall is located on the left side or if LKAPREZL apron is installed under upper unit. Also meets the guidelines for children's environments providing the floor to orifice height is 30" or less on the lower unit and proper clear floor space is provided for parallel approach. (Based on Architectural and Transportation Barriers Compliance Board final ruling.) Check Local and State Codes.

#### NO LEAD DESIGN

These Water Coolers are certified to be lead-free as defined by the Safe Drinking Water Act. Elkay Water Coolers are manufactured with a waterway system utilizing copper components and completely lead-free materials. These waterways have no lead because all lead materials, such as leaded brass, have been removed. All joints are brazed using silver solder only. No lead solder is permitted. A strainer with an easily cleanable screen is provided to allow trapping and convenient removal of waterborne particulate of 140 microns and larger prior to their entry into the water cooler.

These water coolers are certified to NSF/ANSI 61.

#### CAPACITIES CHART

Model Number	Base Rate	**GPH of 50°F Drinking Water			Rated Watts	Full Load Amps	Glass Filler Option	Ship. Wt. Lbs.
		Room Temperature °F						
		70°F	80°F	90°F				
EZSTL8C	8.0	9.7	8.8	8.0	370	4.0	Yes	89
EZTL8C	8.0	9.7	8.8	8.0	370	4.0	Yes	89
EZTLDDC	–	–	–	–	–	–	Yes	66
EZSTLDDC	–	–	–	–	–	–	Yes	66

\*\*Based on 80°F inlet water temperature. †Glass filler available at extra cost. Requires factory preparation to receive glass filler. Upper unit only.

Rated watts shown are based on operational (run) time, in compliance with A.R.I. Standard 1010 conditions. Specific applications will determine the actual watts consumed per hour. Watts consumed will be based on number of people served per hour (usage), ambient temperatures, and inlet water temperature.

#### COOLING SYSTEM

**Motor Compressor:** Hermetically sealed, reciprocating type, 115VAC, 60Hz single phase. Sealed-in lifetime oil supply. Equipped with electric cord and three prong molded rubber plug (domestic models).

*In keeping with our policy of continuing product improvement, Elkay reserves the right to change product specifications without notice.*

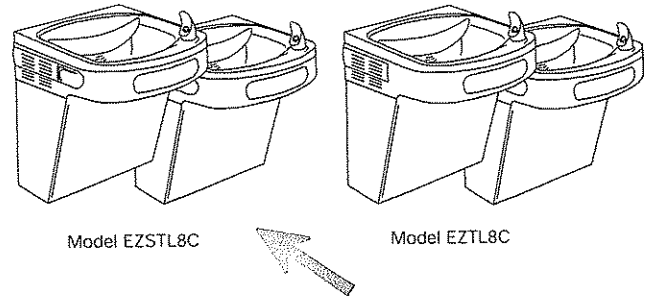

**Condenser:** Fan cooled, copper tube with aluminum fins. Fan motor is permanently lubricated.

**Cooling Unit:** Combination tube-tank type. Tube portion is continuous coil of copper tubing. Tank is stainless steel. Fully insulated with EPS foam which meets Underwriters Laboratories Inc. requirements for self-extinguishing material.

**Refrigerant Control:** Refrigerant HFC-134a is controlled by accurately calibrated capillary tube for positively trouble-free operation.

**Temperature Control:** Enclosed adjustable thermostat is factory preset. Requires no adjustment other than for altitude requirements. Easily accessible.

#### CONSTRUCTION

**Frame:** Galvanized structural steel chassis supports refrigeration system and fastens to wall. Provides increased structural integrity and rigidity to cooler.

**Stainless Steel Basin:** Type 304, one piece polished to a uniform Elkay bright luster finish. Basin has integral drain grid, embossed bubbler pad. No exposed fasteners.

**Exclusive Flexi-Guard® Safety Bubbler\*:** Innovative design utilizes an infused anti-microbial pliable polyester elastomer to prevent accidental mouth injuries. Flexes on impact, then returns to original position. Strong. Abrasion-resistant. Anti-sweat. Keyed in location to prevent rotation.

**Upper Shroud:** Contoured shock-absorbing, provides additional protection against accidental injury. No exposed fasteners.

**Lower Shroud:** One piece easy to remove and replace. Allows access to internal components from three sides.

**Cabinet:** Cabinet design allows for flush to wall mounting. No recess space is required.

**Color Selection:** Unless otherwise specified cabinet is two-tone gray upper shroud with textured gray lower shroud. Stainless Steel lower shrouds available at extra cost.

**5 YEAR LIMITED WARRANTY** on the refrigeration system of the unit. Electrical components and water system are warranted for 12 months from date of installation. Sample Certificate available on request.

Elkay Pressure-Type Water Coolers are designed to operate on 20 psi to 105 psi supply line pressure. If inlet pressure is above 105 psi, a pressure regulator must be installed in the supply line. Any damage caused by reason of connecting this product to supply line pressures lower than 20 psi or higher than 105 psi is not covered by the warranty.

#### STANDARDS



Elkay Electric Air Cooled Water Coolers meet the requirements of NSF/ANSI 61. Unit complies with A.R.I. Standard 1010.

\* Patent #4,481,971

*This specification describes an Elkay product with design, quality and functional benefits to the user. When making a comparison of other producers' offerings, be certain these features are not overlooked.*

**Two Station Wall Mount Water Coolers  
Barrier-Free Access (Adult and Child)  
NSF/ANSI 61 Compliant – Models EZTL8C,  
EZSTL8C, EZTLDDC and EZSTLDDC**

**ELKAY®  
ROUGH-IN DIMENSIONS**

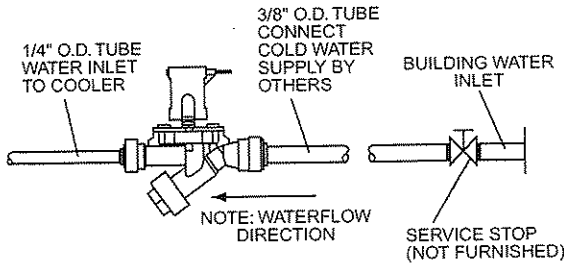

**IMPORTANT!  
INSTALLER PLEASE NOTE:**

This water cooler has been designed and built to provide water to the user which has not been altered by materials in the cooler waterways.

The grounding of electrical equipment such as telephone, computers, etc., to water lines is a common procedure. This grounding may be in the building but may also occur away from the building. This grounding can cause electrical feedback into a water cooler creating an electrolysis which creates a metallic taste or causes an increase in the metal content of the water. This condition is avoidable by installing the cooler using the proper materials as shown below.

**NOTICE**

This water cooler must be connected to the water supply using a dielectric coupling. The cooler is furnished with a non-metallic strainer which meets this requirement. The drain trap which is provided by the installer should also be plastic to completely isolate the cooler from the building plumbing system.

**OPERATION OF QUICK CONNECT FITTINGS**

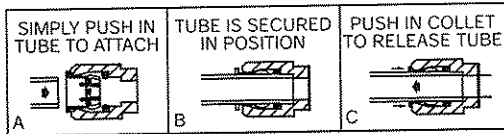

PUSHING TUBE IN BEFORE PULLING IT OUT HELPS TO RELEASE TUBE

**FRONT VIEW**

**SIDE VIEW**

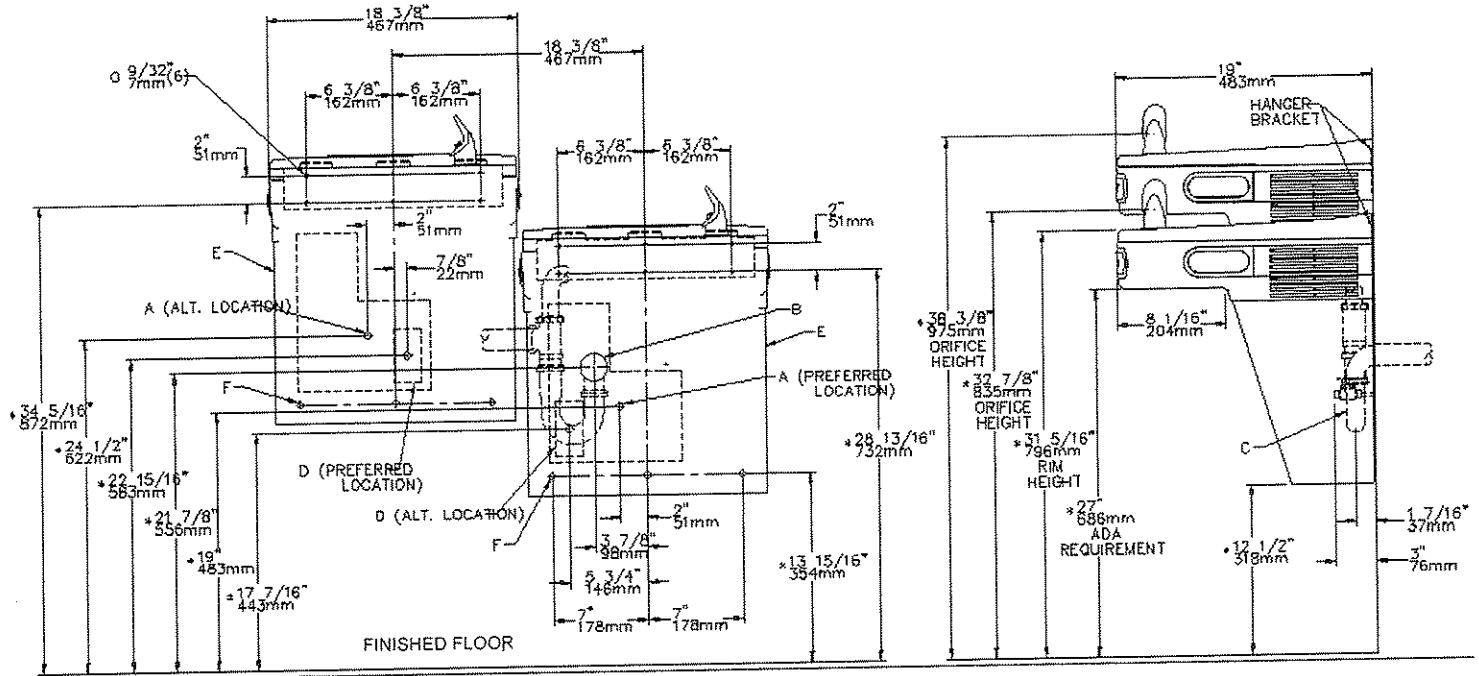

\*REDUCE HEIGHT BY 3 INCHES FOR INSTALLATION OF CHILDREN'S ADA COOLER

**LEGEND**

- A = RECOMMENDED WATER SUPPLY LOCATION 3/8 O.D. UNPLATED COPPER TUBE CONNECT STUB WITH SHUT OFF (BY OTHERS) 3 IN. (76mm) MAXIMUM OUT FROM WALL
- B = RECOMMENDED LOCATION FOR WASTE OUTLET TO ACCOMODATE 1-1/2" NOMINAL DRAIN. DRAIN STUB 2 IN. OUT FROM WALL
- C = 1-1/2 TRAP NOT FURNISHED
- D = ELECTRICAL SUPPLY (3) WIRE RECESSED BOX DUPLEX OUTLET
- F = 7/16 BOLT HOLES FOR FASTENING UNIT TO WALL

INSURE PROPER VENTILATION BY MAINTAINING 6" (152mm) MINIMUM CLEARANCE FROM CABINET LOUVERS TO WALL.

# ELKAY<sup>®</sup>

## SPECIFICATIONS

### Wall Mount Water Coolers Barrier-Free Access (Adult & Child) NSF/ANSI 61 Compliant Models EZ4, EZ8, EZS4, EZS8, EZSD and EZD

#### GENERAL

Self-contained, wall hung electric refrigerated water cooler. Chilling capacity of 50°F drinking water, based upon 80°F inlet water and 90°F ambient.

Models **EZS4** and **EZS8** have self-closing Easy-Touch Controls on front and both right and left sides.

Models **EZ4** and **EZ8** each have self-closing Easy-Touch Controls on the front only.

Model **EZSD** is non-refrigerated. Same as **EZS8** without cooling system. (Requires outlet for power cord.)

All models have a hooded stream projector with Easy-Touch Controls that require less than 3 pounds of force to activate. Patented\* valve with built-in flow regulator provide constant stream from 20 to 105 psi, water pressure. Bubbler orifice fully protected to meet all sanitary codes.

Non-pressurized stainless steel cooling tank is standard. Non-pressurized water tank is located after bubbler valve, so that tank is subject to line pressure only when Easy-Touch Control is pressed.

#### ADA COMPLIANT

These Water Coolers comply with the requirements of A.D.A. (Americans with Disabilities Act) when properly installed. Also meets the guidelines for children's environments providing the floor to orifice height is 30" or less and proper clear floor space is provided for parallel approach. (Based on Architectural and Transportation Barriers Compliance Board final ruling.) Check Local and State Codes.

#### NO LEAD DESIGN

These Water Coolers are certified to be lead-free as defined by the Safe Drinking Water Act. Elkay Water Coolers are manufactured with a waterway system utilizing copper components and completely lead-free materials. These waterways have no lead because all lead materials, such as leaded brass, have been removed. All joints are brazed using silver solder only. No lead solder is permitted. A strainer with an easily cleanable screen is provided to allow trapping and convenient removal of waterborne particulate of 140 microns and larger prior to their entry into the water cooler.

These water coolers are certified to NSF/ANSI 61.

#### CAPACITIES CHART

Model Number	Base Rate	**GPH of 50°F Drinking Water			Rated Watts	Full Load Amps	Glass† Filler Option	Ship. Wt. Lbs.
		Room Temperature °F						
		70°F	80°F	90°F				
EZS4	4.0	5.0	4.4	4.0	370	4.0	Yes	56
EZS8	8.0	9.7	8.8	8.0	370	4.0	Yes	56
EZ4	4.0	5.0	4.4	4.0	370	4.0	Yes	56
EZ8	8.0	9.7	8.8	8.0	370	4.0	Yes	56
EZSD	-	-	-	-	-	-	Yes	18
EZD	-	-	-	-	-	-	Yes	18

\*\*Based on 80°F inlet water temperature. †Glass filler available at extra cost. Requires factory preparation to receive glass filler.

Rated watts shown are based on operational (run) time, in compliance with A.R.I. Standard 1010 conditions. Specific applications will determine the actual watts consumed per hour. Watts consumed will be based on number of people served per hour (usage), ambient temperatures, and inlet water temperature.

#### COOLING SYSTEM

**Motor Compressor:** Hermetically sealed, reciprocating type, 115V, 60 Hz single phase. Sealed-in lifetime oil supply. Equipped with electric cord and three prong molded rubber plug (domestic models).

**Condenser:** Fan cooled, copper tube with aluminum fins. Fan motor is permanently lubricated.

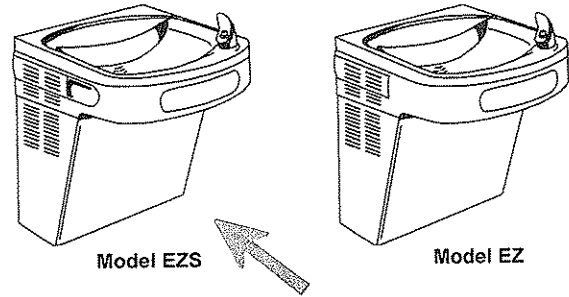

**Cooling Unit:** Combination tube-tank type. Self cleansing. Tube portion is continuous coil of copper tubing. Tank is stainless steel. Fully insulated with EPS foam which meets Underwriters Laboratories Inc. requirements for self-extinguishing material.

**Refrigerant Control:** Refrigerant HFC-134a is controlled by accurately calibrated capillary tube for positively trouble-free operation.

**Temperature Control:** Enclosed adjustable thermostat is factory pre-set. Requires no adjustment other than for altitude requirements. Easily accessible.

#### CONSTRUCTION

**Frame:** Galvanized structural steel chassis supports refrigeration system and fastens to wall. Provides increased structural integrity and rigidity to cooler.

**Stainless Steel Basin:** One piece polished to a uniform Elkay bright luster finish. Basin has integral drain grid, embossed bubbler pad. No exposed fasteners.

**Exclusive Flexi-Guard® Safety Bubbler\*:** Innovative design utilizes an infused anti-microbial pliable polyester elastomer to prevent accidental mouth injuries. Flexes on impact, then returns to original position. Strong. Abrasion-resistant. Anti-sweat. Keyed in location to prevent rotation.

**Upper Shroud:** Contoured shock-absorbing, provides additional protection against accidental injury. No exposed fasteners.

**Lower Shroud:** One piece easy to remove and replace. Allows access to internal components from three sides.

**Cabinet:** Cabinet design allows for flush to wall mounting. No recess space is required.

**Color Selection:** Unless otherwise specified cabinet is two-tone gray on upper shroud with textured gray lower shroud. Stainless Steel lower shroud available at extra cost.

**5 YEAR LIMITED WARRANTY** on the refrigeration system of the unit. Electrical components and water system are warranted for 12 months from date of installation. Sample Certificate available on request.

Elkay Pressure-Type Water Coolers are designed to operate on 20 psi to 105 psi supply line pressure. If inlet pressure is above 105 psi, a pressure regulator must be installed in the supply line. Any damage caused by reason of connecting this product to supply line pressures lower than 20 psi or higher than 105 psi is not covered by the warranty.

#### STANDARDS



Elkay Electric Air Cooled Water Coolers meet the requirements of NSF/ANSI 61. Unit complies with A.R.I. Standard 1010.

\* Patent #4,481,971

This specification describes an Elkay product with design, quality and functional benefits to the user. When making a comparison of other producers' offerings, be certain these features are not overlooked.

In keeping with our policy of continuing product improvement, Elkay reserves the right to change product specifications without notice.

Elkay

elkayusa.com

2222 Camden Court  
Oak Brook, IL 60523

Printed in U.S.A.  
©2006 Elkay

(Rev. 9/06) 12-23C

**Wall Mount Water Coolers**  
**Barrier-Free Access (Adult & Child)**  
**NSF/ANSI 61 Compliant**  
**Models EZ4, EZ8, EZS4, EZS8, EZSD and EZD**

**ELKAY®**  
**ROUGH-IN DIMENSIONS**

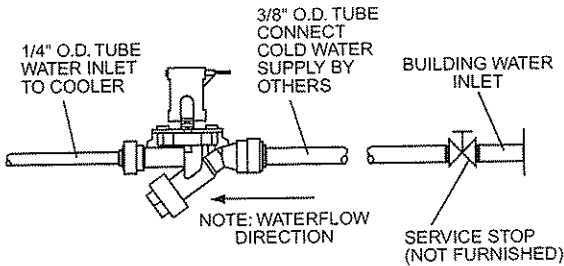

Open space rough-in design permits new installation or replacement of existing fountains and coolers with this Elkay cooler when rough-in is within the outline shown. When the cooler is mounted as shown the location available is from 15" to 21-11/16" from floor and 1-1/16" to 7-1/4" from the left of centerline. Space is also available from 21-11/16" to 24-5/8" from floor and 2-3/4" to 7-1/4" from the left of centerline. Additional space is also available from 24-5/8" to 26-11/16" from floor and 3-3/4" to 7-1/4" from the left of centerline. Connections approaching the limits of these areas may be restricted and should only be considered for use until after an examination of the cooler has been made.

**IMPORTANT!**  
**INSTALLER PLEASE NOTE:**

This water cooler has been designed and built to provide water to the user which has not been altered by materials in the cooler waterways.

The grounding of electrical equipment such as telephone, computers, etc., to water lines is a common procedure. This grounding may be in the building but may also occur away from the building. This grounding can cause electrical feedback into a water cooler creating an electrolysis which creates a metallic taste or causes an increase in the metal content of the water. This condition is avoidable by installing the cooler using the proper materials as shown below.

**NOTICE**

This water cooler must be connected to the water supply using a dielectric coupling. The cooler is furnished with a non-metallic strainer which meets this requirement.

The drain trap which is provided by the installer should also be plastic to completely isolate the cooler from the building plumbing system.

**OPERATION OF QUICK CONNECT FITTINGS**

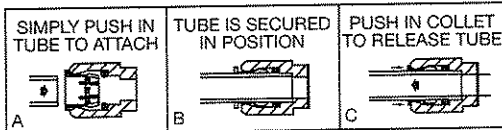

PUSHING TUBE IN BEFORE PULLING IT OUT HELPS TO RELEASE TUBE

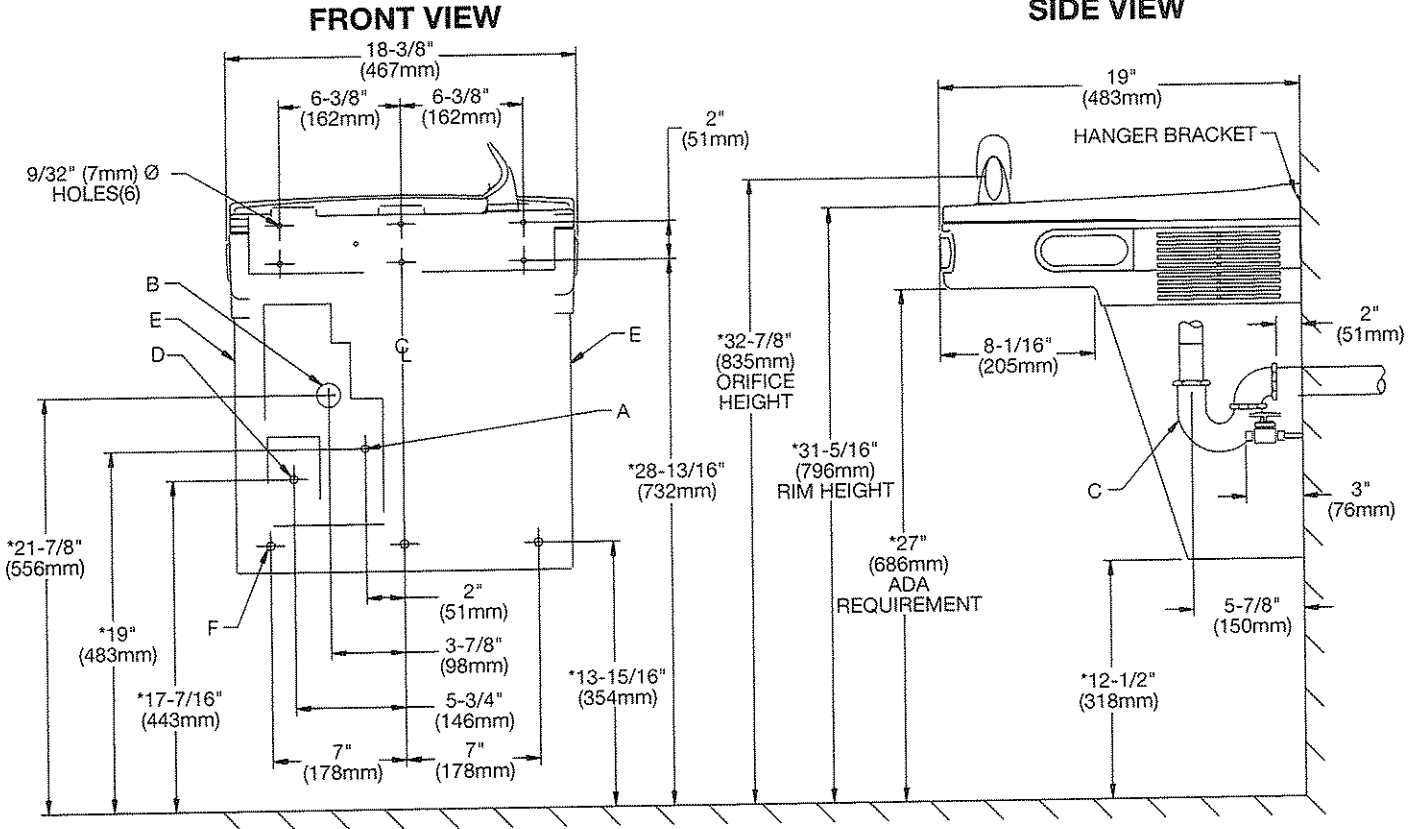

**LEGEND**

- A = RECOMMENDED WATER SUPPLY LOCATION 3/8" O.D. UNPLATED COPPER TUBE CONNECT STUB WITH SHUT OFF (BY OTHERS) 3 IN. (76mm) MAXIMUM OUT FROM WALL.
  - B = RECOMMENDED LOCATION FOR WASTE OUTLET 1-1/4" O.D. DRAIN STUB 2 IN. (51mm) OUT FROM WALL.
  - C = 1-1/4" TRAP NOT FURNISHED.
  - D = ELECTRICAL SUPPLY (3) WIRE RECESSED BOX.
  - E = INSURE PROPER VENTILATION BY MAINTAINING 6" (152mm) (MIN.) CLEARANCE FROM CABINET LOUVERS TO WALL.
  - F = 7/16" BOLT HOLES FOR FASTENING UNIT TO WALL.
- \*REDUCE HEIGHT BY 3 INCHES FOR INSTALLATION OF CHILDRENS ADA COOLER.



# S19-310AC, S19-310SBFW, S19-310TT Combination Drench Shower and Eye/Face Wash Unit

- Complies with American National Standard Z358.1-2004
- Galvanized Steel Protected with BRADTECT™ Safety Yellow Coating
- Universal Identification Sign and Inspection Tag Included
- Full, One-Year Warranty
- Patent Pending



**CERTIFIED  
MODEL  
Z358.1-2004**

## Specifications

Combination Drench Shower and Eye/Face Wash Unit saves space and fits easily into any work environment. Shower valve operates quickly by a pull rod with a triangular handle. Shower provides a superior washdown with a more even spray pattern. Eye/face wash operated by a large, highly visible push handle. Safe, steady water flow under varying water supply conditions from 30–90 PSI is assured by integral flow control in the sprayhead assembly. NOTE: The ANSI Z358.1 standard requires an uninterrupted supply of flushing fluid at a minimum 30 PSI flowing pressure.

### cUPC Approved:

S19-310AC, S19-310SBFW and S19-310TT are certified to comply with the requirements of the Uniform Plumbing Code and the National Plumbing Code of Canada by the International Association of Plumbing and Mechanical Officials (IAPMO).

## Standard Equipment

### SpinTec™ Showerhead

3.1" (78.7mm) diameter highly visible yellow impact-resistant plastic. Model S19-310TT includes a 10-3/4" (273mm) diameter corrosion-resistant stainless steel shroud. SpinTec drench showerhead features integral 23 GPM flow control, conserving water and helping to accurately size your tepid water system.

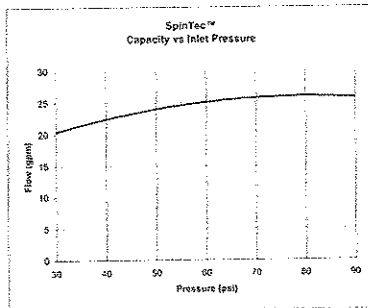

### Eyewash Bowl

10" (254mm) diameter yellow impact-resistant plastic or 10-3/4" (273mm) diameter corrosion-resistant stainless steel.

### Standard Sprayhead Assembly

Twin perforated-disc eye/face wash heads with protective pop-off sprayhead covers, operated by a large, highly visible push handle or a foot treadle (S19-310AC only). Safe, steady water flow under varying water supply conditions from 30–90 PSI is assured by integral flow control in the sprayhead assembly. NOTE: The ANSI Z358.1 standard requires an uninterrupted supply of flushing fluid at a minimum 30 PSI flowing pressure.

### Shower Valve

Chrome-plated brass 1" NPT stay-open ball valve. Operated by a stainless steel pull rod with triangular handle.

### Eyewash Valve

Chrome-plated brass 1/2" NPT stay-open ball valve. Hand operated by highly visible safety yellow PVC push handle (S19-310SBFW and S19-310TT) or stainless steel push handle (S19-310AC).

### Pipe and Fittings

1-1/4" galvanized steel with BRADTECT™ safety yellow coating.

### Water Supply

1-1/4" NPT.

### Recommended Option:

Navigator S19-2100 EFX25  
Emergency Thermostatic Mixing Valve

**NAVIGATOR**

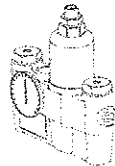

Satisfies ANSI Z358.1-2004  
tepid water requirements.

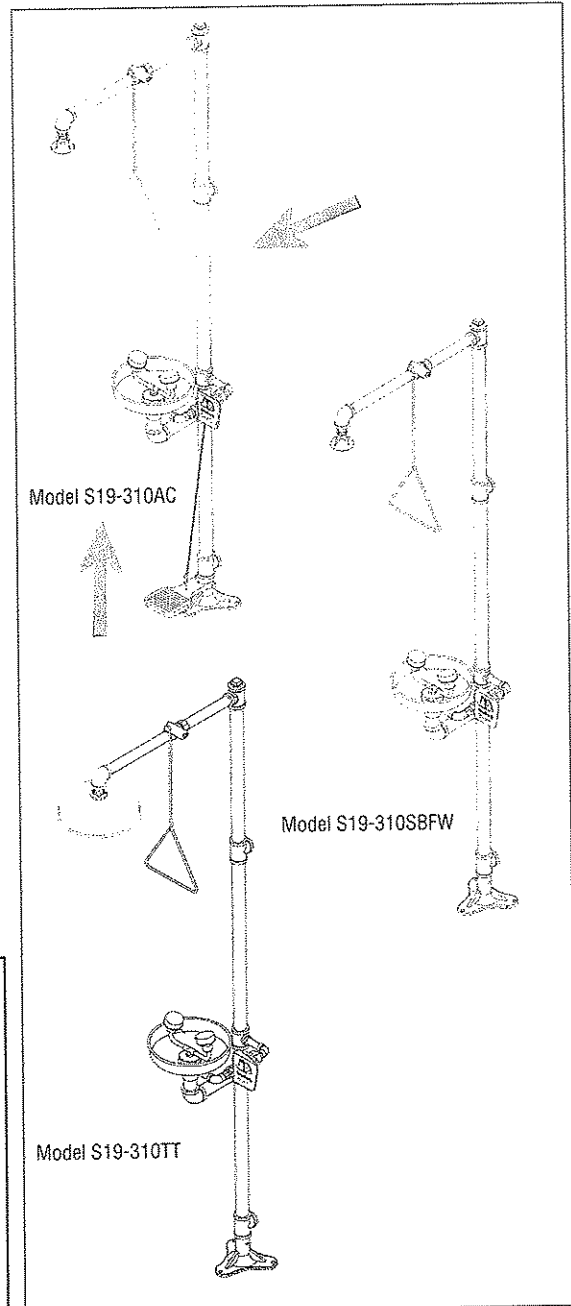



# S19-310AC, S19-310SBFW, S19-310TT Combination Drench Shower/Eye/Face Wash Unit

Model	Description
<input type="checkbox"/> S19-310AC	Drench Shower/Eyewash - Plastic Showerhead and Stainless Steel Bowl with Foot Treadle Operation
<input type="checkbox"/> S19-310SBFW	Drench Shower/Eyewash - Plastic Showerhead and Stainless Steel Bowl
<input type="checkbox"/> S19-310TT	Drench Shower/Eyewash - Stainless Steel Showerhead and Stainless Steel Bowl
<input type="checkbox"/> S19-2100	Navigator EFX25 - Emergency Thermostatic Mixing Valve



Local codes may require the installation of a backflow prevention valve to complete proper installation. Compliance with local codes is the responsibility of the installer. Valve must be tested annually to verify that it is functioning properly. Backflow prevention valves are not included with the fixture and may be supplied by the contractor or purchased from Bradley Corporation.

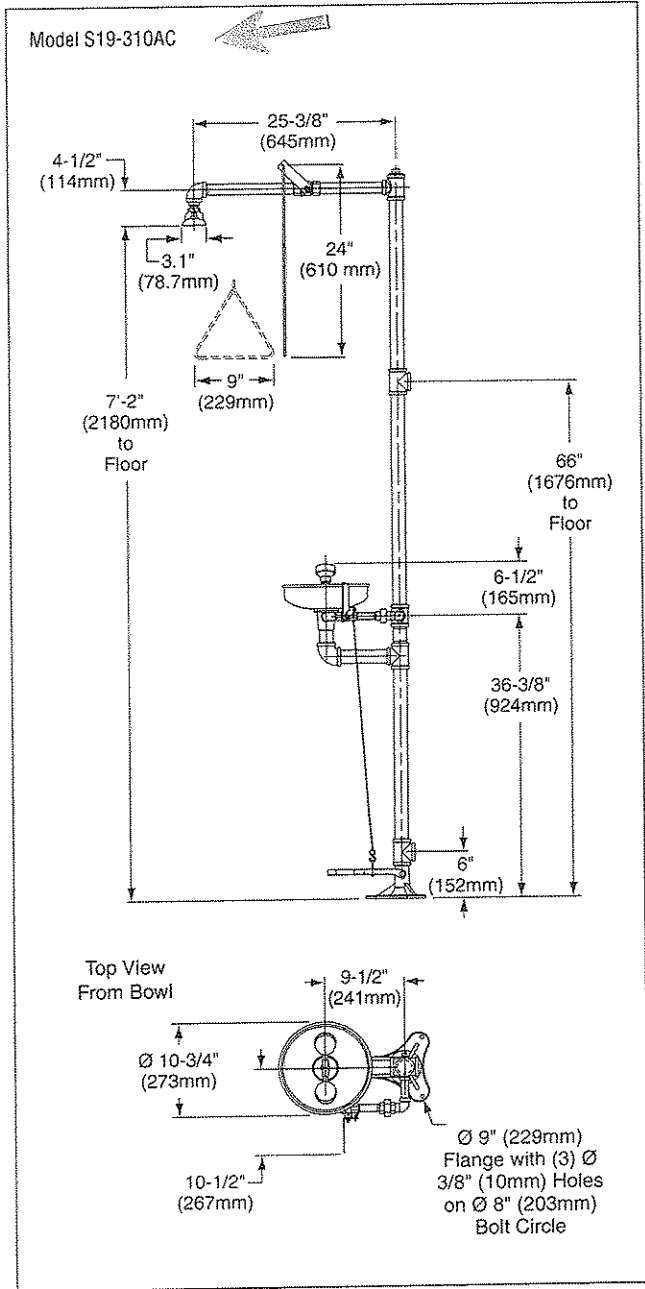

All dimensions assume standard thread engagement. Variations in manufacturing allow for +/- 1/8" (3mm) per threaded joint. To find the tolerance of a dimension, add the number of thread joints in between a dimension and multiply it by 1/8" (3mm).

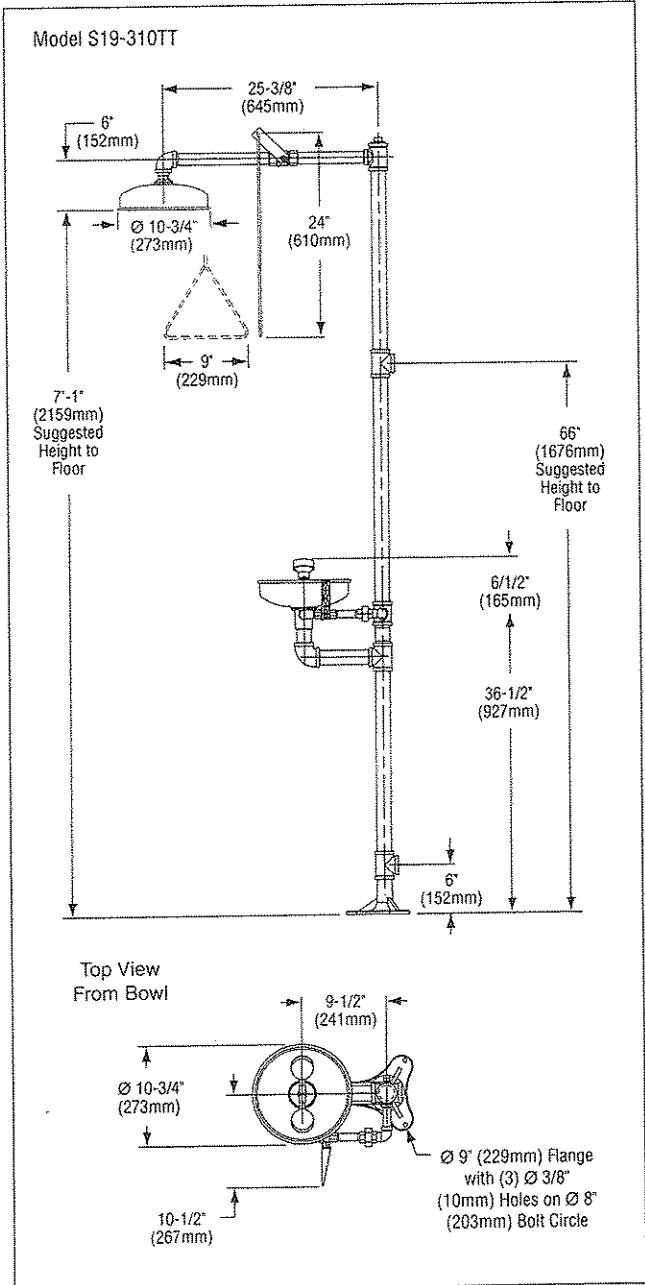
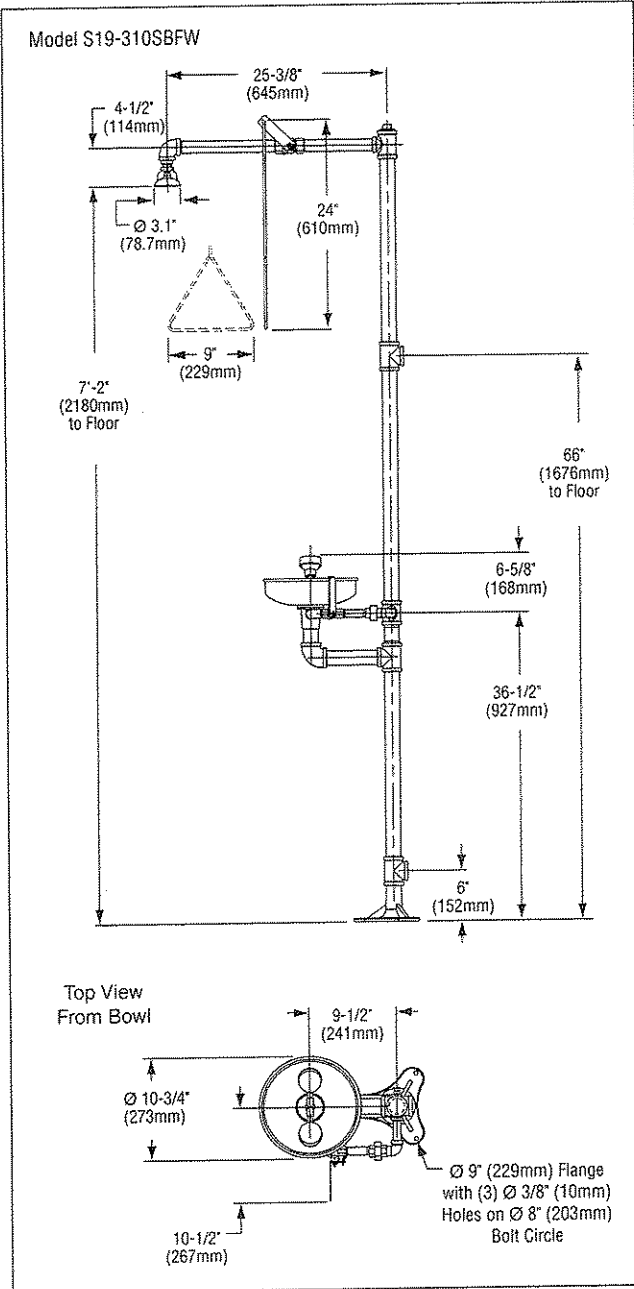

All dimensions assume standard thread engagement. Variations in manufacturing allow for +/- 1/8" (3mm) per threaded joint. To find the tolerance of a dimension, add the number of thread joints in between a dimension and multiply it by 1/8" (3mm).

**SERIES TSB-3000** (Square and Rectangular - 6" dropped front with 12" high side and back walls)

Models TSB-3000, TSB-3001, TSB-3002 and TSB-3003 shall be supplied with continuous stainless steel caps on all curbs (See Table II)

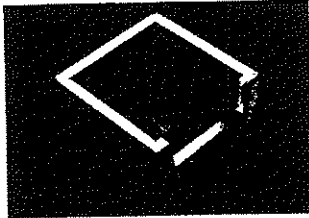

**MODEL TSB-3010 SHOWN**  
Models TSB-3010, TSB-3011, TSB-3012 and TSB-3013 shall be supplied with stainless steel cap on dropped threshold curb only (See Table III)

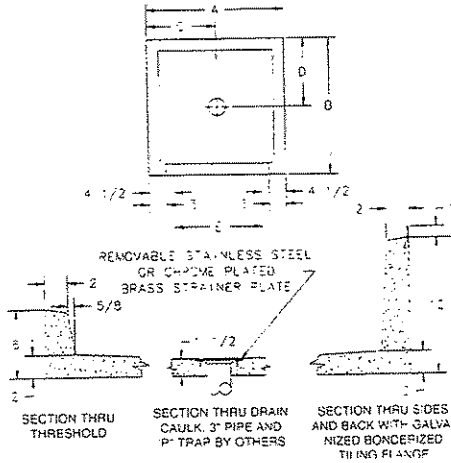

**TABLE II - Series TSB-3000**  
**With Stainless Steel Caps On All Curbs**

MODEL	SIZE	A	B	C	D	E
TSB-3000	24x24x12	24	24	12	12	15
TSB-3001	32x32x12	32	32	16	16	23
TSB-3002	36x36x12	36	36	18	18	27
TSB-3003	36x24x12	36	24	18	12	27

**TABLE III -- Series TSB-3000**  
**With Stainless Steel Threshold Only**

MODEL	SIZE	A	B	C	D	E
TSB-3010	24x24x12	24	24	12	12	15
TSB-3011	32x32x12	32	32	16	16	23
TSB-3012	36x36x12	36	36	18	18	27
TSB-3013	36x24x12	36	24	18	12	27



**KINGSTON™**

**BOWL  
K-4330**

**ADA**

**Features**

- 1-1/2" top spud
- Vitreous china
- Elongated bowl
- Wall-mount
- 1.6 gpf (6 lpf)
- ADA compliant when installed at required height of 17"-19" from floor to top of seat
- With bedpan lugs (-L)
- Siphon jet
- 12-3/8" (31.4 cm) x 11-3/8" (28.9 cm) water area

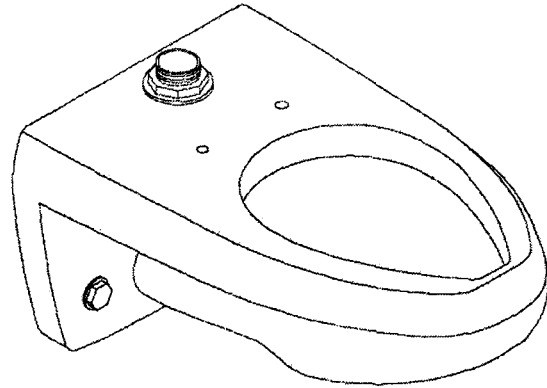

**Codes/Standards Applicable**

Specified model meets or exceeds the following:

- ADA
- ASME A112.19.2
- ASME A112.19.6
- ICC/ANSI A117.2
- Energy Policy Act of 1992 (EPACT)
- IAPMO/UPC
- CSA B125

**Colors/Finishes**

- 0: White
- Other: Refer to Price Book for additional colors/finishes

**Accessories**

- 0: White
- Other: Refer to Price Book for additional colors/finishes

**Specified Model**

Model	Description	Colors/Finishes	
K-4330	Elongated bowl toilet	<input checked="" type="checkbox"/> 0 White	<input type="checkbox"/> Other _____
K-4330-L	Elongated bowl toilet with bedpan lugs	<input type="checkbox"/> 0 White	<input type="checkbox"/> Other _____
Recommended Accessories			
K-4670-C	Lustra™ open front seat	<input type="checkbox"/> 0 White	<input type="checkbox"/> Other _____
K-4670-CA	Lustra™ open front seat (with anti-microbial agent)	<input type="checkbox"/> 0 White	

**Product Specification:**

The elongated bowl shall be wall-mount with a 1-1/2" top spud. Bowl shall be made of vitreous china. Bowl shall have 12-3/8" (31.4 cm) x 11-3/8" (28.9 cm) water area. Bowl shall be 1.6 gpf (6 lpf). Bowl shall be ADA compliant when installed at required height of 17" (43.2 cm) - 19" (48.3 cm) from the floor to the top of the seat. Bowl shall have bedpan lugs (-L). Bowl shall have siphon jet. Bowl shall be Kohler Model K-4330-\_\_\_\_\_

# KINGSTON™

## Technical Information

ADA compliant	
Fixture:	
Configuration	top spud, elongated
Water per flush	1.6 gallons (6 L)*
Spud size	1-1/2"
Passageway	2-1/4" (5.7 cm)
Water area	12-3/8" (31.4 cm) x 11-3/8" (28.9 cm)
Water depth from rim	5-1/4" (13.3 cm)
Seat post hole centers	5-1/2" (14 cm)
* Designed to flush with 1.6 (6 L) gallons of water when installed with a 1.6 (6 L) gpf flush valve.	
Included components:	
Spud	18357
Flush valve requirements: Refer to manufacturer and local codes.	

## Installation Notes

Install this product according to the installation guide.

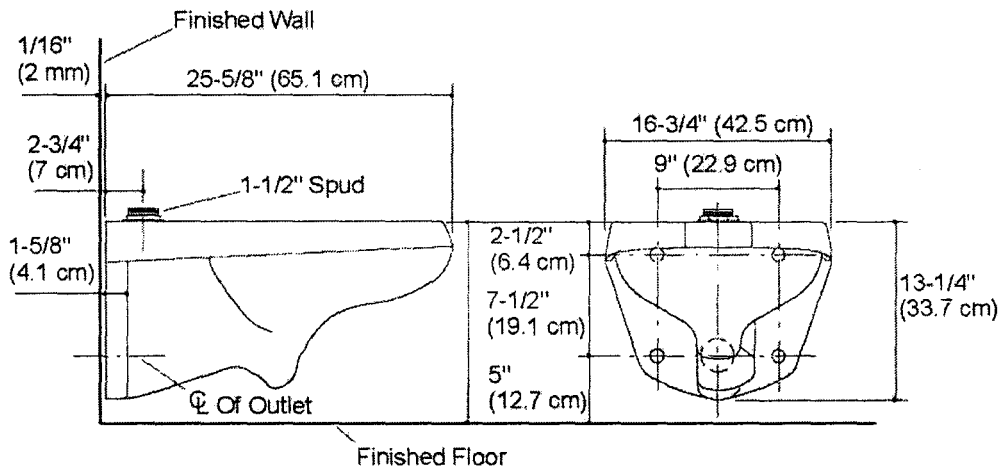

## Product Diagram

COMMERCIAL PLASTIC SEATS



Seats shall be No. \_\_\_\_\_ as manufactured by Church Seats. Seats shall be heavy weight and injection molded of solid plastic. Seats shall be open front less cover for elongated bowl and feature large molded-in bumpers. External check hinges to feature 300 Series stainless steel posts that stop seat 11 degrees beyond vertical. Uses 300 Series stainless steel hardware. Color to be \_\_\_\_\_ (specify white or fixture manufacturer's color.) Hinges shall be \_\_\_\_\_.

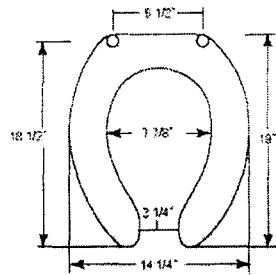
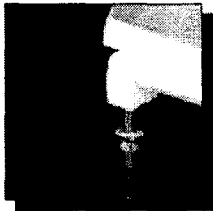

MODEL 295C ←

- ◆ ELONGATED SEAT  
OPEN FRONT LESS COVER

---

- ◆ SOLID PLASTIC

---

- ◆ EXTERNAL 300 SERIES  
STAINLESS STEEL CHECK HINGES



- 295C Open front seat less cover/external check hinge stops seat 11° beyond vertical.
  - 295SSC Open front seat less cover/stainless steel, self-sustaining and external check hinge holds seat in any raised position up to 11° beyond vertical.
- Ring thickness is 13/16"  
Ring thickness including the bumper is 1"  
Height of the seat is 2-1/4"

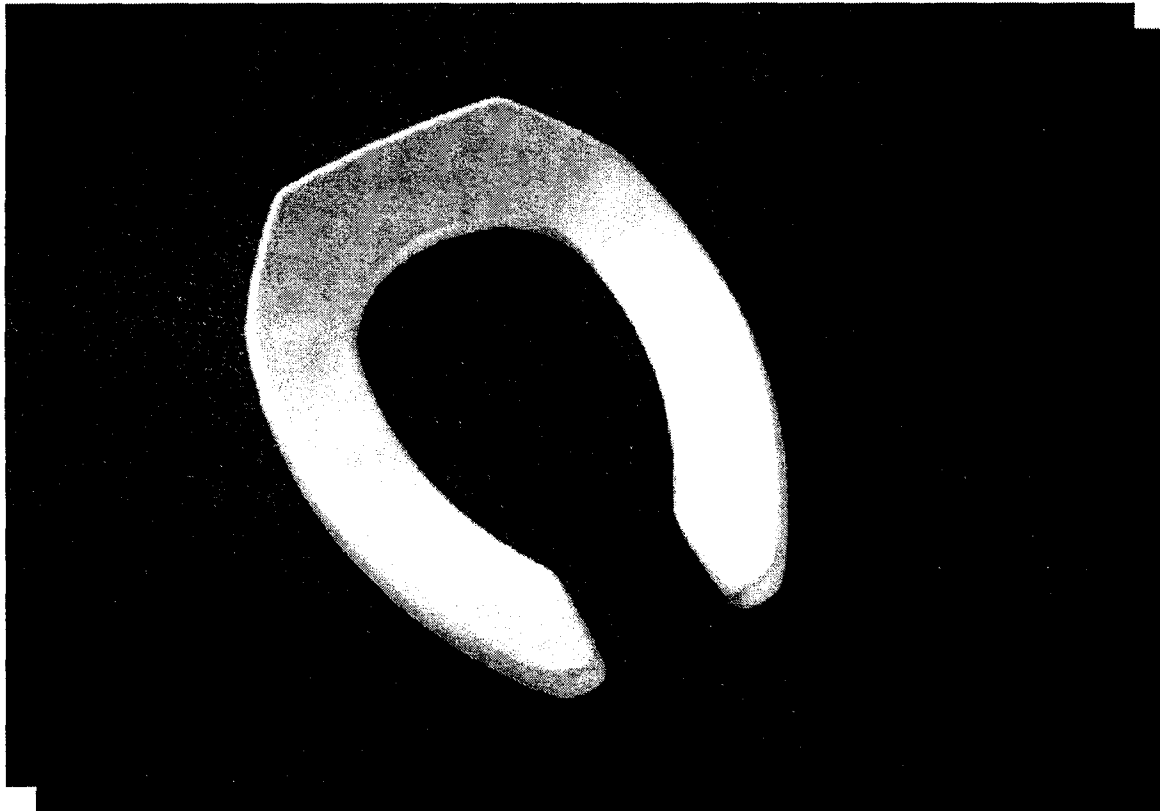



Z-1203-N ADJUSTABLE HORIZONTAL SIPHON JET- No-Hub

TAG \_\_\_\_\_

Dimensions Subject to Manufacturing Tolerances

Product No.	Approx. Wt. Lbs.
Z-1203-NL4	67
Z-1203-NR4	

Note:

1. Min. 'P' Dim. Obtainable = 1-3/4"
2. Feet bolted to floor using min. 1/2 dia. bolts and back slots on carrier feet.
3. Back anchor foot required for secure installation.

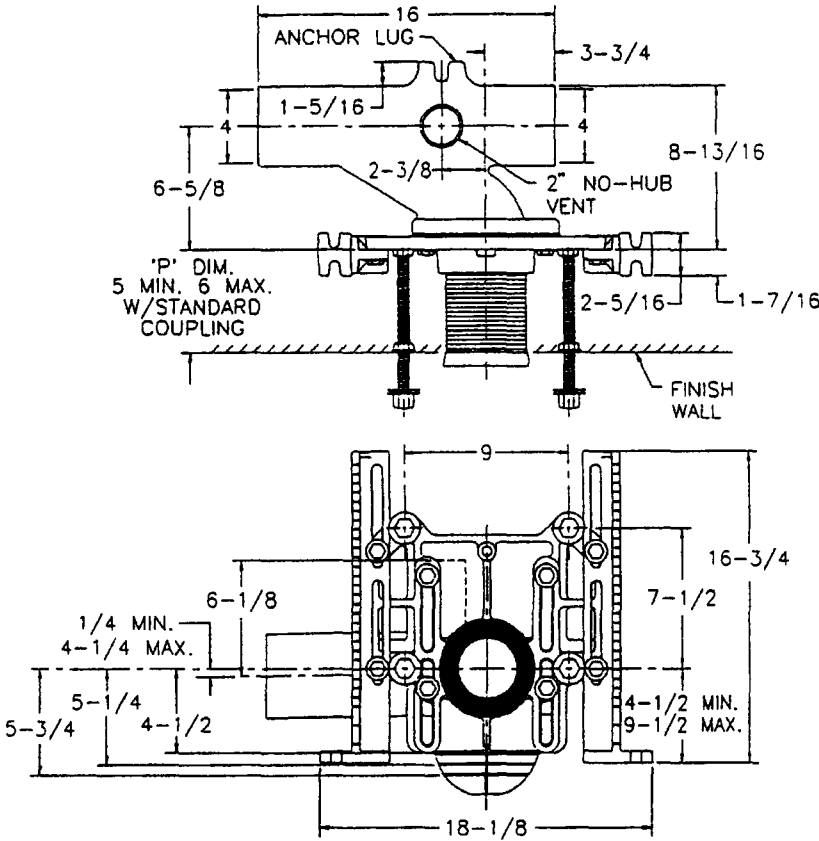

**ENGINEERING SPECIFICATION:** ZURN Z-1203-N ( ) Adjustable, horizontal siphon jet water closet "Rigid System" with 4" No-Hub connections. Complete with Dura-Coated cast iron right hand or left hand main fitting, with 2" vent, adjustable gasketed face plate, universal floor mounted foot supports, corrosion resistant adjustable ABS coupling with integral test cap, fixture bolts, trim, and stud protectors. Rear anchor tie down and bonded "Neo-Seal" gasket.

PRODUCT/DEFINITION

- \_\_\_\_\_ Z-1203-NR4 4" No-Hub Right Hand Inlet with Flow to Left
- \_\_\_\_\_ Z-1203-NL4 4" No-Hub Left Hand Inlet with Flow to Right

PREFIXES

- \_\_\_\_\_ Z- D.C.C.I. System with Zurn "ZZ" Adjustable Coupling\*
- \_\_\_\_\_ ZQ- D.C.C.I. System with Non-Adjustable Coupling

SUFFIXES

- |           |  |           |   |
|-----------|--|-----------|---|
| _____ -A  | Auxiliary Support Assembly (For P-Dim. greater than 18")             | _____ -VP | Vandal Proof Trim   |
| _____ -B  | Blowout Type Fixture Support   | _____ -W  | Adapter for Womens Urinal   |
| _____ -BC | Back Cleanout  | _____ -29 | Mechanical Test Cap Assembly (Previously Z-1210-29)   |
| _____ -CC | Cast Iron Coupling 6" Long   | _____ -45 | Finishing Frame for Siphon Jet System (For Blowout System specify -45-B) (Previously Z-1210-45) |
| _____ -CL | Coupling Length Greater than 12" (Specify length if greater than 6") | _____ -50 | Flush Valve Supply Support for W.C. (Previously Z-1210-50)                                      |
| _____ -F  | Floor Mounted Back Outlet, Fixture Support                           | _____ -61 | "ZZ" Coupling Wrench  |
| _____ -G  | Galvanized Cast Iron   |           |   |
| _____ -M  | Auxiliary Foot Support (For P-Dim. 10"-18")                          |           |   |
| _____ -T  | Threaded Stack Connection (Available on Restricted Basis Only)       |           |   |

REV. A DATE: 9/20/91 C.N. NO. 67825

\*REGULARLY FURNISHED UNLESS OTHERWISE SPECIFIED DRAWING NO. 54353 PRODUCT NO. Z-1203-N



Z-1203-ND ADJUSTABLE HORIZONTAL  
BACK TO BACK SIPHON JET- No-Hub

TAG \_\_\_\_\_

Dimensions Subject to Manufacturing Tolerances

Product No.	Approx. Wt. Lbs.
Z-1203-ND4	120

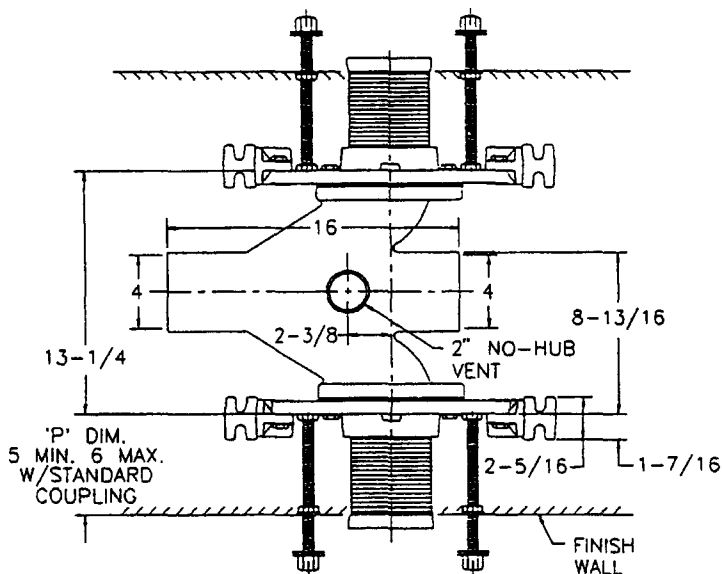

Note:

1. Min. 'P' Dim. Obtainable = 1-3/4"
2. Feet bolted to floor using min. 1/2 dia. bolts and back slots on carrier feet.

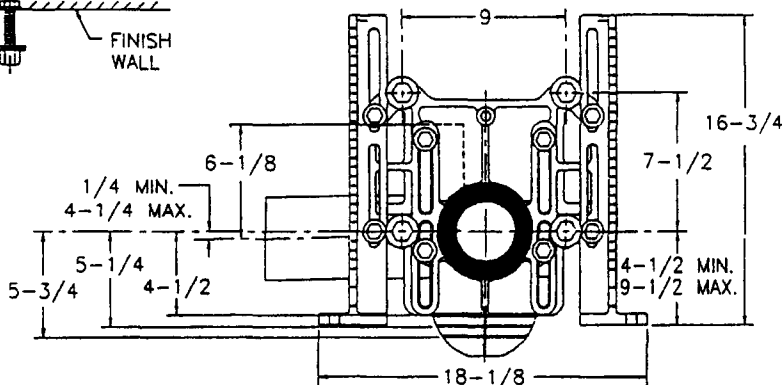

**ENGINEERING SPECIFICATION:** ZURN Z-1203-ND4 Adjustable, horizontal siphon jet water closet "Rigid System" with 4" No-Hub connections. Complete with Dura-Coated cast iron fitting, with 2" vent, adjustable gasketed face plates, universal floor mounted foot supports, corrosion resistant adjustable ABS couplings with integral test cap, fixture bolts, trim, and stud protectors. Rear anchor tie down and bonded "Neo-Seal" gaskets.

**PRODUCT/DEFINITION**

\_\_\_\_\_ Z-1203-ND4 4" No-Hub Back to Back Inlet (Double)

**PREFIXES**

\_\_\_\_\_ Z- D.C.C.I. System with Zurn "ZZ" Adjustable Coupling\*  
 \_\_\_\_\_ ZQ- D.C.C.I. System with Non-Adjustable Coupling

**SUFFIXES**

_____ -A	Auxiliary Support Assembly (For P-Dim. greater than 18")	_____ -VP	Vandal Proof Trim
_____ -B	Blowout Type Fixture Support	_____ -W	Adapter for Womens Urinal
_____ -BC	Back Cleanout	_____ -29	Mechanical Test Cap Assembly (Previously Z-1210-29)
_____ -CC	Cast Iron Coupling 6" Long	_____ -45	Finishing Frame for Siphon Jet System (For Blowout System specify -45-B) (Previously Z-1210-45)
_____ -CL	Coupling Length Greater than 12" (Specify length if greater than 6")	_____ -50	Flush Valve Supply Support for W.C. (Previously Z-1210-50)
_____ -F	Floor Mounted Back Outlet, Fixture Support	_____ -61	"ZZ" Coupling Wrench
_____ -G	Galvanized Cast Iron		
_____ -M	Auxiliary Foot Support (For P-Dim. 10"-18")		
_____ -T	Threaded Stack Connection (Available on Restricted Basis Only)		

REV. A DATE: 9/20/91 C.N. NO. 67825

\*REGULARLY FURNISHED UNLESS OTHERWISE SPECIFIED DRAWING NO. 54354 PRODUCT NO. Z-1203-ND



**Z-1204-N**  
**ADJUSTABLE VERTICAL SIPHON**  
**JET-NO-HUB**

SPECIFICATION SHEET

TAG \_\_\_\_\_

Dimensional Data (Inches and [ mm ]) are Subject to Manufacturing Tolerances and Change Without Notice

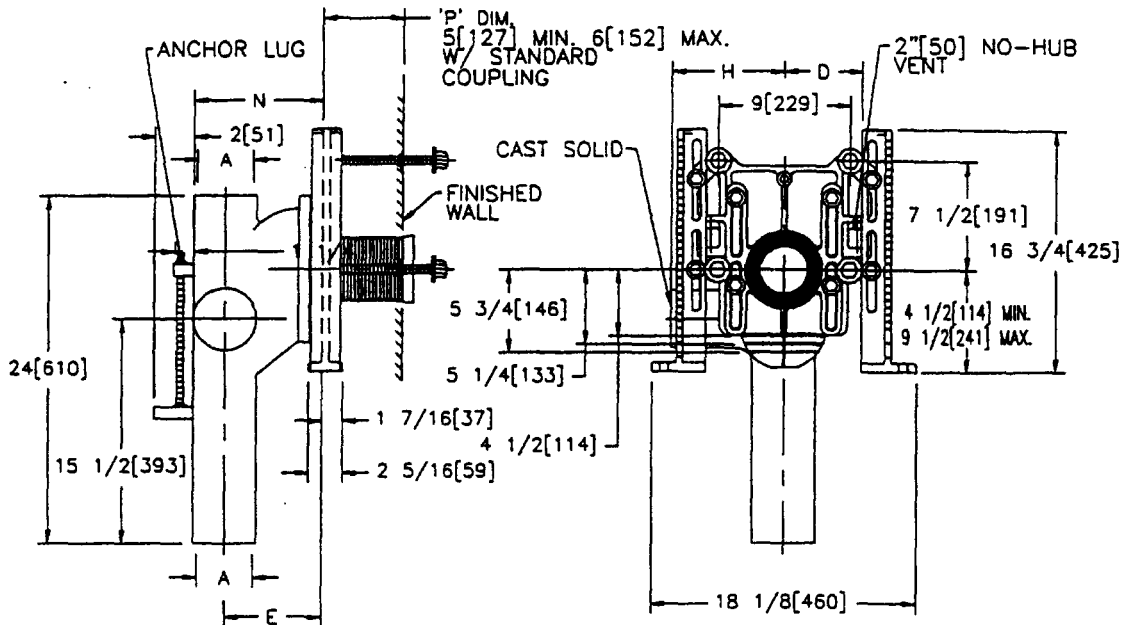

**Note:**

1. Min. 'P' Dim. Obtainable=2 [51]
2. 2 No-Hub vent connection regularly furnished on right hand side. Left hand available when specified (Suffix- VL)
3. Auxiliary inlet available right (~JR) or left (~JL) or both sides (~JJ) when specified.
4. Feet bolted to floor using min. 1/2 [13] dia. bolts and back slots on carrier feet.
5. Back anchor foot required for secure installation.

Product No.	Dimensions in Inches					Approx. Wt.Lbs. [kg]
	A	D	E	H	N	
Z-1204-N4	4 [102]	5 [127]	6 5/8 [168]	5 1/2 [140]	8 7/8 [225]	80 [36]
Z-1204-N5	5 [127]	5 1/2 [140]	6 5/8 [168]	6 1/2 [165]	9 3/8 [238]	85 [39]
Z-1204-N6	6 [152]	6 [152]	7 1/8 [181]	6 1/2 [165]	10 3/8 [264]	95 [43]

**ENGINEERING SPECIFICATION:**

ZURN Z-1204-N( ) Adjustable, vertical siphon jet water closet "Rigid System" with ( ) size No-Hub connections and ( ) side inlets. Complete with Dura-Coated cast iron left hand fitting, with 2 [51] vent, adjustable gasketed face plate, universal floor mounted foot supports, corrosion resistant adjustable ABS coupling with integral test cap, fixture bolts, trim, and stud protectors. Rear anchor tie down, and bonded "Neo-Seal" gasket.

**PRODUCT/DEFINITION**

\_\_\_\_\_ Z-1204-N No-Hub Stack, Single Inlet, 2 [51] Right Hand Vent

**PREFIXES**

- \_\_\_\_\_ Z- D.C.C.I. System with Zurn "ZZ" Adjustable Coupling
- \_\_\_\_\_ ZQ- D.C.C.I. System with NPT Face Plate, Non-Adjustable Coupling

**SUFFIXES**

- \_\_\_\_\_ -A Auxiliary Support Assembly (For P-Dim. greater than 18 [457])
- \_\_\_\_\_ -B Blowout Type Fixture Support
- \_\_\_\_\_ -BC Back Cleanout
- \_\_\_\_\_ -CC Corrosion Resistant 6 [152] Long Cast Iron Coupling
- \_\_\_\_\_ -CL Coupling Length Greater than 12 [305] (Specify length if greater than 6 [152])
- \_\_\_\_\_ -F Floor Mounted Back Outlet, Closet Connection
- \_\_\_\_\_ -G Galvanized Cast Iron
- \_\_\_\_\_ -JJ Two 2 [51] Auxiliary Inlet
- \_\_\_\_\_ -JL 2 [51] Left Hand Auxiliary Inlet
- \_\_\_\_\_ -JR 2 [51] Right Hand Auxiliary Inlet
- \_\_\_\_\_ -M Auxiliary Foot Support (For P-Dim. 10 [254] to 18 [457])
- \_\_\_\_\_ -T Threaded Stack Connection
- \_\_\_\_\_ -VL Left Hand Vent Connection
- \_\_\_\_\_ -VP Vandal Proof Trim
- \_\_\_\_\_ -W Adapter Assembly for Womens Urinal
- \_\_\_\_\_ -29 Mechanical Test Cap Assembly (Previously Z-1210-29)
- \_\_\_\_\_ -45 Finishing Frame for Siphon Jet Closet (For Blowout System specif -45-B)
- \_\_\_\_\_ -50 Flush Valve Supply Support for W.C. (Previously Z-1210-50)
- \_\_\_\_\_ -61 Adjusting Wrench for "ZZ" Coupling

\*REGULARLY FURNISHED UNLESS OTHERWISE SPECIFIED

REV.	DATE: 03/21/95	C.N. NO. 71120
DWG. NO. 58842	PRODUCT NO. Z-1204-N	



**Z-1204-ND ADJUSTABLE VERTICAL SIPHON JET-No-Hub**

**TAG** \_\_\_\_\_

Dimensions Subject to Manufacturing Tolerances

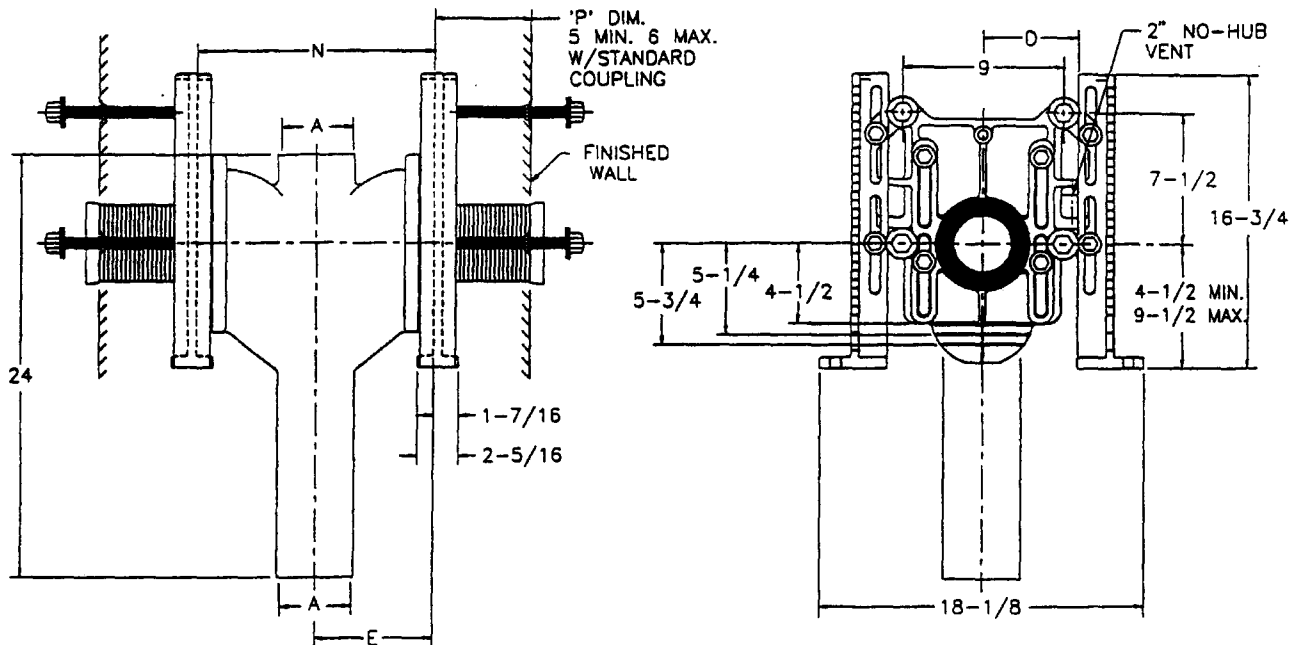

Product No.	Dimensions in Inches					Approx. Wt. Lbs.
	A	D	E	H	N	
Z-1204-ND4	4	5	6-5/8	5-1/2	13-1/4	139
Z-1204-ND5	5	5-1/2	6-5/8	6-1/2	13-1/4	140
Z-1204-ND6	6	6	7-1/8	6-1/2	14-1/4	145

- Note:**
1. Min. 'P' Dim. Obtainable=2"
  2. Two 4" or 5" side inlets as indicated.
  3. Feet bolted to floor using min. 1/2 dia. bolts and back slots on carrier feet.

**ENGINEERING SPECIFICATION:** ZURN Z-1204-ND( ) Adjustable, vertical siphon jet water closet "Rigid System" with ( ) size No-Hub connections and ( ) side inlets. Complete with Dura-Coated cast iron right and left hand fitting, with 2" vent, adjustable gasketed face plate, universal floor mounted foot supports, corrosion resistant adjustable ABS coupling with integral test cap, fixture bolts, trim, and stud protectors. Rear anchor tie down, and bonded "Neo-Seal" gasket.

**PRODUCT/DEFINITION**

\_\_\_\_\_ Z-1204-ND No-Hub Stack, Double Inlets, 2" Vent.

**PREFIXES**

- \_\_\_\_\_ Z- D.C.I. System with Zurn "ZZ" Adjustable Coupling
- \_\_\_\_\_ ZQ- D.C.I. System with NPT Face Plate, Non Adjustable Coupling

**SUFFIXES**

- |           |  |           |   |
|-----------|--|-----------|---|
| _____ -A  | Auxiliary Support Assembly (For P-Dim. greater than 18")             | _____ -T  | Threaded Stack Connection   |
| _____ -B  | Blowout Type Fixture Support   | _____ -VL | Left Hand Vent Connection   |
| _____ -BC | Back Cleanout  | _____ -VP | Vandal Proof Trim   |
| _____ -CC | Cast Iron Coupling 6" Long   | _____ -W  | Adapter for Womens Urinal   |
| _____ -CL | Coupling Length Greater than 12" (Specify length if greater than 6") | _____ -29 | Mechanical Test Cap Assembly (Previously Z-1210-29)   |
| _____ -F  | Floor Mounted Back Outlet, Fixture Support                           | _____ -45 | Finishing Frame for Siphon Jet System (For Blowout System specify -45-B) (Previously Z-1210-45) |
| _____ -G  | Galvanized Cast Iron   | _____ -50 | Flush Valve Supply Support for W.C. (Previously Z-1210-50)                                      |
| _____ -JJ | 2" Auxiliary Inlet   | _____ -61 | "ZZ" Coupling Wrench  |
| _____ -JL | 2" Left Hand Auxiliary Inlet   |           |   |
| _____ -JR | 2" Right Hand Auxiliary Inlet  |           |   |
| _____ -M  | Auxiliary Foot Support (For P-Dim. 10"-18")                          |           |   |

REV. A	DATE: 8/9/94	C.N. NO. 69939
DRAWING NO. 56985		PRODUCT NO. Z-1204-ND

\*REGULARLY FURNISHED UNLESS OTHERWISE SPECI-

ZURN INDUSTRIES, INC., HYDROMECHANICS DIV., 1801 Pittsburgh Ave., Erie, PA 16514 Phone: 814/455-0921 Fax: 814/454-7929



**CHESAPEAKE™**

**WALL-MOUNT LAVATORY**

**K-1722, K-1724,  
K-1728**

**ADA**

**FEATURES**

- 19-1/4"(48.9cm) x 17-1/4"(43.8cm)
- Vitreous china
- Ledge-back
- 8"(20.3cm) centers (K-1724), 4"(10.2cm) centers (K-1728) or single-hole (K-1722)
- With overflow
- ADA compliant
- With hanger
- Drilled for concealed arm carrier

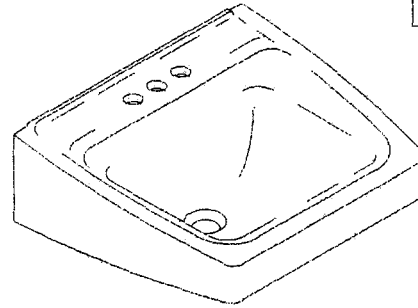

**CODES/STANDARDS APPLICABLE**

Specified model meets or exceeds the following:

- ADA
- ASME/ANSI A112.19.2M
- CABO/ANSI A117.1
- IAPMO/UPC
- State of Massachusetts

**COLORS/FINISHES**

- 0 White
- Other Refer to Fixtures Price Book for additional colors

**Accessories:**

- CP Polished Chrome
- Other Refer to Faucets Price Book for additional finishes

**SPECIFIED MODEL:**

Model	Description	Colors/Finishes	
K-1724	8" (20.3cm) centers lavatory	<input type="checkbox"/> 0 White	<input type="checkbox"/> Other _____
K-1728	4" (10.2cm) centers lavatory	<input checked="" type="checkbox"/> 0 White	<input type="checkbox"/> Other _____
K-1722	Single-hole lavatory	<input type="checkbox"/> 0 White	<input type="checkbox"/> Other _____
Recommended Accessories			
K-8998	Trap	<input type="checkbox"/> CP	<input type="checkbox"/> Other _____

**PRODUCT SPECIFICATION:**

The lavatory shall be 19-1/4" (48.9cm) in length, and 17-1/4" (43.8cm) in width. Lavatory shall be made of vitreous china. Lavatory shall be ledge-back with hanger. Lavatory shall have 8" (20.2cm) centers (K-1724), 4" (10.2cm) centers (K-1728), or single-hole (K-1722) drilling. Lavatory shall be drilled for concealed arm carrier. Lavatory shall have overflow. Lavatory shall be ADA compliant. Lavatory shall be Kohler Model K-\_\_\_\_\_.

*We reserve the right to make revisions without notice in the design of fixtures or in packaging unless this right has specifically been waived at the time the order is accepted.*

Page 1 of 2  
105028-4-CB

# CHESAPEAKE™

## PRODUCT INFORMATION

ADA compliant.			
Fixture*:		basin area	water depth
Lavatory		14" (35.6cm) x 11" (27.9cm)	4-7/8" (12.4cm)
Drain hole	1-3/4" D. (4.4cm)		
* Approximate measurements for comparison only.			
Holes	<b>K-1724</b>	<b>K-1728</b>	<b>K-1722</b>
Spout	1-3/8" D. (3.5cm)	1-1/4" D. (3.2cm)	1-3/8" D. (3.5cm)
Faucet	1-3/8" D. (3.5cm)	1-1/4" D. (3.2cm)	
Soap dispenser			1-1/4" D. (3.2cm)
Included Components:			
Hanger			64839

## INSTALLATION NOTES

Install this product according to the installation guide.  
 Fixture dimensions are nominal and conform to tolerances in ASME Standard A112.19.2M.  
 Concealed arm carrier required, **NOT** supplied by Kohler Co.  
 Supplied hanger not used with concealed arm carrier.

### CONCEALED ARM HOLE LOCATIONS

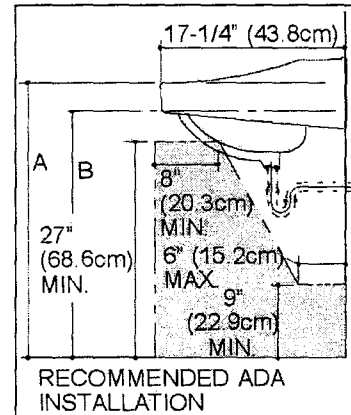
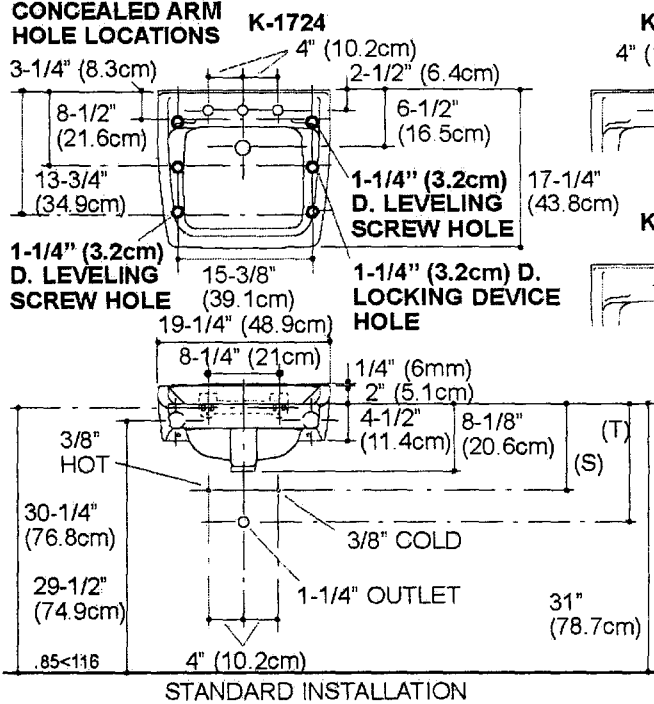



ADA rim height = A	ADA arm carrier height = B
34" (86.4cm) Max.	33" (81.9cm) Max.
(T) Pop-up drain 13-3/4" (34.9cm), grid drain 12-7/8" (32.7cm).	
(S) 10" (25.4cm) (Based on 12" (30.5cm) riser which may require cutting).	

## PRODUCT DIAGRAM

K-1722, K-1724, K-1728 Chesapeake™ Lavatory  
 Page 2 of 2  
 105028-4-CB

THE BOLD LOOK  
 OF **KOHLER**®

	<p><b>McGUIRE MFG. CO., INC.</b>                  60 Grandview Court                  P.O. Box 746 ♣ Cheshire, CT 06410                  203-699-1801 ♣ Fax 203-699-1813</p>	<p><b>Part No.</b>                  155A </p> <p>Open Grid P.O. Plug</p>
<b>Product Specification</b>		

**Job Name:** \_\_\_\_\_ **Submittal Number:** \_\_\_\_\_

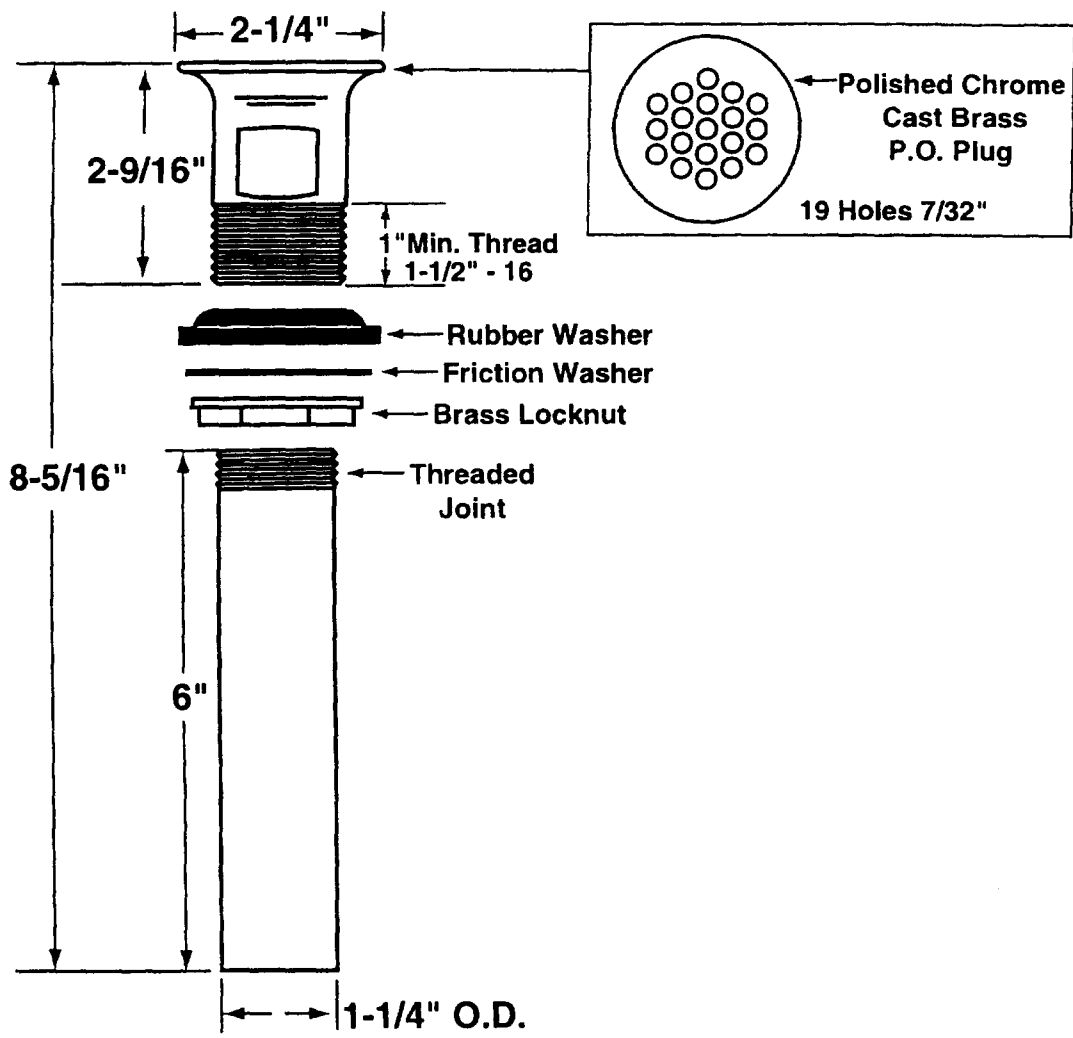

\*Available with 1 1/2" O.D. brass tailpiece, specify Part # 155A2



See accessories section for details on product variations.

**Specifications:**

Cast Brass Chrome Plated Open Grid P.O. Plug with 17 gauge 1-1/4" x 6" seamless brass tailpiece, brass locknut, heavy rubber basin washer and fiber friction washer. P.O. plug shall be in compliance with CSA or other recognized testing authority and bear both manufacturer and testing mark.



**FEATURES**

- Cast brass construction
- Adjustable rotation on tube outlet
- Slip-joint inlet
- Cleanout plug
- Flange

**P-TRAP  
K-8998**  
ALSO K-8999, K-9000

**CODES/STANDARDS APPLICABLE**

Specified model meets or exceeds the following:

- ASME/ANSI A112.18.1M
- IAPMO/UPC

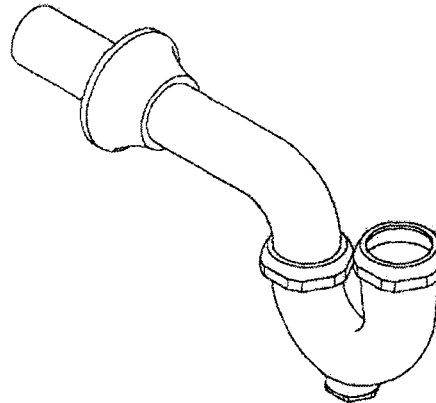

**COLORS/FINISHES**

- CP Polished Chrome
- Other Refer to Faucets Price Book for additional finishes

**SPECIFIED MODEL:**

Model	Description	<input type="checkbox"/> CP	<input type="checkbox"/> Other_____
K-8998	With 1-1/4" O.D. Inlet and 1-1/4" O.D. Outlet	<input type="checkbox"/>	<input type="checkbox"/>
K-8999	With 1-1/4" O.D. Inlet and 1-1/2" O.D. Outlet ←	<input checked="" type="checkbox"/>	
K-9000	With 1-1/2" O.D. Inlet and 1-1/2" O.D. Outlet	<input type="checkbox"/>	

**PRODUCT SPECIFICATION:**

P-trap shall be of cast brass construction. Adjustable P-trap shall include cleanout plug, and flange. Optional features shall be 1-1/4" or 1-1/2" O.D. slip-joint inlet and 1-1/4" or 1-1/2" O.D. outlet. Product shall be Kohler Model K-\_\_\_\_\_-\_\_\_\_\_.

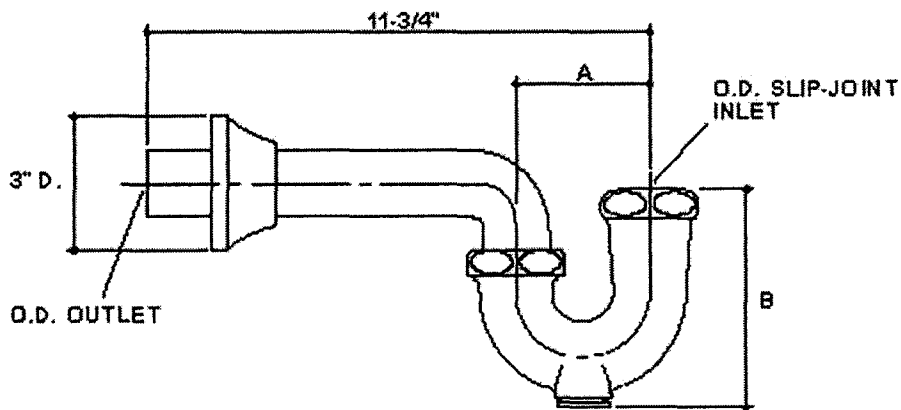

Roughing-In Notes				
	A	B	O.D. OUTLET	O.D. INLET
K-8998	2-3/4'	4-3/8"	1-1/4'	1-1/4"
<b>K-8999</b>	3'	4-7/8"	1-1/2'	1-1/4"
K-9000	3'	4-7/8"	1-1/2'	1-1/2"

14

**PRODUCT DIAGRAM**

**K-8998, K-8999, K-9000** Cast Brass P-Trap  
 Page 2 of 2  
 115170-4-BA (A)





**McGUIRE MFG. CO., INC.**

60 Grandview Court  
 P.O. Box 746 ♣ Cheshire, CT 06410  
 203-699-1801 ♣ Fax 203-699-1813  
 www.mcguiremfg.com

**Part No.**

2165CC, 2165CCLK,  
 2167CC, 2167CCLK

**Product Specification**

Compression x Compression  
 Lavatory Supply

Job Name: \_\_\_\_\_

Submittal Number: \_\_\_\_\_

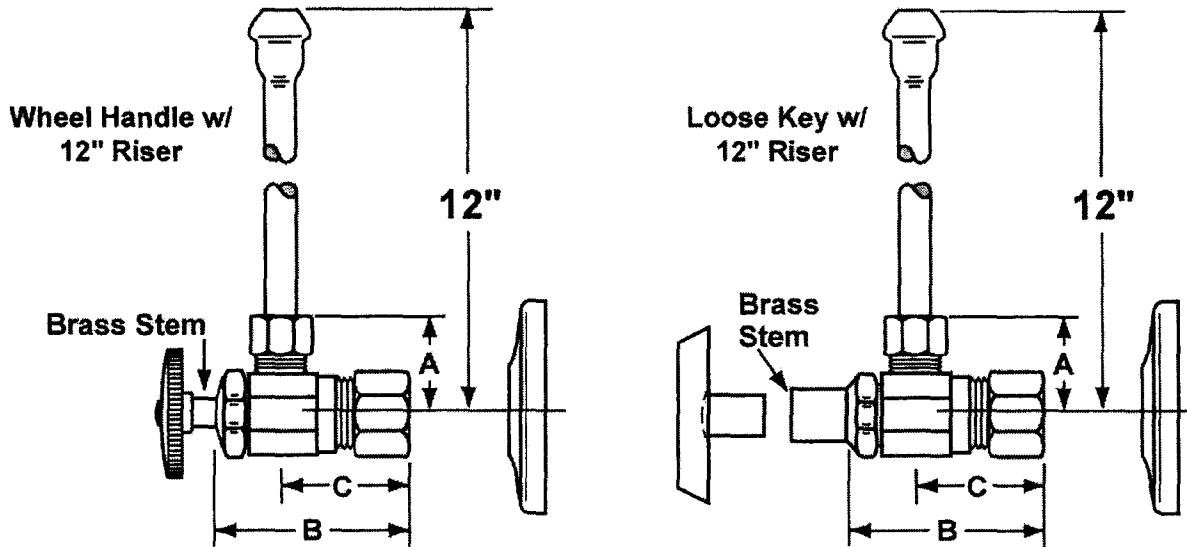

NO.	ROUGHING MEASUREMENTS	A	B	C
2165CC	1/2" Nominal x 3/8" O.D.	1"	1-1/2"	3/4"
2165CCLK	1/2" Nominal x 3/8" O.D.	1"	2-1/4"	3/4"
2167CC	1/2" Nominal x 1/2" O.D.	1"	1-1/2"	3/4"
2167CCLK	1/2" Nominal x 1/2" O.D.	1"	2-1/4"	3/4"

LK designates *Loose Key*



See options and accessories section for details on product variations.

**Specifications:**

Supply kit shall include chrome plated brass stops with full turn brass stem, no plastic, (12, 15, 20) inch chrome plated copper risers and (shallow, deep, bell) (steel, brass) or (forged brass with set screw) flange. Inlet shall be (3/8, 1/2) inch (IPS, sweat, compression). Outlet shall be (3/8, 1/2) inch (IPS, compression). Supply kit shall be McGuire \_\_\_\_\_. Supply kit shall be certified by CSA or other recognized testing authority and bear manufacturer and testing mark. Stop to be certified to 200 psi line pressure.

**SUBMITTAL SHEET**

**PRODUCT DESCRIPTION**

LAV GUARD waste and supply piping covers satisfy all ADA compliance requirements with its unique and universal design, allowing for easy installation over virtually all tubular and cast brass P-p assemblies, as well as angle valve and supply tube assemblies, regardless of their geometry or rotational offset. Smooth, flush Snap Clip™ fasteners firmly secure piping covers in place.

**SAMPLE SPECIFICATIONS**

Handicap lavatory P-trap and angle valve assemblies shall be covered with the soft, antimicrobial, **LAV GUARD**, piping cover manufactured by **TRUEBRO, Inc.** Model # \_\_\_\_\_, Accessory # \_\_\_\_\_, color \_\_\_\_\_ (white or grey). Piping cover shall be secured with Snap Clip™ flush mounted fasteners. Angle stop valve shall be secured with locking lid access cover. Cover shall be non-yellowing and fire retardant.



**UNDERSINK PROTECTIVE PIPE COVERS**

**DESIGN FEATURES**

- Universal design fits virtually all lavatory applications
- Antimicrobial vinyl maintains sanitary conditions
- Lock Lid™ on valve stops tampering & allows service
- Cleanout nut cap allows service on trap without disassembly
- Snap-Clip™ fastener is flush, nonabrasive & reusable
- Internal ribs enhance K value & soften impact cushioning

**LAV GUARD Kits Fit:**

- All P-trap assemblies, cast brass or tubular - 1 1/4" or 1 1/2".
- All straight tail piece assemblies - 1 1/4" or 1 1/2".
- All standard 5 1/2" offset wheelchair strainers. (Acc. #105)
- All angle stop valves - handled or keyed type 3/8" or 1/2".

\*NOTE: LAV GUARD Kits will not fit Schedule 40 plastic P-traps.

**Models Available: White or Grey**  
Select model and color.

- **Model #99**     white     grey  
One angle valve and supply cover only.
- **Model #100**     white     grey  
One P-trap cover only.
- **Model #101**     white     grey  
One P-trap cover, one angle valve and supply cover.
- **Model #102**     white     grey  
One P-trap cover, two angle valve and supply covers.
- **Model #103**     white     grey  
One P-trap cover, two angle valve and supply covers, one offset tailpiece wheelchair strainer cover. (Acc. #105)
- **Accessory #105**     white     grey  
One offset tailpiece wheelchair strainer cover only.

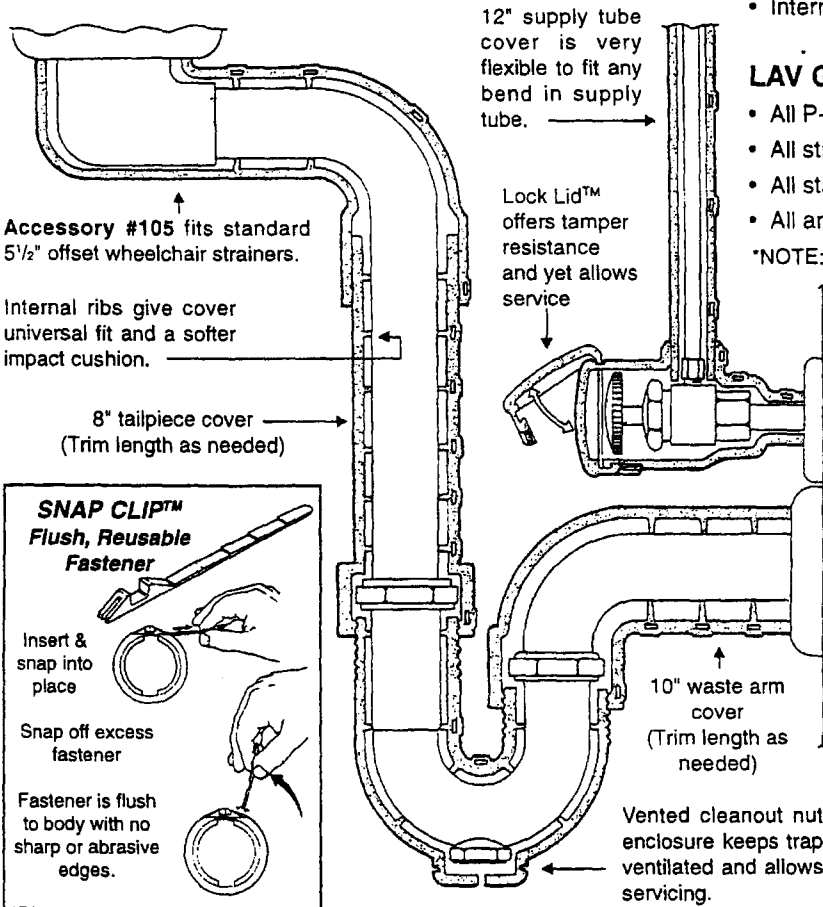

Approved By: \_\_\_\_\_



TRUEBRO, Inc.  
7 Main Street • Ellington, CT 06029  
(203) 875-2868 • 1-800-340-5969  
Fax: (203) 872-0300

<b>MATERIAL:</b>	MOLDED CLOSED CELL VINYL
<b>NOM. WALL:</b>	1/8 INCH CONSTANT
<b>DUROMETER:</b>	55 - 65 - SHORE A
<b>UV PROTECTION:</b>	WILL NOT FADE OR DISCOLOR
<b>DURABILITY:</b>	VIRTUALLY INDESTRUCTIBLE
<b>FASTENERS:</b>	SNAP-CLIP™, FLUSH, REUSABLE
<b>COLOR:</b>	LIGHT GREY OR WHITE
<b>PAINTABILITY:</b>	APPLY ACRYLIC ENAMEL
<b>BURNING CHARACTERISTICS</b>	SELF-EXTINGUISHED
<b>ASTM D 635:</b>	5 SEC (ATB) 10 MM (AEB)
<b>THERMAL CONDUCTIVITY</b>	BTU - IN/HR - FT² - °F
<b>ASTM C 177:</b>	K VALUE = 1.17
<b>BACTERIA/FUNGUS RESIST:</b>	ANTIMICROBIAL VINYL FORMULA
<b>MAINTENANCE:</b>	USE COMMON DETERGENTS



**Z-1231** ←  
**CONCEALED ARM SYSTEM**  
**WALL LAVATORIES**

SPECIFICATION SHEET

TAG \_\_\_\_\_

Dimensional Data (inches and [ mm ]) are Subject to Manufacturing Tolerances and Change Without Notice

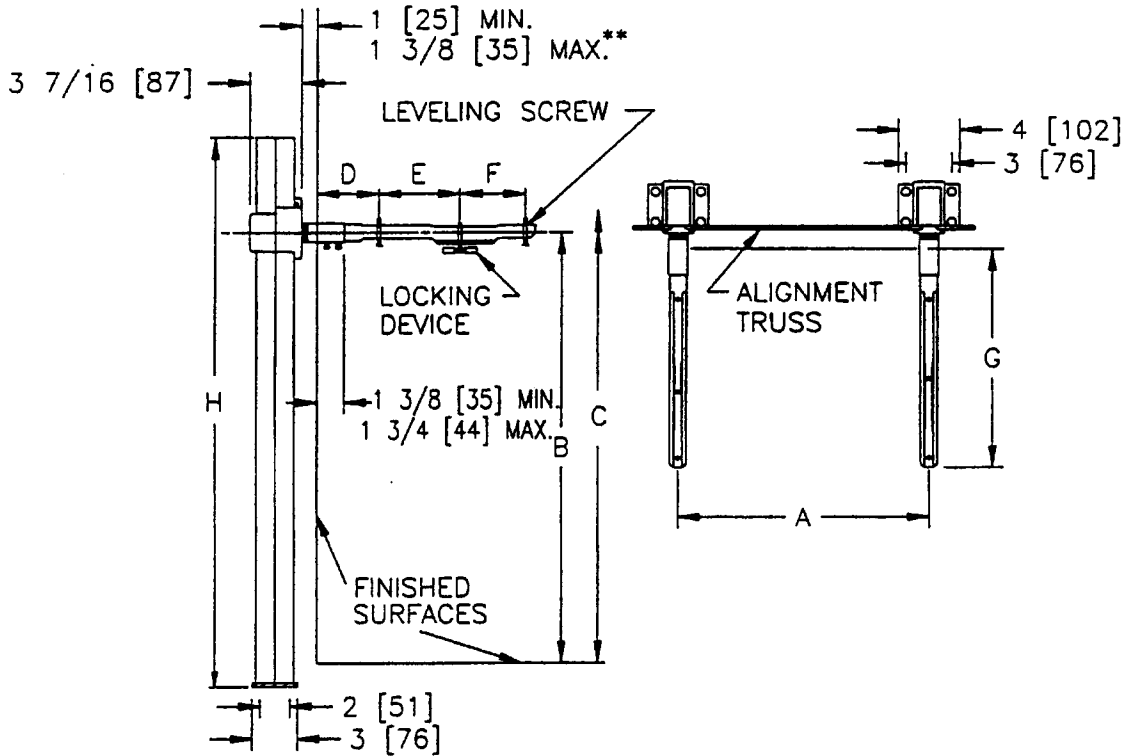

\*\* WITH STANDARD SLEEVE LENGTH OF 3 1/4 [83].

Product No.	Approx. Wt. Lbs. [kg]
Z-1231	45 [20]

**ENGINEERING SPECIFICATION:** ZURN Z-1231 Lavatory support system with concealed arms. Complete with Dura-Coated rectangular steel uprights with welded feet, cast iron adjustable headers, concealed arms, steel sleeves, alignment truss, and mounting fasteners.

**OPTIONS** (Check/specify appropriate options)

**PREFIXES**

\_\_\_ Z- Dura-Coated System with Support Plate\*

**SUFFIXES**

- \_\_\_ -AL Adapter Lug
- \_\_\_ -CU Floor to Ceiling Upright (Specify Height Required)
- \_\_\_ -D Back to Back System
- \_\_\_ -E2 Concealed Arm Escutcheons 2 [51] Long
- \_\_\_ -E4 Concealed Arm Escutcheons 4 [102] Long
- \_\_\_ -E6 Concealed Arm Escutcheons 6 [152] Long
- \_\_\_ -SL Stud Length Over 3 1/4 [82] (Specify Length)
- \_\_\_ -WS Wall Support Valve Plate (Specify Valve Name and Number)
- \_\_\_ -79 Paraplegic Rough-in

REV. DATE: 03/21/95 C.N. NO. 71133

DWG. NO. 58855 PRODUCT NO. Z-1231

\*REGULARLY FURNISHED UNLESS OTHERWISE SPECIFIED

ZURN INDUSTRIES, INC. • HYDROMECHANICS DIV., • 1801 Pittsburgh Ave. • Erie, PA 16514 • Phone: 814/455-0921 Fax: 814/454-7929  
 In Canada: ZURN INDUSTRIES LIMITED • 6540 Gottardo Court • Mississauga, Ontario L5T 2A2 • Phone: 905/795-8844 Fax: 905/795-8850



**CHESAPEAKE™**

**WALL-MOUNT LAVATORY**

**K-1722, K-1724,  
K-1728**

**ADA**

**FEATURES**

- 19-1/4"(48.9cm) x 17-1/4"(43.8cm)
- Vitreous china
- Ledge-back
- 8"(20.3cm) centers (K-1724), 4"(10.2cm) centers (K-1728) or single-hole (K-1722)
- With overflow
- ADA compliant
- With hanger
- Drilled for concealed arm carrier

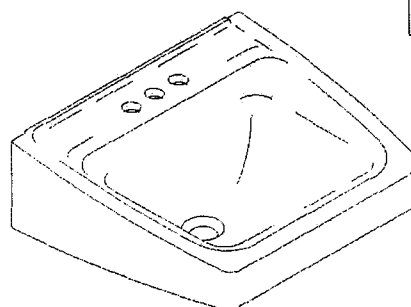

**CODES/STANDARDS APPLICABLE**

Specified model meets or exceeds the following:

- ADA
- ASME/ANSI A112.19.2M
- CABO/ANSI A117.1
- IAPMO/UPC
- State of Massachusetts

**COLORS/FINISHES**

- 0 White
- Other Refer to Fixtures Price Book for additional colors

**Accessories:**

- CP Polished Chrome
- Other Refer to Faucets Price Book for additional finishes

**SPECIFIED MODEL:**

Model	Description	Colors/Finishes	
K-1724	8" (20.3cm) centers lavatory	<input type="checkbox"/> 0 White	<input type="checkbox"/> Other _____
K-1728	4" (10.2cm) centers lavatory ←	<input checked="" type="checkbox"/> 0 White	<input type="checkbox"/> Other _____
K-1722	Single-hole lavatory	<input type="checkbox"/> 0 White	<input type="checkbox"/> Other _____
Recommended Accessories			
K-8998	Trap	<input type="checkbox"/> CP	<input type="checkbox"/> Other _____

**PRODUCT SPECIFICATION:**

The lavatory shall be 19-1/4" (48.9cm) in length, and 17-1/4" (43.8cm) in width. Lavatory shall be made of vitreous china. Lavatory shall be ledge-back with hanger. Lavatory shall have 8" (20.2cm) centers (K-1724), 4" (10.2cm) centers (K-1728), or single-hole (K-1722) drilling. Lavatory shall be drilled for concealed arm carrier. Lavatory shall have overflow. Lavatory shall be ADA compliant. Lavatory shall be Kohler Model K-\_\_\_\_\_.

*We reserve the right to make revisions without notice in the design of fixtures or in packaging unless this right has specifically been waived at the time the order is accepted.*

Page 1 of 2  
105028-4-CB

# CHESAPEAKE™

## PRODUCT INFORMATION

ADA compliant.			
Fixture*:		basin area	water depth
Lavatory		14" (35.6cm) x 11" (27.9cm)	4-7/8" (12.4cm)
Drain hole	1-3/4" D. (4.4cm)		
* Approximate measurements for comparison only.			
Holes	<b>K-1724</b>	<b>K-1728</b>	<b>K-1722</b>
Spout	1-3/8" D. (3.5cm)	1-1/4" D. (3.2cm)	1-3/8" D. (3.5cm)
Faucet	1-3/8" D. (3.5cm)	1-1/4" D. (3.2cm)	
Soap dispenser			1-1/4" D. (3.2cm)
Included Components:			
Hanger			64839

## INSTALLATION NOTES

Install this product according to the installation guide. Fixture dimensions are nominal and conform to tolerances in ASME Standard A112.19.2M. Concealed arm carrier required, **NOT** supplied by Kohler Co. Supplied hanger not used with concealed arm carrier.

### CONCEALED ARM HOLE LOCATIONS

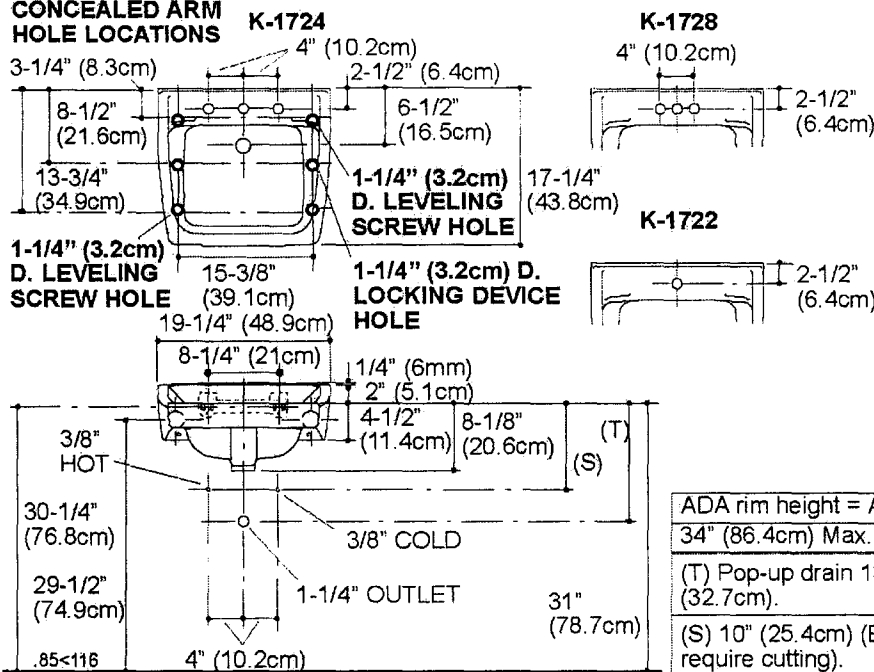

STANDARD INSTALLATION

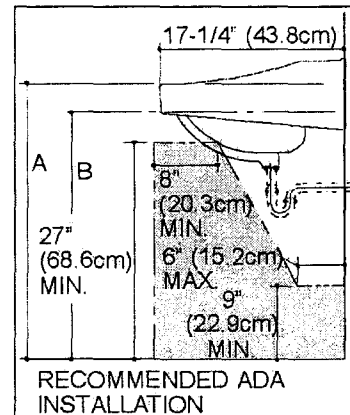

ADA rim height = A	ADA arm carrier height = B
34" (86.4cm) Max.	33" (81.9cm) Max.
(T) Pop-up drain 13-3/4" (34.9cm), grid drain 12-7/8" (32.7cm).	
(S) 10" (25.4cm) (Based on 12" (30.5cm) riser which may require cutting).	

## PRODUCT DIAGRAM

K-1722, K-1724, K-1728 Chesapeake™ Lavatory  
 Page 2 of 2  
 105028-4-CB

THE BOLD LOOK  
 OF **KOHLER**®



# McGUIRE MFG. CO., INC.

60 Grandview Court  
P.O. Box 746 ♣ Cheshire, CT 06410  
203-699-1801 ♣ Fax 203-699-1813

## Product Specification

### Part No.

155WC

Offset Lavatory  
Grid Strainer

Job Name:

Submittal Number:

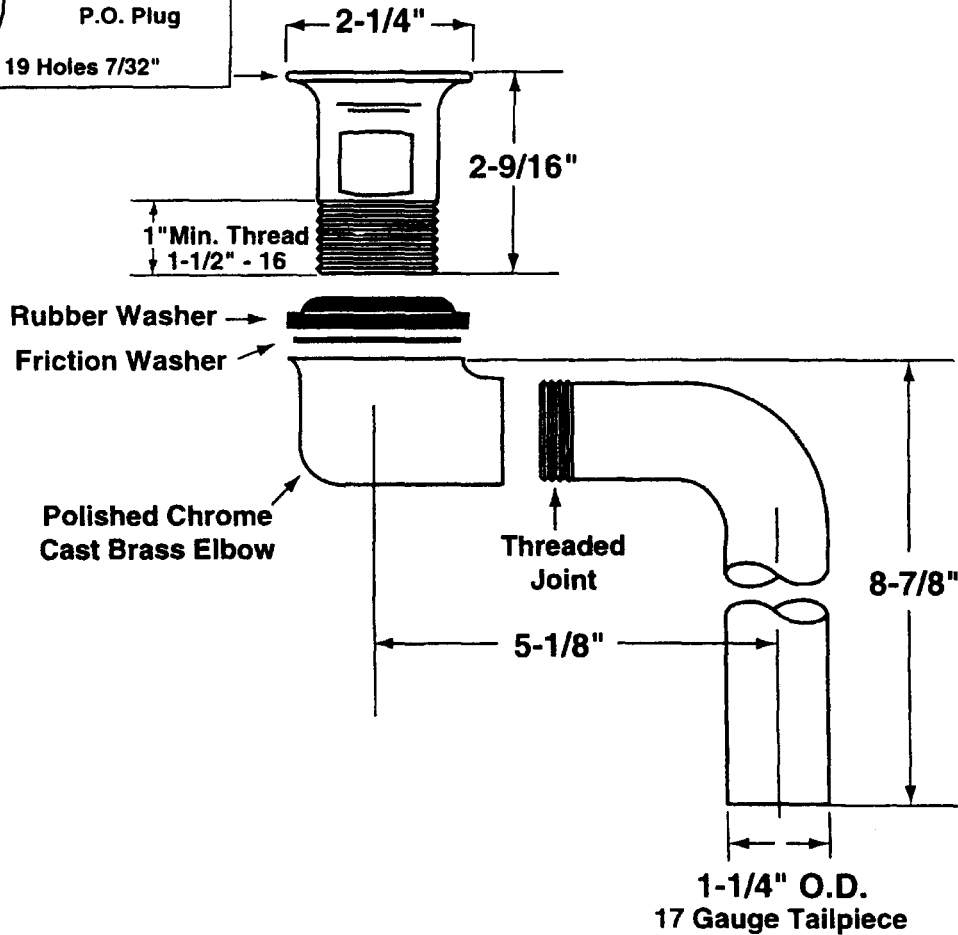
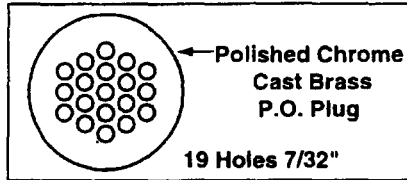

A.D.A.



CSA Certified

See accessories section for details on product variations.

### Specifications:

Cast Brass Chrome Plated Offset Wheelchair Strainer with polished chrome cast brass elbow, 17 gauge 1-1/4 inch seamless brass offset tailpiece, heavy rubber basin washer and fiber friction washer. Offset lavatory strainer shall be in compliance with CSA or other recognized testing authority and bear both manufacturer and testing mark.



**FEATURES**

- Cast brass construction
- Adjustable rotation on tube outlet
- Slip-joint inlet
- Cleanout plug
- Flange

**P-TRAP**  
**K-8998**  
 ALSO K-8999, K-9000

**CODES/STANDARDS APPLICABLE**

Specified model meets or exceeds the following:

- ASME/ANSI A112.18.1M
- IAPMO/UPC

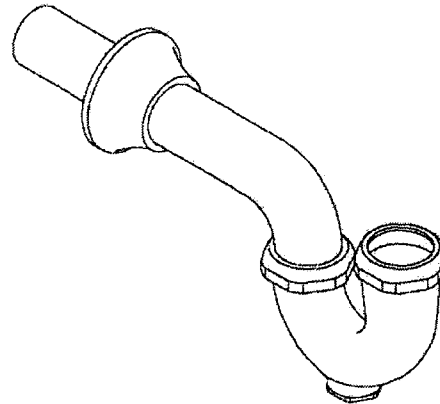

**COLORS/FINISHES**

- CP Polished Chrome
- Other Refer to Faucets Price Book for additional finishes

**SPECIFIED MODEL:**

Model	Description	<input type="checkbox"/> CP	<input type="checkbox"/> Other _____
K-8998	With 1-1/4" O.D. Inlet and 1-1/4" O.D. Outlet	<input type="checkbox"/>	<input type="checkbox"/>
K-8999	With 1-1/4" O.D. Inlet and 1-1/2" O.D. Outlet	<input checked="" type="checkbox"/>	<input type="checkbox"/>
K-9000	With 1-1/2" O.D. Inlet and 1-1/2" O.D. Outlet	<input type="checkbox"/>	<input type="checkbox"/>

**PRODUCT SPECIFICATION:**

P-trap shall be of cast brass construction. Adjustable P-trap shall include cleanout plug, and flange. Optional features shall be 1-1/4" or 1-1/2" O.D. slip-joint inlet and 1-1/4" or 1-1/2" O.D. outlet. Product shall be Kohler Model K-\_\_\_\_\_-\_\_\_\_\_-.

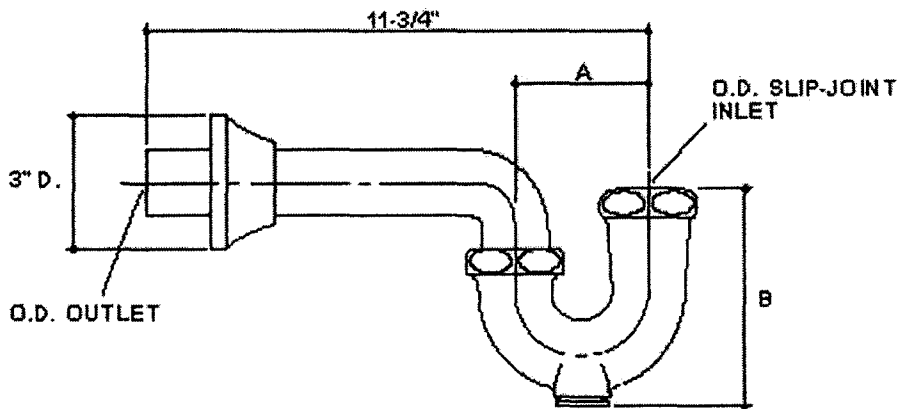

Roughing-In Notes				
	A	B	O.D. OUTLET	O.D. INLET
K-8998	2-3/4"	4-3/8"	1-1/4"	1-1/4"
<b>K-8999</b>	3"	4-7/8"	1-1/2"	1-1/4"
K-9000	3"	4-7/8"	1-1/2"	1-1/2"

14

PRODUCT DIAGRAM

K-8998, K-8999, K-9000 Cast Brass P-Trap  
 Page 2 of 2  
 115170-4BA (A)





**McGUIRE MFG. CO., INC.**

60 Grandview Court  
 P.O. Box 746 ♣ Cheshire, CT 06410  
 203-699-1801 ♣ Fax 203-699-1813  
 www.mcguiremfg.com

**Part No.**

2165CC, 2165CCLK,  
 2167CC, 2167CCLK

**Product Specification**

Compression x Compression  
 Lavatory Supply

Job Name: \_\_\_\_\_

Submittal Number: \_\_\_\_\_

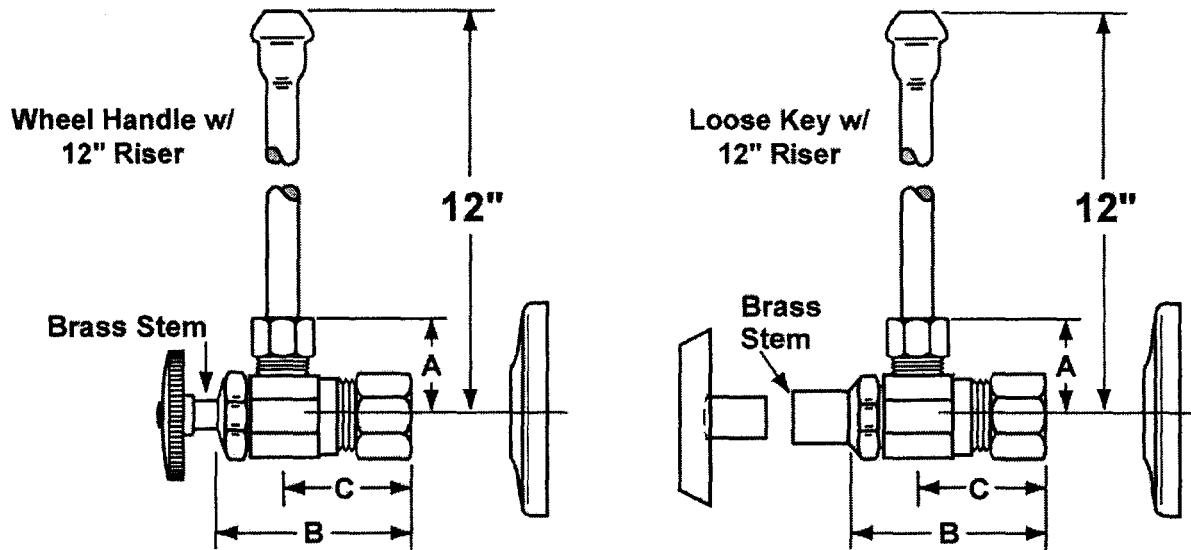

NO.	ROUGHING MEASUREMENTS	A	B	C
2165CC	1/2" Nominal x 3/8" O.D.	1"	1-1/2"	3/4"
2165CCLK	1/2" Nominal x 3/8" O.D.	1"	2-1/4"	3/4"
2167CC	1/2" Nominal x 1/2" O.D.	1"	1-1/2"	3/4"
2167CCLK	1/2" Nominal x 1/2" O.D.	1"	2-1/4"	3/4"

LK designates *Loose Key*



See options and accessories section for details on product variations.

**Specifications:**

Supply kit shall include chrome plated brass stops with full turn brass stem, no plastic, (12, 15, 20) inch chrome plated copper risers and (shallow, deep, bell) (steel, brass) or (forged brass with set screw) flange. Inlet shall be (3/8, 1/2) inch (IPS, sweat, compression). Outlet shall be (3/8, 1/2) inch (IPS, compression). Supply kit shall be McGuire \_\_\_\_\_. Supply kit shall be certified by CSA or other recognized testing authority and bear manufacturer and testing mark. Stop to be certified to 200 psi line pressure.

**SUBMITTAL SHEET**

**PRODUCT DESCRIPTION**

LAV GUARD waste and supply piping covers satisfy all ADA compliance requirements with its unique and universal design, allowing for easy installation over virtually all tubular and cast brass P-trap assemblies, as well as angle valve and supply tube assemblies, regardless of their geometry or rotational offset. Smooth, flush Snap Clip™ fasteners firmly secure piping covers in place.

**SAMPLE SPECIFICATIONS**

Handicap lavatory P-trap and angle valve assemblies shall be covered with the soft, antimicrobial, **LAV GUARD**, piping cover manufactured by **TRUEBRO, Inc.** Model # \_\_\_\_\_, Accessory # \_\_\_\_\_, color \_\_\_\_\_ (white or grey). Piping cover shall be secured with Snap Clip™ flush mounted fasteners. Angle stop valve shall be secured with locking lid access cover. Cover shall be non-yellowing and fire retardant.



**UNDERSINK PROTECTIVE PIPE COVERS DESIGN FEATURES**

- Universal design fits virtually all lavatory applications
- Antimicrobial vinyl maintains sanitary conditions
- Lock Lid™ on valve stops tampering & allows service
- Cleanout nut cap allows service on trap without disassembly
- Snap-Clip™ fastener is flush, nonabrasive & reusable
- Internal ribs enhance K value & soften impact cushioning

**LAV GUARD Kits Fit:**

- All P-trap assemblies, cast brass or tubular - 1 1/4" or 1 1/2".
- All straight tail piece assemblies - 1 1/4" or 1 1/2".
- All standard 5 1/2" offset wheelchair strainers. (Acc. #105)
- All angle stop valves - handed or keyed type 3/8" or 1/2".

\*NOTE: LAV GUARD Kits will not fit Schedule 40 plastic P-traps.

**Models Available: White or Grey**  
Select model and color.

- **Model #99**  white  grey  
One angle valve and supply cover only.
- **Model #100**  white  grey  
One P-trap cover only.
- **Model #101**  white  grey  
One P-trap cover, one angle valve and supply cover.
- **Model #102**  white  grey  
One P-trap cover, two angle valve and supply covers.
- **Model #103**  white  grey  
One P-trap cover, two angle valve and supply covers, one offset tailpiece wheelchair strainer cover. (Acc. #105)
- **Accessory #105**  white  grey  
One offset tailpiece wheelchair strainer cover only.

Approved By: \_\_\_\_\_



TRUEBRO, Inc.  
7 Main Street • Ellington, CT 06029  
(203) 875-2868 • 1-800-340-5969  
Fax: (203) 872-0300

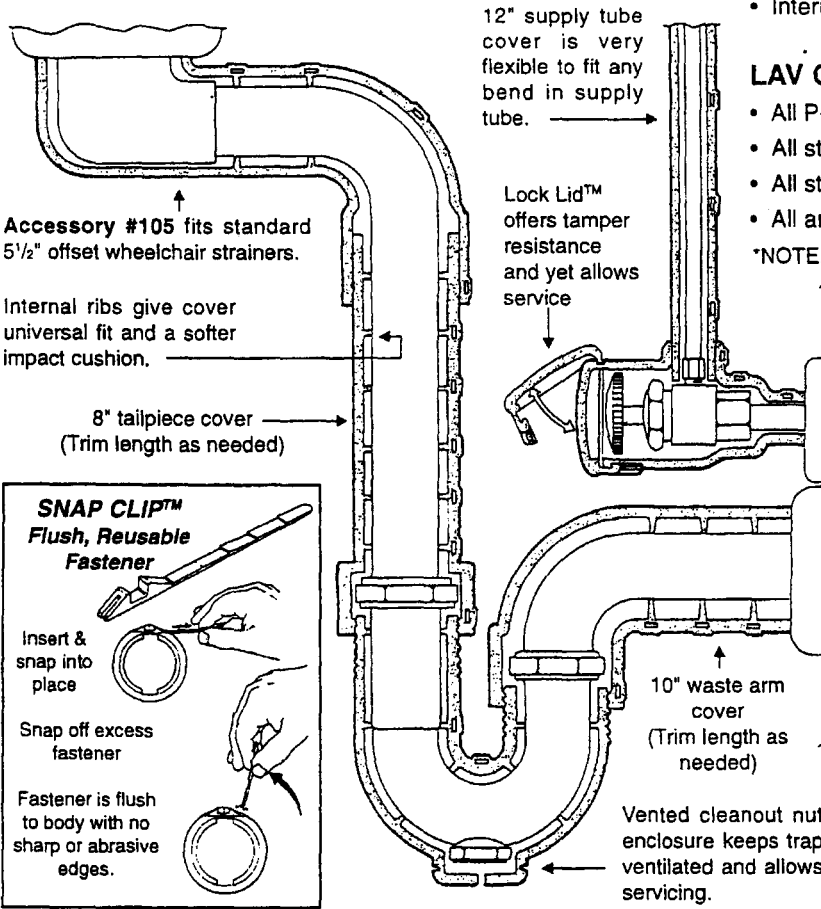

<b>MATERIAL:</b>	MOLDED CLOSED CELL VINYL
<b>NOM. WALL:</b>	1/8 INCH CONSTANT
<b>DUROMETER:</b>	55 - 65 - SHORE A
<b>UV PROTECTION:</b>	WILL NOT FADE OR DISCOLOR
<b>DURABILITY:</b>	VIRTUALLY INDESTRUCTIBLE
<b>FASTENERS:</b>	SNAP-CLIP™, FLUSH, REUSABLE
<b>COLOR:</b>	LIGHT GREY OR WHITE
<b>PAINTABILITY:</b>	APPLY ACRYLIC ENAMEL
<b>BURNING CHARACTERISTICS</b>	SELF-EXTINGUISHED
<b>ASTM D 635:</b>	5 SEC (ATB) 10 MM (AEB)
<b>THERMAL CONDUCTIVITY</b>	BTU - IN/HR - FT <sup>2</sup> - °F
<b>ASTM C 177:</b>	K VALUE = 1.17
<b>BACTERIA/FUNGUS RESIST:</b>	ANTIMICROBIAL VINYL FORMULA
<b>MAINTENANCE:</b>	USE COMMON DETERGENTS



**Z-1231**  
**CONCEALED ARM SYSTEM**  
**WALL LAVATORIES**

SPECIFICATION SHEET

TAG \_\_\_\_\_

Dimensional Data (inches and [ mm ]) are Subject to Manufacturing Tolerances and Change Without Notice

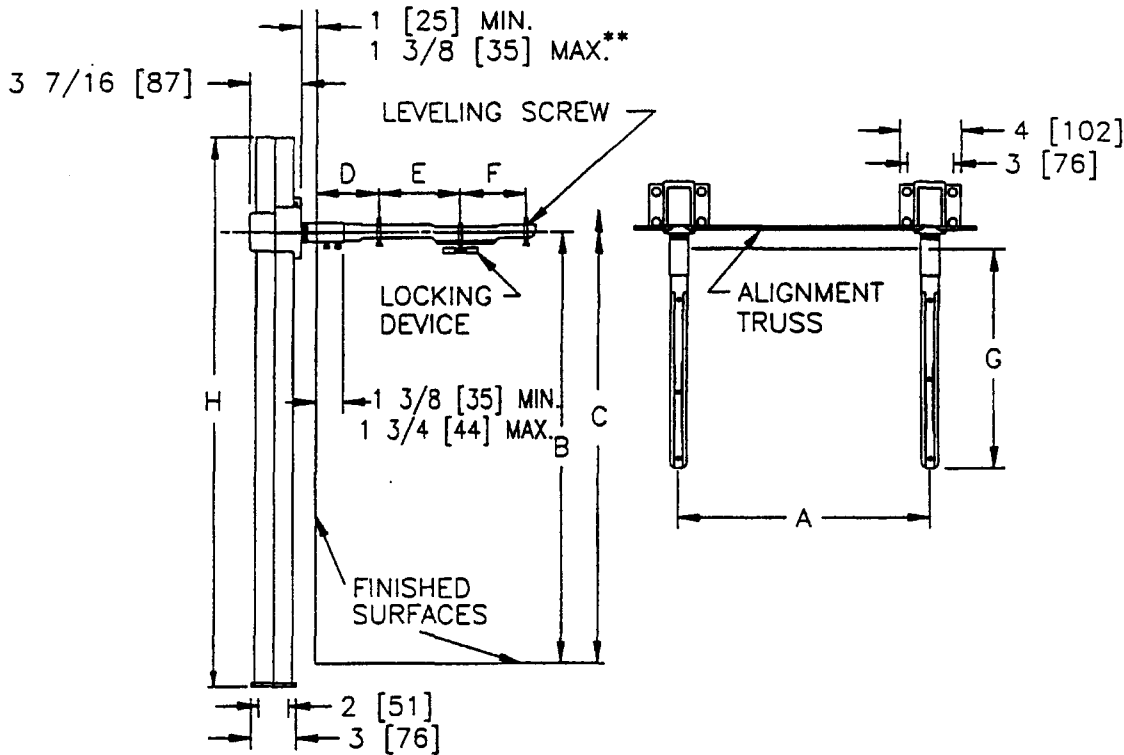

\*\* WITH STANDARD SLEEVE LENGTH OF 3 1/4 [83].

Product No.	Approx. Wt. Lbs. [kg]
Z-1231	45 [20]

**ENGINEERING SPECIFICATION:** ZURN Z-1231 Lavatory support system with concealed arms. Complete with Dura-Coated rectangular steel uprights with welded feet, cast iron adjustable headers, concealed arms, steel sleeves, alignment truss, and mounting fasteners.

**OPTIONS** (Check/specify appropriate options)

**PREFIXES**

\_\_\_ Z- Dura-Coated System with Support Plate\*

**SUFFIXES**

- \_\_\_ -AL Adapter Lug
- \_\_\_ -CU Floor to Ceiling Upright (Specify Height Required)
- \_\_\_ -D Back to Back System
- \_\_\_ -E2 Concealed Arm Escutcheons 2 [51] Long
- \_\_\_ -E4 Concealed Arm Escutcheons 4 [102] Long
- \_\_\_ -E6 Concealed Arm Escutcheons 6 [152] Long
- \_\_\_ -SL Stud Length Over 3 1/4 [82] (Specify Length)
- \_\_\_ -WS Wall Support Valve Plate (Specify Valve Name and Number)
- \_\_\_ -79 Paraplegic Rough-in

REV.	DATE: 03/21/95	C.N. NO. 71133
DWG. NO. 58855	PRODUCT NO. Z-1231	

\*REGULARLY FURNISHED UNLESS OTHERWISE SPECIFIED

**KOHLER®**

**DEXTER™**

**URINAL**

**K-5016-ET**

**ADA**

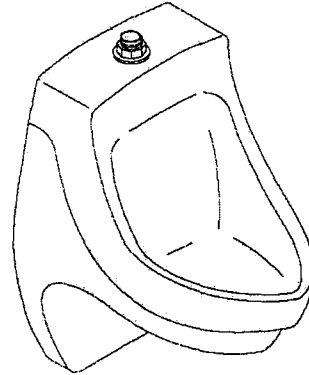

**FEATURES**

- Vitreous china
- Siphon jet
- 3/4" top spud
- 14-1/2" (36.8cm) extended rim
- Includes inlet & outlet spuds and hangers
- Includes anti-backsplash wall
- 1.0 gallon (3.78L) or less flush
- ADA compliant when rim is mounted no higher than 17" (43.2cm) from finished floor

**CODES/STANDARDS APPLICABLE**

Specified model meets or exceeds the following:

- ADA when rim is mounted no higher than 17" (43.2cm) from finished floor
- ASME/ANSI A112.19.2M
- ASME/ANSI A112.19.6M
- CABO/ANSI A117.1
- IAPMO/UPC
- Energy Policy Act of 1992 (EPACT)
- States of Massachusetts, New York, & Texas
- City of Los Angeles, CA

**COLORS/FINISHES**

- 0 White
- Other Refer to Fixtures Price Book for additional colors

**SPECIFIED MODEL:**

Model	Description	Colors/Finishes
K-5016-ET	3/4" top spud urinal	<input checked="" type="checkbox"/> 0 White <input type="checkbox"/> Other _____

**PRODUCT SPECIFICATION:**

The siphon jet urinal shall be made of vitreous china with a 3/4" top spud. Urinal shall have 14-1/2" (36.8cm) extended rim. Urinal shall include inlet & outlet spuds and hangers. Urinal shall include anti-backsplash wall. Urinal shall be 1.0 gallon (3.78L) or less flush. Urinal shall be ADA compliant when rim is mounted no higher than 17" (43.2cm) from finished floor. Urinal shall be Kohler Model K-5016-ET-\_\_\_\_\_.

We reserve the right to make revisions without notice in the design of fixtures or in packaging unless this right has specifically been waived at the time the order is accepted.

Page 1 of 2  
116345-4- AC

# DEXTER <sup>112</sup>

## PRODUCT INFORMATION

ADA compliant.	
Fixture:	
Configuration	Top spud
Spud inlet size	3/4"
Gallons per flush	< 1 gallon* (3.78L)
*Designed to flush with less than one gallon (3.78L) of water when installed with a water saving flush valve.	
Included Components:	
3/4" inlet spud	18376
2" outlet spud	18766
Hanger (2 required)	64512
Flush valve requirements: Refer to manufacturer's instructions and local codes.	

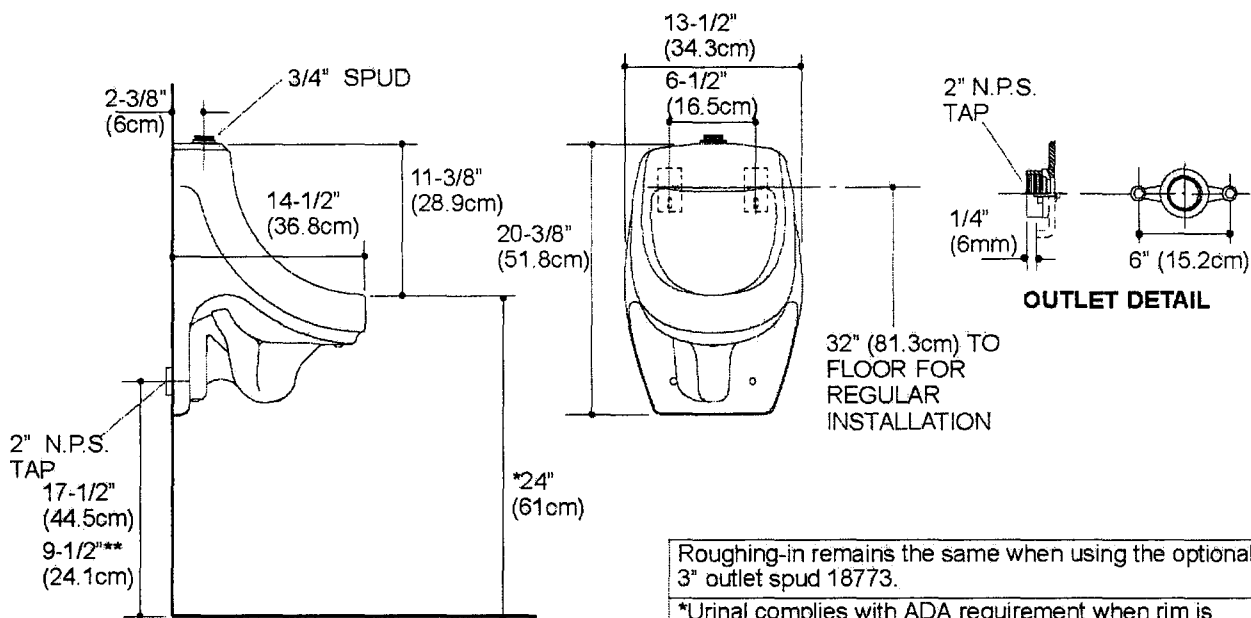

Roughing-in remains the same when using the optional 3" outlet spud 18773.  
 \*Urinal complies with ADA requirement when rim is mounted no higher than 17" (43.2cm) from finished floor.  
 \*\*Outlet height for ADA compliance.

1.25>116

## PRODUCT DIAGRAM

### Features

- KOHLER cast iron
- Acid resistant enamel finish
- Single compartment
- With rim guard
- 2-hole (K-6714 and K-6716)
- Drilled back (K-6714 and K-6716) or blank back (K-6718 and K-6719)

### SERVICE SINK K-6714

ALSO K-6716, K-6718, K-6719

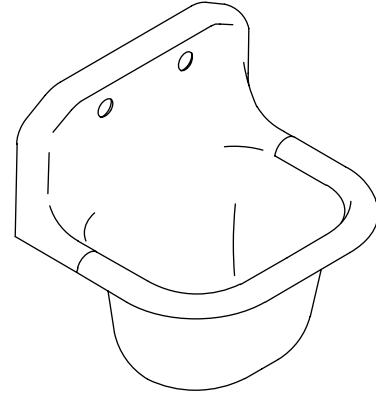

### Codes/Standards Applicable

Specified model meets or exceeds the following:

- IAPMO/UPC
- ASME A112.19.1M
- CSA B45

### Colors/Finishes

- 0: White

#### Accessories:

- CP: Polished Chrome
- RP: Rough Plate
- NA: None applicable

### Specified Model

Model	Description	Colors/Finishes
K-6714	22-1/4" (56.5 cm) x 18-1/4" (46.4 cm) drilled back service sink	<input type="checkbox"/> 0 White
K-6716	24" (61 cm) x 20-1/4" (51.4 cm) drilled back service sink	<input type="checkbox"/> 0 White
K-6718	22-1/4" (56.5 cm) x 18-1/4" (46.4 cm) blank back service sink	<input type="checkbox"/> 0 White
K-6719	24" (61 cm) x 20-1/4" (51.4 cm) blank back service sink	<input type="checkbox"/> 0 White

#### Recommended Accessories

K-6672	Trap for 2" (5 cm) iron pipe	<input type="checkbox"/> NA
K-6673	Trap for 3" (7.6 cm) iron pipe	<input type="checkbox"/> NA
K-8905	Knoxford™ faucet for K-6714 and K-6716 sinks	<input type="checkbox"/> CP <input type="checkbox"/> RP
K-8906	Knoxford™ faucet for K-6718 and K-6719 sinks	<input type="checkbox"/> CP <input type="checkbox"/> RP
K-8907	Kinlock™ faucet for K-6714 and K-6716 sinks	<input type="checkbox"/> CP <input type="checkbox"/> RP
K-8908	Kinlock™ faucet for K-6718 and K-6719 sinks	<input type="checkbox"/> CP <input type="checkbox"/> RP

### Product Specification:

The service sink shall be 22-1/4" (56.5 cm) in length and 18-1/4" (46.4 cm) in width, or 24" (61 cm) in length and 20-1/4" (51.4 cm) in width. Sink shall be made of cast iron with acid resistant enamel finish. Sink shall be single compartment with drilled back (K-6714 and K-6716) or blank back (K-6718 and K-6719). Sink shall have a rim guard. Sink shall be Kohler Model K-\_\_\_\_\_-0.

# BANNON™

## Technical Information

Fixture*:	basin area	water depth
Sink (K-6714 and K-6718)	18" (45.7 cm) x 14" (35.6 cm)	12" (30.5 cm)
Sink (K-6716 and K-6719)	20" (50.8 cm) x 16" (40.6 cm)	12" (30.5 cm)
Drain hole	2-7/8" (7.3 cm) D.	
Faucet holes	1-1/2" (3.8 cm) D.	
Rim guard holes	5/8" (1.6 cm) D.	
* Approximate measurements for comparison only.		

Included Components:	
Hangers	64515
Stainless steel rim guard (K-6714 and K-6718)	44603
Stainless steel rim guard (K-6716 and K-6719)	44602

## Installation Notes

Install this product according to the installation guide.

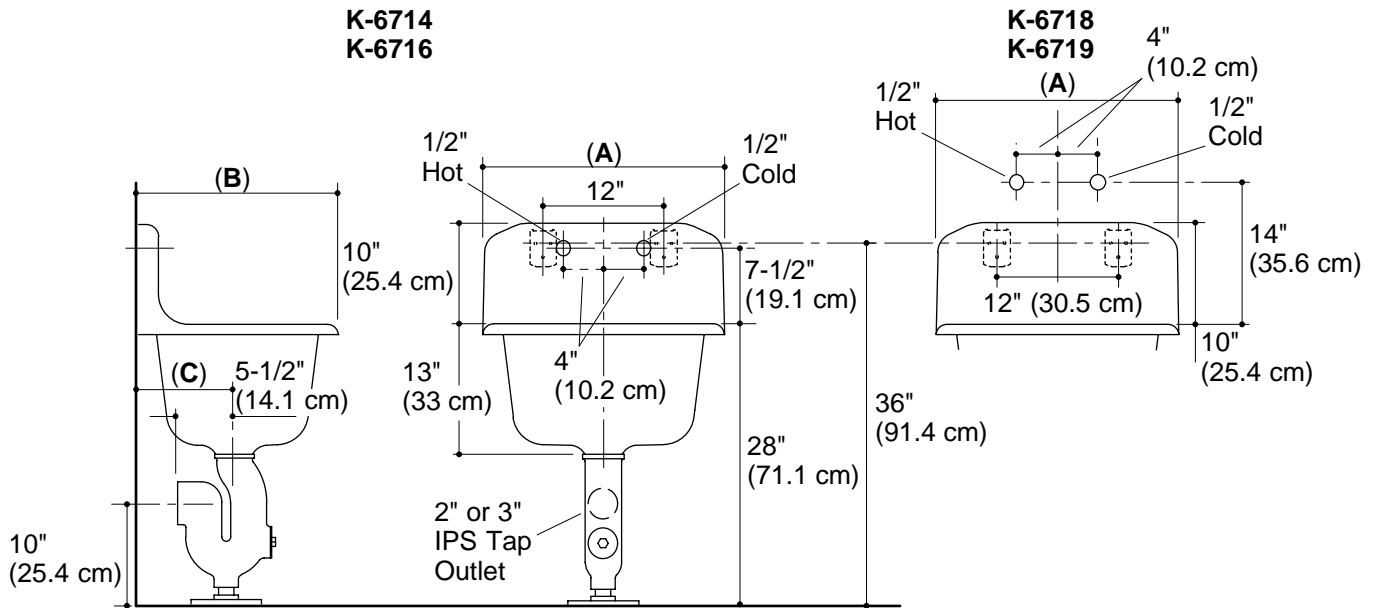

	(A)	(B)	(C)
<b>K-6714, K-6718</b>	22-1/4" (56.5 cm)	18-1/4" (46.4 cm)	8-1/2" (21.6 cm)
<b>K-6716, K-6719</b>	24" (61 cm)	20-1/4" (51.4 cm)	9-1/2" (24.1 cm)

## Product Diagram



**Z-1221**  
**PLATE TYPE SYSTEM**  
**WALL URINALS**

SPECIFICATION SHEET

TAG \_\_\_\_\_

Dimensional Data (inches and [ mm ]) are Subject to Manufacturing Tolerances and Change Without Notice

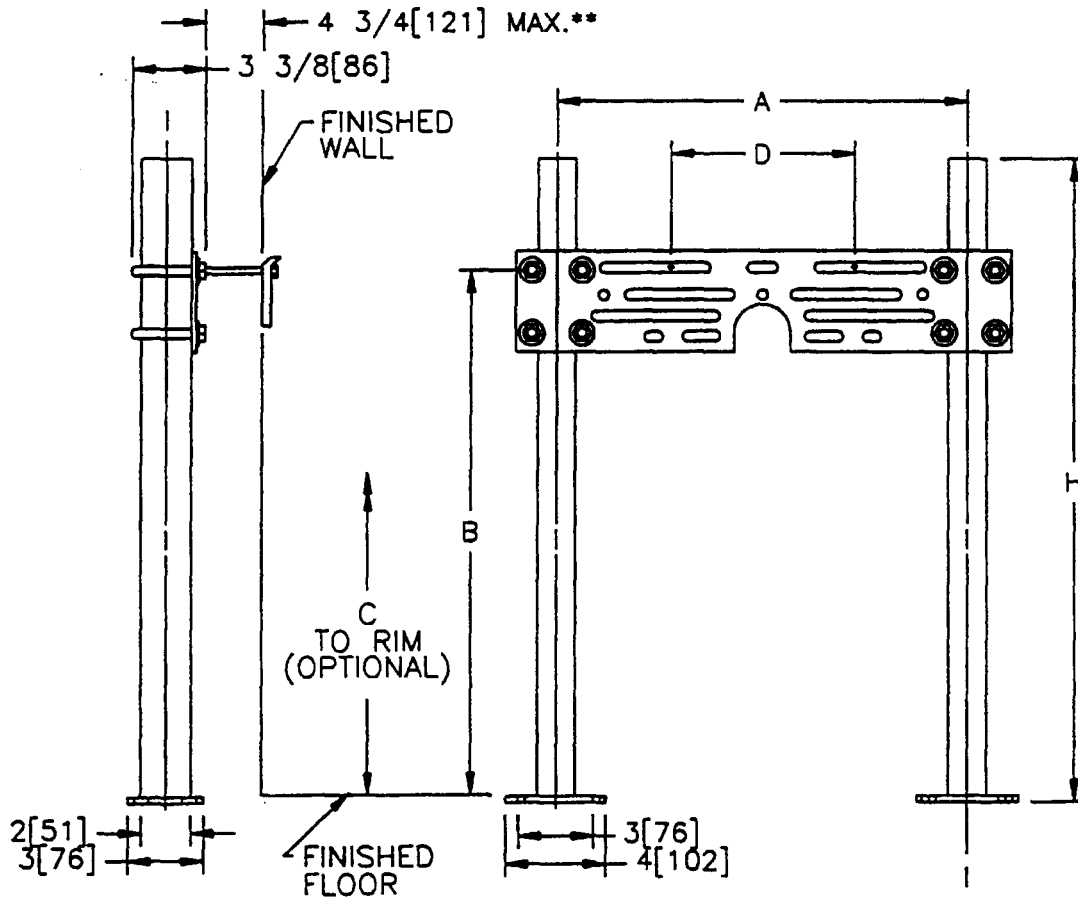

\*\* WITH STANDARD STUD LENGTH OF 6 [152]

Product No.	Approx. Wt. Lbs. [kg]
Z-1221	50 [23]

**ENGINEERING SPECIFICATION:** ZURN Z-1221 Wall urinal support system with top support plate. Complete with Dura-Coated rectangular steel uprights with welded feet, adjustable support plate, and mounting fasteners.

OPTIONS (Check/specify appropriate options)

**PREFIXES**

\_\_\_ Z- Dura-Coated System with Universal Plate\*

**SUFFIXES**

- \_\_\_ -CU Floor to Ceiling Upright
- \_\_\_ -D Back to Back System
- \_\_\_ -SL Stud Length Greater Than 6 [152] (Specify Length)
- \_\_\_ -58 Flush Valve Supply Support for Urinals

REV.	DATE: 03/21/95	C.N. NO. 71127
DWG. NO. 58849		PRODUCT NO. Z-1221

\*REGULARLY FURNISHED UNLESS OTHERWISE SPECIFIED



**SINK STRAINER  
K-9115  
ALSO K-9118**

**FEATURES**

- Brass construction
- Intended for sink installations with 2" outlet
- Perforated strainer
- Brass tailpiece

**CODES/STANDARDS APPLICABLE**

Specified model meets or exceeds the following:

- ASME/ANSI A112.18.1M

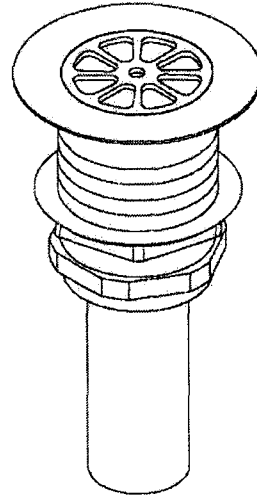

**COLORS/FINISHES**

- CP Polished Chrome

**SPECIFIED MODEL:**

Model	Description	
K-9115	With 1-1/2" O.D. Tailpiece	<input checked="" type="checkbox"/> CP
K-9118	With 2" O.D. Tailpiece	<input type="checkbox"/> CP

**PRODUCT SPECIFICATION:**

Sink strainer shall be of brass construction. Product shall feature perforated strainer, cast brass body, and brass tailpiece. Product is intended for sink installations with 2" outlet. Optional feature shall be 1-1/2" O.D. or 2" O.D. tailpiece. Strainer shall be Kohler Model K-\_\_\_\_\_-CP.

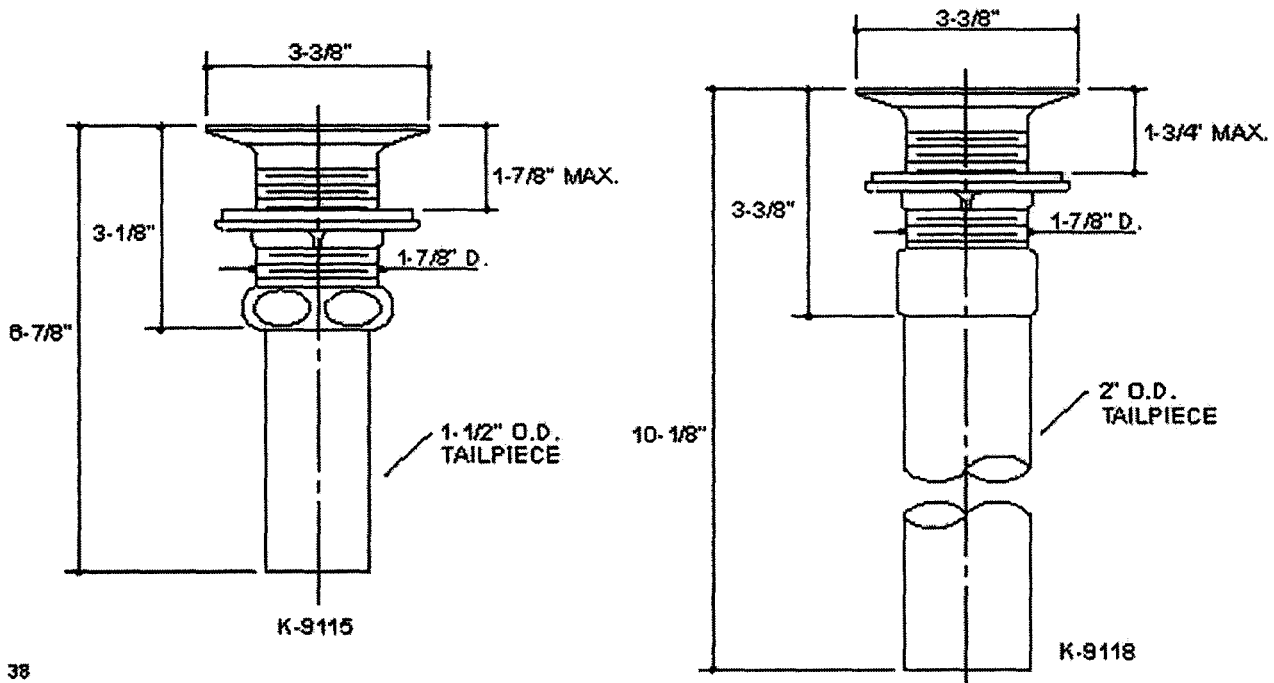

38

PRODUCT DIAGRAM

K-9115, K-9118 Sink Strainers  
Page 2 of 2  
115179-4-BA (A)



### SINK SUPPLY FAUCET **K-7853** ALSO K-7855, K-7856

ADA

#### Features

- Brass construction
- Brass valve bodies
- Valvet® valves
- Rotating spout
- For 8" (20.3 cm) centers
- Cross and lever handles are ADA compliant
- Optional soap dish
- Inside threaded couplings
- Available with 8" (20.3 cm) or 12" (30.5 cm) spout reach
- Available with ADA compliant cross or lever handles
- 2.2 gpm (8.3 lpm) maximum flow rate

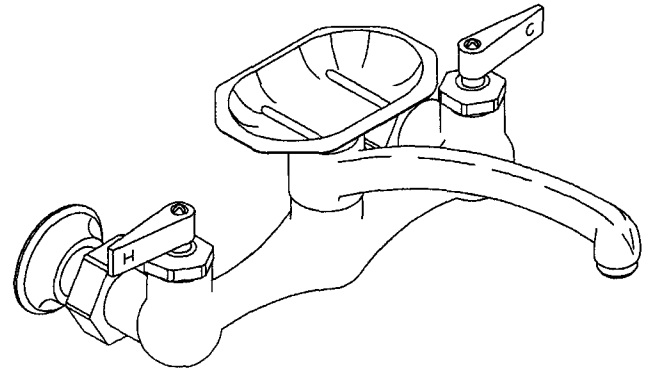

#### Codes/Standards Applicable



Specified model meets or exceeds the following at date of manufacture:

- ADA
- ASME A112.18.1/CSA B125.1
- ICC/ANSI A117.1
- NSF 61
- Energy Policy Act of 1992
- All applicable US Federal and State material regulations

#### Colors/Finishes

- CP: Polished Chrome
- Other: Refer to Price Book for additional colors/finishes

#### Specified Model

Model	Description	 ADA		 ADA	
		<input type="checkbox"/> CP	<input type="checkbox"/> Other_____	<input type="checkbox"/> CP	<input type="checkbox"/> Other_____
K-7853	Sink supply faucet – 8" (20.3 cm) spout reach and lever handles, less soap dish	<input type="checkbox"/> CP	<input type="checkbox"/> Other_____		
K-7855-3	Sink supply faucet – 8" (20.3 cm) spout reach and cross handles, with soap dish			<input type="checkbox"/> CP	<input type="checkbox"/> Other_____
K-7855-4	Sink supply faucet – 8" (20.3 cm) spout reach and lever handles, with soap dish	<input checked="" type="checkbox"/> CP	<input type="checkbox"/> Other_____		
K-7856-3	Sink supply faucet – 12" (30.5 cm) spout reach and cross handles, with soap dish			<input type="checkbox"/> CP	<input type="checkbox"/> Other_____
K-7856-4	Sink supply faucet – 12" (30.5 cm) spout reach and lever handles, with soap dish	<input type="checkbox"/> CP	<input type="checkbox"/> Other_____		

#### Product Specification

The two-handle sink supply faucet shall be of brass construction and brass valve bodies. Product shall feature Valvet valves, inside threaded couplings, and a rotating spout. Product shall be for 8" (20.3 cm) centers. Product shall be available with a 8" (20.3 cm) or 12" (30.5 cm) spout reach. Product shall be available with cross handles or lever handles which are ADA compliant. Product shall have optional soap dish. Faucet shall be Kohler Model K-\_\_\_\_-\_\_\_\_-\_\_\_\_.

# CLEARWATER®

## Installation Notes

Install this product according to the installation guide.

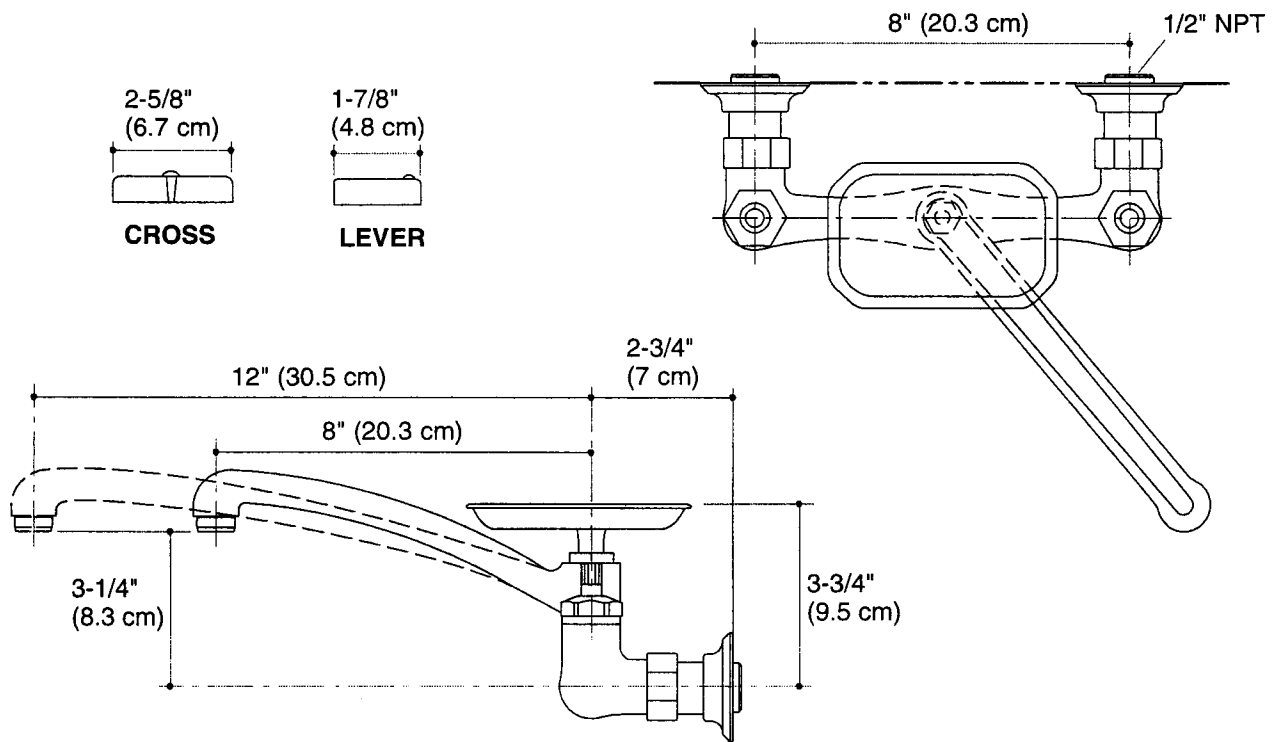

**Product Diagram**

**For Health Hazard Applications**

Job Name \_\_\_\_\_  
 Job Location \_\_\_\_\_  
 Engineer \_\_\_\_\_  
 Approval \_\_\_\_\_

Contractor \_\_\_\_\_  
 Approval \_\_\_\_\_  
 Contractor's P.O. No. \_\_\_\_\_  
 Representative \_\_\_\_\_

**Series 909**  
**Reduced Pressure Zone Assemblies**  
**Sizes: 2½" – 10" (65–250mm)**

Series 909 Reduced Pressure Zone Assemblies are designed to provide cross-connection control protection of the potable water supply in accordance with national plumbing codes. This series can be utilized in a variety of installations, including health hazard cross-connections in plumbing systems or for containment at the service line entrance. With its exclusive patented relief valve design incorporating the "air-in/water-out" principle, it provides substantially improved relief valve discharge performance during the emergency conditions of combined backsiphonage and backpressure with both checks fouled.

**Features**

- Replaceable bronze seats
- Stainless steel internal parts
- No special tools required for servicing
- Captured spring check assemblies
- Fused epoxy coated & lined checks
- Industrial strength sensing hose
- Field reversible relief valve
- Air-in/water-out relief valve design provides maximum capacity during emergency conditions

**Available Models**

Suffix:

- BB – bronze body (2½", 3" only) (64, 76mm)
- LF – without shutoff valves
- NRS – non-rising stem resilient seated gate valves
- OSY - UL/FM outside stem & yoke resilient seated gate valves
- QT-FDA – FDA epoxy coated quarter-turn ball valves
- S – cast iron strainer
- S-FDA – FDA epoxy coated strainer

**Note:** The installation of a drain line is recommended. When installing a drain line, an air gap is necessary.

**Specifications**

A Reduced Pressure Zone Assembly shall be installed at each cross-connection to prevent backsiphonage and backpressure backflow of hazardous materials into the potable water supply. The assembly shall consist of a pressure differential relief valve located in a zone between two positive seating check valves and captured springs. Backsiphonage protection shall include provision to admit air directly into the reduced pressure zone via a separate channel from the water discharge channel. The assembly shall include two tightly closing shutoff valves before and after the valve and test cocks. The assembly shall meet the requirements of ASSE Std. 1013; AWWA Std. C511-92; CSA B64.5; and UL Classified File No. EX3185. Listed by IAPMO (UPC). Approved by the Foundation for Cross-Connection Control and Hydraulic Research at the University of Southern California. The assembly shall be a Watts Regulator Company Series 909.

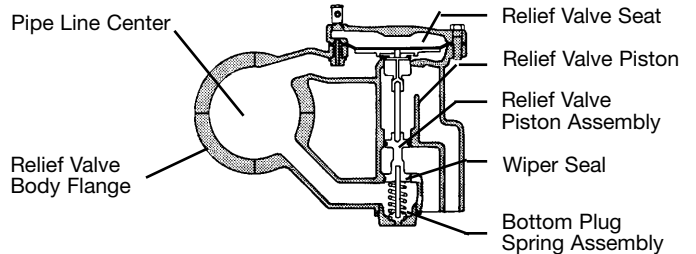
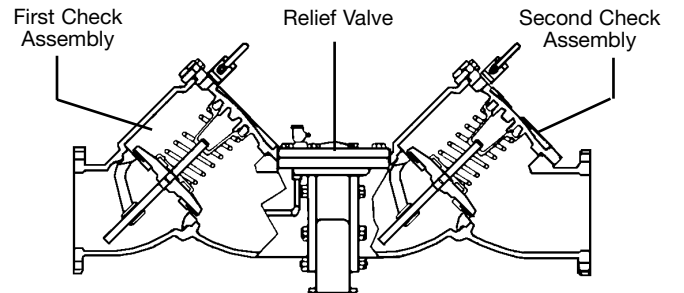
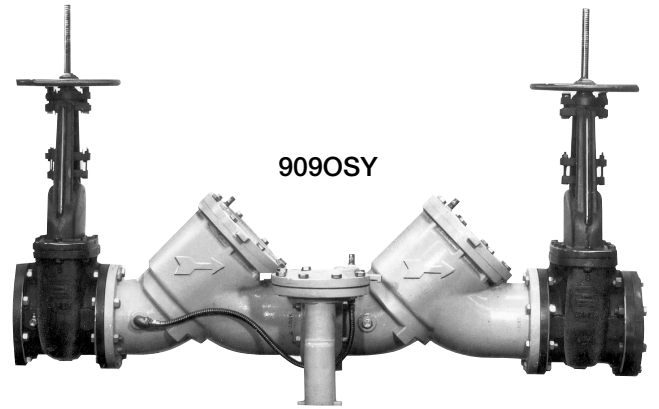

**Now Available**  
**WattsBox Insulated Enclosures.**  
 For more information, send for literature ES-WB.

**IMPORTANT: INQUIRE WITH GOVERNING AUTHORITIES  
 FOR LOCAL INSTALLATION REQUIREMENTS**



Watts product specifications in U.S. customary units and metric are approximate and are provided for reference only. For precise measurements, please contact Watts Technical Service. Watts reserves the right to change or modify product design, construction, specifications, or materials without prior notice and without incurring any obligation to make such changes and modifications on Watts products previously or subsequently sold.

## Materials

Check Valve Bodies: FDA epoxy coated cast iron or bronze  
 Seats: bronze  
 Trim: stainless steel  
 Relief Valve Body: 2½"-3" (60-80mm) bronze  
 4"-10" (100-250mm) FDA epoxy coated cast iron  
 Test Cocks: bronze body ball valve

## Pressure — Temperature

Temperature Range: 33°F-110°F (5°C-43°C) continuous,  
 140°F (60°C) intermittent  
 Maximum Working Pressure: 175psi (12.06 bar)

## Standards

AWWA C511-92  
 IAPMO PS 31, SBCCI (Standard Plumbing Code)  
 USC manual for Cross-Connection Control, 8th Edition

## How It Operates

The unique relief valve construction incorporates two channels: one for air, one for water. When the relief valve opens, as in the accompanying air-in/water-out diagram, the right-hand channel admits air to the top of the reduced pressure zone, relieving the zone vacuum. The channel on the left then drains the zone to atmosphere. Therefore, if both check valves foul, and simultaneous negative supply and positive backpressure develops, the relief valve uses the air-in/water-out principle to stop potential backflow.

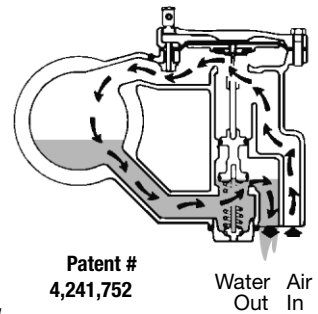

## Approvals



Approved by the Foundation for Cross-Connection Control and Hydraulic Research at the University of Southern California.

## Capacity

\*Typical maximum flow rate (7.5 feet/sec.)

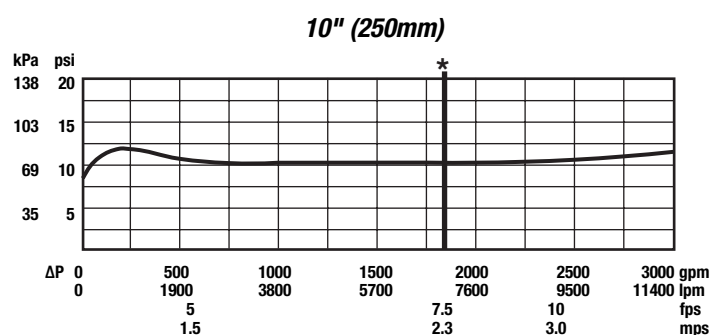
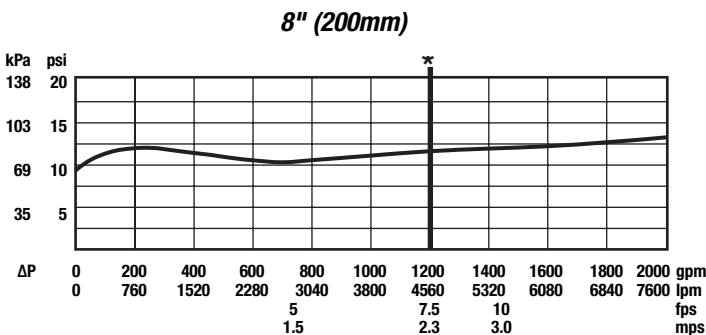
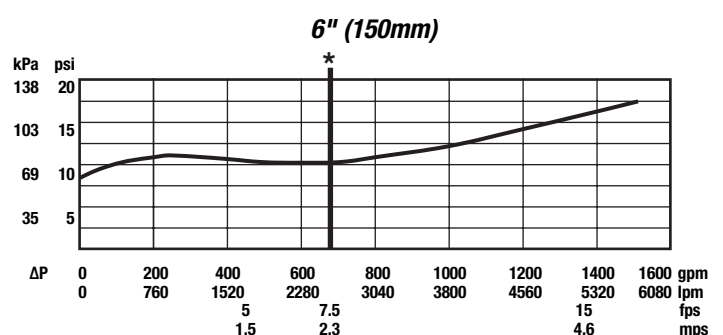
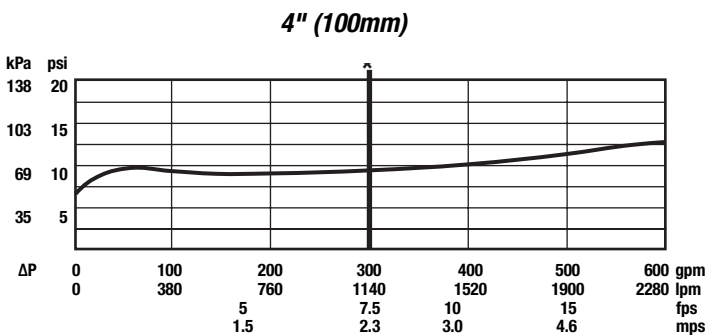
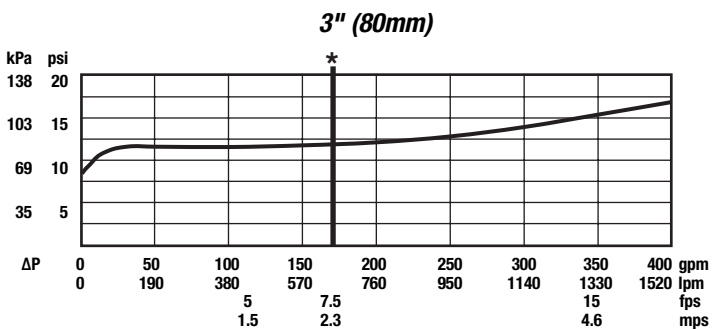
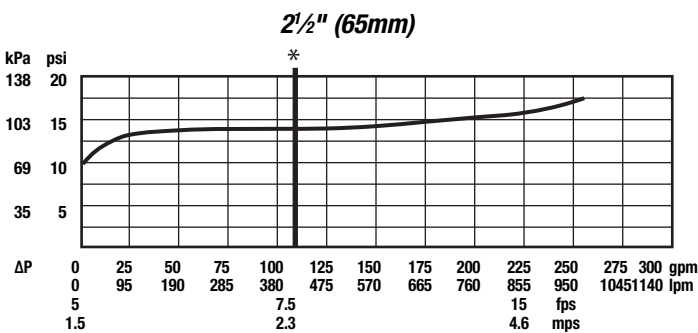

## Dimensions – Weights

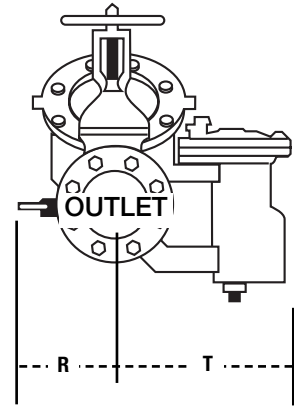
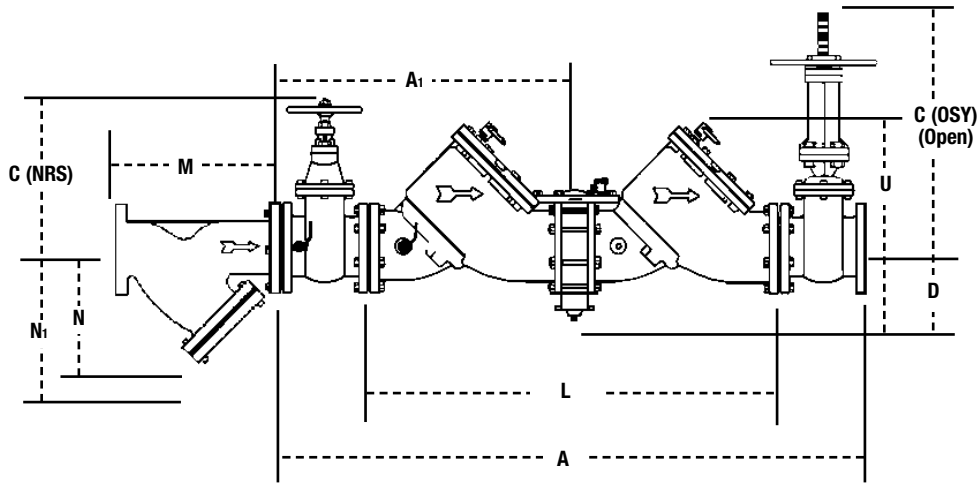

Quarter-turn (QT) Valve

Watts G-4000 Series  
Ball Valves  
Send for F-G4000

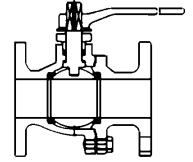

NOTE: Valve may be furnished with (2) OSY or (2) NRS Shutoffs.

NOTE: Relief valve section is reversible, therefore, can be on either side and is furnished standardly as shown.

SIZE (DN)		DIMENSIONS										WEIGHT															
in.	mm	A		A1		C		D	L	clearance for check U	R	R (QT)	T	NRS	OSY	QT											
		in.	mm	in.	mm	(OSY)*	(NRS)										in.	mm	in.	mm	in.	mm	lbs.	kgs.	lbs.	kgs.	lbs.
2½	65	41¼	1048	20¾	524	16¾	416	9¾	238	5¼	133	26¾	663	11	279	4	102	16	406	9¼	230	195	88.4	198	89.8	182	82.6
3	80	42¼	1073	21¼	540	18¾	479	10¼	260	5¼	133	26¾	663	11	279	5	127	16	406	9¼	230	225	102	230	104	190	86
4	100	55½	1400	27¾	702	22¾	578	12¾	310	6	152	37	940	14	356	6	152	19¾	502	14¾	365	455	206	470	213	352	160
6	150	65½	1664	32¾	832	30¾	765	16	406	6	152	44½	1130	16	406	11	279	26	660	14¾	365	718	326	798	362	762	346
8	200	78½	2000	39¾	1000	37¾	959	19½	506	9¾	248	55¼	1403	21	533	11¼	286	11¼	286	19¼	489	1350	612	1456	660	2286	1037
10	250	93¾	2378	46¾	1190	45¼	1162	23¼	605	9¾	248	67¾	1711	21	533	12½	318	12½	318	21	533	2160	980	2230	1011	3716	1685

\*UL, FM approved backflow preventers must include UL/FM approved OSY gate valves.

## Strainer Dimensions

SIZE (DN)		DIMENSIONS				WEIGHT			
in.	mm	M		N1†	N	lbs.	kgs.		
		in.	mm	in.	mm			in.	mm
2½	65	10	254	10	254	6½	165	28	12.7
3	80	10½	257	10	254	7	178	34	15.4
4	100	12½	308	12	305	8¼	210	60	27
6	150	18½	470	20	508	13½	343	133	60
8	200	21¾	549	22¾	578	15½	394	247	112
10	250	26	660	28	711	18½	470	370	168

† – Dimension required for screen removal

## Air Gap Dimensions

When installing a drain line on Series 909 backflow preventers that are installed horizontally, use 909 AG series air gaps.

Iron Body Model No.	Ordering Code	Series/Sizes	DIMENSIONS			WEIGHT				
			A	B	C	lbs	kgs			
			in.	mm	in.	mm	in.	mm		
909AG-F	0881378	1¼" – 3" 009/909								
		1¼" – 2" 009 M1	4¾	111	6¾	171	2	51	3.25	1.47
		2" 009 M2								
909AG-K	0881385	4" – 6" 909	6¾	162	9¾	244	3	76	6.25	2.83
		8" – 10" 909 M1								
909AG-M	0881387	8" – 10" 909	7¾	187	11¼	286	4	102	15.50	7.03

For flange size backflow preventers installed vertically (flow down), a fabricated air gap is recommended.

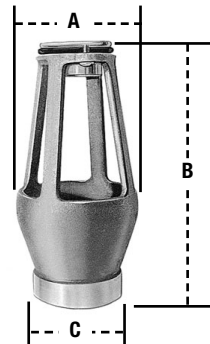

For additional information, visit our website at: [www.watts.com](http://www.watts.com)



**Backflow Prevention Products**

ES-909L 0815



**USA:** 815 Chestnut St., No. Andover, MA 01845-6098; [www.watts.com](http://www.watts.com)  
**Canada:** 5435 North Service Rd., Burlington, ONT. L7L 5H7; [www.wattscanada.ca](http://www.wattscanada.ca)

© Watts Regulator Company, 2008

**For Health Hazard Applications**

Job Name \_\_\_\_\_  
 Job Location \_\_\_\_\_  
 Engineer \_\_\_\_\_  
 Approval \_\_\_\_\_

Contractor \_\_\_\_\_  
 Approval \_\_\_\_\_  
 Contractor's P.O. No. \_\_\_\_\_  
 Representative \_\_\_\_\_

# Series 909

## Reduced Pressure Zone Assemblies

**909 Sizes: 3/4", 1" (20, 25mm)**  
**909M1 Sizes: 1 1/4", 1 1/2", 2" (32, 40, 50mm)**

Series 909 Reduced Pressure Zone Assemblies are designed to provide superior cross-connection control protection of the potable water supply in accordance with national plumbing codes and containment control for water authority requirements. This series can be utilized in a variety of installations, including health hazard cross-connections in plumbing systems or for containment at the service line entrance. With its exclusive design incorporating the patented "air-in/water-out" principle it provides maximum relief valve discharge during the emergency conditions of combined backsiphonage and backpressure with both checks fouled. Model 909QT, standardly furnished with full port, resilient seated and bronze ball valve shutoffs. Sizes 3/4" and 1" (20 and 25mm) shutoffs have tee handles.

### Features

- Modular design
- Replaceable seats
- Compact for installation ease
- Horizontal or vertical (up or down) installation
- No special tools required for servicing

### Specifications

A Reduced Pressure Zone Assembly shall be installed at each cross-connection to prevent backsiphonage and backpressure of hazardous materials into the potable water supply. The assembly shall consist of a pressure differential relief valve located in a zone between two positive seating check valves. Backsiphonage protection shall include provision to admit air directly into the reduced pressure zone via a separate channel from the water discharge channel, or directly into the supply pipe via a separate vent. The assembly shall include two tightly closing shutoff valves before and after the assembly, test cocks and a protective strainer upstream of the No. 1 shutoff valve. The assembly (specify Model 909 for temperatures up to 140°F (60°C) or Model 909HW for temperatures up to 210°F (99°C)) shall meet the requirements of ASSE Std. 1013; AWWA Std. C-511-92 CSA B64.4; FCCCHR of USC Manual Section 10. Listed by IAPMO (UPC). SBCCI (Standard Plumbing code). The assembly shall be a Watts Regulator Company Series 909QTS or 909QTSHW.

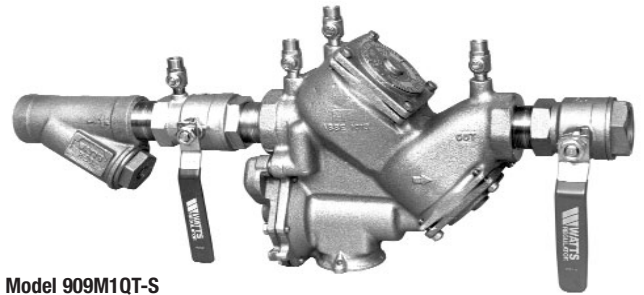

**Model 909M1QT-S**  
**1 1/2" (40mm)**

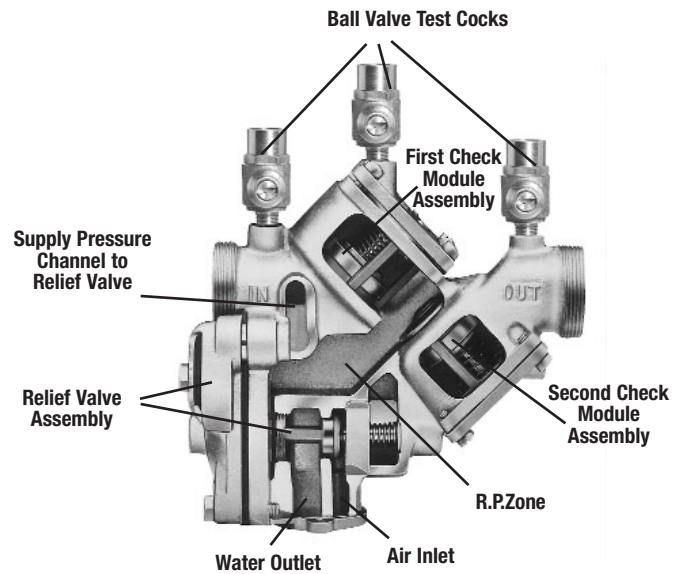

**Now Available**  
**WattsBox Insulated Enclosures.**  
 For more information, send for literature ES-WB.

Watts product specifications in U.S. customary units and metric are approximate and are provided for reference only. For precise measurements, please contact Watts Technical Service. Watts reserves the right to change or modify product design, construction, specifications, or materials without prior notice and without incurring any obligation to make such changes and modifications on Watts products previously or subsequently sold.



## Models

### Suffix

C&T	Cap and tether test cocks
PC	Internal polymer coating
QT	Quarter-turn ball valves
S	Bronze strainer
HW	Stainless steel check modules for hot and harsh water conditions
LF	Without shutoff valves
LH	Locking ball valve handles (open position)
HC	Inlet/outlet fire hydrant fitting (2" only)

### Prefix

C	Clean and check strainer - ¾" and 1" (20 and 25mm) only
U	Union - ¾" and 1" (20 and 25mm) only
FAE	Flanged adapter ends - 1¼", 1½", 2" (32, 40, 50mm) only

NOTE: The installation of a drain line is recommended. When installing a drain line, an air gap is necessary.

## Materials

Body:	Bronze
Check Seats:	909 Celcon®
Relief Valve Seats:	Stainless steel 909HW
Test Cocks:	Bronze

Celcon® is a registered trademark of Celanese, Limited

## Connections

¾" – 1" (19 – 25mm) 909-NPT Female threaded body connection

1¼" – 2" (32 – 50mm) 909-M1-NPT Male threaded body connection

## Standards

AWWA C-511-92

FCCCHR of USC Manual Section 10

IAPMO (UPC), SBCCI (Standard Plumbing code)

## Approvals

Listed by IAPMO

Listed by SBCCI



\*Approved by the Foundation for Cross-Connection Control and Hydraulic Research at the University of Southern California.

Horizontal and vertical "flow-up" approval on ¾" (20mm) and 1" (25mm) sizes (models 909QT, 909PCQT, and U909QT).

## Pressure – Temperature

Temperature Range: 33°F – 140°F (0.5°C – 60°C) continuous, 180°F (82°C) intermittent

Maximum Working Pressure: 175psi (12.1 bar)

### Series 909HW:

Temperature Range: 33°F – 210°F (0.5°C – 99°C)

Maximum Working Pressure: 175psi (12.1 bar)

## How it Operates

The unique relief valve construction incorporates two channels: one for air, one for water. When the relief valve opens, as in the accompanying air-in/water-out diagram, the right-hand channel admits air to the top of the reduced pressure zone, relieving the zone vacuum. The channel on the left then drains the zone to atmosphere. Therefore, if both check valves foul, and simultaneous negative supply and positive backpressure develop, the relief valve uses the air-in/water-out principle to stop potential backflow.

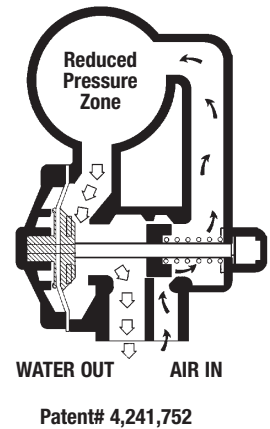

## Dimensions – Weights

When installing a drain line use 909AG series Air Gaps on Series 909 backflow preventers. \*909EL series elbows are for air gaps on backflow preventers in vertical installations.

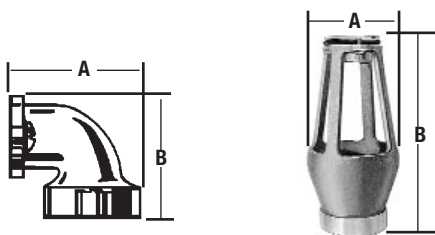

### Series 909AG Air Gaps

Iron Body No.	909 DRAIN Desc.	SIZES		OUTLET		DIMENSIONS				WEIGHTS	
		in.	mm	in.	mm	A		B		lbs.	kg.
909-AG-C	Air Gap	¾, 1	19, 25	1	25	¾	83	4 7/8	124	1 1/2	.7
909-EL-C	Elbow*	¾, 1	19, 25	–	–	2 3/8	60	2 3/8	60	3/8	.2
909-AG-F	Air Gap	1 1/4-2	32-50	2	50	4 3/8	111	6 3/4	171	3 1/4	1.5
909-EL-F	Elbow*	1 1/4-2	32-50	–	–	3 5/8	92	3 5/8	92	2	.9

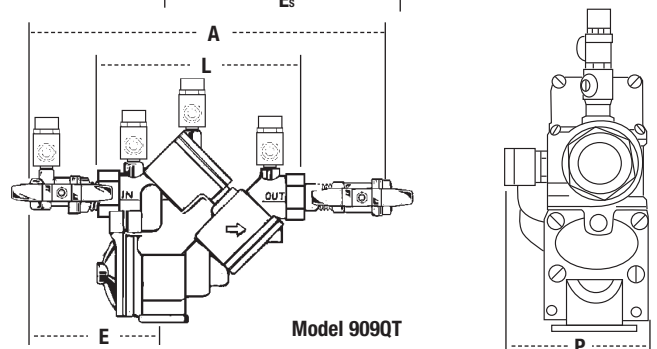
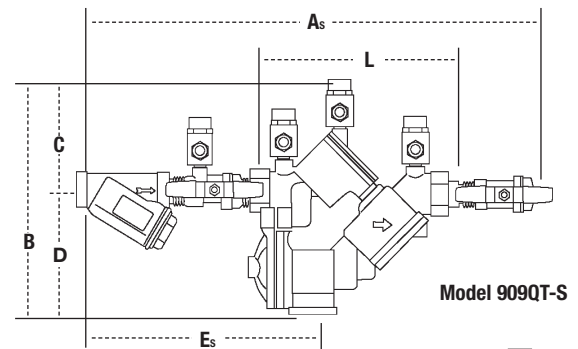

# Capacity

As compiled from documented Foundation for Cross-Connection Control and Hydraulic Research of the University of Southern California lab tests.  
 \*Typical maximum system flow rate (7.5 feet/sec.)

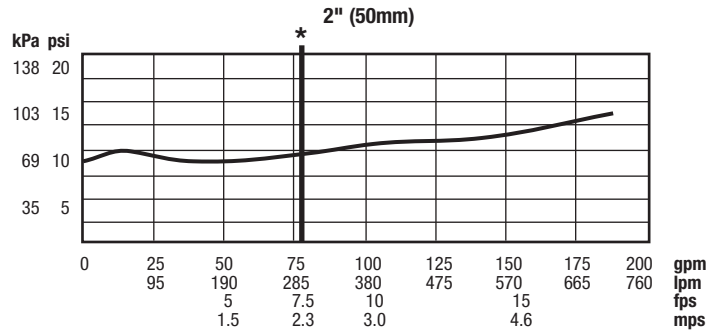
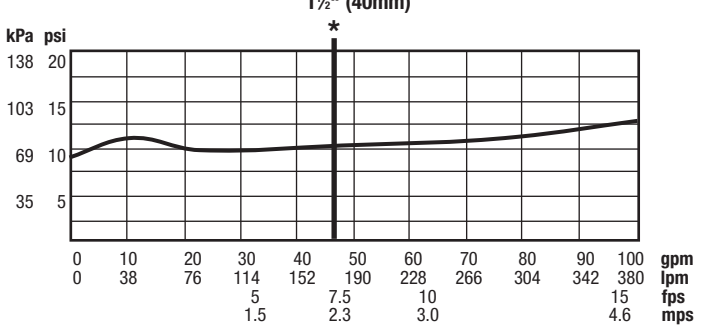
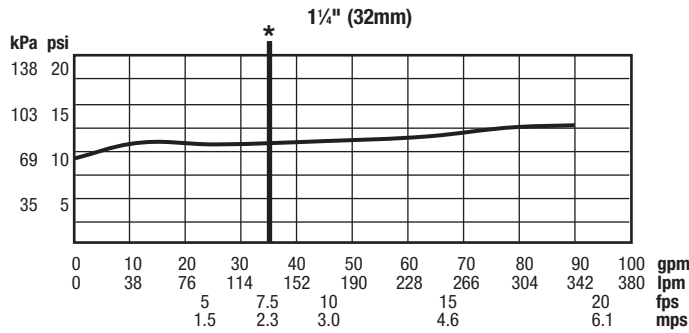
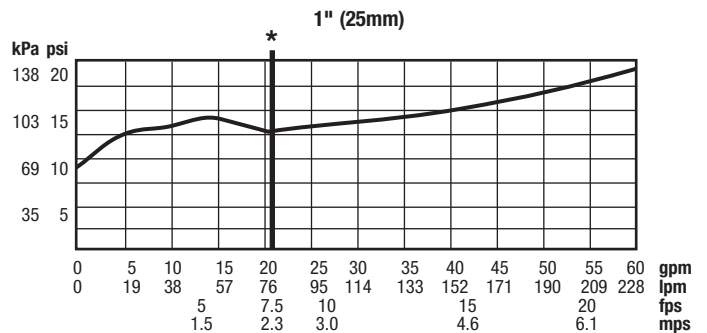
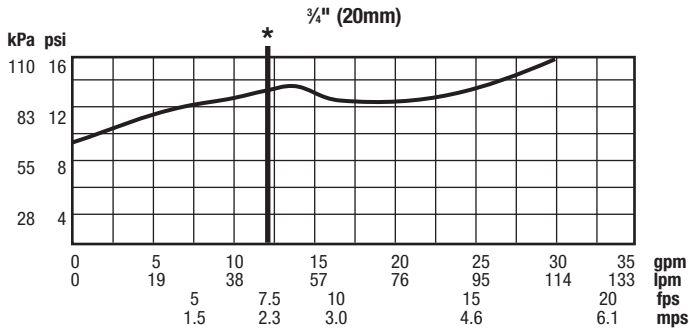

## Suffix HC - Fire Hydrant Fittings dimension "A" = 23 3/4" (603mm)

SIZE (DN)	DIMENSIONS										WEIGHT					
	A	As	B	C	D	E	Es	L	P	QT	QT-S					
	in.	mm	in.	mm	in.	mm	in.	mm	in.	mm	in.	mm	lbs.	kgs.	lbs.	kgs.

### \*909QT, 909QT-S Dimensions

3/4"	14 3/8	365	18 1/16	459	8 3/4	222	4	102	4 3/4	121	6 3/4	171	10 11/16	259	7 7/16	186	3 3/8	98	14	6.4	15.6	7.1
1"	15 1/2	391	19 3/8	498	8 3/4	222	4	102	4 3/4	121	7	178	11	279	7 7/16	186	3 3/8	98	15	6.8	17.5	7.9
1 1/4" M1	18 1/2	470	23 3/16	595	11 1/8	295	5 1/2	140	6 1/2	165	7 1/2	191	12 3/16	310	10 3/8	264	5 1/4	133	40	18.1	42.8	19.4
1 1/2" M1	19	483	24 3/8	619	11 1/8	295	5 1/2	140	6 1/2	165	7 1/2	191	12 3/8	321	10 3/8	264	5 1/4	133	40	18.1	44.0	20.0
2" M1	19 1/2	495	25 15/16	659	11 1/8	295	5 1/2	140	6 1/2	165	7 3/4	197	13 15/16	354	10 3/8	264	5 1/4	133	40	18.1	47.4	21.5

### \*U909QT Dimensions - with integral body unions (Prefix "U")

3/4"	14 3/8	371	19 1/16	484	8 3/4	222	4	102	4 3/4	121	6 3/4	171	10 11/16	259	7 7/16	186	3 3/8	98	14	6.4	15.6	7.1
1"	15 1/2	397	20 15/16	532	8 3/4	222	4	102	4 3/4	121	7	178	11	279	7 7/16	186	3 3/8	98	15	6.8	17.5	7.9

### \*FAE909QT - Dimensions with flanged adapter ends (Prefix "FAE")

1 1/4"	19	483	24 1/2	622	11 1/8	295	5 1/2	140	6 1/2	165	7 1/2	191	12 3/16	310	10 3/8	264	5 1/4	133	40	18.1	42.8	19.4
1 1/2"	19 3/4	502	26 3/8	664	11 1/8	295	5 1/2	140	6 1/2	165	7 1/2	191	12 3/8	321	10 3/8	264	5 1/4	133	40	18.1	44.0	20.0
2"	21	533	28 3/8	721	11 1/8	295	5 1/2	140	6 1/2	165	7 3/4	197	13 15/16	354	10 3/8	264	5 1/4	133	40	18.1	47.4	21.5

Subscript 'S' = strainer model

For additional information, visit our web site at: [www.watts.com](http://www.watts.com)



A Watts Water Technologies Company





**Z-1181** ←  
SOLIDS INTERCEPTOR

SPECIFICATION SHEET

TAG \_\_\_\_\_

Dimensional Data (inches and [ mm ]) are Subject to Manufacturing Tolerances and Change Without Notice

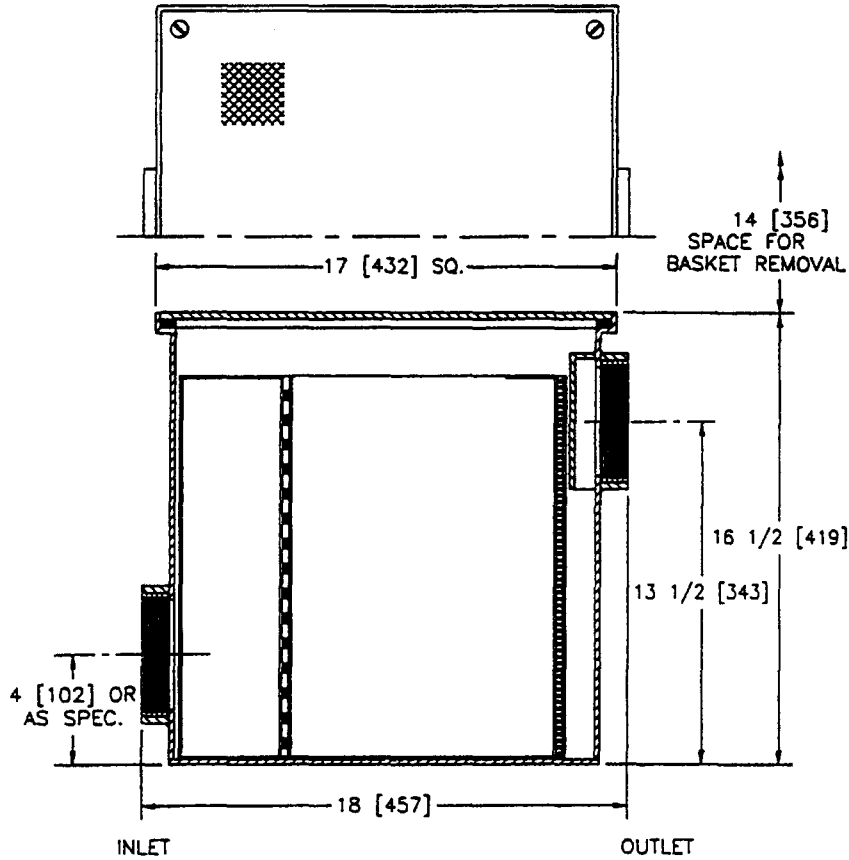

Inlet/Outlet Inches	Flow Rate GPM [L]	Approx. Wt. Lbs. [kg]
1-1/2, 2** [38, 50]	30 [113]	40 [18]

**ENGINEERING SPECIFICATION:** ZURN Z-1181 Large capacity Acid Resistant Coated fabricated steel solids interceptor, in lieu of fixture 'P' trap, for on-floor or flush with floor installation, with removable primary and secondary flow diffusing/intercepting screens, and sediment bucket, with gasketed non-skid cover. Regularly furnished with 2 [50] low inlet and high outlet.\*\*

**OPTIONS** (Check/specify appropriate options)

**PREFIXES**

- \_\_\_ Z- Acid Resistant Coated Fabricated Steel\*
- \_\_\_ ZS- All Fabricated Type 304 Stainless Steel

**SUFFIXES**

- \_\_\_ -SS Custom Stainless Mesh Screen for Bucket (Specify opening size)
- \_\_\_ -YR Replacement Basket Assembly

REV.	DATE: 03/21/95	C.N. NO. 71196
DWG. NO. 58913		PRODUCT NO. Z-1181

\*REGULARLY FURNISHED UNLESS OTHERWISE SPECIFIED

ZURN INDUSTRIES, INC. • HYDROMECHANICS DIV., • 1801 Pittsburgh Ave. • Erie, PA 16514 • Phone: 814/455-0921 Fax: 814/454-7929  
In Canada: ZURN INDUSTRIES LIMITED • 6540 Gottardo Court • Mississauga, Ontario L5T 2A2 • Phone: 905/795-8844 Fax: 905/795-8850

**Features**

- Brass construction
- Available with standard or lever handle
- Intended for use with Rite-Temp® or HiFlow Rite-Temp® valves

**BATH AND SHOWER FAUCET TRIM**

**K-T6908**

ALSO K-T6910, K-T6913

ADA

**Codes/Standards Applicable**

Specified model meets or exceeds the following:

- ASME A112.18.1/CSA B125.1
- IAPMO/UPC
- ADA
- CSA International

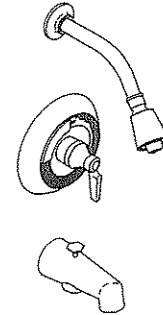



**Colors/Finishes**

- CP: Polished Chrome

**Accessories**

- CP: Polished Chrome
- Other: Refer to Price Book for additional colors/finishes
- NA: None applicable

**Specified Model**

Model	Description		ADA 
K-T6908-2A	Bath and shower trim, standard handle	<input type="checkbox"/> CP	
K-T6908-4A	Bath and shower trim, lever handle		<input type="checkbox"/> CP
K-T6910-2A	Shower only trim, standard handle	<input type="checkbox"/> CP	
K-T6910-4A	Shower only trim, lever handle		<input checked="" type="checkbox"/> CP
K-T6913-2	Valve only trim, standard handle	<input type="checkbox"/> CP	
K-T6913-4	Valve only trim, lever handle		<input type="checkbox"/> CP



**Product Specification**

Rite-Temp® pressure-balancing single-control bath and shower faucet trim shall be of brass construction. Bath and shower trim shall include showerhead with arm and flange, 4-7/8" (12.4 cm) diverter spout with NPT connection, and faceplate with handle. Shower only trim shall include showerhead with arm and flange, and faceplate with handle. Valve only trim shall include faceplate with handle. Faucet trim shall be K-T\_\_\_\_\_ and Rite-Temp® valve shall be K-304-\_\_\_\_-NA OR K-306-KS-NA HiFlow Rite-Temp® valve.

# TRITON®

Required Accessories			
K-304-K	Rite-Temp® valve without stops <b>OR</b>	<input type="checkbox"/> NA	
K-304-KS	Rite-Temp® valve with stops <b>OR</b>	<input type="checkbox"/> NA	
K-306-KS	HiFlow Rite-Temp® valve with integral stops	<input type="checkbox"/> NA	
Recommended Accessories			
88526	HiFlow Rite-Temp® thin wall installation kit	<input type="checkbox"/> CP	<input type="checkbox"/> Other _____
Optional Accessories			
58223	Deep roughing-in kit for Rite-Temp® valve (lever handles)	<input type="checkbox"/> CP	<input type="checkbox"/> Other _____
58229	Deep roughing-in kit for Rite-Temp® valve (standard handles)	<input type="checkbox"/> CP	

## Installation Notes



**WARNING: Risk of damage to the K-306-KS valve assembly.** When using the K-306-KS valve in a fiberglass or acrylic installation, use the thin wall installation kit (88526).

Cap shower outlet if deck-mount spout, diverter, or handshower is connected to spout outlet.

Install straight pipe or tube drop of 7" (17.8 cm) to 18" (45.7 cm) with single elbow between valve and wall-mount spout.

Install this product according to the installation guide.

Avoid cross-flow conditions. Do not install shut-off device on either valve outlet.

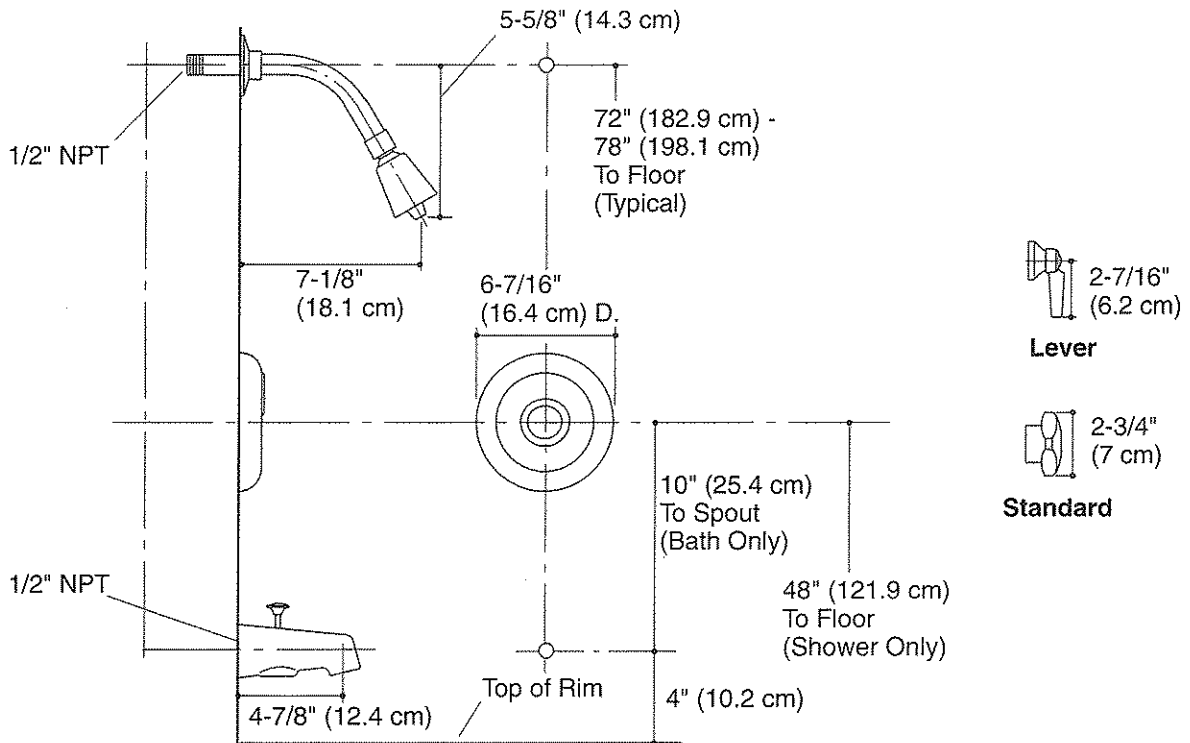

## Product Diagram

**Features**

- Brass valve body
- High-temperature limit setting for added safety
- Mixing valve cycles from "cold" to "hot"
- Rite-Temp pressure-balancing diaphragm design valve
- One-piece diaphragm cartridge design for ease of maintenance
- Available with or without screwdriver stops

**PRESSURE-BALANCING VALVE  
K-304**

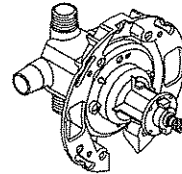

K-304-K

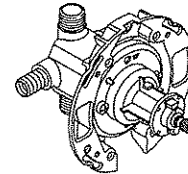

K-304-PX

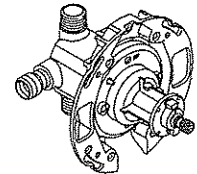

K-304-UX

**Codes/Standards Applicable**

Specified model meets or exceeds the following:

- ASME A112.18.1/CSA B125.1
- ASSE 1016

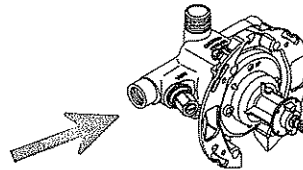

K-304-KS

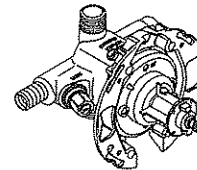

K-304-PS

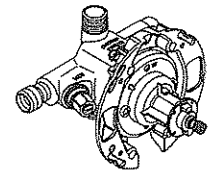

K-304-US

**Colors/Finishes**

- NA: None applicable

**Specified Model**

Model	Description	Colors/Finishes
K-304-K	Pressure-balancing valve without screwdriver stops – universal inlets	<input type="checkbox"/> NA
K-304-KS	Pressure-balancing valve with screwdriver stops – universal inlets	<input checked="" type="checkbox"/> NA
K-304-PX	Pressure-balancing valve without screwdriver stops – PEX inlets (crimp)	<input type="checkbox"/> NA
K-304-PS	Pressure-balancing valve with screwdriver stops – PEX inlets (crimp)	<input type="checkbox"/> NA
K-304-UX	Pressure-balancing valve without screwdriver stops – PEX inlets (cold expansion)	<input type="checkbox"/> NA
K-304-US	Pressure-balancing valve with screwdriver stops – PEX inlets (cold expansion)	<input type="checkbox"/> NA
K-304-CX	Pressure-balancing valve without screwdriver stops – 1/2" CPVC inlets	<input type="checkbox"/> NA
K-304-CS	Pressure-balancing valve with screwdriver stops – 1/2" CPVC inlets	<input type="checkbox"/> NA

The K-304-CX and K-304-CS are K-304-K and K-304-KS with CPVC adapters installed on the inlets.

**Optional Accessories**

58221	Deep roughing-in kit for Rite-Temp® valve for Antique™ valve six-prong and artist edition handles	<input type="checkbox"/> NA
58222	Deep roughing-in kit for Rite-Temp® valve for Antique™ lever handles	<input type="checkbox"/> NA
58223	Deep roughing-in kit for Rite-Temp® valve for IV Georges Brass®, Triton®, lever handles	<input type="checkbox"/> NA
58224	Deep roughing-in kit for Rite-Temp® valve for IV Georges Brass®, cross handles	<input type="checkbox"/> NA
58226	Deep roughing-in kit for Rite-Temp® valve for Taboret®, lever and T-handle	<input type="checkbox"/> NA

Optional accessories continued on page 2

**Product Specification**

Rite-Temp pressure-balancing valve shall have a brass valve body. Product shall include a Rite-Temp pressure-balancing diaphragm design valve with a one-piece diaphragm cartridge design for ease of maintenance. Product shall have mixing valve cycles from "cold" to "hot" and a high-temperature limit stop for added safety. Product shall be available without or with screwdriver stops. Valve shall be Kohler Model K-304-\_\_\_\_-NA.

# RITE-TEMP®

Optional Accessories		
58229	Deep roughing-in kit for Rite-Temp® valve for Triton® standard handles	<input type="checkbox"/> NA
73418	Deep roughing-in kit for Rite-Temp® valve for Pinstripe™, Finial®, Revival®, Memoirs®, Stately and Memoirs® Classic standard handles	<input type="checkbox"/> NA
79639	Deep roughing-in kit for Rite-Temp® valve for Cabriole® lever handles	<input type="checkbox"/> NA
1007937	Deep roughing-in kit for Rite-Temp valve for Fairfax® faucet trim, Coralais® single-control faucet trim lever and acrylic handle, and K-T9492 MasterShower® trim lever and cylinder handle	<input type="checkbox"/> NA
1016154	Deep roughing-in kit for Rite-Temp® valve for Stillness®, Purist® lever and cross handles	<input type="checkbox"/> NA
1025388	Deep roughing-in kit for Rite-Temp® valve for Forte® lever handles	<input type="checkbox"/> NA
1030932	Deep roughing-in kit for Rite-Temp® valve for Devonshire® lever handles	<input type="checkbox"/> NA

## Installation Notes

Install this product according to the installation guide.

Avoid cross-flow conditions. Do not install a shut-off device on either valve outlet.

Cap the shower outlet if a deck-mount spout, diverter, or handshower is connected to a spout outlet.

Install straight pipe or tube drop of 7" (17.8 cm) to 18" (45.7 cm) with single elbow between valve and wall-mount spout. Refer to the installation instructions for proper configuration of the connection between the valve and bath spout.

1/2"-14 NPT or 5/8" ID  
for 1/2" Nominal  
Copper Tubing

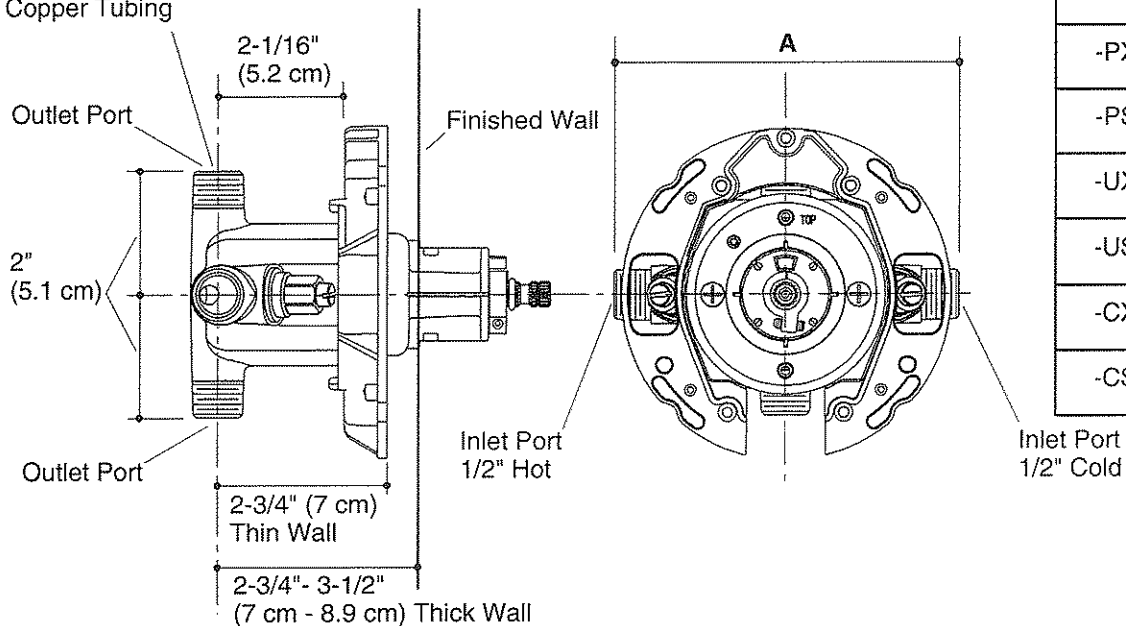

Model	A
-K	4" (10.2 cm)
-KS	5-3/4" (14.6 cm)
-PX	3-3/16" (8.1 cm)
-PS	6-1/8" (15.6 cm)
-UX	4" (10.2 cm)
-US	6-1/8" (15.6 cm)
-CX	6-5/8" (16.8 cm)
-CS	8-1/2" (21.6 cm)

## Product Diagram

RITE-TEMP® PRESSURE-BALANCING VALVE

Page 2 of 2  
1110626-4-A

THE BOLD LOOK  
OF KOHLER.



**MODEL NUMBER:**

☐ **1662.551 Rain Shower System Kit**

Includes:

- Rain Handshower 1660.550
- Hose 8888.035
- Wall Supply 8888.037
- Standard Slide Bar 1660.225

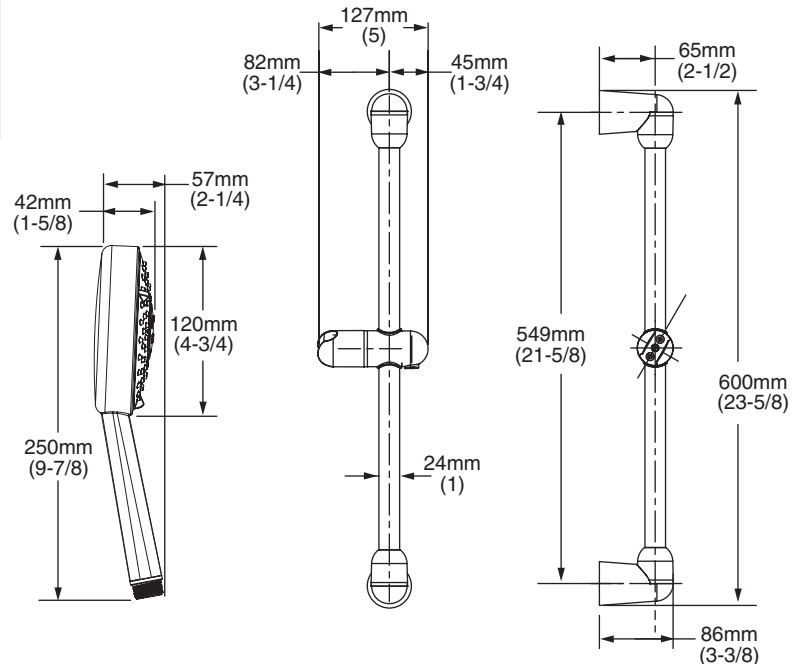
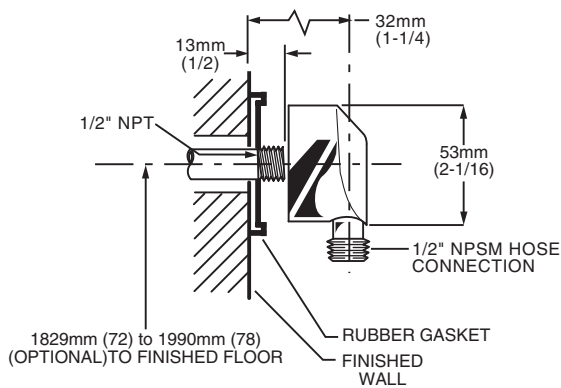

**GENERAL DESCRIPTION:**

Complete personal shower system includes: a wall supply with 1/2" NPT female inlet, 1/2" NPSM male outlet; a 59" (1500mm) shower hose; a "Soft" personal shower; and a 25" Standard Slide Bar. Personal shower adjusts from a conventional spray to a gentle aerated flow. Spray pattern can be changed with the flick of the thumb. 2.5 gpm/9.5L/min. flow restrictor. Adjustable shower holder can be set at any height or position along the bar and angle up to 45°.

**PRODUCT FEATURES:**

**PERSONAL SHOWER**

**Lightweight, Ergonomic Design:** For a sure grip even with wet, soapy hands.

**Variety of Spray Patterns:** Allows the user to select the type of spray best suited to their needs.

**SLIDE BAR**

**Simple Height Adjustment:** Allows positioning of the personal shower anywhere along the bar.

**SELECTION OF FINISHES**

**Available Finishes:** Wide range of durable finishes.

**SUGGESTED SPECIFICATION:**

Shower system shall feature a wall supply with 1/2" NPT female inlets, 1/2" NPSM male outlet, 59" hose, personal shower and a 25" Standard Slide Bar. Personal shower shall be ergonomically designed for a positive grip even when wet. Fitting shall be American Standard Model # 1662.551.\_\_\_\_\_.

**CODES AND STANDARDS**

Install as required to comply with local code requirements.

**ASME A112.18.1**

Product Number	Description	Finish Options			
		Polished Chrome	PVD Blackened Bronze	PVD Stainless Steel	PVD Satin Nickel
		002	068	075	295
1662.551	Rain Shower System Kit. Contains Rain handshower, hose, wall supply and deluxe slide bar.				



# Z880 2 1/2 [64] WIDE TRENCH DRAIN SYSTEM

SPECIFICATION SHEET

TAG \_\_\_\_\_

Dimensional Data (inches and [ mm ]) are Subject to Manufacturing Tolerances and Change Without Notice

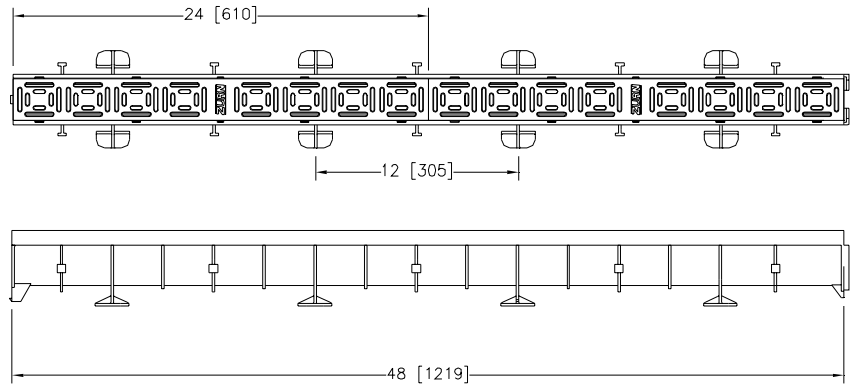
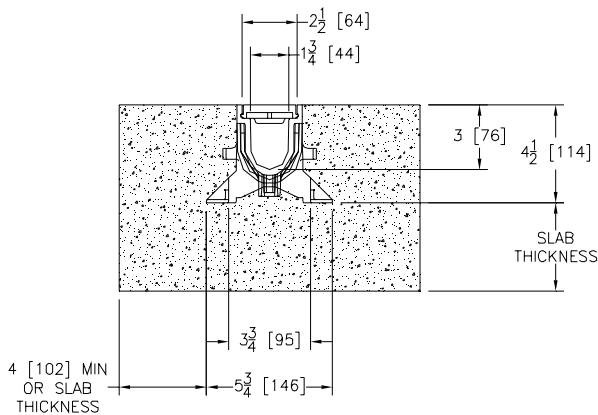

## ENGINEERING SPECIFICATION

**Zurn Z880 2 1/2 [64] Wide Trench Drain System** shall be 48 [1220] long and 2 1/2 [63.5] wide. Drain shall be 3 [76] deep. Drain shall be made of (HDPE) High Density Polyethylene, and is UV-10 stabilized. Drain shall have bedding feet and/or bedding feet shall be used for positioning and anchoring purposes. Drain shall have tongue and groove snap fit connection. Drain shall be Flo-Thru Z880. 24 [610] long high-density polyethylene decorative grate (-POG) provided as standard.

## PREFIX OPTIONS

**Z\***- 48 [1219] linear high density polyethylene modular drain channel with high-density polyethylene decorative grate.

## OPTIONS

- \_\_\_\_\_ **-E1** End Cap
- \_\_\_\_\_ **-E1.5** 1-1/2 [38] No Hub End Outlet
- \_\_\_\_\_ **-U1.5** 1-1/2 [38] No Hub Bottom Outlet
- \_\_\_\_\_ **-C45** 45 Degree Channel
- \_\_\_\_\_ **-C90** 90 Degree Channel
- \_\_\_\_\_ **-G45** 45 Degree Plastic Pool Grate
- \_\_\_\_\_ **-G90** 90 Degree Plastic Pool Grate
- \_\_\_\_\_ **-BZ** Bronze Decorative Grate
- \_\_\_\_\_ **-POG** Heel-Proof Polyethylene Grate
- \_\_\_\_\_ **-SOG** Stainless Steel Decorative Grate

\*Regularly Furnished Unless Otherwise Specified

REV. C	DATE: 07/19/06	C.N. NO. 109009
DWG.NO. 64442	PRODUCT NO. Z880	

ZURN INDUSTRIES, INC., FLO-THRU DIV., 2640 South Work Street, Falconer, NY 14733

Phone: 716/665-1132, Fax: 716/665-1135, World Wide Web: www.zurn.com

In Canada: ZURN INDUSTRIES LIMITED, 3544 Nashua Drive, Mississauga, Ontario L4V1L2, Phone: 905/405-8272 Fax: 905/405-1292

In UK: Zurn Industries Ltd, Riverside Rd, Pottington Business Park, Barnstaple, Devon EX31 1QN, Phone 01271-340350 Fax 01271-344660

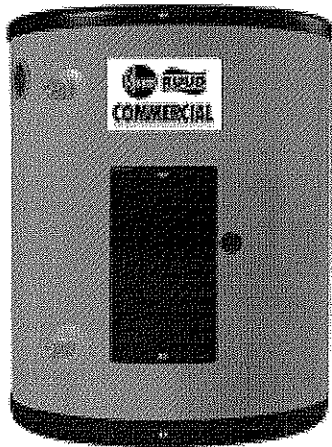

120, 208, 240,  
277 and 480  
voltages



## Available in Sizes Ranging From 2-1/2 – 30 Gallon Tank-Type Models

### ▶ 1440 Watts thru 6000 Watts

Rheem-Ruud point-of-use electric commercial water heaters are designed to provide hot water at the consumption point, eliminating costly temperature loss in long piping runs. Well suited for a wide variety of applications, point-of-use heaters are small enough for installation in limited spaces under counters, mop sinks, cabinets, or any remote area where modest quantities of hot water are required. They are ideally suited for applications in retail stores, public restrooms, office washrooms, kitchen and mop or bar sinks.

### Construction Features:

- **Long life tank design** – proprietary steel formulation with a unique coat of high temperature porcelain enamel to maximize corrosion resistance resulting in a superior tank design. A patented R-Tech anode rod provides advanced technology; equalizing aggressive water action while prolonging the effective life of the anode rod and in turn the life of the tank.
- **Long life heating elements** – Our patented resistor elements are designed with a specially treated, double layer of magnesium oxide and copper to resist corrosion.
- **Efficient design** – Rigid polyurethane foam insulation provides superior insulating qualities resulting in reduced operating costs.
- **Optional wall mounting kit** – The wall mounting kit provides an easy way to mount the unit off the floor, out of the way for more useable floor space in a small area. Each kit is designed to be used on walls with 16" stud centers. All necessary parts are included in this easy to install kit. (Note: The 2-1/2 gallon model comes standard with a wall mounting kit.)
- **Automatic temperature control** – A surface mounted thermostat automatically cycles on and off to maintain the water temperature at a desired preset level.
- **Temperature limiting control** – Automatically and safely cuts off the power in the unlikely event that the water temperature exceeds 190°F.
- **Temperature and pressure relief valve** – AGA/ASME rated and factory installed.

### Certifications and Ratings:

- **Efficiency** – these models meet or exceed thermal efficiency and standby loss requirements of current ASHRAE standards. (Part of the Federally mandated Energy Policy Act (EPact)). Also exceeds energy efficiency codes of all states including California Energy Commission (CEC).
- **Safety and construction** – these products are design certified by Underwriters Laboratories (UL) to meet UL standard 174 as electric storage tank water heaters. All models are North Carolina Code compliant. **CERTIFIED FOR A 150 PSI MAXIMUM WORKING PRESSURE.**

<b>DIMENSIONAL INFORMATION (All dimensions shown in English and Metric)</b>																
MODEL NUMBER	MIN WATTS	MAX WATTS	TANK CAPACITY		A		B		C		D		E		APPROXIMATE SHIPPING WEIGHT	
			GALLONS	LITERS	inches	mm	inches	mm	inches	mm	inches	mm	inches	mm	LBS.	KGS.
EGSP2	1,440	1,500	2.5	9	14	356	9-3/4	248	—	—	—	—	—	—	18	8
EGSP6	1,500	6,000	6	23	15-1/8	384	15-3/4	400	12-5/8	321	11-5/8	295	4-1/4	108	41	19
EGSP10	1,500	6,000	10	38	22-7/8	581	15-3/4	400	20-3/8	518	19-3/8	492	4-1/4	108	53	24
EGSP15	1,500	6,000	15	57	24-1/4	616	17-3/4	451	21-7/8	556	19-3/8	492	4-5/8	117	65	29
EGSP20	1,500	6,000	19.9	75	25-1/8	638	19-3/4	502	22-5/8	575	19-3/8	492	5-1/8	130	76	34
EGSP30	1,500	6,000	30	114	30	762	21-3/4	533	23	584	23	584	2-3/4	70	115	52
<b>Water Temperature Ratings:</b>			Thermostat Type: Surface Mounted				Minimum Temperature: 110°F (43.3°C)			Maximum Temperature: 170°F (76.7°C)			High Temperature Limit: 190°F (87.8°C)			

NOTE: Basic model numbers are listed. When ordering, specify electrical input and kW to determine specific model number.

**MODELS:**

- EGSP6
- EGSP10
- EGSP15
- EGSP20
- EGSP30

Water Connections  
3/4" NPT

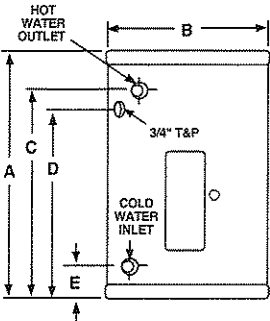

**MODEL:**

- EGSP2

Water Connections  
1/2" NPT

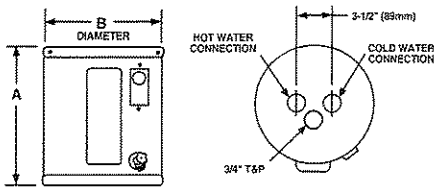

**Recommended Specifications:**

Water heater(s) shall be model \_\_\_\_\_, manufactured by RHEEM-RUUD, having electrical input of \_\_\_\_\_ kW and a recovery rate of \_\_\_\_\_ GPH at a 100°F temperature rise. Water heater(s) shall have a storage capacity of \_\_\_\_\_ gallons. Water heater(s) shall have the UL seal of certification and be factory equipped with an AGA/ASME rated temperature and pressure relief valve. Tank(s) interior shall be coated with a high temperature porcelain enamel and furnished with an R-Tech resistored magnesium anode rod rigidly supported. Water heater(s) shall meet or exceed the energy factor requirements of ASHRAE. Tanks shall have a working pressure rating of 150 psi, and shall be completely assembled. Water heater(s) shall be equipped with a copper, resistored, "screw-in" type element. Tank shall be insulated with rigid polyurethane foam insulation. Water heater(s) shall be equipped with a surface mounted thermostat with an integral, manual reset, high limit control. Water heater(s) shall be covered by a three year limited warranty against tank leaks.

**Limited Warranty:**

This product features a three year limited warranty against tank leaks. Please refer to Commercial Warranty Information brochure for complete warranty information.

**PRODUCT AVAILABILITY**

ELEMENT WATTAGE	SINGLE PHASE OPERATION ONLY				
	120 V	208 V	240 V	277 V	480 V
1,440	Y**	NA	NA	NA	NA
1,500	Y	Y	Y**	N/A	N/A
2,000	Y	Y	Y	Y	Y
2,500	Y	Y	Y	NA	NA
3,000	Y	Y	Y	Y	Y
4,500	NA	Y	Y*	Y*	Y*
6,000	NA	Y	Y	Y	Y

\*Not available in EGSP6 & EGSP10

\*\*EGSP2 available only in these configurations

**ELECTRICAL CHARACTERISTICS**

ELEMENT WATTAGE	SINGLE PHASE OPERATION ONLY - AMPS				
	120 V	208 V	240 V	277 V	480 V
1,440	12.0	NA	NA	NA	NA
1,500	12.5	7.2	6.3	N/A	N/A
2,000	16.7	9.6	8.3	7.2	4.2
2,500	20.8	12.0	10.4	NA	NA
3,000	25.0	14.4	12.5	10.8	6.3
4,500	NA	21.6	18.8	16.2	9.4
6,000	NA	28.8	25.0	21.7	12.5

All models employ 1 heating element resulting in a 2-wire outlet (single phase) electrical configuration.

**RECOVERY CAPACITIES**

Recovery in U.S. Gallons/Hr. (GPH) and Liters/Hr. (LPH) at Various Temperature Rises

ELEMENT WATTAGE	40°F (22°C)		60°F (33°C)		80°F (45°C)		100°F (56°C)		120°F (67°C)	
	GPH	LPH	GPH	LPH	GPH	LPH	GPH	LPH	GPH	LPH
1,440	15	55	10	37	7	28	6	22	5	18
1,500	15	58	10	38	8	29	6	23	5	19
2,000	20	77	14	51	10	38	8	31	7	26
2,500	25	96	17	64	13	48	10	38	8	32
3,000	30	115	20	77	15	58	12	46	10	38
4,500	46	173	30	115	23	86	18	69	15	58
6,000	61	230	41	153	30	115	24	92	20	77



**COMMERCIAL WATER HEATERS**

In keeping with its policy of continuous progress and product improvement, Rheem-Ruud reserves the right to make changes without notice.

Rheem Water Heating • 101 Bell Road, Montgomery, Alabama 36117-4305 • www.rheem.com

Rheem Canada Ltd./Ltée, 128 Barton Street West, Hamilton, Ontario L8N 3P3

# RECOMMENDED PRODUCT SPECIFICATION

CHARLOTTE  
PIPE AND FOUNDRY COMPANY

## Suggested Specification

**System:** PVC Schedule 40 Pressure Pipe and Fitting System

**Scope:** This specification covers PVC Schedule 40 pipe and fittings for pressure applications. This system is intended for pressure applications where the operating temperature will not exceed 140°F.

**Specification:** Pipe and fittings shall be manufactured from virgin rigid PVC (polyvinyl chloride) vinyl compounds with a Cell Class of 12454 as identified in ASTM D 1784.

PVC Schedule 40 pipe shall be Iron Pipe Size (IPS) conforming to ASTM D 1785. PVC Schedule 40 fittings shall conform to ASTM D 2466. Pipe and fittings shall be manufactured as a system and be the product of one manufacturer. All pipe and fittings shall be manufactured in the United States. Pipe and fittings shall conform to National Sanitation Foundation (NSF) Standard 61 or the health effects portion of NSF Standard 14.

Installation shall comply with the latest installation instructions published by Charlotte Pipe and Foundry and shall conform to all local plumbing, building, and fire code requirements. Solvent cement joints shall be made in a two step process with primer manufactured for thermoplastic piping systems and solvent cement conforming to ASTM D 2564. The system shall be protected from chemical agents, fire stopping materials, thread sealant, plasticized vinyl products, or other aggressive chemical agents not compatible with PVC compounds. Systems shall be hydrostatically tested after installation. Testing with compressed air or gas is not recommended.

### Referenced Standards:

→	ASTM D 1784	Rigid Vinyl Compounds
→	ASTM D 1785	PVC Plastic Pipe, Schedule 40
→	ASTM D 2466	PVC Plastic Fittings, Schedule 40
→	ASTM D 2564	Solvent Cements for PVC Pipe and Fittings
	NSF Standard 14	Plastic Piping Components and Related Materials
	NSF Standard 61	Drinking Water System Components - Health Effects

Note: Latest revision of each standard applies.

### Short Specification:

Pipe and fittings shall be manufactured from PVC compound with a cell class of 12454 per ASTM D 1784 and conform with National Sanitation Foundation (NSF) standards 14 and 61. Pipe shall be iron pipe size (IPS) conforming to ASTM D 1785. Fittings shall conform to ASTM D 2466.

All pipe and fittings to be produced by a single manufacturer and to be installed in accordance with manufacturer's recommendations and local code requirements. Solvent cements shall conform to ASTM D 2564, primer shall conform to ASTM F 656. The system to be manufactured by Charlotte Pipe and Foundry Company and is intended for pressure applications where the temperature will not exceed 140°F.

# RECOMMENDED PRODUCT SPECIFICATION

CHARLOTTE  
PIPE AND FOUNDRY COMPANY

GENERAL INFORMATION

## Suggested Specification

**System:** PVC Schedule 40 Solid Wall Pipe and PVC DWV Fitting System

**Scope:** This specification covers PVC Schedule 40 solid wall pipe and PVC DWV fittings used in sanitary drain, waste, and vent (DWV), sewer, and storm drainage applications. This system is intended for use in non-pressure applications where the operating temperature will not exceed 140°F.

**Specification:** Pipe and fittings shall be manufactured from virgin rigid PVC (polyvinyl chloride) vinyl compounds with a Cell Class of 12454 as identified in ASTM D 1784.

PVC Schedule 40 pipe shall be Iron Pipe Size (IPS) conforming to ASTM D 1785 and ASTM D 2665. PVC DWV fittings shall conform to ASTM D 2665. Pipe and fittings shall be manufactured as a system and be the product of one manufacturer. All pipe and fittings shall be manufactured in the United States. All systems shall utilize a separate waste and vent system. Pipe and fittings shall conform to National Sanitation Foundation Standard 14.

Installation shall comply with the latest installation instructions published by Charlotte Pipe and Foundry and shall conform to all local plumbing, building, and fire code requirements. Solvent cement joints shall be made in a two step process with primer manufactured for thermoplastic piping systems and solvent cement conforming to ASTM D 2564. The system shall be protected from chemical agents, fire stopping materials, thread sealant, plasticized vinyl products, or other aggressive chemical agents not compatible with PVC compounds. Systems shall be hydrostatically tested after installation. Testing with compressed air or gas is not recommended.

### Referenced Standards:

→	ASTM D 1784	Rigid Vinyl Compounds
→	ASTM D 1785	PVC Plastic Pipe, Schedule 40
→	ASTM D 2665	PVC Drain, Waste, and Vent Pipe & Fittings
→	ASTM D 2564	Solvent Cements for PVC Pipe and Fittings
	NSF Standard 14	Plastic Piping Components and Related Materials

Note: Latest revision of each standard applies.

### Short Specification:

Pipe and fittings shall be manufactured from PVC compound with a cell class of 12454 per ASTM D 1784 and conform with National Sanitation Foundation (NSF) standard 14. Pipe shall be iron pipe size (IPS) conforming to ASTM D 1785 and ASTM D 2665. Fittings shall conform to ASTM D 2665.

All pipe and fittings to be produced by a single manufacturer and to be installed in accordance with manufacturer's recommendations and local code requirements. Solvent cements shall conform to ASTM D 2564, primer shall conform to ASTM F 656. The system to be manufactured by Charlotte Pipe and Foundry Company and is intended for non-pressure drainage applications where the temperature will not exceed 140°F.

# PHYSICAL PROPERTIES OF ABS AND PVC MATERIALS

Plastics Technical Manual

PROPERTY	UNITS	ABS	ASTM NO.	PVC	ASTM NO.
Specific Gravity	g/cc	1.05	D 792	1.40	D 792
Tensile Strength (73°F) Minimum	Psi	4,500	D 638	7,000	D 638
Modulus of Elasticity in Tension (73°F) Minimum	Psi	240,000	D 638	400,000	D 638
Flexural Strength (73°F)	Psi	10,585	D 790	14,000	D 790
Izod Impact (notched at 73°F) Minimum	ft lb/ in.	6.00	D 256	0.65	D 256
Hardness (Durometer D)		70	D 2240	80 ± 3	D 2240
Hardness (Rockwell R)		100	D 785	110 - 120	D 785
Compressive Strength (73°F)	Psi	7,000	D 695	9,600	D 695
Hydrostatic Design Stress	Psi	N/A		2,000	D 1598
Coefficient of Linear Expansion	in./ in./ °F	5.5 x 10 <sup>-5</sup>	D 696	3.0 x 10 <sup>-5</sup>	D 696
Heat Distortion Temperature at 264 psi Minimum	degrees F	180	D 648	160	D 648
Coefficient of Thermal Conductivity	BTU/ hr/sq ft/ °F/ in.	1.1	C 177	1.2	C 177
Specific Heat	BTU/ °F/lb	0.35	D 2766	0.25	D 2766
Water Absorption (24 hrs at 73°F)	% weight gain	0.40	D 570	.05	D 570
Cell Classification - Pipe		42222	D 3965	12454	D 1784
Cell Classification - Fittings		32222	D 3965	12454	D 1784

Above data is based upon information provided by the raw material manufacturers. It should be used only as a recommendation and not as a guarantee of performance.

## ABS and PVC Standards

TYPE PIPE / FITTING	STANDARD SPECIFICATIONS	
	MATERIAL	DIMENSIONS
<b>ABS DWV</b>		
Schedule 40 DWV Foam Core Pipe	ASTM D 3965	ASTM F 628
Schedule 40 DWV Fittings	ASTM D 3965	ASTM D 2661
<b>PVC DWV</b>		
Schedule 40 DWV Pipe	ASTM D 1784	ASTM D 2665 & ASTM D 1785
Schedule 40 DWV Foam Core Pipe	ASTM D 4396	ASTM F 891
Schedule 40 DWV Fittings	ASTM D 1784	ASTM D 2665
<b>PVC Pressure</b>		
Schedule 40 Plain End Pipe	ASTM D 1784	ASTM D 1785
Schedule 40 Bell End Pipe	ASTM D 1784	ASTM D 1785
Schedule 40 Bell End Well Casing	ASTM D 1784	ASTM D 1785 & ASTM F 480
SDR 21 (PR 200) Bell End Pipe	ASTM D 1784	ASTM D 2241
SDR 26 (PR 160) Bell End Pipe	ASTM D 1784	ASTM D 2241
Schedule 40 Fittings	ASTM D 1784	ASTM D 2466
Schedule 80 Plain End Pipe	ASTM D 1784	ASTM D 1785
Schedule 80 Fittings	ASTM D 1784	ASTM D 2464 & ASTM D 2467

# OUTSIDE DIAMETER AND THICKNESS

CHARLOTTE  
PIPE AND FOUNDRY COMPANY

## PVC Pipe: Schedule 40

NSF

>> PVC Schedule 40 Pipe - Plain End

PVC SCHEDULE 40 (WHITE)		PLAIN END		PVC 1120	ASTM D 1785	
PART NO.	NOM. SIZE	UPC # 611942-	AVG. OD (IN.)	MIN. WALL (IN.)	MAX WORK PRESSURE AT 23° C OR 73° F	WT. PER 100 FT. (LBS.)
PVC 4005	1/2"x10'	06658	.840	.109	600 PSI	15.9
PVC 4005	1/2"x20'	03922	.840	.109	600 PSI	15.9
PVC 4007	3/4"x10'	06661	1.050	.113	480 PSI	21.1
PVC 4007	3/4"x20'	03925	1.050	.113	480 PSI	21.1
PVC 4010	1"x10'	06664	1.315	.133	450 PSI	31.3
PVC 4010	1"x20'	03928	1.315	.133	450 PSI	31.3
PVC 7100*	1 1/4"x10'	03945	1.660	.140	370 PSI	42.4
PVC 7100*	1 1/4"x20'	03946	1.660	.140	370 PSI	42.4
PVC 7112*	1 1/2"x10'	03947	1.900	.145	330 PSI	50.7
PVC 7112*	1 1/2"x20'	03948	1.900	.145	330 PSI	50.7
PVC 7200*	2"x10'	03949	2.375	.154	280 PSI	68.1
PVC 7200*	2"x20'	03950	2.375	.154	280 PSI	68.1
PVC 4025*	2 1/2"x20'	04205	2.875	.203	300 PSI	108.0
PVC 7300*	3"x10'	03951	3.500	.216	260 PSI	141.2
PVC 7300*	3"x20'	03952	3.500	.216	260 PSI	141.2
PVC 7400*	4"x10'	03953	4.500	.237	220 PSI	201.2
PVC 7400*	4"x20'	03954	4.500	.237	220 PSI	201.2
PVC 7500*	5"x20'	04837	5.563	.258	190 PSI	272.5
PVC 7600*	6"x10'	03955	6.625	.280	180 PSI	353.7
PVC 7600*	6"x20'	03956	6.625	.280	180 PSI	353.7
PVC 7800*	8"x20'	03958	8.625	.322	160 PSI	532.3
PVC 7910*	10"x20'	03959	10.750	.365	140 PSI	754.7
PVC 7912*	12"x20'	03961	12.750	.406	130 PSI	997.9
PVC 7914*	14"x20'	04862	14.000	.437	130 PSI	1180.1
PVC 7916*	16"x20'	04918	16.000	.500	130 PSI	1543.1

\* Dual marked ASTM D 1785 and ASTM D 2665.

NOTE: When ordering, please specify plain end or bell end.

NSF Listed. Meets All Requirements of ASTM D 1784 and ASTM D 1785.

PVC piping products are not recommended for use with compressed air or gases.

All Charlotte Pipe and Foundry Company Products are made in U.S.A.

You can't beat the system.®

# OUTSIDE DIAMETER AND THICKNESS

Plastics Technical Manual

## PVC Schedule 40 Pipe - Bell End\*

PVC SCHEDULE 40 (WHITE)			BELL END		PVC 1120	ASTM D 1785	
PART NO.	NOM. SIZE	UPC # 611942-	AVG. OD (IN.)	MIN. WALL (IN.)	MAX WORK PRESSURE AT 23° C OR 73° F	BELL DEPTH (IN.)	WT. PER 100 FT. (LBS.)
PVC 4005B**	1/2"x10'	04986	.840	.109	600 PSI	2.00	15.9
PVC 4005B**	1/2"x20'	03923	.840	.109	600 PSI	2.00	15.9
PVC 4007B**	3/4"x10'	04987	1.050	.113	480 PSI	2.25	21.1
PVC 4007B**	3/4"x20'	03926	1.050	.113	480 PSI	2.25	21.1
PVC 4010B**	1"x10'	04988	1.315	.133	450 PSI	2.50	31.3
PVC 4010B**	1"x20'	03929	1.315	.133	450 PSI	2.50	31.1
PVC 4012B§	1 1/4"x10'	04989	1.660	.140	370 PSI	2.75	42.4
PVC 4012B§	1 1/4"x20'	03930	1.660	.140	370 PSI	2.75	42.4
PVC 4015B§	1 1/2"x10'	04990	1.900	.145	330 PSI	3.00	50.7
PVC 4015B§	1 1/2"x20'	03931	1.900	.145	330 PSI	3.00	50.7
PVC 4020B†	2"x10'	04991	2.375	.154	280 PSI	4.00	69.2
PVC 4020B†	2"x20'	03932	2.375	.154	280 PSI	4.00	69.2
PVC 4025B‡	2 1/2"x10'	04992	2.875	.203	300 PSI	4.00	110.0
PVC 4025B‡	2 1/2"x20'	04206	2.875	.203	300 PSI	4.00	110.0
PVC 7300B§	3"x10'	04853	3.500	.216	260 PSI	4.00	145.1
PVC 4030B†	3"x20'	03933	3.500	.216	260 PSI	4.00	144.5
PVC 7400B§	4"x10'	04835	4.500	.237	220 PSI	4.00	207.9
PVC 9400B†	4"x20'	03964	4.500	.237	220 PSI	5.00	206.2
PVC 7600B§	6"x10'	04850	6.625	.280	180 PSI	6.50	371.4
PVC 9600B†	6"x20'	03965	6.625	.280	180 PSI	6.50	365.5
PVC 7800B†	8"x10'	09903	8.625	.322	160 PSI	7.00	556.9
PVC 9800B†	8"x20'	03967	8.625	.322	160 PSI	7.00	552.3
PVC 7910B†	10"x10'	00990	10.750	.365	140 PSI	9.00	791.9
PVC 7910B†	10"x20'	03960	10.750	.365	140 PSI	9.00	785.4
PVC 7912B†	12"x20'	03962	12.750	.406	130 PSI	10.00	1046.7
PVC 7914B†	14"x20'	04863	14.000	.437	130 PSI	10.00	1180.1
PVC 7916B†	16"x20'	04929	16.000	.500	130 PSI	10.00	1543.1

\* Bell dimensions meet either ASTM D 2672 or ASTM F 480, depending upon pipe diameter  
 \*\* ASTM D 1785

§ Dual Marked ASTM D 1785 & ASTM D 2665  
 † Triple Marked ASTM D 1785 & ASTM D 2665 & ASTM F 480  
 ‡ Dual Marked ASTM D 1785 & ASTM F 480

PVC piping products are not recommended for use with compressed air or gases.



**Exclusive 10 Year Limited Tank Warranty**

**Lightweight –**  
less than half of conventional products

**No Anode Required**

**System Sentinel™**

**Inconel Heating Elements**

**Industry Leading Insulation Factors –**  
means very low operating costs



## Available in 85 and 105 Gallon Capacities

▶ 12 KW through 24 KW ▶ 208, 240, 270 and 480 voltages

Rheem-Ruud Eclipse electric commercial water heaters are designed to provide hot water where applications require moderate quantities. These units are suited for a wide variety of applications such as retail stores, small offices or any location where a moderate amount of hot water is required.

### Construction Features:

- Composite tank and high density polyethylene dent and scratch resistant jacket.
- Models are in two sizes with capacity of 85 or 105 gallons in 42 total variations.
- Input options are: 12.4, 18 or 24 kW.
- Voltage options are: 208, 240, or 480 VAC in either single phase or 3-phase and 277 VAC in single phase only.
- Element wattages are 3100, 4500 or 6000 in each of the four voltages. The elements are low watt density design (46, 67, 90 watts/sq. in.) with stainless (Inconel) sheath.
- The four Inconel elements are spaced on the front along a vertical line for easy access.
- The power control circuits use 2 surface mounted thermostats and operate in two stages so that a lower control thermostat is for the lower two elements and an upper control is for the upper two elements. The lower element will provide recovery for all needs and the upper two will kick in additionally for larger demands.
- 170° F maximum delivered temperature.
- System Sentinel LED indicators are provided for each element to show power on.
- A switch is provided in the control circuit for installation dry fire protection. See label.
- A temperature and pressure relief valve is installed on top of the unit.
- Water connections at the top of the tank are 1" swivel nuts. A nipple is installed on the outlet (1" x 3" long). The inlet has a vacuum valve connected with a 1 x 1 x 3/4 tee and a 1" close nipple to the swivel.
- 3/4" full flow drain valve.
- Standards approved to UL 1453 and UL/NSF 005.

### Certifications and Ratings:

- **Efficiency** – These models have been tested according to DOE test procedures, and exceed the minimum energy factor requirements of current ASHRAE Standards (Part of the Federally mandated Energy Policy Act (EPact)). Also exceeds energy efficiency codes of all states including California Energy Commission (CEC).
- **Safety and Construction** – These products are design certified by Underwriters Laboratories (UL) to meet UL standard 1453 as electric storage tank water heaters. All models are North Carolina and Massachusetts Code compliant. Certified for a 150 PSI Maximum Working Pressure.

<b>Recovery Capacities</b> Recovery at various temperature rises											
INPUT KW	EQUIVALENT BTU/HR	UNITS	TEMPERATURE RISE								
			40°F (22°C)	50°F (28°C)	60°F (33°C)	70°F (39°C)	80°F (45°C)	90°F (50°C)	100°F (56°C)	110°F (61°C)	120°F (67°C)
12.4	42,309	GPH	126	100	84	72	63	55	50	45	42
		LPH	478	379	318	273	239	209	190	171	159
18	61,420	GPH	186	149	124	106	93	83	74	68	62
		LPH	705	565	470	402	352	315	280	258	235
24	81,893	GPH	248	199	165	142	124	110	99	90	83
		LPH	940	754	625	538	470	417	375	341	315

<b>Electrical Characteristics</b>											
INPUT KW	NUMBER OF ELEMENTS	ELEMENT WATTAGE	NUMBER OF FUSES	NUMBER OF THERMOSTATS	FULL LOAD CURRENT – IN AMPERES						
					208V		240V		277V	480V	
					PHASE 1	PHASE 3	PHASE 1	PHASE 3	PHASE 1	PHASE 1	PHASE 3
12.4	4	3100	8	2	60	39	52	34	45	26	17
18	4	4500	8	2	87	57	75	50	65	38	25
24	4	6000	8	2	115	76	100	66	87	50	35

<b>Dimensional Information</b> All dimensions shown in English and Metric						
MODEL NUMBER	UNITS	A	B	C	D	APPROX. SHIP. WEIGHT
ME85	inches	28-1/4	66-1/4	70-1/4	4-1/2	170 lbs.
	mm	718	1683	1784	114	77 kgs.
ME105	inches	30-1/4	66-1/2	70-3/4	4-1/2	185 lbs.
	mm	768	1689	1797	114	84 kgs.

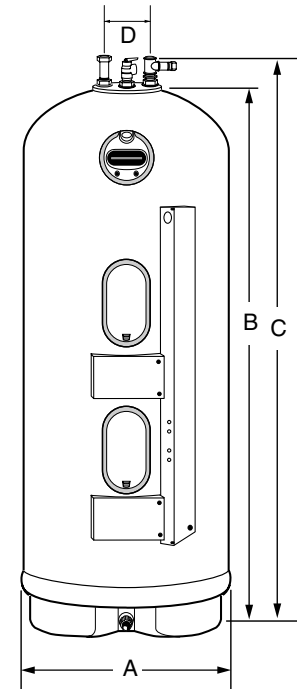

**Recommended Specifications:**

Water heater(s) shall be model \_\_\_\_\_, manufactured by RHEEM-RUUD, having electrical input of \_\_\_\_\_ kW and a recovery rate of \_\_\_\_\_ GPH at a 100°F temperature rise. Water heater(s) shall have a storage capacity of \_\_\_\_\_ gallons. Water heater(s) shall have the UL seal of certification and be factory equipped with an AGA/ASME rated temperature and pressure relief valve. Water heater(s) shall meet or exceed the energy factor requirements of ASHRAE. Tanks shall have a working pressure rating of 150 psi, and shall be completely assembled. Tanks shall be insulated with 2-1/2" of rigid polyurethane foam insulation. Water heater(s) shall be equipped with surface mounted thermostats. Water heater(s) shall be covered by a ten year limited warranty against tank leaks.

**Limited Warranty**

This product features a ten year limited warranty against tank leaks. Please refer to Commercial Warranty Information brochure for complete warranty information.



*In keeping with its policy of continuous progress and product improvement, Rheem-Ruud reserves the right to make changes without notice.*

Rheem Water Heaters • 101 Bell Road, Montgomery, Alabama 36117-4305 • www.rheem.com  
 Rheem Canada Ltd./Ltée, 128 Barton Street West, Hamilton, Ontario L8N 3P3



# Certificate of Product Performance

## Commercial Water Heaters

**Certified Reference Number: 27936**      **Date Generated: 04/20/09**      **Status: Approved**

This certificate serves as verification that the model cited below has been rated in accordance with applicable federal testing methods and verified by AHRI as capable of achieving the energy efficiency and performance ratings as tested within prescribed tolerances. This certificate and these certified ratings ONLY apply to the specific model detailed below and are non-transferable to alternate models or configurations.

### Manufacturer: RHEEM MFG. CO., WATER HEATER DIVISION

**Model Number:** ME105  
**Energy Source:** Electric  
**Heater Type:** Storage  
**Rated Storage Vol:** 105 Gals  
**Input:** 12.4 MBTUH or kWh  
**Thermal Efficcy.:** 100 %  
**Standby Loss:** 273 Btu/hr

Certified ratings for ARI, GAMA, and I-B=R certification programs are valid only for models and configurations listed in the AHRI Directory of Certified Product Performance located at [www.ahridirectory.org](http://www.ahridirectory.org) and [www.gamapower.org](http://www.gamapower.org). The information for the model cited on this certificate can be located in the online directory by using the reference number on the certificate. AHRI

does not endorse the product(s) listed in this certificate and makes no representations, warranties or guarantees and assumes no responsibility for the product(s) listed in the certificate. AHRI expressly disclaims all liability for damages of any kind arising out of the use or performance of the product(s) or the unauthorized alteration of the data listed in this Certificate.



Air-Conditioning,  
Heating, and  
Refrigeration Institute



# “SINGLE POINT”

## CODE COMPLIANT HANDWASHING HEATERS

Instant Comfort...Endless Savings

# ELECTRIC TANKLESS WATER HEATERS

9/06

### MODELS:

	Volts	kW	Amps
SP2412	120V	2.4kW	20A
SP3012	120V	3.0kW	25A
SP3512	120V	3.5kW	29A
SP3208	208V	3.0kW	14.4A
SP4208	208V	4.1kW	19.7A
SP35	240V	3.5kW	14.6A
SP48	240V	4.8kW	20A
SP55	240V	5.5kW	22.9A
SP3277	277V	3.0kW	10.8A
SP4277	277V	4.1kW	14.8A

### SPECIFICATION OPTIONS

- FC = Flex Connector braided-stainless steel water connections available. (EX176, EX177)  
Example: SP3512FC

### APPLICATIONS:

- Shopping Malls
- Office and Tenant Spaces
- Commercial Buildings (restaurants, etc.)
- Modular Buildings/Modular Offices
- Public Hand Washing
- Service Stations
- Schools
- Concessions Stands, Stadiums

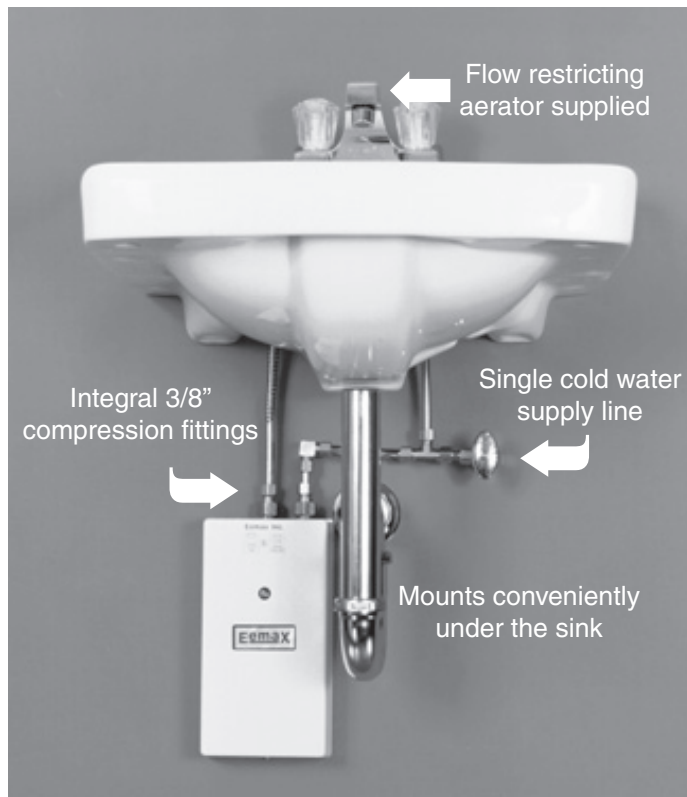

Designed to comply with .5 GPM handwashing code target outlet temperature 105° - 110°.

**ADVANCED TECHNOLOGY • HIGHEST EFFICIENCY**  
**DESIGNED FOR DURABILITY**

**MADE IN USA**

### QUALITY FEATURES

- **On Demand Hot Water** - no delay.
- **Cut Energy Waste** - flow switch activates heater only on demand (no standby heat loss). **99% efficient**
- **Continuous Hot Water** - no storage capacity to run out.
- **Reduces Installation Cost** - no T & P relief valve needed (check local codes).
- **Easy Installation** - only one cold water line need be brought to lavatory - integral 3/8" compression fittings on top (no sweat connections). Mounts on wall at point-of use.
- **Integral Flow Restrictor** - Built in to ensure proper temperature rise. Complies with U.S. Federal regulations.
- **Faucet Aerator** - with excellent spray pattern supplied with unit.
- **Hands Free**, sensor and metering faucet compatible
- **Prevents Legionella Bacteria Growth**
- **Reduces Liming, Calcification and Sedimentation.**
- **Complies with Handicap Requirements**
- **Ni Chrome Element** - a unique, patented flow path ensures optimum heat transfer and extended element life.
- **Compact Size** - dimensions 10.75" x 5.25" x 2.875"; weight 3 lbs.
- **Field Serviceable Element** - replaceable cartridge element (1 year warranty).
- **Warranty** - Full Factory Warranty - Heaters are guaranteed against failure due to leaks of "Heater Body/Element Assembly" for a period of FIVE YEARS.
- **High Temperature Limit Switch** - protects against element burn out, with reset button.

## SUGGESTED SPECIFICATION

Tankless Water Heater shall be an Eemax Model \_\_\_\_\_ with \_\_\_\_\_ vac, \_\_\_\_\_ to heat 0.5 GPM

@ a temperature rise of \_\_\_\_\_ degrees F. Unit shall have \_\_\_\_\_ amperage ABS-UL 94Vo rated cover. Element shall be replaceable cartridge insert. Unit shall have a replaceable filter in the inlet connector and a flow regulator in the outlet connector. Element shall be iron free, nickel chrome material. Heater shall be fitted with 3/8" compression nuts and sleeves to eliminate need for soldering. Heater shall be installed upright with water connections on top only. Hot water storage tanks prohibited. Unit shall be Eemax or approved equal.  
NOTE: Refer to rating chart for product information.

NOTE: Flow Activated 0.5 GPM

OPERATING PRESSURE	
Min.	Max.
25 PSI	150 PSI

### OPTIONAL FLEX CONNECTOR ACCESSORY (FC)

- Stainless steel braid reinforced flexible water connector.
- 3/8" C x 1/2" FIP - 16" faucet supply (EX176)
  - or
  - 3/8" C x 3/8" C - 16" faucet supply (EX177)

## RATINGS OF SINGLE POINT UNITS { Cold water feed only }

MODEL	VOLTS	kW	AMPS	RISE AT 0.5 GPM	RECOMMENDED WIRE SIZE
SP2412	120V	2.4kW	20A	33°	10AWG
SP3012	120V	3.0kW	25A	41°	10AWG
SP3512	120V	3.5kW	29A	48°	10AWG
SP3208	208V	3.0kW	14.4A	41°	14AWG
SP4208	208V	4.1kW	19.7A	56°	12AWG
SP35	240V	3.5kW	14.6A	48°	14AWG
SP48	240V	4.8kW	20A	65°	12AWG
SP55	240V	5.5kW	22.9A	75°	10AWG
SP3277	277V	3.0kW	10.8A	40°	14AWG
SP4277	277V	4.1kW	14.8A	56°	14AWG

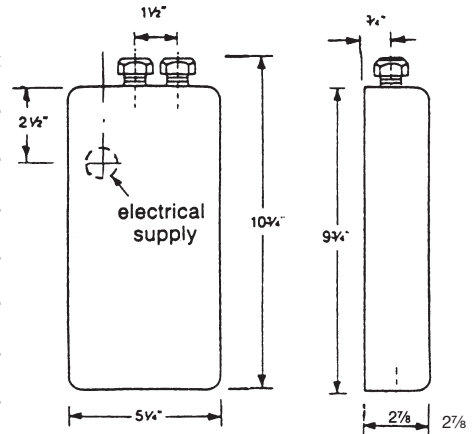

### SPECIFICATIONS:

Dimensions: 10.75" x 5.25" x 2.875"

Weight: 3 lbs.

Materials:

Cover: ABS UL rated 94Vo.

Color: White

Element: Replaceable cartridge insert

Pipe-Fittings: 3/8" compression at top of unit

UL Listed: E86887 (M)

U.S. Patent #'s: 4,762,980 and 4,960,976

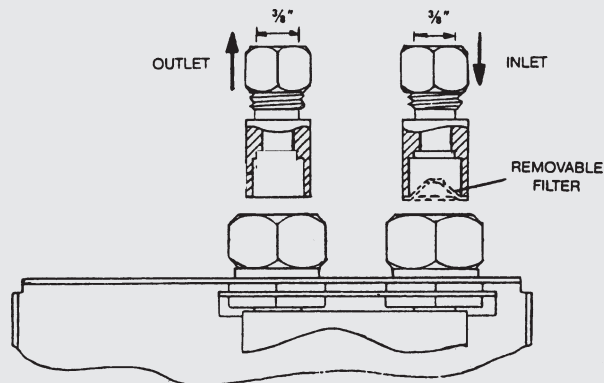

### EEMAX SUBMITTAL

Engineer/Architect: \_\_\_\_\_  
 Job Name/Customer: \_\_\_\_\_  
 Location: \_\_\_\_\_  
 Contractor: \_\_\_\_\_  
 Representative: \_\_\_\_\_  
 HEATER SPECIFICATIONS:

Option	Quantity	kW	Voltage	AMPS	GPM
Single Point Model # SP _____					

### SPECIAL DESIGN SERVICE

INQUIRIES FOR UNITS FOR UNIQUE APPLICATIONS ARE WELCOME. CALL OUR TECHNICAL SERVICE DEPT. 1-800-543-6163

# Eemax® Inc.

353 Christian Street, Oxford, CT 06478

www.eemax.com

Telephone: (203)267-7890

TOLL FREE: 1-800-543-6163

FAX: (203) 267-7975



# Z1400

## "LEVEL-TROL" ADJUSTABLE FLOOR CLEANOUT

SPECIFICATION SHEET

TAG \_\_\_\_\_

Dimensional Data (inches and [ mm ]) are Subject to Manufacturing Tolerances and Change Without Notice

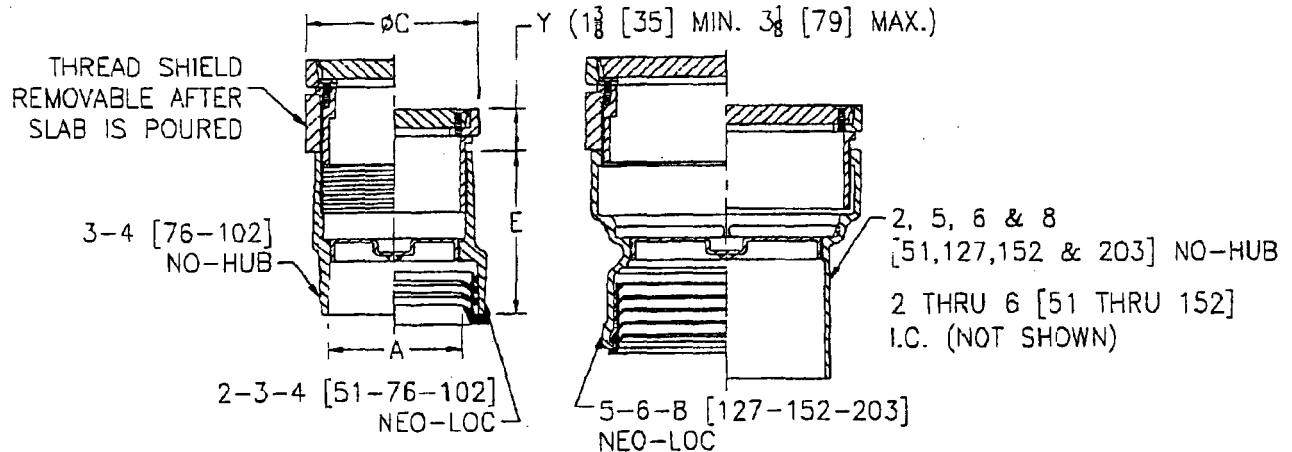

**ENGINEERING SPECIFICATION: ZURN Z1400**

"Level-Trol" Adjustable floor cleanout, Dura-Coated cast iron body, with gas and watertight ABS tapered thread plug, and round scoriated secured top (Specify finish Z, ZB, ZN, ZS) adjustable to finished floor.

**OPTIONS** (Check/specify appropriate options)

A-Pipe Size	Dimension In Inches		Approx. Wt. Lbs. [kg.]
	C	E	
<b>Inside Caulk</b>			
2 [51]	6 1/8 [156]	6 7/8 [175]	13.8 [6.3]
3 [76]	6 1/8 [156]	6 7/8 [175]	14 [6.4]
4 [102]	7 1/4 [184]	6 7/8 [175]	18.3 [8.3]
5 [127]	8 1/4 [210]	6 7/8 [175]	22.6 [10.3]
6 [152]	9 1/4 [235]	6 7/8 [175]	32.2 [14.6]
<b>No-Hub</b>			
2 [51]	4 1/8 [105]	7 1/2 [191]	7 [3]
3 [76]	4 1/8 [105]	5 3/8 [137]	7.7 [3.5]
4 [102]	5 1/8 [130]	5 3/8 [137]	10.3 [4.7]
5 [127]	7 1/4 [184]	7 1/2 [191]	17.6 [8]
6 [152]	8 1/4 [210]	7 1/2 [191]	22.2 [10.1]
8 [203]	9 1/4 [235]	7 1/2 [191]	29.9 [13.6]
<b>Neo-Loc</b>			
2 [51]	4 1/8 [105]	5 3/8 [137]	7.9 [3.6]
3 [76]	5 1/8 [130]	5 3/8 [137]	10.6 [4.8]
4 [102]	5 1/8 [130]	5 3/8 [137]	11.9 [5.4]
5 [127]	7 1/4 [184]	6 1/2 [165]	18.7 [8.5]
6 [152]	8 1/4 [210]	6 1/2 [165]	21.9 [9.9]
8 [203]	9 1/4 [235]	6 1/2 [165]	23.5 [10.7]

**PREFIXES**

- Z Dura Coated Cast Iron\*
- ZB D.C.C.I. w/ Polished Bronze Top (Deduct 1/2 [13] from 'Y' Dim.)
- ZN D.C.C.I. w/ Polished Nickel Bronze Top (Deduct 1/2 [13] from 'Y' Dim.)
- ZS D.C.C.I. w/ Polished Stainless Steel Top

**SUFFIXES**

- AR Acid Resisting Epoxy Coated Finish
- BP Bronze Plug
- CF Carpet Flange Cover (ZB and ZN only)
- CM Carpet Marker
- DC Duresist Cover
- DX Round ZB or ZN Top with Dex-o-tex Flange (2 thru 4 [51 thru 102] Sizes only)
- G Galvanized Cast Iron
- HD Heavy-Duty Top (Add 1/8 [3] to 'Y' Dim.) (ZB and ZN only)
- SG Solid Gasketed Cover
- SM Special Marking Stamped on Top
- T Square Top
- TX Square Top Recessed for 1/8 [3] Tile (ZB and ZN only)
- VP Vandal-Proof Screws
- X Round Top Recessed for 1/8 [3] Tile (ZB or ZN only)
- Z Round Top Recessed for 1 1/4 [32] Terrazzo (ZB or ZN only)

**PIPE SIZE**

- 2 thru 6 [51 thru 152]
- 2 thru 6-8 [51 thru 152-203]
- 2 thru 6-8 [51 thru 152-203]

(Specify size/type) **OUTLET**

- IC Inside Caulk
- NH No-Hub
- NL Neo-Loc

**'E' BODY HT. DIM.**

- See Chart
- See Chart
- See Chart

REV. K    DATE: 10/19/05    C.N. NO. 93985

DWG. NO. 58757    PRODUCT NO. Z1400

\*REGULARLY FURNISHED UNLESS OTHERWISE SPECIFIED

ZURN INDUSTRIES, INC. • SPECIFICATION DRAINAGE OPERATION • 1801 Pittsburgh Ave. • Erie, PA 16514  
 Phone: 814455-0921 • Fax: 814454-7929 • World Wide Web: www.zurn.com  
 In Canada: ZURN INDUSTRIES LIMITED • 3544 Nashua Drive • Mississauga, Ontario L4V1L2 • Phone: 905405-8272 Fax: 905405-1292

WOODFORD



# Anti-Siphon Freezeless Wall Hydrants Model 65/B65

The Model 65 and B65 are automatic draining, freezeless wall hydrants with anti-siphon vacuum breakers. The Model B65 is enclosed in a flush mounted wall box. Both models are designed to blend in with modern architecture for installation on restaurants, schools, office buildings, churches, apartments, motels, stores, shopping centers and industrial buildings.

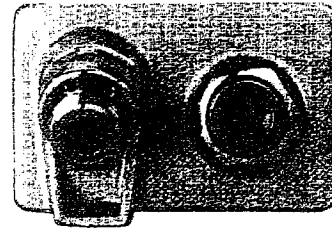

MODEL 65

Exterior Finish:  
Standard - Chrome (CH)  
Optional - Brass (BR) Polished Brass (PB)

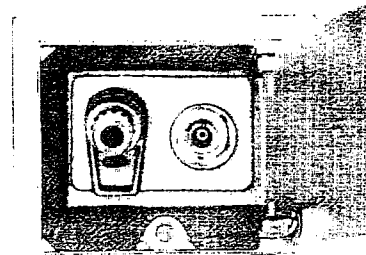

MODEL B65

Exterior Finish: Box & Door  
Standard - Chrome (CH)  
Optional - Brass (BR) Polished Brass (PB)  
Other Options: Anodized or Powder Coated Aluminum Box

**SPECIFICATIONS:**

**MODEL 65/B65** – Approved under ASSE Standard 1019-B and listed by IAPMO®. Meets Government Specification WW-P-541b Type 205.

**VACUUM BREAKER – ANTI-SIPHON** - NIDEL® Model 34HA with 3/4 inch male hose thread, approved under ASSE Standard 1011, Canadian Standards Association and listed by IAPMO®.

**VALVE SEAT** – Permanent type brass valve body with hemispherical seating surface.

**VALVE** – One piece valve plunger accurately controls both flow and drainage with a minimum number of turns and without need for adjustments.

**DRAIN** – Under nozzle away from hands of operator and with a lip to divert water away from building.

**CASING** – Copper tubes.

**NO LEAD SOLDER** - All solder joints.

**STEM** – Hardened stainless steel stem resists damage.

**TEE KEY** – Loose key operates hydrant.

**OPERATING ROD** – 3/8" solid brass operating rod.

**INLETS** – As shown.

**WALL CLAMP** – Furnished on all 65 series except close coupled.

**MAX PRESSURE** – 125 p.s.i.

**MAX TEMPERATURE** - 120° F

**Specify as follows:**

Wall hydrant shall be Woodford Model (65-exposed type) or (B65-concealed box type), automatic draining with anti-siphon vacuum breaker. ASSE Standard 1019-B approved. 3/4" inlet and outlet (specify type of inlet). Hardened stainless steel operating stem and one-piece valve plunger to control both flow and drain functions. Exterior finish to be Chrome Plated (options: Polished Brass or Rough Brass). Loose tee key to be furnished with each hydrant. Wall thickness to be \_\_\_\_\_ inches.

**Inlet Descriptions**

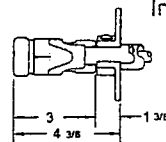

P Inlet  
3/4" FEMALE  
PIPE THREAD

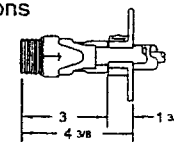

P1 Inlet  
1" MALE  
PIPE THREAD

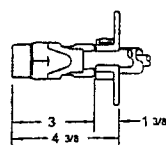

C Inlet  
3/4" COPPER  
WATER TUBE

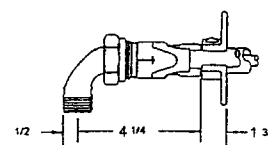

EP Inlet  
UNION ELBOW  
WITH 3/4" MALE  
PIPE THREAD

WOODFORD

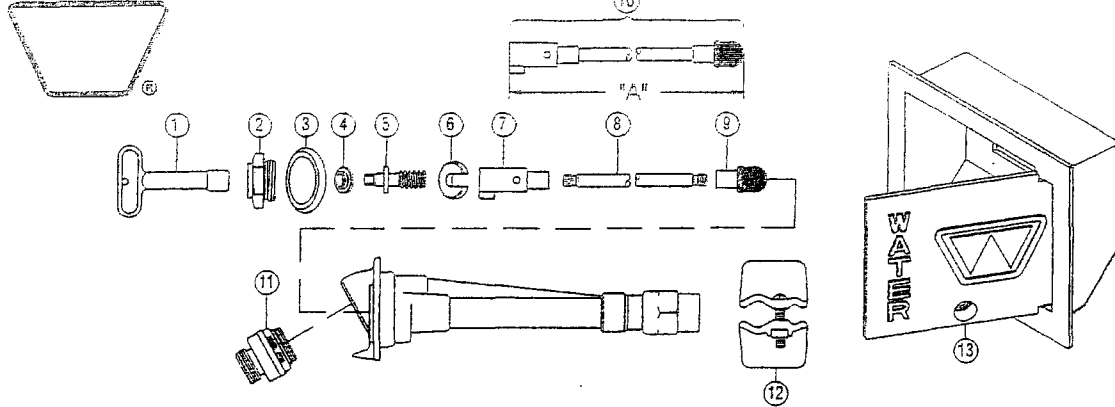

**MODEL 65/B65 PARTS LIST**

- |      |        |  |
|------|--------|--|
| ITEM | PART # | DESCRIPTION  |
| 1    | 50009  | Tee Key  |
|      | 50010  | Long Tee Key (Box Models)  |
| 2    | 50264  | Head Nut - chrome  |
|      | 50265  | Head Nut - brass   |
| 3    | 50583  | I.D. RING  |
| 4    | 50252  | Stem Washer  |
| 5    | 55062  | Stem Screw   |
| 6    | 50251  | "C" washer   |
| 7    | 51014  | Yoke Nut   |
| 8    |        | Operating Rod (Sold With Item 10 Only)   |
| 9    | 50250  | Plunger  |
| 10   | 554XX  | Operating Rod Assembly (Includes Items 7,8,9)<br>(Select required assembled length from table below) |
| 11   | 55058  | Vacuum Breaker - chrome  |
|      | 55057  | Vacuum Breaker - brass   |
| 12   | 55063  | Wall Clamp Assembly  |
| 13   | 55070  | Box/Door Assembly - brass  |
|      | 55071  | Box/Door Assembly - polished brass   |
|      | 55072  | Box/Door Assembly - chrome   |
|      | 55431  | Box/Door Assembly - Anodized Aluminum  |
|      | 55432  | Box/Door Assembly - Powder Coated Aluminum   |

RK-65 Chrome Repair Kit (Includes Items 1-7 & 9)

Operating Rod Assy. "A"			
Wall Thickness		Length	Part No.
65	B65		
CC	CC	3 1/2"	55401
N/A	4	4 1/2"	55402
4	6	6 1/2"	55404
6	8	8 1/2"	55406
8	10	10 1/2"	55408
10	12	12 1/2"	55410
12	14	14 1/2"	55412
14	16	16 1/2"	55414
16	18	18 1/2"	55416
18	20	20 1/2"	55418
20	22	22 1/2"	55420
22	24	24 1/2"	55422
24	N/A	26 1/2"	55424

Manufactured under one or more of the following patents:  
 U.S. Patents:  
 3,414,001  
 4,178,956  
 4,316,481  
 4,532,954  
 D216,790  
 D216,791  
 D277,365  
 D277,366  
 Canada Patents:  
 852,529  
 865,995  
 1,146,438

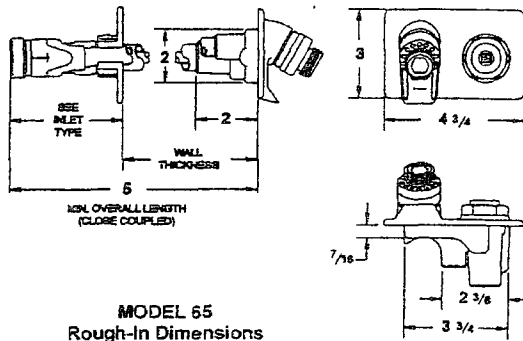

**MODEL 65**  
Rough-In Dimensions

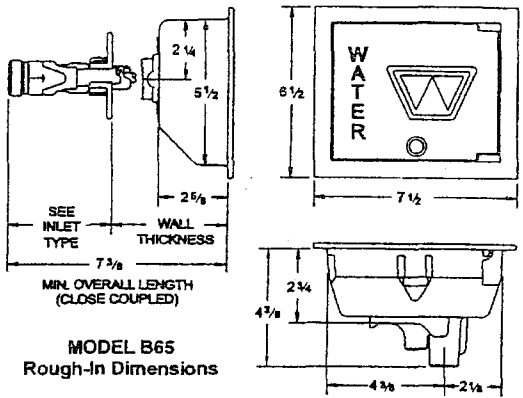

**MODEL B65**  
Rough-In Dimensions

Wall Thickness (In)	CC	4	6	8	10	12	14	16	18	20	22	24
Overall Length*	5	8	10	12	14	16	18	20	22	24	26	28
Shipping Wt. (Lbs)**	3.8	4.4	4.8	5.2	5.5	6	6.4	6.8	7.2	7.6	8	8.4

\*\* Add 7.4 Lbs for brass box models.  
 \*\* Add 2.5 Lbs for Aluminum box models.  
 \*Add 3/8" for all box hydrants except CC units add 2 3/8".

NOTE: Close Coupled Models are not recommended for use in freezing climates and cannot use wall clamp

**WOODFORD MANUFACTURING COMPANY**

2121 Waynoka Road, Colorado Springs, Colorado 80915 • Phone: (719) 574-1101 • Fax: (719) 574-7621  
 To view our complete product line visit: [www.woodfordmfg.com](http://www.woodfordmfg.com)

FOR NON-FREEZING AREAS ONLY

WOODFORD



For maximum protection, vacuum breaker replacement every three to five years is strongly recommended.

## Anti-Contamination Wall and Lawn Faucets

WALL FAUCET MODEL 24

LAWN FAUCET MODEL Y24

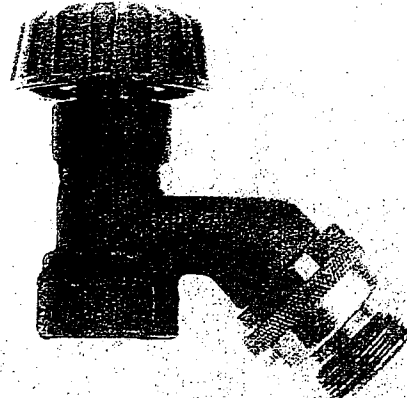
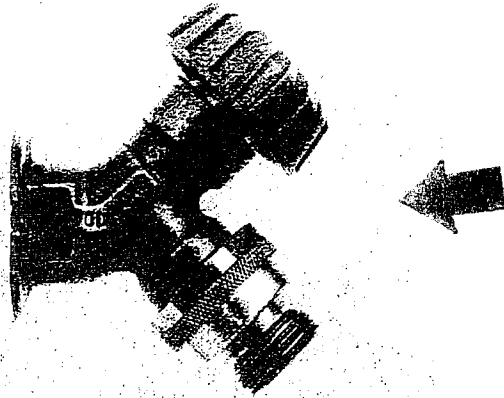

**24P - 1/2**

INLET - 1/2" FPT

INLET - 3/4" FPT

**24P - 3/4**

**24CP**

INLET - 1/2" COPPER TUBE INSIDE

1/2" MPT OUTSIDE

**24C**

INLET - 1/2" COPPER TUBE INSIDE

3/4" COPPER COUPLING OUTSIDE

**Y24**

INLET - 3/4" NPT FEMALE THREAD

Model 24 is an anti-siphon vacuum breaker protected wall faucet for use in mild climate areas on homes, service stations, churches, motels, drive-in restaurants, etc.

Model Y24 is an anti-siphon vacuum breaker protected lawn faucet for use in garden, lawn and other water systems in mild climate areas.

**SPECIFICATIONS:** 24P-1/2, 24P-3/4, 24CP, 24C and Y24

**ANTI-SIPHON VACUUM BREAKER** — NIDEL® Model 34HF with 3/4 inch male hose thread, approved under ASSE Standard 1011, Canadian Standards Association, listed by IAPMO® and accepted by U.S. Department of Health.

**EXTERIOR FINISH** — Brass. Optional polished chrome, polished brass or chrome plated casting with chrome plated vacuum breaker.

**OPERATING HANDLE** — Wheel handle. Polycarbonate. Optional loose tee key. Polished chrome standard loose tee key. Optional wheel handle.

**TAMPER PROOF LOCK SHIELD**

**BRASS CONSTRUCTION** — Adjustable packing nut with deep stem guard. Teflon impregnated packing and standard "O" size washer.

**SHIPPING WEIGHT** — 10 lbs. (approximate weight per master carton of ten units.)

*When ordering specify model number, inlet and finish.*



Z-415  
 BODY ASSEMBLY WITH  
 "TYPE B" STRAINER

SPECIFICATION SHEET

TAG \_\_\_\_\_

Dimensional Data (Inches and [ mm ]) are Subject to Manufacturing Tolerances and Changes Without Notice

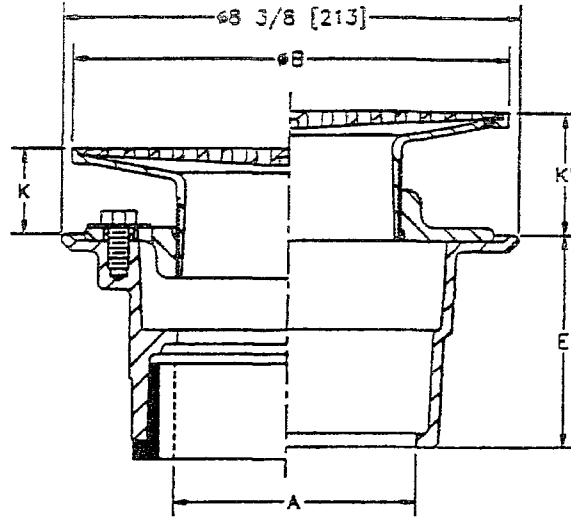
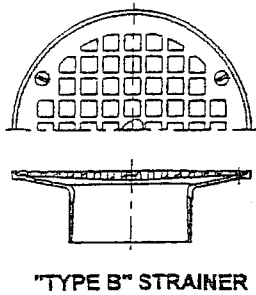

Dimensions in Inches						Approx. Wt. Lbs. [kg]	Strainer Open Area Sq. In. [cm <sup>2</sup> ]
A - Pipe Size	B Strainer Dia.	K		K'			
		Min.	Max.	Min.	Max.		
2-3 [50-75]	5 [127]	1/2 [13]	1 5/8 [41]	1 3/8 [35]	2 3/8 [60]	11 [5]	8 [52]
2-3-4 [50-75-100]	6 [152]	3/4 [19]	1 3/4 [44]	1 5/8 [41]	2 3/4 [70]	13 [6]	9 [58]
2-3-4 [50-75-100]	7 [178]	1 [25]	2 1/4 [57]	2 [51]	3 1/8 [79]	14 [6]	12 [77]
3-4 [75-100]	8 [203]	1 1/8 [29]	2 1/4 [57]	2 [51]	3 1/8 [79]	16 [7]	18 [116]
6 [150]	8 [203]	1 1/8 [29]	2 1/4 [57]	2 [51]	3 1/8 [79]	18 [8]	18 [116]
6 [150]	10 [254]	1 5/8 [41]	2 5/8 [67]	2 5/8 [67]	3 1/2 [89]	22 [10]	26 [168]

**ENGINEERING SPECIFICATION:** ZURN ZN-415 Floor and shower drain, Dura-Coated cast iron body with bottom outlet, combination invertible membrane clamp and adjustable collar with "TYPE B" polished nickel bronze strainer.

**OPTIONS** (Check/specify appropriate options)

PIPE SIZE	(Specify size/type)	OUTLET	'E' BODY HT. DIM.
2 thru 4 [50 thru 100]	_____	IC Inside Caulk	3 7/8 [98]
2 [50]	_____	IP Threaded	2 3/8 [60]
3 [75]	_____	IP Threaded	2 5/8 [67]
4 [100]	_____	IP Threaded	2 7/8 [73]
6 [150]	_____	IP Threaded	2 3/4 [70]
2 thru 4 [50 thru 100]	_____	NH No-Hub	3 7/8 [98]
2 thru 4 [50 thru 100]	_____	NL Neo-Loc	4 5/8 [117]

**PREFIXES**

- \_\_\_\_\_ ZB- D.C.C.I. Body Assembly w/Polished Bronze Top
- \_\_\_\_\_ ZN- D.C.C.I. Body Assembly w/Polished Nickel Bronze Top\*
- \_\_\_\_\_ ZS- D.C.C.I. Body Assembly w/6 [152] Dia. Stainless Steel Top

**SUFFIXES**

- |  |   |
|--|---|
| _____ -AR Acid Resisting Epoxy Coated Cast Iron                | _____ VP Vandal Proof Secured Top                             |
| _____ -G Galvanized Cast Iron                                  | _____ -Y Sediment Bucket                                      |
| _____ -HD Heavy Duty Grate                                     | _____ -90 90° Threaded Side Outlet Body (2 [50], 3 [75] Only) |
| _____ -P Trap Primer Connection (Specify 1/2 [13] or 3/4 [19]) |   |
| _____ -U 3 [76] High Extension Adapter                         |   |
| _____ -V Backwater Valve                                       |   |

\*REGULARLY FURNISHED UNLESS OTHERWISE SPECIFIED

REV. DATE: 03/17/95 C.N. NO. 71067

DWG. NO. 58789 PRODUCT NO. Z-415-B

ZURN INDUSTRIES, INC. • HYDROMECHANICS DIV., • 1801 Pittsburgh Ave. • Erie, PA 16514 • Phone: 814/455-0921 Fax: 814/454-7929  
 In Canada: ZURN INDUSTRIES LIMITED • 6540 Gottardo Court • Mississauga, Ontario L5T 2A2 • Phone: 905/795-8844 Fax: 905/795-8850



# Z1400

## "LEVEL-TROL" ADJUSTABLE FLOOR CLEANOUT

SPECIFICATION SHEET

TAG \_\_\_\_\_

Dimensional Data (inches and [ mm ]) are Subject to Manufacturing Tolerances and Change Without Notice

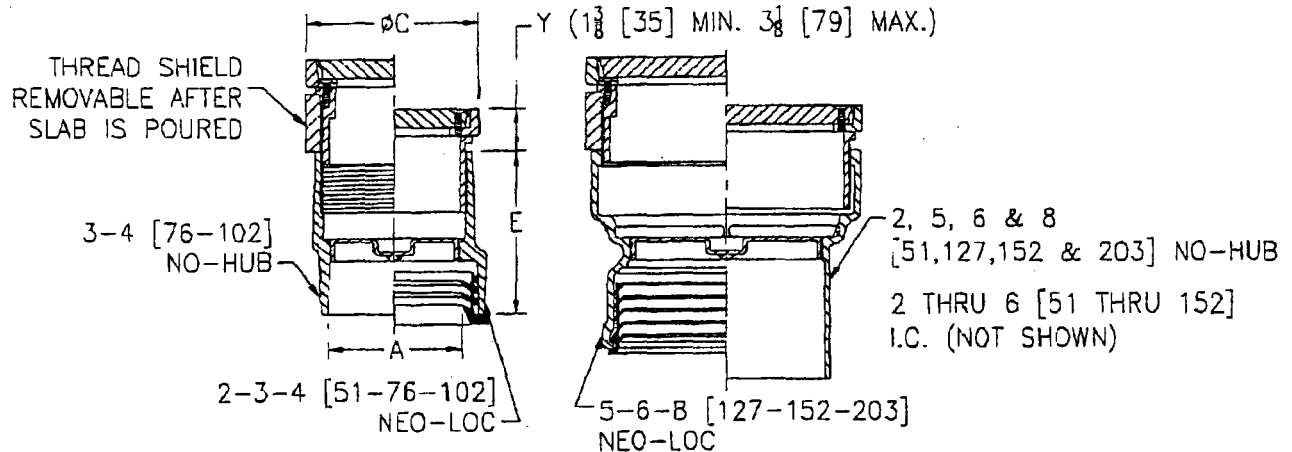

**ENGINEERING SPECIFICATION: ZURN Z1400**

"Level-Trol" Adjustable floor cleanout, Dura-Coated cast iron body, with gas and watertight ABS tapered thread plug, and round scoriated secured top (Specify finish Z, ZB, ZN, ZS) adjustable to finished floor.

**OPTIONS (Check/specify appropriate options)**

A-Pipe Size	Dimension In Inches		Approx. Wt. Lbs. [kg.]
	C	E	
<b>Inside Caulk</b>			
2 [51]	6 1/8 [156]	6 7/8 [175]	13.8 [6.3]
3 [76]	6 1/8 [156]	6 7/8 [175]	14 [6.4]
4 [102]	7 1/4 [184]	6 7/8 [175]	18.3 [8.3]
5 [127]	8 1/4 [210]	6 7/8 [175]	22.6 [10.3]
6 [152]	9 1/4 [235]	6 7/8 [175]	32.2 [14.6]
<b>No-Hub</b>			
2 [51]	4 1/8 [105]	7 1/2 [191]	7 [3]
3 [76]	4 1/8 [105]	5 3/8 [137]	7.7 [3.5]
4 [102]	5 1/8 [130]	5 3/8 [137]	10.3 [4.7]
5 [127]	7 1/4 [184]	7 1/2 [191]	17.6 [8]
6 [152]	8 1/4 [210]	7 1/2 [191]	22.2 [10.1]
8 [203]	9 1/4 [235]	7 1/2 [191]	29.9 [13.6]
<b>Neo-Loc</b>			
2 [51]	4 1/8 [105]	5 3/8 [137]	7.9 [3.6]
3 [76]	5 1/8 [130]	5 3/8 [137]	10.6 [4.8]
4 [102]	5 1/8 [130]	5 3/8 [137]	11.9 [5.4]
5 [127]	7 1/4 [184]	6 1/2 [165]	18.7 [8.5]
6 [152]	8 1/4 [210]	6 1/2 [165]	21.9 [9.9]
8 [203]	9 1/4 [235]	6 1/2 [165]	23.5 [10.7]

**PREFIXES**

- Z Dura Coated Cast Iron\*
- ZB D.C.C.I. w/ Polished Bronze Top (Deduct 1/2 [13] from 'Y' Dim.)
- ZN D.C.C.I. w/ Polished Nickel Bronze Top (Deduct 1/2 [13] from 'Y' Dim.)
- ZS D.C.C.I. w/ Polished Stainless Steel Top

**SUFFIXES**

- AR Acid Resisting Epoxy Coated Finish
- BP Bronze Plug
- CF Carpet Flange Cover (ZB and ZN only)
- CM Carpet Marker
- DC Duresist Cover
- DX Round ZB or ZN Top with Dex-o-tex Flange (2 thru 4 [51 thru 102] Sizes only)
- G Galvanized Cast Iron
- HD Heavy-Duty Top (Add 1/8 [3] to 'Y' Dim.) (ZB and ZN only)
- SG Solid Gasketed Cover
- SM Special Marking Stamped on Top
- T Square Top
- TX Square Top Recessed for 1/8 [3] Tile (ZB and ZN only)
- VP Vandal-Proof Screws
- X Round Top Recessed for 1/8 [3] Tile (ZB or ZN only)
- Z Round Top Recessed for 1 1/4 [32] Terrazzo (ZB or ZN only)

**PIPE SIZE**

- 2 thru 6 [51 thru 152]
- 2 thru 6-8 [51 thru 152-203]
- 2 thru 6-8 [51 thru 152-203]

**(Specify size/type) OUTLET**

- IC Inside Caulk
- NH No-Hub
- NL Neo-Loc

**'E' BODY HT. DIM.**

- See Chart
- See Chart
- See Chart

REV. K    DATE: 10/19/05    C.N. NO. 93985

DWG. NO. 58757    PRODUCT NO. Z1400

\*REGULARLY FURNISHED UNLESS OTHERWISE SPECIFIED

ZURN INDUSTRIES, INC. • SPECIFICATION DRAINAGE OPERATION • 1801 Pittsburgh Ave. • Erie, PA 16514

Phone: 814455-0921 • Fax: 814454-7929 • World Wide Web: www.zurn.com

In Canada: ZURN INDUSTRIES LIMITED • 3544 Nashua Drive • Mississauga, Ontario L4V1L2 • Phone: 905405-8272 Fax: 905405-1292



# Z1185 LINT INTERCEPTOR

SPECIFICATION SHEET

TAG \_\_\_\_\_

Dimensional Data (inches and [ mm ]) are Subject to Manufacturing Tolerances and Change Without Notice

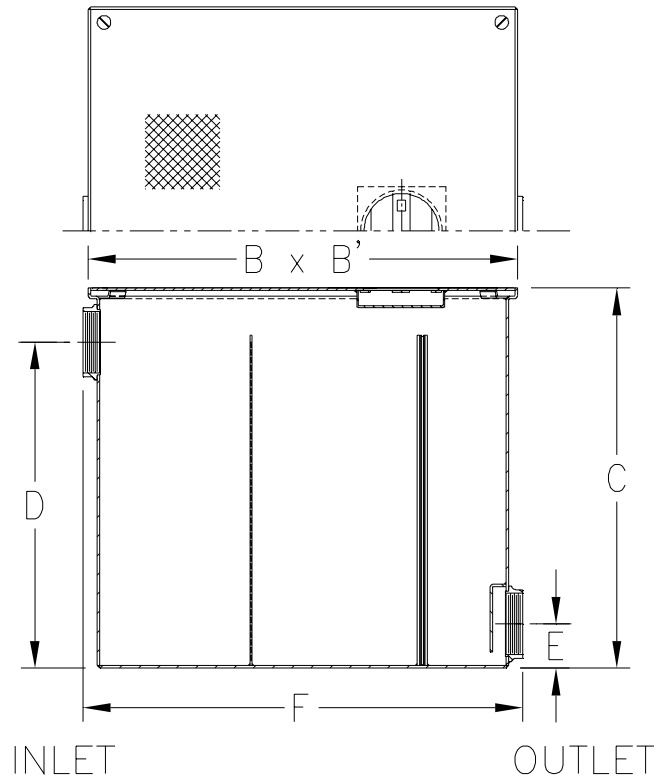

Size No. of Machines	Inlet/Outlet Size**	Flow Rate G.P.M. [L]	Approx. Wt. Lbs. [kg]	Dimensions In Inches					
				B	B'	C	D	E	F
3	2 [51]	30 [113]	93 [42]	17 [432]	17 [432]	16 1/2 [419]	13 1/2 [343]	3 1/4 [82]	17 1/4 [438]
7	3 [76]	70 [265]	155 [70]	25 [635]	25 [635]	20 [508]	17 [432]	3 1/4 [82]	25 1/2 [648]
10	4 [102]	100 [378]	271 [123]	33 [838]	33 [838]	28 [711]	25 [635]	4 [102]	34 [864]
20	4 [102]	200 [756]	404 [183]	40 [1016]	40 [1016]	35 [889]	32 [813]	4 [102]	41 [1041]
30	6 [152]	300 [1134]	654 [297]	45 [1143]	45 [1143]	40 [1016]	36 [914]	5 [127]	46 [1168]
40	6 [152]	400 [1512]	723 [328]	48 [1219]	48 [1219]	43 [1092]	39 [991]	5 [127]	49 [1245]
50	6 [152]	500 [1890]	911 [414]	52 [1321]	52 [1321]	47 [1194]	43 [1092]	5 [127]	53 [1346]

**ENGINEERING SPECIFICATION:** ZURN Z1185 Acid Resistant Coated interior and exterior fabricated steel lint interceptor, non-skid secured cover, with stainless lint intercepting secondary screen assembly and permanent primary straining baffle. Regularly furnished with high inlet and low outlet.

**OPTIONS** (Check/specify appropriate options)

**PREFIXES**

\_\_\_\_\_ Z Acid Resistant Coated Fabricated Steel\*

**SUFFIXES**

\_\_\_\_\_ -E Acid Resistant Coated interior and exterior fabricated steel extension section  
(Specify 'C' dimension required for recessed installation).

\_\_\_\_\_ -RS Stainless Steel Screen Replacement Assembly

<b>REV. D</b>	<b>DATE: 1/24/07</b>	<b>C.N. NO. 96102</b>
<b>DWG. NO. 58915</b>		<b>PRODUCT NO. Z1185</b>

\*REGULARLY FURNISHED UNLESS OTHERWISE SPECIFIED



# Z880 2-3/8" WIDE GRATES

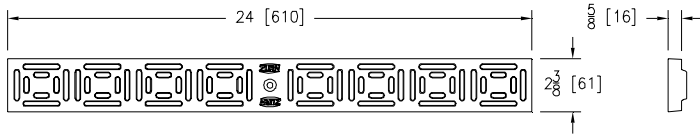

Please Check	Item No.
✓	1

AOG- Aluminum Decorative		
Material : Aluminum		
DIN Rating : Class A		
Weight: 1.12 # per ft.		
Open Area: 6.14 sq. in. per ft.		
ANSI Rating: Light Duty		
Application: Decorative Heelproof		
Slot Width/Hole Size: 0.25"		
ADA	H-20	FAA
Yes	No	No

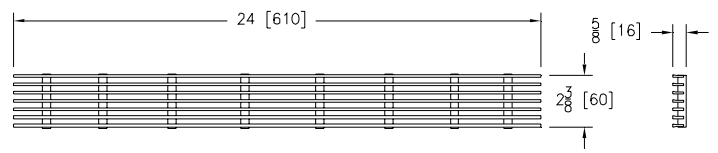

Please Check	Item No.
✓	2

AWG- Aluminum Wire		
Material : Aluminum		
DIN Rating : Class A		
Weight: .80 # per ft.		
Open Area: 15.00 sq. in. per ft.		
ANSI Rating: Light Duty		
Application: Decorative Heelproof		
Slot Width/Hole Size: 0.25"		
ADA	H-20	FAA
Yes	No	No

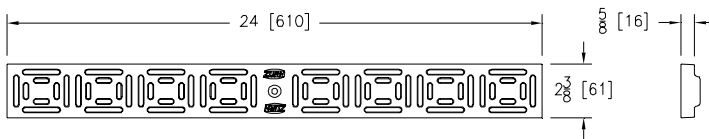

Please Check	Item No.
✓	3

BZ- Bronze Decorative		
Material : Bronze		
DIN Rating : Class A		
Weight: 3.00 # per ft.		
Open Area: 6.14 sq. in. per ft.		
ANSI Rating: Light Duty		
Application: Decorative Heelproof		
Slot Width/Hole Size: 0.25"		
ADA	H-20	FAA
Yes	No	No

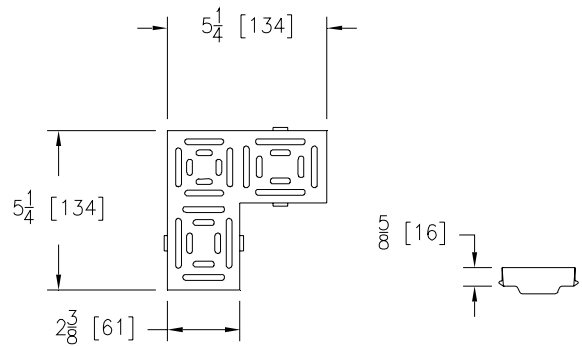

Please Check	Item No.
✓	4

G90- 90-Degree Plastic		
Material : Bronze		
DIN Rating : Class A		
Weight: .50 # per ft.		
Open Area: 10.22 sq. in. per ft.		
ANSI Rating: Light Duty		
Application: Decorative Heelproof		
Slot Width/Hole Size: 0.25"		
ADA	H-20	FAA
Yes	No	No



# Z880 2-3/8" WIDE GRATES

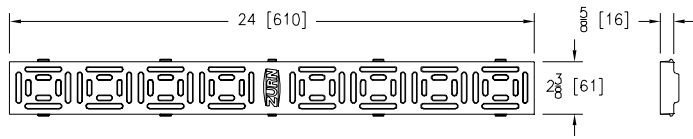

Please Check	Item No.
✓	5

POG- Heelproof Polyethylene Decorative		
Material : Polyethylene Plastic		
DIN Rating : Class A		
Weight: .50 # per ft.		
Open Area: 6.14 sq. in. per ft.		
ANSI Rating: Light Duty		
Application: Decorative Heelproof		
Slot Width/Hole Size: 0.25"		
ADA	H-20	FAA
Yes	No	No

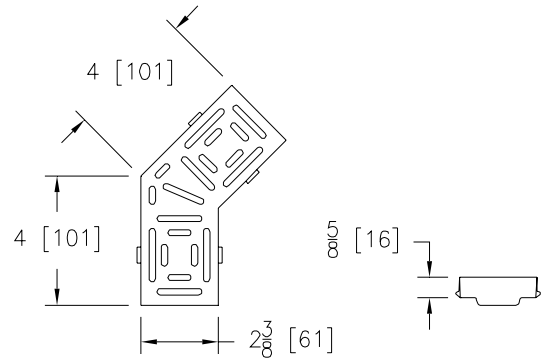

Please Check	Item No.
✓	6

S45- 45-Degree Plastic		
Material : Plastic		
DIN Rating : Class A		
Weight: .30 # per ft.		
Open Area: 5.28 sq. in. per ft.		
ANSI Rating: Light Duty		
Application: Decorative Heelproof		
Slot Width/Hole Size: 0.25"		
ADA	H-20	FAA
Yes	No	No

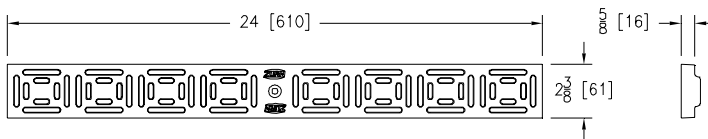

Please Check	Item No.
✓	7

SOG- Stainless Steel Decorative		
Material : Stainless Steel		
DIN Rating : Class A		
Weight: 2.75 # per ft.		
Open Area: 6.14 sq. in. per ft.		
ANSI Rating: Light Duty		
Application: Decorative Heelproof		
Slot Width/Hole Size: 0.25"		
ADA	H-20	FAA
Yes	No	No

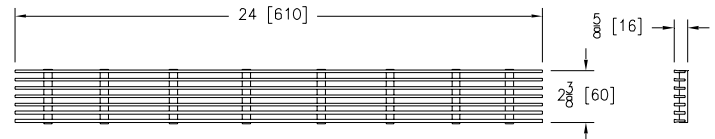

Please Check	Item No.
✓	8

SWG- Stainless Steel Wire		
Material : Aluminum		
DIN Rating : Class A		
Weight: 1.30 # per ft.		
Open Area: 15.00 sq. in. per ft.		
ANSI Rating: Light Duty		
Application: Decorative Heelproof		
Slot Width/Hole Size: 0.25"		
ADA	H-20	FAA
Yes	No	No

# RECOMMENDED PRODUCT SPECIFICATIONS

CHARLOTTE  
PIPE AND FOUNDRY COMPANY

## SUGGESTED SPECIFICATION

**System:** Hubless Cast Iron Soil Pipe and Fittings

**Scope:** This specification covers hubless Cast Iron pipe, fittings, and couplings used in sanitary drain, waste, and vent (DWV), sewer, and storm drainage applications. This system is intended for use in non-pressure applications.

**Specification:** Hubless Cast Iron pipe and fittings shall be manufactured from gray cast iron with a tensile strength of not less than 21,000 psi. Regular hubless couplings shall be shielded and conform to CISPI Standard 310 or ASTM C 1277, with an elastomeric gasket meeting the requirements of ASTM C 564. Heavy duty hubless couplings shall be shielded and conform to ASTM C 1540, with an elastomeric gasket meeting the requirements of ASTM C 564.

Pipe and fittings shall comply with ASTM A 888, and CISPI 301. Hubless couplings shall comply with ASTM C 564, and CISPI Standard 310 or ASTM C 1540. All pipe and fittings shall be made in the United States, and marked with the collective trademark of the Cast Iron Soil Pipe Institute, ©®. All pipe and fittings shall be of the same manufacturer. All systems shall utilize a separate waste and vent system.

Installation shall comply with the latest installation instructions published by Charlotte Pipe and Foundry and shall conform to all local plumbing, fire, and building code requirements. Joints shall be made with hubless couplings and tightened using a calibrated torque wrench. The system shall be hydrostatically (water) tested after installation to 4.3 psi. (10 feet of hydrostatic head). Testing with compressed air or gas is not recommended.

**Referenced Standards:**

ASTM A 888	Hubless Cast Iron Soil Pipe and Fittings
ASTM C 564	Rubber Gaskets for Cast Iron Soil Pipe and Fittings
CISPI 301	Hubless Cast Iron Soil Pipe and Fittings
CISPI 310	Hubless Couplings for Cast Iron Soil Pipe and Fittings
ASTM C 1277	Hubless Couplings
ASTM C 1540	Hubless Heavy Duty Couplings

Note: Latest revision of each standard applies.

PO Box 35430 Charlotte, NC 28235 USA 704/348-6450 800/572-4199 FAX 800/553-1605

[www.charlottepipe.com](http://www.charlottepipe.com)

# specification data

Specification data for hubless cast iron sanitary system with NO-HUB<sup>®</sup> pipe fittings. Standard No. 301-97.

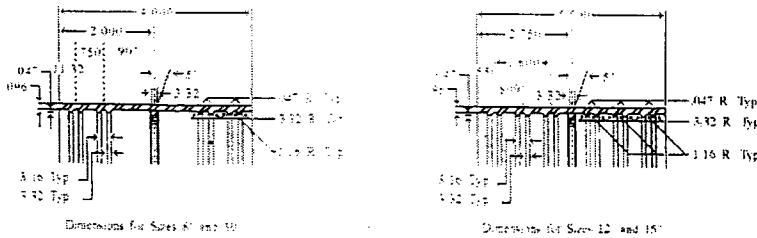
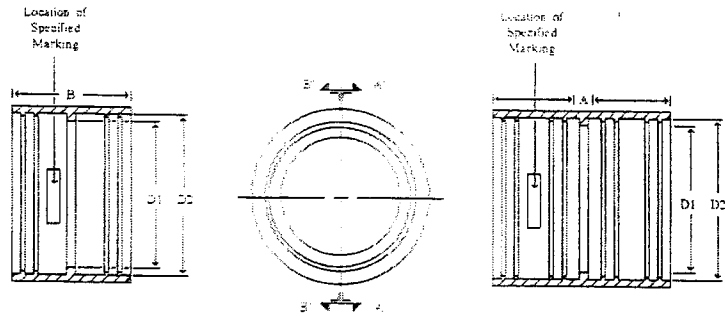
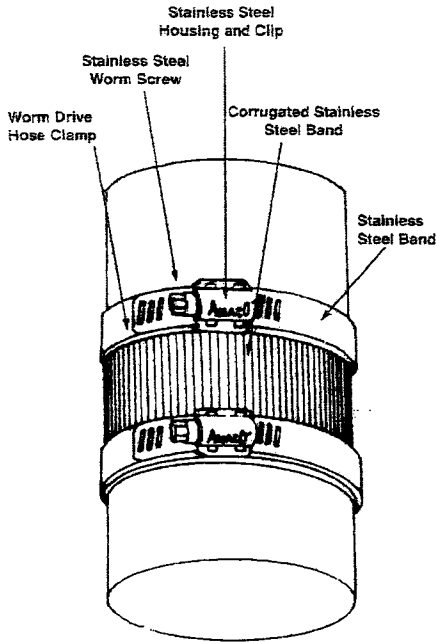

COUPLING BEFORE TIGHTENING

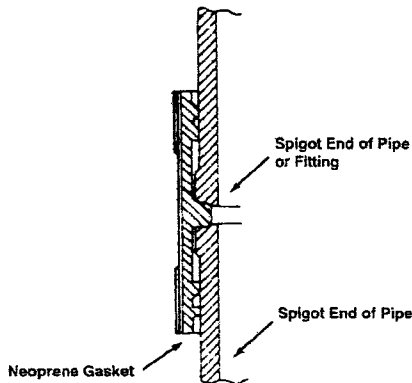

COUPLING AFTER TIGHTENING



DIMENSIONS IN INCHES										
	1 1/2"	2"	3"	4"	5"	6"	8"	10"	12"	15"
A	1.062	1.062	1.062	1.062	1.500	1.500	2.000	2.000	2.750	2.750
B	2.125	2.125	2.125	2.125	3.00	3.00	4.000	4.000	5.500	5.500
D <sub>1</sub>	1.531	1.968	2.968	4.000	4.968	5.968	7.968	9.975	12.000	15.200
D <sub>2</sub>	1.937	2.343	3.343	4.406	5.343	6.343	8.343	10.350	12.430	15.6500

## NO-HUB GASKET PHYSICAL REQUIREMENTS

### Detail

**Material:** The gasket shall be fabricated from a compound containing high-quality elastomer.

**Physical Tests:** The test specimens shall be obtained from finished gaskets in conformance with ASTM D 15.

### Tests

Test	Physical Tests Min. or Max Requirements	ASTM Method
Tensile Strength	1500 psi min.	D 412
Elongation	250 min.	D 412
Durometer (Shore A)	70 ± 5 @ 76°F ± 5°F	D 2240
Accelerated Aging	15% max. tensile and 20% max. elongation deterioration, 10 points max. increase in hardness, all determinations after oven aging for 96 hours at 158°F.	D 573
Compression Set	15% max. after 22 hours at 158°F.	D 395
Oil Immersion	80% max. volume change after immersion in ASTM oil no. 3 for 70 hours at 212°F.	Method B D 471
Ozone Cracking	No visible cracking at 2 times magnification of the gasket after 100 hours exposure in 1.5 ppm ozone concentration at 100°F. Testing and inspection to be on gasket which is loop mounted to give approximately 20% elongation of outer surface.	D 1149
Tear Resistance	Die C; 150 lbs. min. per inch of thickness.	D 624
Water Adsorption	20% max. by weight after 7 days at 158°F.	D 471

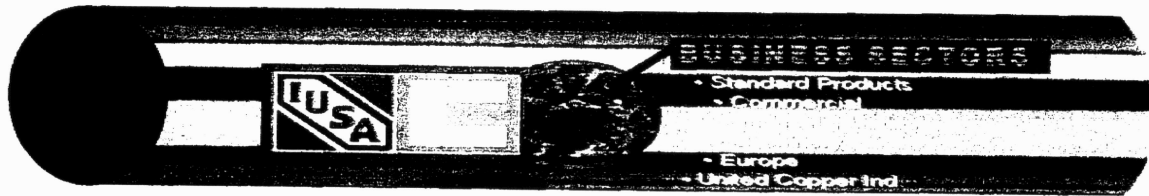

Home Up Feedback Contents

**Product Range Print**

**COPPER TUBE PRODUCT RANGE**

Cambridge-Lee Industries manufactures a wide range of copper tube products for use in the plumbing, refrigeration, air-conditioning, and commercial industries. Described herein is our current product range, but other items and specifications are continuously being added and may be available upon request.

Product	Application	Temper	Lengths	Color	Specifications
Water Tube Type K	Domestic Water Service Fire Protection Solar, Fuel Oil HVAC	Hard Soft	10 ft. Straight lgth 20 ft. Straight lgth 60 ft. Coils 100 ft. Coils	Green	C12200, ASTM B-88 Federal WW-T-799
Water Tube Type L	Domestic Water Service Fire Protection Solar, Fuel Oil HVAC, Natural Gas	Hard Soft	10 ft. Straight lgth 20 ft. Straight lgth 60 ft. Coils 100 ft. Coils	Blue	C12200, ASTM B-88 Federal WW-T-799
Water Tube Type M	Domestic Water Service Fire Protection Solar, Fuel Oil HVAC	Hard	10 ft. Straight lgth 20 ft. Straight lgth	Red	C12200, ASTM B-88 Federal WW-T-799
ACR Tube (L cleaned and capped/degreased)	Air Conditioning Refrigeration Natural Gas	Hard	20 ft. Straight lgth	Blue	C12200, ASTM B-280
OXY/MED Tube (K & L cleaned and capped/degreased)	Medical Gas Systems	Hard	20 ft. Straight lgth	Blue	C12200, ASTM B-280 B-819
Refrigeration Tube	Air Conditioning Refrigeration Service	Soft	50 ft. Coils 100 ft. Coils	Red	C12200, ASTM B-280
DWW Tube	Drainage	Hard	20 ft. Straight lgth	Yellow	C12200, ASTM B-306

Last modified: 06/11/07

DAMIEN W. SERAUSKAS, P.E.  
PROFESSIONAL ENGINEERING SERVICES

No Exceptions Taken       Rejected  
 Approved As Noted       Resubmit

Date: 3-18-09 By: [Signature]

Review is for general conformance with the design intent and general compliance with the information given in the Project Documents. The Contractor shall be responsible for confirming all dimensions, quantities, and installation methods.

HVAC + PLUMBING + FIRE PROTECTION + SITE UTILITIES

15 CYPRESS POINT LANE NEW ORLEANS, LA 70131  
VOICE: (504) 866-2600 FAX: (504)-218-8480



# CAMBRIDGE-LEE INDUSTRIES, LLC.

Reading Tube Division

P.O. Box 14026, Reading, PA 19612 - 4026

Phone 610 - 926 4141 Fax 610 - 926 7317

<b>Distributor:</b> <b>Address:</b> <b>Order No.:</b> <b>Product:</b>	<b>Customer:</b> <b>Address:</b> <b>P.O. No.:</b>
--	---

## Standard Tube Certificate of Conformance

Tube Type	Specification No. *	Specification Title
Type K, L & M	ASTM B 88 NSF 61	Standard Specification for Seamless Copper Water Tube ANSI/NSF Standard 61 Drinking Water System Components Health Effects <sup>1</sup>
Coils and Straight Lengths Marked as ACR	ASTM B 280	Standard Specification for Seamless Copper Tube for Air Conditioning and Refrigeration Field Service
Type DWV Drainage	ASTM B 306	Standard Specification for Copper Drainage Tube (DWV)
Type K & L Straight Lengths Marked as OXY/MED	ASTM B 819	Standard Specification for Seamless Copper Tube for Medical Gas Systems

Cambridge-Lee Industries, LLC certifies that the copper tube manufactured is grade UNS C12200 and meets the chemical, mechanical, cleanliness and eddy current testing requirements of the current specification(s) indicated below.

\* Although CLI - RTD strives to meet all requirements specified in ASTM, Standard Tube<sup>2</sup> may not fully meet ASTM dimensional requirements. When specified at order placement and for an additional cost, CLI - RTD can produce Certified Tube to meet all requirements of the current ASTM standard, including dimensions.

Copper tube manufactured by Cambridge-Lee Industries does not contain mercury or come in contact with mercury, mercury compounds or mercury containing devices at any stage in manufacturing, inspection, packaging or shipping.

All of the specifications require a minimum copper plus silver content of 99.9% and a phosphorus content between .015 - .040%. As indicated by the compositional requirements, the copper tube is essentially lead free.

<sup>1</sup> Seamless Copper Tube (Alloy C12200) is certified by NSF to NSF/ANSI Standard 61 for public water supplies meeting, or in process of meeting the U.S. EPA Lead and Copper Rule (56FR 26460, June 7, 1991). Water Supplies with pH less than 6.5 may require corrosion control to limit copper solubility in drinking water.

<sup>2</sup> Standard Tube will be provided unless Certified Tube is clearly defined on Purchase Order.



**PRODUCT CERTIFICATION - SOLDER, BRAZED AND THREADED COPPER  
AND COPPER ALLOY PLUMBING FITTINGS**

Elkhart Products Corporation manufactures and/or supplies products which meet the following specifications:

MSS	SP73	<u>Brazing Joints for Copper and Copper Alloy Pressure Fittings</u>
MSS	SP104	<u>Wrought Copper Solder Joint Pressure Fittings</u>
MSS	SP106	<u>Cast Copper Alloy Flanges and Flanged Fittings: Class 125, 150 and 300</u>
MSS	SP123	<u>Non-Ferrous Threaded and Solder-Joint Unions for use with Copper Water Tube</u>
MSS	SP109	<u>Welded Fabricated Copper Solder Joint Pressure Fittings</u>
ASME/ANSI	B16.29-2001:	<u>Wrought Copper and Wrought Copper Alloy Solder Joint Drainage Fittings - DWV</u>
ASME/ANSI	B16.18-2001:	<u>Cast Copper Alloy Solder Joint Pressure Fittings</u>
ASME/ANSI	B16.15-1994:	<u>Cast Bronze Threaded Fittings</u>
ASME/ANSI	B16.26-1988:	<u>Cast Copper Alloy Fittings for Flared Copper Tube</u>
ASME/ANSI	B16.23-2002:	<u>Cast Copper Alloy Solder Joint Drainage Fittings - DWV</u>
ASME/ANSI	B16.24-2001:	<u>Bronze Pipe Flanges and Flanged Fittings</u>

EPC's wrought copper solder joint fittings also are manufactured to comply with the material, performance, and installation/joining dimensions of ASME/ANSI B16.22. These fittings are also compliant with the European Union's RoHS (Restrictions of Hazardous Substances) Directive, 2002/95/EC.

The materials used to manufacture these fittings are also in compliance with the following specifications:

Tubular Wrought Copper: ASTM B75 Alloy C12200.	<u>Standard specification for Seamless Copper Tube, or</u>
Products Made From Sheet: ASTM B152 Alloy C11000.	<u>Standard Specification for Copper Sheet, Strip, Plate and Rolled Bar</u>
Cast Products: ASTM B584 Alloy C84400.	<u>Standard Specification for Copper Alloy Sand Castings for General Applications; Federal Specification WW-U-516 For Type III, Class A and B Copper Alloy Unions</u>

**ELKHART PRODUCTS CORPORATION**  
Plumbing Division



Dana Buccicone  
Director of Technology

State of Massachusetts product approval  
Number P1-0698-46, granted 6.3.98.

Subscribed and sworn to before me

On this 24<sup>th</sup> day of July, 2006

*Vicki A. Vergon*  
NOTARY PUBLIC

VICKI A. VERGON  
NOTARY PUBLIC STATE OF INDIANA  
OSCEOLA COUNTY  
MY COMMISSION EXPIRES FEB 28 2007

1255 Oak St. • P.O. Box 105 • Elkhart, Indiana 46515 • Tel: (574) 264-1051 • Fax: (574) 264-1052  
www.ElkhartProducts.com

an  
Alberis Industries  
company



**Elkhart Products Corporation**  
For the perfect fit



1255 Oak St. | Elkhart, Indiana 46515 | Ph: (574) 264-3181 | Fx: (574) 264-0103  
[www.elkhartproducts.com](http://www.elkhartproducts.com)

Publication Date: October 26, 2006  
Revision BB

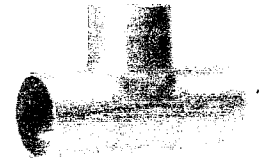

## RECYCLED MATERIAL FOR "LEED" COMPLIANCE Green Building Rating System

"Each year in the United States, nearly as much copper is recovered from recycled material as is derived from newly mined ore. Excluding wire production, more than three-fourths (¾) of the amount used by copper and brass mills, ingot makers, foundries, powder metal plants and other industries comes from recycled scrap copper."

"Almost half of all recycled copper scrap is old post consumer scrap, such as discarded electric cable, automobile radiators and air conditioners."

**Elkhart Products Corporation subscribes to the above facts and encourages its suppliers to do the same.**

The copper tubing and rod used to produce all E.P.C. copper fittings is manufactured from copper cathode which in turn is made up from twenty-five (25) percent post consumer scrap as described above. Another fifty (50) percent is post industrial scrap (turnings, shavings and chips).

Dennis Thompson

Staff Engineer  
Elkhart Products Corp.

an  
Aalberts Industries  
company

# Vulcan

THREADED PRODUCTS, INC.

Vulcan Threaded Products  
#10 Crosscreek Trail  
Pelham, AL 35124  
Ph:(205) 620-5100  
Fax:(205) 620-5150

Ref: Low Carbon All-Thread Rod

September 14, 2004

This letter is to certify that the All-Thread Rod supplied by Vulcan Threaded Products will meet the minimum physical requirements of ASTM A36 & A307 and produced to a 1A fit. 1/2" to 1" All-Thread Rod is produced from 1006/1008/1010 steel. 1-1/8" to 2-1/2" is produced from 1018 steel. The entire threaded rod size range is manufactured in the United States from domestic and foreign raw material.

All Hot-Dip Galvanized threaded rod is plated according to ASTM A153 specifications. All Zinc Threaded Rod is plated according to ASTM B633.

Best Regards,

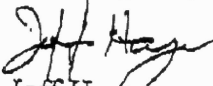

Jeff Hayes  
Purchasing Manager

DAMIEN W. SERAUSKAS, P.E.  
PROFESSIONAL ENGINEERING SERVICES

- No Exceptions Taken
- Rejected
- Approved As Noted
- Resubmit

Date: 3-18-09 By: 

Review is for general conformance with the design intent and general compliance with the information given in the Project Documents. The Contractor shall be responsible for confirming all dimensions, quantities, and installation methods.

HVAC + PLUMBING + FIRE PROTECTION + SITE UTILITIES

15 CYPRESS POINT LANE NEW ORLEANS, LA 70131  
VOICE: (504) 866-2600 FAX: (504)-218-8480

1/4" THROUGH 5/8" MANUFACTURED FROM 1006-1010 STEEL  
 3/4" THROUGH 1" MANUFACTURED FROM 1006 - 1010 OR A36 STEEL

ALL ALL-THREAD ROD WILL MEET MINIMUM TENSILE & YIELD  
 REQUIREMENTS OF ASTM A307 GRADE C

ITEM	MANUFACTURER	MATERIAL AS DESCRIBED ON INVOICE
1	VULCAN THREADED PRODUCTS	1/4"-20 LOW CARBON STEEL THREADED ROD MELTED DOMESTICALLY AND INTERNATIONALLY MANUFACTURED IN THE UNITED STATES
2	VULCAN THREADED PRODUCTS	5/16"-18 LOW CARBON STEEL THREADED ROD MELTED DOMESTICALLY AND INTERNATIONALLY MANUFACTURED IN THE UNITED STATES
3	VULCAN THREADED PRODUCTS	3/8"-16 LOW CARBON STEEL THREADED ROD MELTED DOMESTICALLY AND INTERNATIONALLY MANUFACTURED IN THE UNITED STATES
4	VULCAN THREADED PRODUCTS	1/2"-13 LOW CARBON STEEL THREADED ROD MELTED DOMESTICALLY AND INTERNATIONALLY MANUFACTURED IN THE UNITED STATES
5	VULCAN THREADED PRODUCTS	5/8"-11 LOW CARBON STEEL THREADED ROD MELTED DOMESTICALLY AND INTERNATIONALLY MANUFACTURED IN THE UNITED STATES
6	VULCAN THREADED PRODUCTS	3/4"-10 LOW CARBON STEEL THREADED ROD MELTED DOMESTICALLY AND INTERNATIONALLY MANUFACTURED IN THE UNITED STATES
7	VULCAN THREADED PRODUCTS	7/8"-09 LOW CARBON STEEL THREADED ROD MELTED AND MANUFACTURED IN THE UNITED STATES
8	VULCAN THREADED PRODUCTS	1"-08 LOW CARBON STEEL THREADED ROD MELTED AND MANUFACTURED IN THE UNITED STATES

ITEM	HEAT#	CARBON	MANG.	PHOS.	SULPHUR	SILICON	CHROM.	NICKEL	MOLY.	COPPER
1	65800	.06	.47	.006	.010	.15	.06	.09	.02	.20
2	64241	.06	.45	.011	.024	.12	.15	.10	.03	.26
3	26863	.06	.40	.016	.025	.12	.13	.14	.00	.26
4	26864	.07	.42	.013	.02	.13	.10	.11	.00	.21
5	1030122	.04	.45	.018	.034	.11	--	--	--	--
6	65197	.17	.67	.014	.016	.18	.14	.10	.03	.32
7	62286	.22	.90	.006	.025	.23	.05	.07	.02	.16
8	62260	.15	.72	.012	.026	.19	.07	.08	.02	.21

ITEM	HEAT #	TENSILE PSI	YIELD PSI	%ELONGATION 1" GAGE	REDUCTION OF AREA	BEND TEST
1	65800	62,200	40,053	36.0	-----	-----
2	64241	61,500	40,611	34.0	-----	-----
3	26863	60,915	40,053	36.0	-----	-----
4	26864	61,641	40,611	34.0	-----	-----
5	1030122	58,853	39,885	40.0	-----	-----
6	65197	73,700	51,200	32.0	-----	-----
7	62286	78,600	50,700	31.0	-----	-----
8	62260	69,100	45,800	37.0	-----	-----

WE HEREBY CERTIFY THAT THE FOREGOING DATA IS A TRUE COPY OF THE DATA FURNISHED BY THE PRODUCING MILL. ALL DATA SUPPLIED IN THIS ABOVE TEST REPORT ARE TYPICAL OF MATERIAL FURNISHED BY VULCAN THREADED PRODUCTS.

DATE: 4/30/2004

VULCAN THREADED PRODUCTS  
 #10 CROSSCREEK TRAIL  
 PELHAM, AL 35124  
 205 620-5100  
 FAX 205 620-5150

By: [Signature]  
 AUTHORIZED AGENT  
 QUALITY CONTROL SUPERVISOR

SEP-12-2007 12:25

VULCAN THREADED PRODUCTS

1-1/8" THROUGH 2" MANUFACTURED FROM 1018 OF A36 STEEL  
 2-1/4" THROUGH 2-1/2" MANUFACTURED FROM 1018 OF A36 STEEL

ALL ALL-THREAD ROD WILL MEET MINIMUM PHYSICAL AND  
 CHEMICAL REQUIREMENTS OF ASTM A307 GRADE C

ITEM	MANUFACTURER	MATERIAL AS DESCRIBED ON INVOICE
1	VULCAN THREADED PRODUCTS	1-1/8"-7 LOW CARBON STEEL THREADED ROD MELTED AND MANUFACTURED IN THE UNITED STATES
2	VULCAN THREADED PRODUCTS	1-1/4"-7 LOW CARBON STEEL THREADED ROD MELTED AND MANUFACTURED IN THE UNITED STATES
3	VULCAN THREADED PRODUCTS	1-3/8"-6 LOW CARBON STEEL THREADED ROD MELTED AND MANUFACTURED IN THE UNITED STATES
4	VULCAN THREADED PRODUCTS	1-1/2"-6 LOW CARBON STEEL THREADED ROD MELTED AND MANUFACTURED IN THE UNITED STATES
5	VULCAN THREADED PRODUCTS	1-3/4"-5 LOW CARBON STEEL THREADED ROD MELTED AND MANUFACTURED IN THE UNITED STATES
6	VULCAN THREADED PRODUCTS	2"-4.5 LOW CARBON STEEL THREADED ROD MELTED AND MANUFACTURED IN THE UNITED STATES
7	VULCAN THREADED PRODUCTS	2-1/4"-4 LOW CARBON STEEL THREADED ROD MELTED AND MANUFACTURED IN THE UNITED STATES
8	VULCAN THREADED PRODUCTS	2-1/2"-4 LOW CARBON STEEL THREADED ROD MELTED AND MANUFACTURED IN THE UNITED STATES

ITEM	HEAT#	CARBON	MANG	PHOS.	SULPHUR	SILICON	CHROM.	NICKEL	MOLY.	COPPER
1	589911120	.20	.80	.015	.026	.22	.10	.09	.03	.43
2	589915771	.17	.70	.02	.036	.16	.12	.10	.04	.41
3	319913248	.20	.60	.012	.040	.21	.11	.09	.04	.37
4	319913251	.18	.60	.012	.037	.21	.13	.10	.04	.33
5	151115	.14	.78	.008	.023	.21	.07	.15	.034	.37
6	151438	.17	.82	.005	.017	.23	.06	.09	.016	.21
7	681952	.18	.77	.01	.03	.22	-----	-----	-----	-----
8	640723	.18	.70	.02	.04	.22	-----	-----	-----	-----

HEAT #	TENSILE PSI MIN	YIELD PSI MIN	%ELONGATION 8" GAGE MIN %	REDUCTION OF AREA MIN %
589911120	77,400	52,100	27	-----
589915771	72,400	49,600	24	-----
319913248	71,338	48,408	25	-----
319913251	75,796	48,408	23	-----
151115	68,000	46,900	47	-----
151438	70,100	49,700	52	-----
681952	92,300	85,400	16	-----
640723	89,500	80,550	15	-----

WE HEREBY CERTIFY THAT THE FOREGOING DATA IS A TRUE COPY OF THE DATA FURNISHED BY THE PRODUCING MILL.  
 ALL DATA SUPPLIED IN THE ABOVE TEST REPORT ARE TYPICAL OF MATERIAL FURNISHED BY VULCAN THREADED PRODUCTS.

DATE: 9/13/2003

**VULCAN THREADED PRODUCTS**  
 #10 CROSSCREEK TRAIL  
 PELHAM, AL 35124  
 (205) 620-5100  
 FAX (205) 620-5150

BY: [Signature]  
 AUTHORIZED AGENT  
 QUALITY CONTROL SUPERVISOR



**SUBMITTAL**  
**A-135D**

**JOB:** SOF RIVERINE & COMBATANT CRAFT OPER. FAC. **REPRESENTATIVE:** Hydronic Technology, Inc.

**UNIT TAG:**  
**ENGINEER:**  
**CONTRACTOR:** GALLO MECHANICAL

**ORDER NO.**  
**SUBMITTED BY:** BILLY MARTINEZ  
**APPROVED BY:**

**DATE:** 5/1/2009  
**DATE:**  
**DATE:**

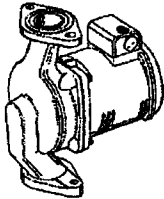

**SERIES PL™**  
**Permanently Lubricated**  
**Iron & Bronze Booster Pumps**



**DESCRIPTION**

The Series PL™ close coupled booster pumps are specifically designed for quiet operation in hydronic, radiant and geothermal heating and cooling systems. These inline permanently lubricated pumps are available in cast iron or bronze body construction.

**OPERATING DATA**

Maximum working Pressure: 150 psi (10 Bar)  
Maximum Operating Temperature: 225°F (107°C)

**CONSTRUCTION MATERIALS**

Booster Body: Cast Iron or Bronze  
Face Plate: Stainless Steel  
Impeller: 30% Glass Filled Noryl®  
(PL-55 & PL-130): Glass Filled PPS  
Shaft: Carbon Steel  
(PL-55 & PL-130): Stainless Steel  
Shaft Sleeve: Stainless Steel  
(PL-55 & PL-130): None  
Seal: Mechanical, Carbon on Silicon Carbide  
Motor Bearings: Sealed Precision Steel Ball Bearing  
Permanently Lubricated  
Motor Type: ODP  
Elastomers: EPDM

**SCHEDULE**

CAST IRON			BRONZE			STANDARD 60 CYCLE SINGLE PHASE MOTOR CHARACTERISTICS				TAGGING INFORMATION
MODEL NUMBER	PART NUMBER	QTY.	MODEL NUMBER	PART NUMBER	QTY.	HP	VOLTAGE	F.L. AMPS	RPM	
PL-30	1BL012		PL-30B	1BL013	1	1/12	115	1.4	2650	REC-1
PL-30	1BL014		PL-30B	1BL015		1/12	230	0.8	2650	
PL-36	1BL001		PL-36B	1BL003		1/6	115	2.1	3300	
PL-36	1BL006		PL-36B	1BL008		1/6	230	1.1	3300	
PL-45	1BL002		PL-45B	1BL004		1/6	115	2.1	3300	
PL-45	1BL007		PL-45B	1BL009		1/6	230	1.1	3300	
PL-50	1BL016		PL-50B	1BL017		1/6	115	1.8	3300	
PL-50	1BL018		PL-50B	1BL019		1/6	230	1.0	3300	
PL-55	1BL032		PL-55B	1BL068		2/5	115	4.7	3250	
PL-55	1BL033		PL-55B	1BL069		2/5	230	2.4	3250	
PL-75	1BL034		PL-75B	1BL035		1/6	115	2.1	3400	
PL-75	1BL036		PL-75B	1BL037		1/6	230	1.1	3400	
PL-130/2"	1BL063		PL-130B/2"	1BL065		2/5	115	4.8	3200	
PL-130/2"	1BL064		PL-130B/2"	1BL066		2/5	230	2.4	3200	
PL-130/3"	1BL070		PL-130B/3"	1BL072		2/5	115	4.8	3200	
PL-130/3"	1BL071		PL-130B/3"	1BL073		2/5	230	2.4	3200	

Note: Where potable water is pumped, use a bronze booster.  
PL boosters equipped with a drip-proof motor are recommended for indoor use only.

**SERIES PL - Permanently Lubricated Booster Pumps**

A-

**DIMENSIONS AND WEIGHTS**

MODEL NO.	FLANGE SIZE INCHES - NPT	MOTOR HP	DIMENSIONS - INCHES (mm)					APPROX SHIPPI V (KG)
			A	B	C	D	E	
PL-30	3/4, 1, 1-1/4 & 1-1/2	1/12	8 5/8 (219)	6 3/8 (162)	7 1/8 (181)	4 3/16 (108)	4 3/8 (111)	11.6 (E)
PL-36	3/4, 1, 1-1/4 & 1-1/2	1/8	8 5/8 (219)	6 3/8 (162)	7 1/8 (181)	4 3/16 (106)	4 3/8 (111)	13.1 (E)
PL-45	1, 1-1/4 & 1-1/2	1/8	9 1/8 (232)	8 1/2 (216)	7 1/4 (184)	4 5/8 (117)	4 1/2 (114)	14.5 (E)
PL-50	1, 1-1/4 & 1-1/2	1/8	9 1/8 (232)	8 1/2 (216)	7 1/4 (184)	4 5/8 (117)	4 1/2 (114)	14.5 (E)
PL-55	3/4, 1, 1-1/4 & 1-1/2	2/5	9 9/16 (243)	6 3/8 (162)	7 15/16 (202)	4 3/16 (108)	4 3/4 (121)	13.1 (E)
PL-75	2	1/8	9 15/16 (252)	8 1/2 (216)	7 3/8 (187)	5 3/16 (132)	4 5/8 (117)	18.5 (E)
PL-130/2"	2	2/5	10 3/4 (273)	8 1/2 (216)	8 1/4 (210)	5 3/16 (132)	5 1/8 (130)	22 (1)
PL-130/3"	3	2/5	10 3/4 (273)	8 1/2 (216)	8 1/4 (210)	6 (152)	5 1/8 (130)	27 (12)

Dimensions are approximate and subject to change. Contact factory for certified dimensions.

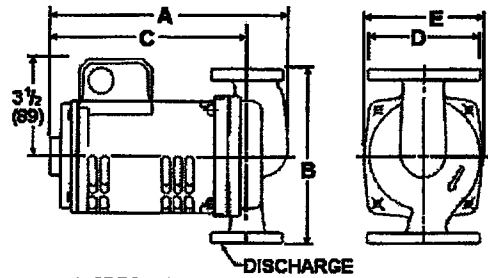

**TYPICAL SPECIFICATIONS**

The contractor shall furnish and install inline pumps as illustrated on the plans and in accordance with the following specifications:

1. The pumps shall be of the horizontal, permanently lubricated type, specifically designed and guaranteed for quiet operation.
2. The pumps shall have a steel shaft supported by permanently lubricated, sealed precision ball bearings. The pumps are to be equipped with a water-tight seal to prevent leakage. Mechanical seal faces to be carbon on silicon carbide. The motor shall be non-overloading at any point on the pump performance curve.
3. The motor shall be of the drip-proof, sealed precision ball-bearing, quiet-operating construction. The permanent split-capacitor motor shall be equipped with thermal overload protection.
4. Pumps to be suitable for 225°F (107°C) operating temperature at 150 psig (10 bar) working pressure. The pumps shall be ITT Bell & Gossett Model No. PL-\_\_\_\_\_ with a capacity of \_\_\_\_\_ GPM at \_\_\_\_\_ feet of head.

**PERFORMANCE CHARACTERISTICS CURVES**

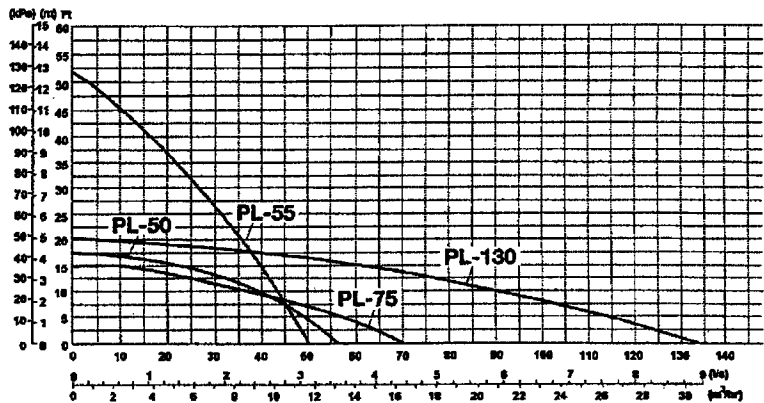
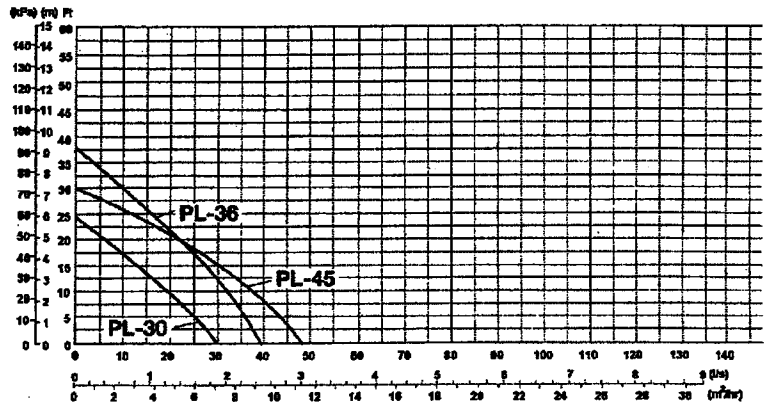

ITT  
 8200 N. Austin Avenue  
 Morton Grove, IL 60053  
 Phone (847)966-3700  
 Facsimile (847)966-9052  
 www.bellgossett.com

