

SECTION 23 09 23

DIRECT DIGITAL CONTROL FOR HVAC AND OTHER LOCAL BUILDING SYSTEMS
11/08

PART 1 GENERAL

1.1 REFERENCES

The publications listed below form a part of this specification to the extent referenced. The publications are referred to within the text by the basic designation only.

AIR MOVEMENT AND CONTROL ASSOCIATION INTERNATIONAL (AMCA)

AMCA 500-D (1998) Laboratory Methods of Testing
Dampers for Rating

ASME INTERNATIONAL (ASME)

ASME B16.15 (2006) Cast Bronze Threaded Fittings
Classes 125 and 250

ASME B16.34 (2004) Valves - Flanged, Threaded and
Welding End

ASME B40.100 (2005) Pressure Gauges and Gauge
Attachments

ASTM INTERNATIONAL (ASTM)

ASTM A 269 (2008) Standard Specification for Seamless
and Welded Austenitic Stainless Steel
Tubing for General Service

ASTM B 88 (2003) Standard Specification for Seamless
Copper Water Tube

ASTM B 88M (2005) Standard Specification for Seamless
Copper Water Tube (Metric)

ASTM D 1693 (2008) Standard Test Method for
Environmental Stress-Cracking of Ethylene
Plastics

ASTM D 635 (2006) Standard Test Method for Rate of
Burning and/or Extent and Time of Burning
of Self-Supporting Plastics in a
Horizontal Position

CONSUMER ELECTRONICS ASSOCIATION (CEA)

CEA-709.1B (2002) Control Network Protocol
Specification

CEA-709.3 (1999) Free-Topology Twisted-Pair Channel Specification

CEA-852-A (2004) Tunneling Component Network Protocols Over Internet Protocol Channels

FLUID CONTROLS INSTITUTE (FCI)

FCI 70-2 (2006) Control Valve Seat Leakage

INSTITUTE OF ELECTRICAL AND ELECTRONICS ENGINEERS (IEEE)

IEEE C62.41.1 (2002) IEEE Guide on the Surges Environment in Low-Voltage (1000 V and Less) AC Power Circuits

IEEE C62.41.2 (2002) IEEE Recommended Practice on Characterization of Surges in Low-Voltage (1000 V and Less) AC Power Circuits

IEEE Std 142 (2007) Recommended Practice for Grounding of Industrial and Commercial Power Systems - IEEE Green Book (Color Book Series)

LONMARK INTERNATIONAL (LonMark)

LonMark Interoperability Guide (2002) LonMark Application-Layer Interoperability Guide; Version 3.3

NATIONAL ELECTRICAL MANUFACTURERS ASSOCIATION (NEMA)

NEMA 250 (2003) Enclosures for Electrical Equipment (1000 Volts Maximum)

NATIONAL FIRE PROTECTION ASSOCIATION (NFPA)

NFPA 70 (2007; AMD 1 2008) National Electrical Code - 2008 Edition

NFPA 90A (2008) Standard for the Installation of Air Conditioning and Ventilating Systems

UNDERWRITERS LABORATORIES (UL)

UL 1585 (1998; Rev thru May 2006) UL Standard for Safety Class 2 and Class 3 Transformers - Fourth Edition

UL 94 (1996; Rev thru Jun 2006) Tests for Flammability of Plastic Materials for Parts in Devices and Appliances

1.2 DEFINITIONS

The following list of definitions may contain terms not found elsewhere in the Section but are included here for completeness.

- a. Application Specific Controller: A device that is furnished with a pre-established built in application that is configurable but not re-programmable. An ASC has a fixed factory-installed application program (i.e Program ID) with configurable settings.
- b. Binary: A two-state system where an "ON" condition is represented by a high signal level and an "OFF" condition is represented by a low signal level. 'Digital' is sometimes used interchangeably with 'binary'.
- c. Binding: The act of establishing communications between CEA-709.1B devices by associating the output of a device to the input of another.
- d. Building Control Network: The CEA-709.1B control network installed under this Section, consisting of a backbone and one or more local control busses.
- e. Building Point of Connection (BPOC): The BPOC is the point of connection between the UMCS network backbone (an IP network) and the building control network backbone. The hardware at this location, that provides the connection is referred to as the BPOC Hardware. In general, the term "BPOC Location" means the place where this connection occurs, and "BPOC Hardware" means the device that provides the connection. Sometimes the term "BPOC" is used to mean either and its actual meaning (i.e. location or hardware) is determined by the context in which it is used.
- f. Channel: A portion of the control network consisting of one or more segments connected by repeaters. Channels are separated by routers. The device quantity limitation is dependent on the topology/media and device type. For example, a TP/FT-10 network with locally powered devices is limited to 128 devices per channel.
- g. Configuration Parameter: Controller setting usually written to EEPROM. Also see 'Standard Configuration Parameter Type (SCPT)'
- h. Control Logic Diagram: A graphical representation of control logic for multiple processes that make up a system.
- i. Domain: A grouping of up to 32,385 nodes that can communicate directly with each other. (Devices in different domains cannot communicate directly with each other.) Part of the Node Addressing scheme.
- j. Explicit Messaging: A method of communication between devices where each message contains a message code that identifies the type of message and the devices use these codes to determine the action to take when the message is received. These messages are non-standard and often vendor (application) dependent.
- k. External Interface File (XIF): A file which documents a device's external interface, specifically the number and types of LonMark objects; the number, types, directions, and connection attributes of network variables; and the number of message tags.
- l. Functional Profile: The description of one or more LonMark Objects used to classify and certify devices.

- m. Gateway: A device that translates from one protocol to another. Gateways are also called Communications Bridges or Protocol Translators.
- n. General Purpose Programmable Controller (GPPC): Unlike an ASC, a GPPC is not furnished with a fixed application program. A GPPC can be (re-)programmed, usually using vendor-supplied software.
- o. LonMark Object: A collection of network variables, configuration parameters, and associated behavior defined by LonMark International and described by a Functional Profile. Defines how information is exchanged between devices on a network (inputs from and outputs to the network).
- p. LNS Plug-in: Software which runs in an LNS compatible software tool. Device configuration plug-ins provide a 'user friendly' interface to configuration parameters.
- q. LonMark: See LonMark International. Also, a certification issued by LonMark International to CEA-709.1B devices.
- r. LonMark International: Standards committee consisting of numerous independent product developers and systems integrators dedicated to determining and maintaining the interoperability guidelines for the LonWorks industry. Maintains guidelines for the interoperability of CEA-709.1B devices and issues the LonMark Certification for CEA-709.1B devices.
- s. LonMark Interoperability Association: See 'LonMark International'.
- t. LonWorks: The overall communications technology, developed by Echelon Corporation, for control systems. The term is often used to refer to the technology in general, and may include reference to any/all of the: protocol, network management, and interoperability guidelines where the technology is based on the CEA-709.1B protocol and employs interoperable devices along with the capability to openly manage these devices (via multiple vendors) using a network configuration (or service) tool.
- u. LonWorks Network Services (LNS): A network management and database standard for CEA-709.1B devices.
- v. Monitoring and Control (M&C) Software: The UMCS 'front end' software which performs supervisory functions such as alarm handling, scheduling and data logging and provides a user interface for monitoring the system and configuring these functions.
- w. Network Variable: See 'Standard Network Variable Type (SNVT)'.
- x. Network Configuration Tool: The software used to configure the control network and set device configuration properties. This software creates and modifies the control network database (LNS Database).
- y. Node: A device that communicates using the CEA-709.1B protocol and is connected to an CEA-709.1B network.
- z. Node Address: The logical address of a node on the network. Variations in node addressing are possible, but the 'Domain, Subnet,

Node' format is the established standard for this specification.

aa. Node ID: A unique 48-bit identifier assigned (at the factory) to each CEA-709.1B device, sometimes called the Neuron ID.

bb. Program ID: An identifier (number) stored in the device (usually EEPROM) that identifies the node manufacturer, functionality of device (application & sequence), transceiver used, and the intended device usage.

cc. Repeater: A device that connects two control network segments and retransmits all information received on one side onto the other.

dd. Router: A device that connects two channels and controls traffic between the channels by retransmitting signals received from one subnet onto the other based on the signal destination. Routers are used to subdivide a control network and to control bandwidth usage.

ee. Segment: A 'single' section of a control network that contains no repeaters or routers. The device quantity limitation is dependent on the topology/media and device type. For example, a TP/FT-10 network with locally powered devices is limited to 64 devices per segment.

ff. Service Pin: A hardware push-button on a device which causes the device to broadcast a message (over the control network) containing its Node ID and Program ID. This broadcast can also be initiated via software.

gg. Standard Configuration Parameter Type (SCPT): Pronounced 'skip-it'. A standard format type (maintained by LonMark International) for Configuration Parameters.

hh. Standard Network Variable Type (SNVT): Pronounced 'snivet'. A standard format type (maintained by LonMark International) used to define data information transmitted and received by the individual nodes. The term SNVT is used in two ways. Technically it is the acronym for Standard Network Variable Type, and is sometimes used in this manner. However, it is often used to indicate the network variable itself (i.e. it can mean "a network variable of a standard network variable type"). In general, the intended meaning should be clear from the context.

ii. Subnet: Consists of a logical (not physical) grouping of up to 127 nodes, where the logical grouping is defined by node addressing. Part of the Node Addressing scheme.

jj. TP/FT-10: A Free Topology Twisted Pair network defined by CEA-709.3. This is the most common media type for an ANSI-709.1 control network.

kk. UMCS Network: An IP network connecting multiple building level control networks using the CEA-852-A standard.

ll. User-defined Configuration Parameter Type (UCPT): Pronounced 'u-keep-it'. A Configuration Parameter format type that is defined by the device manufacturer.

mm. User-defined Network Variable Type (UNVT): A network variable

format defined by the device manufacturer. Note that UNVTs create non-standard communications (other vendor's devices may not correctly interpret it) and may close the system and therefore are not permitted by this specification.

1.3 SYSTEM DESCRIPTION

Provide a Direct Digital Control (DDC) system as a complete system suitable for the control of the heating, ventilating and air conditioning (HVAC) and other building-level systems as specified and shown.

1.3.1 System Requirements

Systems installed under this guide specification shall have the following characteristics:

System shall be a Siemens APOGEE(R) Network system compatible with the existing DDC systems in place at Stennis Space Center. Reference Shop Drawings and product data submittals for detailed information.

1.4 SUBMITTALS

Government approval is required for submittals with a "G" designation; submittals not having a "G" designation are for Contractor Quality Control approval.

a. Technical data packages consisting of technical data and computer software (meaning technical data which relates to computer software) which are specifically identified in this project and which may be defined/required in other specifications shall be delivered strictly in accordance with the CONTRACT CLAUSES and in accordance with the Contract Data Requirements List, DD Form 1423. Data delivered shall be identified by reference to the particular specification paragraph against which it is furnished. All submittals not specified as technical data packages are considered 'shop drawings' under the Federal Acquisition Regulation Supplement (FARS) and shall contain no proprietary information and be delivered with unrestricted rights.

b. Submit the following in accordance with Section 01 33 00 SUBMITTAL PROCEDURES, the CONTRACT CLAUSES and DD Form 1423 and according to the sequencing specified in paragraph PROJECT SEQUENCING:

SD-02 Shop Drawings

DDC Contractor Design Drawings; G

DDC Contractor Design Drawings in hard copy and on CDROM in AutoCAD format.

Final As-Built Drawings; G

Final As-Built Drawings in hard copy and on CDROM in AutoCAD format.

SD-03 Product Data

Manufacturer's Catalog Data; G

Product specific catalog cuts for each product provided under this specification.

Programming Software; G

The most recent version of the Programming software for each type (manufacturer and model) of General Purpose Programmable Controller (GPPC) as a Technical Data Package licensed to the project site. Software on CD-ROM and 2 hard copies of the software user manual for each piece of software provided.

SD-06 Test Reports

Post-Construction QC Checklist; G

Four copies of the Post-Construction QC Checklist.

SD-10 Operation and Maintenance Data

Operation and Maintenance (O&M) Instructions; G

2 copies of the Operation and Maintenance Instructions, indexed and in booklet form. The Operation and Maintenance Instructions shall be a single volume or in separate volumes, and may be submitted as a Technical Data Package.

Training Documentation; G

Deliver training manuals for each trainee on the Course Attendee List with 2 additional copies delivered for archival at the project site. Deliver 2 copies of the Course Attendee List with the archival copies. The Training Documentation may be submitted as a Technical Data Package.

SD-11 Closeout Submittals

Closeout QC Checklist; G

Four copies of the Closeout QC Checklist.

1.5 QUALITY ASSURANCE

1.5.1 QUALITY CONTROL (QC) CHECKLISTS

The Contractor's Chief Quality Control (QC) Representative shall complete the QC Checklist in APPENDIX A and submit a Pre-Construction QC Checklist, Post-Construction QC Checklist and a Closeout QC Checklist as specified. The QC Representative shall verify each item in the Checklist and initial in the provided area to indicate that the requirement has been met. The QC Representative shall sign and date the Checklist prior to submission to the Government.

1.5.2 Surge Protection

1.5.2.1 Power-Line Surge Protection

Protect equipment connected to ac circuits against or withstand power-line

surges. Equipment protection shall meet the requirements of IEEE C62.41.1, IEEE C62.41.2. Fuses shall not be used for surge protection.

1.5.2.2 Surge Protection for Transmitter and Control Wiring

Protect DDC hardware against or withstand surges induced on control and transmitter wiring installed outdoors and as shown. The equipment protection shall be protected against the following two waveforms:

- a. A waveform with a 10-microsecond rise time, a 1,000-microsecond decay time and a peak current of 60 amps.
- b. A waveform with an 8-microsecond rise time, a 20-microsecond decay time and a peak current of 500 amperes.

1.5.3 Input Measurement Accuracy

Select, install and configure sensors, transmitters and DDC Hardware such that the maximum error of the measured value at the SNVT output of the DDC hardware is less than 150 percent of the maximum allowable error specified for the sensor or instrumentation.

1.5.4 System Modifications

Submit recommendations for system modification in writing. No system modifications, including operating parameters and control settings, shall be made without prior approval of the Government. Incorporate any modifications made to the system into the Operations and Maintenance Instructions, and other documentation affected.

1.5.5 Drawings

The Government will not indicate all offsets, fittings, and accessories that may be required on the drawings. Carefully investigate the mechanical, electrical, and finish conditions that could affect the work to be performed, arrange such work accordingly, and provide all work necessary to meet such conditions. Drawings shall be on [ISO A1 34 by 22 inches][or][A3 17 by 11 inches] sheets in the form and arrangement shown. Use in the drawings the same abbreviations, symbols, nomenclature and identifiers shown. Each control system element on a drawing shall be assigned a unique identifier as shown. Deliver the DDC Contractor Design Drawings together as a complete submittal. Deviations shall be approved by the Contracting Officer. DDC Contractor Design Drawings shall include the following:

- a. Drawing Index and HVAC Design Drawing Legend: The HVAC Control System Drawing Index shall show the name and number of the building, military site, State or other similar designation, and Country. The Drawing Index shall list all Contractor Design Drawings, including the drawing number, sheet number, drawing title, and computer filename when used. The Design Drawing Legend shall show and describe all symbols, abbreviations and acronyms used on the Design Drawings.
- b. Valve Schedule: The valve schedule shall contain each valve's unique identifier, size, flow coefficient Kv (Cv), pressure drop at specified flow rate, spring range, positive positioner range, actuator size, close-off pressure to torque data, dimensions, and access and clearance requirements data. The valve schedule shall contain actuator

selection data supported by calculations of the force required to move and seal the valve, access and clearance requirements. A valve schedule shall be submitted for each HVAC system.

c. Damper Schedule: The damper schedule shall contain each damper's unique identifier, type (opposed or parallel blade), nominal and actual sizes, orientation of axis and frame, direction of blade rotation, actuator size and spring ranges, operation rate, positive positioner range, location of actuators and damper end switches, arrangement of sections in multi-section dampers, and methods of connecting dampers, actuators, and linkages. The Damper Schedule shall include the AMCA 500-D maximum leakage rate at the operating static-pressure differential. A damper schedule shall be submitted for each HVAC system.

d. Thermostat and Occupancy Sensor Schedule: The thermostat and occupancy sensor schedule shall contain each thermostat's unique identifier, room identifier and control features and functions as shown. A thermostat and occupancy sensor schedule shall be submitted for each HVAC system.

e. Critical Alarm Handling Schedule: The critical alarm handling schedule shall contain the same fields as the critical alarm handling schedule Contract Drawing with Contractor updated information and any other project-specific information required to implement the alarm handling function. A critical alarm handling schedule shall be submitted for each HVAC system.

f. Equipment Schedule: The equipment schedule shall contain the unique identifier, manufacturer, model number, part number and descriptive name for each control device, hardware and component provided under this specification. An equipment schedule shall be submitted for each HVAC system.

g. Occupancy Schedule: The occupancy schedule drawing shall contain the same fields as the occupancy schedule Contract Drawing with Contractor updated information. An occupancy schedule shall be submitted for each HVAC system.

h. Points Schedule: The Points Schedule drawing shall contain the same fields as the Points Schedule Contract Drawing with Contractor updated information. A Points Schedule shall be submitted for each HVAC system.

i. Riser diagram of building control network: The Riser Diagram of the Building Control Network shall show all network cabling, DDC Hardware, and Network Hardware including:

- (1) All DDC Hardware with room number and location within room.
- (2) DDC Hardware unique identifiers and common descriptive names.
- (3) All Network hardware with room number and location within room.
- (4) Network hardware unique identifiers.

(5) All cabling.

(6) Room number and location within room of all cabling termination points.

(7) Room number and location within room of all network interface jacks.

j. A single riser diagram shall be submitted for each building.

k. Control System Schematics: The control system schematics shall be in the same form as the control system schematic Contract Drawing with Contractor updated information. A control system schematic shall be submitted for each HVAC system.

l. Sequences of Operation: The HVAC control system sequences of operation shall be in the same format as the Contract Drawings and shall refer to the devices by their unique identifiers. No operational deviations from specified sequences will be permitted without prior written approval of the Government. Sequences of operation shall be submitted for each HVAC control system.

m. Controller, Motor Starter and Relay Wiring Diagram: The controller wiring diagrams shall be functional wiring diagrams which show the interconnection of conductors and cables to each controller and to the identified terminals of input and output devices, starters and package equipment. The wiring diagrams shall show necessary jumpers and ground connections. The wiring diagrams shall show the labels of all conductors. Sources of power required for control systems and for packaged equipment control systems shall be identified back to the panel board circuit breaker number, controller enclosures, magnetic starter, or packaged equipment control circuit. Each power supply and transformer not integral to a controller, starter, or packaged equipment shall be shown. The connected volt-ampere load and the power supply volt-ampere rating shall be shown. Wiring diagrams shall be submitted for each HVAC control system.

1.5.6 Draft As-Built Drawings

Update the Contractor Design Drawings with all as-built data and submit as specified.

1.5.7 Final As-Built Drawings

Update the Draft As-Built Drawings with all final as-built data and submit as specified.

1.6 DELIVERY, STORAGE, AND HANDLING

Store products with protection from the weather, humidity, and temperature variations, dirt and dust, and other contaminants, within the storage condition limits published by the equipment manufacturer.

1.7 PROJECT/SITE CONDITIONS

All products shall be rated for continuous operation under the following conditions:

- a. Pressure: Pressure conditions normally encountered in the installed location.
- b. Vibration: Vibration conditions normally encountered in the installed location.
- c. Temperature:
 - (1) Products installed indoors: Ambient temperatures in the range of 32 to 112 degrees F and temperature conditions outside this range normally encountered at the installed location.
 - (2) Products installed outdoors or in unconditioned indoor spaces: Ambient temperatures in the range of -35 to plus 151 degrees F and temperature conditions outside this range normally encountered at the installed location.
- d. Humidity: 10 to 95 percent relative humidity, noncondensing and humidity conditions outside this range normally encountered at the installed location.

1.8 PROJECT SEQUENCING

TABLE I. PROJECT SEQUENCING lists the submittals as specified in paragraph SUBMITTALS (denoted by an 'S' in the 'TYPE' column) and activities as specified in PART 3: EXECUTION (denoted by an 'E' in the 'TYPE' column).

- a. Sequencing for submittals: The sequencing specified for submittals is the deadline by which the submittal shall be initially submitted to the Government. Following submission there will be a Government review period as specified in Section 01 33 00 SUBMITTAL PROCEDURES. If the submittal is not accepted by the Government, revise the submittal and resubmit it to the Government within 14 days of notification that the submittal has been rejected. Upon resubmittal there shall be an additional Government review period. If the submittal is not accepted the process repeats until the submittal is accepted by the Government.
- b. Sequencing for Activities: The sequencing specified for activities indicates the earliest the activity may begin.
- c. Abbreviations: In TABLE I the abbreviation AAO is used for 'after approval of' and 'ACO' is used for 'after completion of'.

TABLE I. PROJECT SEQUENCING

ITEM #	TYPE	DESCRIPTION	SEQUENCING
			(START OF ACTIVITY or DEADLINE FOR SUBMITTAL)
1	S	Existing Conditions Report	
2	S	DDC Contractor Design Drawings	
3	S	Manufacturer's Catalog Data	
4	S	Network Bandwidth Usage Calculations	
5	S	Pre-construction QC Checklist	
6	E	Install Building Control System	AAO #1 thru #5
7	E	Start-Up and Start-Up Testing	ACO #6
8	S	Post-Construction QC Checklist	[_____] days ACO #7

TABLE I. PROJECT SEQUENCING

ITEM #	TYPE	DESCRIPTION	SEQUENCING
			(START OF ACTIVITY or DEADLINE FOR SUBMITTAL)
9	S	Programming Software	[_____] days ACO #7
10	S	XIF Files	[_____] days ACO #7
11	S	LNS Plug-ins	[_____] days ACO #7
12	S	Start-Up and Start-Up Testing Report	[_____] days ACO #7
13	S	Draft As-Built Drawings	[_____] days ACO #7
14	S	PVT Procedures (before schedule)	[_____] days start of #15 and AAO #12
15	E	PVT	AAO #13 and #14
16	S	PVT Report	[_____] days ACO #15
17	S	GPPC Application Programs	[_____] days AAO #16
18	S	LNS Database	[_____] days AAO #16
19	S	Final As-Built Drawings	[_____] days AAO #16
20	S	O&M Instructions	AAO #19
21	S	Training Documentation	AAO #12 and [_____] days before scheduled start of #22
22	E	Training	AAO #20 and #21
23	S	Closeout QC Checklist	ACO #22

1.9 SCHEDULING

1.9.1 System Mode

AHUs shall operate in Occupied, Warm-Up-Cool-Down, or Unoccupied modes as specified. VAV boxes, Fan Coils, and other terminal equipment shall operate in Occupied or Unoccupied modes as specified. Chillers, boilers, and other sources of heating/cooling for hydronic loads do not require scheduling; these systems receive requests for heating/cooling from their loads.

1.9.2 System Scheduler Requirements

The System Scheduler functionality shall reside in either a piece of DDC Hardware dedicated to this functionality or in the DDC Hardware controlling the system AHU. A single piece of DDC Hardware may contain multiple System Schedulers. A unique System Scheduler shall be provided for: each AHU including it's associated Terminal Units, and each stand-alone Terminal Unit (those not dependent upon AHU service), or group of stand-alone Terminal Units acting according to a common schedule. Each System Scheduler shall provide the following functionality:

- a. Scheduled Occupancy Input: Input shall support the following possible values: OC_STANDBY, OC_OCCUPIED and OC_UNOCCUPIED.
- b. Occupancy Override Input: Input shall support the following possible values: OC_STANDBY, OC_OCCUPIED, OC_UNOCCUPIED, and OC_NUL.
- c. Space Occupancy Inputs: For systems with multiple occupancy sensors, accept multiple inputs of network variable type SNVT_Occupancy. Input shall support the following possible values: OC_OCCUPIED, OC_UNOCCUPIED, and OC_NUL. For systems with a single occupancy sensor, accept a network variable input of type SNVT_Occupancy or a hardware binary input (BI) indicating the space

occupancy status as Occupied or Unoccupied.

d. Air Handler Occupancy Output: For a System Scheduler for a system containing an air handler, output one or more SNVTs indicating the desired occupancy status as one of the following possible values: Warm-Up-Cool-Down (when required by the AHU Sequence of Operation), Occupied and Unoccupied.

e. Default Schedule: Incorporate a 24-hour 7-day default schedule as shown on the drawings which may be activated and deactivated by the System Scheduler Logic.

f. Communication Determination: Determine the time elapsed between receipts of the scheduled occupancy input SNVT, and use this elapsed time to activate and deactivate the Default Schedule as specified. (This provides the capability for the system scheduler to use its Default Schedule if it loses communication with the UMCS).

1.9.3 System Scheduler Output Determination

a. Air Handler Occupancy Output: If more than 95 minutes have passed since the last receipt of the Scheduled Occupancy input, the Air Handler Occupancy Output shall be determined by the default schedule and the Space Occupancy Inputs. Otherwise, the output shall be determined as follows:

(1) If the Override Occupancy Input is not OC_NUL, the Air Handler Occupancy Output shall determined as follows:

(a) The output shall be Occupied when the Override Occupancy Input is OC_OCCUPIED.

(b) The output shall be Unoccupied when the Override Occupancy Input is OC_UNOCCUPIED.

(c) If the system Sequence Of Operation specifies Warm-Up-Cool-Down mode, the output shall be Warm-Up-Cool-Down when the Override Occupancy Input is OC_STANDBY.

(2) If the Override Occupancy Input is OC_NUL and the Schedule Occupancy input is OC_OCCUPIED, the Air Handler and Stand-Alone Terminal Unit Occupancy Output shall be OC_OCCUPIED.

(3) If the Override Occupancy Input is OC_NUL, the Schedule Occupancy input is not OC_OCCUPIED, and less than required number of Space Occupancy Inputs (as shown on the Occupancy Schedule Drawing) are OC_OCCUPIED (or the hardware BI is Unoccupied), the Air Handler Occupancy Output shall be determined by the Scheduled Occupancy Input

(a) The output shall be Occupied when the Scheduled Occupancy Input is OC_OCCUPIED.

(b) The output shall be Unoccupied when the Scheduled Occupancy Input is OC_UNOCCUPIED.

(If the system Sequence Of Operation specifies Warm-Up-Cool-Down mode the output shall be Warm-Up-Cool-Down when the Scheduled Occupancy Input is OC_STANDBY.

(4) If the Override Occupancy Input is OC_NUL and at least the required number (as shown on the Occupancy Schedule Drawing) of Space Occupancy Inputs are OC_OCCUPIED (or the hardware BI is Occupied), the Air Handler Occupancy Output shall be Occupied.

1.9.4 Air Handler System Scheduling

a. The AHU Occupancy Output SNVT shall be bound from the System Scheduler to the DDC Hardware that executes the Occupancy Mode Determination part of the Air Handler Sequence of Operation

b. For Air Handlers using occupancy sensors, the occupancy sensor output SNVT (of type SNVT_Occupancy) shall be bound to a Space Occupancy Input of the System Scheduler.

c. AHU-Dependent Terminal Units with occupancy sensors shall have their Effective Occupancy SNVT (of type SNVT_Occupancy) bound to a Space Occupancy Input of the System Scheduler.

1.9.5 Stand-Alone Terminal Unit Scheduling

The Terminal Unit Occupancy Output shall be bound from the System Scheduler to the DDC Hardware that executes the Occupancy Mode Determination part of the Terminal Unit Sequence of Operation.

1.10 MAINTENANCE

1.10.1 General

The HVAC control System Operation and Maintenance (O&m) Instructions shall include:

a. "Manufacturer Data Package 3" as specified in Section 01 78 23 OPERATION AND MAINTENANCE DATA for each piece of control equipment.

b. "Manufacturer Data Package 4" as described in Section 01 78 23 for all air compressors.

c. HVAC control system sequences of operation formatted as specified.

d. Procedures for the HVAC system start-up, operation and shut-down including the manufacturer's supplied procedures for each piece of equipment, and procedures for the overall HVAC system.

e. As-built HVAC control system detail drawings formatted as specified.

f. Printouts of configuration settings for all devices.

g. Routine maintenance checklist. The routine maintenance checklist shall be arranged in a columnar format. The first column shall list all installed devices, the second column shall state the maintenance activity or state no maintenance required, the third column shall state the frequency of the maintenance activity, and the fourth column for

additional comments or reference.

h. Qualified service organization list.

i. Start-Up and Start-Up Testing Report.

j. Performance Verification Test (PVT) Procedures and Report.

1.10.2 Maintenance Service

Provide services, materials and equipment as necessary to maintain the entire system in an operational state as specified for a period of one year after successful completion and acceptance of the Performance Verification Test. Minimize impacts on facility operations.

1.10.2.1 Description of Work

The adjustment and repair of the system shall include the manufacturer's required sensor and actuator (including transducer) calibration, span and range adjustment.

1.10.2.2 Personnel

Use qualified service personnel to accomplish work promptly and satisfactorily. Advise the Government in writing of the name of the designated service representative, and of any changes in personnel.

1.10.2.3 Scheduled Inspections

Perform two inspections at six-month intervals, and all work required shall be performed. Inspections shall be scheduled in July and January. These inspections shall include:

a. Visual checks and operational tests of equipment.

b. Fan checks and filter changes for control system equipment.

c. Clean control system equipment including interior and exterior surfaces.

d. Check and calibrate each field device. Check and calibrate 50 percent of the total analog inputs and outputs during the first inspection. Check and calibrate the remaining 50 percent of the analog inputs and outputs during the second major inspection. Certify analog test instrumentation accuracy to be twice the specified accuracy of the device being calibrated. Randomly check at least 25 percent of all digital inputs and outputs for proper operation during the first inspection. Randomly check at least 25 percent of the remaining digital inputs and outputs during the second inspection.

e. Run system software diagnostics and correct diagnosed problems.

f. Resolve any previous outstanding problems.

1.10.2.4 Scheduled Work

This work shall be performed during regular working hours, Monday through

Friday, excluding Federal holidays.

1.10.2.5 Emergency Service

The Government will initiate service calls when the system is not functioning properly. Qualified personnel shall be available to provide service to the system. A telephone number where the service supervisor can be reached at all times shall be provided. Service personnel shall be at the site within 24 hours after receiving a request for service. The control system shall be restored to proper operating condition as required in accordance with Section 01 78 00 CLOSEOUT SUBMITTALS.

1.10.2.6 Operation

Scheduled adjustments and repairs shall include verification of the control system operation as demonstrated by the applicable tests of the performance verification test.

1.10.2.7 Records and Logs

Keep dated records and logs of each task, with cumulative records for each major component, and for the complete system chronologically. A continuous log shall be maintained for all devices. The log shall contain initial analog span and zero calibration values and digital points. Complete logs shall be kept and shall be available for inspection onsite, demonstrating that planned and systematic adjustments and repairs have been accomplished for the control system.

1.10.2.8 Work Requests

Record each service call request as received and include its location, date and time the call was received, nature of trouble, names of the service personnel assigned to the task, instructions describing what has to be done, the amount and nature of the materials to be used, the time and date work started, and the time and date of completion. Submit a record of the work performed within 5 days after work is accomplished.

PART 2 PRODUCTS

2.1 MATERIALS AND EQUIPMENT

Provide materials and equipment which are standard products of Siemens Apogee(R) system. Submit manufacturer's catalog data sheets documenting compliance with product specifications as specified for each product installed under this specification.

2.2 ENCLOSURES AND WEATHERSHIELDS

2.2.1 Enclosures

Enclosures shall meet the following minimum requirements:

- a. Outdoors: Enclosures located outdoors shall meet NEMA 250 Type 3 or Type 4 requirements.
- b. Mechanical and Electrical Rooms: Enclosures located in mechanical or electrical rooms shall meet NEMA 250 Type 2 requirements.

c. Other Locations: Enclosures in other locations including but not limited to occupied spaces, above ceilings, and plenum returns shall meet NEMA 250 Type 1 requirements.

d. Enclosures supplied as an integral (pre-packaged) part of another product are acceptable.

2.2.2 Weathershields

Weathershields for sensors located outdoors shall prevent the sun from directly striking the sensor. Provide the weathershield with adequate ventilation so that the sensing element responds to the ambient conditions of the surroundings. The weathershield shall prevent rain from directly striking or dripping onto the sensor. Install weathershields near outside air intake ducts such that normal outside air flow does not cause rainwater to strike the sensor. Provide weathershields constructed of galvanized steel painted white, unpainted aluminum, aluminum painted white, or white PVC.

2.3 TUBING

2.3.1 Copper

Copper tubing shall conform to ASTM B 88 and ASTM B 88M

2.3.2 Stainless Steel

Stainless steel tubing shall conform to ASTM A 269

2.3.3 Plastic

Plastic tubing shall have the burning characteristics of linear low-density polyethylene tubing, shall be self-extinguishing when tested in accordance with ASTM D 635, shall have UL 94 V-2 flammability classification or better, and shall withstand stress cracking when tested in accordance with ASTM D 1693. Plastic-tubing bundles shall be provided with Mylar barrier and flame-retardant polyethylene jacket.

2.4 NETWORK HARDWARE

2.4.1 CEA-709.1B Network Hardware

2.4.1.1 CEA-709.1B Routers

CEA-709.1B Routers (including routers configured as repeaters) shall meet the requirements of CEA-709.1B and shall provide connection between two or more CEA-709.3 TP/FT-10 channels.

2.4.1.2 CEA-709.3 Repeater

CEA-709.3 Repeater shall be physical layer repeaters in accordance with CEA-709.3.

2.4.2 Gateways

Gateways shall perform bi-directional protocol translation from one non-CEA-709.1B protocol to CEA-709.1B. Gateways shall incorporate exactly two

network connections: one shall be for connection to a TP/FT-10 network in accordance with CEA-709.3 and the second shall be as required to communicate with the non-CEA-709.1B network.

2.5 WIRE AND CABLE

All wire and cable shall meet the requirements of NFPA 70 and NFPA 90A in addition to the requirements of this specification.

2.5.1 Terminal Blocks

Terminal blocks which are not integral to other equipment shall be insulated, modular, feed-through, clamp style with recessed captive screw-type clamping mechanism, shall be suitable for rail mounting, and shall have end plates and partition plates for separation or shall have enclosed sides.

2.5.2 Control Wiring for Binary Signals

Control wiring for binary signals shall be 18 AWG copper and shall be rated for 300-volt service.

2.5.3 Wiring for 120-Volt Circuits

Wiring for 120-volt circuits shall be 18 AWG or thicker stranded copper and shall be rated for 600-volt service.

2.5.4 Control Wiring for Analog Signals

Control Wiring for Analog Signals shall be 18 AWG, copper, single- or multiple-twisted, minimum 2 inch lay of twist, 100 percent shielded pairs, and shall have a 300-volt insulation. Each pair shall have a 20 AWG tinned-copper drain wire and individual overall pair insulation. Cables shall have an overall aluminum-polyester or tinned-copper cable-shield tape, overall 20 AWG tinned-copper cable drain wire, and overall cable insulation.

2.5.5 Transformers

Transformers shall be UL 1585 approved. Transformers shall be sized so that the connected load is no greater than 80 percent of the transformer rated capacity.

2.6 AUTOMATIC CONTROL VALVES

Valves shall have stainless-steel stems and stuffing boxes with extended necks to clear the piping insulation. Valve bodies shall meet ASME B16.34 or ASME B16.15 pressure and temperature class ratings based on the design operating temperature and 150 percent of the system design operating pressure. Unless otherwise specified or shown, valve leakage shall meet FCI 70-2 Class IV leakage rating (0.01 percent of valve Kv). Unless otherwise specified or shown, valves shall have globe-style bodies. Unless otherwise specified:

- a. bodies for valves 1.5 inches and smaller shall be brass or bronze, with threaded or union ends

- b. bodies for 2 inch valves shall have threaded ends
- c. bodies for valves 2 to 3 inches shall be of brass, bronze or iron.
- d. bodies for valves 2.5 inches and larger shall be provided with flanged-end connections.
- e. for modulating applications, valve Kv (Cv) shall be within 100 to 125 percent of the Kv (Cv) shown.
- f. for two position applications (where the two positions are full open and full closed) the Kv (Cv) shall be the largest available for the valve size.
- g. valve and actuator combination shall be normally open or normally closed as shown.

2.6.1 Ball Valves

Balls shall be stainless steel or nickel plated brass. Valves shall have blow-out proof stems. In steam and high temperature hot water applications, the valve-to-actuator linkage shall provide a thermal break.

2.6.2 Butterfly

Butterfly valves shall be threaded lug type suitable for dead-end service and modulation to the fully-closed position, with carbon-steel bodies and non-corrosive discs, stainless steel shafts supported by bearings, and EPDM seats suitable for temperatures from -20 to plus 250 degrees F. The rated Kv (Cv) for butterfly valves shall be the value Kv (Cv) at 70 percent (60 degrees) open position. Valve leakage shall meet FCI 70-2 Class VI leakage rating.

2.6.3 Two-Way

Two-way modulating valves used for liquids shall have an equal-percentage characteristic. Two-way modulating valves used for steam shall have a linear characteristic.

2.6.4 Three-Way

Three-way modulating valves shall provide equal percentage flow control with constant total flow throughout full plug travel.

2.6.5 Chilled-Water and Glycol

Valve internal trim shall be Type 316 stainless steel. Valves 4 inches and larger shall be butterfly valves.

2.7 DAMPERS

2.7.1 Damper Assembly

A single damper section shall have blades no longer than 48 inch and shall be no higher than 72 inch. Maximum damper blade width shall be 8 inch. Larger sizes shall be made from a combination of sections. Dampers shall be steel, or other materials where shown. Flat blades shall be made rigid

by folding the edges. Blade-operating linkages shall be within the frame so that blade-connecting devices within the same damper section shall not be located directly in the air stream. Damper axles shall be 1/2 inch minimum, plated steel rods supported in the damper frame by stainless steel or bronze bearings. Blades mounted vertically shall be supported by thrust bearings. Pressure drop through dampers shall not exceed 0.04 inches water gauge at 1,000 ft/min in the wide-open position. Frames shall not be less than 2 inch in width. Dampers shall be tested in accordance with AMCA 500-D.

2.7.2 Operating Linkages

Operating links external to dampers, such as crank arms, connecting rods, and line shafting for transmitting motion from damper actuators to dampers, shall withstand a load equal to at least 300 percent of the maximum required damper-operating force. Rod lengths shall be adjustable. Links shall be brass, bronze, zinc-coated steel, or stainless steel. Working parts of joints and clevises shall be brass, bronze, or stainless steel. Adjustments of crank arms shall control the open and closed positions of dampers.

2.7.3 Damper Types

2.7.3.1 Flow Control Dampers

Outside air, return air, relief air, exhaust, face and bypass dampers shall be provided where shown and shall be parallel-blade or opposed blade type as shown on the Damper Schedule. Blades shall have interlocking edges and shall be provided with compressible seals at points of contact. The channel frames of the dampers shall be provided with jamb seals to minimize air leakage. Unless otherwise shown, dampers shall be AMCA 500-D Class 2 and shall not leak in excess of 20 cfm per square foot at 4 inches water gauge static pressure when closed. Outside air damper seals shall be suitable for an operating temperature range of -40 to plus 167 degrees F. Dampers shall be rated at not less than 2000 ft/min air velocity.

2.7.3.2 Mechanical Rooms and Other Utility Space Ventilation Dampers

Utility space ventilation dampers shall be as shown. Unless otherwise shown, dampers shall be AMCA 500-D class 4 and shall not leak in excess of 80 cfm per square foot at 4 inches water gauge static pressure when closed. Dampers shall be rated at not less than 1500 ft/min air velocity.

2.8 SENSORS AND INSTRUMENTATION

Unless otherwise specified, sensors and instrumentation shall incorporate an integral transmitter or be provided with a transmitter co-located with the sensor. Sensors and instrumentation, including their transmitters, shall meet the specified accuracy and drift requirements at the input of the connected DDC Hardware's analog-to-digital conversion. Sensors and instrumentation, including their transmitters, shall meet or exceed the specified range.

2.8.1 Transmitters

The transmitter shall match the characteristics of the sensor. Transmitters providing analog values shall produce a linear 4-20 mAdc, 0-10 Vdc or SNVT output corresponding to the required operating range and shall

have zero and span adjustment. Transmitters providing binary values shall have dry contacts or SNVT output. Transmitters with SNVT output are Application Specific Controllers (ASCs) and shall meet all ASC requirements. (note: ASCs are specified in paragraph DIRECT DIGITAL CONTROL (DDC) HARDWARE)

2.8.2 Temperature Sensors

2.8.2.1 Sensor Ranges and Accuracy

Temperature sensors may be provided without transmitters. Temperature sensors, including transmitter if used, shall have minimum operating ranges, minimum accuracy and maximum drift as specified below for the application:

a. Conditioned Space Temperature

- (1) Operating Range: 50 to 86 degrees F.
- (2) Accuracy: +/- 1 degree F over the operating range.
- (3) Drift: Maximum 1 degree F per year.

b. Unconditioned Space Temperature

- (1) Operating Range: 20 to 150 degrees F.
- (2) Accuracy: +/- 1 degree F over the range of 30 to 131 degrees F and +/- 4 degrees F over the rest of the operating range.
- (3) Drift: Maximum 1 degree F per year.

c. Duct Temperature

- (1) Operating Range: 40 to 140 degrees F.
- (2) Accuracy: +/- 2 degrees F.
- (3) Drift: Maximum 2 degrees F per year.

d. Outside Air Temperature

- (1) Operating Range: 0 to 120 degrees F.
- (2) Accuracy:
 - (a) +/- 2 degrees F over the range of -30 to plus 130 degrees F.
 - (b) +/- 1 degree F over the range of 30 to 100 degrees F.
- (3) Drift: Maximum 1 degree F per year.

e. Chilled Water

- (1) Operating Range: 30 to 100 degrees F.

(2) Accuracy: +/- 0.8 degrees F over the range of 35 to 65 degrees F and +/- 2 degrees F over the rest of the operating range.

(3) Drift: Maximum 0.8 degrees F per year.

2.8.2.2 Point Temperature Sensors

Point Sensors shall be encapsulated in epoxy, series 300 stainless steel, anodized aluminum, or copper.

2.8.2.3 Averaging Temperature Sensors

Averaging sensors shall be a continuous element with a minimum length equal to 1 foot/square foot of duct cross-sectional area at the installed location. The sensing element shall have a bendable copper sheath.

2.8.2.4 Thermowells

Thermowells shall be Series 300 stainless steel with threaded brass plug and chain, 2 inch lagging neck and extension type well. Inside diameter and insertion length shall be as required for the application.

2.8.3 Relative Humidity Sensor

Relative humidity sensors shall use bulk polymer resistive or thin film capacitive type non-saturating sensing elements capable of withstanding a saturated condition without permanently affecting calibration or sustaining damage. The sensors shall include removable protective membrane filters. Where required for exterior installation, sensors shall be capable of surviving below freezing temperatures and direct contact with moisture without affecting sensor calibration. When used indoors, the sensor shall be capable of being exposed to a condensing air stream (100 percent RH) with no adverse effect to the sensor's calibration or other harm to the instrument. The sensor shall be of the wall-mounted or duct-mounted type, as required by the application, and shall be provided with any required accessories. Sensors used in duct high-limit applications shall have a bulk polymer resistive sensing element. Duct-mounted sensors shall be provided with a duct probe designed to protect the sensing element from dust accumulation and mechanical damage. Relative humidity (RH) sensors shall measure relative humidity over a range of 0 to 100 percent with an accuracy of +/- 3 percent. RH sensors shall function over a temperature range of 25 to 130 degrees F and shall not drift more than 2 percent per year.

2.8.4 Carbon Dioxide (CO2) Sensors

Carbon dioxide (CO2) sensors shall measure CO2 concentrations between 0 to 2000 parts per million (ppm) using non-dispersive infrared (NDIR) technology with an accuracy of +/- 75 ppm and a maximum response time of 1 minute. The sensor shall be rated for operation at ambient air temperatures within the range of 32 to 122 degrees F and relative humidity within the range of 0 to 95 percent (non-condensing). The sensor shall have a maximum drift of 2 percent. The sensor chamber shall be manufactured with a non-corrosive material (such as gold-plating) that does not affect carbon dioxide concentration. Duct mounted sensors shall be provided with a duct probe designed to protect the sensing element from dust accumulation and mechanical damage.

2.8.5 Differential Pressure Instrumentation

2.8.5.1 Differential Pressure Sensors

Differential Pressure Sensor range shall be as shown or as required for the application. Pressure sensor ranges shall not exceed the high end range shown on the Points Schedule by more than 50 percent. The over pressure rating shall be a minimum of 150 percent of the highest design pressure of either input to the sensor. The accuracy shall be +/- 2 percent of full scale.

2.8.5.2 Differential Pressure Switch

The switch shall have a user-adjustable setpoint. The setpoint shall not be in the upper or lower quarters of the range. The over pressure rating shall be a minimum of 150 percent of the highest design pressure of either input to the sensor. The switch shall have two sets of contacts and each contact shall have a rating greater than it's connected load. Contacts shall open or close upon rise of pressure above the setpoint or drop of pressure below the setpoint as shown.

2.8.6 Flow Sensors

2.8.6.1 Annular Pitot Tube

Annular pitot tube shall be made of austenitic stainless steel with an accuracy of +/- 2 percent of full flow and a repeatability of +/- 0.5 percent of measured value. The unit shall have at least one static port and no less than four total head pressure ports with an averaging manifold.

2.8.6.2 Insertion Turbine Flowmeter

Insertion Turbine Flowmeter accuracy shall be +/- 1 percent of reading for a minimum turndown ratio of 1:1 through a maximum turndown ratio of 50:1. Repeatability shall be +/- 0.25 percent of reading. The meter flow sensing element shall operate over a range suitable for the installed location with a pressure loss limited to 1 percent of operating pressure at maximum flow rate. Design of the flowmeter probe assembly shall incorporate integral flow, temperature, and pressure sensors. The turbine rotor assembly shall be constructed of Series 300 stainless steel and use Teflon seals.

2.8.6.3 Vortex Shedding Flowmeter

Vortex Shedding Flowmeter accuracy shall be within +/- 0.8 percent of the actual flow. The flow meter body shall be made of austenitic stainless steel. The vortex shedding flowmeter body shall not require removal from the piping in order to replace the shedding sensor.

2.8.6.4 Positive Displacement Flow Meter

The flow meter shall be a direct reading, gerotor, nutating disk or vane type displacement device rated for liquid service as shown. A counter shall be mounted on top of the meter, and shall consist of a non-resettable mechanical totalizer for local reading, and a pulse transmitter for remote reading. The totalizer shall have a six digit register to indicate the volume passed through the meter in [liters] [gallons], and a sweep-hand dial to indicate down to 0.25 gallons. The pulse transmitter shall have a

hermetically sealed reed switch which is activated by magnets fixed on gears of the counter. The meter shall have a bronze body with threaded or flanged connections as required for the application. Output accuracy shall be +/- 2 percent of the flow range. The maximum pressure drop at full flow shall be 5 psig.

2.8.6.5 Flow Meters, Paddle Type

Sensor shall be non-magnetic, with forward curved impeller blades designed for water containing debris. Sensor accuracy shall be +/- 2 percent of rate of flow, minimum operating flow velocity shall be 1 foot per second. Sensor repeatability and linearity shall be +/- 1 percent. Materials which will be wetted shall be made from non-corrosive materials and shall not contaminate water. The sensor shall be rated for installation in pipes of 3 to 40 inch diameters. The transmitter housing shall be a NEMA 250 Type 4 enclosure.

2.8.6.6 Flow Switch

Flow switch shall have a repetitive accuracy of +/- 10 percent of actual flow setting. Switch actuation shall be adjustable over the operating flow range. The switch shall have Form C snap-action contacts, rated for the application. The flow switch shall have non flexible paddle with magnetically actuated contacts and be rated for service at a pressure greater than the installed conditions. Flow switch for use in sewage system shall be rated for use in corrosive environments encountered.

2.8.7 Occupancy Sensors

Occupancy sensors shall have occupancy-sensing sensitivity adjustment and an adjustable off-delay timer with a range encompassing 30 seconds to 15 minutes. Occupancy sensors shall be rated for operation in ambient air temperatures ranging from 50 to 104 degrees F or temperatures normally encountered in the installed location. Sensors integral to wall mount on-off light switches shall have an auto-off switch. Wall switch sensors shall be decorator style and shall fit behind a standard decorator type wall plate. All occupancy sensors, power packs, and slave packs shall be UL listed. In addition to any outputs required for lighting control, the occupancy sensor shall provide a contact output rated at 1A at 24 Vac or a SNVT output.

2.8.7.1 Passive Infrared (PIR) Occupancy Sensors

PIR occupancy sensors shall have a multi-level, multi-segmented viewing lens and a conical field of view with a viewing angle of 180 degrees and a detection of at least 20 feet unless otherwise shown or specified. PIR Sensors shall provide field-adjustable background light-level adjustment with an adjustment range suitable to the light level in the sensed area, room or space. PIR sensors shall be immune to false triggering from RFI and EMI.

2.8.7.2 Ultrasonic Occupancy Sensors

Ultrasonic sensors shall operate at a minimum frequency 32 kHz and shall be designed to not interfere with hearing aids.

2.8.7.3 Dual-Technology Occupancy Sensor (PIR and Ultrasonic)

Dual-Technology Occupancy Sensors shall meet the requirements of both PIR and Ultrasonic Occupancy Sensors.

2.8.8 Temperature Switch

2.8.8.1 Duct Mount Temperature Low Limit Safety Switch (Freezestat)

Duct mount temperature low limit switches (Freezestats) shall be manual reset, low temperature safety switches with a minimum element length of 1 foot/square-foot of coverage which shall respond to the coldest 18 inch segment with an accuracy of +/- 3.6 degrees F. The switch shall have a field-adjustable setpoint with a range of at least 30 to 50 degrees F. The switch shall have two sets of contacts, and each contact shall have a rating greater than its connected load. Contacts shall open or close upon drop of temperature below setpoint as shown and shall remain in this state until reset.

2.8.8.2 Pipe Mount Temperature Limit Switch (Aquistat)

Pipe mount temperature limit switches (aquastats) shall have a field adjustable setpoint between 60 and 90 degrees F, an accuracy of +/- 3.6 degrees F and a 10 degrees F fixed deadband. The switch shall have two sets of contacts, and each contact shall have a rating greater than its connected load. Contacts shall open or close upon change of temperature above or below setpoint as shown.

2.8.9 Damper End Switches

Each end switch shall be a hermetically sealed switch with a trip lever and over-travel mechanism. The switch enclosure shall be suitable for mounting on the duct exterior and shall permit setting the position of the trip lever that actuates the switch. The trip lever shall be aligned with the damper blade.

2.9 INDICATING DEVICES

All indicating devices shall display readings in English (inch-pound) units.

2.9.1 Thermometers

Thermometers shall not contain mercury. Unless otherwise specified, thermometers shall have an accuracy of +/- 3 percent of scale range. Thermometers shall have a range suitable for the application with an upper end of the range not to exceed 150 percent of the design upper limit.

2.9.1.1 Piping System Thermometers

Piping system thermometers shall have brass, malleable iron or aluminum alloy case and frame, clear protective face, permanently stabilized glass tube with indicating-fluid column, white face, black numbers, and a 9 inch scale. Piping system thermometers shall have an accuracy of +/- 1 percent of scale range. Thermometers for piping systems shall have rigid stems with straight, angular, or inclined pattern. Thermometer stems shall have expansion heads as required to prevent breakage at extreme temperatures. On rigid-stem thermometers, the space between bulb and stem shall be filled with a heat-transfer medium.

2.9.1.2 Air-Duct Thermometers

Air-duct thermometers shall have perforated stem guards and 45-degree adjustable duct flanges with locking mechanism.

2.9.2 Pressure Gauges

Gauges shall be suitable for field or panel mounting as required, shall have black legend on white background, and shall have a pointer traveling through a 270-degree arc. Gauge range shall be suitable for the application with an upper end of the range not to exceed 150 percent of the design upper limit. Accuracy shall be +/- 3 percent of scale range. Gauges shall meet requirements of ASME B40.100.

2.9.3 Low Differential Pressure Gauges

Gauges for low differential pressure measurements shall be a minimum of 3.5 inch (nominal) size with two sets of pressure taps, and shall have a diaphragm-actuated pointer, white dial with black figures, and pointer zero adjustment. Gauge range shall be suitable for the application with an upper end of the range not to exceed 150 percent of the design upper limit. Accuracy shall be plus or minus two percent of scale range.

2.10 OUTPUT DEVICES

Output Devices with SNVT input are ASCs and shall meet all ASC requirements in addition to the output device requirements. (Note: ASCs are specified in paragraph DIRECT DIGITAL CONTROL (DDC) HARDWARE.)

2.10.1 Actuators

Actuators shall be electric (electronic). All actuators shall be normally open (NO), normally closed (NC) or fail-in-last-position (FILP) as shown. Normally open and normally closed actuators shall be of mechanical spring return type. Electric actuators shall have an electronic cut off or other means to provide burnout protection if stalled. Actuators shall have a visible position indicator. [Electric actuators shall provide position feedback to the controller as shown.] Actuators shall smoothly open or close the devices to which they are applied. Pneumatic actuators shall have a full stroke response time matching the connected Electric to Pneumatic Transducer (EP). Electric actuators shall have a full stroke response time in both directions of 90 seconds or less at rated load. Electric actuators shall be of the foot-mounted type with an oil-immersed gear train or the direct-coupled type. Where multiple electric actuators operate from a common signal, the actuators shall provide an output signal identical to its input signal to the additional devices. [Pneumatic actuators shall be rated for 25 psi operating pressure except for high-pressure cylinder-type actuators.]

2.10.1.1 Valve Actuators

Valve actuators shall provide shutoff pressures and torques as shown on the Valve Schedule.

2.10.1.2 Damper Actuators

Damper actuators shall provide the torque necessary in accordance with

damper manufacturer's instructions to modulate the dampers smoothly over its full range of operation and torque shall be at least 6 inch-pounds/1 square foot of damper area for opposed blade dampers and 9 inch-pounds/1 square foot of damper area for parallel blade dampers.

2.10.1.3 Positive Positioners

Positive positioners shall be a pneumatic relay with a mechanical position feedback mechanism and an adjustable operating range and starting point.

2.10.2 Relays

Control relay contacts shall have utilization category and ratings selected for the application, with a minimum of two sets of contacts enclosed in a dust proof enclosure. Each set of contacts shall incorporate a normally open (NO), normally closed (NC) and common contact. Relays shall be rated for a minimum life of one million operations. Operating time shall be 20 milliseconds or less. Relays shall be equipped with coil transient suppression devices to limit transients to 150 percent of rated coil voltage.

2.11 USER INPUT DEVICES

User Input Devices, including potentiometers, switches and momentary contact push-buttons with SNVT output are Application Specific Controllers (ASCs) and shall meet all ASC requirements. (Note: ASCs are specified in paragraph DIRECT DIGITAL CONTROL (DDC) HARDWARE). Potentiometers shall be of the thumb wheel or sliding bar type. Momentary Contact Push-Buttons may include an adjustable timer for their output. User input devices shall be labeled for their function.

2.12 MULTIFUNCTION DEVICES

Multifunction devices are products which combine the functions of multiple sensor, user input or output devices into a single product. Unless otherwise specified, the multifunction device shall meet all requirements of each component device. Where the requirements for the component devices conflict, the multifunction device shall meet the most stringent of the requirements.

2.12.1 Current Sensing Relay Command Switch

The Current Sensing Relay portion shall meet all requirements of the Current Sensing Relay input device. The Command Switch portion shall meet all requirements of the Relay output device except that it shall have at least one normally-open (NO) contact.

2.12.2 Thermostats

Thermostats shall be multifunction devices incorporating a temperature sensor and a temperature indicating device. Thermostats shall not contain mercury (Hg). In addition, the thermostat shall have the following as specified and shown:

- a. A User Input Device which shall adjust a temperature setpoint output.

- b. A User Input Momentary Contact Button and an output indicating zone occupancy.
- c. A three position User Input Switch labeled to indicate heating, cooling and off positions ('HEAT-COOL-OFF' switch) and providing corresponding outputs.
- d. A two position User Input Switch labeled with 'AUTO' and 'ON' positions and providing corresponding outputs.
- e. A multi-position User Input Switch with 'OFF' and at least two fan speed positions and providing corresponding outputs.

2.13 DIRECT DIGITAL CONTROL (DDC) HARDWARE

2.13.1 General Requirements

All DDC Hardware shall be the standard product as manufactured, serviced, and sold by Siemens APOGEE(R).

2.13.2 Hardware Input-Output (I/O) Functions

DDC Hardware incorporating hardware input-output (I/O) functions shall meet the following requirements:

- a. Analog Inputs: DDC Hardware analog inputs (AIs) shall perform analog to digital (A-to-D) conversion with a minimum resolution of 8 bits plus sign or better as needed to meet the accuracy requirements specified in paragraph INPUT MEASUREMENT ACCURACY. Signal conditioning including transient rejection shall be provided for each analog input. Analog inputs shall be capable of being individually calibrated for zero and span. The AI shall incorporate common mode noise rejection of at least 50 dB from 0 to 100 Hz for differential inputs, and normal mode noise rejection of at least 20 dB at 60 Hz from a source impedance of 10,000 ohms.
- b. Analog Outputs: DDC Hardware analog outputs (AOs) shall perform digital to analog (D-to-A) conversion with a minimum resolution of 8 bits plus sign, and output a signal with a range of 4-20 mA_{dc} or 0-10 V_{dc}. Analog outputs shall be capable of being individually calibrated for zero and span.
- c. Binary Inputs: DDC Hardware binary inputs (BIs) shall accept contact closures and shall ignore transients of less than 5 milli-second duration. Isolation and protection against an applied steady-state voltage up to 180 Vac peak shall be provided.
- d. Binary Outputs: DDC Hardware binary outputs (BOs) shall provide relay contact closures or triac outputs for momentary and maintained operation of output devices.

(1) Relay Contact Closures: Closures shall have a minimum duration of 0.1 second. Relays shall provide at least 180V of isolation. Electromagnetic interference suppression shall be provided on all output lines to limit transients to non-damaging levels. Minimum contact rating shall be one ampere at 24 Vac.

(2) Triac outputs: Triac outputs shall provide at least 180 V of isolation.

e. Pulse Accumulator: DDC Hardware pulse accumulators shall have the same characteristics as the BI. In addition, a buffer shall be provided to totalize pulses. The pulse accumulator shall accept rates of at least 20 pulses per second. The totalized value shall be reset to zero upon operator's command.

2.13.3 Application Specific Controller (ASC)

Application Specific Controllers (ASCs) have a fixed factory-installed application program (i.e. ProgramID) with configurable settings. ASCs shall meet the following requirements in addition to the General DDC Hardware and DDC Hardware Input-Output (I/O) Function requirements:

a. ASCs shall be LonMark Certified.

b. Unless otherwise approved, all necessary Configuration Parameters and network configuration inputs (*ncis*) for the sequence and application in which the ASC is used shall be fully configurable through an LNS plug-in. This plug-in shall be submitted as specified for each type of ASC (manufacturer and model). (Note: configuration accomplished via hardware settings does not require configuration via plug-in)

c. Local Display Panel (LDP): The Local Display Panel shall be an Application Specific Controller (ASC) with a display and navigation buttons. It shall provide display and adjustment of SNVT inputs and SNVT outputs as shown.

2.13.4 General Purpose Programmable Controller (GPPC)

A General Purpose Programmable Controller (GPPC) is not installed with a fixed factory-installed application program. GPPCs shall meet the following requirements in addition to the general DDC Hardware requirements and Hardware Input-Output (I/O) Function:

a. The programmed GPPC shall conform to the LonMark Interoperability Guide.

b. All programming software required to program the GPPC shall be delivered to and licensed to the project site as specified.

c. Copies of the installed GPPC application programs as source code compatible with the supplied programming software shall be submitted as specified. The submitted GPPC application program shall be the complete application necessary for the GPPC to function as installed and be sufficient to allow replacement of the installed controller with a GPPC of the same type.

PART 3 EXECUTION

3.1 EXAMINATION

After becoming familiar with all details of the work, verify all dimensions in the field, and advise the Contracting Officer of any discrepancy before

performing any work.

3.2 CONTROL SYSTEM INSTALLATION

3.2.1 General Installation Requirements

3.2.1.1 HVAC Control System

The HVAC control system shall be completely installed, tested and ready for operation. Provide dielectric isolation where dissimilar metals are used for connection and support. Penetrations through and mounting holes in the building exterior shall be made watertight. The HVAC control system installation shall provide clearance for control system maintenance by maintaining access space required to calibrate, remove, repair, or replace control system devices. The control system installation shall not interfere with the clearance requirements for mechanical and electrical system maintenance.

3.2.1.2 Device Mounting Criteria

Install all devices in accordance with manufacturer's recommendations and as specified and shown. Provide control devices, to be installed in piping and ductwork, with required gaskets, flanges, thermal compounds, insulation, piping, fittings, and manual valves for shutoff, equalization, purging, and calibration. Strap-on temperature sensing elements shall not be used except as specified. Install spare thermowells adjacent to each thermowell containing a sensor and as shown. Devices located outdoors shall have a weathershield.

3.2.1.3 Labels and Tags

Key labels and tags to the unique identifiers shown on the As-Built drawings. Label all enclosures and DDC hardware. All sensors and actuators in mechanical rooms shall be tagged. Tag airflow measurement arrays to show flow rate range for signal output range, duct size, and pitot tube AFMA flow coefficient. Duct static pressure taps shall be tagged at the location of the pressure tap. Tags shall be plastic or metal and shall be mechanically attached directly to each device or attached by a metal chain or wire. Labels, outside of protective enclosures, shall be engraved plastic and mechanically attached to the enclosure or DDC Hardware. Labels inside protective enclosures may attached using adhesive, but shall not be hand written.

3.2.2 DDC Hardware

Install DDC hardware in an enclosure. Except for DDC hardware used to control Terminal Units, where multiple pieces of DDC hardware are used to execute one sequence, all DDC hardware executing that sequence shall be on a common local control bus and isolated from all other DDC hardware via an CEA-709.1B router or CEA-709.3 repeater.

3.2.3 Network Interface Jack

A standard network interface jack shall be provided for each node on the control network. For terminal unit controllers with hardwired thermostats this network interface jack shall be located at the thermostat or within 10 ft of the controller. Locating the interface jack at the thermostat is

preferred. For all other nodes the network interface jack shall be located within 10 ft of the node. If the network interface jack is other than a 1/8 inch phone jack, provide an interface cable with a standard 1/8 inch phone jack on one end and a connector suitable for mating with installed network interface jack on the other. No more than one type of interface cable shall be required to access all network interface jacks. Furnish one interface cable.

3.2.4 Room Instrument Mounting

Room instruments, including but not limited to wall mounted thermostats and sensors located in occupied spaces shall be mounted 60 inches above the floor unless otherwise shown. Unless otherwise shown on the Thermostat Schedule:

- a. All other Thermostats shall be wall mounted.

3.2.5 Indication Devices Installed in Piping and Liquid Systems

Gauges in piping systems subject to pulsation shall have snubbers. Gauges for steam service shall have pigtail fittings with cock. Thermometers and temperature sensing elements installed in liquid systems shall be installed in thermowells.

3.2.6 Duct Smoke Detectors

Duct smoke detectors will be provided in supply and return air ducts in accordance with Section 28 31 64.00 10 FIRE DETECTION AND ALARM SYSTEM, ADDRESSABLE. Connect the DDC System to the auxiliary contacts provided on the Smoke Detector as required for system safeties and to provide alarms to the DDC system.

3.2.7 Occupancy Sensors

A sufficient quantity of occupancy sensors shall be provided to provide complete coverage of the area (room or space). Occupancy sensors shall be installed in accordance with NFPA 70 requirements and the manufacturer's instructions. Occupancy sensors shall not be located within 6 feet of HVAC outlets or heating ducts. PIR and dual-technology PIR/ultrasonic sensors shall not be installed where they can "see" beyond any doorway. Ultrasonic sensors shall not be installed in spaces containing ceiling fans. Sensors shall detect motion to within 2 feet of all room entrances and shall not trigger due to motion outside the room. The off-delay timer shall be set to 15 minutes unless otherwise shown. All sensor adjustments shall be made prior to beneficial occupancy, but after installation of furniture systems, shelving, partitions, etc. Each controlled area shall have one hundred percent coverage capable of detecting small hand-motion movements, accommodating all occupancy habits of single or multiple occupants at any location within the controlled room.

3.2.8 Temperature Limit Switch

A temperature limit switch (freezestat) shall be provided to sense the temperature at the location shown. A sufficient number of temperature limit switches (freezestats) shall be installed to provide complete coverage of the duct section. Manual reset limit switches shall be installed in approved, accessible locations where they can be reset

easily. The temperature limit switch (freezestat) sensing element shall be installed in a serpentine pattern and in accordance with the manufacturer's installation instructions.

3.2.9 Averaging Temperature Sensing Elements

Sensing elements shall be installed in a serpentine pattern located as shown.

3.2.10 Duct Static Pressure Sensors

The duct static pressure sensing tap shall be located at 75 percent to 100 percent of the distance between the first and last air terminal units. If the transmitter is wired in a homerun configuration to an AHU controller, the transmitter shall be located in the same enclosure as the air handling unit (AHU) controller(s) for the AHU serving the terminal units.

3.2.11 Relative Humidity Sensors

Relative humidity sensors in supply air ducts shall be installed at least 10 feet downstream of humidity injection elements.

3.2.12 Flowmeters

The minimum straight unobstructed piping for the flowmeter installation shall be at least 10 pipe diameters upstream and at least 5 pipe diameters downstream and in accordance with the manufacturer's installation instructions.

3.2.13 Dampers

3.2.13.1 Damper Actuators

Actuators shall not be mounted in the air stream. Multiple actuators shall not be connected to a common drive shaft. Actuators shall be installed so that their action shall seal the damper to the extent required to maintain leakage at or below the specified rate and shall move the blades smoothly.

3.2.13.2 Damper Installation

Dampers shall be installed straight and true, level in all planes, and square in all dimensions. Dampers shall move freely without undue stress due to twisting, racking (parallelogramming), bowing, or other installation error. Blades shall close completely and leakage shall not exceed that specified at the rated static pressure. Structural support shall be used for multi-section dampers. Acceptable methods include but are not limited to U-channel, angle iron, corner angles and bolts, bent galvanized steel stiffeners, sleeve attachments, braces, and building structure. Where multi-section dampers are installed in ducts or sleeves, they shall not sag due to lack of support. Jackshafts shall not be used to link more than three damper sections. Blade to blade linkages shall not be used. Outside and return air dampers shall be installed such that their blades direct their respective air streams towards each other to provide for maximum mixing of air streams.

3.2.14 Valves

3.2.14.1 Ball Valves

Two-position (open/closed) ball valves may only be used on chilled water, condenser water, hot water, or steam applications. Modulating ball valves may only be used for chilled water and condenser water applications (modulating ball valves shall not be used on steam or hot water applications). In modulating applications a characterizing equal-percentage disc shall be used.

3.2.14.2 Butterfly Valves

In two-way control applications, valve travel shall be limited to 70 percent (60 degrees) open position.

3.2.15 Local Gauges for Actuators

Pneumatic actuators shall have an accessible and visible pressure gauge installed in the tubing lines at the actuator as shown.

3.2.16 Wire and Cable

Wire and Cable shall be installed without splices between control devices and in accordance with NFPA 70 and NFPA 90A. Instrumentation grounding shall be installed in accordance with the device manufacturer's instructions and as necessary to prevent ground loops, noise, and surges from adversely affecting operation of the system. Ground rods installed by the Contractor shall be tested as specified in IEEE Std 142. Cables and conductor wires shall be tagged at both ends, with the identifier shown on the shop drawings. Electrical work shall be as specified in Section 26 20 00 INTERIOR DISTRIBUTION SYSTEM and as shown. Wiring external to enclosures shall be run [in raceways][as follows:

- a. Wiring other than low-voltage control and low-voltage network wiring shall be installed in raceways.
- b. Low-voltage control and low-voltage network wiring not in suspended ceilings over occupied spaces shall be installed in raceways, except that nonmetallic-sheathed cables or metallic-armored cables may be installed as permitted by NFPA 70.
- c. Low-voltage control and low-voltage network wiring in suspended ceilings over occupied spaces shall be installed in raceways, except:
 - (1) nonmetallic-sheathed cables or metallic-armored cables may be installed as permitted by NFPA 70.
 - (2) plenum rated cable in suspended ceilings over occupied spaces may be run without raceways.]

3.2.17 Copper Tubing

Copper tubing shall be hard-drawn in exposed areas and either hard-drawn or annealed in concealed areas. Only tool-made bends shall be used. Fittings for copper tubing shall be brass or copper solder joint type except at connections to apparatus, where fittings shall be brass compression type.

3.2.18 Plastic Tubing

Plastic tubing shall be run within covered raceways or conduit except when otherwise specified. Plastic tubing shall not be used for applications where the tubing could be subjected to a temperature exceeding 130 degrees F. Fittings for plastic tubing shall be for instrument service and shall be brass or acetal resin of the compression or barbed push-on type. Except in walls and exposed locations, plastic multitube instrument tubing bundle without conduit or raceway protection may be used where a number of air lines run to the same points, provided the multitube bundle is enclosed in a protective sheath, is run parallel to the building lines and is adequately supported as specified.

3.3 HVAC SYSTEMS OPERATION

3.3.1 Alarm Handling

Install and configure DDC Hardware to provide alarm handling functionality for critical alarms as specified and shown, either in a piece of DDC Hardware dedicated to this function or in DDC Hardware performing other functions. The DDC Hardware providing alarm handling functionality shall provide the following capabilities as required:

a. Dial to a pager: The node shall be able to dial a paging service and leave a numeric message.

[b. Dial to an e-mail server: The node shall be able to dial and connect to a remote server and send an e-mail via Simple Mail Transfer Protocol (SMTP).]

[c. Send e-mail over IP Network: The alarm handling node shall be capable of connecting to an IP network and sending e-mail via Simple Mail Transfer Protocol (SMTP).]

[d. Provide network access: The node shall be capable of receiving a connection via the modem to allow a remote computer access to the control network.]

3.3.2 Operation for Air Handling Units

3.3.2.1 Single Zone with Heating and DX Cooling Coils

Install DDC hardware to perform this Sequence of Operation and to provide SNVT inputs, outputs and alarms as specified and shown on the Points Schedule. Unless otherwise specified, all modulating control shall be proportional-integral (PI) control.

a. HAND-OFF-AUTO switch: Supply fan motor starter shall accept a Fire Alarm Panel (FAP) signal that takes precedence over all other starter inputs and switches and shall start the fan. The fan motor starter shall accept an occupant accessible emergency shutoff switch as shown. The supply fan motor starter shall have an H-O-A switch:

(1) HAND: With the H-O-A switch in HAND position, the supply fan shall start and run continuously, subject to Safeties.

(2) OFF: With the H-O-A switch in OFF position, the supply fan shall stop.

(3) AUTO: With the H-O-A switch in AUTO position, the supply fan shall run subject to the Supply Fan Start/Stop (SF-SS) command and Safeties.

b. Occupancy Modes: The system shall obtain its Occupancy Mode input from the System Scheduler as specified and shown. The system shall operate in one of the following modes: Occupied, Unoccupied.

3.3.2.2 Single Zone with Heating and Cooling Coils

Install DDC hardware to perform this Sequence of Operation and to provide SNVT inputs, outputs and alarms as specified and shown on the Points Schedule. Unless otherwise specified, all modulating control shall be proportional-integral (PI) control.

a. HAND-OFF-AUTO switch: Supply fan motor starter shall accept a Fire Alarm Panel (FAP) signal that takes precedence over all other starter inputs and switches and shall start the fan. The fan motor starter shall accept an occupant accessible emergency shutoff switch as shown. The supply fan motor starter shall have an H-O-A switch:

(1) HAND: With the H-O-A switch in HAND position, the supply fan shall start and run continuously, subject to Safeties.

(2) OFF: With the H-O-A switch in OFF position, the supply fan shall stop.

(3) AUTO: With the H-O-A switch in AUTO position, the supply fan shall run subject to the Supply Fan Start/Stop (SF-SS) command and Safeties.

b. Occupancy Modes: The system shall obtain its Occupancy Mode input from the System Scheduler as specified and shown. The system shall operate in one of the following modes: Occupied, Unoccupied[, or WarmUp/CoolDown].

c. System Enable and Loop Enable:

(1) Occupied Mode: The supply fan shall be enabled (SYS-ENA) and commanded to run (SF-SS) and all control loops shall be enabled.

(2) Unoccupied mode: While the building temperature (BLDG-T) is above setpoint (BLDG-T-LL-SP) all control loops shall be disabled and the supply fan shall not run. When BLDG-T drops below BLDG-T-LL-SP (with a 5 degrees F deadband) the supply fan shall be enabled (SYS-ENA) and commanded to run (SF-SS) and the Heating Coil Temperature Control loop shall be enabled. All other control loops shall be disabled.

[(3) Warm Up / Cool Down Mode: The supply fan shall be enabled (SYS-ENA) and commanded to run (SF-SS). The Minimum Outside Air Flow Control loop shall be disabled and all other control loops shall be enabled.]

d. Proofs and Safeties:

(1) The supply fan and all DDC Hardware control loops shall be

subject to Proofs and Safeties. Safeties shall be direct-hardwire interlocked to the fan starter circuit as shown. DDC Hardware shall monitor all proofs and safeties and failure of any proof or activation of any safety shall result in all control loops being disabled and the AHU fan being commanded off until reset.

(2) Proofs: Supply fan status (proof) (SF-S)

(3) Safeties:

(a) Heating coil discharge air temperature low limit (freezestat) (HTG-DA-T-LL)

(b) Supply air smoke (SA-SMK)

(c) Return air smoke (RA-SMK)

(4) DDC Hardware reset of all proofs and safeties shall be via a local binary push-button (RST-BUT) input to the DDC Hardware, via a remote command to the DDC Hardware via SNVT or both (where the Contractor provides both reset functions and the operator can use either one to perform the reset), as shown on the Points Schedule drawing.

e. Minimum Outside Air Flow Control: When this loop is enabled the DDC Hardware shall open the 2-position minimum outside air damper to introduce the minimum outside air flow quantity as shown. When this loop is disabled, the minimum outside air damper shall be closed.

f. Heating Coil Control: When this loop is enabled the DDC Hardware shall modulate the heating coil control valve in sequence with the bypass and supply dampers and the economizer dampers as shown to maintain zone temperature (ZN-T) at setpoint (ZN-T-SP) as shown. When this loop is disabled, the heating coil control valve shall be closed.

g. Cooling Coil Control: When this loop is enabled the DDC Hardware shall open the 2-position cooling coil control valve. When this loop is disabled, the 2-position cooling coil control valve shall be closed.

3.3.2.3 Single Zone with Humidity Control

Install DDC hardware to perform this Sequence of Operation and to provide SNVT inputs, outputs and alarms as specified and shown on the Points Schedule. Unless otherwise specified, all modulating control shall be proportional-integral (PI) control.

a. HAND-OFF-AUTO switch: Supply fan motor starter shall accept a Fire Alarm Panel (FAP) signal that takes precedence over all other starter inputs and switches and shall start the fan. The fan motor starter shall accept an occupant accessible emergency shutoff switch as shown. The supply fan motor starter shall have an H-O-A switch:

(1) HAND: With the H-O-A switch in HAND position, the supply fan shall start and run continuously, subject to Safeties.

(2) OFF: With the H-O-A switch in OFF position, the supply fan shall stop.

(3) AUTO: With the H-O-A switch in AUTO position, the supply fan shall run subject to the Supply Fan Start/Stop (SF-SS) command and Safeties.

b. Occupancy Modes: The system shall obtain its Occupancy Mode input from the System Scheduler as specified and shown. The system shall operate in one of the following modes: Occupied, Unoccupied[, or WarmUp/CoolDown].

c. System Enable and Loop Enable:

(1) Occupied Mode: The supply fan shall be enabled (SYS-ENA) and commanded to run (SF-SS) and all control loops shall be enabled.

(2) Unoccupied mode: While the building temperature (BLDG-T) is above setpoint (BLDG-T-LL-SP) all control loops shall be disabled and the supply fan shall not run. When BLDG-T drops below BLDG-T-LL-SP (with a 5 degrees F deadband) the supply fan shall be enabled (SYS-ENA) and commanded to run (SF-SS), the Preheat Coil Control loop and Reheat Coil Control loop shall be enabled and all other loops shall be disabled.

[(3) Warm Up / Cool Down Mode: The supply fan shall be enabled (SYS-ENA) and commanded to run (SF-SS). The Minimum Outside Air Flow Control loop shall be disabled and all other control loops shall be enabled.]

d. Proofs and Safeties

(1) The supply fan and all DDC Hardware control loops shall be subject to Proofs and Safeties. Safeties shall be direct-hardwire interlocked to the fan starter circuit as shown. DDC Hardware shall monitor all proofs and safeties and failure of any proof or activation of any safety shall result in all control loops being disabled and the AHU fan being commanded off until reset.

(2) Proofs: Supply fan status (proof) (SF-S)

(3) Safeties:

(a) Preheat coil discharge air temperature low limit (freezestat) (PH-DA-T-LL)

(b) Supply air smoke (SA-SMK)

(c) Return air smoke (RA-SMK)

(4) DDC Hardware reset of all proofs and safeties shall be via a local binary push-button (RST-BUT) input to the DDC Hardware, via a remote command to the DDC Hardware via SNVT or both (where the Contractor provides both reset functions and the operator can use either one to perform the reset), as shown on the Points Schedule drawing.

e. Minimum Outside Air Flow Control: When this loop is enabled the DDC Hardware shall open the 2-position minimum outside air damper to introduce the minimum outside air flow quantity as shown. When this loop is disabled, the minimum outside air damper shall be closed.

f. Preheat Coil Control Loop: When this loop is enabled the DDC Hardware shall modulate the preheat coil valve to maintain the preheat coil discharge air temperature (PH-T) at setpoint (PH-T-SP) as shown. When this loop is disabled, the preheat coil valve shall be closed.

g. Cooling-and-Dehumidification Coil Control: When this loop is enabled the DDC Hardware shall modulate the cooling and dehumidification valve to maintain either the zone temperature (ZN-T) at setpoint (ZN-T-SP) or zone relative humidity (ZN-RH) at setpoint (ZN-RH-SP), whichever calls for more chilled water flow. The valve shall be modulated in sequence with the reheat valve and humidification valve as shown to avoid simultaneous cooling and reheating, and simultaneous dehumidification and humidification. When this loop is disabled, the coil valve shall be closed.

h. Reheat Coil Control: When this loop is enabled the DDC Hardware shall modulate the reheat coil valve to maintain the zone temperature (ZN-T) at setpoint (ZN-T-SP) as shown. The valve shall be modulated in sequence with the cooling-and-dehumidification valve as shown to avoid simultaneous cooling and reheating. When this loop is disabled, the coil valve shall be closed.

3.3.2.3 Variable Air Volume System without Return Fan

Install DDC hardware to perform this Sequence of Operation and to provide SNVT inputs, outputs and alarms as specified and shown on the Points Schedule. Unless otherwise specified, all modulating control shall be proportional-integral (PI) control.

a. HAND-OFF-AUTO switches:

Supply fan variable frequency drive (VFD) unit shall accept a Fire Alarm Panel (FAP) signal that takes precedence over all other VFD inputs and switches and shall cause the VFD to run at 100 percent speed. The VFD shall accept an occupant accessible emergency shutoff switch as shown. The supply fan variable frequency drive (VFD) unit shall have an integral H-O-A switch:

(1) HAND: With the H-O-A switch in HAND position, the supply fan shall start and run continuously, subject to Safeties. Fan speed shall be under manual-operator control.

(2) OFF: With the H-O-A switch in OFF position, the supply fan shall stop.

(3) AUTO: With the H-O-A switch in AUTO position, the supply fan shall run subject to the Supply Fan Start/Stop Signal (SF-SS) and Safeties. Fan speed shall be under control of the DDC Hardware.

b. Occupancy Modes: The system shall obtain its Occupancy Mode input from the System Scheduler as specified and shown. The system shall operate in one of the following modes: Occupied, Unoccupied, or Warm Up/Cool Down.

c. Proofs and Safeties:

(1) The supply fan[, return fan,] and all DDC Hardware control loops shall be subject to Proofs and Safeties. Safeties shall be

direct-hardwire interlocked to the VFD as shown. DDC Hardware shall monitor all proofs and safeties and failure of any proof or activation of any safety shall result in all control loops being disabled and the AHU fan being commanded off until reset.

(2) Proofs:

(a) Supply fan status (SF-S)

(3) Safeties:

(a) Cooling coil discharge air temperature low limit (freezestat) (CLG-DA-T-LL)

(b) Supply air duct pressure high limit (SA-P-HL)

(c) Supply air smoke (SA-SMK)

(d) Return air smoke (RA-SMK)

(4) DDC Hardware reset of all proofs and safeties shall be via a local binary push-button (RST-BUT) input to the DDC Hardware, via a remote command to the DDC Hardware via SNVT or both (where the Contractor provides both reset functions and the operator can use either one to perform the reset), as shown on the Points Schedule drawing.

d. System Enable and Loop Enable

(1) Occupied mode: The supply fan shall be enabled (SYS-ENA) and commanded to run (SF-SS). All control loops shall be enabled. The Zone Temperature Control loops for VAV boxes serviced by the AHU shall also be enabled.

(2) Unoccupied mode: While the building temperature (BLDG-T) is above setpoint (BLDG-T-LL-SP) all control loops shall be disabled (except fan-powered VAV box Zone Temperature Control loops) and the supply fan shall not run. When BLDG-T drops below BLDG-T-LL-SP (with a 5 degrees F deadband) the supply fan shall be enabled (SYS-ENA) and commanded to run (SF-SS), the Supply Duct Static Pressure Control[, Return Fan Volume Control][, Preheat Control] loops shall be enabled. The Minimum Outside Air Flow Control, Mixed Air Temperature Control, and Cooling Coil Control loops shall be disabled.

[(3) Warm Up/Cool Down: The supply fan shall be enabled (SYS-ENA) and commanded to run (SF-SS). The Minimum Outside Air Flow Control loop shall be disabled and all other control loops shall be enabled. The Zone Temperature Control loops for VAV boxes serviced by the AHU shall also be enabled.]

e. Fan Capacity Control:

(1) Supply Duct Static Pressure Control. When this loop is enabled the DDC Hardware shall modulate the supply fan variable frequency drive unit to maintain the duct static pressure (SA-P) at setpoint (SA-P-SP) as shown, as measured by the duct static pressure tap and sensor as shown. When this loop is disabled, the DDC Hardware capacity modulation output to the VFD shall be zero

percent.

f. Minimum Outside Air Flow Control: When this loop is enabled the DDC Hardware shall modulate the minimum outside air damper to maintain the minimum OA volumetric flow (MINOA-F) at setpoint (MINOA-F-SP) as shown. When this loop is disabled, the minimum outside air damper shall be closed.

g. Cooling Coil Control: When this loop is enabled the DDC Hardware shall modulate the cooling coil valve to maintain the supply air temperature (SA-T) setpoint (SA-T-SP) as shown. When this loop is disabled, the cooling coil valve shall be closed.

h. Preheat Coil Control: When this loop is enabled the DDC Hardware shall energize the duct heater in the outside air duct to maintain the preheat coil discharge air temperature (PH-DA-T) at setpoint (PH-DA-T-SP) as shown.

3.3.3 Operation for Terminal Units

3.3.3.1 Zone Temperature Control - Cooling-Only VAV Box

Install DDC hardware to perform this Sequence of Operation and to provide SNVT inputs, outputs and alarms as specified and shown on the Points Schedule. Unless otherwise specified, all modulating control shall be proportional-integral (PI) control.

a. Occupancy Modes:

(1) Occupied: The VAV box DDC Hardware shall be in the Occupied Mode when the local space occupancy input(s) (ZN-OCC) indicate that the space is occupied or when the input from the System Scheduler (SYS-OCC) is occupied.

(2) Unoccupied: The VAV box DDC Hardware shall be in the Unoccupied Mode when the local space occupancy input(s) (ZN-OCC) indicate that the space is unoccupied and the input from the System Scheduler (SYS-OCC) is unoccupied.

b. Safeties: This system has no safeties.

c. Zone Temperature Control

(1) In the Occupied Mode the zone temperature setpoint (ZN-T-SP) shall be at the configured setpoint or at the occupant-adjustable setpoint via the wall-mounted thermostat, as shown. The DDC Hardware shall modulate the VAV box damper to maintain VAV box supply air flow (VAV-SA-F) at setpoint as measured by a multi-point flow sensing element at the inlet to the VAV box. Sequencing shall be as shown: Upon a rise in zone temperature (ZN-T) above zone setpoint (ZN-T-SP), subject to the zone temperature setpoint deadband as shown, the airflow setpoint shall be adjusted between minimum and maximum flow based on the difference between zone temperature and zone temperature setpoint as shown.

(2) In the Unoccupied Mode the VAV box damper shall be at its

minimum position.

3.3.3.2 Zone Temperature Control - VAV Box with Reheat

Install DDC hardware to perform this Sequence of Operation and to provide SNVT inputs, outputs and alarms as specified and shown on the Points Schedule. Unless otherwise specified, all modulating control shall be proportional-integral (PI) control.

a. Occupancy Modes:

(1) Occupied: The VAV box DDC Hardware shall be in the Occupied Mode when the local space occupancy input(s) (ZN-OCC) indicate that the space is occupied or when the input from the System Scheduler (SYS-OCC) is occupied.

(2) Unoccupied: The VAV box DDC Hardware shall be in the Unoccupied Mode when the local space occupancy input(s) (ZN-OCC) indicate that the space is unoccupied and the input from the System Scheduler (SYS-OCC) is unoccupied.

b. Safeties: VAV boxes with electric resistance heating elements shall require proof of air flow before activating the heating elements.

c. Zone Temperature Control:

(1) In the Occupied Mode the zone temperature setpoint (ZN-T-SP) shall be at the configured setpoint or at the occupant-adjustable setpoint via the wall-mounted thermostat, as shown.

(2) In the Unoccupied Mode the zone temperature setpoint (ZN-T-SP) shall be at the configured setpoint as shown.

(3) The DDC Hardware shall modulate the VAV box damper to maintain VAV box supply air flow (VAV-SA-F) at setpoint as measured by a multi-point flow sensing element at the inlet to the VAV box. Sequencing shall be as shown: Upon a rise in zone temperature above zone temperature setpoint (ZN-T-SP), subject to the zone temperature setpoint deadband as shown, the airflow setpoint shall be adjusted between minimum and maximum flow based on the difference between zone temperature and zone temperature setpoint as shown. Upon a fall in zone temperature below zone temperature setpoint, subject to the deadband as shown, the airflow shall be maintained at a fixed air flow setpoint (with a setting independent of the cooling minimum air flow), and the heating valve shall modulate towards open or the staged electric resistance heating coil(s) shall cycle on in sequence.

3.3.3.3 Unit Heater

Install DDC hardware to perform this Sequence of Operation and to provide SNVT inputs, outputs and alarms as specified and shown on the Points Schedule. Unless otherwise specified, all modulating control shall be proportional-integral (PI) control.

a. Off-Auto Switch

(1) OFF: With the thermostat OFF-AUTO switch in the OFF position, the DDC Hardware shall stop the fan and close the heating control valve.

(2) AUTO: With the thermostat OFF-AUTO switch in the AUTO position, the DDC Hardware shall control the unit in accordance with its Occupancy Mode.

b. Occupancy Modes

(1) Occupied: The unit heater DDC Hardware shall be in the Occupied Mode when the local space occupancy input(s) indicate that the space is occupied or when the input from the System Scheduler is occupied.

(2) Unoccupied: The unit heater DDC Hardware shall be in the Unoccupied Mode when the local space occupancy input(s) indicate that the space is unoccupied and when the input from the System Scheduler is unoccupied.

c. Safeties: The unit shall run subject to the unit manufacturer's safeties.

d. Space Temperature Control

(1) In the Occupied Mode the DDC Hardware shall modulate the heating control valve and cycle the multi-speed fan to maintain space temperature at the configured setpoint or at the occupant-adjustable setpoint via the wall-mounted thermostat, as shown.

(2) In the Unoccupied Mode the DDC Hardware shall modulate the heating control valve and cycle the multi-speed fan to maintain space temperature at the configured setpoint as shown.

3.4 START-UP AND START-UP TEST

Perform the following startup tests for each control system to ensure that the described control system components are installed and functioning in accordance with this specification.

a. General: Adjust, calibrate, measure, program, configure, set the time schedules, set alarms, and otherwise perform all necessary actions to ensure that the systems function as specified and shown in the sequence of operation and other contract documents.

b. Systems Check: An item-by-item check shall be performed for each HVAC system;

(1) Step 1 - System Inspection: With the system shut down, it shall be verified that power and main air are available where required and that all output devices are in their failsafe and normal positions. Each local display panel [and each M&C Client] shall be inspected to verify that all displays indicate shutdown conditions.

(2) Step 2 - Calibration Accuracy Check: A two-point accuracy

check of the calibration of each HVAC control system sensing element and transmitter shall be performed by comparing the SNVT output from the DDC Hardware the sensor is connected to the actual value of the variable measured at the sensing element. Digital indicating test instruments shall be used, such as digital thermometers, motor-driven psychrometers, and tachometers. The test instruments shall be at least twice as accurate as the specified sensor accuracy. The calibration of the test instruments shall be traceable to National Institute Of Standards And Technology standards. The first check point shall be with the HVAC system in the shutdown condition, and the second check point shall be with the HVAC system in an operational condition. Calibration checks shall verify that the sensing element-to-DDC system readout accuracies at two points are within the specified product accuracy tolerances. If not, the device shall be recalibrated or replaced and the calibration check repeated.

(3) Step 3 - Actuator Range Check: With the system running, a signal shall be applied to each actuator through the DDC Hardware controller. Proper operation of the actuators and positioners for all actuated devices shall be verified and the signal levels shall be recorded for the extreme positions of each device. The signal shall be varied from live zero to full range, and it shall be verified that the actuators travel from zero stroke to full stroke within the signal range. Where applicable, it shall be verified that all sequenced actuators move from zero stroke to full stroke in the proper direction, and move the connected device in the proper direction from one extreme position to the other.

c. Weather Dependent Test: Weather dependent test procedures that cannot be performed by simulation shall be performed in the appropriate climatic season. When simulation is used, the actual results shall be verified in the appropriate season.

d. Test Report: Upon completion of the Start-Up Test, prepare and submit a Start-Up and Start-Up Testing Report documenting the results of the tests performed and certifying that the system is installed and functioning in accordance with this specification, and is ready for the Performance Verification Test (PVT).

3.5 TRAINING

Conduct a training course for 2 operating staff members designated by the Government in the maintenance and operation of the system, including specified hardware and software. The training period, for a total of 12 hours of normal working time, shall be conducted within 30 days after successful completion of the performance verification test. The training course shall be conducted at the project site and the Government reserves the right to videotape the training sessions for later use. Provide audiovisual equipment and 4 sets of all other training materials and supplies. A training day is defined as 8 hours of classroom instruction, including two 15 minute breaks and excluding lunchtime, Monday through Friday, during the daytime shift in effect at the training facility.

3.5.1 Training Documentation

Prepare training documentation consisting of:

a. Course Attendee List: A List of course attendees which shall be developed in coordination with and signed by the Controls/HVAC shop supervisor.

b. Training Manuals: Training manuals shall include an agenda, defined objectives for each lesson, and a detailed description of the subject matter for each lesson. Where the Contractor presents portions of the course material by audiovisuals, copies of those audiovisuals shall be delivered to the Government as a part of the printed training manuals. Training manuals shall be delivered for each trainee with two additional copies delivered for archival at the project site.

3.5.2 Training Course Content

For guidance in planning the required instruction, assume that attendees will have a high school education or equivalent, and are familiar with HVAC systems. The training course shall cover all of the material contained in the Operating and Maintenance Instructions, the layout and location of each controller enclosure, the layout of one of each type of unitary equipment and the locations of each, the location of each control device external to the panels, the location of the compressed air station, preventive maintenance, troubleshooting, diagnostics, calibration, adjustment, commissioning, tuning, repair procedures, use of LNS Plug-ins, and use of the GPPC Programming software. Typical systems and similar systems may be treated as a group, with instruction on the physical layout of one such system. The results of the performance verification test and the Start-Up and Start-Up Testing Report shall be presented as benchmarks of HVAC control system performance by which to measure operation and maintenance effectiveness.

3.6 PERFORMANCE VERIFICATION TEST (PVT)

3.6.1 PVT Procedures

The performance verification test procedures shall explain, step-by-step, the actions and expected results that will demonstrate that the control system performs in accordance with the sequences of operation, and other contract documents. The PVT shall include inlet and outlet air temperature measurements for all AHU-dependent terminal units. The PVT Procedure shall describe a methodology to measure and trend the network bandwidth usage on the network backbone and compare it to the Bandwidth Usage Calculation submittal. A control system performance verification test equipment list shall be included that lists the equipment to be used during performance verification testing. The list shall include manufacturer name, model number, equipment function, the date of the latest calibration, and the results of the latest calibration.

3.6.2 PVT Execution

Demonstrate compliance of the control system with the contract documents. Using test plans and procedures approved by the Government, demonstrate all physical and functional requirements of the project. The performance verification test shall show, step-by-step, the actions and results demonstrating that the control systems perform in accordance with the sequences of operation. The performance verification test shall measure and trend the Network Bandwidth Usage and compare it to the Bandwidth Usage Calculation submittal. The performance verification test shall not be started until after receipt of written permission by the Government, based

on Government approval of the Start-Up and Start-Up Testing Report and completion of balancing. The tests shall not be conducted during scheduled seasonal off periods of base heating and cooling systems.

3.6.3 PVT Report

Prepare a PVT report documenting all tests performed during the PVT and their results. The PVT report shall include all tests in the PVT Procedures and any other testing performed during the PVT. Failures and repairs shall be documented with test results.

3.7 APPENDIX A

APPENDIX A

QC CHECKLIST

This checklist is not all-inclusive of the requirements of this specification and should not be interpreted as such.

This checklist is for (check one:)

Pre-Construction QC Checklist Submittal (Items 1-5) |____|

Post-Construction QC Checklist Submittal (Items 1-12) |____|

Close-out QC Checklist Submittal (Items 1-19) |____|

Initial each item in the space provided (|____|) verifying that requirement has been met.

Items verified for Pre-Construction, Post-Construction and Closeout QC Checklists Submittal:

- 1 Network bandwidth calculations have been performed, and the backbone type (Ethernet or TP/FT-10) has been determined based on these calculations. |____|
- 2 All DDC Hardware (nodes) are numbered on Control System Schematic Drawings. |____|
- 3 Signal lines on Control System Schematic are labeled with the signal type. |____|
- 4 Local Display Panel (LDP) Locations are shown on Control System Schematic drawings. |____|
- 5 Points Schedule drawings have been sub-divided by device (DDC Hardware), including DDC Hardware node numbers. |____|

Items verified for Post-Construction and Closeout QC Checklist Submittal:

- 6 All DDC Hardware is installed on a TP/FT-10 local control bus. |____|
- 7 All Application Specific Controllers (ASCs) are LonMark certified. |____|
- 8 Communication between DDC Hardware is only via CEA-709.1B using SNVTs. Other protocols and network variables other than SNVTs have not been used. |____|
- 9 Explicit messaging has not been used. |____|
- 10 System Scheduler functionality has been installed for all HVAC systems and default schedules have been configured at each System Scheduler. |____|
- 11 All sequences are performed as specified using DDC Hardware. |____|
- 12 Training schedule and course attendee list has been |____|

QC CHECKLIST

developed and coordinated with shops and submitted.

Items verified for Closeout QC Checklists Submittal:

- | | | |
|----|--|------|
| 13 | Final As-built Drawings, including the Points Schedule drawings accurately represent the final installed system. | ____ |
| 14 | LonWorks Network Services (LNS) Database is up-to-date and accurately represents the final installed system. | ____ |
| 15 | LNS Plug-ins have been submitted for all ASCs. | ____ |
| 16 | Programming software has been submitted for all General Purpose Programmable Controllers (GPPCs). | ____ |
| 17 | All software has been licensed to the Government | ____ |
| 18 | O&M Instructions have been completed and submitted. | ____ |
| 19 | Training course has been completed. | ____ |

(QC Representative Signature)

(Date)

-- End of Section --

ATEC Base VAV Controller & ATEC VAV Reheat Controller



Description

The new ATEC (Actuating Terminal Equipment Controller) Variable Air Volume Controllers provide direct digital control of pressure-independent, variable-air-volume zone-level routines. The ATEC controllers can operate stand-alone or can be networked to perform complex HVAC control, monitoring and energy management functions. The ATEC controllers are designed to reside on the Siemens Building Technologies APOGEE® Building Automation System.

Features

- Controller integrated with actuator for ease of installation;
- Automated checkout procedure for ease of startup/commissioning and troubleshooting;
- PID control of HVAC systems to minimize offset and maintain tighter set point control;
- HVAC diagnostic capability at the BLN level using the TBC Test Tool in CT 4.8;

- ATEC Base VAV Controller requires only 3.5 VA, an advantage when sizing electrical capacity;
- Suitable for installation in plenum areas;
- Set points and control parameters assigned and changed locally or remotely;
- Electrically Erasable Programmable Read Only Memory (EEPROM) used for storing set points and control parameters—no battery backup required;
- Return from power failure without operator intervention;
- Uses proven APOGEE Automation System DDC architecture;
- No calibration required, thereby reducing maintenance costs.

Applications

Operating independently, or as part of the APOGEE Building Automation System, the ATEC VAV Controller can control the following VAV pressure-independent zone applications.

ATEC Base VAV Controller:

- VAV Cooling Only (application 2520—similar to 2020 for the ATEC);
- VAV Cooling or Heating (application 2521—similar 2021).
- Slave Mode (application 2486)

ATEC VAV with Reheat Controller:

- VAV Cooling Only (application 2500—similar to 2020);
- VAV Cooling or Heating (application 2501—similar to 2021);

- VAV with Electric Reheat or Baseboard Radiation (application 2522—similar to 2022);
- VAV with Hot Water Reheat (only one reheat valve) (application 2523—similar to 2023 with one reheat valve);
- VAV Series Fan Powered with one stage of Electric Reheat (application 2524—similar to 2024 with one stage of electric reheat);
- VAV Parallel Fan Powered with one stage of Electric Reheat (application 2526—similar to 2026 with one stage of electric reheat);
- Slave Mode (application 2473).

Control algorithms are preprogrammed. The controller is ready to operate after selecting the application and assigning the unit's controller address. If desired, the operator may adjust the air volume set points in cfm (l/s), room temperature set points, and other parameters. The controller is designed for operation and modification without vendor assistance.

Hardware

Controller Board

The ATEC consists of an electronic controller, a differential pressure transducer, and a damper actuator assembly. This controller provides all wiring terminations for system and local communication and power. The cable from the room sensor (purchased separately) connects to an RJ-11 jack on the controller. All other connections are removable terminal blocks.

The ATEC Base VAV Controller has no external, wireable I/O. The ATEC VAV with Reheat Controller, however, has additional I/O: 2 AI/DIs and 2 DOs.

In addition to controlling the integrated damper actuator, the controller interfaces with the following external devices (purchased separately):

- Averaging air velocity sensor provided by VAV terminal unit manufacturers;
- Room temperature sensor with optional set point dial and night override button;
- Service and commissioning tools;
- APOGEE Building Automation System.

Room Sensor

The room sensor connection to the controller board consists of a quick-connect RJ-11 jack. This streamlines the installation and reduces the ATEC's

start-up time. See the Room Temperature Sensors Technical Specification Sheet, P/N 149-312P25, for more information.

Differential Pressure Sensor

The Differential Pressure Sensor (purchased separately) is easily connected to the box's air-velocity sensing elements to provide measurement of the differential pressure. The measured value is converted to actual airflow in cfm (l/s) by the ATEC controller.

Specifications

Controller & Actuator		
Power Requirements:	Base:	Reheat:
Power Source	24 Vac +/- 15%	24 Vac +/- 15%
Frequency	50/60 Hz	50/60 Hz
Power Consumption	3.5 VA	3.5 VA plus loads
Operating Temperature Range	+32°F to +122°F (0°C to +50°C)	
Storage Temperature Range	-20°F to +140°F (-29°C to +60°C)	
Humidity Range	10% to 95% non-condensing	
Regulatory Compliance	UL/CUL 916 PAZX/PAZX7 (Enclosed Energy Management) FCC Part 15, Class B CSA-Std. C22.2 No 205 CE Mark; C-Tick	
Dimensions	5-9/16" H x 2-15/16" W x 4-3/16" D (142 mm x 75 mm x 106 mm)	
Weight	1.26 lbs (.572 kg)	
Actuator Torque	44 lb.-in. (5Nm)	
Run time for 90° opening or closing at:		
50 Hz	108 sec.	
60 Hz	90 sec.	
Nom. Angle of Rotation	90°	
Max. Angle of Rotation	95°	
Actuator Shaft Size	3/8" to 5/8" (8 to 16 mm) Dia 1/4" to 1/2" (6 to 13 mm) Sq.	
Minimum Shaft Length	3/4" (20 mm)	

Transformer Requirements and Recommended Voltages

Type	Class 2, 24 VAC, 50/60 Hz, SELV, PELV
------	---------------------------------------

Ordering Information

Controllers	
Description	Product Number
ATEC Base VAV Controller	550-400
ATEC Base VAV Controller— 10 pack	550-400P10
1 AVS Air Velocity Sensor (0—5,664 FPM)	
1 RS Tool/10 K Ω Thermistor Room Sensor Module Connection Port	
ATEC VAV with Reheat Controller	550-405
ATEC VAV with Reheat Controller— 10 pack	550-405P10
2 AI/DI 100 K Ω Thermistor or Dry Contact	
2 DO 12 VA, 24Vac Triac	
1 AVS Air Velocity Sensor (0—5,664 FPM)	
1 RS Tool/10 K Ω Thermistor Room Sensor Module Connection Port	
Documentation	Product Number
ATEC Owner's Manual	125-3209
Room Temperature Sensors Technical Specification Sheet	149-312P25

Information in this document is based on specifications believed correct at the time of publication. The right is reserved to make changes as design improvements are introduced. APOGEE is a registered trademark of Siemens Building Technologies, Inc. © 2004 Siemens Building Technologies, Inc.

QPA20... Series Room Air Quality Sensors

Description

The QPA20... series room air quality sensors optimize room comfort by enabling demand-controlled ventilation. The sensors can acquire: CO₂ and volatile organic compound (VOC) concentrations, relative humidity, and temperature. Models are available for CO₂, CO₂/VOC, CO₂/T, and CO₂/T/RH.

The sensor evaluates the CO₂/VOC concentrations and transforms it to a 0 to 10 Vdc linear proportional output signal.

For models with humidity, a capacitive humidity sensing element changes capacitance as a function of the relative humidity. An electronic measuring circuit converts the humidity signal to a continuous 0 to 10 Vdc signal that corresponds to a relative humidity range of 0 to 100%. For models with temperature, the sensor acquires room temperature with a sensing element that changes electrical resistance as a function of the temperature. The resistance is converted to an active 0 to 10 Vdc output signal that corresponds to a temperature range of 32°F to 122°F (0°C to 50°C) or -31°F to 95°F (-35°C to 35°C).

Sensors with an LCD window display the following measured values:

- CO₂ in ppm
- CO₂ and VOC as a bar chart (4 bars ≈ 2V, 20 bars ≈ 10V)
- Temperature in °C or °F
- Relative humidity in %

The wall-mounted sensors are suited for use with all systems and devices capable of acquiring and handling a 0 to 10 Vdc output signal.

Features

- Multisensor for CO₂/VOC, temperature, and humidity-temperature
- Maintenance-free infrared CO₂ sensing element, VOC sensing element based on a heated tin dioxide semiconductor
- 24 Vac operating voltage, 0 to 10 Vdc output signals



QPA20... Series Room Air Quality Sensor.



QPA20... Series Room Air Quality Sensor with Display.

General Specifications

Power Supply:

Operating voltage (SELV): 24 Vac \pm 20%
 Frequency: 50/60 Hz
 Power consumption: \leq 2 VA

Electrical:

Screw terminals: 2 \times 16 AWG or 1 \times 14 AWG

Environmental:

Temperature

Operating: 23°F to 113°F (-5° to 45°C)
 Storage: -13°F to 158°F (-25° to 70°C)

Humidity:

Operating: 0 to 95% rh (noncondensing)
 Storage: <95% rh

Physical:

Mounting: In 2 \times 4 inch (5 \times 10 cm) electrical conduit box

Weight in lb (kg):

Without display: 0.22 lb (0.10 kg)
 With display: 0.26 lb (0.12 kg)

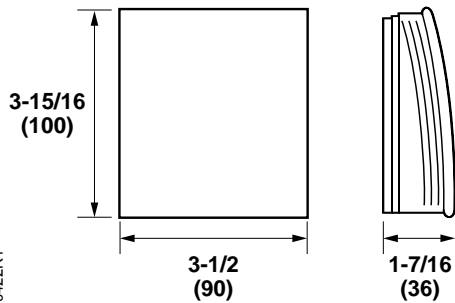

Dimensions in Inches (mm).

Product Numbers and Specifications

Product Number	Specification						
	QPA2000	QPA2002	QPA2002D	QPA2060	QPA2060D	QPA2062	QPA2062D
CO ₂ measuring range: 0 to 2000 ppm Accuracy: \leq ±50 ppm +2% of measured value Output signal: 0 to 10 Vdc, linear Recalibration free: 8 years	•	•	•	•	•	•	•
VOC sensitivity: Low (R1), Normal (R2), High (R3)		•	•				
Temperature measuring range (slope and intercept): R2 and R3: 32°F to 122°F (0°C to 50°C) R1: -31°F to 95°F (-35°C to 35°C) Temperature measuring element: QPA2060: PT1000 QPA2062: NTC 10 k Ω Measuring accuracy in the range of: -31°F to 59°F (-35°C to 15°C): \pm 1K 59°F to 95°F (15°C to 35°C): \pm 0.8K 95°F to 122°F (35°C to 50°C): \pm 1K				•	•	•	•
Humidity range of use: 0 to 95% rh (noncondensing) Humidity measuring range: (slope and intercept) 0 to 100% rh Measuring accuracy at 73°F (23°C), 24 Vac: 0 to 30% rh: \pm 5% rh 30 to 70% rh: \pm 3% rh 70 to 95% rh: \pm 5% rh						•	•
Display (LCD) of measured value			•	•			•

Ordering Information

UNIVERSAL SENSOR PROGRAM			Q	P	A	2	0	x	x	x
TYPE	SENSOR	Q								
MEASURING FAMILY	CO ₂ /VOC	P								
APPLICATION/LOCATION	ROOM	A								
SENSOR TYPE	CO ₂	2								
HOUSING TYPE	CO ₂ HOUSING	0								
TEMPERATURE OUTPUT SIGNAL	NONE	0								
	0 TO 10 VOLT	6								
RH SIGNAL PRESENT										
CO ₂ OR VOC ONLY:	0 TO 10 VOLT	0								
CO ₂ /VOC AND RH:	0 TO 10 VOLT	2								
SEPARATOR										
FEATURE DESCRIPTION - ROOM TYPES										
	WITHOUT DISPLAY	<BLANK>								
	WITH LCD DISPLAY	D								

Information in this document is based on specifications believed correct at the time of publication. The right is reserved to make changes as design improvements are introduced. Other product or company names mentioned herein may be the trademarks of their respective owners.
 © 2007 Siemens Building Technologies, Inc.

QPM21... Series Duct Air Quality Sensors

Description

The QPM21... Series Duct Air Quality Sensors optimize room comfort by enabling demand-controlled ventilation. The sensors can acquire: CO₂ and volatile organic compound (VOC) concentrations, relative humidity, and temperature. Models are available for CO₂, CO₂/VOC, CO₂/T, and CO₂/T/RH.

The sensor evaluates the CO₂/VOC concentrations and transforms it to a 0 to 10 Vdc linear proportional output signal.

For models with humidity, a capacitive humidity sensing element changes capacitance as a function of the relative humidity. An electronic measuring circuit converts the humidity signal to a continuous 0 to 10 Vdc signal that corresponds to a relative humidity range of 0 to 100%. For models with temperature, the sensor acquires room temperature with a sensing element that changes electrical resistance as a function of the temperature. The resistance is converted to an active 0 to 10 Vdc output signal that corresponds to a temperature range of 32°F to 122°F (0°C to 50°C) or -31°F to 95°F (-35°C to 35°C).

The duct-mounted sensors are suited for use with all systems and devices capable of acquiring and handling a 0 to 10 Vdc output signal.

Features

- Multisensor for CO₂/VOC, temperature, and humidity-temperature.
- Maintenance-free infrared CO₂ sensing element, VOC sensing element based on a heated tin dioxide semiconductor.
- 24 Vac operating voltage, 0 to 10 Vdc output signals.



QPM2100/2102 Duct Air Quality Sensors and QPM2102D Duct Air Quality Sensor with Display.

Ordering Information

CO ₂ DUCT SENSOR PART NUMBER KEY			Q	P	M	2	1	x	x
TYPE	SENSOR	Q							
MEASURING FAMILY	CO ₂ /VOC	P							
APPLICATION/LOCATION	DUCT	M							
SENSOR TYPE	CO ₂	2							
HOUSING TYPE	DUCT HOUSING	1							
OUTPUTS (0 TO 10 VOLT)	CO ₂ ONLY	00							
	CO ₂ AND VOC	02							
	CO ₂ AND TEMP	60							
	CO ₂ , TEMP AND RH	62							
FEATURE DESCRIPTION	NO DISPLAY	-							(LEAVE BLANK)
	LCD DISPLAY	D							

NOTE: QPM2100D is not available at this time.

Product Numbers and Specifications

Product Number \ Specification	QPM2100	QPM2102	QPM2102D	QPM2160	QPM2160D	QPM2162	QPM2162D
CO ₂ measuring range: 0 to 2000 ppm Accuracy: $\leq \pm 50$ ppm +2% of measured value Output signal: 0 to 10 Vdc, linear Recalibration free: 8 years	•	•	•	•	•	•	•
VOC sensitivity: Low (R1), Normal (R2), High (R3)		•	•				
Temperature range of use: -31°F to 113°F (-35°C to 45°C) Temperature measuring range (slope and intercept): R2 and R3: 23°F to 113°F (-5°C to 45°C) R1: -31°F to 95°F (-35°C to 35°C) Temperature measuring element: NTC 10K Ω Measuring accuracy in the range of: 59°F to 95°F (15°C to 35°C): $\pm 1.4^\circ\text{F}$ ($+0.8^\circ\text{C}$) outside the above range, between: -31°F to 122°F (-35°C to 50°C): $\pm 1.8^\circ\text{F}$ ($+1^\circ\text{C}$)				•	•	•	•
Humidity range of use: 0 to 95% rh (noncondensing) Humidity measuring range (slope and intercept): 0 to 100% rh Measuring accuracy at 73°F (23°C), 24 Vac: 30 to 70% rh: $\pm 3\%$ rh outside the above range, between: 0 to 95% rh: $\pm 5\%$ rh						•	•
Display (LCD) of measured value			•	•			•

General Specifications

Power Supply:

Operating voltage (SELV): 24 Vac $\pm 20\%$

Frequency: 50/60 Hz

Power consumption: ≤ 2 VA

Electrical:

Screw terminals: 2 \times 16 AWG or 1 \times 14 AWG

Environmental:

Transport:

Temperature: -13°F to 158°F

(-25°C to 70°C)

Humidity: < 95% rh

Physical:

Weight (including packaging):

QPM2100/2102: 0.54 lb (0.247 kg)

QPM2160/2162: 0.56 lb (0.252 kg)

QPM2102D: 0.59 lb (0.267 kg)

QPM2150D/2162D: 0.60 lb (0.272 kg)

Dimensions

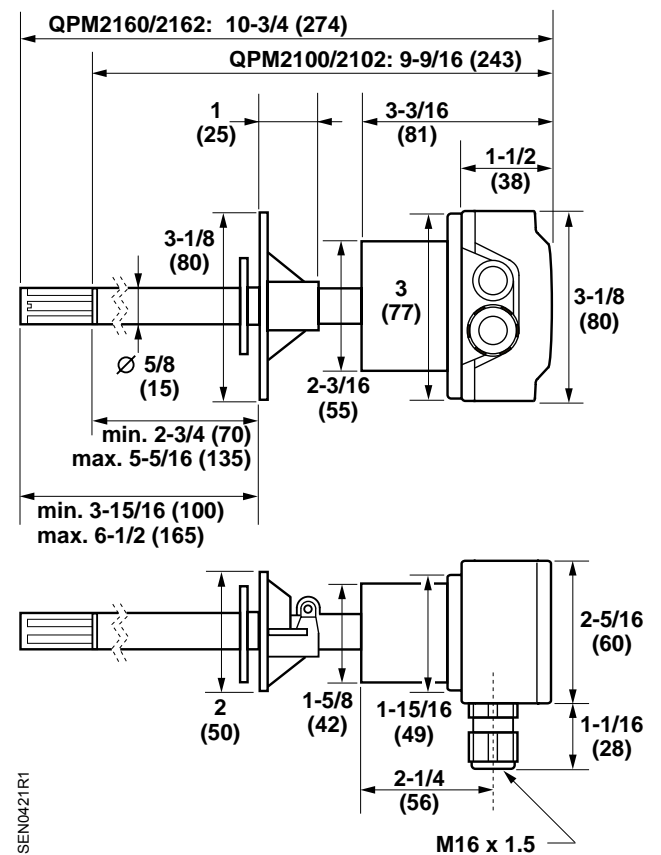

Dimensions in Inches (mm).

Information in this document is based on specifications believed correct at the time of publication. The right is reserved to make changes as design improvements are introduced. Products or company names mentioned herein may be the trademarks of their respective owners.
© 2009 Siemens Building Technologies, Inc.

PXC Modular Series



Figure 1. PXC Modular.

Description

The PXC Modular (Programmable Controller - Modular) is an integral part of the APOGEE[®] Automation System. It is a high performance, modular Direct Digital Control (DDC) supervisory field panel.

The field panel operates stand-alone or networked to perform complex control, monitoring, and energy management functions without relying on a higher level processor.

- Up to 100 modular field panels communicate on a peer-to-peer network.
- With the addition of TX-I/O modules and a TX-I/O Power Supply on a self-forming bus, the PXC Modular can directly control up to 500 points.

With the addition of an Expansion Module, the PXC Modular also provides central monitoring and control for distributed Field Level Network (FLN) devices.

Features

- Modular hardware components match initial control requirements while providing for future expansion.
- DIN rail mounting and removable terminal blocks simplify installation and servicing.
- Proven program sequences to match equipment control applications.
- Sophisticated Adaptive Control, a closed loop control algorithm that auto-adjusts to compensate for load/seasonal changes.
- Built-in energy management applications and DDC programs for complete facility management.
- Comprehensive alarm management, historical data trend collection, operator control and monitoring functions.
- Support for peer-to-peer communications over Industry standard 10/100Base-T TCP/IP networks.

Hardware

PXC Modular

- The PXC Modular is a microprocessor-based multi-tasking platform for program execution and communication with other field panels. It scans field data, optimizes control parameters, and manages operator requests for data in seconds.
- The program and database information stored in the PXC Modular memory is battery-backed. This eliminates the need for time-consuming program and database re-entry in the event of an extended power failure. When battery replacement is necessary, the PXC Modular illuminates a “battery low” status LED and can send an alarm message to selected printers or terminals.
- The PXC Modular firmware, including the operating system, is stored in non-volatile flash memory.
- The PXC Modular provides both an Ethernet port as well as an RS-485 port for communication on Automation Level Networks using either TCP/IP or RS-485.
- An HMI RS-232 port is provided as a connection to a laptop computer for local operation and engineering.
- LEDs provide instant visual indication of overall operation, network communication, and low battery warning.
- Two self-forming buses are an integral part of the flexibility of the PXC Modular. A self-forming bus to the right of the controller supports up to 500 points through TX-I/O™ modules. Another self-forming bus to the left of the controller supports hardware connection to subsystems through Expansion Modules.

TX-I/O Modules

TX-I/O Modules are modular expansion I/O consisting of an electronics module and terminal base. The electronics modules perform A/D or D/A conversion, signal processing, and point monitoring and command output through communication with the PXC Modular. The terminal bases provide for termination of field wiring and connection of a self-forming bus. For more information, see *TX-I/O* (149-476).

The TX-I/O Power Supply provides power for TX-I/O modules and peripheral devices. Multiple Power Modules can be used in parallel to meet the power needs of large concentrations of I/O points (Figure 2 and Figure 3). For more information, see *TX-I/O Power Supplies* (149-476).

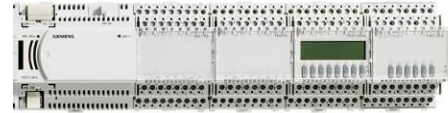

Figure 2. TX-I/O Power Supply and TX-I/O Modules.



Figure 3. PXC Modular, TX-I/O Power Supply, and TX-I/O Modules.

PXC Modular Expansion Module

The PXC Modular Expansion Module (see Figure 4) provides the hardware connection for Field Level Network (FLN) devices. Using the Triple RS-485 Expansion Module, the PXC Modular supports up to three RS-485 networks of Field Level Network devices (see Figure 5).



Figure 4. RS-485 Expansion Module.



Figure 5. RS-485 Expansion Module and PXC Modular.

Modular Control Panels with Application Flexibility

The PXC Modular is a high performance controller with extensive flexibility to customize each field panel with the exact hardware and program for the application. As a result, the user only purchases what is needed.

For example, in monitoring applications, the control panel can be customized with the number and type of points to match the sensor devices. For monitoring and controlling a large number of (on-off) fans or

motors, more digital points can be added (see Figure 6).



Figure 6. PXC Modular, TX-I/O Power Supply, and TX-I/O Modules.

Alternately, if no local point control is required, the PXC Modular can be used to monitor and control Field Level Network devices using the Expansion Modules (see Figure 7).



Figure 7. RS-485 Expansion Module and PXC Modular.

Of course, the PXC Modular can be used for both direct point monitoring and control **and** as a system controller for Field Level Network devices (see Figure 8).



Figure 8. RS-485 Expansion Module, PXC Modular, TX-I/O Power Supply, and TX-I/O Modules.

The control program for each field panel is customized to exactly match the application. Proven Powers Process Control Language (PPCL), a "BASIC" type programming language, provides direct digital control and energy management sequences to precisely control equipment and optimize energy usage.

In a stand-alone configuration, the PXC Modular can fulfill all requirements of a supervisory network coordinator by managing operation schedules and alarms and communicating for the connected devices.

Global Information Access

Each PXC Modular is equipped with an RS-232 port. This port supports the connection of a computer. Devices connected to the terminal port gain global information access.

Multiple Operator Access

Multiple operators can access the network simultaneously. When using the Ethernet ALN option, multiple operators may access the controller through concurrent Telnet sessions and/or local operator terminal ports.

Menu Prompted, English Language Operator Interface

The PXC Modular field panel includes a simple, yet powerful menu driven English Language Operator Interface that provides, among other things:

- Point monitoring and display
- Point commanding
- Historical trend collection and display for multiple points
- Equipment scheduling
- Program editing and modification via Powers Process Control Language (PPCL)
- Alarm reporting and acknowledgment
- Continual display of dynamic information

Built-in Direct Digital Control Routines

The PXC Modular provides stand-alone Direct Digital Control (DDC) to deliver precise HVAC control and comprehensive information about system operation. It receives information from sensors in the building, processes the information, and directly controls the equipment. The following functions are available in the PXC Modular:

- Adaptive Control, an auto-adjusting closed loop control algorithm. Provides more efficient, adaptive, robust, fast, and stable control than the traditional PID control algorithm. Superior in terms of response time, holding steady state, and minimizing error, oscillations, and actuator repositioning.
- Closed Loop Proportional, Integral and Derivative (PID) control.
- Logical sequencing.
- Alarm detection and reporting.
- Reset schedules.

Built-in Energy Management Applications

The following applications are programmed in the PXC Modular and require simple parameter input for implementation:

- Peak demand limiting
- Start-Stop time optimization
- Equipment scheduling, optimization and sequencing
- Duty cycling
- Economizer control

Licensable Options

The following features are available on the PXC Modular P2 controllers and require a license for implementation:

- Field Panel GO
- Virtual AEM

Specifications

Dimensions

PXC Modular Series	7.56" L × 3.54" W × 2.76" D (192 mm L × 90 mm W × 70 mm D)
Expansion Module with three P1 RS-485 FLN connections	1.26" L × 3.54" W × 2.76" D (32 mm L × 90 mm W × 70 mm D)

Electrical, Processor, Battery, and Memory

Power Consumption	24 VA @ 24 Vac
Processor	MPC885 (PowerPC®)
Processor Clock Speed	133 MHz
Memory	72 MB (64 MB SDRAM, 8 MB Flash ROM)
Secure Digital Input/Output (SDIO) card	Expandable or removable non-volatile memory
Battery backup of SDRAM	30 days (accumulated) AA (LR6) 1.5 Volt Alkaline (non-rechargeable)
Battery backup of Real Time Clock	12 months (accumulated) Cell coin 3 Volt lithium

Communication

Ethernet Automation Level Network (EALN) port BACnet I/P Ethernet Automation Level Network port	10Base-T or 100Base-TX compliant
RS-485 Automation Level Network (ALN) port	1200 bps to 115.2 Kbps
Expansion Bus for support of sub-system networks	1200 bps to 115.2 Kbps
TX-I/O Self forming bus connection	115.2 Kbps
Human-Machine Interface (HMI) port	RS-232 compliant
USB Device Port	Standard 1.1 and 2.0 USB device port, full speed 12 Mbps, low speed 1.5 Mbps, Type B connector
USB Host port	Standard 1.1 and 2.0 USB host port, full speed 12 Mbps, low speed 1.5 Mbps, Type A connector

Electrical Rating

AC Power	NEC Class 2
Communication	NEC Class 2

Operating Environment

Ambient operating temperature	32°F to 122°F (0°C to 50°C), <93% rh, non-condensing
Ambient operating environment	Operate in a dry location, which is protected from exposure to salt spray or other corrosive elements. Exposure to flammable or explosive vapors must be prevented.
Shipping and Storage environment	-40°F to +185°F (-40°C to +85°C) <93% rh, non-condensing
Shipping environment	-13°F to 158°F (-25°C to 70°C), 5% to 95% rh, non-condensing
Mounting Surface	Building wall or structural member

Agency Listings

UL	UL 864 UUKL Smoke Control Equipment UL 864 UUKL7 Smoke Control Equipment CAN/ULC-S527-M8 UL 916 PAZX UL 916 PAZX7
Agency Compliance	FCC Compliance Australian EMC Framework European EMC Directive (CE) – with enclosure

Product Ordering Information

Description	Product Number
PXC MOD, P2, 96 NODE, APOGEE	PXC00-PE96.A
PXC MOD, P2, TX-I/O, 96 NODE, APOGEE	PXC100-PE96.A
PXC MOD, BACnet, 96 NODE, APOGEE	PXC00-E96.A
PXC MOD, BACnet, TX-I/O, 96 NODE, APOGEE	PXC100-E96.A
Add support for TX-I/O	PXF-TXIO.A
Virtual AEM License	LSM-VAEM
Field Panel GO License	LSM-FPGO
Expansion Module, three RS-485 connections	PXX-485.3

Document Ordering Information

Description	Document Number
PXC Modular Series Owner's Manual	125-3582
Powers Process Control Language (PPCL) User's Manual	125-1896

Information in this document is based on specifications believed correct at the time of publication. The right is reserved to make changes as design improvements are introduced. APOGEE is a registered trademark of Siemens Building Technologies, Inc. Other product or company names mentioned herein may be the trademarks of their respective owners. © 2008 Siemens Building Technologies, Inc.

TX-I/O Product Range

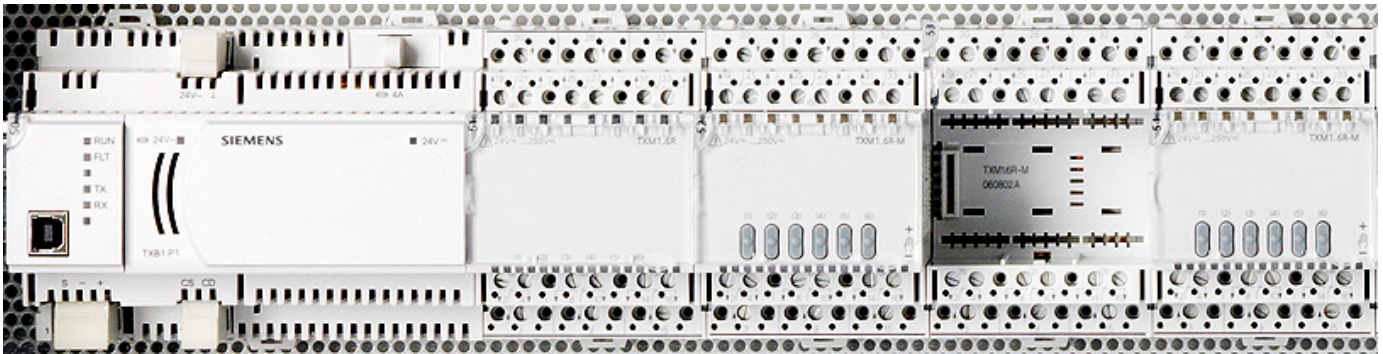

Description

TX-I/O™ is a line of I/O modules with associated power and communication modules for use within the APOGEE system. TX-I/O products include eight types of I/O modules, modular TX-I/O Power Supplies, Bus Connection Modules, and Bus Interface Modules.

TX-I/O Modules provide I/O points for APOGEE based upon TX-I/O Technology. TX-I/O Technology provides flexibility of point types, tremendous flexibility of signal types and support for manual operation.

There are eight types of TX-I/O modules:

- 8 point DI module (TXM1.8D)
- 16 point DI module (TXM1.16D)
- 6 point DO with Relay module (TXM1.6R)
- 6 point DO with Relay and Manual Override module (TXM1.6R-M)
- 8 point Universal module (TXM1.8U)
- 8 point Universal with local override/identification device (LOID) module (TXM1.8U-ML)
- 8 point Super Universal module (TXM1.8X)
- 8 point Super Universal with LOID module (TXM1.8X-ML)

Features

The *self-forming TX-I/O bus* transmits power as well as communication signals. The TX-I/O bus can be extended a maximum of 160 feet (50 meters).

Hot-swappable electronic components allow powered electronics to be disconnected and even replaced without removing terminal wiring or disturbing the self-forming bus.

The *removable label holder* allows for customized point labels.

LEDs provide status indication and diagnostic information for the I/O module, as well as for each point on the module.

All TX-I/O modules are also:

- DIN rail mounted
- High density (point count to physical dimensions)
- Hardware addressed with address keys
- Separable into terminal base and plug-in I/O module electronics for:
 - Improved installation workflow, allowing field wiring to be terminated prior to installation of electronics.

- Optimum diagnostics - connected peripheral devices can be measured without affecting or being affected by the I/O module.
- Quick replacement of electronics for service.

Module Introduction

P1 Bus Interface Module (TXB1.P1)

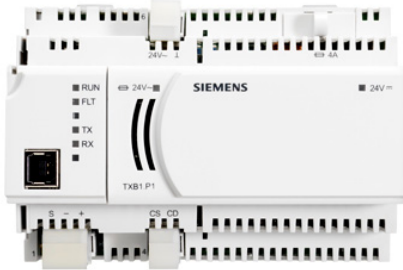

The P1 Bus Interface Module (P1 BIM) provides P1 FLN communication and power for TX-I/O modules. It does not contain application or control for the TX-I/O modules.

Features

- Communication on the P1 FLN or MEC Expansion Bus
- Support for 80 TX-I/O points
- Support for 10 I/O modules
- 24 Vac input
- Generation of 24 Vdc at 600 mA to power TX-I/O modules and peripheral devices
- Transfer of 24 Vac at a maximum of 4A to power peripheral devices
- Plug-in screw terminals
- AC Fuse isolates the peripheral device supply in case of overload or short-circuit. The fuse can be accessed from an installed module.
- Separate LEDs for module operation, FLN communication activity, 24 Vdc present on the TX-I/O bus, and monitoring of the 24 Vac fuse

Digital Input Modules (TXM1.8D and TXM1.16D)

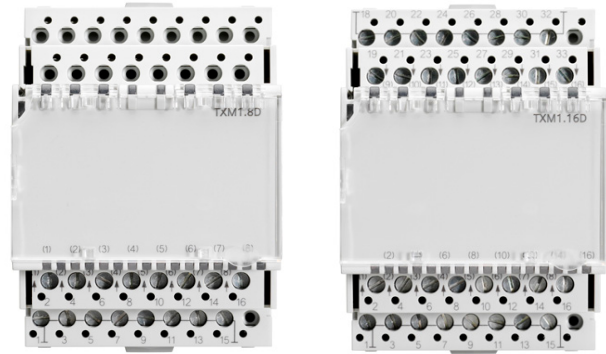

The TXM1.8D and TXM1.16D are dedicated to monitoring, respectively, 8 and 16 digital input points. They monitor status signals from normally open (NO) or normally closed (NC), latched voltage free/dry contacts. All 8 points on the TXM1.8D module as well as 8 of the 16 points on the TXM1.16D module may be used as pulse counters up to 10 Hz. Each input point has a green LED for status indication.

Digital Output Modules (TXM1.6R and TXM1.6R-M)

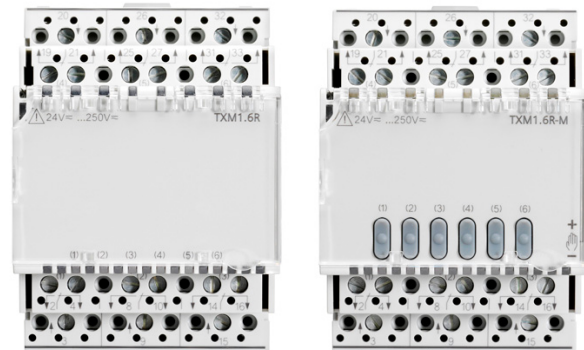

The Digital Output Modules provide six NO or NC (form C), maintained or pulsed, voltage free/dry contacts. The contacts are rated for a maximum of 250 Vac at 4A. Each I/O point has a green LED for status indication.

The TXM1.6R-M module is also equipped with manual override switches. An orange LED per override switch indicates override status individually per point.

Universal Modules (TXM1.8U and TXM1.8U-ML)

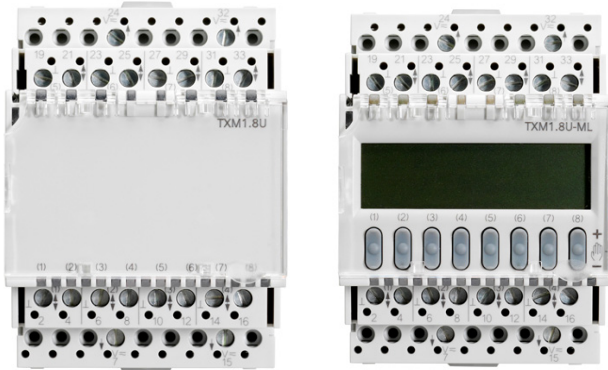

The TXM1.8U and TXM1.8U-ML are universal modules, allowing each of their 8 points to be individually software configured as digital input, analog input, or analog output to best meet the specific application needs.

Features

All Universal modules provide:

- AC supply voltage for peripheral devices such as valves and actuators
- Green LED status per I/O point that varies in intensity according to the voltage and current (directly proportional)

Digital input support includes:

- Voltage free/dry contacts
- Pulse counters up to 25 Hz

Analog input sensor support includes:

- 1k Nickel – Landis & Gyr curve
- 1k Platinum – 375 and 385 coefficient
- 10k and 100k Thermistor – Type II Curve

Active input and output support includes:

- Analog input voltage 0-10 Vdc
- Analog output voltage 0-10 Vdc

NOTE: Active inputs and outputs are permitted on the same module when connected sensors are powered from that module. When sensors are externally powered, active inputs and outputs should be on separate modules.

TXM1.8U-ML modules are also equipped with a local override/identification device (LOID), which includes an LCD signal display. The LCD displays the following information for each IO point:

- Configured signal type
- Symbolic display of process value
- Notification of faulty operation, short circuit, or sensor open circuit

Orange LEDs indicate override status individually per point.

Super Universal Modules (TXM1.8X and TXM1.8X-ML)



TXM1.8X and TXM1.8X-ML Super Universal modules share all of the Universal module features, and also provide:

- Analog input current 4-20 mA
- Analog output current 4-20 mA (four current outputs maximum per module on Points 5 through 8)
- 24 Vdc supply voltage for sensors at a maximum of 200 mA per module

NOTE: Active inputs and outputs are permitted on the same module when connected sensors are powered from that module. When sensors are externally powered, active inputs and outputs should be on separate modules.

TX-I/O Power Supply (TXS1.12F4)

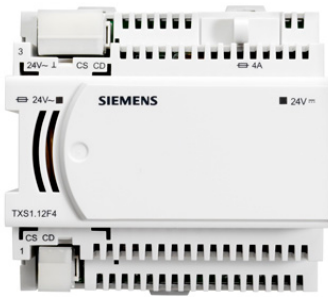

Features

The TX-I/O Power Supply:

- Generates 24 Vdc at 1.2A to power TX-I/O modules and peripheral devices.
- An LED provides an indication of 24 Vdc on the TX-I/O bus.
- Up to 4 TX-I/O Power Supplies can be operated in parallel, with a maximum of two per DIN rail.
- Transfers 24 Vac at 4A to power TX-I/O modules and peripheral devices.
- Can be located within a row of TX-I/O modules or at the beginning of a new DIN rail.
- Routes CS (+24 Vdc Communication Supply) and CD (Communication Data signal) between DIN rails.
- Provides an input point for 24 Vac to power additional peripheral devices.
- Isolates the 24 Vac peripheral device supply in case of overload or short-circuit. The replaceable AC fuse can be accessed from an installed module.
- Indicates the AC fuse status (via LED) for easy diagnostics.

TX-I/O Bus Connection Module (TXS1.EF4)

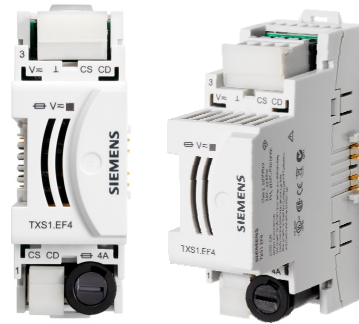

Features

The Bus Connection Module:

- Transfers 24 Vac at 4A to power TX-I/O modules and peripheral devices.
- Can be located within a row of TX-I/O modules or at the beginning of a new DIN rail.
- Routes CS (+24 Vdc Communication Supply) and CD (Communication Data Signal) between DIN rails.
- Provides an input point for 24 Vac to power additional peripheral devices.
- Isolates the 24 Vac peripheral device supply in case of overload or short-circuit. The replaceable AC fuse can be accessed from an installed module.
- Indicates the AC fuse status (via LED) for easy diagnostics.

I/O Functions by Module

TX-I/O™ function	Description	Module type							
		TXM1.8D	TXM1.16D	TXM1.8U	TXM1.8U-ML	TXM1.8X	TXM1.8X-ML	TXM1.6R	TXM1.6R-M
		Maximum number of functions per module							

Digital inputs

Binary Input	Status indication, voltage-free/dry contact	8	16	8	8	8	8		
Counter	Count/accumulator, voltage-free/dry pulse contact,	8	8	8	8	8	8		

Analog Inputs	Temperature LG-Ni1000			8	8	8	8		
	Temperature Pt 1000 375			8	8	8	8		
	Temperature Pt 1000 385			8	8	8	8		
	Temperature (NTC) 10 K			8	8	8	8		
	Temperature (NTC) 100 K			8	8	8	8		
	Voltage, DC 0 ... 10V *			8	8	8	8		
	Current DC 4... 20 mA *					8	8		

Digital outputs

BO OnOff	Latched contact, AC/DC 250V, 4A							6	6
BO Pulse	Pulse							6	6

Analog Outputs	DC 0..10 V *			8	8	8	8		
	DC 4 ... 20 mA *					4	4		

* Active inputs and active outputs (0-10V and 4-20 mA) must be located on different modules if sensors are externally powered.

TX-I/O Network Architecture Examples

The following architecture picture shows TX-I/O modules connected to a P1 BIM located on:

- the Field Level Network
- the MEC Expansion Bus

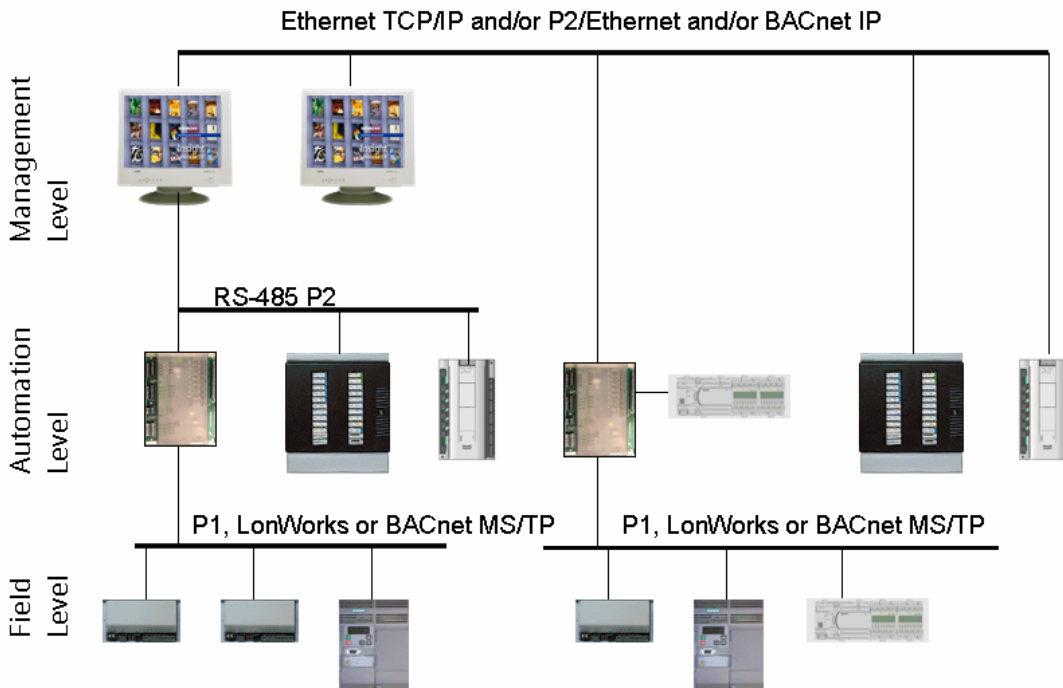

TX-I/O Bus Extension

The following picture shows the TX-I/O bus extended using a Bus Connection Module and TX-I/O Power Supply. The TX-I/O bus can be a maximum of 160 feet (50 meters) and may extend outside an enclosure.

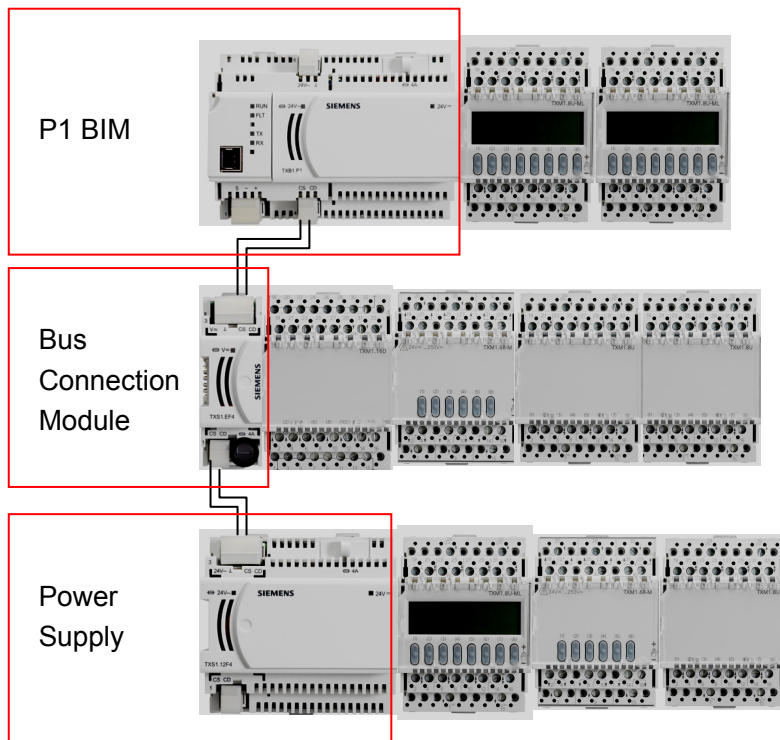

Technical Specifications:

Voltage requirements 24 Vac +/- 20% @ 50/60 Hz

Power Consumption

Power Supply 20 VA

P1 BIM 35 VA

With the above power consumption, the Power Supply produces 1.2A 24VDC (28.8 W) and the BIM provides 0.6A 24VDC (14.4 W) to be used by the following:

TXM1.8D 1.1 W

TXM1.16D 1.4 W

TXM1.8U 1.5 W

TXM1.8U-ML 1.8 W

TXM1.8X 2.2 W

TXM1.8X-ML 2.3 W

TXM1.6R 1.7 W

TXM1.6R-M 1.9 W

Terminations

I/O Terminals 20-12 AWG Solid

20-14 AWG Stranded

BIM and Power Supply 2 or 3 position screw terminal pluggable blocks

Operating Environment

+32°F to +122°F (0°C to 50°C)

5 to 95% rh (non-condensing)

Agency Listings

UL 864 UUKL

ULC-C100 UUKL7

UL 916 PAZX

CSA 22.2 No. 205 PAZX7

Agency Compliance

FCC Compliance

Australian EMC Framework (C-Tick)

European EMC Directive (CE)

European Low Voltage Directive (CE)

Dimensions

TX-I/O Modules: 2.52" (64 mm) L × 3.54" (90 mm) W × 2.75" (70 mm) D

TX-I/O BIM, P1 5" (128 mm) L × 3.54" (90 mm) W × 2.75" (70 mm) D

TX-I/O Power Supply 3.78" (96 mm) L × 3.54" (90 mm) W × 2.75" (70 mm) D

TX-I/O Bus Connection Module: 1.26" (32 mm) L × 3.54" (90 mm) W × 2.75" (70 mm) D

TX-I/O Ordering Information

Description	Product Number
TX-I/O Module, 8 DI points	TXM1.8D
TX-I/O Module, 16 DI points	TXM1.16D
TX-I/O Module, 8 Universal points	TXM1.8U
TX-I/O Module, 8 Universal points with LOID	TXM1.8U-ML
TX-I/O Module, 8 Super Universal points	TXM1.8X
TX-I/O Module, 8 Super Universal points with LOID	TXM1.8X-ML
TX-I/O Module, 6 DO with Relay points	TXM1.6R
TX-I/O Module, 6 DO with Relay points with manual override	TXM1.6R-M
TX-I/O Power Supply, 1.2 A, 4A Fuse	TXS1.12F4
TX-I/O Bus Connection Module, 4A Fuse	TXS1.EF4
TX-I/O Bus Interface Module, P1	TXB1.P1
2 sets, Address Keys 1-12	TXA1.K12
Address Keys 1-24	TXA1.K24
Address Keys 25-48	TXA1.K-48
Address Keys 49-72	TXA1.K-72
Labels for TX-I/O 100 sheets/pack Letter format	TXA1.LLT-P100
Replacement Label Holders	TXA1.LH

Regions where this Product is Sold (US, Asia Pacific, Canada, Latin America, UK)

Information in this document is based on specifications believed correct at the time of publication. The right is reserved to make changes as design improvements are introduced. APOGEE and Insight are registered trademarks of Siemens Building Technologies, Inc. Other product or company names mentioned herein may be the trademarks of their respective owners. © 2007 Siemens Building Technologies, Inc.

Room Temperature Sensors, Series 1000 and Standard Design and Semi-Flush Mount Series 2000 (Interactive)



Figure 1. Room Temperature Sensor--Series 1000 Shown with All Available Options.

The **Series 1000** and **Series 2000** Room Temperature Sensors from Siemens Building Technologies, Inc., offer a wide range of features and functionality that work in concert with the APOGEE® Automation System to deliver exceptional occupant comfort in even the most demanding application environments. The product family includes plain sensing-only variants, and fully interactive types with a two-line LCD that permits viewing and modifying controller points directly from the sensor's keypad and display as well as a semi-flush mount model (Series 2000). All sensors incorporate precision temperature sensing elements to accurately and reliably measure room temperature. Their compact, low profile design results in an attractive, inconspicuous installation. A styled ventilation ring optimizes airflow through the cover for fast measurement response and superior control.

Series 1000

The **Series 1000** Room Temperature Sensor provides accurate, reliable sensing of room temperature Terminal Equipment Controllers (TECs), Modular Building Controllers (MBCs), Remote Building Controllers (RBCs), Programmable Modular Controllers (PXC) and Modular Equipment Controllers (MECs).

TEC Applications

Room temperature sensors for TEC applications incorporate a thermistor element and plug-in Portable Operator's Terminal port located on the bottom of the cover. The plug-in Portable Operator's Terminal port provides a convenient means of communicating with the TEC to command or troubleshoot the system. These sensors connect to TECs via a six-wire cable terminated with a plug-in RJ-11 connector. The cable transmits the temperature, the communication with the Portable Operator's Terminal, and the optional setpoint and override signals.

MBC, RBC, PXC, and MEC Applications

Room temperature sensors for MBC, RBC, PXC and MEC applications incorporate a platinum RTD element. Connections to field panels are made via 18 to 22 AWG twisted pair cabling. A conveniently located unpluggable termination block simplifies both installation and service.

Optional Features

- **Digital temperature display:** The digital temperature display provides an easy-to-read room temperature value in degrees Fahrenheit or Celsius.
- **Setpoint adjustment:** The high accuracy setpoint adjustment incorporates dual temperature scale indication and an access door that covers the setpoint adjustment switch.
- **Override button:** The flush mounted override button allows an occupant to change to an occupied control schedule during the unoccupied cycle for a predetermined time period.
- **Maintenance free:** These sensors draw a small amount of power directly from the controller and do not use batteries. This eliminates the cost of battery replacement and disposal. Specifications (Series 1000)

Specifications (Series 1000)

Temperature Range	
Setpoint	55°F to 95°F (13°C to 35°C)
Operating	55°F to 95°F (13°C to 35°C)
Output Signals	Changing resistance
Sensing Element Type	
540 Models	10K NTC Thermistor (Type II)
544 Models	1K Platinum RTD (375 ALPHA)
Accuracy	
10K ohm Thermistor	
55 - 80.6°F (13 - 27°C)	±0.5°F (±0.3°C)
80.6 - 95°F (27 - 35°C)	±1.0°F (±0.5°C)
1,000 ohm RTD mid-range	
75°F (24°C)	±0.75°F (±0.4°C)
Calibration Adjustments	None required
Installation	
TEC	100 ft. Maximum cable length. 6C #24 AWG, Belden 1228A or equal, NEC Class 2
MBC/RBC/PXC/MEC	300 to 750 ft Max. cable length 18 to 22 AWG twisted pair NEC Class 2
Installation Adjustments	None required
Cover	
Dimensions	3-11/32" H x 2-1/2" W x 1-1/2" D (85 mm x 63 mm x 38 mm)
Color	Desert beige or white
Power Consumption ¹	8.6 mW maximum
544-7xx units	

¹ Power consumption values apply only to those units with single line display.



Figure 2. Room Temperature Sensor and Semi-Flush Mount Room Temperature Sensor--Series 2000.

Series 2000

The **Series 2000** Room Temperature Sensors provide an interactive digital link to Terminal Equipment Controllers (TECs) that allows viewing and adjusting controller points directly from the sensor's liquid crystal display and keypad. These sensors incorporate a precision thermistor to accurately and reliably measure room temperature.

NOTE: The Semi-Flush Mount Sensor can only be mounted in a 2 x 4 box without a gang riser/ring.

Standard Features

- **Programmable Liquid Crystal Display (LCD):** A two-line alphanumeric LCD allows simultaneous display of room temperature, a user-selected critical point, and day/night operation status. Users may configure the screen to:
 - show English or metric units,
 - turn the room temperature display on or off,
 - select a critical point for display, or
 - turn off the critical point display.
- **Digital setpoint adjustment:** The sensor's keypad allows error-free digital setpoint adjustments in one-degree increments. Setpoint values momentarily display as changes are made.
- **Display of operating mode:** Graphic symbols are displayed to indicate the controller's operating mode. A "sun" indicates occupied mode operation and a "moon" indicates night mode operation.
- **Override button:** A flush-mounted override button allows users to change to an occupied control schedule during the unoccupied cycle for a period of time determined by the system operator.

Standard Features, Continued

- Passkey security: A special hardware passkey plugs into the sensor's MMI port to allow access to the display configuration menu and the controller's point database.

NOTE: The Semi-Flush Mount Sensor MMI port can only be accessed after the front housing is removed.

- Backward compatibility: These sensors are backward compatible with all TECs. The sensors are wired with six-conductor phone cables and standard RJ-11 connectors.
- Maintenance free: These sensors draw a small amount of power directly from the controller and do not use batteries. This eliminates the cost of battery replacement and disposal.

Specifications (Series 2000)

Effective Sensing and Setpoint Range (TEC)	55°F to 95°F (13°C to 35°C)
Output Signals	Changing resistance
Room temperature	Changing resistance
Setpoint	Digital
Thermistor Calibration Point (TEC)	77°F (25°C)
Accuracy (10K ohm Thermistor)	
55 - 80.6°F (13 - 27°C)	±0.5°F (±0.3°C)
80.6 - 95°F (27 - 35°C)	±1.0°F (±0.55°C)
Resistance value	10K Ω ohms
Calibration	None required
Installation (TEC)	100 ft maximum cable length 6C #24 AWG, NEC Class 2
Installation Adjustments	None required
Dimensions	3-11/32" H x 2-1/2" W x 1-1/2" D (85 mm x 63 mm x 38 mm)
Color	Desert beige or white

Product Ordering Information

TEC Description	Product Part Number
Series 1000	
Sensing only	540-660 ¹
Sensing only, no logo	540-661 ¹
Sensing with override	540-662 ¹
Sensing with override, no logo	540-663 ¹
Sensing with setpoint	540-664 ¹
Sensing with temperature display	540-666 ²
Sensing with override and setpoint	540-670 ¹
Sensing with override and setpoint, no logo	540-671 ¹
Sensing with override and temperature display	540-672 ²
Sensing with setpoint and temperature display	540-676 ²
Sensing with override, setpoint and temperature display	540-680 ²
Series 2000	
TEC Sensor	540-650 ¹
Semi-Flush Mount Room Temperature Sensor, TEC	QAA1280.FWSC
MBC/RBC/PXC/MEC, Series 1000 Description	
Sensing only	544-760 ¹
Sensing with override	544-762 ¹
Sensing with setpoint	544-764 ¹
Sensing with temperature display	544-766 ²
Sensing with override, setpoint	544-770 ¹
Sensing with override, temperature display	544-772 ²
Sensing with setpoint, temperature display	544-776 ²
Sensing with override, setpoint, temperature display	544-780 ²

¹ Add letter suffix to indicate desired color: A=Desert Beige, B=White (for example, 540-660A).

² Add letter suffix to indicate temperature display units and color: F=°F, C=°C, A=Desert Beige, B=White (for example, 540-680FA).

Accessories Ordering Information

Description	Product Part Number
Occupancy Override Button, 25-pack (Beige)	544-480A
Occupancy Override Button, 25-pack (White)	544-480B
Setpoint Door, 25-pack (Beige)	544-481A
Setpoint Door, 25-pack (White)	544-481B
Blank Bezel, 25-pack (Beige)	544-482A
Blank Bezel, 25-pack (White)	544-482B
Room Temperature Sensor Repair Kit, Single-pack (Beige)	544-483A
Room Temperature Sensor Repair Kit, Single-pack (White)	544-483B
Blanking Override Button, 25-pack (Beige)	544-484A
Blanking Override Button, 25-pack (White)	544-484B
Passkey for Series 2000 Room Temperature Sensors	544-643
Single Adapter Base Kit (White)	544-782B
Single Adapter Base Kit (Beige)	544-782A
Double Adapter Base Kit (White)	544-783B
Double Adapter Base Kit (Beige)	544-783A
Extender Ring Kit (White)	544-785B
Extender Ring Kit (Beige)	544-785A
Non-Conduit Rough-In Kit	544-784
Series 2000 (Interactive) Room Temperature Sensors, User Guide	129-363
Sensor Power Supply Module (for MBC applications with digital display option)	PTX6.4SPS
Available with vinyl or plenum jacket in 25-foot, 50-foot and 100-foot lengths. Contact your local Siemens Building Technologies, Inc. field office for more information.	TEC room sensor cables (6 conductor w/RJ-11 connectors on each end)

Information in this document is based on specifications believed correct at the time of publication. The right is reserved to make changes as design improvements are introduced. APOGEE is a registered trademark of Siemens Building Technologies, Inc. Other product or company names mentioned herein may be the trademarks of their respective owners. © 2008 Siemens Building Technologies, Inc.

Analog Sensors—1000 Ω Platinum (375 α) RTD

Description

1000 Ohm Platinum (375 α) RTD sensors provide input for cost-effective, accurate temperature sensing (detecting) via a 20 AWG twisted, shielded cable pair. The sensor resistance varies according to the temperature being measured. Several models are available for specific mounting and sensing applications.



Figure 1. Surface Mounted Temperature Sensor.



Figure 2. Outside Air Temperature Sensor.



Figure 3. Duct (Single Point) Temperature Sensor (544-339-18 Shown with AQM2000 Accessory).



Figure 4. Duct (Averaging) Flexible Temperature Sensor.



Figure 5. Duct (Averaging) Rigid Temperature Sensor.

Specifications



Figure 6. Liquid Immersion Temperature Sensor.

Temperature Monitoring Ranges	See <i>Sensor Specifications</i>
Output Signal	Changing resistance
Elements	Platinum (or equivalent) wire resistance type
Accuracy	See <i>Sensor Specifications</i>
Reference Resistance at 32°F (0°C)	1000 Ohm

Sensor Specifications

Sensor Applications	Temperature Range (See Tolerance Formula at Bottom of Table)	Element Package	Part Number
Surface Mount - Pipe	-40°F to 240°F (-40°C to 116°C)	2-inch × 4-inch metal box with clamps	544-089
Outdoor Air		Through-the-wall	544-578
Duct - Single Point		4-inch (10 cm) 8-inch (20 cm) 18-inch (45 cm)	544-339-4 544-339-8 544-339-18
Duct - Averaging, Rigid	20°F to 120°F (-7°C to 49°C) Special Tolerances: 20°F ±2.3°F 70°F ±1.0°F 120°F ±2.8°F	18-inch (46 cm) 24-inch (60 cm) 36-inch (91 cm) 48-inch (122 cm)	544-343-18 544-343-24 544-343-36 544-343-48
Duct - Averaging, Flexible		8-foot (2.4 m) 16-foot (4.9 m) 24-foot (7.3 m)	544-342-8 544-342-16 544-342-24
Liquid Immersion	-40°F to 240°F (-40°C to 116°C)	2.5-inch (5 cm) 4-inch (10 cm) 6-inch (15 cm) Stainless steel wells NEMA 4/IP56 (immersion heads only)	544-577-25 544-577-40 544-577-60

Tolerance Formula: $\pm(0.54^{\circ}\text{F} + (0.005 \times |T_{\text{F}} - 32|)) [\pm(0.3^{\circ}\text{C} + (0.005 \times |T_{\text{C}}|))]$

where T_{F} (T_{C}) is the operating temperature point within the transmitter's range

(Example: For a sensor operating at 100°F; Tol = $\pm(0.54^{\circ}\text{F} + (0.005 \times |100^{\circ}\text{F} - 32^{\circ}\text{F}|))$ or $\pm 0.88^{\circ}\text{F}$)

Accessories

- AQM2000 Flange Gasket Kit (order separately if an adjustable depth is required for 544-339-18 duct point temperature sensors.)
- 544-577-RK Immersion Repair Kit

Information in this document is based on specifications believed correct at the time of publication. The right is reserved to make changes as design improvements are introduced. Other product or company names mentioned herein may be the trademarks of their respective owners.
© 2009 Siemens Building Technologies, Inc.

Hawkeye® High Amperage Split-Core Current Transducer

221/321/421 4-20mA Loop Powered Output

44



FIVE-YEAR
5
WARRANTY

IDEAL FOR INDUSTRIAL SIZE LOADS

The Hawkeye 221/321/421 analog current transducers provide reliable load trending information for large motor loads (up to 2400A) with a proportional 4–20mA signal. Each sensor can be calibrated for maximum resolution using the span potentiometer.

APPLICATIONS

- Load trending of large motors
- Split-core design is ideal for retrofit load trending

Monitor larger motors & other loads up to 2400A

- Split-core design for easy installation
- Eliminates need for external CTs on large conductors
- Large openings for heavy conductors
- Monitor critical motors (compressor, fuel, etc.)

Loop powered 4-20mA output

- Two-wire design reduces wiring cost
- Zero and span adjustment for easy setup and high resolution
- 5-year limited warranty

H221/321/421 LINEAR OUTPUT

Scale software as shown

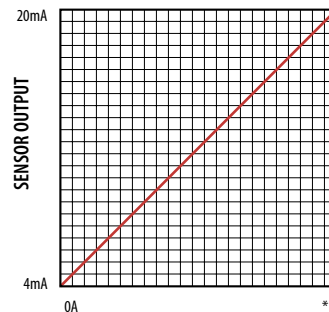

*Adjusted with Span Potentiometer

100 to 300A (H221)
300 to 800A (H321)
1000 to 2400A (H421)



ORDERING INFORMATION

MODEL	AMPERAGE RANGE		OUTPUT TYPE	UL
	4mA	20mA (SPAN)		
H221	0A	100 to 300A	4-20mA	●
H321	0A	300 to 800A	4-20mA	●
H421	0A	1000 to 2400A	4-20mA	

Factory calibration available upon request



ACCESSORIES

MODEL	DESCRIPTION
PS-24 Series	Universal Power Supply
AH06	Universal Mounting Bracket Kit

APPLICATIONS/WIRING EXAMPLE

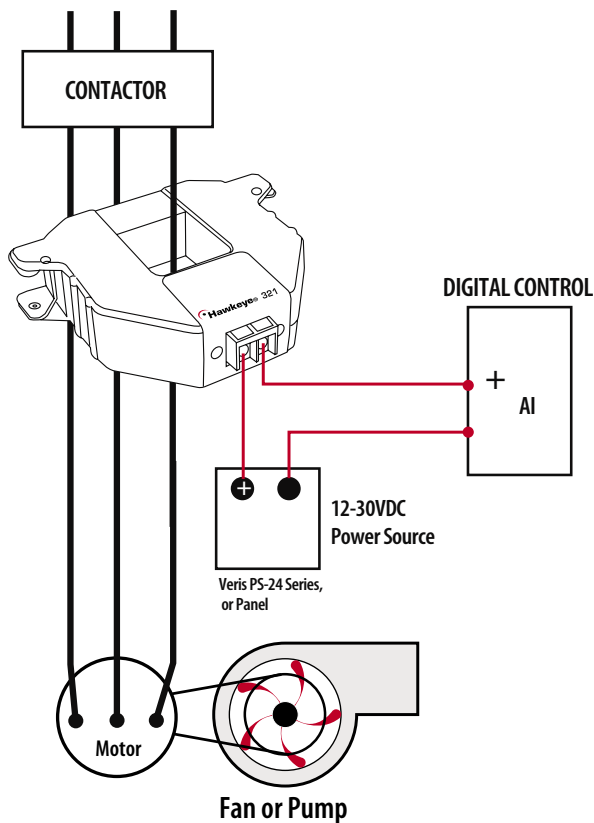

DIMENSIONAL DRAWINGS

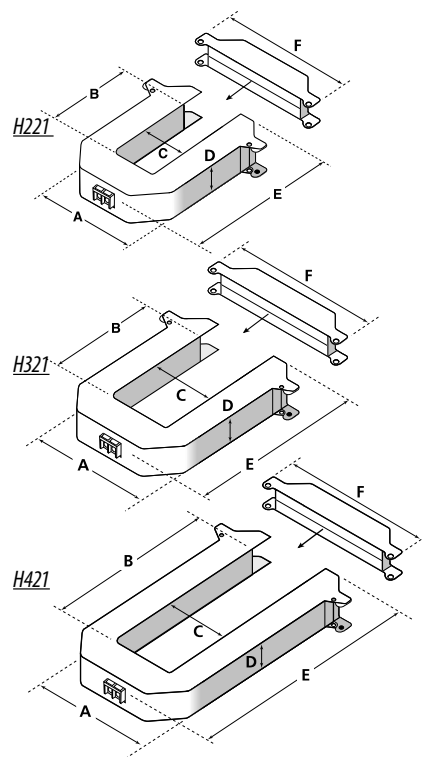

SPECIFICATIONS

Amperage Range:	
Model 221	0-300A (potentiometer scalable)
Model 321	0-800A (potentiometer scalable)
Model 421	0-2400A (potentiometer scalable)
Output	4-20mA
Insulation Class	600VAC rms
Frequency Range	60Hz nominal
Temperature Range	-15° to 60°C
Humidity Range	0 - 95% non-condensing
Accuracy	2%
Response Time	2 sec.
Supply Voltage	12 to 30VDC
Supply Current	30mA max.
Zero Adjustment	3.5 to 4.5mA

H221

A = 3.75" (95 mm)
B = 1.51" (38 mm)
C = 1.25" (32 mm)
D = 1.13" (29 mm)
E = 4.20" (107 mm)
F = 4.75" (121 mm)

H321

A = 4.90" (124 mm)
B = 2.89" (73 mm)
C = 2.45" (62 mm)
D = 1.13" (29 mm)
E = 5.57" (141 mm)
F = 5.91" (150 mm)

H421

A = 4.90" (124 mm)
B = 5.50" (140 mm)
C = 2.45" (62 mm)
D = 1.13" (29 mm)
E = 8.13" (207 mm)
F = 5.92" (150 mm)

Model 230

Wet/Wet Pressure Transducer



Setra Systems Model 230 is a high output, low differential pressure transducer designed for wet to wet differential pressure measurements of liquids or gases. A fast-response capacitance sensor and signal conditioned electronic circuitry provide a highly accurate, linear analog output proportional to pressure. Both unidirectional and bidirectional pressure ranges are available for applications with line pressure up to 250 psig.

A unique isolation system transmits the motion of the differential pressure sensing diaphragm from the high line pressure environment (e.g. corrosive liquids) to the dry (air) enclosure where it moves one of a pair of capacitance plates proportionally to the diaphragm movement. All parts exposed to the pressure media are stainless steel and elastomer seals. The 230 has a NEMA 4/IP65 rated package to withstand environmental effects. This system responds to pressure changes approximately 20 times faster than conventional fluid-filled transducers. The electronic circuit linearizes output vs. pressure and compensates for thermal effects of the sensor.



3-VALVE MANIFOLD

The Model 230 can be supplied with an optional 3-valve manifold assembly for ease of installation and maintenance. The 3-valve manifold is a machined brass body requiring no internal pipe connections, thereby, eliminating the risk of internal leaks. The manifold's rugged, yet compact, construction requires minimum space for installation and use. The 230 bleed ports allow for total elimination of air in the line and pressure cavities. If the Model 230 is ordered with the 3-valve manifold, the system is shipped completely assembled and ready for wall or pipe mounting. (Order as Pressure Fitting Code 3V.)



Visit Setra Online:
<http://www.setra.com>

New!

Optional 3-Valve Manifold Assembly

setra

800-257-3872

Model 230 Specifications

Performance Data

Accuracy RSS* (at constant temp)	±0.25% FS
Non-Linearity, BFSL	±0.20% FS
Hysteresis	0.10% FS
Non-Repeatability	0.05% FS
Thermal Effects**	
Compensated Range °F(°C)	+30 to +150 (-1 to +65)
Zero shift %FS/100°F(%FS/50°C)	2.0 (1.8)
Span Shift %FS/100°F(%FS/50°C)	2.0 (1.8)
Line Pressure Effect	Zero shift ±0.004%
	FS/psig line pressure
Resolution	Infinite, limited only by output noise level (0.02%FS)
Static Acceleration Effect	2%FS/g (most sensitive axis)
Natural Frequency	500 Hz (gaseous media)
Warm-up Shift	±0.1% FS total
Response Time	30 to 50 milliseconds
Long Term Stability	0.5%FS/1 YR
Maximum Working Pressure	250 psig

*RSS of Non-Linearity, Non-Repeatability and Hysteresis.

**Units calibrated at nominal 70°F. Maximum thermal error computed from this datum

Environmental Data

Temperature	
Operating °F (°C)	0 to +175 (-18 to +80)
Storage °F (°C)	-65 to +250 (-54 to +121)
Vibration	5 g from 5 Hz to 500 Hz
Acceleration	10 g
Shock	50 g

*Operating temperature limits of the electronics only.

Pressure media temperatures may be considerably higher or lower.

Physical Description (Model 230)

Case	Stainless Steel/Aluminum
Electrical Connection	Barrier strip terminal block with conduit enclosure & 0.875 DIA conduit opening.
Pressure Fittings	1/4" -18 NPT internal
Weight (approx.)	14.4 oz
Sensor Cavity Volume	0.27 in ³ Positive Port, 0.08 in ³ Negative Port
(With 1/4"NPT external fittings installed - does not include cavity volume of 1/4"NPT external fittings.)	

Specifications are subject to change without notice.

Physical Description

(3-Valve Manifold Assembly)

Manifold Block	Brass
Valves (3)*	V1 for connection to + port V2 for connection to - port V3 for equalizing pressure
Valve Type	90° On/Off
Process Connections	1/4" -18 NPT Internal Thread
Dimensions	7.05"W x 6.25"H x 2.16"D
Weight	<2.5 lbs.

*Refer to drawing on back page.

Electrical Data (Current)

Circuit	2-Wire
Output*	4 to 20 mA**
External Load	0 to 1000 ohms
Minimum loop supply voltage (VDC)	= 9 + 0.02 x (Resistance of receiver plus line).
Maximum loop supply voltage (VDC)	= 30 + 0.004 x (Resistance of receiver plus line).

*Calibrated at factory with a 24VDC loop supply voltage and a 250 ohm load.

**Zero output factory set to within 4mA (±0.08mA)

**Span output factory set to within 20mA (±0.08mA)

Pressure Media

For the Model 230

Gases or liquids compatible with 17-4 PH Stainless Steel, 300 Series Stainless Steel, Viton and Silicone O-Rings.

Note: Hydrogen not recommended for use with 17-4 PH stainless steel.

Optional Buna-N O-rings are recommended for hydrocarbon applications.

For the 3 Valve Manifold

Gases or liquids compatible with 360 brass, Copper 122, Acetal plug valves and Nitrile O-rings.

Applications

- Energy Management Systems
- Process Control Systems
- Flow Measurement of Various Gases or Liquids
- Liquid Level Measurement of Pressurized Vessels
- Pressure Drop Across Filters

Features

- NEMA 4/IP65 Rating
- No Liquid Fill Diaphragm
- Available with 3-Valve Manifold Assembly Option
- Low Line Pressure Effect
- Low Cost
- Fast Response
- Gas and Liquid Compatible
- Low Differential Ranges

When it comes to a product to rely on - choose the Model 230. When it comes to a company to trust - choose Setra.

Pressure Ranges

UNIDIRECTIONAL		
Pressure Range PSID	Proof Pressure High Side* PSI	Proof Pressure Low Side* PSI
0 to 1	20	2.5
0 to 2	40	5
0 to 5	100	12.5
0 to 10	100	25
0 to 25	250	62.5
0 to 50	250	125
0 to 100	250	250

BIDIRECTIONAL		
Pressure Range PSID	Proof Pressure High Side* PSI	Proof Pressure Low Side* PSI
0 to ±0.5	20	1.25
0 to ±1	40	2.5
0 to ±2.5	100	6.25
0 to ±5	100	12.5
0 to ±10	200	25
0 to ±25	250	62.5
0 to ±50	250	125

*The zero will shift slightly when high differential overpressure is applied. The shift may be as much as ±10% FS with overpressure applied to the low pressure port. Other parameters (sensitivity, linearity, etc) will not shift. If the overpressure is normally only in one direction, the user may apply this overpressure to preset the sensor. Subsequent overload of less magnitude will not cause additional shift. The unit is pre-zeroed at the factory after application of maximum overload pressure to the high pressure port.

NOTE: Setra quality standards including ISO 9001 are based on ANSI-Z540-1. The calibration of this product is NIST traceable. U.S. Patent nos. 4054833



Visit Setra Online:
<http://www.setra.com>

setra
800-257-3872

Outline Drawings – Model 230 Transducer

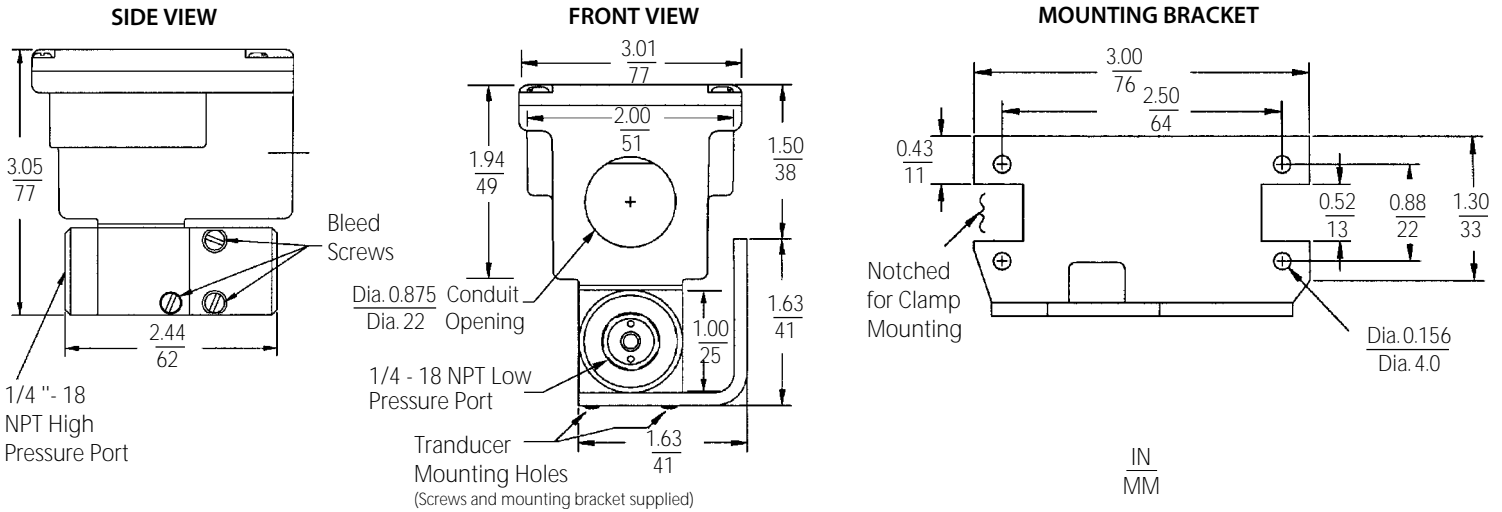

Outline Drawing – Model 230 Transducer with 3-Valve Manifold Assembly

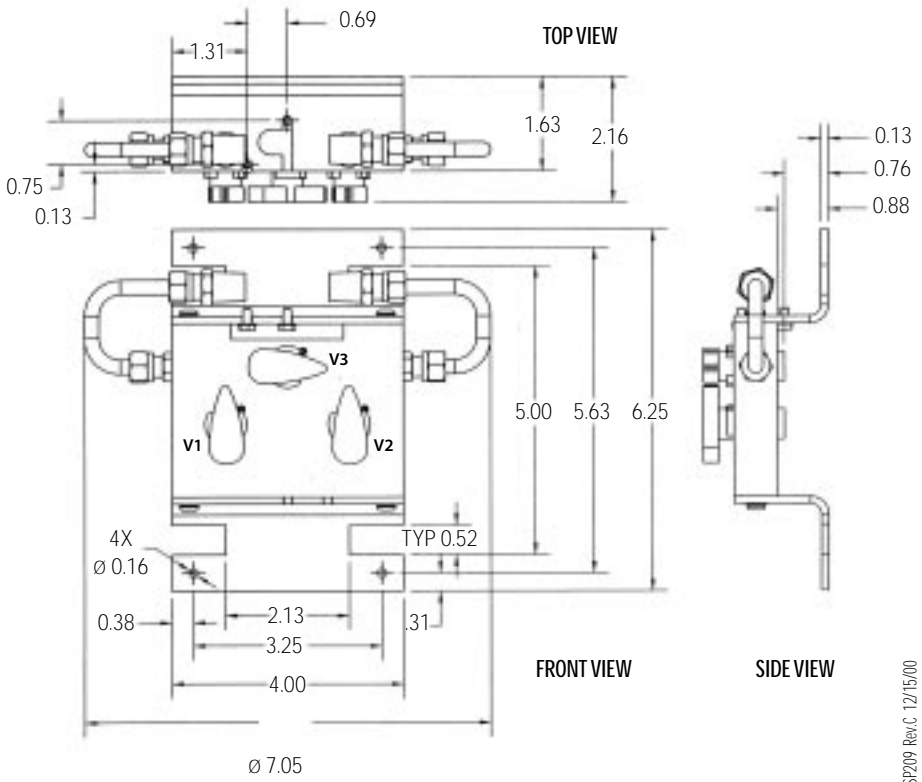
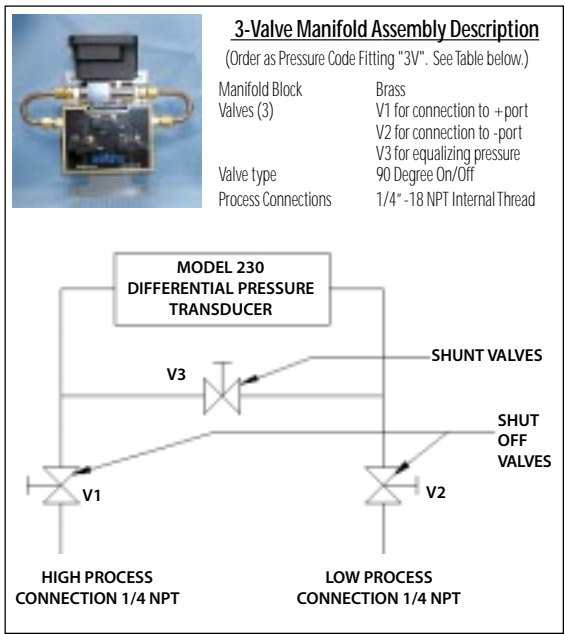

ORDERING INFORMATION

Model 230 Pressure Transducer				Model 230 with 3 Valve Manifold			
UNIDIRECTIONAL PSID	Product Code	BIDIRECTIONAL PSID	Product Code	UNIDIRECTIONAL PSID	Product Code	BIDIRECTIONAL PSID	Product Code
0 to 1	2301001PD2F11B	-0.5 to +0.5	23010R5PB2F11B	0 to 1	2301001PD3V11B	-0.5 to +0.5	23010R5PB3V11B
0 to 2	2301002PD2F11B	-1 to +1	2301001PB2F11B	0 to 2	2301002PD3V11B	-1 to +1	2301001PB3V11B
0 to 5	2301005PD2F11B	-2.5 to +2.5	23012R5PB2F11B	0 to 5	2301005PD3V11B	-2.5 to +2.5	23012R5PB3V11B
0 to 10	2301010PD2F11B	-5 to +5	2301005PB2F11B	0 to 10	2301010PD3V11B	-5 to +5	2301005PB3V11B
0 to 25	2301025PD2F11B	-10 to +10	2301010PB2F11B	0 to 25	2301025PD3V11B	-10 to +10	2301010PB3V11B
0 to 50	2301050PD2F11B	-25 to +25	2301025PB2F11B	0 to 50	2301050PD3V11B	-25 to +25	2301025PB3V11B
0 to 100	2301100PD2F11B	-50 to +50	2301050PB2F11B	0 to 100	2301100PD3V11B	-50 to +50	2301050PB3V11B

Please contact factory for versions not shown.

While we provide application assistance on all Setra products, both personally and through our literature, it is up to the customer to determine the suitability of the product in the application.

159 Swanson Road, Boxborough, Massachusetts 01719/Tel: 800-257-3872;
 Fax: 978-264-0292; Email: sales@setra.com; Web: www.setra.com



SSP209 Rev.C 12/15/00

Q-Series Room Relative Humidity and Relative Humidity & Temperature Sensors



Figure 1. Q-Series Room Relative Humidity and Relative Humidity & Temperature Sensor.



Figure 2. Q-Series Room Relative Humidity and Relative Humidity & Temperature Sensor.

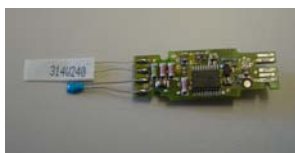

Figure 3. Q-Series Relative Humidity Removable Sensing Element (Replacement Part AQF3050).

Description

The Q-Series Room Relative Humidity and Relative Humidity & Temperature Sensors monitor and transmit changes in humidity and temperature to the building control systems. These units are especially suited for applications where precise, stable humidity sensing is required.

The new Q-Series sensors utilize the same housing as their Series 1000 predecessors, but with a totally new internal circuit design and sensing element.

Several models are available: humidity only versions (with $\pm 5\%$ or $\pm 2\%$ accuracy) and humidity and temperature sensing versions (also with $\pm 5\%$ or $\pm 2\%$ accuracy).

The humidity only units have either a 4 to 20 mA or 0 to 10 Vdc output signal.

The combination humidity and temperature units have a current or voltage humidity output, with the temperature output being a matching current or voltage signal, or a passive nickel, platinum, or NTC Sensing Element.

Sensing models (with display or full-featured) are also available. The full-featured models offer a wide range of features and functionality that can be used with a variety of building control systems:

Liquid Crystal Display (LCD): A 2-line alpha numeric LCD allows simultaneous display of room temperature and relative humidity in degrees Fahrenheit or Celsius.

NOTE: Sensing models with display (QFAxxxx.Dxxx) show degrees Fahrenheit only. To show degrees Celsius, order the full-featured model (QFAxxxx.Fxxx).

Digital Temperature Setpoint Adjustment: The sensor's keypad allows error-free digital temperature setpoint adjustments in 0.5°F (0.2°C) increments. Setpoint values momentarily display as adjustments are made.

Override Button: Allows an occupant to change to an unoccupied control schedule during the unoccupied cycle for a predetermined time period.

All 2% versions allow the sensing element to be removed and replaced if needed. Siemens sensors with replaceable elements are ideal for applications where measurement accuracy is critical and sensor replacement is not an option. Replaceable sensing elements eliminate the need for accuracy adjustment.

Specifications – Humidity Output

Measurement range	0 to 100% rh
Accuracy of 5% rated sensors at room temperature (73°F, 20°C)	±5% rh for 0% ≤ rh <30% or 70% ≤ rh <95% ±3% rh for 30% ≤ rh <70%
Accuracy of 2% rated sensors at room temperature (73°F, 20°C)	±2% 0% to 100% rh
Temperature effect	Less than 0.1% per degree C
Sensing element	Capacitive humidity sensing element
Output signal	4 to 20 mA or 0 to 10 Vdc, 0 to 100% linear, proportional
Polarity protection	Yes

Specifications–Temperature Output (for combination RH/T units only)

Temperature setpoint output range	63°F to 83°F (17°C to 28°C)
Setpoint output signal:	0 to 10 Vdc, 0 to 100% linear, proportional
Time constant at 0 to 50°C and 10 to 80% rh	Approx. 20 seconds in moving air
Accuracy	±1°C
Output signal	Active: 4 to 20 mA or 0 to 10 Vdc or Passive: Platinum 1000 Ohm RTD
Calibration adjustments	None

General Specifications

Operating conditions	
Relative humidity	0 to 100%
Temperature	32°F to 122°F (0°C to 50°C)
Installation	18 AWG cable length shared in conduit with other sensor wiring 750 ft (229 m) maximum
Connections	Screw terminals
Housing Dimensions	3-11/32" H × 2-1/2" W × 1-1/2" D (85 mm × 63 mm × 38 mm)
Voltage requirement	
0 to 10 Vdc output types	13.5 to 35 Vdc or 24 Vac
4 to 20 mA output types	13.5 to 35 Vdc
Material Type	Polycarbonate plastic
Color	Desert beige or white
CE and UL-listed	UL 873 standard for temperature indicating and regulating equipment

Ordering Information

			Q	F	A	x	0	x	x	.	x	x	x	U
TYPE	SENSOR	Q												
MEASURING UNIT	HUMIDITY	F												
APPLICATION/LOCATION	ROOM	A												
SENSOR ACCURACY	STANDARD 5%	2												
	HIGH ACCURACY 2%	3												
HOUSING TYPE	SERIES 1000 HOUSING	0												
TEMPERATURE OUTPUT SIGNAL	NONE	0												
	PLATINUM 1000 OHM (385 ALPHA)	1												
	ACTIVE VOLTAGE (0 TO 10 VOLT)	6												
	ACTIVE CURRENT (4 TO 20 MA)	7												
HUMIDITY SIGNAL	0 TO 10 VOLT	0												
	4 TO 20 MA	1												
SEPARATOR		.												
FEATURE DESCRIPTION - FOR ROOM	SENSING ONLY	-												
	DISPLAY ONLY	D												
	FULL-FEATURED (DISPLAY, SETPT AND OVERRIDE)	F												
COLOR	WHITE	W												
	BEIGE	B												
LOGO	SIEMENS LOGO	-												
	NO LOGO	N												
US VERSION	UNIVERSAL	U												

NOTE: For combination RH&T versions, mixed 4 to 20 mA and 0 to 10V signals are not offered.

Part Number	Description
Example: QFA2060.WNU	Sensor, RH Room, 5%, 0 to 10V Temp, 0 to 10V RH, Sensing Only, White, No Logo
Accessory Part Numbers	Description
544-782B	Single Adapter Base Kit (White)
544-782A	Single Adapter Base Kit (Beige)
544-783B	Double Adapter Base Kit (White)
544-783A	Double Adapter Base Kit (Beige)
544-785B	Extender Ring Kit (White)
544-785A	Extender Ring Kit (Beige)
544-784	Non-Conduit Rough-In Kit
AQF3050	Replaceable Sensing Element (2% versions only)

Information in this document is based on specifications believed correct at the time of publication. The right is reserved to make changes as design improvements are introduced. © 2007 Siemens Building Technologies, Inc.