

REV	CHANGE DESCRIPTION	ECN	DATE	REVISED BY	APPROVED BY

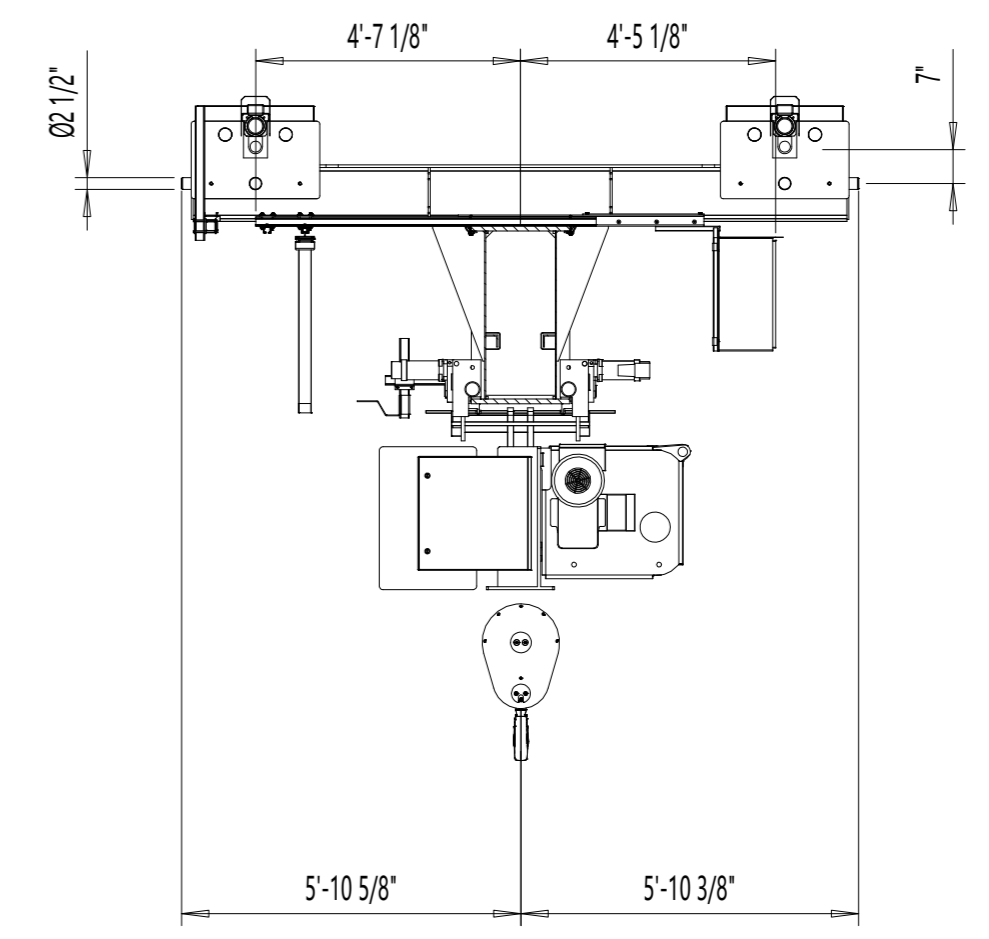

View A-A

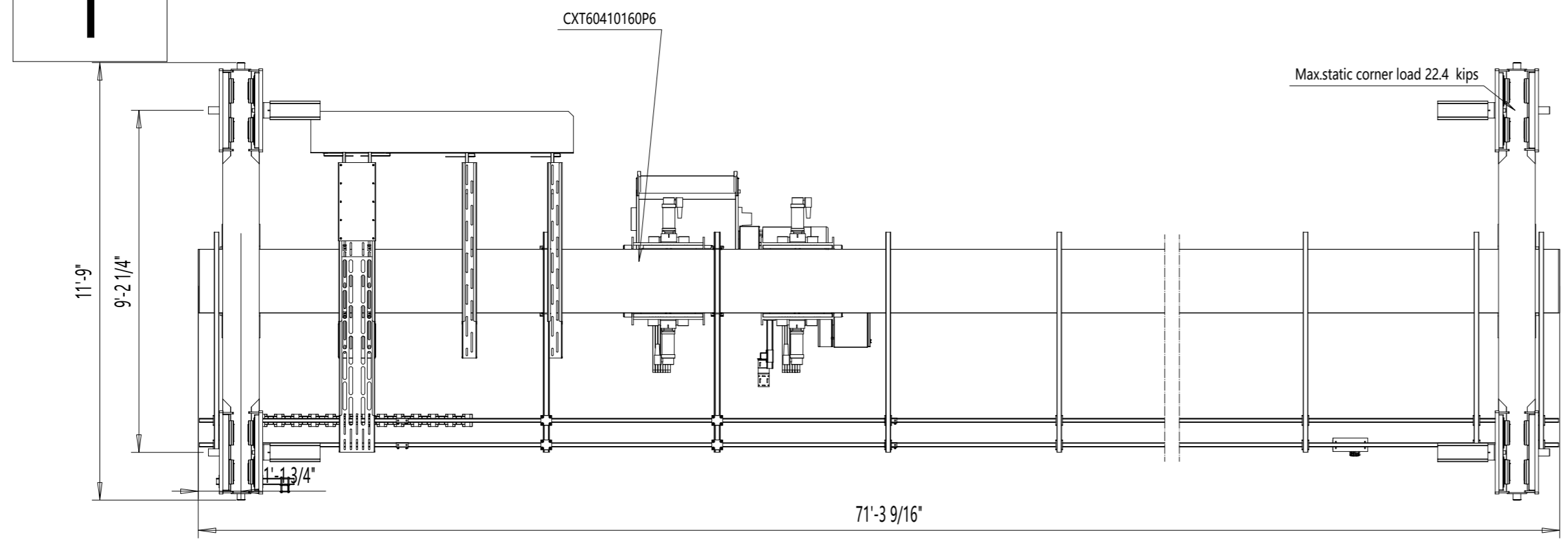
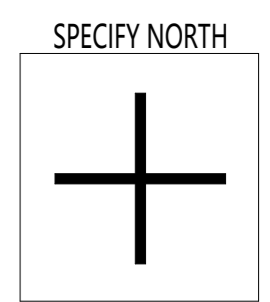

TECHNICAL DATA

Span	: 69'-0"
Load	: 15-TON
Lifting height	: 52'-0"
Hoisting speed	: 20.0/3.2 ft/min 2-speed
Traversing speed	: 80/20 ft/min 2-speed inverter
Travelling speed	: 65 ft/min Stepless
Weight of trolley	: 5550 lbs
Weight of bridge	: 20866 lbs
Crane classification	: CMAA Class C
Power supply	: 460 / 115 V; 60 Hz

SURFACE TREATMENT OF CRANE

Bridge color	: RAL1028
Paint	: ENA/127 µm
Access to crane and certain maintenance items is via man lift	
Outdoor Use crane 14° 104° F	
Pendant controlled crane: movable	

ACCEPTED BY:

COMPANY:

DATE:

Pos	Amount	Description	Specification
	KSA/PRG		DAS / 2.146.15
	Design	Chd	Vx proj
	04/19	Appd	
	Date	Ref drawing	
	Markman Support		
	Dept		
	KONECRANES		
	Konecranes, Inc.		
		CXTU15-TON x 69ft HoI:52.01ft	1:40
			M-film
			Issue
		OFFER-357350 Crane 1 Standard-O	

This document is the absolute property of Konecranes, Inc. This document must not be copied without the written permission of Konecranes, Inc. or its parent company, KONECRANES. The contents thereof must not be disclosed to a third party nor be used for any unauthorized purpose. Contravention will be prosecuted.

OFFER-357350 Crane 1 Standard-OI

REV	CHANGE DESCRIPTION	ECN	DATE	REVISED BY	APPROVED BY
-----	--------------------	-----	------	------------	-------------

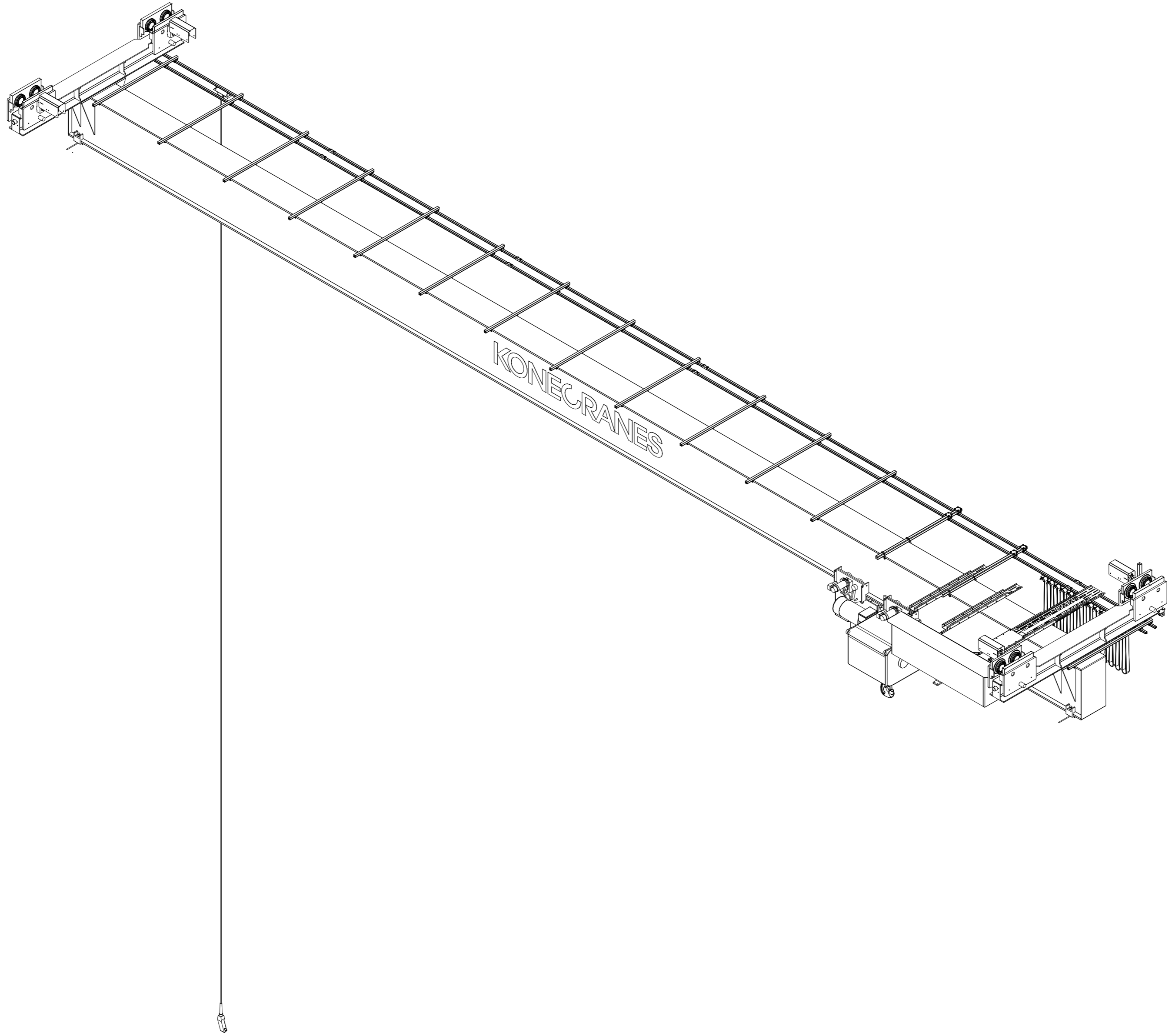

This document is the absolute property of Konecranes, Inc. This document must not be copied without the written permission of Konecranes, Inc. or its parent company KONECRANES. The contents thereof must not be disclosed to a third party nor be used for any unauthorized purpose. Contravention will be prosecuted.

Pos	Amount	Description	Specification
	KSA/PRG		DAS / 2.146.15
	Design	Chd	Appd
	04/19		Ref drawing
	Date		Vx proj
	Markman Support		
	Dept		
	KONECRANES		
	Konecranes, Inc.		
		CXTU15-TON x 69ft HoI:52.01ft	1:40
			M-film
			Issue
		OFFER-357350 Crane 1 Standard-OI	