

This document, together with the concepts and designs presented herein, as an instrument of service, is intended only for the specific purpose and client for which it was prepared. Reuse of and improper reliance on this document without written authorization and adaptation by Kimley-Horn and Associates, Inc. shall be without liability to Kimley-Horn and Associates, Inc.

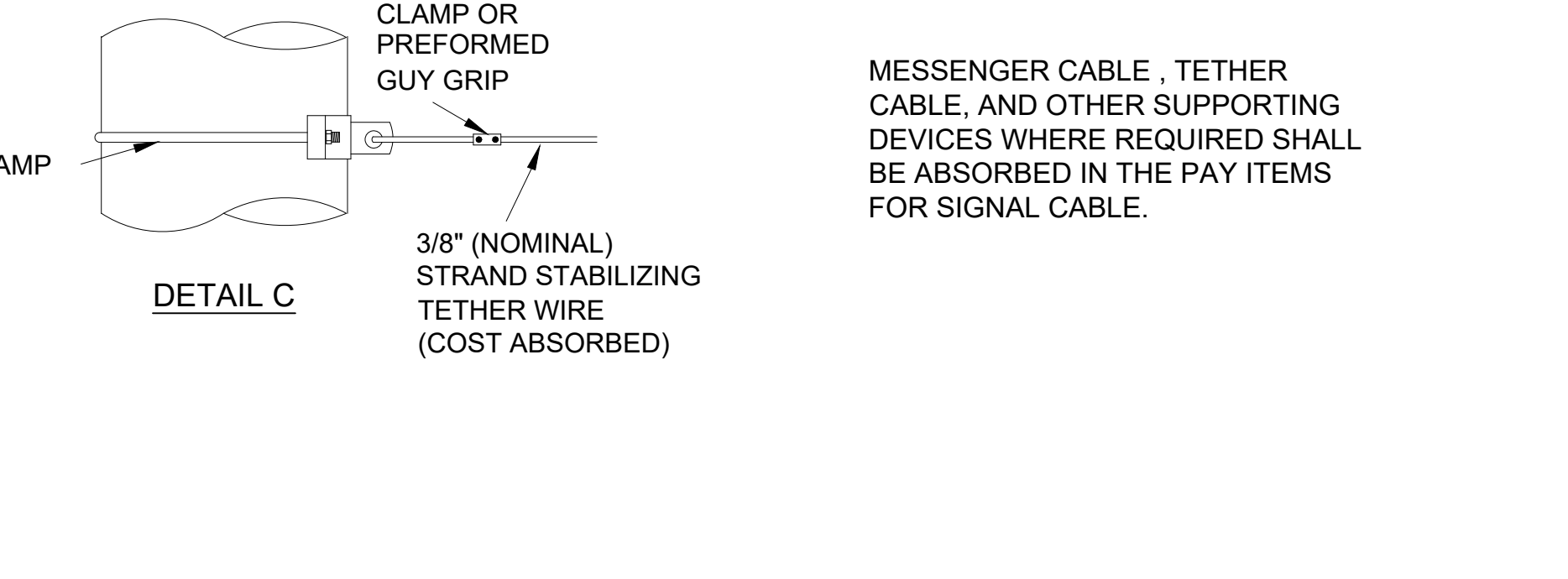

NO.	REVISIONS	DATE	BY

Kimley»Horn
 420 N 20TH ST, SHIPT TOWER STE 2200, BIRMINGHAM, AL 35203
 PHONE: 205-558-5831
 WWW.KIMLEY-HORN.COM

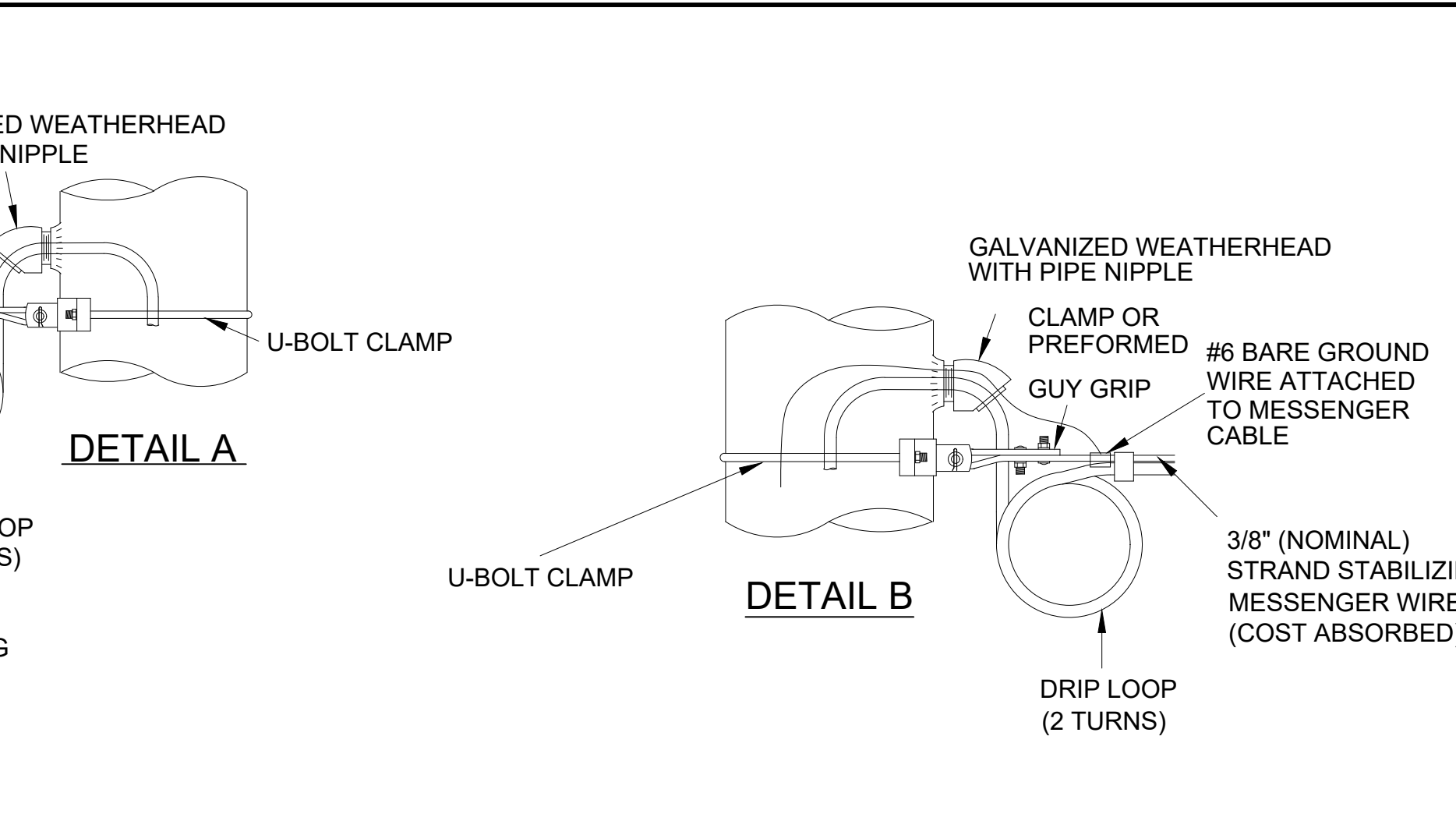
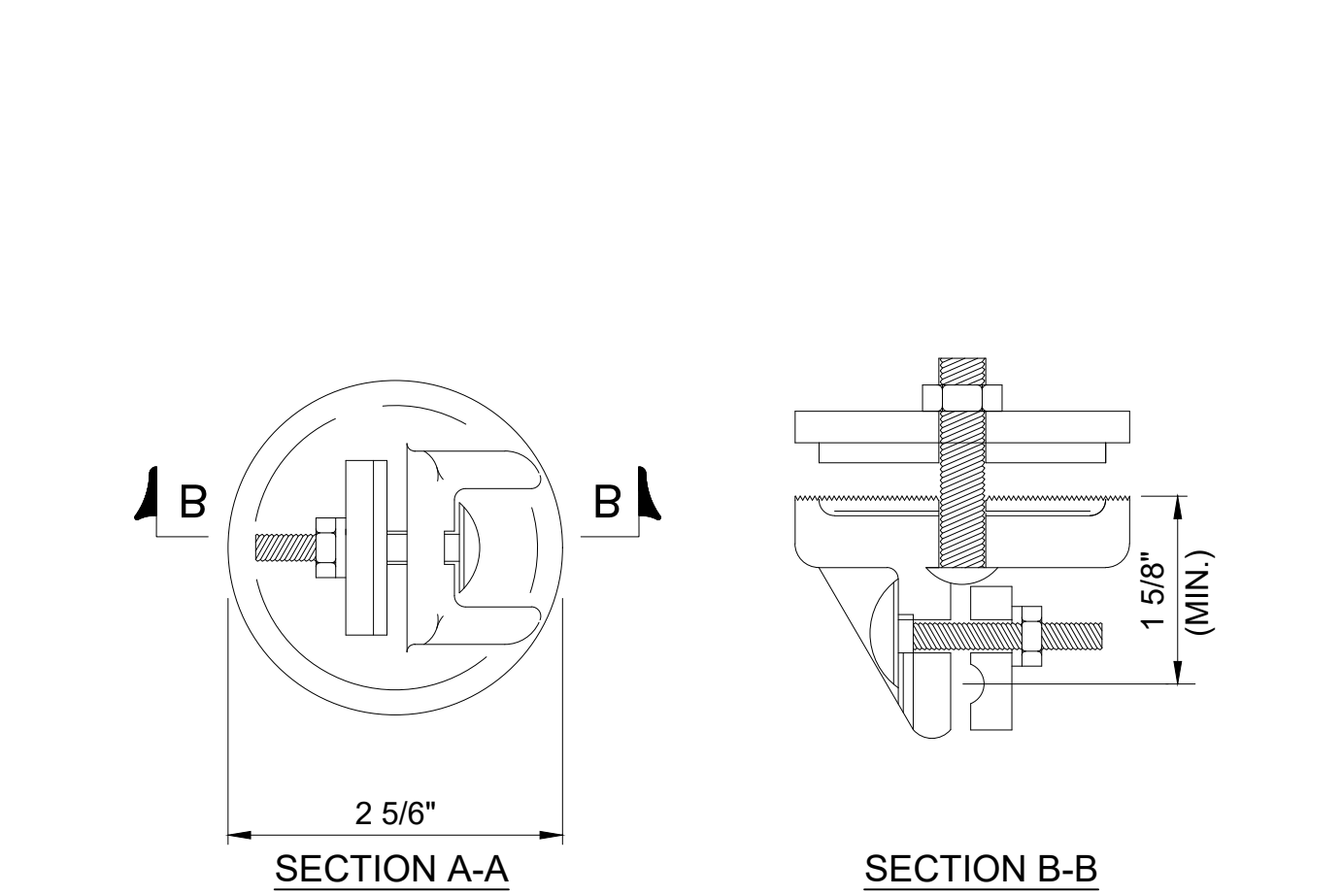
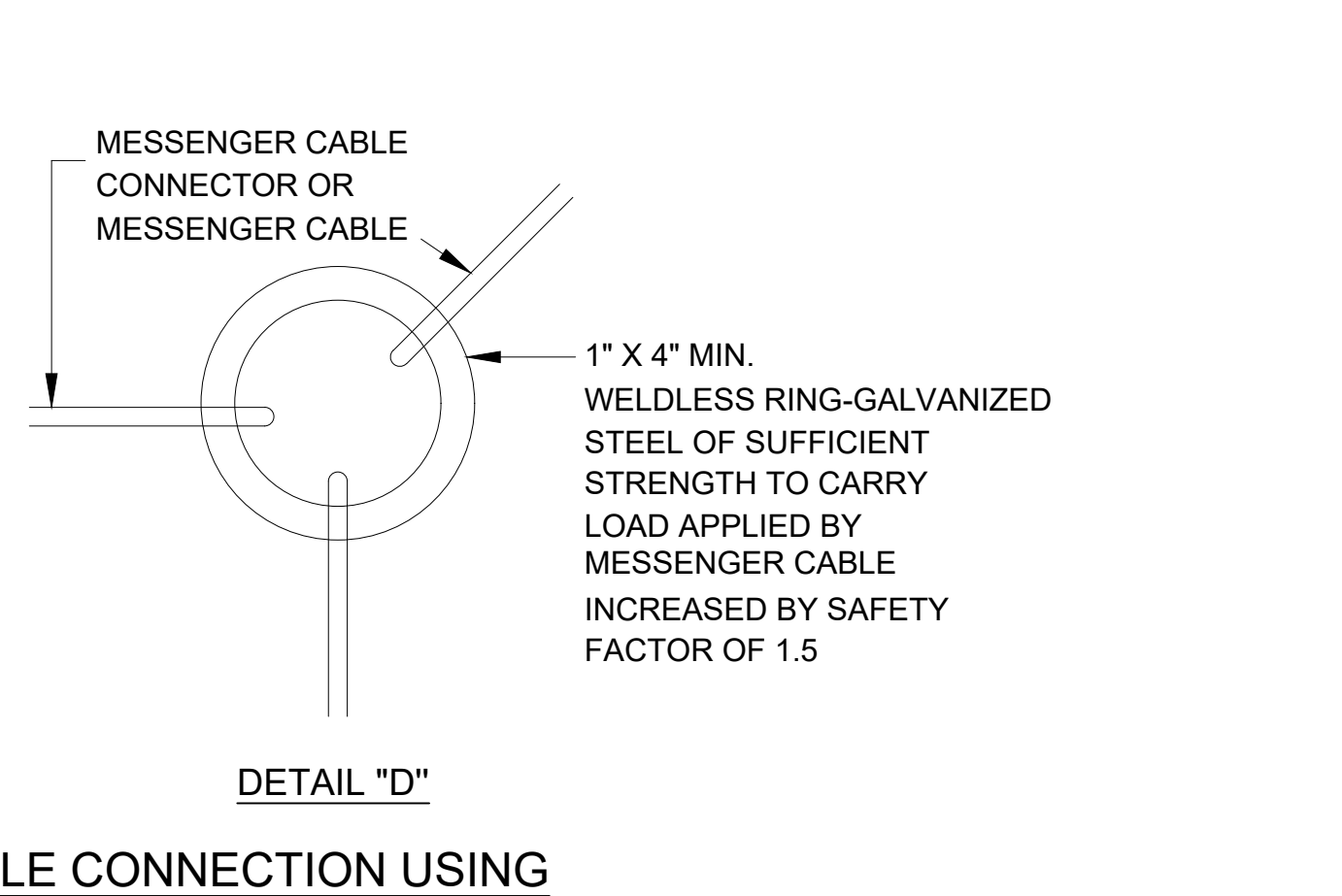
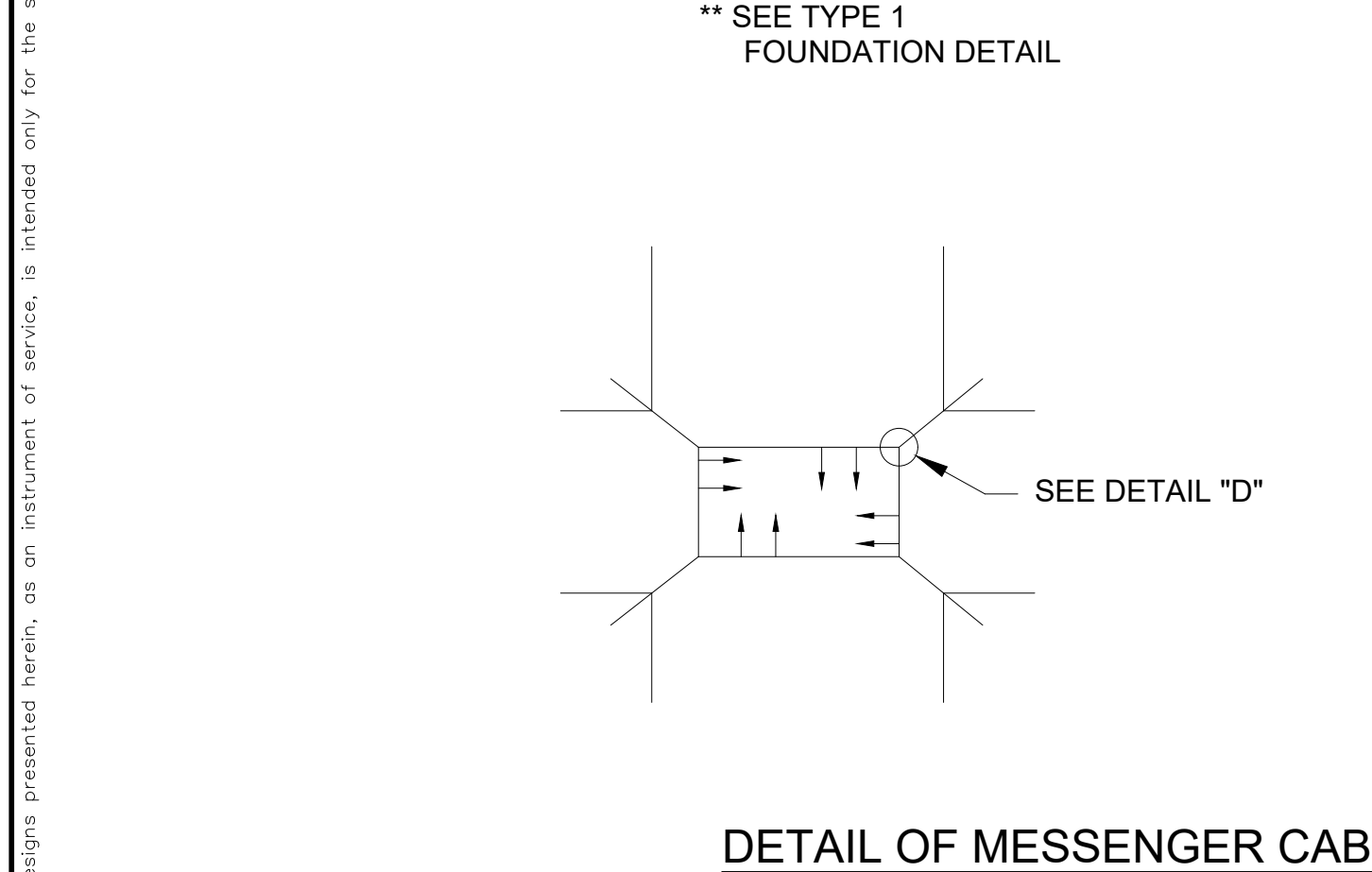
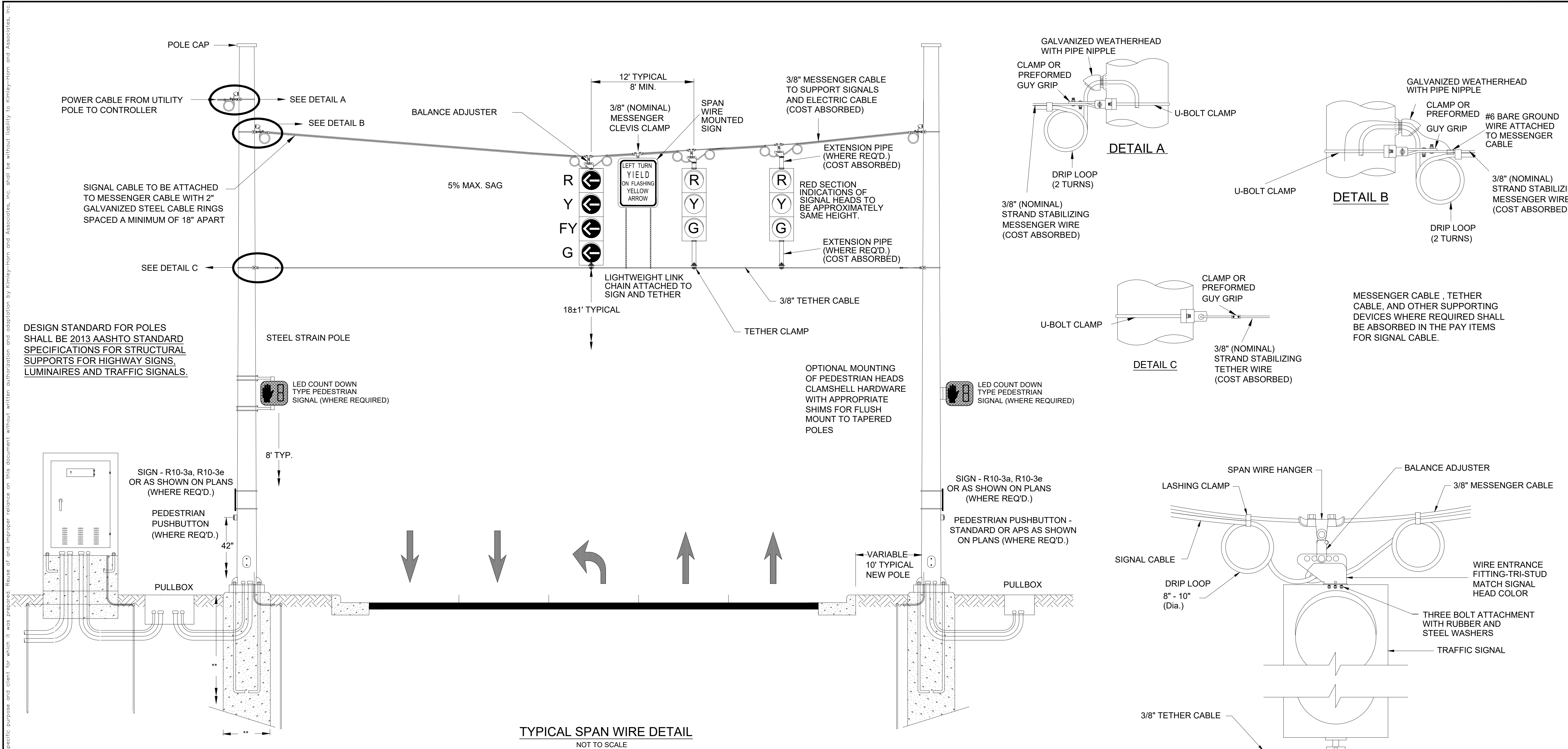
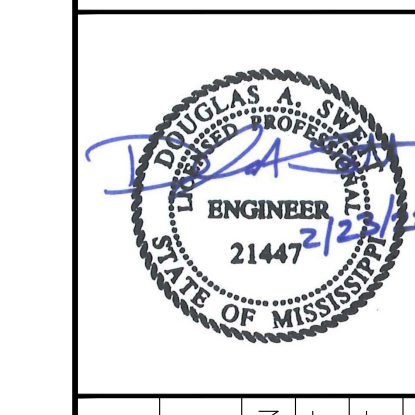

KHA PROJECT 142362033	DATE 2/2022	SCALE AS SHOWN	DESIGNED BY BST	DRAWN BY BST	CHECKED BY CBB
--------------------------	----------------	-------------------	--------------------	-----------------	-------------------

SPAN WIRE DETAILS

LOVE'S TRAVEL STOP
 TRAFFIC SIGNAL DESIGN
 PREPARED FOR
MDOT

PICAYUNE MS

SHEET NUMBER
TS7