



DAMMON ENGINEERING, INC.
EMMETT DAMMON

ARCHITECT
ROBERT SOLBERGER
1095 FLORIDA AVENUE
SLIDELL, LA, 70458
985-649-5832

WEBSITE:
WWW.DAMMONENGINEERING.CO
EMAIL:
DAMMONENG@BELLSOUTH.NET

ARCHITECTURE
ENGINEERING
STUDIES
PLANNING
INVESTIGATION
EXPERT WITNESS

NEW OFFICE/ WAREHOUSE BUILDING

REINE CONSTRUCTION
OLD MILITARY RD.
PEARL RIVER, LA

SITE PLAN

AREA BY USE
TOTAL OFFICE SQ.FT. = 2200
TOTAL WAREHOUSE SQ.FT. = 2800
TOTAL BUILDING SQ.FT. = 5000

PARKING REQUIREMENTS
5,000 SQ. FT. TOTAL OFFICE / WAREHOUSE BUILDING AREA
REQUIRES: 1 PARKING SPACE / 300 SQ. FT. OF OFFICE BUILDING AREA
TOTAL PARKING REQUIRED = 16 SPACES (1 HOP)
TOTAL PARKING PROVIDED = 16 SPACES (1 HOP)

SITE LIGHTING
EXTERIOR LIGHTING SHALL BE SHADED OR INWARDLY DIRECTED IN SUCH A MANNER SO THAT NO DIRECT LIGHTING OR GLARE BE CAST BEYOND THE PROPERTY LINE. THE INTENSITY OF SUCH LIGHTING SHALL NOT EXCEED ONE FOOT CANDLE AS MEASURED AT THE ABUTTING PROPERTY LINE.

LANDSCAPING REQUIREMENTS
PARKING AREA: PER PEARL RIVER ORDINANCE #01-00: TWO CLASS 'B' TREES SHALL BE PROVIDED FOR EVERY EIGHT PARKING SPACES. THE LOCATION OF SAID TREES SHALL BE LOCATED ANYWHERE IN THE PARKING AREA OR ADJACENT TO THE PARKING AREA.
16 PARKING SPACES = 2 TOTAL CLASS 'B' TREES REQUIRED

- LANDSCAPE LEGEND**
- CLASS 'A' TREE, MINIMUM CALIBER OF 2-1/2" AND MINIMUM HEIGHT OF 10'
 - CLASS 'B' TREE, MINIMUM CALIBER OF 1-1/2" AND MINIMUM HEIGHT OF 8'
 - SHRUBS, MINIMUM HEIGHT OF 3'
 - MULCH GROUND COVER

NOTE:
FOR EXAMPLES OF CLASS 'A' AND 'B' TREES, AND SHRUBS SPECIES SEE PEARL RIVER ORDINANCE #01-00, SECTION X.

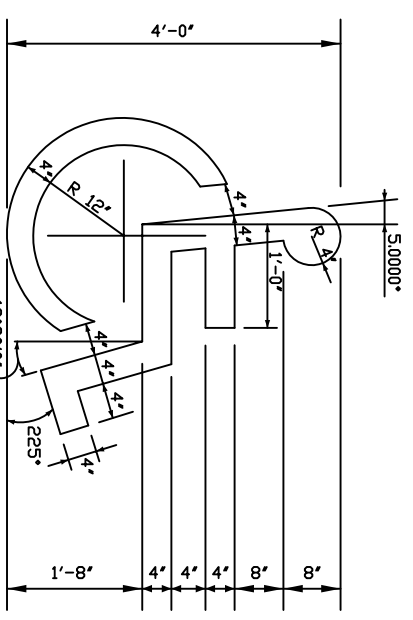

HANDICAP SYMBOL DETAIL
N. T. S.

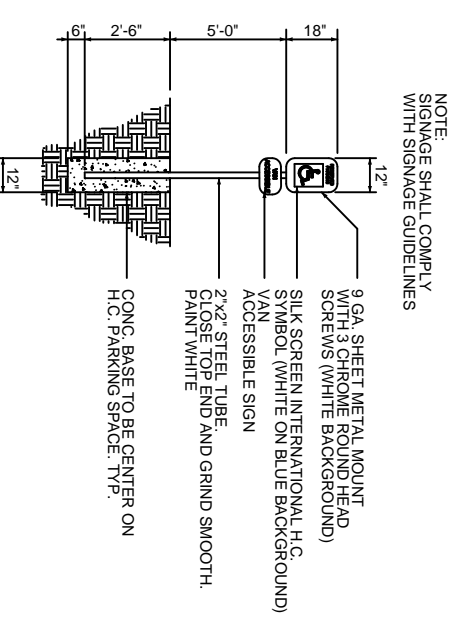

HANDICAP PARKING SIGN
N. T. S.

- NOTES**
1. 10"x10" CONCRETE DUMPSTER PAD WITH 6" WOODEN FENCE & GATES ENCLOSURE. ANY FENCING SHALL COMPLY WITH TOWN OF PEARL RIVER ORDINANCE. ADJUST FENCE HEIGHT AS NEEDED.
 2. DETECTABLE WARNING ON RAMP CUT 1/4" DEEP GROOVES @ 2" TO 3" O.C. AND SCORED INTO CONCRETE AND PAINTED (TYP. OF ALL RAMPS LEADING TO VEHICULAR AREAS (MAX SLOPE 1:12)
 3. ONE-WAY WAREHOUSE ACCESS FROM CLEO ROAD TO SUITES 1-4.
 4. NEW FIRE HYDRANT SHALL BE INSTALLED PER REQUIREMENTS OF TOWN OF PEARL RIVER.

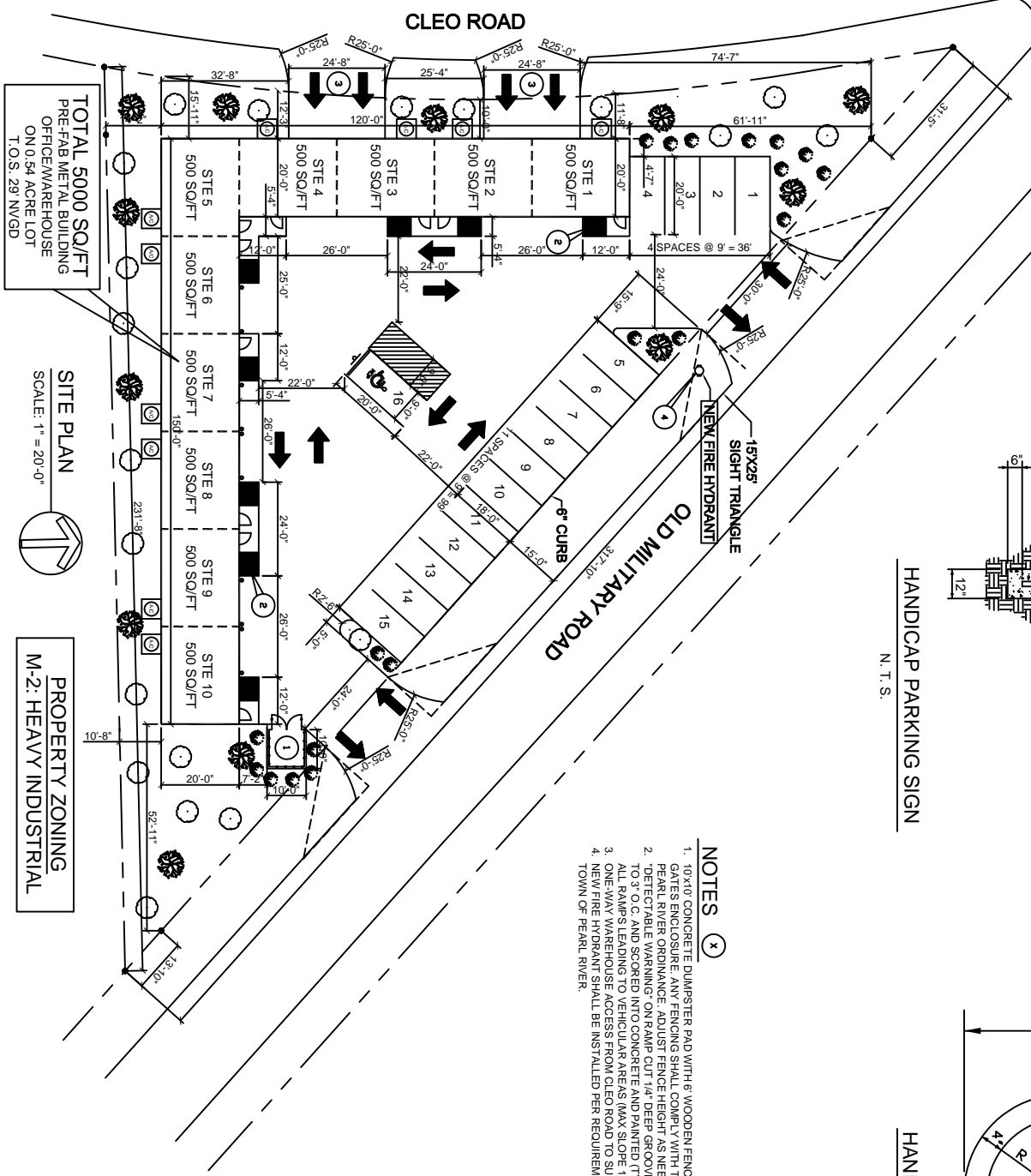

SITE PLAN
SCALE: 1" = 20'-0"
PROPERTY ZONING
M-2: HEAVY INDUSTRIAL

LEGEND

- PROPERTY LINE
- SETBACK
- NEW BUILDING OUTLINE
- SERVITUDE / EASEMENT
- NEW 6' WOODEN FENCE
- HANDICAP PARKING
- HANDICAP PARKING SIGN
- CONG. WASTE RECEPTACLE
- TRAFFIC FLOW DIRECTION
- PARKING BLOCK

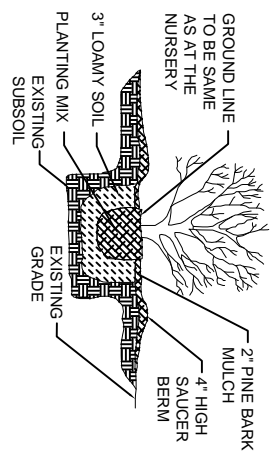

SHRUB DETAIL
N. T. S.

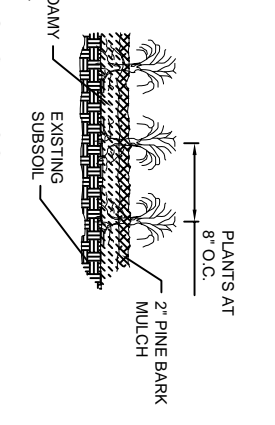

GROUND COVER DETAIL
N. T. S.

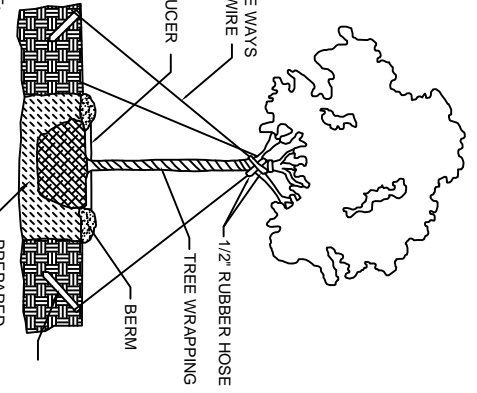

TYPICAL TREE PLANTING DETAIL
N. T. S.



VICINITY MAP
N.T.S.

REV:	
SCALE:	AS NOTED
JOB#:	1879
DATE:	09-14-07
SHEET	1
C-1	
OF 1	