

#400 LEEWARD LOOP

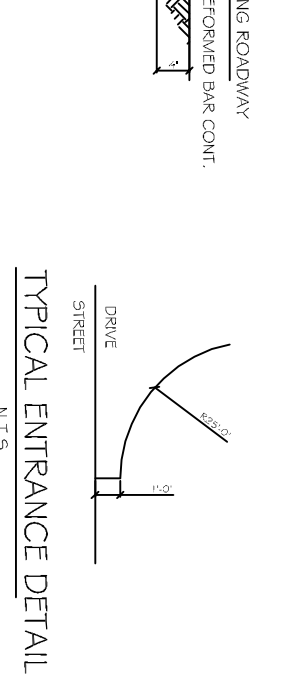

- PAVING NOTES:**
- 1) ALL NEW CONCRETE SHALL HAVE A MINIMUM COMPRESSIVE STRENGTH OF 4,000 PSI AT 28 DAYS AND A MINIMUM THICKNESS OF 6\"/>
 - 2) CONCRETE PAVING THICKNESS SHALL VARY AS FOLLOWS:
 - a) APRONS = 7\"/>
 - b) PARKING AREAS = 6\"/>
 - c) ALL REINFORCING STEEL SHALL BE SECURELY SUPPORTED TO PREVENT BOTH VERTICAL AND HORIZONTAL MOVEMENT DURING CONCRETE PLACEMENT. ALL CONTROL AND EXPANSION JOINTS SHALL BE LOCATED AND INSTALLED AS SHOWN ON THE PAVING PLAN AND IN ACCORDANCE WITH THE MANUFACTURER'S RECOMMENDATIONS.
 - d) ALL SUB GRADE FILL SHALL BE SELECT GRANULAR MATERIAL COMPACTED TO 95% STANDARD PROCTOR DENSITY IN A MAXIMUM OF 6\"/>
 - e) CONTRACTOR SHALL CONTACT THEIR REGULATORY DEPARTMENT OF ENGINEERING PRIOR TO CONDUCTING ANY WORK.
 - f) ANY WORK WITHIN THE ROADWAY OR ADJACENT TO THE ROADWAY CAUSING AN INTERFERENCE TO VEHICULAR TRAFFIC REQUIRES PRIOR APPROVAL FROM THE CITY TRAFFIC ENGINEERING DIVISION, AND MUST CONFORM TO THE REQUIREMENTS SET FORTH BY THE UNIFORM MANUAL OF TRAFFIC CONTROL DEVICES OF THE STATE OF LOUISIANA. THE CONTRACTOR MUST FURNISH ALL NECESSARY TRAFFIC SIGNS AND/OR BARRICADES AND MAINTAIN THEM DURING CONSTRUCTION ACTIVITY.

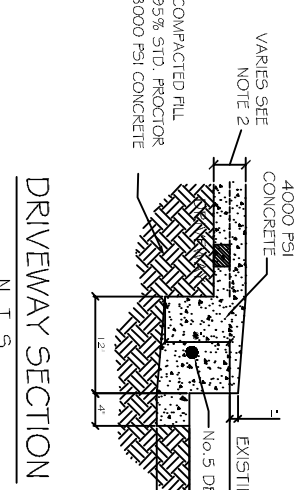
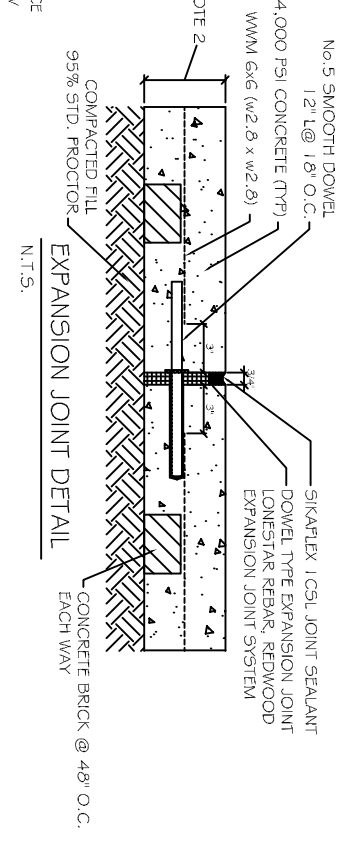
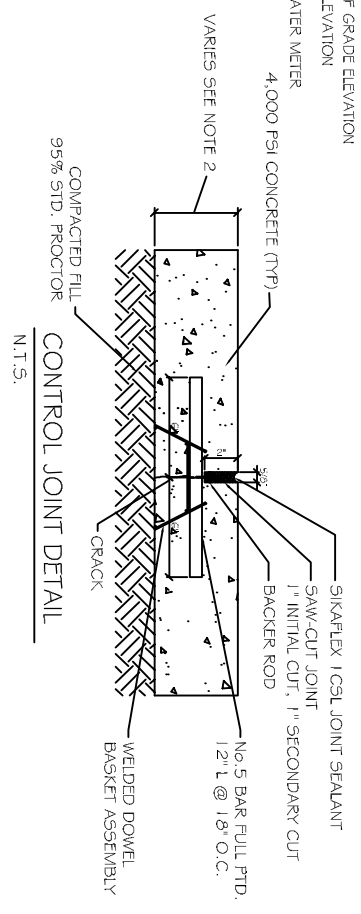

NOT APPROVED FOR CONSTRUCTION

REVISIONS	DATE
# DESCRIPTION	

**LANDIS TRANSPORT LLC
OFFICE/WAREHOUSE BUILDING**

LOT 2 1#400 LEEWARD LOOP
ST. TAMMANY PARISH COVINGTON LOUISIANA

JOB No: 2164 DATE: 01-30-2013

DRAWN BY: JCT CHECKED BY: CD

DAMMON ENGINEERING, INC.
Architects & Engineers

CHIEF ENGINEER: ENMETT DAMMON, P.E.
CHIEF ARCHITECT: KEVIN KINCHEN
554 OLD SPANISH TRAIL
SUDELL, LA 70458

dammoneng@dammoneng.com
dammoneng@bellsouth.net
PHONE: 905-649-5832
FAX: 905-641-5950