

NOTE: EXTERIOR LIGHTING SHALL BE SHADED OR INWARDLY DIRECTED IN SUCH A MANNER SO THAT NO DIRECT LIGHTING OR GLARE IS CAST BEYOND THE PROPERTY LINE. THE INTENSITY OF SUCH LIGHTING SHALL NOT EXCEED ONE FOOT CANDLE AS MEASURED AT THE ABUTTING PROPERTY LINE.

SITE PLAN
SCALE: 1"=20'-0"

PARKING REQUIREMENTS:
PROPOSED BUILDING
1st FLOOR=5,255 SQ.FT.
2ND FLOOR=5,255 SQ.FT.
10,500 SQ. FT.
TOTAL REQUIRED=30
TOTAL PROVIDED=28+2 HANDICAP=30

OAK HARBOR PARKING REQUIREMENTS:
1 SPACE PER 350 SQ. FT. OF FLOOR AREA
6100 TOTAL SQ. FT.
21 TOTAL SPACES REQUIRED
19 SPACES +
2 H.C. SPACES =
21 TOTAL SPACES PROVIDED

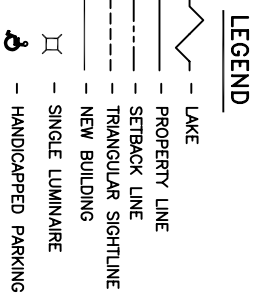

LANDSCAPE REQUIREMENTS
 - SOUTHERN LIVE OAK, 4" CALIPER, MINIMUM HEIGHT OF 12' AND 5' FOOT SPAN, PLANTED ONE EVERY 30' O.C.
 - RED OAK TREE—MINIMUM OF 12' HIGH, CALIPER OF 2-1/2" ONE PER 30' O.C.
 - SHRUB, ONE PER 10' O.C.

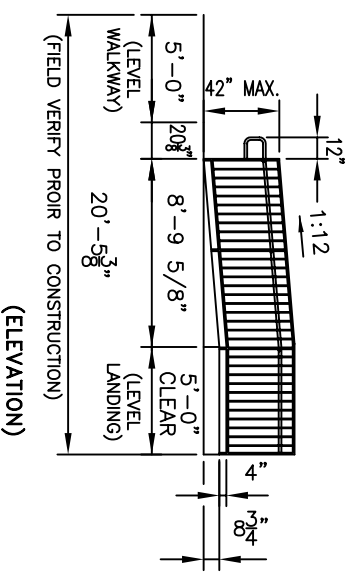
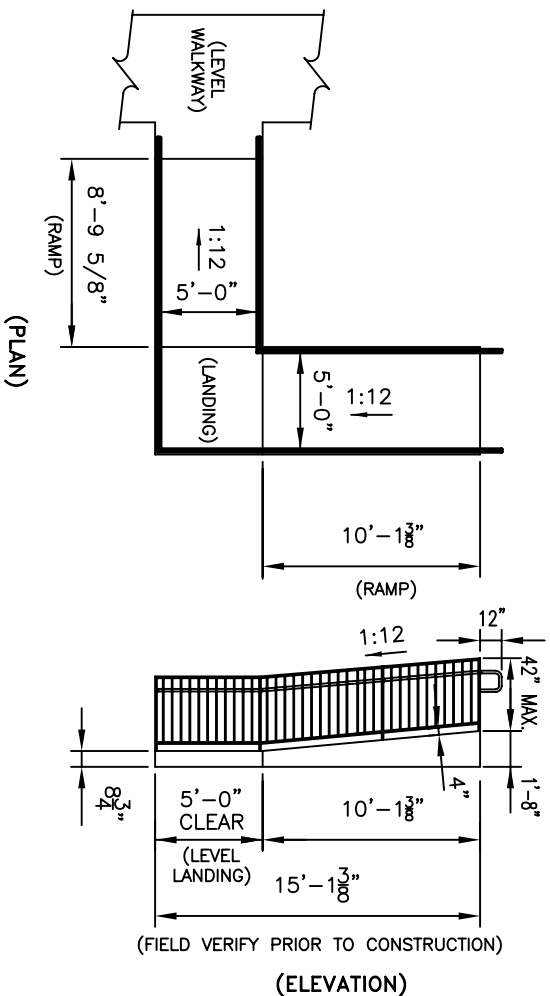

RAMP DETAIL
SCALE: 3/16"=1'-0"

LEVEL 10 MARKETING BUILDING
DAMMON ENGINEERING, INC.
 1095 FLORIDA AVENUE 985-649-5832 SLIDELL, LA. 70458
 DAMMONENGINEERING.COM

SITE PLAN
 LEVEL 10 MARKETING
 OAK HARBOR BLVD.
 SLIDELL, LA

SCALE: AS NOTED
 FILE:
 JOB NO. 1675
 DATE: 04-07-05
 SHEET
C-1
 OF