



Series: PFG -HH, HV

**Submersible Grinder Pumps
1-1/4" Discharge, 2 HP, High-Head & High-Volume**



DISCHARGE	1-1/4" NPT Vertical, Bolt-on Flange
LIQUID TEMPERATURE	160°F Intermittent
VOLUTE	Cast Iron, Class 30
MOTOR HOUSING	Cast Iron, Class 30
SEAL PLATE	Cast Iron, Class 30
IMPELLER	12 Vane, Vortex, Bronze
SHREDDING RING	Stainless Steel
CUTTER	Stainless Steel
SHAFT	Stainless Steel
SQUARE RINGS	Buna-N
HARDWARE	Stainless Steel
PAINT	Powder Coated - Industrial Grade
SEAL	Tandem Double Mechanical, Carbon/Ceramic/Buna-N
UPPER BEARING	Single row, Ball, Oil Lubricated
INTERMEDIATE BEARING	Single row, Ball, Oil Lubricated
LOWER BEARING	Sleeve, Oil Lubricated
POWER CORD	20 ft. Custom Molded, Fast Disconnect, for Sealing and Strain Relief. CSA approved, 12/4 Type SOW
MOTOR	Oil Filled, Squirrel Cage Induction, Class B Insulation
SINGLE PHASE	Capacitor Start/Capacitor Run. Includes overload protection in the motor. Requires starter or control panel which includes capacitors.
THREE PHASE	Dual Voltage 230/460.

**Series: PFG2002HV & HH
PFG2022HV & HH
PFG2062HV & HH
PFG2032HV & HH
PFG2042HV & HH**

**2 HP • 3450 RPM • 60 Hz
Submersible Grinder Pump**

NOTE: Consult factory before making modifications as they may effect CSA listing.

Description

Designed to reduce domestic, commercial, institutional and light industrial sewage to a finely ground slurry.

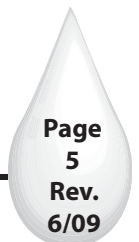

Series: PFG-HH, HV



Submersible Grinder Pumps
1-1/4" Discharge, 2 HP, High-Head & High-Volume

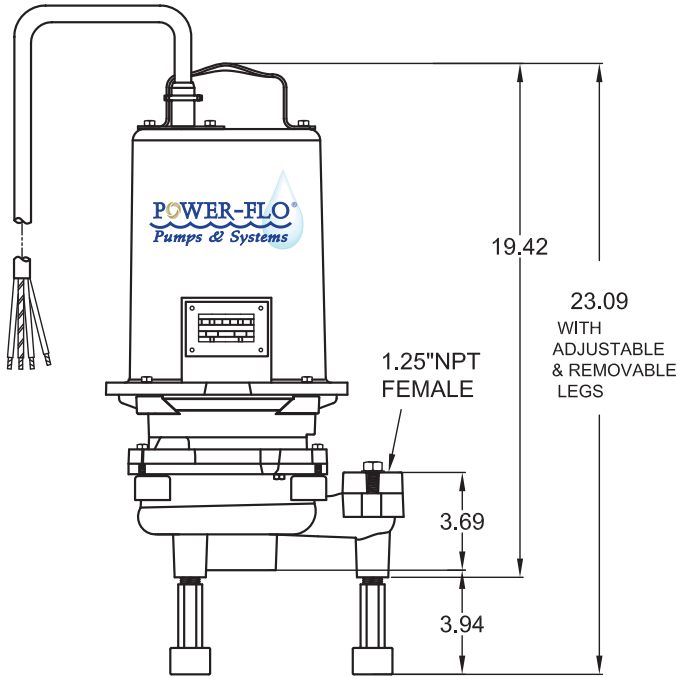

IMPORTANT! - Pump Suction **MUST** be a minimum of 4" from basin floor with use of legs, stand or slide rail system.

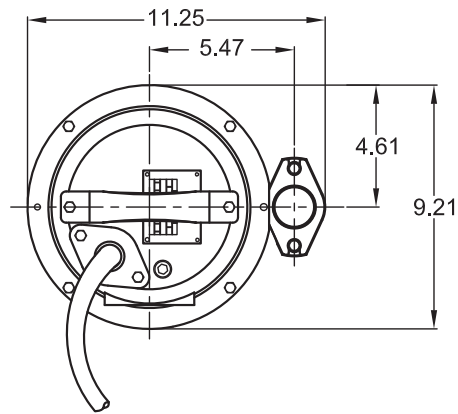

MODEL	HP	Hz	Volts/Ph	RPM	Full Load Amps	Locked Rotor Amps	NEMA Start Code	Cord Type	Cord Size	Cord O.D.	Simplex Control	Duplex Control
High Volume												
PFG2002HV	2	60	200/1	3450	17.0	53.0	F	SOW	12/4	.67	PF1021-C	PF2021-C
PFG2022HV	2	60	230/1	3450	15.0	53.8	H	SOW	12/4	.67	PF1023-C	PF2023-C
PFG2062HV	2	60	200/3	3450	11.0	42.0	J	SOW	12/4	.67	PF1022-O	PF2022-O
PFG2032HV	2	60	230/3	3450	9.0	36.0	J	SOW	12/4	.67	PF1024-O	PF2024-O
PFG2042HV	2	60	460/3	3450	4.0	18.0	J	SOW	12/4	.67	PF1025-O	PF2025-O
High Head												
PFG2002HH	2	60	200/1	3450	17.0	53.0	F	SOW	12/4	.67	PF1021-C	PF2021-C
PFG2022HH	2	60	230/1	3450	15.0	53.8	H	SOW	12/4	.67	PF1023-C	PF2023-C
PFG2062HH	2	60	200/3	3450	11.0	42.0	J	SOW	12/4	.67	PF1022-O	PF2022-O
PFG2032HH	2	60	230/3	3450	9.0	36.0	J	SOW	12/4	.67	PF1024-O	PF2024-O
PFG2042HH	2	60	460/3	3450	4.0	18.0	J	SOW	12/4	.67	PF1025-O	PF2025-O

IMPORTANT!

These pumps are not approved for use in swimming pools, recreational water parks, or installations where human contact with pumped media is a common occurrence.



Series: PFG-HH

Submersible Grinder Pumps
1-1/4" Discharge, 2 HP, High-Head

