

THE SCOUT POOL LIFT

US PATENT NO. D507,769 S

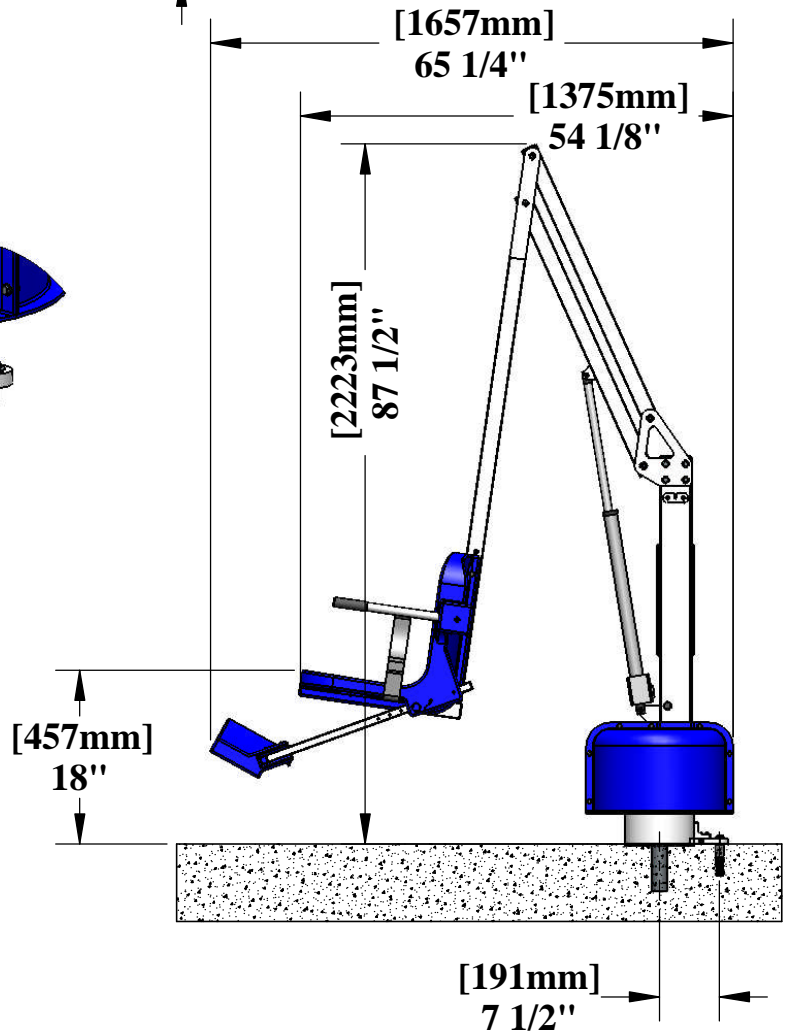
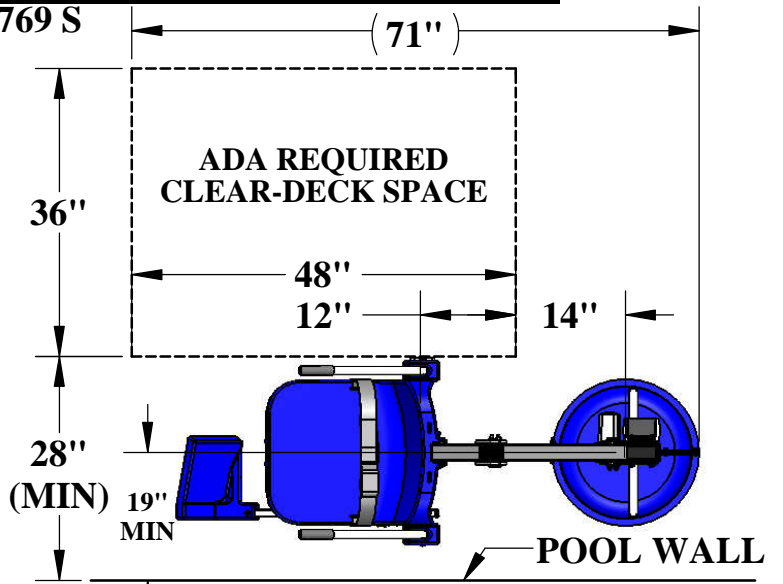
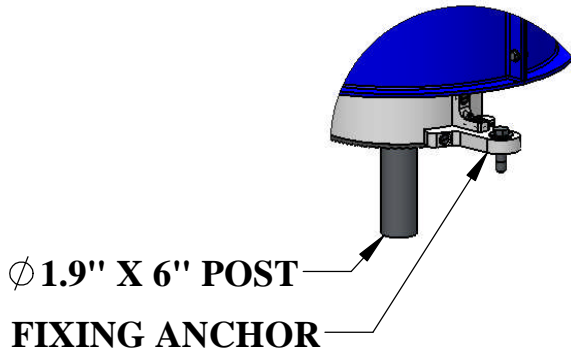
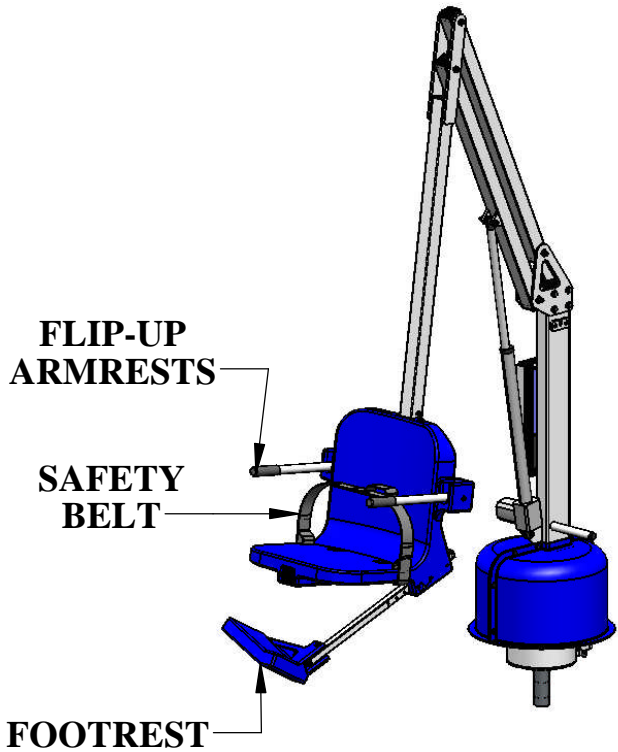

Inspected And Verified To Meet
Applicable Sections of ADA
Guidelines Section 1009.2 By

wyle
laboratories

A Registered ISO 9001
Laboratory

Aqua Creek Products

The Total Solution for Pool and Spa Access

9889 GARRYMORE LANE
MISSOULA, MT 59808
(406) 549-0769
FAX (406) 549-2602

NOTE:
*SPECIFICATIONS ARE SUBJECT TO CHANGE WITHOUT NOTICE

PRODUCT:	F-800SC-DER-D	
DWG #:	F-800SC-DER-D-1	
SCALE:	1:24	DATE: 10/31/14
DRAWN BY:	KR	REVISION: M

THE SCOUT POOL LIFT

US PATENT NO. D507,769 S

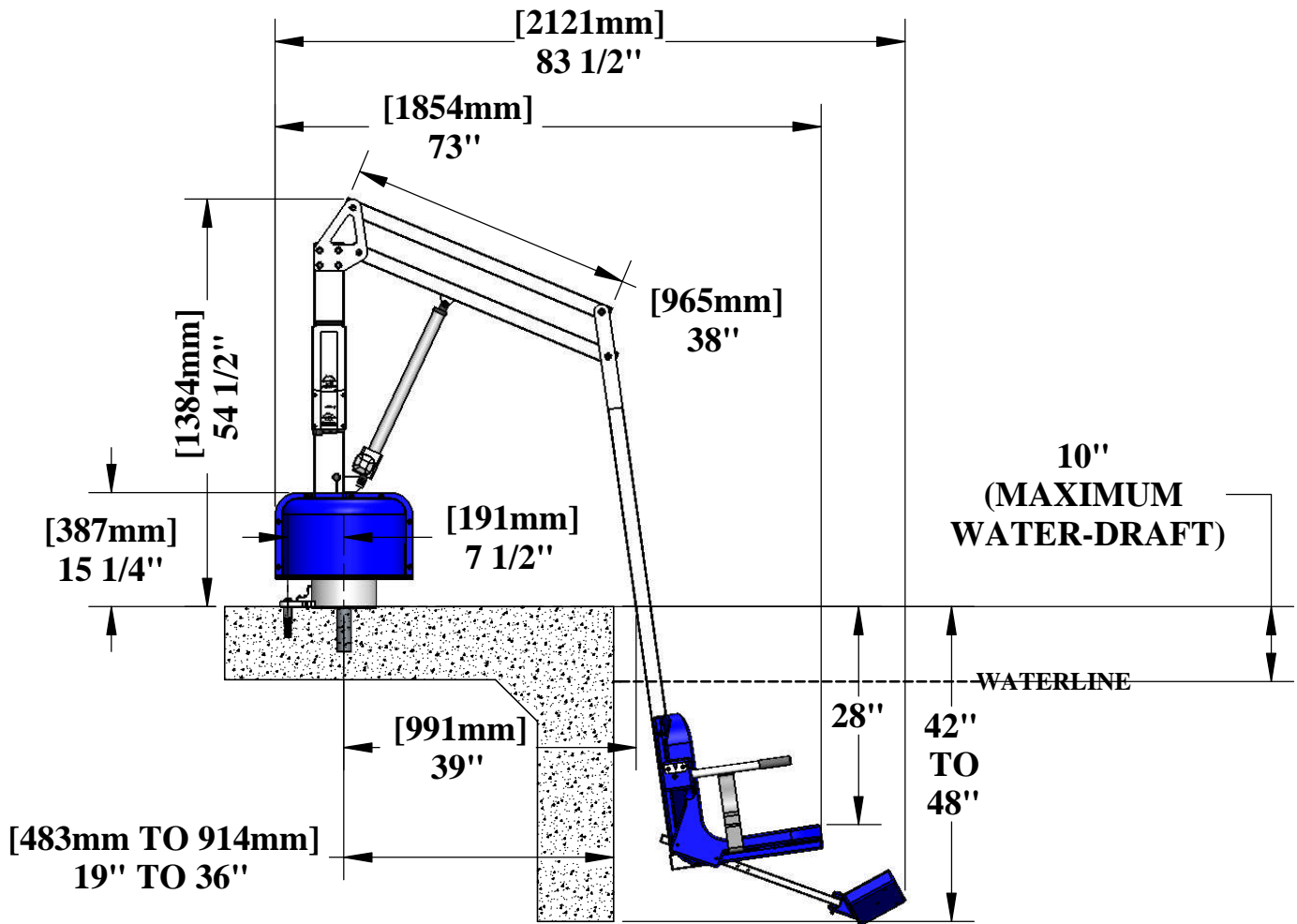
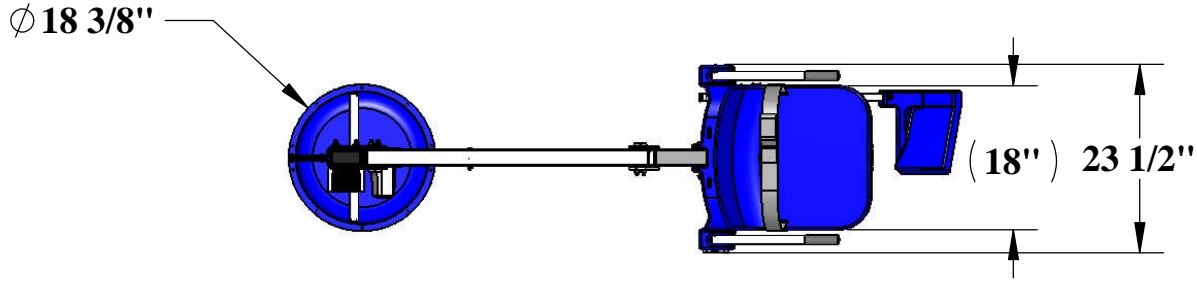

Aqua Creek Products
 The Total Solution for Pool and Spa Access

9889 GARRYMORE LANE
 MISSOULA, MT 59808
 (406) 549-0769
 FAX (406) 549-2602

NOTE:
 *SPECIFICATIONS ARE SUBJECT TO CHANGE WITHOUT NOTICE

PRODUCT:	F-800SC-DER-D	
DWG #:	F-800SC-DER-D-2	
SCALE:	1:24	DATE: 10/31/14
DRAWN BY:	KR	REVISION: M

THE SCOUT POOL LIFT

US PATENT NO. D507,769 S

SPECIFICATIONS:

***LIFTING CAPACITY: 350lbs [159kg]**
STATIC LOAD CAPACITY: 525 lbs [238kg]

MAXIMUM WATER DRAFT (DECK TO WATER): 10" [254mm]
MAXIMUM SETBACK: 36" [914mm]

WEIGHT: 175 lbs [79 kg]

MATERIALS:

BASE: TYPE 304 STAINLESS STEEL, PVC, CONCRETE, RUBBER
MAST & ARMS: TYPE 304 STAINLESS STEEL
CHAIR & FOOTREST: LOW-DENSITY POLYETHYLENE
SAFETY BELT: HEAVY-DUTY POLYESTER STRAP, HOOK & LOOK FASTENER
POWDER COATING: OFF-WHITE POLYESTER [PN: 1PC-108-1912 BX50]
FIXING ANCHOR-TAB: HIGH-DENSITY POLYETHYLENE
FIXING BOLT: ϕ 1/2"-13 X 2", 316 SS

STANDARD EQUIPMENT:

FLIP-UP ARMRESTS
FLIP-UP FOOTREST
ELECTRONICS COVER

24V BATTERY & CHARGER
WATER RESISTANT HANDSET/REMOTE
SAFETY BELT

ACCESSORIES:

10" DEEP ANCHOR
CHEST STRAP
CYCLE ATTACHMENT
HEADREST
UPGRADE PACK

LOCKABLE COVER
PULL-OUT LEGREST
SOLAR CHARGING STATION
WOOD DECK ANCHOR
TRANSPORT CART

ADAPTOR SLEEVES FOR RETRO-FIT:

2.36" 2.49"
2.75"

***NOTE: LIFTING CAPACITY IS 300lbs [136kg] WITH ANCHOR ADAPTERS**



9889 GARRYMORE LANE
MISSOULA, MT 59808
(406) 549-0769
FAX (406) 549-2602

NOTE:
*SPECIFICATIONS ARE SUBJECT TO CHANGE WITHOUT NOTICE

PRODUCT:	F-800SC-DER-D	
DWG #:	F-800SC-DER-D-3	
SCALE:	1:1	DATE: 10/31/14
DRAWN BY:	KR	REVISION: M