

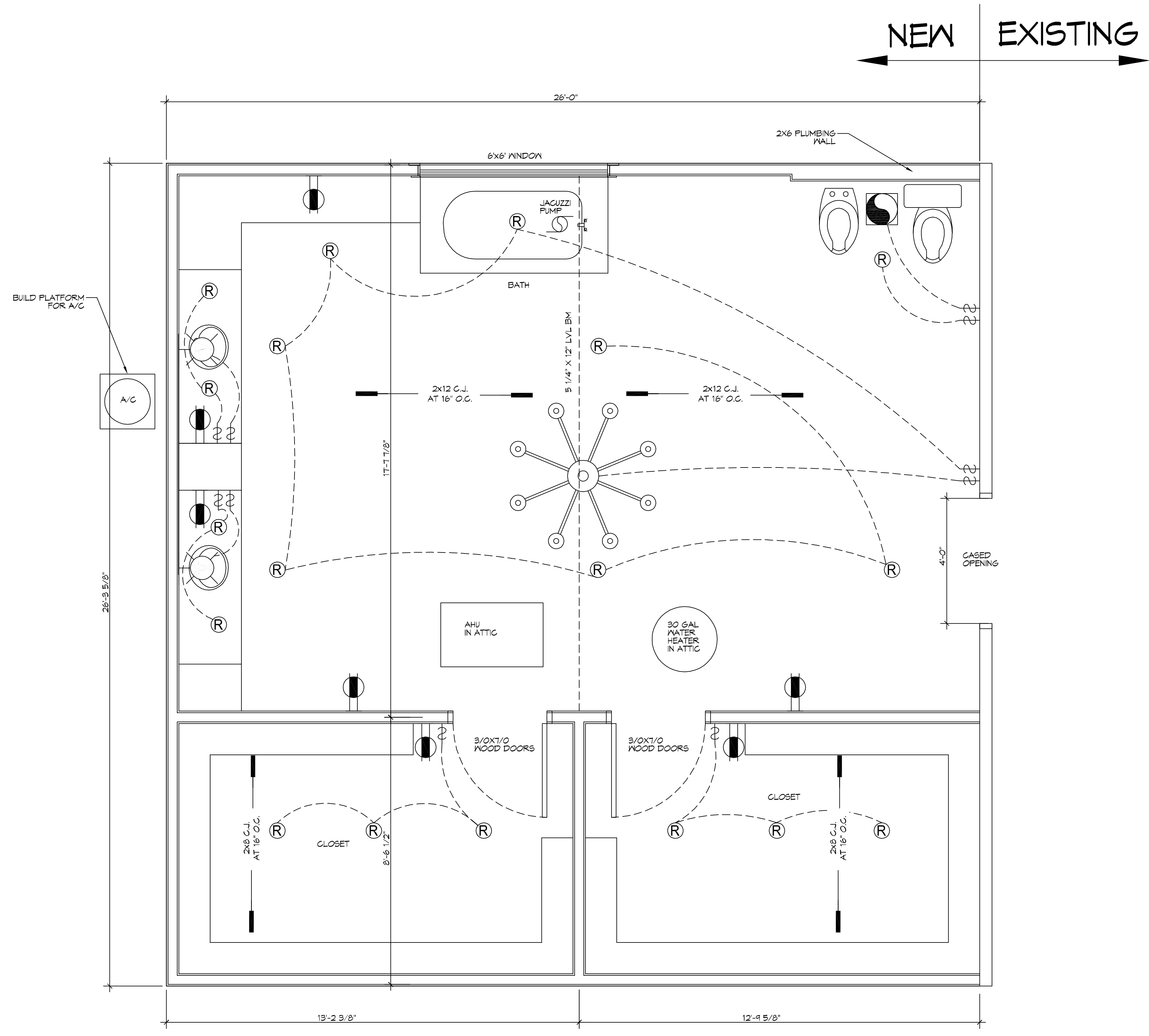





FILE NAME: \\A:\PROJECTS\Bathroom Addition\Drawings\A101.dwg Date: 05/04/2018 10:11:42 AM



**1 BATHROOM LAYOUT**  
SCALE: 1/2" = 1'-0"  
ARCHITURAL

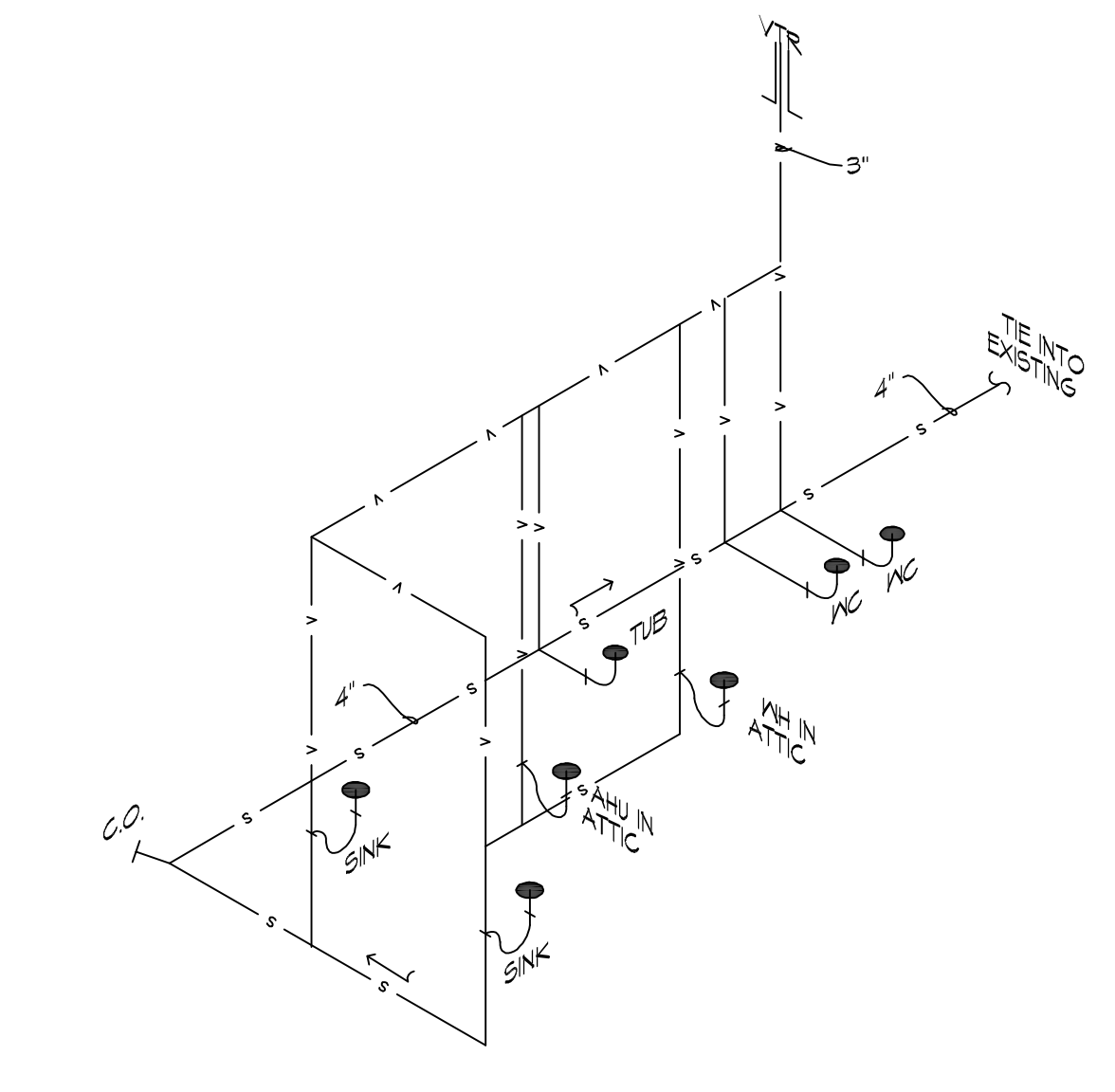

**2 PLUMBING LAYOUT**  
SCALE: 1/4" = 1'-0"  
PLUMBING

**NOTE**  
VERIFY WITH OWNER ALL PLUMBING FIXTURE TYPES, ELECTRICAL FIXTURE TYPES AND SIDING MATERIALS PRIOR TO CONSTRUCTION.

**DAMMON ENGINEERING, INC.**  
LOUISIANA & MISSISSIPPI  
www.dammonengineering.com  
info@dammonengineering.com  
Chief Engineer: Brian Mistich, PE  
554 Old Spanish Trail  
Slidell, LA 70468  
PH: 985.649.5832

#	DESCRIPTION	DATE



**BATHROOM ADDITION**  
**THE CLEMENTS**  
199 CHAYALE DRIVE  
SLIDELL, LA 70458  
JOB No: 2018 DATE: 05-04-2018  
DRAWN BY: CKD CHECKED BY: BAK

SHEET TITLE:  
FLOOR PLAN

DRAWING NUMBER:  
**A101**

