

DTG: MMS - A1 - 02/02/2024 (Sheet) 2102 - Chief Architect - Dammon & Sons, Inc. - 2024 - 02/02/2024 - 02/02/2024

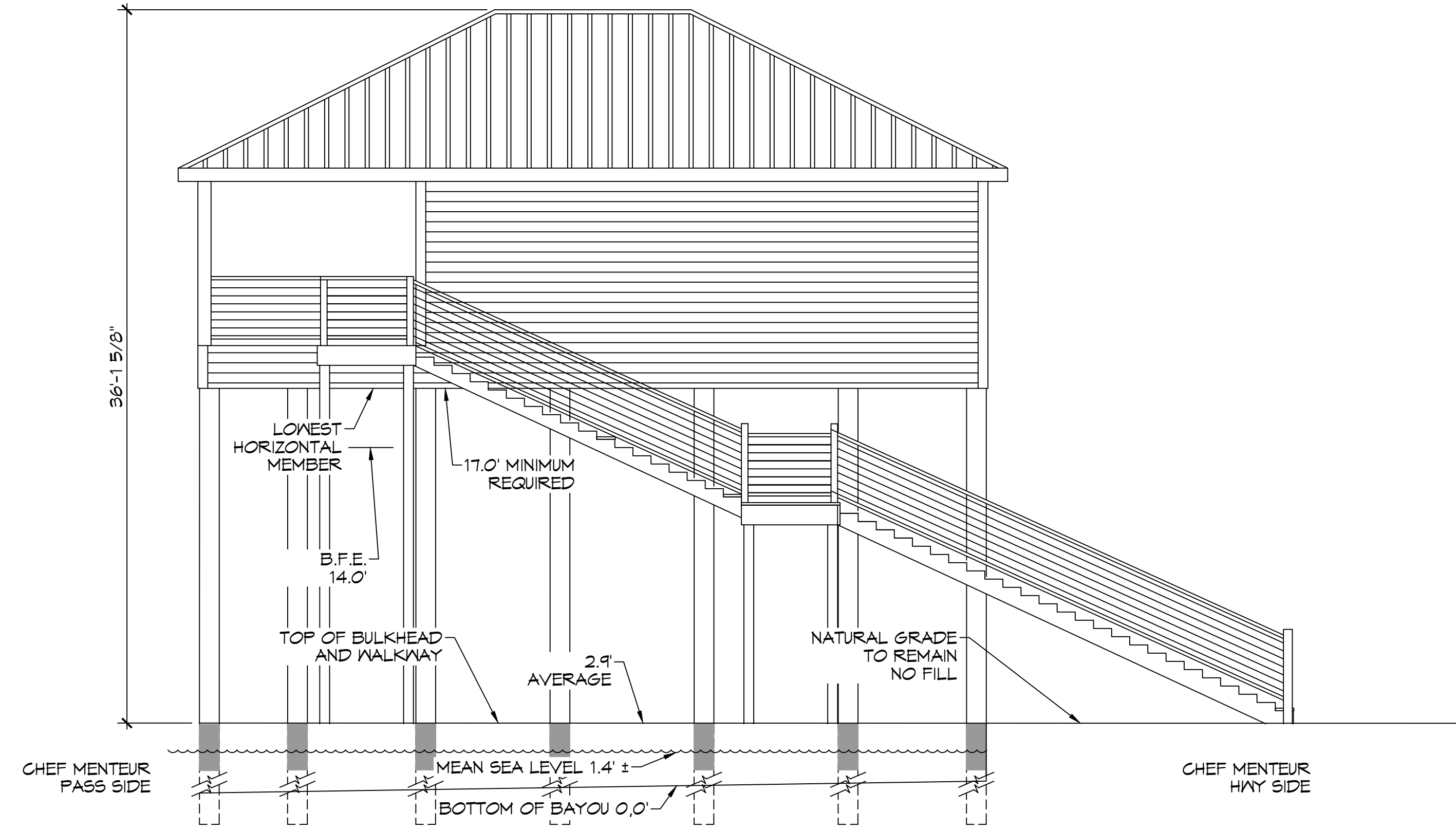

A
 C101 C102 SCALE: 1" = 5'-0"
PROPOSED CROSS SECTION

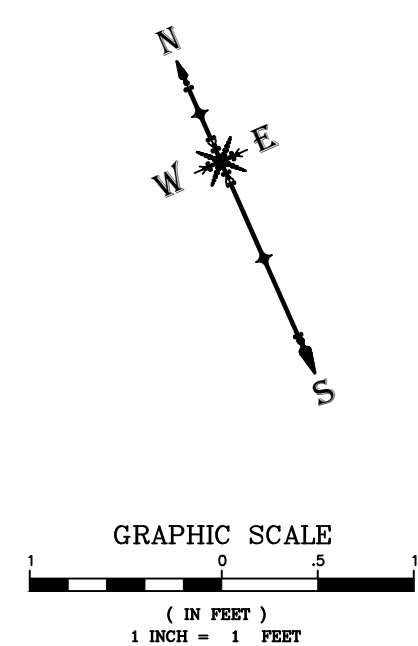

DAMMON
ENGINEERING, INC.
 LOUISIANA & MISSISSIPPI
 Chief Engineer: Brian Mistich, PE
 554 Old Spanish Trail
 Slidell, LA 70458
 www.dammonengineering.com
 info@dammonengineering.com
 PH: 985-649-5832

#	DESCRIPTION	DATE

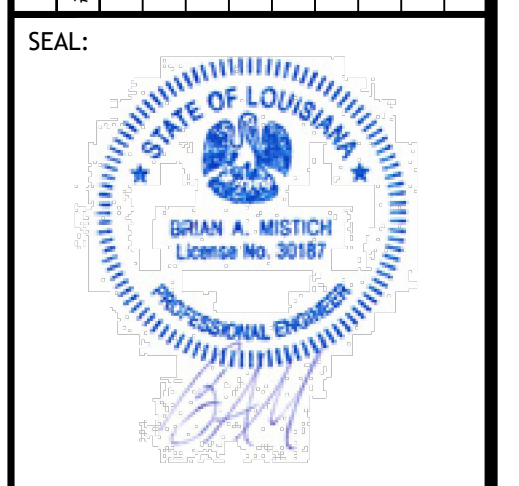

BOAT HOUSE PLAN
ALBERT CUITTO
 LOT 16
 2781 CHEF MENTEUR HWY
 NEW ORLEANS, LOUISIANA 70128
 JOB No: 2024 DATE: 02-02-2024
 DRAWN BY: CKD CHECKED BY: BAW

SHEET TITLE:
 PROPOSED SECTION OF
 SITE PLAN

DRAWING NUMBER:
C102
 SHEET No: 2 of 13

P:\MISC - ARCHITECTURE\Projects\03103 - Boat House Framing\03103 - Boat House Framing.dwg, 05/02/2024, 10:28:18 AM, Brian Mistich, 05/02/2024, 10:28:18 AM

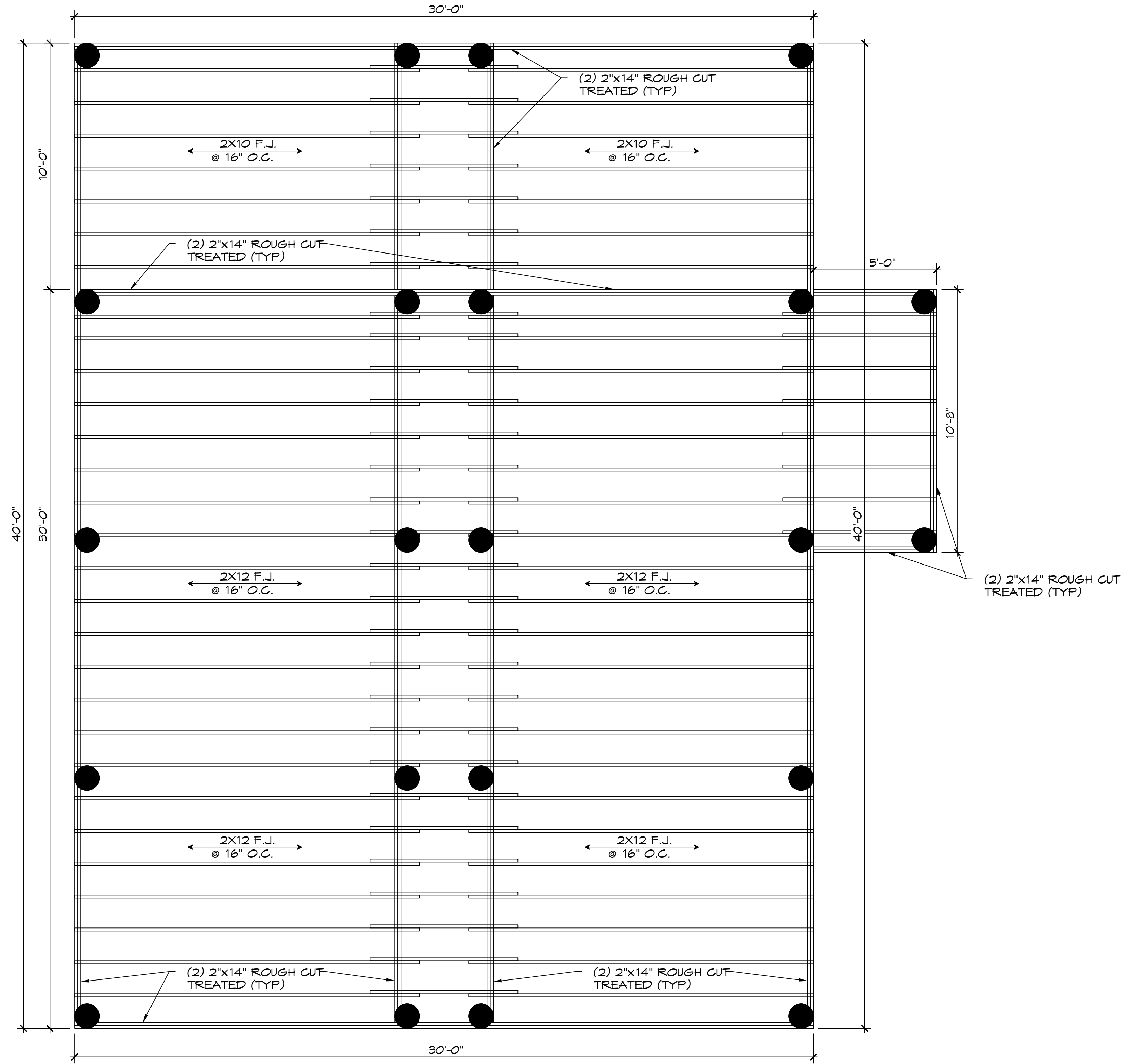

FLOOR FRAMING PLAN
SCALE: 3/8" = 1'-0"

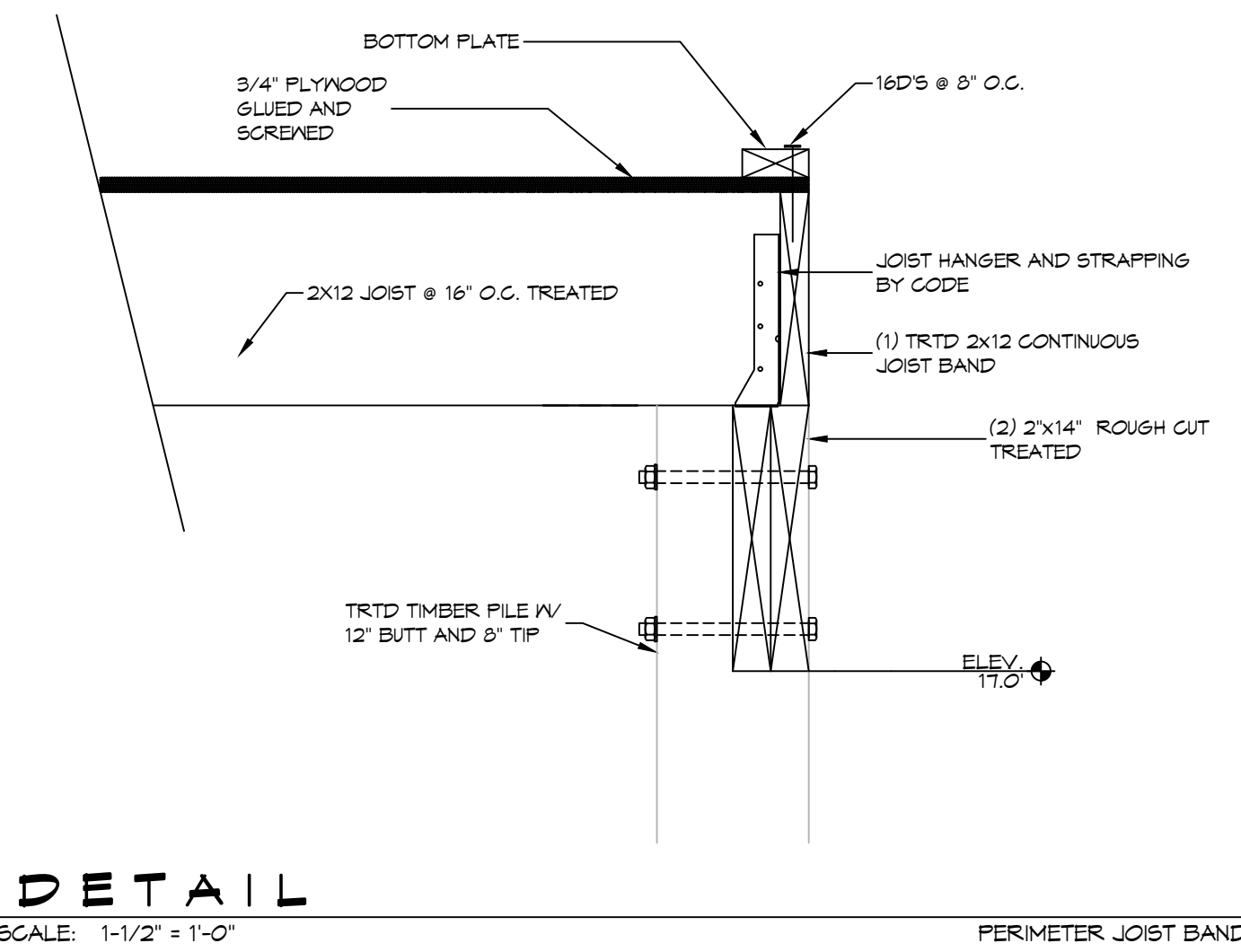

DETAIL
SCALE: 1-1/2" = 1'-0" PERIMETER JOIST BAND

- GENERAL NOTES**
- ALL LUMBER SHALL BE PRESSURE TREATED WITH A RETENTION OF .4 PER C.F.
 - ALL FASTENERS SHALL BE HOT DIPPED GALVANIZED (HDG) PER ASTM A193.
 - ALL CONNECTORS SHALL BE HDG PER ASTM A693, CLASS 6185 SHEET WITH 1.85 OZ/SF ZINC COATING.
 - TRIPLE UP FLOOR JOIST UNDER TUB AND INTERIOR LOAD BEARING WALLS.

DAMMON ENGINEERING, INC.
LOUISIANA & MISSISSIPPI

Chief Engineer: Brian Mistich, PE
554 Old Spanish Trail
Slidell, LA 70458
www.dammonengineering.com
info@dammonengineering.com
PH: 985.649.8832

#	DESCRIPTION	DATE

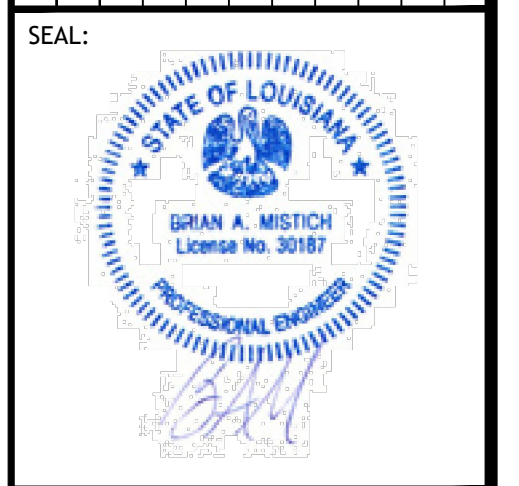

BOAT HOUSE PLAN

ALBERT CUITTO

LOT 16
21181 CHEF MENTEURS HWY
NEW ORLEANS, LOUISIANA 70124

JOB No: 2024 | DATE: 05-02-2024
DRAWN BY: CKD | CHECKED BY: BAM

SHEET TITLE:
FLOOR FRAMING PLAN

DRAWING NUMBER:
S103

SHEET No: 5 of 13

TABLE S601.7 - UPLIFT CONNECTIONS - 164 MPH WINDS EXP "D"
NFCM 2015 TABLE 3.2

CONNECTION	FRAMING SPACING (INCHES)	ROOF SPAN (FEET)	UPLIFT	LATERAL	SHEAR	NUMBER OF 8d COMMON NAILS OR 10d BOX NAILS IN EACH END OF 1-1/4" X 20 GAUGE STRAP
ROOF ASSEMBLY TO WALL ASSEMBLY	16" OC	16	401	292	152R	4
WALL ASSEMBLY TO FOUNDATION	16" OC	16	224	219	436	4

TABLE S601.8 - SILL OR BOTTOM PLATE TO FOUNDATION CONNECTIONS RESISTING UPLIFT LOADS - 164 MPH WIND EXP "D"
NFCM 2015 TABLE 3.2C

BOTTOM PLATE TO FOUNDATION ANCHOR BOLT CONNECTION RESISTING	FOUNDATION SUPPORTING	MAXIMUM ANCHOR BOLT SPACING (INCHES)	
		8' END ZONES	INTERIOR ZONES
UPLIFT LOADS	1 - 3 STORIES	25 INCHES ON CENTER	30 INCHES ON CENTER

NOTE: A MINIMUM OF ONE ANCHOR BOLT SHALL BE PROVIDED WITHIN 6 TO 12 INCHES OF EACH END OF EACH PLATE

TABLE S601.9 - SILL OR BOTTOM PLATE TO FOUNDATION CONNECTIONS RESISTING SHEAR LOADS - 164 MPH WIND EXP "D"
NFCM 2015 TABLE 3.2B

BOTTOM PLATE TO FOUNDATION ANCHOR BOLT CONNECTION RESISTING	FOUNDATION SUPPORTING	MAXIMUM ANCHOR BOLT SPACING (INCHES)	
		5/8" Ø ANCHOR BOLTS	5/8" Ø ANCHOR BOLTS
UPLIFT LOADS	4 STORY	48 INCHES ON CENTER W/3X3X1/4" WASHER	

TABLE S601.10 - FULL HEIGHT STUD REQUIREMENT FOR HEADERS OR WINDOW SILL PLATES IN EXTERIOR WALLS EXPOSURE "D"
NFCM 2015 TABLE 3.23C

HEADER SPAN (FEET)	WALL SPACING (INCHES)		
	12" O.C.	16" O.C.	24" O.C.
2	1	1	1
4	2	2	1
6	3	3	2
8	4	3	2

TABLE S601.5 - JACK STUD REQ - INT LOADBEARING WALLS

HEADER SUPPORTING	HEADER SPAN (FT)	ROOF SPAN (FEET)												
		12 FEET				24 FEET				36 FEET				
		3"	4.5"	5"	6.5"	3"	4.5"	5"	6.5"	3"	4.5"	5"	6"	
ONE FLOOR ONLY (CENTER BEARING)	2	1	1	1	1	1	1	1	1	1	1	1	1	
	4	1	1	1	1	1	1	1	1	1	1	1	1	
	6	1	1	1	1	1	1	1	1	2	1	1	1	
	8	1	1	1	1	2	1	1	1	2	2	2	1	
	10	1	1	1	1	2	2	1	1	3	2	2	2	
	12	1	1	1	1	2	2	2	1	3	2	2	2	
	14	2	1	1	1	3	2	2	2	4	3	3	2	
	16	2	2	1	1	3	2	2	2	4	3	3	2	
	TWO FLOORS (CENTER BEARING)	2	1	1	1	1	1	1	1	1	2	1	1	1
		4	1	1	1	1	2	1	1	1	3	2	2	2
6		2	1	1	1	3	2	2	2	4	3	2	2	
8		2	2	1	1	3	2	2	2	5	3	3	3	
10		2	2	2	1	4	3	3	2	6	4	4	3	
12		3	2	2	2	5	3	3	3	7	5	4	4	
14		3	2	2	2	6	4	4	3	8	5	5	4	
16		4	3	2	2	6	4	4	3	9	6	6	5	

TABLE S601.6 - JACK STUD REQ - EXTERIOR LOADBEARING WALLS
NFCM 2015 TABLE 3.22F

ROOF AND CEILING	HEADER WIDTH - 3" (2-2X), 4.5" (3-2X), 5", 6.5" (4-2X) EACH 1/2" PLYWOOD SPACER BETWEEN	ROOF LIVE LOAD 20 PSF				ROOF LIVE LOAD 30 PSF				
		3"	4.5"	5"	6.5"	3"	4.5"	5"	6.5"	
		NUMBER OF JACK STUDS REQUIRED								
ROOF AND CEILING	2	1	1	1	1	1	1	1	1	
	4	1	1	1	1	1	1	1	1	
	6	2	1	1	1	2	1	1	1	
	8	2	2	2	1	2	2	2	1	
	10	3	2	2	2	3	2	2	2	
	12	3	2	2	2	3	2	2	2	
	14	4	3	2	2	4	3	2	2	
	16	4	3	3	2	4	3	3	2	
	ROOF, CEILING, AND ONE CENTER BEARING FLOOR	2	1	1	1	1	1	1	1	1
		4	2	1	1	1	2	1	1	1
6		2	2	2	1	3	2	2	2	
8		3	2	2	2	3	2	2	2	
10		4	3	2	2	4	3	3	2	
12		4	3	3	2	5	3	3	3	
14		5	4	3	3	5	4	3	3	
16		6	4	4	3	6	4	4	3	

TABLE S601.3 - NAILING SCHEDULE
NFCM 2015 TABLE 3.1

DESCRIPTION	NUMBER OF COMMON NAILS	NUMBER OF BOX NAILS	SPACING
HEADER TO HEADER (FACE NAILED)	16d	16d	16" OC EDGES

TABLE S601.4 - BUILDING ENVELOPE REQUIREMENTS

ROOFS	OPAQUE ELEMENTS	ASSEMBLY MAXIMUM	INSULATION MIN. R-VALUE
	INSULATION ENTIRELY ABOVE DECK	U-0.048	R-20.0 c.i.
WALLS, ABOVE GRADE	METAL BUILDING	U-0.065	R-19
	ATTIC AND OTHER	U-0.027	R-38
FLOORS	MASS	U-0.151	R-5.7 c.i.
	METAL BUILDING	U-0.113	R-19.0
	STEEL-FRAMED	U-0.124	R-19.0
	WOOD-FRAMED AND OTHER	U-0.089	R-19.0
SLAB-ON-GRADE	MASS	U-0.107	R6-3 c.i.
	STEEL JOIST	U-0.052	R-19.0
OPAQUE DOORS	WOOD FRAMED AND OTHER	U-0.051	R-19.0
	UN-HEATED	F-0.750	NR
SLAB-ON-GRADE	SWINGING	U-0.700	NR
	NON-SWINGING	U-1.450	NR

METAL ROOF APPLICATION & FASTENING NOTES

1. INSTALL 26 GAUGE METAL ROOF PER MANUFACTURER'S RECOMMENDATIONS FOR 164 MPH WIND SPEED.

GENERAL UPLIFT CONNECTION NOTES

ROOF ASSEMBLY TO WALL ASSEMBLY: UPLIFT CONNECTIONS SHALL BE FROM RAFTER OR TRUSS TO WALL STUD. WHEN RAFTERS OR TRUSSES ARE NOT LOCATED DIRECTLY ABOVE STUDS, RAFTERS SHALL BE ATTACHED TO THE WALL PLATE AND THE WALL TOP PLATE SHALL BE ATTACHED TO THE WALL STUD WITH UPLIFT CONNECTIONS. UPLIFT CONNECTIONS SHALL BE IN ACCORDANCE WITH TABLE S601.10.

WALL ASSEMBLY TO WALL ASSEMBLY: STORY TO STORY UPLIFT CONNECTIONS FROM UPPER STORY WALL STUD TO LOWER STORY WALL STUD. WHEN UPPER STORY WALL STUDS ARE NOT LOCATED DIRECTLY ABOVE LOWER WALL STUDS, THE STUDS SHALL BE ATTACHED TO A COMMON MEMBER IN THE FLOOR ASSEMBLY BY UPLIFT CONNECTIONS. UPLIFT CONNECTIONS SHALL BE IN ACCORDANCE WITH TABLE S601.11.

WALL ASSEMBLY TO FOUNDATION: FIRST FLOOR WALL STUDS SHALL BE CONNECTED TO THE FOUNDATION, SILL PLATE, OR BOTTOM PLATE. A MINIMUM OF A 1-1/4" X 20 GA. ASTM A653 GRADE 33 STEEL STRAP SHALL BE NAILED TO THE WALL STUDS AND HAVE A MINIMUM EMBEDMENT OF 1 INCHES IN CONCRETE FOUNDATIONS AND SLABS-ON-GRADE, 15 INCHES IN MASONRY BLOCK FOUNDATIONS, OR BE LAPPED UNDER THE BOTTOM PLATE, 3 INCH SQUARE WASHERS SHALL BE USED ON THE ANCHOR BOLTS AND ANCHOR BOLT SPACINGS SHALL NOT EXCEED THE REQUIREMENTS. STEEL STRAPS EMBEDDED IN OR IN CONTACT WITH SLAB-ON-GRADE OR MASONRY BLOCK FOUNDATIONS SHALL BE HOT-DIPPED GALV. AFTER FABRICATION, OR MANUF. FROM S195 OR 2450 GALV. STL. CONNECTIONS SHALL BE IN ACCORDANCE WITH TABLE S601.12.

TABLE S601.1 - ROOF SHEATHING ATTACHMENT REQUIREMENT - WIND LOAD EXP "D"

SHEATHING LOCATION	RAFTER / TRUSS SPACING	E F	
		MAX NAIL SPACING FOR 8d COMMON NAILS OR 10d BOX NAILS (INCHES OC)	
INTERIOR ZONE	12" OC	6	12
	16" OC	6	12
	24" OC	6	12
PERIMETER EDGE ZONE	12" OC	6	6
	24" OC	4	4

164 MPH WIND - EXPOSURE "D" TYPICAL
E = NAIL SPACING AT PANEL EDGES, INCHES.
F = NAIL SPACING AT INTERMEDIATE SUPPORTS IN THE PANEL FIELD, INCHES.

TABLE S601.1 - WALL SHEATHING AND CLADDING REQUIREMENT - WIND LOAD EXP "D"

SHEATHING LOCATION	RAFTER / TRUSS SPACING	E F	
		MAX NAIL SPACING FOR 8d COMMON NAILS OR 10d BOX NAILS (INCHES OC)	
INTERIOR ZONE	12" OC	6	12
	16" OC	6	12
	24" OC	6	6
PERIMETER EDGE ZONE	12" OC	6	12
	24" OC	6	6

164 MPH WIND - EXPOSURE "D" TYPICAL
E = NAIL SPACING AT PANEL EDGES, INCHES.
F = NAIL SPACING AT INTERMEDIATE SUPPORTS IN THE PANEL FIELD, INCHES.

DAMMON ENGINEERING, INC.
LOUISIANA & MISSISSIPPI

Chief Engineer: Brian Mistich, PE
554 Old Spanish Trail
Slidell, LA 70458
www.dammonengineering.com
info@dammonengineering.com
PH: 985-649-5832

STATE OF LOUISIANA
BRIAN A. MISTICH
License No. 31811
Professional Engineer

ALBERT CUITTO

BOAT HOUSE PLAN

LOT 16
2715 CHIEF MENTEUR HWY
IRBIA ORLEANS, LOUISIANA 70394
JOB No: 2024
DATE: 05-02-2024
DRAWN BY: DD/KJK
CHECKED BY: CKD

SHEET TITLE:
TYPICAL CONNECTION
DETAILS, SCHEDULES, AND
NOTES

DRAWING NUMBER:
S107

SHEET No: 9 of 13

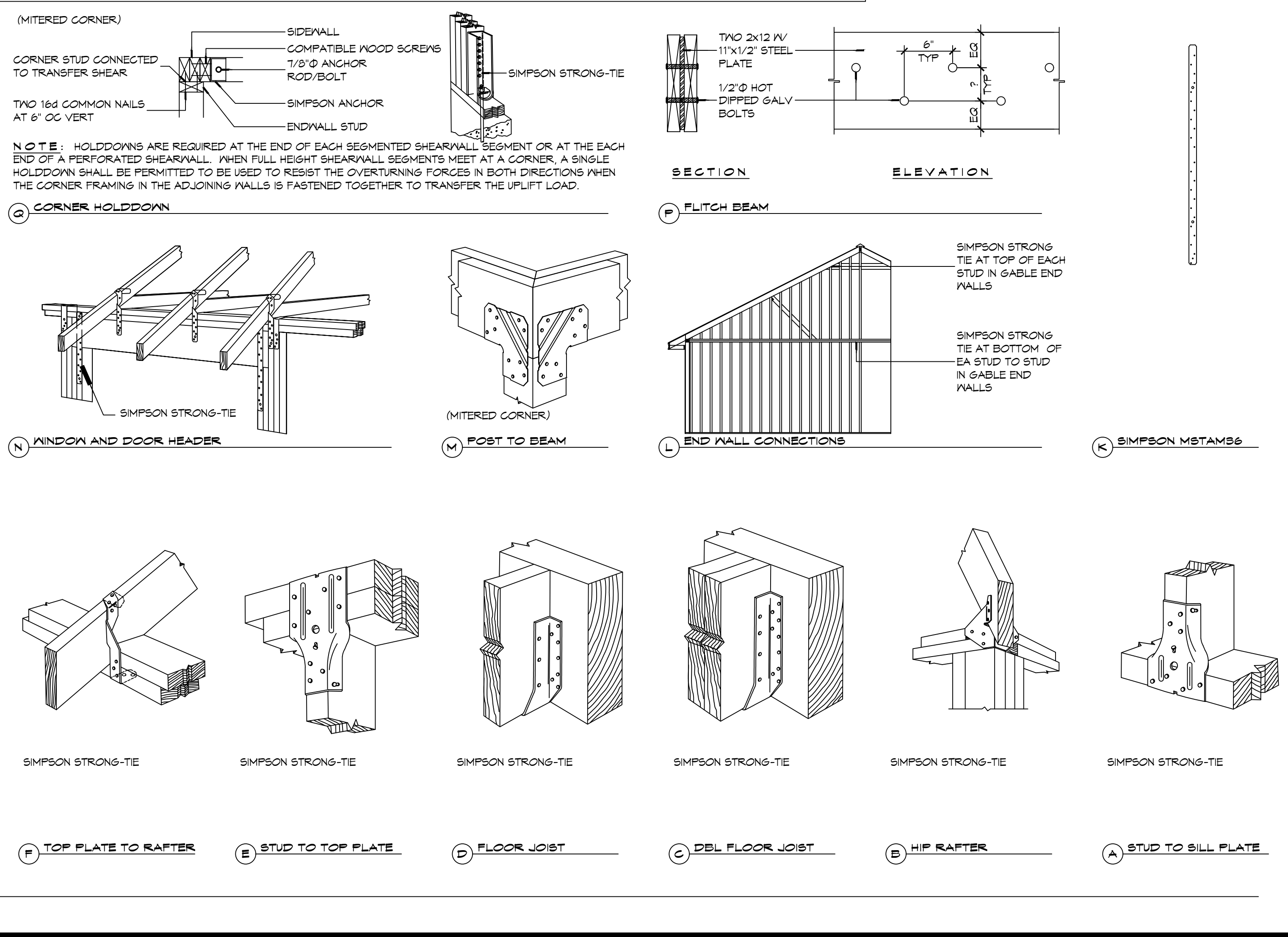
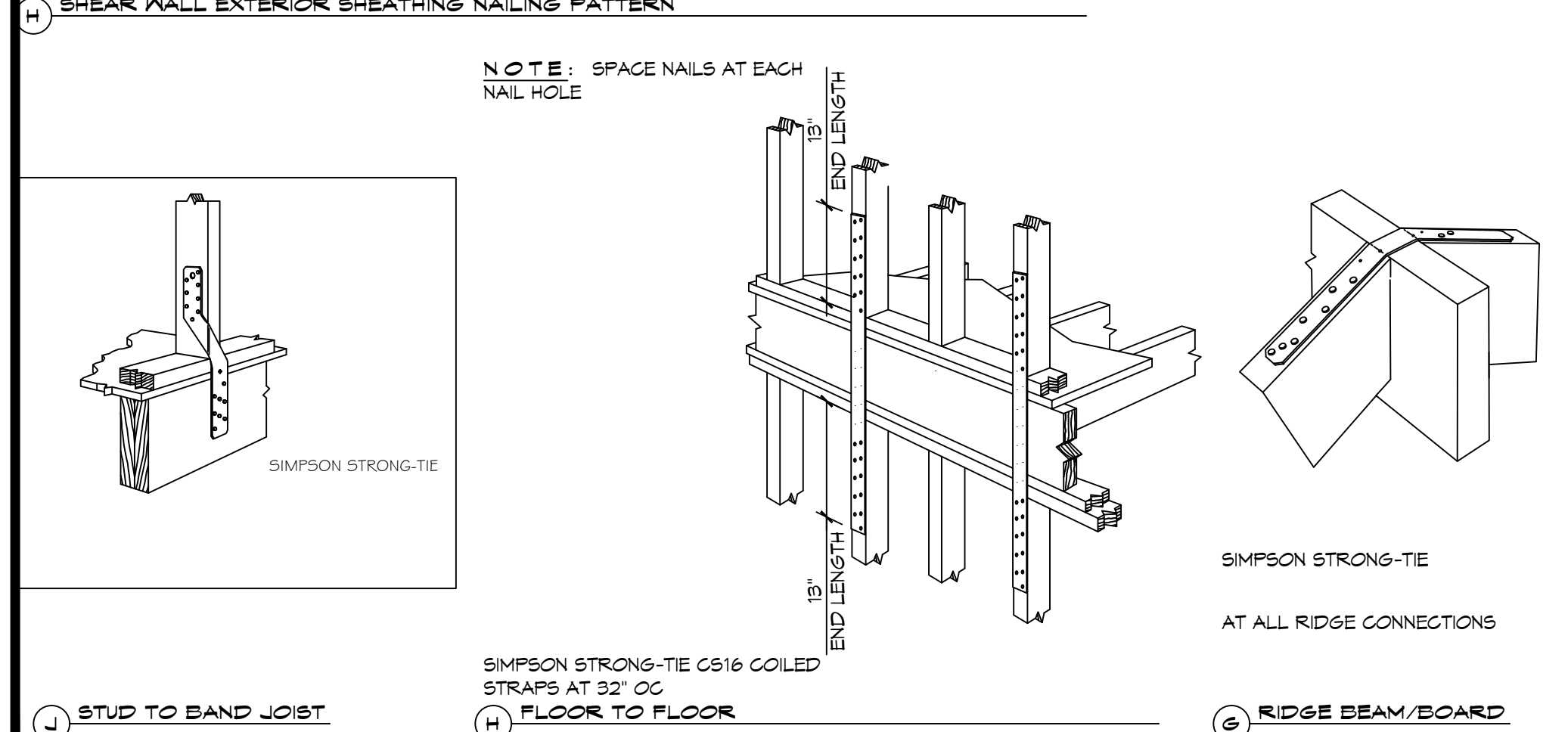
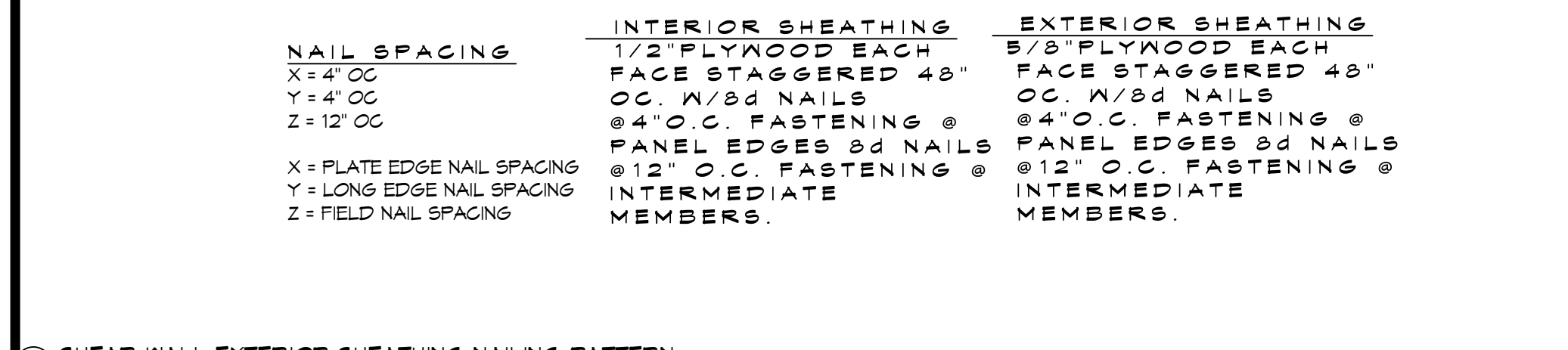
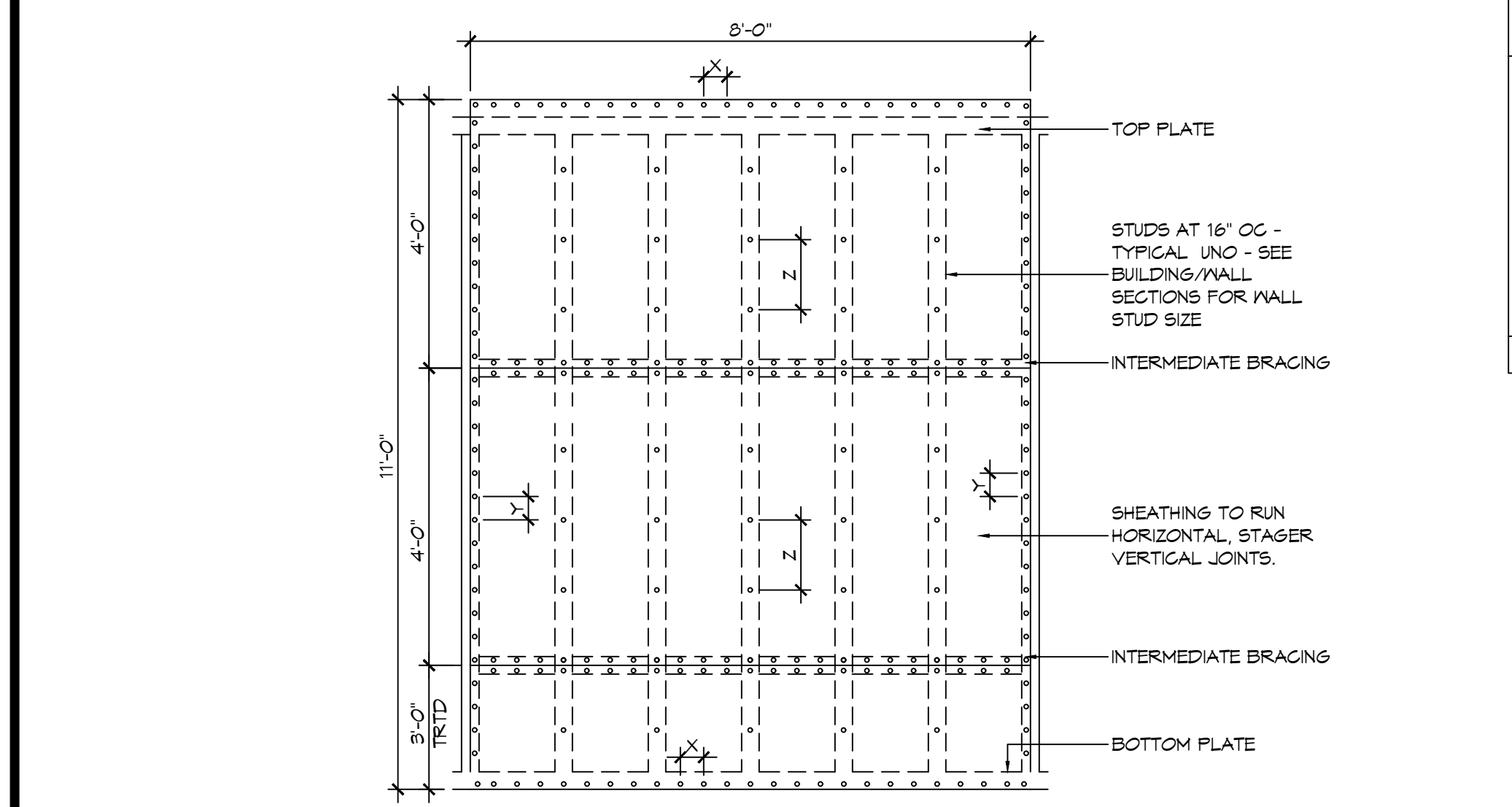

TYPICAL CONNECTION DETAILS
SCALE: NTS

