

DESIGN CRITERIA:

THE CONSTRUCTION FOR SAID RESIDENCE, WHERE BASIC WIND SPEED IS 130 MILES PER HOUR, WIND EXPOSURE ZONE C, IS DESIGNED IN ACCORDANCE WITH: AMERICAN FOREST AND PAPER ASSOCIATION (AF&PA) WOOD FRAME CONSTRUCTION MANUAL FOR ONE AND TWO FAMILY DWELLINGS (WFCM) 2001 EDITION AS WELL AS THE INTERNATIONAL RESIDENTIAL CODE (IRC) 2009 EDITION

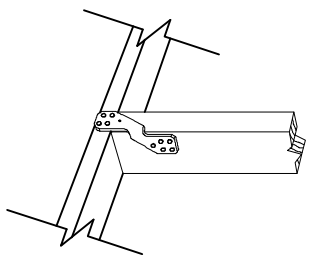

SECTION
SCALE: N.T.S.

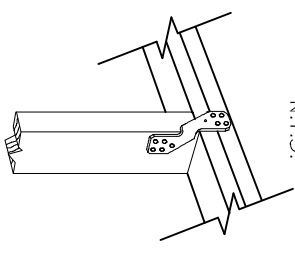
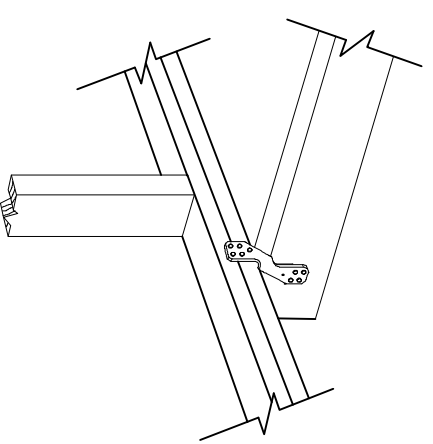
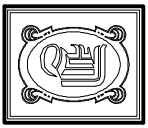

DAMMON ENGINEERING, INC.

CHIEF ENGINEER
DAMON, P.E.
CHIEF ARCHITECT
ROBERT WILDSE

554 OLD SPANISH RAIL
SUITE 1A, 70450
OFFICE 505.648.5832
FAX 505.641.1250
WWW.DAMON-ENGINEERING.COM
DAMON@DAMON-ENGINEERING.COM

ARCHITECTURE
ENGINEERING
STUDIOS
PLANNING
INVESTIGATION
EXPERT WITNESS

16 UNIT
STORAGE
BLDG.

GRAND MARCHAND
APARTMENTS
4754

PONCHARTRAIN DR
SLIDELL, LA

STRAP
LOCATIONS

REV.	
SCALE:	AS NOTED
JOB#:	
DATE:	03-05-12
SHEET	1