

**Front**

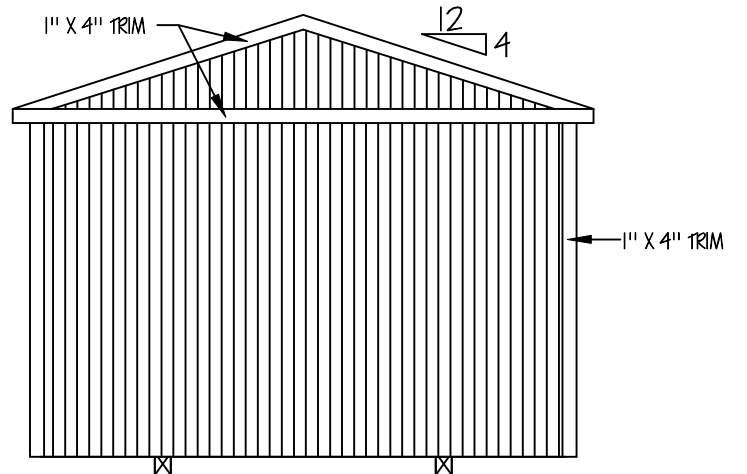

**Rear**

ANCHORS: IRON ROOF DOUBLE HEAD DOUBLE HELIX EARTH ANCHORS. 30" LONG BY 3/4" W/ 2-4" HELIX FOR SOIL CLASS 2'  
 1-1/4" FRAME TIE GALVANIZE STRAP WITH BUCKLE AND SLOTTED BOLTS CENTERED BETWEEN EACH PIER.  
 GIRDERS: TWO REQUIRED FOR 8' and 10' BUILDINGS AND FOUR REQUIRED FOR 12', 14' and 16' BUILDINGS.  
 BUILDINGS 14'-0" AND 16'-0" WIDE, STUDS 16" O.C.

MEASURES SHALL BE TAKEN DURING CONSTRUCTION TO INSURE THAT ONLY WORKMANSHIP OF THE HIGHEST QUALITY IS PERFORMED AND THAT ONLY THE BEST MATERIALS AND PRACTICES OF CONSTRUCTION ARE USED FOR A QUALITY AND SOUND BUILDING.

NOTE: THE UTILITY FLOORING, WALLS AND ROOF ARE DESIGNED TO COMPLY WITH THE 2012 INTERNATIONAL BUILDING AND INTERNATIONAL RESIDENTIAL CODES. THEY ARE NOT INTENDED FOR RESIDENTIAL USAGE 'ALL' STATE AND LOCAL CODES MUST BE MET INCLUDING BUT NOT LIMITED TO SIZES, OPENINGS, CEILING HEIGHTS, ELECTRICAL, PLUMBING ETC.

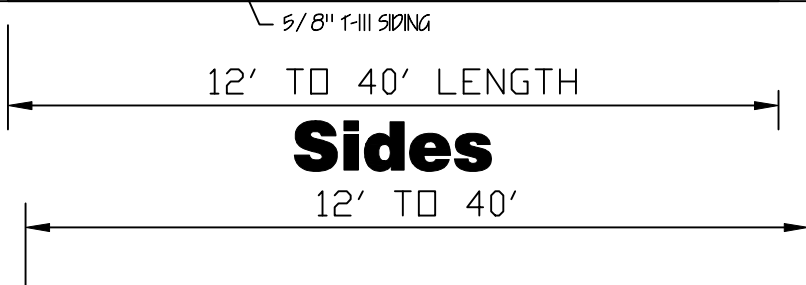

**Sides**

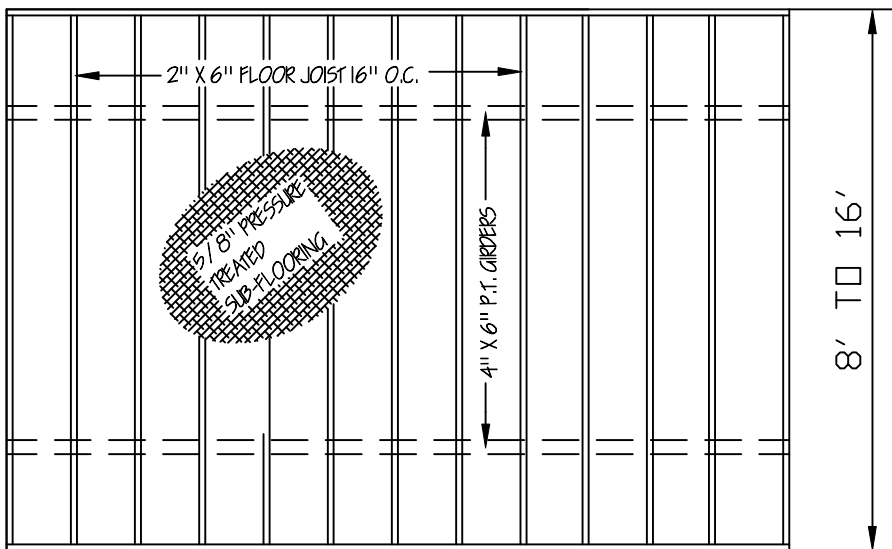

**FLOOR FRAMING**

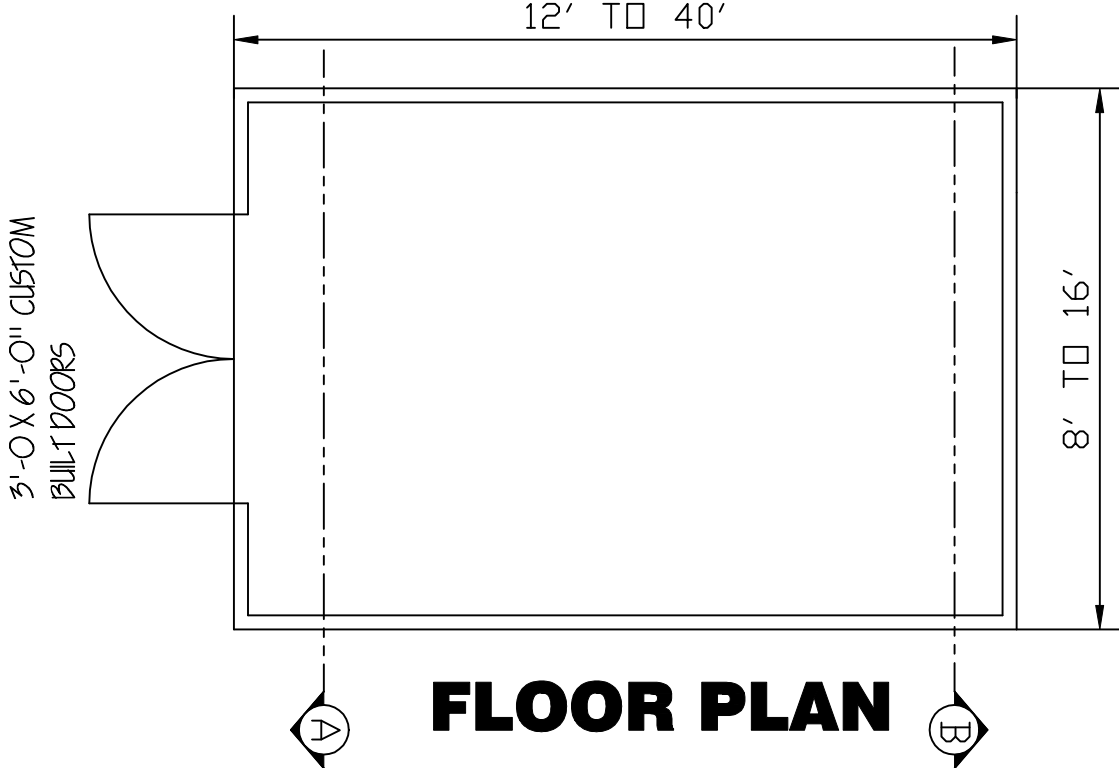

**FLOOR PLAN**

**ENGINEERS' NOTES:**

1. FOUNDATIONS PIERS, TIE-DOWNS AND ANCHORS SHALL MEET THE REQUIREMENTS OF THE "PERMANENT FOUNDATIONS GUIDE OF MANUFACTURED HOUSING" AS PUBLISHED BY HUD IN SEPTEMBER 1996, AND THE HUD HANDBOOK 4145.1 REV. 2.
2. NO FIELD SUPERVISION PROVIDED UNDER THIS SEAL.
3. NO ADMINISTRATION PROVIDED UNDER THIS SEAL.

**Utility**

WIND CERTIFICATION  
 WIND EXPOSURE CATEGORY 'C'  
 BASIC WIND SPEED (3 SECOND GUST) 150 M.P.H.

MISSISSIPPI-LOUISIANA

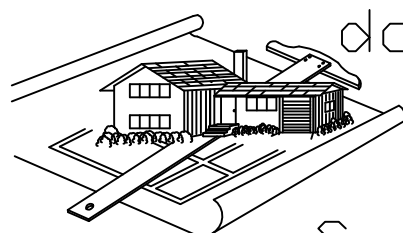

doug's  
 plan  
 Service

4210 Stewart Lane  
 Perkinston, MS 39573  
 228/255-5259

GRACELAND PROPERTIES LLC  
 P.O. BOX 665  
 CUNNINGHAM, KY 42035

Copyright (C) 2008 by Graceland Properties LLC  
 All Rights Reserved, including the rights of reproduction in whole or in part in any form.