

DRAINAGE PLAN
SCALE 1"=20'-0"

NO ON-SITE DETENTION SHALL BE REQUIRED. WATERSHED SHALL DRAIN INTO LAKE.

- DRAINAGE NOTES**
- 1) DRAIN PIPE & FITTINGS SHALL BE POLYVINYL CHLORIDE PLASTIC PIPE, WEETING CLASS 100 C-900 PVC
 - 2) ELEVATIONS SHOWN ARE NGVD
 - 3) FIELD VERIFY ALL ELEVATIONS AND DRAINAGE SYSTEM PLACEMENT PRIOR TO START OF WORK
 - 4) CLEAN OUT ALL DITCHES AND CULVERTS PRIOR TO START OF WORK TO ENSURE PROPER DRAINAGE
 - 5) HCP PARKING AREA SHALL BE LEVEL, ELEV. 9.28

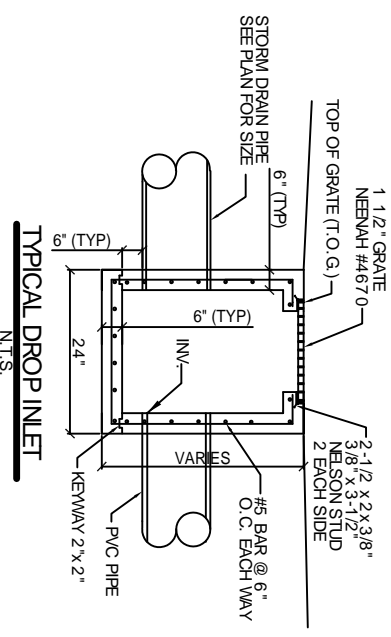
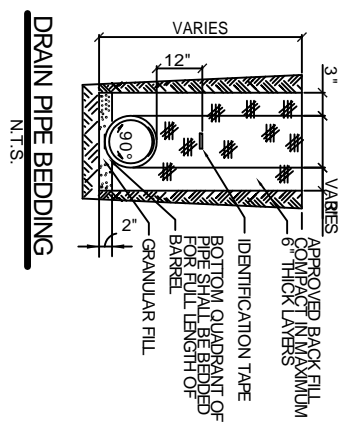

- LEGEND**
- PROPERTY LINE
 - - - SETBACK
 - NEW BUILDING OUTLINE
 - NEW DRAINAGE LINE W/ FLOW DIRECTION
 - EXISTING DRAINAGE LINE W/ FLOW DIRECTION
 - - - SILT FENCE
 - X 0.0' - EXISTING ELEVATION
 - 0.0' - NEW ELEVATION
 - TC 0.0' 0' - TOP OF CONCRETE CURB
 - 0.0' - CATCH BASIN TOP OF GRATE
 - 0.0' - INVERT ELEVATION
 - @ 0.0' - SLOPE LINE
 - ▣ NEW CATCH BASIN

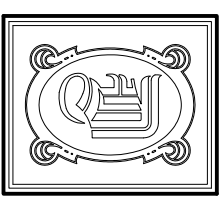

DAMMON ENGINEERING, INC.
 CHIEF ENGINEER
 EMMETT DAMMON, P.E.
 CHIEF ARCHITECT
 ROBERT WILTSE

1095 FLORIDA AVENUE
 SUDELL, LA. 70458
 OFFICE: 985-649-5832
 FAX: 985-641-5950

WWW.DAMMONENGINEERING.COM
 EMAIL: DAMMONENG@BELLSOUTH.NET

ARCHITECTURE
 ENGINEERING
 STUDIES
 PLANNING
 INVESTIGATION
 EXPERT WITNESS

NEW RESTAURANT

CHRISTIANO'S
 RISTORANTE
 OAK HARBOR BLVD
 LOT 29
 SUDELL, LA 70458

DRAINAGE PLAN

REV: _____
 SCALE AS NOTED
 JOB#: 1955
 DATE: 5-16-08
 SHEET 3