

241-73  
4

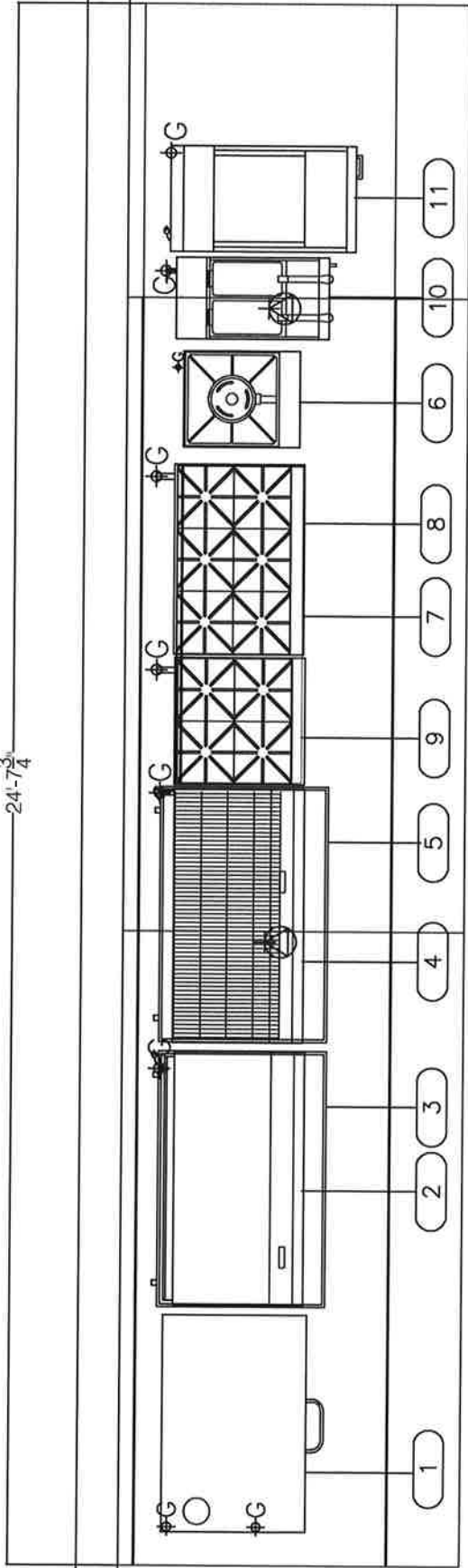

13

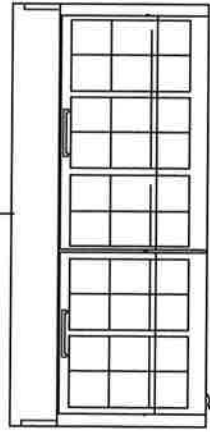

12

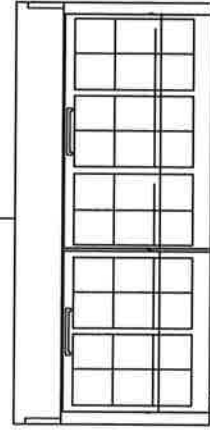

# E Q U I P M E N T S C H E D U L E

Item No	Qty	Equipment Category	Model Number	Manufacturer
1	1	Oven, Baking & Roasting, Gas	2324	Peerless
2	1	Griddle, Gas	GGT-48H / <i>TM 6743</i>	APW Wyott / <i>TARRANTS</i>
3	1	Refrigerator, Shorty	TRCB-48	True Food Service
4	1	Broiler, Under-Fired/Gas	GCB-48H / <i>TRCB 48</i>	APW Wyott / <i>TARRANTS</i>
5	1	Refrigerator, Shorty	TRCB-48	True Food Service
6	1	Stove, Bakers/Confectioners/Stock Pot	SR-18-R-SS / <i>SPR 1-2</i>	Town Food Service Equipment / <i>Supera</i>
7	1	Stand, Equipment	EG-245	Advance Tabco
8	1	Hot Plate, Gas	GHP-6H / <i>LLC 6CT-2</i>	APW Wyott / <i>Supera</i>
9	1	Hot Plate, Gas	GHP-4H / <i>LLC 4CT-2</i>	APW Wyott / <i>Supera</i>
10	1	Fryer, Deep Fat, Gas	SR142G	Dean
11	1	Fryer, Deep Fat, Gas	SR162G	Dean <i>EXISTING</i>
12	1	Refrigerator, Sandwich/Salad Prep	TFP-72-30M / <i>MPT 3A-1</i>	True Food Service / <i>Supera</i>
13	1	Refrigerator, Sandwich/Salad Prep	TFP-72-30M / <i>MPT 3A-1</i>	True Food Service / <i>Supera</i>

# MAXIMIZER

## Multideck Bake Ovens

### General Features:

- Quality Construction for long life
- Time proven Over 90 years of design life
- More for less More sq. inches of cooking space for each precious foot of kitchen space. More oven for your investment dollar.
- Large capacity Four & eight pan models
- Energy efficient New energy-saving burner system
- Aluminized interior
- 250° - 550° Bake thermostat (standard)
- 650° Pizza thermostat available
- Pizza stones available
- Versatile Perfect for a variety of baking needs
- Easily serviceable All controls can be replaced from the front of the unit
- Warranty One year parts and labor
- Power Gas only



MODEL 2324B  
2348B  
2324M  
2348M



**GAS ONLY**

### MORE FOR LESS

More Cooking Space per Floor Space  
More Cooking Capacity per Sales Dollar  
More Performance per Gas Dollar

**Peerless**  
Commercial and Industrial Ovens

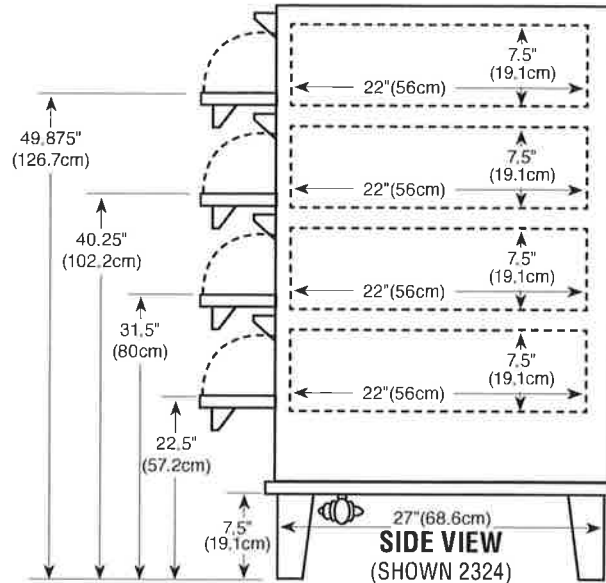
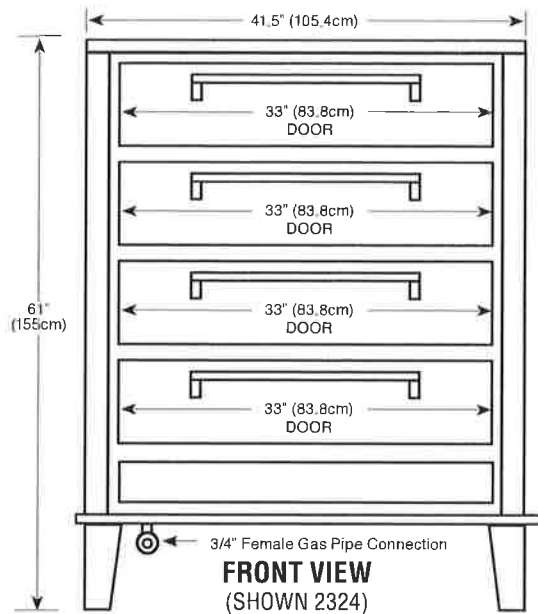

MODEL #	DECK			BODY			MAX BTU INPUT	SHIPPING WEIGHT	CAPACITY
	W	D	H	W	D	H			
2324	33" 83.8cm	22" 56cm	7.5" 19.1cm	41.5" 105.4cm	27" 68.6cm	61" 155cm	60,000	536lbs 243kg	EIGHT 16" PIZZAS
2348	42" 106.7cm	32" 81.3cm	7.5" 19.1cm	50.5" 128.3cm	37" 94cm	61" 155cm	96,000	720lbs 327kg	SIXTEEN 16" PIZZAS



Adjustable Legs

### Durable Construction

The "2300 series" ovens are construction on a 14-gauge, hot-rolled base with prime 20-gauge, cold-rolled top and sides. The interior is made of *Armco Type-1, 20-gauge, aluminized steel*. The shelves are made of 16-gauge, aluminized steel.

### Energy Efficiency

The Peerless multideck ovens are equipped with highly *efficient steel tubular burners*. The 2324, four-pan oven has four, tubular burners that supply 60,000 BTU's for great performance and fast recovery. The 2348, eight-pan oven is equipped with six, tubular burners that supply 90,000 BTU's. All units are equipped with *modern safety pilots and thermostats*. Our pizza oven version comes with separate on/off valve.

### Space Savers

Because our unique construction and the fact the controls are under the door, the Peerless multideck ovens are by far the most space conservative ovens on the market today. The 2324, four-pan oven requires only 41.5" while the eight-pan requires only 51.5". This frees up valuable kitchen and/or hood space.

### Capacity

Each of the four decks of the 2324, four-pan oven measure 33"x22"x7.5". They can easily handle a 18"x26" bun pan, two 12" pizzas or a variety of other products. The 2348, eight-pan oven has four, large 42"x32"x7.5" decks capable of holding eight 18"x26" bun pans, twenty-four 12" pizzas, or sixteen 16" pizzas, all using only 51.5" of space.



Adjustable Dampers at each deck

**Peerless**  
Commercial and Industrial Ovens



Foodservice Equipment

Job \_\_\_\_\_ Item# \_\_\_\_\_

**Manual Gas Griddles**  
 TMGM24, TMGM36, TMGM48  
**Gas Griddles with Thermostatic Controls**  
 TMGT24, TMGT36, TMGT48

**Standard Features:**

- NEW Ultra smooth 3/4" thick polished steel plate.
- Manual griddle designed with 1/4 turn manual control and standing pilot.
- Thermostat griddles feature throttling thermostat that adjust from 150°- 450°F.
- Available in 24", 36" and 48" widths.
- High performance 20,000 BTU aluminized steel "U" shape burner every 12".
- Spatula wide 3-1/4" front grease trough and grease chute.
- Stainless steel front panel, bull nose and grease drawer.
- 3/4" rear gas connection and universal pressure regulator supplied. Field convertible to LP with orifices included.
- 4" nickel plated steel legs.



TMGM36

**Applications:**

The Toastmaster Countertop Gas Griddles are the most economical and flexible Countertop Griddles in the food service industry. They offer unsurpassed performance, combining a proven control system with Toastmaster quality and durability. Available in three different widths - 24", 36" and 48".

**General Information:**

Stainless steel front including top rail, with aluminized steel rear and sides, with 4-3/8" high rear and side splash guards and full width stainless steel grease trough and easy to access grease drawer.

Gas units have 3/4" polished rolled steel plate.

**Warranty**

Toastmaster griddles are covered by Toastmaster's one year parts and labor warranty.



Toastmaster® 10 Sunnen Dr, St. Louis MO 63143 • www.toastmastercorp.com  
 Telephone: 1-314-678-6347 • Fax: 1-314-781-3636

# Manual Gas Griddles

## TMGM24, TMGM36, TMGM48

### Gas Griddles with Thermostatic Controls

#### TMGT24, TMGT36, TMGT48

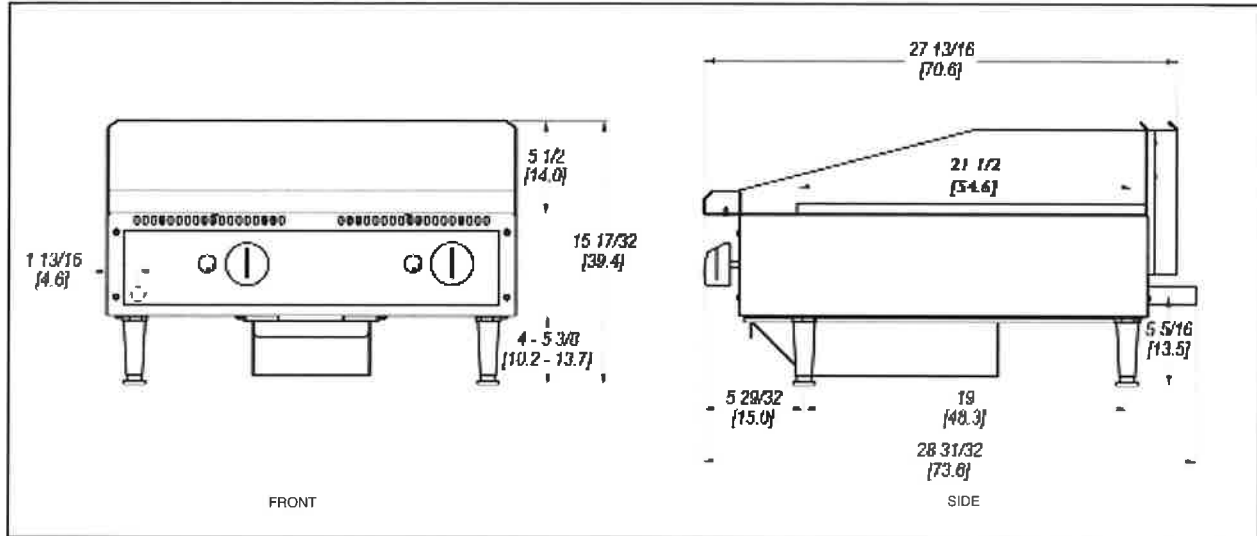

Model Number	TMGM24	TMGM36	TMGM48	TMGT24	TMGT36	TMGT48
Dimensions	24" W x 15-17/32" H x 27-13/16" L	36" W x 15-17/32" H x 27-13/16" L	48" W x 15-17/32" H x 27-13/16" L	24" W x 15-17/32" H x 27-13/16" L	36" W x 15-17/32" H x 27-13/16" L	48" W x 15-17/32" H x 27-13/16" L
Number of Controls	2	3	4	2	3	4
BTU	40,000	60,000	80,000	40,000	60,000	80,000
Griddle Plate Thickness	3/4"	3/4"	3/4"	3/4"	3/4"	3/4"
Cook Zone Size	24"	36"	48"	24"	36"	48"
Installed Weight (lbs.) (kg)	148 lbs. (67.3)	221 lbs. (100.5)	295 lbs. (134.1)	148 lbs. (67.3)	221 lbs. (100.5)	295 lbs. (134.1)
Shipping Weight (lbs.) (kg)	158 lbs. (71.8)	236 lbs. (107.3)	315 lbs. (143.2)	158 lbs. (71.8)	236 lbs. (107.3)	315 lbs. (143.2)

**Typical Specifications:**

Gas griddles are constructed with a stainless steel front panel and reinforced wall aluminized steel side panels. Griddle plate is 3/4" (1.9 cm) thick steel plate with 4-3/8" (11.1 cm) high tapered wrap-around stainless steel splash guard. Unit has 3-1/4" (8.3 cm) wide front grease trough with grease chute and a 4-1/2 qt. (4.257 L) stainless steel grease drawer. Unit is equipped with a 20,000 BTU aluminized steel burner for every 12" (30.5 cm) of width and is controlled by a either manual control valve or throttling thermostat. Valve knobs are protected by a stainless steel bull nose front. A standing pilot is provided. Griddles are supplied with 4" (10.2 cm) high die cast nickel-plated legs with a 1-3/8" (3.5 cm) adjustment. Gas connection is a 3/4" (1.3 cm) N.P.T. male with a convertible pressure regulator. Units are approved for installation within 6" (15.2 cm) of combustible and non-combustible surfaces and are UL Gas Certified and UL Sanitation listed. Printed in the U.S.A.

INTENDED FOR COMMERCIAL USE ONLY. NOT FOR HOUSEHOLD USE.

TM108/1014



Toastmaster, in line with its policy to continually improve its product, reserves the right to change materials or specifications without notice. Such revisions do not entitle the buyer to corresponding changes, improvements, additions, or replacements for previously purchased equipment.



Toastmaster® 10 Sunnen Dr, St. Louis MO 63143 • www.toastmastercorp.com  
Telephone: 1-314-678-6347 • Fax: 1-314-781-3636



Foodservice Equipment

Job \_\_\_\_\_ Item# \_\_\_\_\_

## Lava Rock Gas Charbroilers

*TMLC24, TMLC36, TMLC48*

## Radiant Style Gas Charbroilers

*TMRC24, TMRC36, TMRC48*

### Standard Features:

- Available in 24", 36" and 48" widths.
- Stainless steel front including top rail.
- 30,000 BTU per foot.
- Aluminized steel drip pan, rear and sides.
- Adjustable flame per 12" cooking zone.
- Reversible double branding grates.
- Narrow grates have drain channels.
- Full width water pan for easy cleaning.
- Radiant units are designed with stainless steel radiantss.
- Lava rock units include 1 bag of lava rock per 12" section.
- 4" nickel plated steel legs.
- 3/4" rear gas connection.



TMLC36

### Applications:

Toastmaster's Countertop Gas Charbroilers are the most economical and flexible countertop charbroiler in the food service industry. They offer unsurpassed performance, combining a proven control system with Toastmaster quality and durability. Available in three different sizes - 24", 36" and 48".

### General Information:

Stainless steel front includes top rail, with aluminized steel rear and sides. Full width water pan,

reversible grates and 30,000 BTU per foot burners.

### Warranty:

Toastmaster charbroilers are covered by Toastmaster's one year parts and labor warranty.



T103/0119

**Toastmaster**® 10 Sunnen Dr, St. Louis MO 63143 • [www.toastmastercorp.com](http://www.toastmastercorp.com)  
Toll Free: 1-800-264-7827 • Telephone: 1-314-781-2777 • Fax: 1-314-781-3636

# Lava Rock Gas Charbroilers

*TMLC24, TMLC36, TMLC48*

# Radiant Style Gas Charbroilers

*TMRC24, TMRC36, TMRC48*

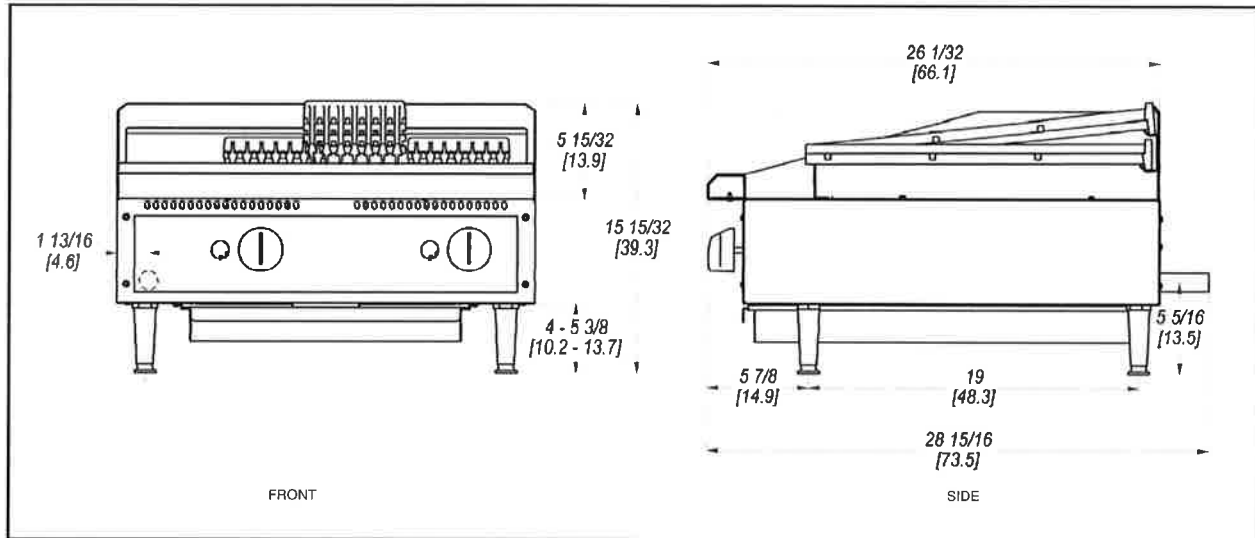

Model Number	TMLC24	TMLC36	TMLC48	TMRC24	TMRC36	TMRC48
<b>Dimensions</b>	24" W x 15-15/32" H x 26-1/32" L	36" W x 15-15/32" H x 26-1/32" L	48" W x 15-15/32" H x 26-1/32" L	24" W x 15-15/32" H x 26-1/32" L	36" W x 15-15/32" H x 26-1/32" L	48" W x 15-15/32" H x 26-1/32" L
<b>Number of Controls</b>	2	3	4	2	3	4
<b>BTU</b>	60,000	90,000	120,000	60,000	90,000	120,000
<b>Griddle Plate Thickness</b>	5/8"	5/8"	5/8"	5/8"	5/8"	5/8"
<b>Cook Zone Size</b>	24"	36"	48"	24"	36"	48"
<b>Installed Weight (lbs.) (kg)</b>	153 lbs. (69.5)	192 lbs. (87.2)	299 lbs. (135.7)	153 lbs. (69.5)	192 lbs. (87.2)	299 lbs. (135.7)
<b>Shipping Weight (lbs.) (kg)</b>	186 lbs. (84.4)	230 lbs. (104.4)	350 lbs. (158.9)	186 lbs. (84.4)	230 lbs. (104.4)	350 lbs. (158.9)

**Typical Specifications:**

Gas charbroilers are constructed with stainless steel front panel and reinforced aluminized steel side panels. Every 12" (30.5 cm) an individually controlled, corrosion resistant, burner supplies up to 30,000 BTU/hr (8.8Kw) of heat. Cooking surface is heavy-duty cast iron with two grid mark widths on opposite sides. Cooking surface can be adjusted for level or slanted grilling. Standing pilot is provided. A full width water pan is provided. Control knobs are protected by a stainless steel bull nose front. Char-broilers are supplied with 4" (10.2 cm) high die cast nickel plated legs with a 1-3/8" (3.5 cm) adjustment. Gas connection is 3/4" N.P.T. (male) and a convertible regulator is supplied as well as a kit for conversion to LP gas. Units are UL Gas Certified for U.S. and Canada. UL listed to NSF4 standard. Printed in the U.S.A.

**INTENDED FOR COMMERCIAL USE ONLY. NOT FOR HOUSEHOLD USE.**



Toastmaster, in line with its policy to continually improve its product, reserves the right to change materials or specifications without notice. Such revisions do not entitle the buyer to corresponding changes, improvements, additions, or replacements for previously purchased equipment.



**Toastmaster®** 10 Sunnen Dr, St. Louis MO 63143 • [www.toastmastercorp.com](http://www.toastmastercorp.com)  
Toll Free: 1-800-264-7827 • Telephone: 1-314-781-2777 • Fax: 1-314-781-3636

 <b>TRUE FOOD SERVICE EQUIPMENT, INC.</b> 2001 East Terra Lane • O'Fallon, Missouri 63366-4434 • (636)240-2400 Fax (636)272-2408 • Toll Free (800)325-6152 • Intl Fax# (001)636-272-7546 Parts Dept. (800)424-TRUE • Parts Dept. Fax# (636)272-9471 • www.truemfg.com	Project Name: _____ Location: _____ Item #: _____ Qty: _____ Model #: _____	AIA #
		SIS #
<b>Model: TRCB-48</b>		
<b>Chef Base:</b> <i>Drawered Refrigerator</i>		

**TRCB-48**



- ▶ True's refrigerated chef bases are designed with enduring quality that protects your long term investment.
- ▶ Designed using the highest quality materials and components to provide the user with colder product temperatures, lower utility costs, exceptional food safety and the best value in today's food service marketplace.
- ▶ Oversized, environmentally friendly (134A) forced-air refrigeration system holds 33°F to 38°F (.5°C to 3.3°C).
- ▶ Cabinet top is one piece, heavy duty reinforced stainless steel. Drip resistant "V" edge protects against spills. Supports up to 717 lbs. (326 kg).
- ▶ All stainless steel front, top and sides. Matching aluminum finished back.
- ▶ Each drawer accommodates two (2) full size 12"L x 20"W x 4"D (305 mm x 508 mm x 102 mm) food pans (sold separately).
- ▶ Heavy-duty stainless steel drawer slides and rollers. Removable without tools for easy cleaning.
- ▶ Foamed-in-place using Ecomate. A high density, polyurethane insulation that has zero ozone depletion potential (ODP) and zero global warming potential (GWP).



**ROUGH-IN DATA**

Specifications subject to change without notice. Chart dimensions rounded up to the nearest 1/8" (millimeters rounded up to next whole number).

Model	Drawers	Cabinet Dimensions (inches) (mm)			HP	Voltage	Amps	NEMA Config.	Cord Length (total ft.) (total m)	Crated Weight (lbs.) (kg)
		L	D†	H*						
TRCB-48	2	48 3/8 1229	32 1/8 816	20 3/8 518	1/5 1/3	115/60/1 230-240/50/1	5.4 3.2	5-15P ▲	7 2.13	325 148

† Depth does not include 1" (26 mm) for rear bumpers. \* Height does not include 5" (127 mm) for castors or 6" (153 mm) for optional legs. ▲ Plug type varies by country.

	<b>APPROVALS:</b> _____ _____	<b>AVAILABLE AT:</b> _____ _____
7/15 Printed in U.S.A.		

Model:  
**TRCB-48**

**Chef Base:**  
Drawered Refrigerator



**STANDARD FEATURES**

**DESIGN**

- True's commitment to using the highest quality materials and oversized refrigeration systems provides the user with colder product temperatures, lower utility costs, exceptional food safety and the best value in today's food service marketplace.

**REFRIGERATION SYSTEM**

- Factory engineered, self-contained, capillary tube system using environmentally friendly (CFC free) 134A refrigerant.
- Oversized, factory balanced refrigeration system with guided airflow to provide uniform product temperatures.
- Extra large evaporator coil balanced with higher horsepower compressor and large condenser; maintains cabinet temperatures of 33°F to 38°F (.5°C to 3.3°C) for the best in food preservation.
- Sealed, cast iron, self-lubricating evaporator fan motor(s) and larger fan blades give True chef base units a more efficient, low velocity, high volume airflow design. This unique design ensures faster temperature recovery and shorter run times in the busiest of food service environments.
- Condensing unit accessed from behind side grill; slides out for easy maintenance.

**CABINET CONSTRUCTION**

- Exterior - stainless steel front, top and sides. Matching aluminum finished back.
- Interior - attractive, NSF approved, white aluminum liner. Stainless steel floor with coved corners.

- Insulation - entire cabinet structure and drawer facings are foamed-in-place using Ecomate. A high density, polyurethane insulation that has zero ozone depletion potential (ODP) and zero global warming potential (GWP).
- 4" (102 mm) diameter plate castors - locks provided on front set.
- Cabinet top is one piece, heavy duty reinforced 300 series stainless steel. Drip resistant "V" edge protects against spills. Supports up to 717 lbs. (326 kg).

**DRAWERS**

- Stainless steel exterior drawer facings and liners. Stainless steel drawer frames.
- Each drawer fitted with 12" (305 mm) long recessed handle that is foamed-in-place with a sheet metal interlock to ensure permanent attachment.
- Heavy-duty stainless steel drawer slides and rollers. Removable without tools for easy cleaning.
- Magnetic drawer gaskets of one piece construction, removable without tools for ease of cleaning.
- Each drawer accommodates two (2) full size 12"L x 20"W x 4"D (305 mm x 508 mm x 102 mm) food pans (sold separately).
- Drawers support a wide variety of incremental pan size configurations; each drawer standard with one (1) full length removable divider bar.

**MODEL FEATURES**

- Evaporator is epoxy coated to eliminate the potential of corrosion.
- Exterior digital temperature display.
- NSF-7 compliant for open food product.

**ELECTRICAL**

- Unit completely pre-wired at factory and ready for final connection to a 115/60/1 phase, 15 amp dedicated outlet. Cord and plug set included.



115/60/1  
NEMA-5-15R

**RECOMMENDED OPERATING CONDITIONS**

- Counter-top cooking equipment should be used in conjunction with the manufacturer supplied legs. Minimum clearance of 4" (102 mm) is required between bottom of cooking equipment heating element and the TRCB top. Failure to provide clearance voids manufacturer warranty.
- Installation of a heat shield is recommended for optimum performance (supplied by others).

**OPTIONAL FEATURES/ACCESSORIES**

Upcharge and lead times may apply.

- 230 - 240V / 50 Hz.
- 6" (153 mm) standard legs (1 set of 4 leg mounting plates required).
- 6" (153 mm) seismic/flanged legs (1 set of 4 leg mounting plates required).
- Heavy duty, 16 gauge top.
- Flat top (no marine edge).
- Additional size drawer divider bars.

**PLAN VIEW**

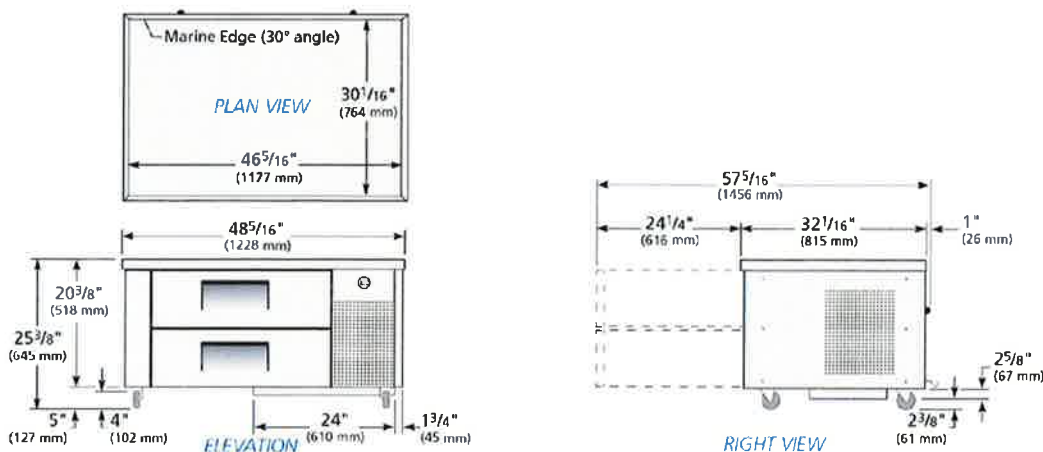

**WARRANTY\***  
Three year warranty on all parts and labor and an additional 2 year warranty on compressor. (U.S.A. only)

METRIC DIMENSIONS ROUNDED UP TO THE NEAREST WHOLE MILLIMETER  
SPECIFICATIONS SUBJECT TO CHANGE WITHOUT NOTICE

KCL	Model	Elevation	Right	Plan	3D	Back
	TRCB-48	TFQY191E	TFQY135S	TFQY191P	TFQY1913	

\*RESIDENTIAL APPLICATIONS: TRUE assumes no liability for parts or labor coverage for component failure or other damages resulting from installation in non-commercial or residential applications.

**TRUE FOOD SERVICE EQUIPMENT**

2001 East Terra Lane • O'Fallon, Missouri 63366-4434 • (636)240-2400 • Fax (636)272-2408 • Toll Free (800)325-6152 • Intl. Fax# (001)636-272-7546 • www.truefmfg.com



## Stock Pot Ranges

**Model Numbers: SPR1-2, SPR2-2**

### Supera® Gas Burner Stock Pot Ranges

Get your kitchen back with the Supera® Gas Burner Stock Pot Range and watch your kitchen transform into a well-oiled machine. These burners give you the potential for a whole new variety of food options without taking over your kitchen like a full-size commercial range. Your productivity drastically increases with only a little bit of countertop space being used. Integrate one of these units into your kitchen and then watch the magic happen.

## FEATURES

### Light it Up

The Supera® Gas Burner Stock Pot Range has adjustable stainless steel pilot igniters that are easily accessible from the front of the unit. The stainless steel knobs control both the inside and outside burners manually for everything you can cook up in your kitchen and the low profile height of this unit makes it very accommodating for small spaces. Did we mention the adjustable bullet feet? Limited kitchen space, I'd like you to meet your new best friend.

### Compact but Compelling

With its compact footprint this countertop friendly burner is perfect for simmering, warming and sautéing in an out of the way location while freeing up valuable real estate on your full commercial range so you can focus on faster paced items that need to make it out to the dining room fast. Any kitchen, large or small, can benefit from an extra burner or two for when busy is an understatement.

### Heavy Duty Design

The Supera® Gas Burner Stock Pot Range is built much like its larger brethren. It has a stainless steel exterior and features heavy duty cooking grates and cast iron burners. The wide and deep burner tines are perfect for pots both large and small. As if these stock pot ranges weren't accommodating enough, these natural gas units also come with a propane conversion kit.



SPR1-2



SPR2-2



### Features at a Glance:

- Durable stainless steel exterior
- Heavy duty cooking grates and cast iron burners
- 8" stainless steel legs with 2" adjustable bullet feet
- Stainless steel pilot igniters
- Natural gas unit that comes with a propane conversion kit
- Full width drip pan tray is removable for ease of cleaning
- Stainless steel dual knobs control outside and inside burners
- Compact design with low profile height
- Wide and deep burner accommodates large pot sizes



# Stock Pot Ranges – Product Specifications

Model Numbers: SPR1-2, SPR2-2

## Plan View

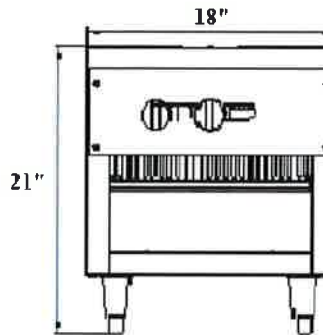

SPR1-2

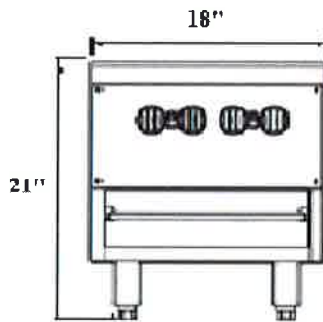
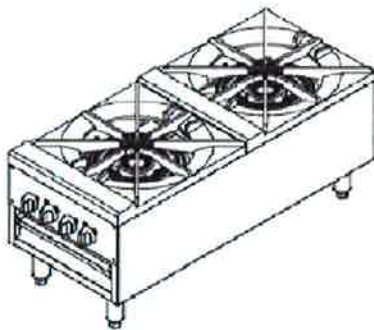
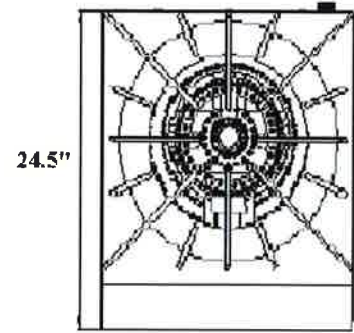

SPR2-2

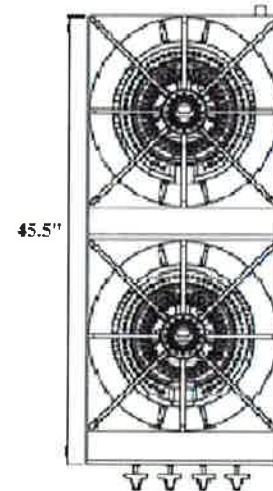

PRODUCT SPECIFICATIONS		
Model	SPR1-2	SPR2-2
Dimensions	21" x 18" x 24"	21" x 18" x 42"
Shipping Weight	115	210
Burner Type	Three-Ring Burner	
# of Burners	1	2
Power	Gas	
Total BTU	100,000	200,000





## LineCook Pro® Gas Hot Plates

**Model Numbers: LC2BCT-2, LC4BCT-2, LC6BCT-2**

### LineCook Pro®

The Supera® LineCook Pro® Series features a countertop cooking collection that measures the same in depth and clearance to line up for a seamlessly perfect cook's line. With hidden screws, stainless steel finishes and a straight-forward design, Supera's LineCook Pro® collection provides the efficient professional cooking experience you've been looking for and all without the hefty price tag!

### LineCook Pro® Gas Hot Plates

Restaurants, food trucks, caterers and all other foodservice operations can benefit greatly from the value packed in LineCook Pro® Hot Plates. Whether you need 2, 4 or 6 burners, Supera® Hot Plates will deliver high performance while taking up a minimal amount of countertop space.

## FEATURES

### Efficient Workspace

The heavy-duty, cast iron grates and stainless steel front edge of Supera® Hot Plates make for a highly efficient and spacious workspace. The grates and extended front edge sit at the same height so that you can easily maneuver pots and pans while cooking. Each grate is removable for easy cleaning and the cool-to-the-touch front edge keeps hands safe while providing a little extra workspace.

### High Quality Construction

Each Supera® Hot Plate is constructed of durable stainless steel with heavy-duty cast iron grates, stainless steel legs and a full length stainless steel drip pan. We take pride in providing premium, well-built cooking equipment that never sacrifices quality in order to deliver excellent value.

### High Performance Burners

Each burner pumps out 25,000 BTUs and evenly distributes the heat to the cast iron grates for superior heating and cooking. Aeration bowls retain and focus heat efficiently to the bottom of the pot/pan.



LC2BCT-2



LC4BCT-2



LC6BCT-2



### Features at a Glance:

- Available in 12" (2-burner), 24" (4-burner) and 36" (6-burner) widths
- Durable, attractive, stainless steel construction
- Front edge is cool to the touch for safe cooking
- Heavy-duty, cast iron grates for maximum heat distribution
- 25,000 BTUs per burner
- Adjustable pilots with front access
- Stainless steel legs have adjustable, non-skid feet
- Ships standard natural gas with propane conversion kit
- Octagonal burners provide even heat distribution
- Aeration bowls retain and focus heat efficiently to the bottom of the pot/pan
- Full-length, seamless drip pan
- Unit serviceable from the front



## Hot Plates – Product Specifications

Model Numbers: LC2BCT-2, LC4BCT-2, LC6BCT-2

### Plan View

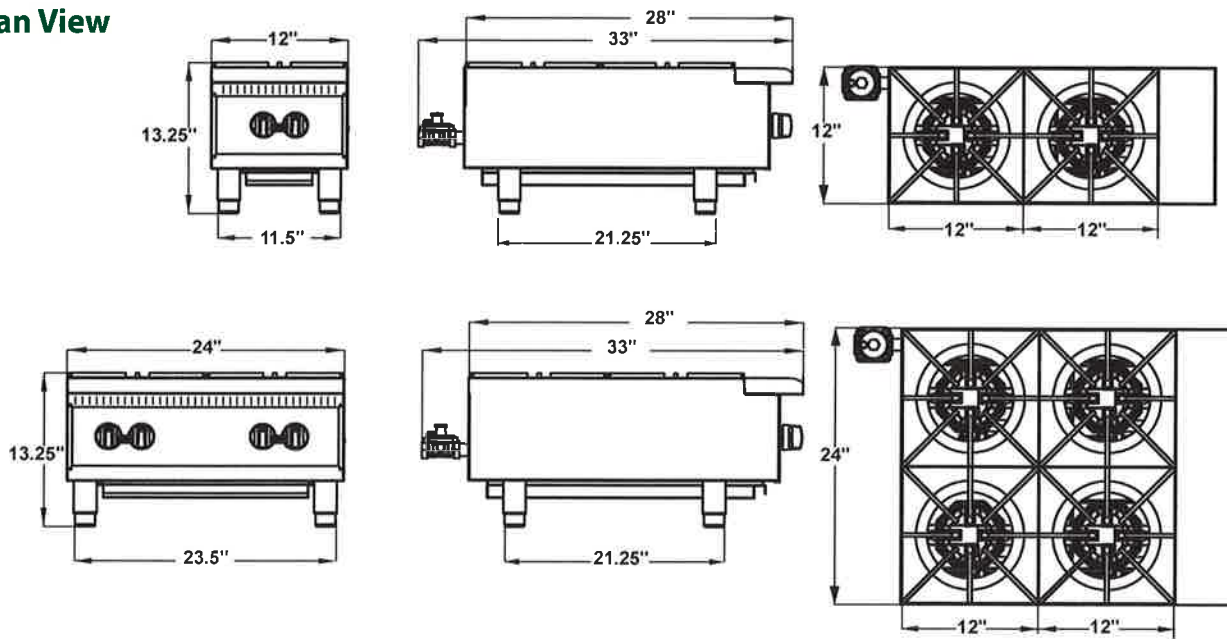

### DIMENSIONS & SHIPPING INFORMATION

**Please Note:** These items are shipped on a pallet and are crated for protection during LTL shipment. Overall Dimensions include the gas regulator located on the back of the unit.

Model	Footprint	Overall Dimensions	Weight	Shipping Dimensions	Shipping Weight
LC2BCT-2	21.25"L x 11.5"W (54 cm x 29.2 cm)	33"L x 12"W x 13.25"H (84 cm x 30.5 cm x 33.7 cm)	65 lbs (30 kg)	33" L x 17" W x 18"H (84 cm x 43 cm x 46 cm)	72 lbs (33 kg)
LC4BCT-2	21.25"L x 23.5"W (54 cm x 60 cm)	33"L x 24"W x 13.25"H (84 cm x 61 cm x 33.7 cm)	137 lbs (62 kg)	33" L x 29" W x 18"H (84 cm x 73 cm x 46 cm)	157 lbs (71 kg)
LC6BCT-2	21.25"L x 36.5"W (54 cm x 60 cm)	33"L x 36"W x 13.25"H (84 cm x 91.5 cm x 33.7 cm)	166 lbs (75 kg)	33" L x 41" W x 18"H (84 cm x 104 cm x 46 cm)	186 lbs (85 kg)

### SPECIFICATIONS

#### GAS REQUIREMENTS:

- Natural Gas or Liquid Propane (LP) Gas main supply required
- All units ship ready for Natural Gas. A LP conversion kit is included for converting to LP Gas. In order to avoid any warranty issues, conversion of your unit from Natural Gas to LP must be completed by an authorized Supera® service agent.

- 3/4" NPT gas connection
- 25,000 BTUs (per burner)
- One pilot light per burner

Model	Cooking Area	Controls	Number of Burners	BTUs (per burner)	Total BTUs
LC2BCT-2	24"D x 12"W	Manual	2	25,000	50,000
LC4BCT-2	24"D x 24"W	Manual	4	25,000	100,000
LC6BCT-2	24"D x 36"W	Manual	6	25,000	150,000





## Mega-Top Refrigerated Prep Tables

**Model Numbers: MTPT1R-1, MTPT2R-1, MTPT2R6-1, MTPT3R-1**

### Supera® Refrigeration

It's frustrating to pay more for features that should be standard. Supera® gets that and offers standard features like door locks, factory-installed casters and a 90° stay open door for every refrigeration unit. See how Supera's simple solutions can enhance the cold storage options in your restaurant!

## FEATURES

### Mega-Top

Supera® Mega-Top Refrigerated Prep Tables feature the extra storage capacity that busy foodservice environments need. The top-mounted ingredient rail features enough space for three rows of 1/6 size 4" deep pans. Each model includes a full set of 1/6 size food pans.

### Solid Construction - Inside & Out

The exterior of each Mega-Top Refrigerated Prep Table features stainless steel on the front and sides. The interior of the refrigerated cabinet are made from stainless steel, making it easy to wipe down and clean. The durable construction can withstand all of the hustle and bustle of busy foodservice environments.

### Full-Length Cutting Board

Each Supera® Mega-Top Refrigerated Prep Table is equipped with a full-length polyethylene cutting board. This durable, sanitary surface is perfect for preparing salads, sandwiches and other side dishes. The cutting board is easy to work on and easy to clean.



**MTPT1R-1**



**MTPT2R-1**



**MTPT2R6-1**



**MTPT3R-1**



### Features at a Glance:

- Includes stainless steel 1/6 size pans and adapter bars
- Inset door handles in the frame for easy ergonomic opening
- Door remains open past 90° for easy reloading
- Self-closing doors with premium gasket seals
- Removable ingredient rail for easy cleaning
- Cold air diffuser beneath ingredient rail
- Full-length polyethylene cutting board
- Attractive, durable stainless steel exterior
- Environmentally friendly refrigerant
- Front casters (4"D) are equipped with brakes
- Removable door gaskets for easy maintenance
- Includes NSF factory-installed heavy-duty shelf
- Stainless steel interior cleans easily
- Extra storage capacity for additional ingredients



# Mega-Top Refrigerated Prep Tables - Product Specifications

Model Numbers: MTPT1R-1, MTPT2R-1, MTPT2R6-1, MTPT3R-1

## Plan View

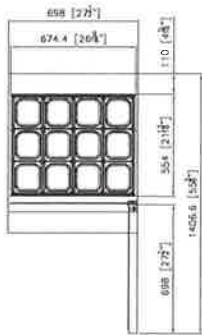

**TOP VIEW  
MTPT1R-1**

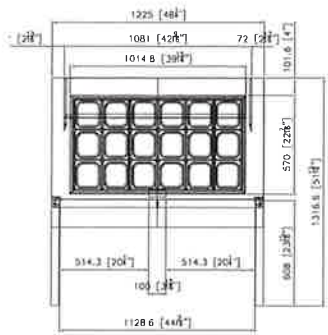

**TOP VIEW  
MTPT2R-1**

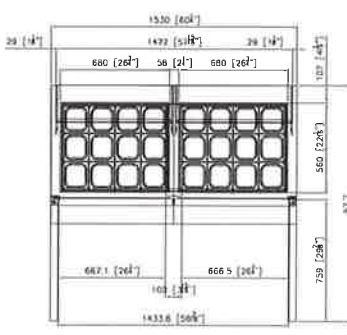

**TOP VIEW  
MTPT2R6-1**

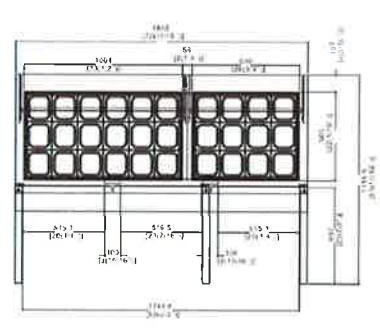

**TOP VIEW  
MTPT3R-1**

Mega-Top Refrigerated Prep Tables - PRODUCT SPECIFICATIONS				
SKU	MTPT1R-1	MTPT2R-1	MTPT2R6-1	MTPT3R-1
Exterior Dimensions (H x W x D)	46.6"H x 27.5"W x 34"D	46.6"H x 48.2"W x 34"D	46.6"H x 60.2"W x 34"D	38.25"H x 72.5"W x 34"D
Interior Dimensions (H x W x D)	26.7"H x 23.9"W x 23.6"D	26.7"H x 44.7"W x 23.6"D	26.7"H x 56.7"W x 23.6"D	26.7"H x 69.10"W x 23.6"D
Shipping Dimensions (H x W x D)	46.6"H x 31"W x 37"D	46.6"H x 51"W x 37"D	46.6"H x 63"W x 37"D	39"H x 75.5"W x 36"D
Cutting Board Dimensions	0.51"H x 27.24"W x 9.25"D	0.51"H x 48.03"W x 9.25"D	0.51"H x 60"W x 9.25"D	0.51"H x 72.44"W x 9.25"D
Capacity	7.9 Cu. Ft.	14.7 Cu. Ft.	18.6 Cu. Ft.	23 Cu. Ft.
Door Type	Solid Door	Solid Door	Solid Door	Solid Door
# of Doors	1	2	2	3
# of Shelves	1	2	2	3
Temperature Range	33°F ~ 41°F	33°F ~ 41°F	33°F ~ 41°F	33°F ~ 41°F
Refrigerant	R-134A	R-134A	R-134A	R-134A
Compressor HP	1/4	1/3	1/2	1/2
Temperature Control Type	Thermostat	Thermostat	Thermostat	Thermostat
Amps	4.2	6.5	6.5	9.9
NEMA Plug Type	5-15P	5-15P	5-15P	5-15P
Net Weight	220 lbs	267 lbs	353 lbs	397 lbs
Shipping Weight	242 lbs	287 lbs	375 lbs	419 lbs





## Equipment Stands

**Model Numbers: ES-2424, ES-2430, ES-3030, ES-3036, ES-3048**

### Supera® Stainless Steel Equipment Stands

Create the perfect work station with a Stainless Steel Equipment Stand from Supera®. The multi-function design gives you ample work and storage space in one without a lot of commitment on space. You can keep all your essential ingredients right there at the station so you're not running all over your kitchen just to make a burger or chicken sandwich.

## FEATURES

### Solid and Sturdy

Built to last with heavy duty stainless steel construction for increased durability; they won't falter on performance day after day. These equipment stands are solid and hold a whopping 1,100-1,300 pounds, so even your heaviest countertop equipment has a safe place in your kitchen.

### Dual Purpose Design

Supera® Stainless Steel Equipment Stands are perfect for work and storage. They come with an adjustable height galvanized steel under shelf that holds a variety of items to fit your kitchens design. Adjustable feet ensure stability on any flooring surface and these equipment stands can also be fitted with 3-1/2" heavy duty casters for ease of mobility during cleaning.

### The Real Deal

It's the little things that make an equipment stand better than the rest. This superior construction is hand formed and welded to create the perfect design in craftsmanship. End of day clean-up is simple with the smooth polished stainless steel table top and the side splash installed on the rear, right and left side of the stands ensure your mess stays on the surface and not on the floor.



**ES-2424**



**ES-3030**



**ES-3048**



### Features at a Glance:

- 430 polish stainless steel table top is 1-1/2" thick
- Dual purpose design for work and storage
- 2-1/2" thick gauge side splash installed on rear, right and left side of stand
- Holds between 1,100-1,300 lbs. for maximum strength and stability
- 1-1/2" thick legs with 1" adjustable feet
- Hand formed and welded
- NSF Approved
- Standard depth of 24" or 30" fits most commercial countertop equipment effectively
- Thick gauge galvanized steel under shelf with welded gussets
- Adjustable height under shelf holds a variety of items
- Smooth surface is easy to clean and maintain
- Can be fitted with 3-1/2" heavy duty casters for ease of mobility



## Equipment Stands – Product Specifications

Model Numbers: ES-2424, ES-2430, ES-3030, ES-3036, ES-3048

### Plan View

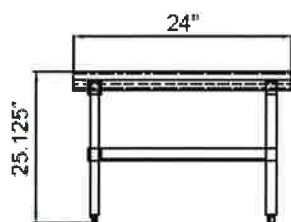

**ES-2424**

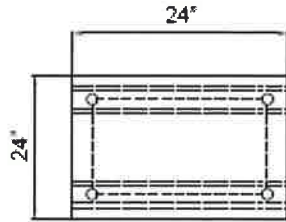

**ES-2430**

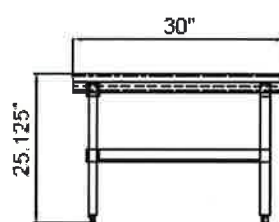

**ES-3030**

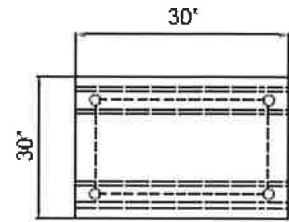

**ES-3036**

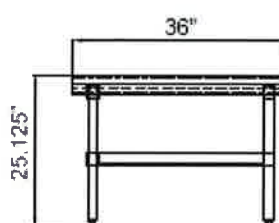
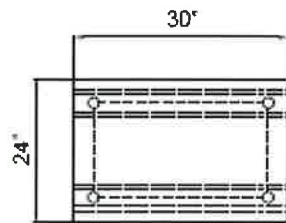
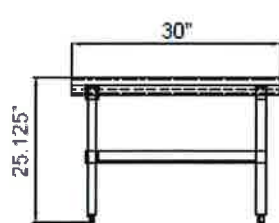

**ES-3048**

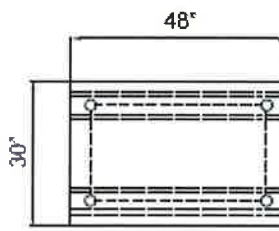
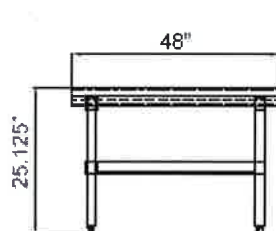
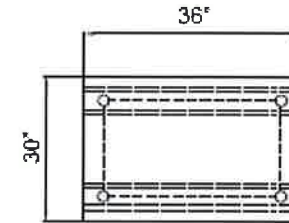

### Equipment Stands - PRODUCT SPECIFICATIONS

Model	ES-2424	ES-2430	ES-3030	ES-3036	ES-3048
Dimensions	24" x 24" x 24"	24" x 30" x 24"	24" x 30" x 30"	24" x 36" x 30"	24" x 48" x 30"
Shipping Weight	36.4 lbs	41.4 lbs	47.6 lbs	54 lbs	66.1 lbs
Capacity	1100 lbs	1100 lbs	1100 lbs	1300 lbs	1300 lbs
Backsplash Height	1.5"	1.5"	1.5"	1.5"	1.5"
Metal Type	Stainless Steel	Stainless Steel	Stainless Steel	Stainless Steel	Stainless Steel
# of Shelves	1	1	1	1	1

