

STATE OF LOUISIANA
Department of Public Safety and Corrections
Office of State Fire Marshal Code Enforcement and Building Safety
8181 Independence Boulevard
Baton Rouge, Louisiana 70806
225-925-4920

H "BUTCH" BROWNING
FIRE MARSHAL

WET CHEMICAL HOOD SYSTEM

ROBERT WILTSE
DAMMON ENGINEERING, INC
1095 FLORIDA AVE
SLIDELL, LA 70458

RE: P0392980
MARCO'S PIZZA FIRE SUPPRESSION SYSTEM
FOR KITCHEN
532 GAUSE BLVD
SLIDELL, LA 70469

NFPA 101, 2009

ASSEMBLY 300 OCCUPANTS OR LESS

Dear Applicant:

This review pertains to the piping lay-out and nozzle location(s), of the wet chemical system, for compliance with NFPA 17A, as shown on the drawings for the above referenced project.

This is to advise that we have reviewed the drawings and specifications for the subject proposed Fire Protection System and have determined that they appear to satisfactorily comply with the adopted laws, codes, rules and regulations of The State Fire Marshal subject to the following requirements:

- 1. THE REVIEWED SHOP DRAWINGS INDICATE THE FOLLOWING CONDITIONS. INSPECTOR PLEASE VERIFY AND CONTACT REVIEWER IF ANY DISCREPANCIES OCCUR.**

**WALL ADJACENT TO HOOD:
GYPSUM BOARD ON METAL STUD WALL**

**ROOF TERMINATION OF FAN:
METAL ROOF AND CEILING JOIST FRAMING**

USAGE OF FIREWRAP INSTALLED AT DUCT TO ACHIEVE A 0 INCH CLEARANCE TO FRAMING MATERIALS.

- 2. NOTE: THE COMMENTS LISTED BELOW IDENTIFY APPARENT DEFICIENCIES DETECTED IN OUR REVIEW OF THE DOCUMENTS SUBMITTED.**

96:4.2.1 Hoods, grease extractors and ducts shall have a clearance of at least 3 inches to limited combustible materials.

1. 96:4.2.4.3 Provide protection on the wall from the bottom of the hood to the floor, in the same manner as required for hood and duct protection for all wall mounted exhaust hoods, where occurring at wood stud walls.
3. 96:7.8.2.2 Hood exhaust fans shall be provided with safe access and a work surface for inspection and cleaning.
4. 70:430.102(b) Provide a disconnecting means for all rooftop (or sidewall) exhaust fans. This disconnect shall be located within sight of the exhaust fan. The disconnecting means shall be appropriately sized/rated for the exhaust fan motor.
5. 96:12.1.2.3.1 Provide an approved method that will ensure that all appliance(s) are returned to an approved design location, in the event they are moved for cleaning.
6. 96:10.10.1 Provide portable fire extinguishers in all kitchen cooking areas in accordance with NFPA 10. Class B "gas type" portables, such as carbon dioxide and halon, shall NOT be permitted in kitchen cooking areas.

NFPA 10 requires fire extinguishers provided for the protection of cooking appliances that use combustible cooking media (vegetable or animal oils and fats) to be listed and labeled for "Class K" fires.

7. 96:10.2.1.1 Provide a conspicuously placed placard near each portable fire extinguisher in the cooking area identifying its use as a secondary back-up means to the fixed automatic extinguishing system.

8. REQUIRED OPERATIONAL FEATURES

NFPA 96.8.3.1 Replacement air quantity shall be adequate to prevent negative pressures in the commercial cooking area from exceeding 0.02 inches of water column.

NFPA 96.10.5 The hood and duct extinguishing system manual pull station must be readily accessible, located in the path of egress, mechanically operated, and cannot rely on electrical power for actuation.

NFPA 96.10.4 The operation of the extinguishing system shall automatically shut off the supply fan (if ducted into the hood) and all sources of fuel and electric power that produce heat to protected equipment.

NFPA 96.8.2.3 The hood exhaust fan must continue to operate after extinguishing system activation.

NFPA 96.8.1.1 Approved upblast fans shall be hinged, supplied with flexible weatherproof electrical cable and service hold-open retainers, and listed for this use. INSPECTOR TO VERIFY.

NOTE: THE FOLLOWING COMMENTS IDENTIFY ISSUES FOR INFORMATIONAL AND CAUTIONARY PURPOSES OR ISSUES THAT COULD NOT BE VERIFIED IN THE SUBMITTED DOCUMENTS.

9. 96:12.1.2.2 Cooking appliances requiring protection shall not be moved, modified, or rearranged without prior reevaluation of the fire-extinguishing system by the system installer or servicing agent, unless otherwise allowed by the design of the extinguishing system.
10. 101:9.2.3 Construct and install kitchen exhaust hood, vent and automatic extinguishing system in accordance with NFPA 96 (2008).
 - a) 96:4.2.1 Hoods, grease extractors and ducts shall have a clearance of at least 18 in. to combustible materials, 3 in. to limited combustible materials and 0 in. to noncombustible materials, unless otherwise "listed".

- b) 96:5.1.1 The hood shall be constructed of not less than 18 gauge steel or 20 gauge stainless steel.
- c) 96:5.1.2 All seams, joints and penetrations shall have a liquidtight continuous external weld.
- d) 96:5.1.2 Hood penetrations shall be permitted to be sealed by devices listed for such use. Furnish the name of the manufacturer and model designation of each device as listed with an approved independent testing laboratory.
- e) 96:6.1 Provide listed grease removal system or listed grease removal filters. Listed grease filters shall be tested in accordance with U.L. 1046, "Grease Filters for Exhaust Ducts". Mesh filters shall not be used.
- f) 96:7.5.1 Ducts shall be 16 gauge steel or 18 gauge stainless steel.
- g) 96:7.8 Exhaust system shall terminate at exterior of building in accordance with this section.
- h) 96:7.1 Dampers shall not be installed in ducts unless specifically listed for such use.
- i) 96:10.1.2 Provide an approved automatic extinguishing system.
- j) 96:10.3.1 Activation of any extinguishing system that protects cooking operations shall automatically shut off all sources of fuel and electric power to all appliances protected by that system.
- k) 96:10.10.1 Provide portable fire extinguishers in all kitchen cooking areas in accordance with NFPA 10. Class B "gas type" portables, such as carbon dioxide and halon, shall NOT be permitted in kitchen cooking areas.

NFPA 10 requires fire extinguishers provided for the protection of cooking appliances that use combustible cooking media (vegetable or animal oils and fats) to be listed and labeled for "Class K" fires.

l) 96:12.1.2.4 All deep fat fryers shall be installed with at least a 16 in. space between the fryer and surface flames from adjacent cooking equipment.

m) 96:14.3.2 All solid fuel cooking equipment shall be served by hoods and duct systems that are separate from all other cooking exhaust systems.

11. 17A:5.4.6 The chemical container and expellant gas assemblies shall not be located where they will be exposed to the fire, (A minimum of 3 ft. from appliances is required), and shall be located near the protected hazard.

12. 17A:5.1.3 Installation of the suppression system shall be in accordance with the manufacturer's manual.

13. 96:10.5.1 and 17A:5.2.1.10 At least one manual control for actuation shall be located at least 42 inches and not more than 48 inches above the floor and be convenient and easily accessible at all times including the time of the fire.

14. 96:10.6 and 17A:5.2.1.9 The extinguishing system shall be connected to the fire alarm system, if provided, so that actuation of the extinguishing system will sound the fire alarm. If a fire alarm system is not in the building, an audible alarm or visual indicator shall be provided to show the system has operated.

15. 17A:4.3.1.5 Discharge nozzles shall be provided with blow-off caps.

16. 17A:6.4.4 The owner's manual or installation instructions and as-built drawings shall be given to the owner upon final acceptance of the system.

17. 96:10.2.3 and 17A:5.1.1 Installation of chemical systems for appliance protection shall be required to meet the UL-300 standard.

Changes to construction in the field which are not consistent with the reviewed documents are not authorized unless reviewed by this office for compliance with Code. Modifications to reviewed plans must be submitted to this office by the Architect/Civil Engineer for review prior to final inspection. If an Architect or Civil Engineer is not required by RS 37:155, revisions shall be submitted by the Owner. Submittals shall include plans, completed application, a minimum \$55.00 review fee, and a copy of the most current plan review letter.

This review is based on the information submitted concerning the fire protection system in the referenced facility. This review shall in no way permit and/or authorize any omissions or deviations from the specific requirements of the adopted codes, rules and regulations.

Occupancy of the project is permitted only upon the receipt of Contractor's Material & Test Certificate as per NFPA 13, Fire Alarm System Certificate and Description as per NFPA 72, or other certification as required by the applicable codes and a satisfactory inspection of the completed construction had been made by this office.

To arrange for inspection of the project, please contact the District Office at the phone number below two (2) to three (3) weeks in advance. The plans stamped reviewed by this office must be available on job site at time of inspection. Certificate of completion must be provided to the inspecting Deputy for final inspection.

This review is valid for 180 days from the date of this letter. Construction permits must be issued and/or construction must commence within this time period.

REVIEWED BY:
RON MATHIS
PLAN REVIEW DEPUTY

CC:
Sela Pizza
Herbert S Hiller Corporation
Property Insurance Association*
St Tammany Fire Protection District No 1*
Baton Rouge District* 2259253650

CHEMICAL FIRE SUPPRESSION SYSTEM REVIEW CHECKLIST & FEE SCHEDULE

As an aid to streamline our fire suppression system review process, we ask that you complete this checklist, and attach it to your Plan Review Application. Please address each checklist item in your package, whether the item is conveyed on the shop drawings, manufacturer cut sheets, general notes, pre-engineered data/calculations, or cover letter, etc. Any items not addressed may cause unnecessary delays or project "hold" on your review. Your help, up front, will facilitate a complete submittal package, shorten our review time, and help us to get your project reviewed and returned sooner. Please verify that each numbered item below is: A. in your submittal, B. correct, and C. is coordinated within the submittal (shop drawings match pre-engineered data/calculations and cut sheets). Then provide a check mark adjacent to each numbered item, or print "N/A" for items not applicable to this submittal. Thank you for your help, in completing and coordinating the items in this checklist.

Project Name (please print): MARCO'S PIZZA - FIRE SUPPRESSION SYSTEM FOR KITCHEN HOOD & APPLIANCE
Project Address: 532 GAUSE BLVD, SLIDELL, LA 70458 Architectural Review No. _____
Checklist Completed By: STEPHEN L. KRAMER Date: 1-19-11

PLAN REVIEW APPLICATION

1. This office cannot complete the review of the suppression system until we have issued an "appears to comply" architectural review letter for the protected space: either a room (computer room, telecommunications equipment room, paint spray room, etc.) or special area (kitchen hood, paint spray booth, computer floor, etc.). Please provide one of the following:
____ A. Furnish the State Fire Marshal project number, denoting review of the protected space (room or area). If this protected space is part of a previously reviewed architectural package, then provide the State Fire Marshal architectural review project number. (If there is no existing "appears to comply" architectural review letter from this office, or if the architectural review exists as a "Preliminary, Information Request, or Not-In-Compliance" type, the suppression package may be found not-in-compliance, and returned without benefit of a review.
____ B. If a previous appeal determination is involved with this fire suppression package, furnish copy of determination letter.
____ C. If the protected space is existing, then the Professional of Record (otherwise the Owner) shall denote such and include reason for this suppression submittal (replacing existing suppression system, modification of existing suppression system, order of correction by inspector, etc.) in writing, with the submittal. Otherwise, an architectural review letter of the protected space must accompany the suppression system submittal.
- N/A 2. Applicants requesting reviews under alternate code editions (other than 1993 NFPA 12: Standard On Carbon Dioxide Extinguishing Systems, 1992 NFPA 12A: Standard On Halon 1301 Fire Extinguishing Systems, 1994 NFPA 17 Standard For Dry Chemical Extinguishing Systems, 1994 NFPA 17A: Standard For Wet Chemical Extinguishing Systems, or 1996 NFPA 2001: Standard On Clean Agent Fire Extinguishing Systems) shall provide written request, stating reasons and life safety equivalencies.
- X 3. Project name, address, occupancy, and owner denoted on application, (and matches that of architectural review, if applicable).
- X 4. System type (Chemical, Wet Hood System, Dry Hood System).
- ____ 5. Professional of record name, address, licensee number, and signature.
- N/A 6. Copy of inspection report (State Fire Marshal, suppression contractor, etc.).
- X 7. Preparer of shop drawings information complete on application. All information shall match the State Fire Marshal Fire Protection Licensing & Registration Listing Of Certified Firms.

SHOP DRAWINGS

- X 8. Drawings are to be legible blueines, photocopies, or computer plots (any live ink applied by hand is not acceptable), and all drawn to scale.
- ____ 9. Professional of record shop drawing review and review stamp on each shop drawing sheet, and on cover of cut sheets (and on cover of calculations if applicable).

- X 10. Denote specific type of suppression system (total flooding, local application pre-engineered, etc.), and associated NFPA standard(s) utilized in design.
- X 11. Manual activation type and location.
- 12. Sequence of operations, (include actuation of building fire alarm system or hood suppression fire alarm, and/or simultaneous operations of multiple hazards, if applicable).
- N/A 13. Supervision type (electric or pneumatic).
- N/A 14. Clearances to electrical hazards.
- X 15. Method of actuation (automatic, normal, emergency).
- X 16. Method of automatic detection (heat, flame, smoke, combustible vapors, abnormal condition in hazard/process trouble).
- X 17. Method of operation (expellant gas releasing mechanisms, dry chemical discharge controls, shutdown of appliances or equipment, common or multiple hood configurations).
- X 18. Complete detection and suppression system with all devices labeled for type, size, quantity, location, and arrangement (pipe and fittings, nozzles, appliances, detectors, extinguishant type and containers, alarms and indicators).
- N/A 19. Two sources of electric power for alarms and indicators.
- X 20. Hood and ductwork configuration, for verification of compliant detection and suppression.
- N/A 21. For total flooding systems, denote dimensions of protected enclosure, method of closure for closable openings, area of unclosable openings.
- X 22. For local application systems, denote the location of the hazard, physical extent of the hazard,
- N/A 23. Method for inspection, maintenance, and recharging.

PRE-ENGINEERED DATA OR HYDRAULIC CALCULATIONS

- X 24. For pre-engineered systems, provide listed data (such as Underwriters Laboratories) denoting compliance and compatibility of the specific components and arrangement in the system.
- N/A 25. For calculated systems, provide calculations denoting suppression chemical amount, piping type, size, length, and arrangement, nozzle descriptions and locations of flow points, and nozzle flow rates.
- X 26. Location and function of detection devices, operating devices, auxiliary equipment, and electrical circuitry.
- N/A 27. Battery calculations.
- N/A 28. Reserve supply of extinguishant.

CUT SHEETS OF SUPPRESSION SYSTEM AND APPLIANCE PROTECTION

- N/A 29. Hood and ductwork configuration with listed protection criteria.
- X 30. Appliances with listed protection criteria.
- N/A 31. Pipe and fittings.
- X 32. Nozzles.
- X 33. Extinguishing agent containers.
- X 34. Detectors, indicators, and alarms.
- X 35. Operating devices.
- X 36. Fuel shutoff devices.
- N/A 37. Portable fire extinguishers.

FEE CALCULATIONS

1. Devices limited to suppression nozzles only.
2. Money orders, cashier's checks, certified checks, and company checks are accepted (NO PERSONAL CHECKS ACCEPTED, EFFECTIVE 9-1-00).

ITEM	NUMBER OF SYSTEMS	REVIEW FEE \$	SUB TOTAL FEES \$
Number of devices	1 - 10	x \$30	= \$
Number of devices	11 - 25	x \$60	= \$ 60
Number of devices	26 - 50	x \$120	= \$
Number of devices	51 - 75	x \$180	= \$
Number of devices	76 - 100	x \$200	= \$
Number of devices	101 - above	x \$300	= \$
Sets of calculations		x \$40	= \$
Add for fee increase plus postage and handling			+ \$ 25
Calculated fee attached		=	TOTAL \$ 85

Direct Gas Fired Conveyor Oven

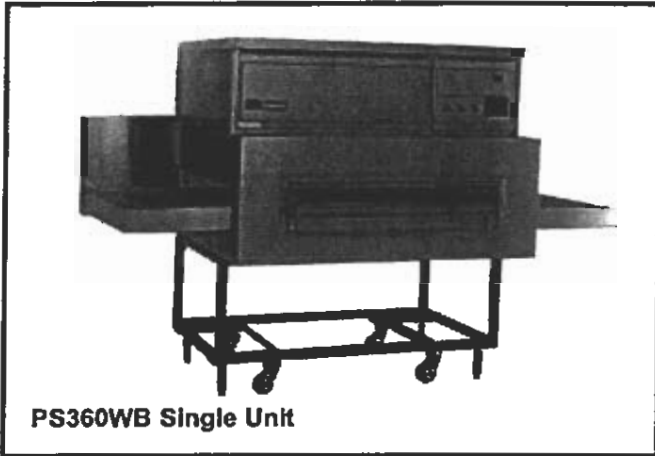

PS360WB Single Unit



PS360WB-D Double Unit

Principle

Middleby Marshall PS Series Conveyor ovens bake both faster and at a lower temperature than other ovens. Patented vertical columns of hot air move heat aerodynamically instead of using high temperatures. The streams of hot air remove the boundary layers of cool heavy air which tend to insulate the product. This gives very rapid baking without burning. All Middleby ovens are designed to cook a multitude of products including pizza, seafood, bagels, ethnic foods and more.

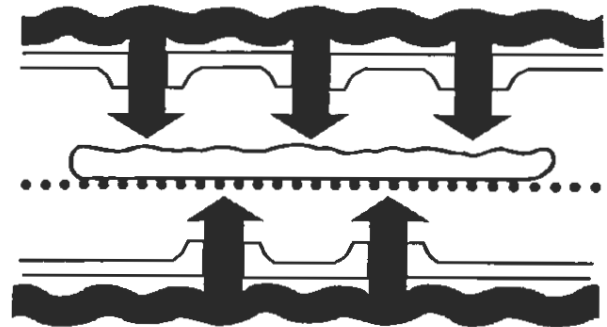

General Information

PS360WB conveyor ovens feature a 54.5" cooking chamber, a 40" wide conveyor belt, and a patented "Jet Sweep" impingement process that delivers constant heat to the chamber. All ovens feature microprocessor controlled bake time/conveyor speed. Eight adjustable jet fingers per chamber and front-loading window are standard. Ovens have stainless steel front, sides and top. All ovens include extra fan belt, installation kit, and 4' AGA flex hose. Heating is controlled in 8" adjustable zones. Top and bottom are independently adjustable. The conveyor drive is reversible. Conveyor belt provides automatic delivery when product is finished. Front loading window with cool handle design allows product with different bake times to be cooked consistently regardless of loading.

Special Features

PS360WB units are stackable two high. Split belt option also available upon request.

Conserves Energy

Middleby ovens provide very efficient heat transfer to product. Energy is conserved as air is recycled from heater to product, with minimum flue or vent loss.

Cleanability

PS360WB ovens are designed for easy cleaning. Removable parts include: crumb pans, end panels, air fingers and a folding conveyor belt assembly for easy removal.

Easily Serviced

Control compartment is designed for quick and easy access. All electrical controls are door mounted.

Warranty

All PS360WB models have a one year parts and labor warranty. Oven start-up and demonstration are included at no additional charge (USA only).

Ventilation

For installation under a ventilation hood only.

Middleby Marshall Model PS360WB Direct Gas Fired Conveyor Oven

Baking chamber opening: 3.875" (98.42 mm).
Scale .25" (6.35 mm) = 1" (304.8 mm) approx.

NOTE: All Figures In Parentheses Are In Millimeters
Unless Otherwise Specified

TOP VIEW OF BOTH THE
PS360WB SINGLE AND
PS360WB-D DOUBLE

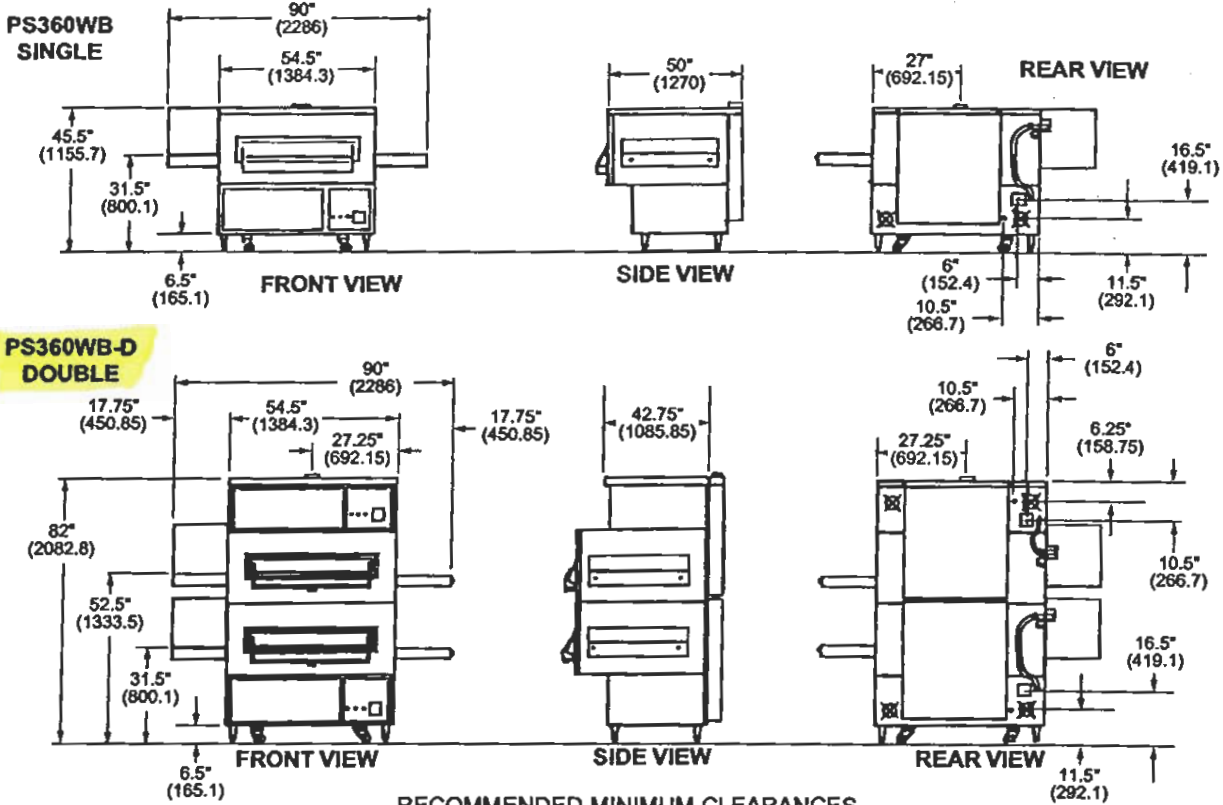
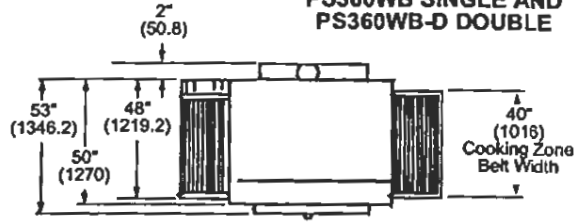

RECOMMENDED MINIMUM CLEARANCES

Rear of Oven to Wall	Left Conveyor Extension to Wall	Right Conveyor Extension to Wall (control panel side)
1" (25.4)	0"	0"

GENERAL INFORMATION

	Heating Zone	Bake Chamber	Belt Width	Height	Width	Depth	Max. Operating Temp.	Bake Time Range	Ship Wt. (lbs.)	Ship Cube per cavity
PS360WB Single	54.5" (1384.3)	15.14 sq. ft. (1.406 sq. m)	40" (101.6)	45.5" (1155.7)	90" (2286)	55" (1397)	550° (287°C)	2 min., 40 sec. to 29 min., 50 sec.	1500	126.3 ft ³
PS360WB Double	109" (2768.6)	30.28 sq. ft. (2.813 sq. m)	40" (101.6)	82" (2082.8)	90" (2286)	55" (1397)	550° (287°C)	2 min., 40 sec. to 29 min., 50 sec.	3000	126.3 ft ³

GAS SUPPLY PROVIDED BY CUSTOMER

	Min. Gas Pipe Size	Gas Valves (full flow gas shut-off valve)	Req'd Supply Gas Pressure*	Power
Natural Gas 1 or 2 ovens	2" (508) NPT	.75" (19.05) ID each oven	6" (15mbar) to 14" (35mbar) water column	170,000 BTU/HR (50kW) per cavity
Propane Gas 1 or 2 ovens	1.5" (38.1) NPT	.75" (19.05) ID each oven	6" (15mbar) to 14" (35mbar) water column (CE Max 50mbar)	170,000 BTU/HR (50kW) per cavity

ELECTRICAL RATINGS per cavity

Gas Fired Ovens	Voltage	Phase	HZ	Amps	Supply	Breakers
PS360WB	208 - 240	1	60	12	3 pole, 4 wire (2 hot, 1 neutral, 1 ground)	per local codes
PS360WB (CE Listed)	220 - 230	1	50	2400 Watts	2 pole, 3 wire (1 hot, 1 neutral, 1 ground)	per local codes



Above specifications subject to change without notice.
* For CE gas supply applications, please consult factory for specifics.



Steve Kramer

From: Harding, Curt [charding@tycointl.com]
Sent: Monday, November 22, 2010 8:15 AM
To: Steve Kramer
Subject: RE: R-102 System Protection of Pizza Oven
Attachments: GB 5653 - R-102 Pizza Oven Fire Protection.pdf

Steve,

You will have to follow our prior recommendations for conveyor pizza ovens per the attached bulletin. You are looking at 4) 1N nozzles per conveyer.

Curt Harding | Technical Services – Applications Specialist | Tyco Fire Suppression & Building Products | One Stanton Street, Marquette, WI 54143 – USA | Phone: +1-715-735-7411 Ext. 73501 | E-mail: charding@tycointl.com

This message contains information which may be confidential and privileged. Unless you are the addressee (or authorized to receive this message for the addressee), you may not use, copy or disclose to anyone the message or any information contained in the message. If you have received this message in error, please advise the sender by reply e-mail and delete the message. Thank you.

From: Steve Kramer [mailto:skramer@hillercompanies.com]
Sent: Friday, November 19, 2010 4:29 PM
To: Harding, Curt
Cc: Philip Becker
Subject: R-102 System Protection of Pizza Oven

Curt,

As you requested by telephone this afternoon, the data sheet for the pizza oven we are trying to protect is attached to this e-mail. Please review the double conveyor size (40" x 55" per upper & lower conveyor) and recommend the correct nozzle type & quantity for proper protection so that we can complete our quotation estimate for our customer. Thanks.

Steve Kramer
Herbert S. Hiller Corp.
Engineering
504-736-0008



by Tyco Fire Suppression & Building Products

One Stanton Street
Marinette, WI 54143-2542
www.ansul.com

Bulletin

Bulletin No. 5653

DATE: April 29, 2010
TO: All Authorized ANSUL R-102 System Distributors and OEMS's
FROM: Product Management – Restaurant Systems
SUBJECT: Non-UL-Listed Fire Protection for Conveyor Pizza Ovens

The UL300 Standard: *Fire Testing of Fire Extinguishing System for Protection of Commercial Cooking Equipment* does not currently address a test protocol for conveyor pizza oven protection. However, in many jurisdictions, the Authority Having Jurisdiction has required fire protection for conveyor pizza ovens. In the past, appliances not addressed in the UL300 test standard have been protected by following listed protection options for other appliances with similar operating characteristics. Generally, these appliances presented a more severe hazard than the appliance in question. In the case of conveyor pizza ovens, chain broiler protection was utilized.

To confirm recommended protection, we recently conducted a conveyor pizza oven fire test following the chain broiler test protocol outlined in UL 300, substituting fatty hamburgers with a grease coated pizza crust, to emulate the cooking process used by conveyor pizza ovens.

Prior recommendations for conveyor pizza ovens larger than the two 1N horizontal nozzle limitations for a chain broiler, suggested using four 1N nozzles, each positioned at the end corners and aimed diagonally across the chain within the oven. Based on the actual fire testing, we now recommend two 245 nozzles per conveyor: one nozzle is positioned at the inlet and one nozzle is positioned at the outlet of the conveyor pizza oven on the same side of the oven and aimed at the opposite corners. Utilizing two 245 nozzles as recommended is suitable protection for conveyors larger than the limitations for a chain broiler but not exceeding 38 in.(96.5 cm) wide x 70 in (177.8 cm) long.

If you should have questions pertaining to this bulletin, please contact your U.S. District Manager or International Area Manager, or call Technical Services as noted below.

MARCO'S PIZZA SELA #2
 534 GAUSE BLVD
 SLIDELL, LA

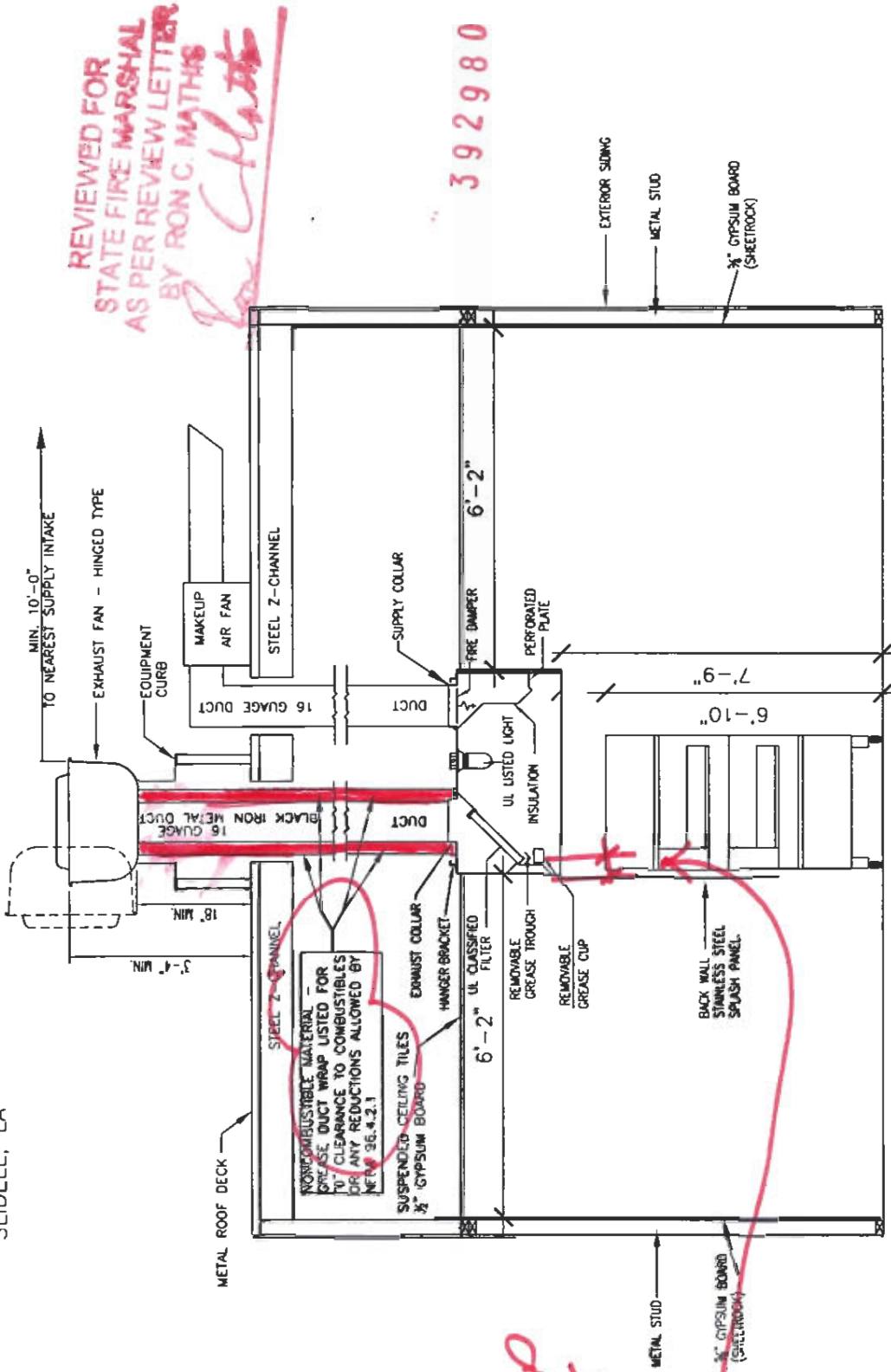

REVIEWED FOR
 STATE FIRE MARSHAL
 AS PER REVIEW LETTER
 BY RON C. MATHIS
Ron Mathis

392980

TYPICAL MARCO'S PIZZA HOOD & DUCT INSTALLATION
 N.T.S

Hood splash
 panel offset
 by 3"

HOOD INFORMATION TABLE

HOOD NO.	MODEL	LGTH	WIDTH	MAX. COOKING TEMP.	AIR REQUIREMENTS						TOTAL SUP CFM	HOOD CONFIGURATION	PLENUM		CEILING ENCLOSURE			
					EXHAUST COLLAR		SUPPLY COLLAR		HOOD CONSTRUCTION	END/BACK/BACK			FRONT	MATERIAL		HEIGHT		
					SIZE	EXHAUST	SIZE	SUPPLY										
1	SC	11'-0"	72"	450 DEG	QTY	W	L	CFM	S.P.	QTY	W	L	CFM	430 S/S	-	-	-	-
					1	16"	16"	3300	625"	3300	10"	36"	2310	2310				

* 48" TALL BACK WALL SPLASH PANEL PROVIDED WITH HOOD *

ANSUL®

**DESIGN
INSTALLATION
RECHARGE AND
MAINTENANCE
MANUAL**

**R-102 RESTAURANT
FIRE SUPPRESSION
SYSTEM
(Standard UL 300 Listed)**

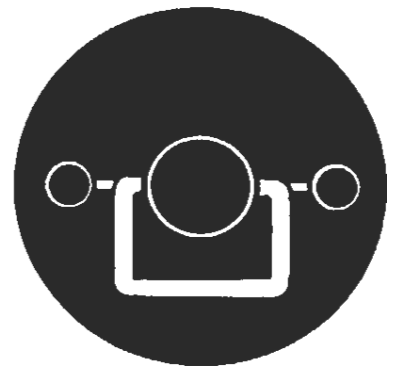
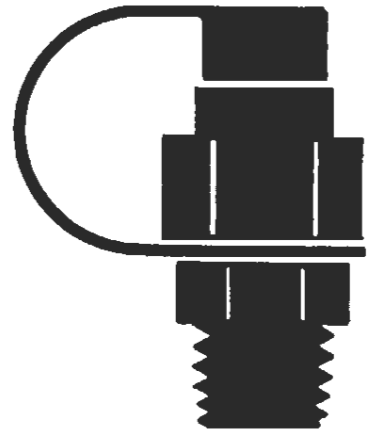
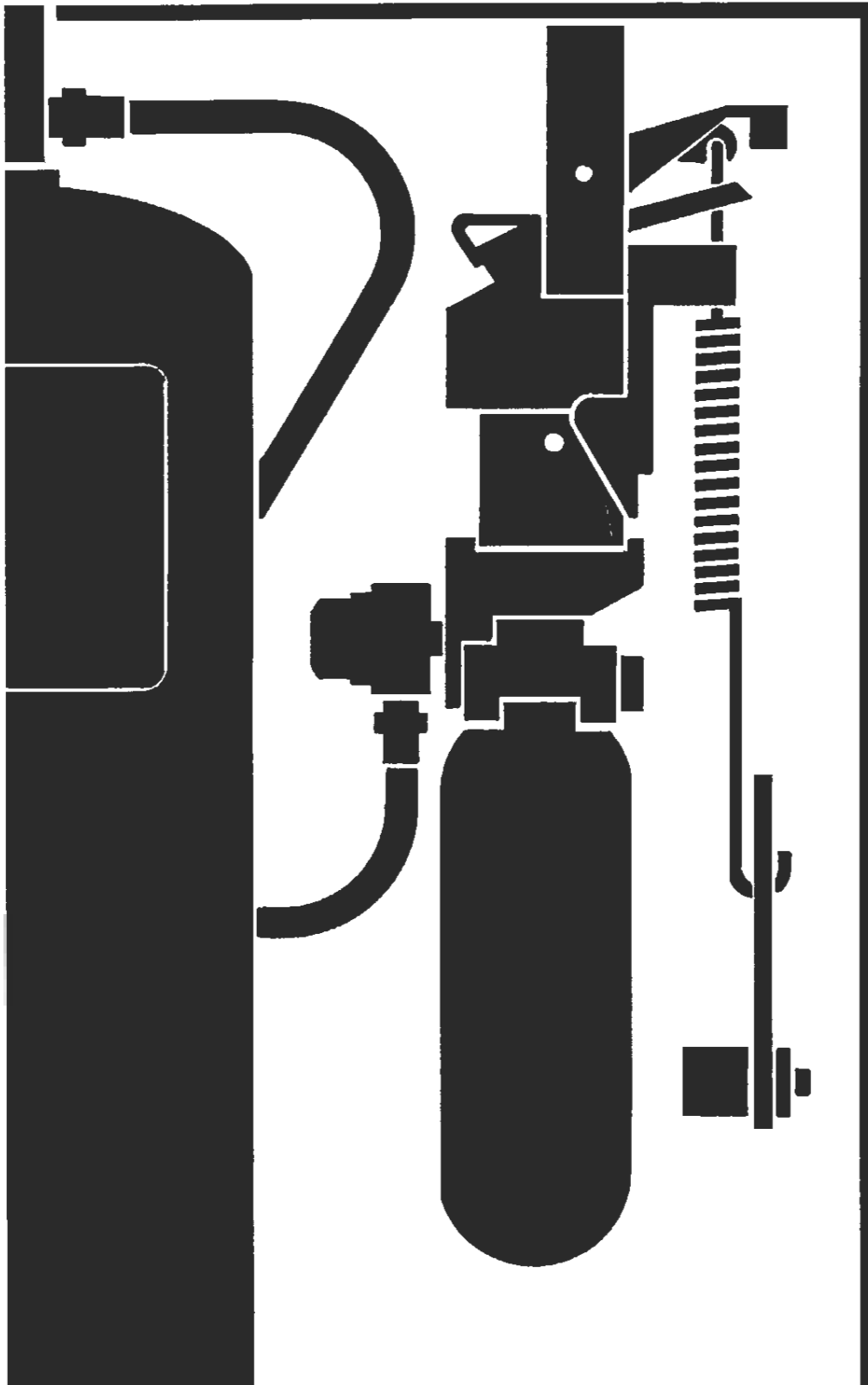

This manual is intended for use with ANSUL® R-102™ Restaurant Fire Suppression Systems.

Those who install, operate, recharge, or maintain these fire suppression systems should read this entire manual. Specific sections will be of particular interest depending upon one's responsibilities.

Design, installation, recharge, and maintenance of the system must conform to the limitations detailed in this manual and performed by an individual who attended an ANSUL training program and became trained to install, recharge, design, and maintain the ANSUL system.

Fire suppression systems are mechanical devices. They need periodic care. Maintenance is a vital step in the performance of your fire suppression system. As such it must be performed in accordance with NFPA 96 (Standard for the Installation of Equipment for the Removal of Smoke and Grease-Laden Vapors from Commercial Cooking Equipment) and NFPA 17A (Standard on Wet Chemical Extinguishing Systems) by an authorized ANSUL distributor. To provide maximum assurance that the fire suppression system will operate effectively and safely, maintenance must be conducted at six-month intervals, or earlier if the situation dictates. Twelve-year maintenance must include agent tank hydrostatic testing.

ANSUL PART NO. 418087-11

ANSUL, ANSUL AUTOMAN and ANSULEX are trademarks of Tyco International Ltd. or its affiliates.

DATE	PAGE	REV. NO.	DATE	PAGE	REV. NO.
8-1-01	5-27	Deleted	7-1-09	1-3	New
10-1-02	4-7	3	7-1-09	1-4	New
10-1-02	6-4	2	7-1-09	2-1	4
10-1-02	9-2	5	7-1-09	2-2	5
10-1-02	9-3	5	7-1-09	3-1	6
10-1-02	9-4	7	7-1-09	3-2	6
10-1-02	9-8	3	7-1-09	3-5	8
10-1-02	9-10	3	7-1-09	3-6	7
10-1-02	9-11	5	7-1-09	3-7	6
10-1-02	9-15	Deleted	7-1-09	3-8	8
10-1-02	9-16	Deleted	7-1-09	3-9	5
4-1-06	3-3	8	7-1-09	3-10	4
4-1-06	3-4	7	7-1-09	3-11	1
4-1-06	4-2	4	7-1-09	3-12	1
4-1-06	4-8	6	7-1-09	4-1	8
4-1-06	4-9	8	7-1-09	4-3	5
4-1-06	4-11	8	7-1-09	4-4	7
4-1-06	5-2.1	5	7-1-09	4-5	5
4-1-06	9-9	4	7-1-09	4-6	7
4-1-06	9-10.2	2	7-1-09	4-10	7
7-1-09	In addition to the revised technical information, the ULC Listing file number at the top of each manual page has been updated.		7-1-09	4-12	6
7-1-09	T.O.C. – Page 1	10	7-1-09	4-13	8
7-1-09	T.O.C. – Page 2	8	7-1-09	4-14	6
7-1-09	1-1	6	7-1-09	4-15	5
7-1-09	1-2	6	7-1-09	4-16	7
			7-1-09	4-17	6
			7-1-09	4-18	7

- ▶ Indicates revised information.
- Indicates change in page sequence.

REVISION INDEX

UL EX3470 ULC EX3470 Page 2

REV. 6 7-1-09

DATE	PAGE	REV. NO.	DATE	PAGE	REV. NO.
7-1-09	4-19	4	7-1-09	4-42	7
7-1-09	4-20	5	7-1-09	4-43	6
7-1-09	4-21	4	7-1-09	4-43.1	New
7-1-09	4-22	5	7-1-09	4-43.2	New
7-1-09	4-23	8	7-1-09	4-43.3	New
7-1-09	4-24	7	7-1-09	4-43.4	New
7-1-09	4-25	7	7-1-09	4-44	6
7-1-09	4-26	6	7-1-09	4-45	4
7-1-09	4-27	5	7-1-09	4-46	6
7-1-09	4-28	6	7-1-09	4-47	5
7-1-09	4-29	6	7-1-09	4-48	6
7-1-09	4-30	4	7-1-09	4-49	5
7-1-09	4-31	7	7-1-09	4-50	5
7-1-09	4-32	7	7-1-09	4-51	5
7-1-09	4-33	6	7-1-09	4-52	4
7-1-09	4-34	8	7-1-09	4-53	4
7-1-09	4-34.1	1	7-1-09	4-54	5
7-1-09	4-34.2	1	7-1-09	4-55	4
7-1-09	4-34.3	New	7-1-09	4-56	4
7-1-09	4-34.4	New	7-1-09	4-57	2
7-1-09	4-35	6	7-1-09	4-58	2
7-1-09	4-36	5	7-1-09	4-59	2
7-1-09	4-37	5	7-1-09	4-60	2
7-1-09	4-38	8	7-1-09	4-61	New
7-1-09	4-39	7	7-1-09	4-62	New
7-1-09	4-40	6	7-1-09	5-1	7
7-1-09	4-41	6	7-1-09	5-2	5

► Indicates revised information.

■ Indicates change in page sequence.

DATE	PAGE	REV. NO.	DATE	PAGE	REV. NO.
7-1-09	5-3	3	7-1-09	5-17.9	New
7-1-09	5-4	5	7-1-09	5-17.10	New
7-1-09	5-5	5	7-1-09	5-17.11	New
7-1-09	5-6	4	7-1-09	5-17.12	New
7-1-09	5-7	6	7-1-09	5-18	6
7-1-09	5-7.1	New	7-1-09	5-19	5
7-1-09	5-7.2	New	7-1-09	5-20	3
7-1-09	5-7.3	New	7-1-09	5-20.1	New
7-1-09	5-7.4	New	7-1-09	5-20.2	New
7-1-09	5-8	3	7-1-09	5-20.3	New
7-1-09	5-9	2	7-1-09	5-20.4	New
7-1-09	5-10	3	7-1-09	5-21	4
7-1-09	5-11	3	7-1-09	5-22	4
7-1-09	5-12	4	7-1-09	5-23	Deleted
7-1-09	5-13	3	7-1-09	5-24	Deleted
7-1-09	5-14	3	7-1-09	5-25	Deleted
7-1-09	5-15	4	7-1-09	5-26	Deleted
7-1-09	5-16	3	7-1-09	6-1	3
7-1-09	5-17	4	7-1-09	6-2	3
7-1-09	5-17.1	New	7-1-09	6-3	4
7-1-09	5-17.2	New	7-1-09	7-2	6
7-1-09	5-17.3	New	7-1-09	7-3	5
7-1-09	5-17.4	New	7-1-09	7-4	3
7-1-09	5-17.5	New	7-1-09	8-1	8
7-1-09	5-17.6	New	7-1-09	8-2	4
7-1-09	5-17.7	New	7-1-09	8-3	5
7-1-09	5-17.8	New	7-1-09	8-4	6

- ▶ Indicates revised information.
- Indicates change in page sequence.

SECTION	PAGES	SECTION	PAGES
I. GENERAL INFORMATION	1-1 – 1-4	III. SYSTEM COMPONENTS	3-1 – 3-12
DESIGN AND APPLICATION	1-1	(Continued)	
UL LISTING	1-1	PULLEY TEE	3-8
SYSTEM APPROVALS	1-1	STAINLESS STEEL CABLE	3-8
DEFINITION OF TERMS	1-1 – 1-3	REMOTE MANUAL PULL STATION	3-9
		FLEXIBLE CONDUIT	3-9
II. SYSTEM DESCRIPTION	2-1 – 2-2	MECHANICAL GAS VALVES	3-9
TOTAL SYSTEM	2-1	ELECTRICAL GAS VALVES	3-10
Single-Tank	2-1	MANUAL RESET RELAY	3-10
Double-Tank	2-1	ELECTRICAL SWITCHES	3-10
Three-Tank	2-2	ALARM INITIATING SWITCH	3-11
Multiple-Tank	2-2	REGULATOR TEST KIT	3-11
		FUSIBLE LINK	3-11
III. SYSTEM COMPONENTS	3-1 – 3-12	MAXIMUM REGISTERING	3-11
EXTINGUISHING AGENT	3-1	THERMOMETER	
"ANSUL AUTOMAN" REGULATED	3-1	HOSE/GROMMET PACKAGE	3-11
RELEASE ASSEMBLY		IN-LINE BURST DISC ASSEMBLY	3-12
(MECHANICAL)		(MANIFOLDED SYSTEMS ONLY)	
"ANSUL AUTOMAN" REGULATED	3-1	1/4 IN. CHECK VALVE	3-12
RELEASE ASSEMBLY		NOZZLE AIMING DEVICE	3-12
(ELECTRICAL)		STAINLESS STEEL ACTUATOR HOSE	3-12
REMOTE MECHANICAL RELEASE	3-2	AGENT DISTRIBUTION HOSE AND	3-12
SINGLE TANK ENCLOSURE	3-2	RESTRAINING CABLE KIT	
ASSEMBLY			
RED PAINTED BRACKET ASSEMBLY	3-2	IV. SYSTEM DESIGN	4-1 – 4-62
REGULATED ACTUATOR	3-2	NOZZLE PLACEMENT	4-1 – 4-31
ASSEMBLY		REQUIREMENTS	
AGENT TANK ASSEMBLY	3-3	Duct Protection	4-1 – 4-3
OEM RELEASE/BRACKET	3-3	Transition Protection	4-4
ASSEMBLY (FOR OEM		Electrostatic Precipitator	4-4
IN-CABINET USE ONLY)		Protection	
OEM REGULATED ACTUATOR	3-3	Plenum Protection	4-5 – 4-6
ASSEMBLY		Appliance Protection	
TWO TANK ENCLOSURE ASSEMBLY	3-3	Fryer – Single Nozzle Protection	4-7 – 4-9
24 VDC REGULATED RELEASE	3-4	Multiple Nozzle Fryer Protection –	4-10 – 4-12
ASSEMBLY		Tilt Skillet/Braising Pan	4-12
ADDITIONAL SHIPPING ASSEMBLY	3-4	Range Protection	4-13 – 4-17
GAS CARTRIDGES	3-5	Griddle Protection	4-18 – 4-21
NOZZLES	3-5	Chain Broiler Protection	4-22
SILICONE LUBRICANT	3-5	Horizontal Chain Broiler Protection	4-22
SWIVEL ADAPTOR	3-6	Overhead Chain Broiler Protection	4-22 – 4-23
RUBBER BLOW-OFF CAP	3-6	Upright/Salamander Broiler	4-23
CB METAL BLOW-OFF CAP	3-6	Protection	
CONDUIT OFFSET ASSEMBLY	3-6	Gas-Radiant/Electric Char-Broiler	4-24
"QUIK-SEAL" ADAPTOR	3-6	Protection	
"COMPRESSION-SEAL" ADAPTOR	3-7	Lava-Rock (Ceramic) Char-Broiler	4-25
"HOOD SEAL" ADAPTOR	3-7	Protection	
ASSEMBLY		Natural Charcoal Broiler Protection	4-25
REDUCING COUPLING	3-7	Alternate Ceramic/Natural	4-26
COCKING LEVER/LOCK BAR	3-7	Charcoal Char-Broiler Protection	
DETECTORS	3-8	Wood Fueled Char-Broiler Protection	4-26
PULLEY ELBOWS	3-8	Wok Protection	4-27
		Nozzle Application Chart	4-28 – 4-31
		Specific Application by Model	4-32 – 4-42
		Overlapping Nozzle Coverage	4-43 – 4-46

SECTION	PAGES	SECTION	PAGES
IV. SYSTEM DESIGN (Continued)	4-1 – 4-62	V. INSTALLATION INSTRUCTIONS (Continued)	5-1 – 5-22
TANK AND CARTRIDGE REQUIREMENTS	4-47	INSTALLING ELECTRICAL GAS VALVE	5-18
ACTUATION AND EXPELLANT GAS LINE REQUIREMENTS	4-47 – 4-49	INSTALLING ELECTRICAL SWITCHES	5-19 – 5-20
DISTRIBUTION PIPING REQUIREMENTS	4-49 – 4-56	INSTALLING ALARM INITIATING SWITCH	5-20
General Piping Requirements	4-49	ELECTRICAL SWITCH REQUIREMENTS	5-20.1 – 5-20.3
Supply and Branch Line Identification	4-50 – 4-51	WIRING 24 VDC REGULATED RELEASE ASSEMBLY	5-21
1.5 Gallon System	4-52		
3.0 Gallon System	4-53	VI. TESTING AND PLACING IN SERVICE	6-1 – 6-4
6.0 Gallon Manifolded System	4-54 – 4-55	TESTING MANUAL PULL STATION	6-1
9.0 Gallon System	4-56	TESTING MECHANICAL GAS VALVES	6-1
DETECTION SYSTEM REQUIREMENTS	4-57 – 4-58	TESTING ELECTRICAL GAS VALVES	6-2
Detector Identification	4-57	TESTING ELECTRIC SWITCH	6-2
Detector/Pulley Elbow Quantity	4-57	TESTING DETECTION SYSTEM	6-3
Detector Placement Requirements	4-57 – 4-58		
Detection Line Requirements	4-58	VII. RECHARGE AND RESETTING PROCEDURES	7-1 – 7-4
Fusible Link Selection	4-58	CLEANUP PROCEDURES	7-1
MANUAL PULL STATION REQUIREMENTS	4-59	RECHARGE	7-1 – 7-3
MECHANICAL GAS VALVE REQUIREMENTS	4-59 – 4-60	RESETTING	7-3 – 7-4
ELECTRICAL GAS VALVE REQUIREMENTS	4-60	REPLACEMENT CARTRIDGE	7-4
Approvals	4-60		
ALARM INITIATING SWITCH REQUIREMENTS	4-60	VIII. MAINTENANCE EXAMINATION	8-1 – 8-10
ELECTRICAL SWITCH REQUIREMENTS	4-60 – 4-61	SEMI-ANNUAL MAINTENANCE EXAMINATION	8-1 – 8-4
V. INSTALLATION INSTRUCTIONS	5-1 – 5-22	ANNUAL MAINTENANCE EXAMINATION	8-5
MOUNTING THE COMPONENTS	5-1 – 5-2.1	12-YEAR MAINTENANCE EXAMINATION	8-5 – 8-9
INSTALLING THE ACTUATION AND EXPELLANT GAS LINES	5-3 – 5-6		
INSTALLING THE DISTRIBUTION PIPING	5-7	IX. APPENDIX	9-1 – 9-14
INSTALLING THE AGENT DISTRIBUTION HOSE (FOR CASTERED/MOVEABLE EQUIPMENT)	5-7.1 – 5-7.3	SYSTEM SELECTION GUIDE	9-1 – 9-4
INSTALLING THE DETECTION SYSTEM	5-8 – 5-11	SYSTEM COMPONENT INDEX	9-5 – 9-6.2
"Scissors" Style Linkage Installation	5-8 – 5-11	PARTS LISTS	9-7 – 9-10.2
INSTALLING REMOTE MANUAL PULL STATION	5-12 – 5-13	MULTIPLE NOZZLE FRYER PROTECTION CALCULATION EXAMPLES	9-11
General Installation Requirements	5-12	WIRING DIAGRAM	9-12 – 9-13
Installation for Remote Manual Pull Station Utilizing EMT Conduit Only	5-12 – 5-13		
INSTALLING MECHANICAL GAS VALVE	5-13 – 5-17		
INSTALLATION REMOTE MANUAL PULL STATION OR MECHANICAL GAS VALVE UTILIZING FLEXIBLE CONDUIT	5-17 – 5-17.11		

DESIGN AND APPLICATION

The ANSUL R-102 Restaurant Fire Suppression System is designed to provide fire protection for restaurant cooking appliances, hoods, and ducts. It is a pre-engineered group of mechanical and electrical components for installation by an authorized ANSUL distributor. The basic system consists of an ANSUL AUTOMAN regulated release assembly which includes a regulated release mechanism and a liquid agent storage tank housed within a single enclosure. Nozzles, detectors, cartridges, liquid agent, fusible links, pulley tees, and pulley elbows are supplied in separate packages in the quantities needed for each fire suppression system arrangement.

The system provides automatic actuation; or it can be actuated manually through a remote manual pull station. The system is also capable of shutting down appliances at system actuation. For appliance shutdown requirements, refer to the current version of NFPA 17A, "Standard For Wet Chemical Extinguishing Systems," and NFPA 96, "Standard For Ventilation Control and Fire Protection of Commercial Cooking Operations."

Additional equipment includes: remote manual pull station, mechanical and electrical gas valves, and electrical switches for automatic equipment and gas line shut-off. Accessories can be added, such as alarms, warning lights, etc., to installations where required.

The R-102 system suppresses fire by spraying the plenum area, the filters, cooking surfaces, and the exhaust duct system with a predetermined flow rate of ANSULEX Low pH Liquid Fire Suppressant. When the liquid agent is discharged onto a cooking appliance fire, it cools the grease surface, and reacts with the hot grease (saponification) forming a layer of soap-like foam on the surface of the fat. This layer acts as insulation between the hot grease and the atmosphere, thus helping to prevent the escape of combustible vapors.

Exhaust fans in the ventilating system should be left on. The forced draft of these fans assists the movement of the liquid agent through the ventilating system, thus aiding in the fire suppression process. These fans also provide a cooling effect in the plenum and duct after the fire suppression system has been discharged. The system is UL listed with or without fan operation.

Make up or supply air fans, integral to the exhaust hood(s) being protected, shall be shut down upon system actuation.

Along with the fire suppression system, the total system design must include hand portable fire extinguisher(s) located within the cooking/restaurant area that can be used to manually suppress a fire that may be burning in an unprotected area. Class K extinguisher(s) must be provided for hazards where there is a potential for fires involving combustible cooking media (vegetable or animal oils and fats). Refer to NFPA 10, "Standard For Portable Fire Extinguisher," for additional information.

UL LISTING

The R-102 Restaurant Fire Suppression System has been tested and is listed by Underwriters Laboratories, Inc. as a pre-engineered system. The system is in compliance with UL Test Standard 300. These tests require extinguishment of fires which are initiated in deep fat fryers, ranges, griddles, char-broilers, woks, upright broilers, chain-broilers, filters, plenum chambers, hoods, and ducts after pre-loading each appliance with a prescribed amount of cooking grease. Each fire is allowed to progress to maximum intensity before the fire suppression system is actuated.

SYSTEM APPROVALS

- UL EX3470
- ULC EX3470
- MEA 59-95E

DEFINITION OF TERMS

Actuation Gas Line: Piping and/or stainless steel braided hose assemblies from the ANSUL AUTOMAN Regulated Release Assembly which supplies high pressure nitrogen or carbon dioxide to the Regulated Actuator Assembly for multiple-tank system actuation.

Agent Tank: A pressure vessel containing the liquid agent.

ANSUL AUTOMAN Regulated Release Assembly (Electrical): An assembly which contains the regulated release mechanism, agent tank (ordered separately), expellant gas hose, solenoid, and electric switch within a metal enclosure. The enclosure contains knockouts to facilitate component hookups.

ANSUL AUTOMAN Regulated Release Assembly (Mechanical): An assembly which contains the regulated release mechanism, agent tank (ordered separately), and expellant gas hose within a metal enclosure. The enclosure contains knockouts to facilitate component hookups.

Authority Having Jurisdiction: The "authority having jurisdiction" is the organization, office, or individual responsible for "approving" equipment, an installation, or a procedure. The phrase "Authority Having Jurisdiction" is used in a broad manner since jurisdictions and "approval" agencies vary as do their responsibilities. Where public safety is primary, the "authority having jurisdiction" may be a federal, state, local, or other regional department or individual such as a fire chief, fire marshal, chief of a fire prevention bureau, labor department, health department, building official, electrical inspector, or others having statutory authority. For insurance purposes, an insurance company representative may be the "authority having jurisdiction." In many circumstances the property owner or his designated agent assumes the role of the "authority having jurisdiction;" at government installations, the commanding officer or departmental official may be the "authority having jurisdiction."

Blow-Off Cap: A siliconized rubber or metal cap which covers the end of the nozzle to protect the nozzle tip and minimize cooking grease migration into the nozzle orifice.

Branch Line: The agent distribution piping which extends from the supply line to the nozzle(s).

Bursting Disc: A disc installed in the tank adaptor which minimizes the remote chance of siphoning of the agent into the discharge piping during extreme temperature variations.

Cartridge: A hermetically sealed, steel pressure vessel containing nitrogen or carbon dioxide gas used to pressurize the agent tank.

Cooking Appliance: Includes fryers, griddles, ranges, upright broilers, chain broilers, natural charcoal broilers, or char-broilers (electric, lava rock, gas-radiant, or mesquite).

Cooking Area: Cooking area is defined as the maximum surface that requires protection. Each type of appliance has a defined cooking area with parameters that vary for each appliance. For example, the cooking area for a griddle is the entire flat cooking surface, while a fryer may have two areas that need consideration, depending on whether the fryer has a dripboard or not.

Conduit Offset Assembly: A pre-formed piece of conduit which can be installed between the ANSUL regulated release and the conduit to allow the wire rope for the detection, gas valve and remote manual pull station to be installed in a more convenient manner.

DEFINITION OF TERMS (Continued)

Depth: When referring to depth as a linear dimension, it is the horizontal dimension measured from front to back of the appliance or plenum.

Detector: A device which includes the detector bracket, detector linkage, and fusible link used for automatic operation of the fire suppression system.

Detector Linkage: A device used to support the fusible link.

▶ **Discharge Hose Assembly:** An agent distribution hose to be used with castered cooking appliances with castered supports to allow the movement of the appliance for service or cleaning purposes.

Distribution Piping: Piping which delivers the extinguishing agent from the tank to each discharge nozzle. See also Supply or Branch lines.

Ducts (or Duct System): A continuous passageway for the transmission of air and vapors which, in addition to the containment components themselves, may include duct fittings, dampers, duct filters, duct transitions, in-line or end-duct pollution control units (PCUs), and/or other items or air handling equipment.

▶ **Electrostatic Precipitator:** A device used to aid in the cleaning of the exhaust air. This device is normally installed at or near the base of the ventilation duct or may be included as an integral part of a pollution control unit (PCU).

Expellant Gas Line: Piping and/or hose which supplies the nitrogen or carbon dioxide gas from the regulated release assembly/regulated actuator assembly to each agent tank.

▶ **Flexible Conduit:** A flexible means to route stainless steel cable from the ANSUL AUTOMAN Regulated Release to a manual pull station or mechanical gas valve.

Flow Number: Term used in system design to describe the flow capacity of each nozzle used to determine the quantity of tanks needed to cover a certain group of hazards.

▶ **Fusible Links:** A fixed temperature heat detecting device employed to restrain the operation of a mechanical control until its designed temperature is reached, allowing separation of the link and system operation.

▶ **Gas Valve:** An electrically or mechanically operated device used to shut off the gas supply to the cooking equipment when the system is actuated.

Gas Valve Air Cylinder: An air cylinder, located in the release mechanism, which operates pneumatically to mechanically unlatch a mechanical gas valve actuator, causing the gas valve to close upon system actuation.

High Proximity: Indicates a distance (vertically) between the nozzle tip and the surface of the appliance being protected.

▶ **Hood:** A device provided for cooking appliances to direct and capture grease-laden vapors and exhaust gases from cooking appliances. It shall be constructed in a manner which meets the requirements of NFPA 96.

Liquid Agent: A potassium-based solution used for the knock-down and suppression of fire.

Low Proximity: Indicates a distance (vertically) between the nozzle tip and the surface of the appliance being protected.

Maximum Length of Cooking Appliance: The maximum dimension, on any side, which may be protected by one nozzle.

Maximum Piping: Specified length of piping and number of fittings which must not be exceeded for each system.

Medium Proximity: Indicates a distance (vertically) between the nozzle tip and the surface of the appliance being protected.

Minimum Piping: Minimum length of distribution piping required between the agent tank outlet and any nozzle protecting a griddle, range, or fryer.

Nozzle: A device designed to deliver the liquid agent with a specific flow rate and stream pattern.

Overlapping Protection: When discharge nozzles are spaced equally apart over one or more appliances requiring protection. Nozzles used in this manner provide area protection of eligible appliances within the protected area. Two types of overlapping protection is available: full hood continuous protection and group protection. Overlapping protection is in addition to appliance specific coverages.

Plenum: The space enclosed by the filters and the portion of the hood above the filters.

Pre-engineered System: NFPA 17A defines a pre-engineered system as one which has "...predetermined flow rates, nozzle pressures, and quantities of liquid agent." The R-102 system, as prescribed by UL (Underwriter's Laboratories), has specific pipe sizes, maximum and minimum pipe lengths and numbers of fittings, and number and types of nozzles. The hazards protected by this system are also specifically limited as to type and size by UL based upon actual fire tests. All limitations on hazards that can be protected and piping and nozzle configurations are contained in the R-102 installation and maintenance manual which is part of the UL listing.

Pulley Elbow: A device used to change the direction of the wire rope which runs between: the regulated release mechanism and the detectors, the regulated release mechanism and the mechanical gas valve, and/or the regulated release mechanism and the remote manual pull station.

Pulley Tee: A device used to change the direction of two wire ropes which run from a regulated release or a regulated actuator to two remote manual pull stations, or from two regulated releases or regulated actuators to a single mechanical gas valve or from one regulated release or regulated actuator to two gas valves.

Regulated Actuator Assembly: An assembly which contains the regulator, pneumatic actuator, agent tank, and expellant gas hose within a metal enclosure. This assembly is used to pressurize additional agent tanks in a multiple tank system.

Regulated Release Mechanism: An enclosed device within the ANSUL AUTOMAN regulated release assembly which releases the expellant gas, activates alarms, and/or shuts off other devices when signaled automatically by a detector or manually with a remote pull station.

Regulator: A device used to regulate the pressure from the nitrogen cartridge into the agent tank(s) when the system is actuated.

Remote Manual Pull Station: A device which provides manual actuation of the system from a remote location.

Salamander Broiler: A broiler very similar in design to the upright broiler. A salamander broiler is used for general broiling of meats and fish, toasting, and holding/warming foods. Most contain a removable grease drip tray.

▶ **Series Detector:** Any detector located in-line between the regulated release assembly and the terminal detector.

Silicone Lubricant: A heat-resistant organic compound used to lubricate O-rings, rubber and mechanical components.

Supply Line: The agent distribution piping which extends from the agent tank outlet and serves as a manifold for the branch lines.

DEFINITION OF TERMS (Continued)

Terminal Detector: The last in a series of detectors, or the only detector used in a single-detector system. This detector is thus named because it is at the point at which the wire rope ends, or “terminates.” There is only one terminal detector per detection system.

Transition: An extension of the hood or canopy which allows for the smooth transmission of gases, air, and vapors between the hood opening and the base of the ventilation duct.

Vent Plug: A device used to prevent pressure build-up within the agent tank or agent distribution lines due to temperature fluctuations.

SECTION I – GENERAL INFORMATION
UL EX3470 ULC EX3470 Page 1-4
REV. 0 7-1-09

NOTES:

TOTAL SYSTEM

► There are four types of R-102 Restaurant Fire Suppression Systems:

1. Single-tank System
2. Double-tank System
3. Three-tank System (1 Cartridge)
4. Multiple Tank System (Three Tanks or More – Multiple Cartridges)

The type of system required for the particular installation will be determined through the guidelines covered in "System Design." Additional equipment which may be required to complete the system design is explained in the "System Components" section. Additional devices covered are: remote manual pull stations, mechanical and electrical gas shut-off valves, electrical switches, and pressure switches.

Single-Tank System

The R-102 single-tank system is available with a stainless steel enclosure and consists of:

1. ANSUL AUTOMAN Regulated Release Assembly (Electrical or Mechanical)
2. Nitrogen Cartridge and/or Carbon Dioxide Cartridge
3. ANSULEX Low pH Liquid Fire Suppressant
4. Discharge Nozzles
5. Detection Components
6. Additional Devices (As Required)

The regulated release assembly contains the regulated release mechanism, agent tank, expellant gas hose for agent tank hookup, and enclosure knockouts to facilitate installing detection system and additional equipment. Refer to "System Components" section for individual component descriptions.

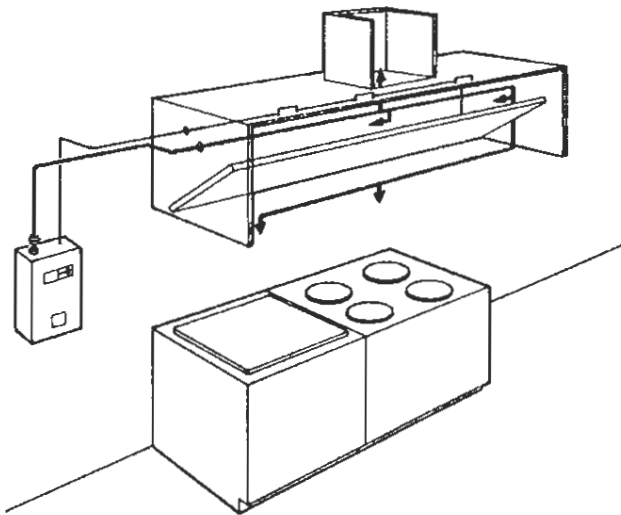

FIGURE 1
000133

Double-Tank System

► The R-102 double-tank system is available with stainless steel enclosures and consists of:

1. ANSUL AUTOMAN Regulated Release Assembly (Electrical or Mechanical)
2. Nitrogen Cartridge and/or Carbon Dioxide Cartridge
3. ANSULEX Low pH Liquid Fire Suppressant
4. Enclosure or Bracket Assembly
5. Discharge Nozzles
6. Detection Components
7. Additional Devices (As Required)

The regulated release assembly contains the regulated release mechanism, agent tank, expellant gas hose for agent tank hookup, and enclosure knockouts to facilitate installing expellant piping, detection system, and additional equipment.

The enclosure or bracket assembly is mounted separately but within the guidelines of the regulated release assembly expellant gas piping requirements to ensure simultaneous actuation of the system. Refer to "System Components" section for individual component descriptions.

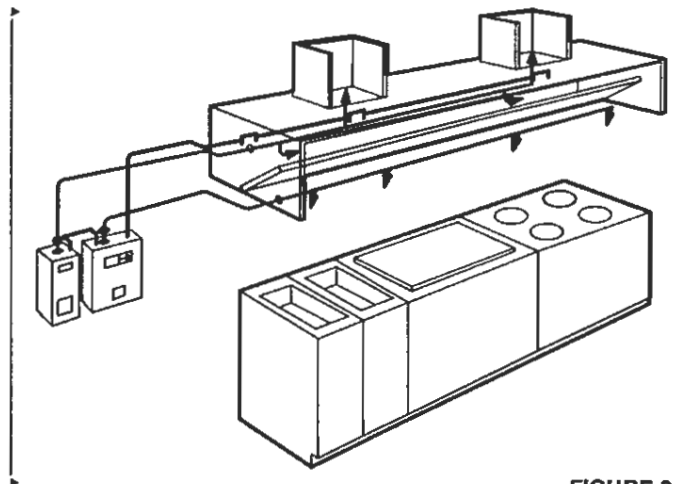

FIGURE 2
008321

TOTAL SYSTEM (Continued)

▶ **Three-Tank System (1 Cartridge with Three (3) 3.0 Gal Tanks ONLY)**

The R-102 three-tank system is available with stainless steel enclosures and consists of:

1. ANSUL AUTOMAN Regulated Release Assembly (Electrical or Mechanical)
2. Double Tank Enclosure Assembly
3. Nitrogen Cartridge
4. ANSULEX Low pH Liquid Fire Suppressant
5. Discharge Nozzles
6. Detection Components
7. Additional Devices (As Required)

The regulated release assembly contains the regulated release mechanism, agent tank, expellant gas hose for agent tank hookup, and enclosure knockouts to facilitate installing expellant piping, detection system, and additional equipment.

The double tank enclosure assembly is mounted separately but within the guidelines of the regulated release assembly expellant gas piping requirements to ensure simultaneous actuation of the system. Refer to "System Components" section for individual component descriptions.

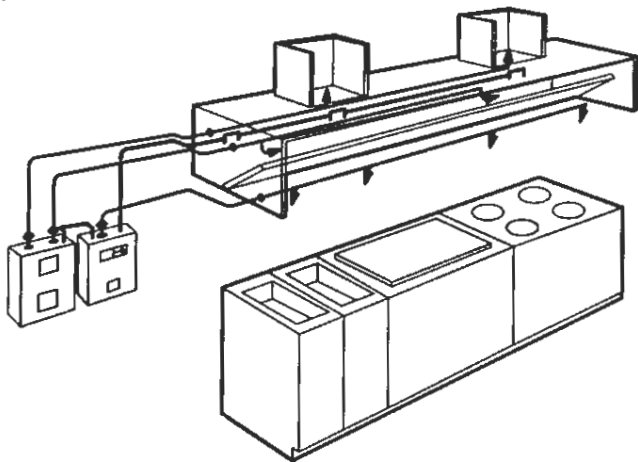

FIGURE 3
008322

▶ **Multiple Tank System (Three (3) Tanks or More – Multiple Cartridges)**

The R-102 multiple-tank system is available with stainless steel enclosures and consists of:

- ▶ 1. ANSUL AUTOMAN Regulated Release Assembly (Electrical or Mechanical) or ANSUL AUTOMAN Remote Release Assembly(ies)
- ▶ 2. Nitrogen Cartridge(s) and/or Carbon Dioxide Cartridge(s)
3. Regulated Actuator Assembly(ies)
4. ANSULEX Low pH Liquid Fire Suppressant
5. Enclosure or Bracket Assembly(ies)
6. Discharge Nozzles
7. Detection Components
8. Additional Devices (As Required)

The regulated release assembly contains the regulated release mechanism, agent tank, expellant gas hose for agent tank hookup, and enclosure knockouts to facilitate installing actuation piping, expellant piping, detection system, and additional equipment.

▶ The remote release assembly(ies) is used in large systems or multi-hood systems to actuate regulated actuator assembly(ies) ONLY. The remote release assembly contains a release mechanism (unregulated), with enclosure knockouts to facilitate installing the actuation piping, expellant piping, detection system, and additional equipment.

Each regulated actuator assembly is mounted separately but within the guidelines of the regulated release assembly actuation/expellant gas piping requirements to ensure simultaneous actuation of the system. The assembly contains the pneumatic actuator, regulator, agent tank, expellant gas hose for agent tank hookup, and enclosure plugs to facilitate installing expellant piping.

Each enclosure or bracket assembly is mounted separately but within the guidelines of the regulated release assembly or regulated actuator assembly expellant gas piping requirements to ensure simultaneous actuation of the system. Refer to "System Components" section for individual component descriptions.

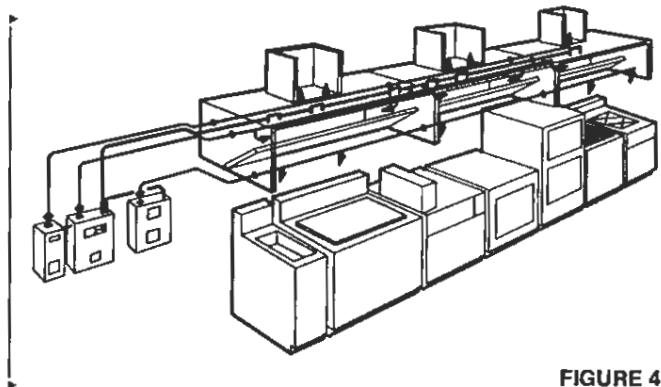

FIGURE 4
008323

EXTINGUISHING AGENT

ANSULEX Low pH Liquid Fire Suppressant (1.5 gallon – Part No. 79694 or 3.0 gallon – Part No. 79372) is a potassium-based solution designed for fast knock-down and suppression of grease-related fires. The agent is shipped in plastic containers which provide one complete tank charge. (Refer to Section V, Page 5-2.1, for maximum agent fill capacity.) Agent storage life expectancy is twelve years and can be stored at a temperature of -40 °F to 130 °F (-40 °C to 54 °C). **Note: When installing agent in R-102 system, temperature range is 32 °F (0 °C) to 130 °F (54 °C).** The distributor must record the batch numbers and date of shipment receipt to be filed with each installation record.

*ANSULEX™ LOW pH LIQUID FIRE SUPPRESSANT

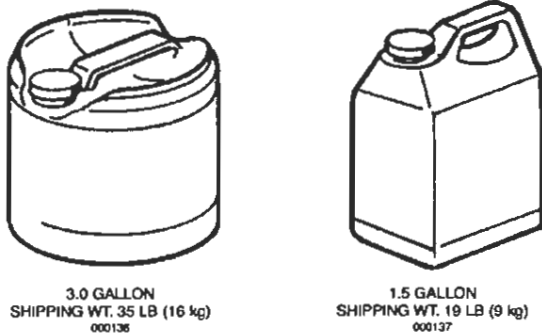

FIGURE 1

REGULATED RELEASE ASSEMBLY (MECHANICAL)

The ANSUL AUTOMAN Regulated Mechanical Release Assembly (Part No. 429853) contains the regulated release mechanism, expellant gas hose for agent tank hookup, and enclosure knockouts to facilitate installing actuation piping; expellant piping; detection system; and additional equipment. This regulated release assembly is used in single, double, and multiple-tank systems and must be mounted to a rigid surface. The release mechanism can be used to interconnect both the actuation and expellant gas lines as required per system design. The regulator is designed to allow a constant flow of gas into the tank at 110 psi (7.6 bar) when the system is actuated. The agent tank must be ordered separately.

In single, double, and multiple-tank systems, the provided expellant gas hose connects the agent tank to the bottom outlet of the regulator. In double and multiple-tank system configurations, the back outlet of the regulator is used as an expellant gas feed for one additional tank-enclosure or tank-bracket hookup. The enclosure contains the required knockouts to facilitate this connection. If a pressure switch is to be attached to the regulator, additional fittings are required.

The tank is mounted within the enclosure. The tank contains an adaptor/tube assembly with a burst disc union. The burst disc helps prevent siphoning of the agent up the pipe due to significant temperature fluctuations in the area where the tank is located. The tank is stainless steel and, under normal conditions, requires hydrostatic testing every twelve years.

The detection and additional equipment required per system design are connected to the release mechanism. The enclosure contains knockouts to facilitate detection and additional hookups.

The system can be actuated automatically or manually. Automatic actuation occurs when a fusible link within the detection system separates in a fire condition. Manual actuation of the system occurs when personnel pull on the remote manual pull station pull ring.

"ANSUL AUTOMAN" REGULATED RELEASE ASSEMBLY (MECHANICAL)

NOTE: AGENT TANK MUST BE ORDERED SEPARATELY OR SEE PAGE 3-4

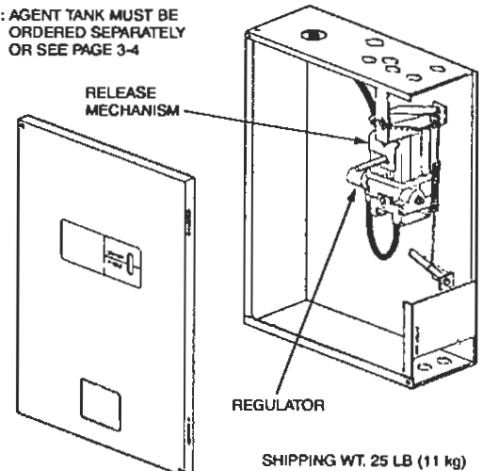

FIGURE 2
000138

REGULATED RELEASE ASSEMBLY (ELECTRICAL)

The ANSUL AUTOMAN Regulated Electrical Release Assembly (Part No. 429856) is identical to the mechanical version except it also contains a factory installed 120 VAC solenoid and electrical switch.

The solenoid is used to provide electrical actuation of the release mechanism. The electric switch is used to protect the solenoid by opening the circuit to the solenoid once the system is fired. Additional electrical switches can be added as required for automatic equipment and gas shut-off accessories, as well as initiating audible and visual alarms.

"ANSUL AUTOMAN" REGULATED RELEASE ASSEMBLY (ELECTRICAL)*

NOTE: AGENT TANK MUST BE ORDERED SEPARATELY OR SEE PAGE 3-4

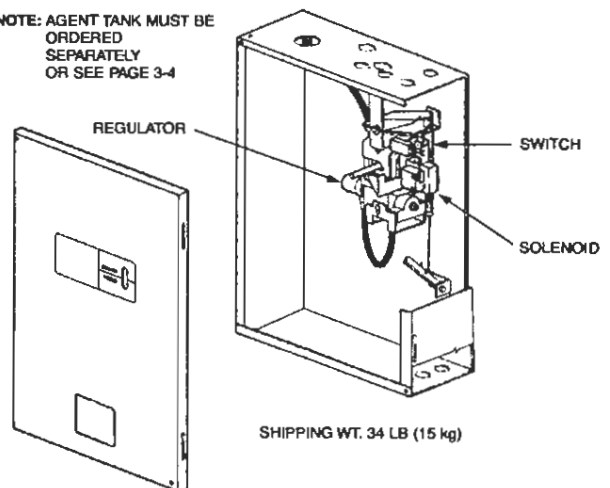

FIGURE 3
000139

* NOTE: ANSUL AUTOMAN Regulated Electrical Release, Part No. 429856, is not intended to be used with electric detection.

REMOTE MECHANICAL RELEASE

The Remote Mechanical Release, Part No. 433485, is used to actuate up to five (5) R-102 regulated actuators. The remote mechanical release utilizes a 101-10 carbon dioxide cartridge as the actuation pressure to operate the regulated actuators. The release is housed in a stainless steel enclosure.

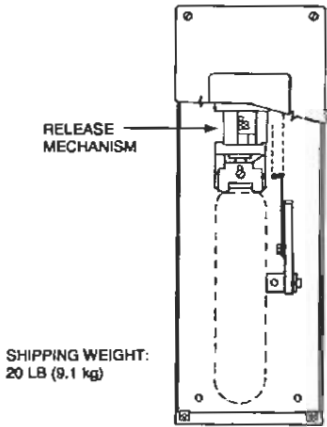

FIGURE 4
007498

SINGLE TANK ENCLOSURE ASSEMBLY

The Single Tank Enclosure Assembly (Part No. 429870) is used in double and multiple-tank systems and must be mounted to a rigid surface near the regulated release or regulated actuator assembly its expellant gas line will be connected to.

The enclosure is designed for mounting either a 1.5 gallon (Part No. 429864) or a 3.0 gallon tank (Part No. 429862) in a minimum amount of space.

ENCLOSURE ASSEMBLY

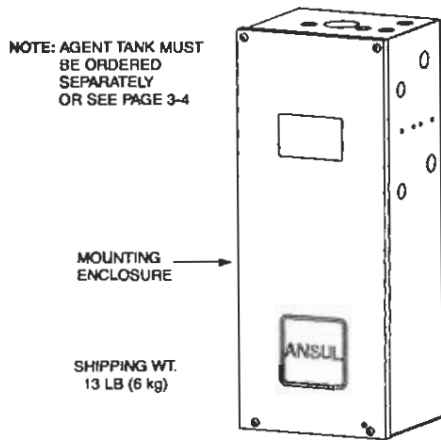

FIGURE 5
000142

RED PAINTED BRACKET ASSEMBLY

The Bracket Assembly (Part No. 429878) is used in double and multiple-tank systems and must be mounted to a rigid surface near the regulated release assembly or regulated actuator assembly that its expellant gas line will be connected to.

The tank bracket is constructed of mild steel and painted red. It is designed for mounting the tank in a minimum amount of space. The Bracket Assembly can only be utilized with 3.0 gallon tanks (Part No. 429862).

BRACKET ASSEMBLY

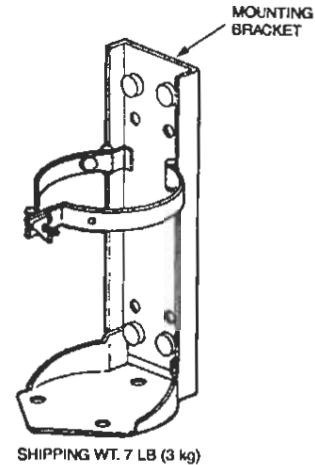

FIGURE 6
000141

REGULATED ACTUATOR ASSEMBLY

The Regulated Actuator Assembly (Part No. 429850) contains the regulator, pneumatic actuator, expellant gas hose for agent tank hookup, and enclosure knockouts to facilitate installing expellant piping. This assembly is used in multiple-tank systems and must be mounted to a rigid surface.

The regulator contains two outlets 135° apart. One outlet is used to interconnect the expellant gas hose to the enclosed agent tank. The other outlet connects an expellant gas line to an additional enclosure or bracket assembly. The regulator is designed to allow a constant flow of nitrogen into each agent tank connected (two tanks maximum) at 110 psi (7.6 bar).

The pneumatic actuator is designed to puncture the expellant gas cartridge seal upon receiving pressure from the regulated release assembly actuation piping. The enclosure contains a knockout to facilitate distribution piping hookup.

REGULATED ACTUATOR ASSEMBLY

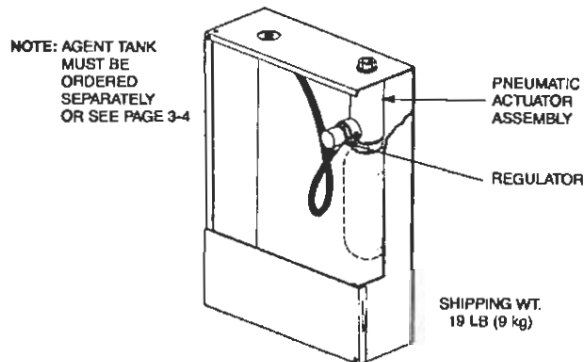

FIGURE 7
000143

AGENT TANK ASSEMBLY

The agent tank shipping assembly (3-Gallon, Part No. 429862, and 1.5 Gallon, Part No. 429864) consists of a stainless steel tank and an adaptor/tube assembly. The adaptor/tube assembly contains a burst disc. The burst disc prevents agent leakage due to significant temperature fluctuations in the area where the tank is located. Under normal conditions, the tank requires hydrostatic testing every twelve years. The date of manufacture is stamped on the tank nameplate.

The tank is shipped uncharged and must be filled with only ANSULEX Low pH Liquid Fire Suppressant during installation.

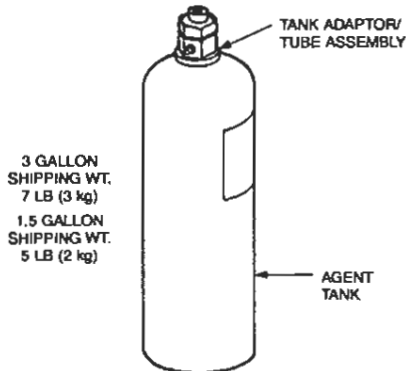

FIGURE 8
000140

OEM RELEASE/BACKET ASSEMBLY (FOR OEM IN-CABINET USE ONLY)

The OEM Regulated Mechanical Release/Bracket Assembly, Part No. 79493, contains the same regulated release mechanism as the standard ANSUL AUTOMAN Regulated Release Assembly. The OEM Regulated Electrical Release/Bracket Assembly, Part No. 418054*, is identical to the mechanical version except it contains a factory installed 120 VAC solenoid and electrical switch. These release/bracket assemblies must be installed in a suitable equipment enclosure either horizontally or vertically. They contain all the necessary mounting and conduit holes needed to fully install the assembly. The agent tank is installed separately and need not be bracketed once it is piped and filled. **Note:** OEM Release/Bracket Assembly must be installed high enough in cabinet so that there is sufficient room to install and remove cartridge.

* Note: OEM Regulated Electrical Release/Bracket Assembly, Part No. 418054, is not intended to be used with electric detection.

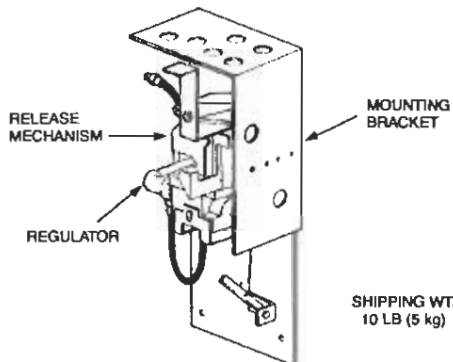

FIGURE 9
000144

OEM REGULATED ACTUATOR ASSEMBLY

The OEM Regulated Actuator Assembly, Part No. 418691, includes the regulator, pneumatic actuator, expellant gas hose and OEM bracket. Also available is an OEM Regulated Actuator Assembly with all the above mentioned components except for the bracket. This assembly is Part No. 418522.

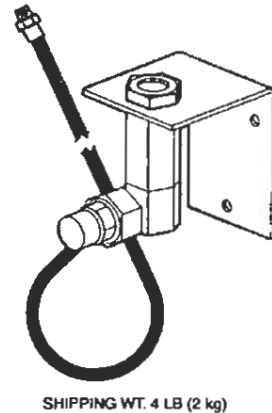

FIGURE 10
002225

TWO TANK ENCLOSURE ASSEMBLY

The Two Tank Enclosure Assembly, Part No. 429872, consists of two expellant gas hoses, two grommets, and the mounting enclosure. The assembly is used in 9 gallon systems. It can be coupled with a 3-gallon regulated release assembly or a 3-gallon regulated actuator assembly to give a total of 9 gallons of agent. Agent tanks must be ordered separately.

The tank enclosure is designed to mount in a minimum amount of space.

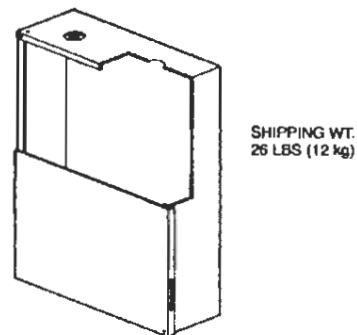
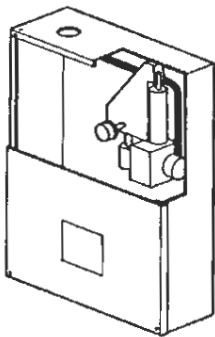

FIGURE 11
002277

24 VDC REGULATED RELEASE ASSEMBLY (ULC APPROVED ONLY)

The 24 VDC Regulated Release Assembly, Part No. 429859, is used where electric, thermostat detection is required via the use of a releasing control unit. This assembly consists of a 24 VDC ANSUL AUTOMAN II-C regulated release mechanism, expellant gas hose, and enclosure knockouts to facilitate installing actuation piping, expellant piping, detection system, and additional equipment. Agent tank must be ordered separately.

The system can be actuated automatically or manually. Automatic actuation occurs when the control panel receives a signal from the detection circuit. The panel then sends an electrical signal to the 24 VDC regulated release, causing it to actuate. When actuation occurs, the gas cartridge is punctured, pressurizing the agent tank and discharging the agent through the distribution piping. Manual actuation of the system occurs when personnel pull on the remote manual pull station pull ring.



NOTE: AGENT TANK MUST BE ORDERED SEPARATELY

SHIPPING WT.
34 LB (15 kg)

FIGURE 12
00279

ADDITIONAL SHIPPING ASSEMBLIES

Several complete shipping assemblies are available containing both the release or actuator mechanism and the agent tank. When ordering a complete shipping assembly, order the following part numbers:

Part No.	Description	Shipping Wt.	
		lb	(kg)
430299	3.0 Gallon Mechanical Release Shipping Assembly including: 429853 Mechanical Regulated Release Assembly 429862 3.0 Gallon Tank Assembly	33	(15)
430300	1.5 Gallon Mechanical Release Shipping Assembly including: 429853 Mechanical Regulated Release Assembly 429864 1.5 Gallon Tank Assembly	30	(14)
430309	3.0 Gallon Regulated Actuator Shipping Assembly including: 429850 Regulated Actuator Assembly 429862 3.0 Gallon Tank Assembly	36	(16)
430316	1.5 Gallon Stainless Steel Enclosure Shipping Assembly including: 429870 Single Tank Mounting Box Assembly 429864 1.5 Gallon Tank Assembly 418511 Hose Assembly	18	(8)
430317	3.0 Gallon Stainless Steel Enclosure Shipping Assembly including: 429870 Single Tank Mounting Box Assembly 429862 3.0 Gallon Tank Assembly 418511 Hose Assembly	20	(9)
430324	6.0 Gallon Stainless Steel Enclosure Shipping Assembly including: 429872 Two Tank Mounting Box Assembly 429862 3.0 Gallon Tank Assembly (2)	40	(18)
430332	3.0 Gallon Mounting Bracket Shipping Assembly including: 429878 3.0 Gallon Mounting Bracket Assembly 429862 3.0 Gallon Tank Assembly	20	(9)

GAS CARTRIDGES

The R-102 system uses gas cartridges to store nitrogen or carbon dioxide expellant gases under pressure until the system is actuated, at which time the cartridge seal is punctured and the released gas expels liquid agent from one or more tanks through the discharge piping and out the discharge nozzles.

Four nitrogen gas cartridges and three carbon dioxide gas cartridges are available as shown in Figure 13.

Cartridges noted as TC/DOT are both Transport Canada (TC) and Department of Transportation (DOT) approved. Cartridges noted as DOT are Department of Transportation approved only.

Cartridge selection options are provided in Section IV under Tank and Cartridge Requirements.

NITROGEN GAS CARTRIDGES

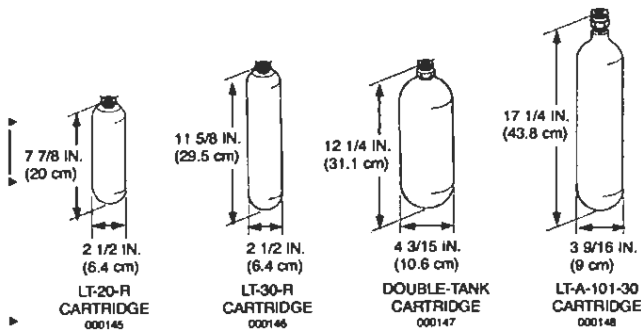

CARBON DIOXIDE CARTRIDGES

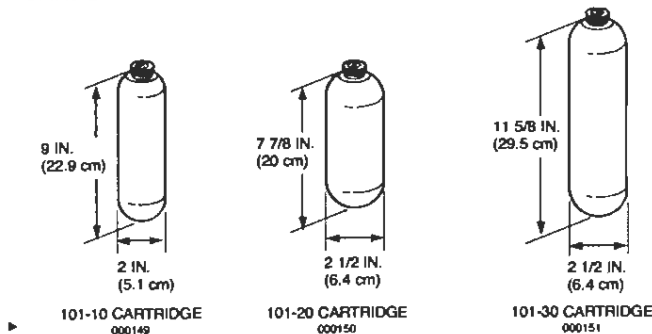

FIGURE 13

Additional cartridge shipping assemblies are available for European and Australian requirements.

Cartridge Description	European Part No.	Australian Part No.	TC/DOT Part No.
LT-20-R	428440	428948	423429
LT-30-R	428441	426553	423435
Double Tank	428446	426563	423493
LT-A-101-30	428442	426555	423491
101-10 – CO ₂	428443	N/A	423439
101-20 – CO ₂	428445	N/A	423441
101-30 – CO ₂	428444	N/A	423443

Note: For 101-10 cartridge, Part No. 15850 is DOT only.

NOZZLES

There are 11 types of discharge nozzles each designed to distribute the liquid agent in a uniform pattern throughout the hazard area:

1. 1W Nozzle
2. 1N Nozzle
3. 1/2N Nozzle
4. 3N Nozzle
5. 2W Nozzle
6. 230 Nozzle
7. 245 Nozzle
8. 260 Nozzle
9. 290 Nozzle
10. 2120 Nozzle
11. 1F Nozzle

Although these nozzles are similar in appearance and have certain common parts, the tip of each nozzle is designed for a specific application and must only be used in those areas. See Nozzle Application Chart in Section IV – System Design, for individual nozzle usage.

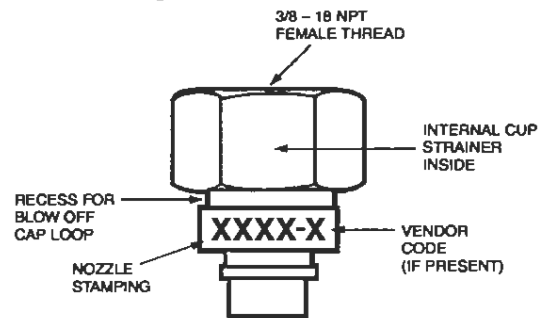

FIGURE 14
000002

Nozzle Identification Chart

Note: See Component Index for nozzle package shipping assembly by part numbers.

Nozzle Type	Nozzle Part No.	Nozzle* Stamping	Nozzle Flow No.	Nozzle Material
1W Nozzle	419336	1W**	1	Chrome-Plated Body
1N Nozzle	419335	1N**	1	Chrome-Plated Body
1/2N Nozzle	419334	1/2N	1/2	Chrome-Plated Body
3N Nozzle	419338	3N	3	Chrome-Plated Body
2W Nozzle	419337	2W	2	Chrome-Plated Body
230 Nozzle	419339	230	2	Chrome-Plated Body
245 Nozzle	419340	245	2	Chrome-Plated Body
260 Nozzle	419341	260	2	Chrome-Plated Body
290 Nozzle	419342	290	2	Chrome-Plated Body
2120 Nozzle	419343	2120	2	Chrome-Plated Body
1F Nozzle	419333	1F	1	Chrome-Plated Body

* Nozzle stamping may contain an additional letter indicating a vendor's code.
 **Stainless steel versions are available in the 1W nozzle (Part No. 432527) and the 1N nozzle (Part No. 435672).

SILICONE LUBRICANT

Dow Corning Compound 111, Part No. 78112, is available in a 5.3-ounce tube. Compound has excellent qualities for sealing and lubricating system components.

SWIVEL ADAPTOR

- ▶ The Swivel Adaptor Assembly consists of a swivel nut, swivel body and swivel ball. All are chrome-plated. The swivel adaptor allows any nozzle to be rotated approximately 30° in all directions. Swivel Adaptors must be ordered as a Swivel Adaptor Shipping Assembly, Part No. 423572, which contains 25 Swivel Adaptors or
- ▶ Part No. 419385, which contains 9 Swivel Adaptors.

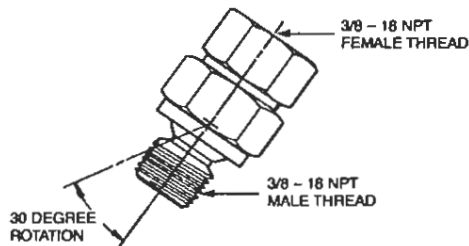

FIGURE 15
000003

RUBBER BLOW-OFF CAPS

- ▶ The Rubber Blow-Off Cap helps keep the orifice of the nozzle free of grease or other substances that could interfere with agent distribution. A retaining strap attaches the blow-off cap to the nozzle. Rubber Blow-Off Caps must be ordered as a Shipping Assembly, Part No. 77695, which contains 50 blow-off caps, or Part No. 77411, which contains 12 blow-off caps.

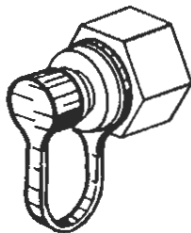

FIGURE 16
000009

CB METAL BLOW-OFF CAP

The CB Metal Blow-off Cap Package, Part No. 433208, is used for all high temperature environments. The metal blow-off cap contains a special O-ring placed inside the cap which integrates with the nozzle to create a seal and to help hold the blow-off cap in position.

The CB Metal Blow-Off Cap Package, Part No. 433208, contains 10 blow-off caps.

Also available is a 10 pack of CB Stainless Steel Blow-Off Caps, Part No. 434707.

- ▶ A 10 pack of Metal Blow-Off Cap O-rings, Part No. 551530, is also available.

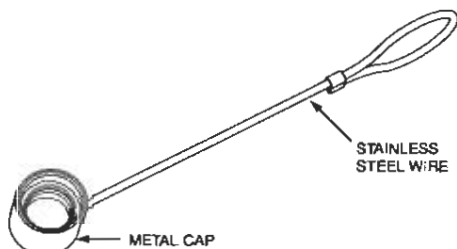

FIGURE 17
007633

CONDUIT OFFSET ASSEMBLY

- ▶ The conduit offset assembly, Part No. 435961, is used to change direction of the wire rope on detection, mechanical gas valve, and remote pull station lines. The conduit offset assembly can only be used in the area where the conduit attaches to the regulated release assembly. When using the conduit offset assembly, the maximum number of pulley elbows is still allowed. The Conduit Offset Shipping Assembly, Part No. 436063, consists of 6 conduit offsets.

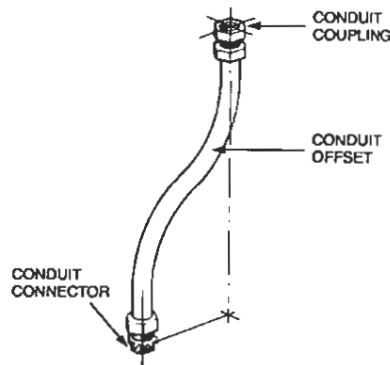

FIGURE 18
000150

“QUIK-SEAL” ADAPTOR

- ▶ The “Quik-Seal” adaptor is a listed mechanical bulkhead fitting that produces a liquid-tight seal around both distribution piping and detection conduit which runs through restaurant hoods and ducts. The “Quik-Seal” adaptor accepts threaded pipe or conduit. The adaptor is available for 1/4 in. (Part No. 78196), 3/8 in. (Part No. 77285), 1/2 in. (Part No. 77287), or 3/4 in. (Part No. 77289) pipe or conduit sizes. When using with EMT conduit, a conduit connector must be installed in each end of the adaptor. The “Quik-Seal” Adaptor Shipping Assembly must be ordered as stated below:

Size	Shipping Assembly Part No.	Qty.	Hole Size Required
1/4 in.	78196	24	3/4 in.
3/8 in.	77285	24	1 1/8 in.
1/2 in.	77287	24	1 1/8 in.
3/4 in.	77289	24	1 3/8 in.

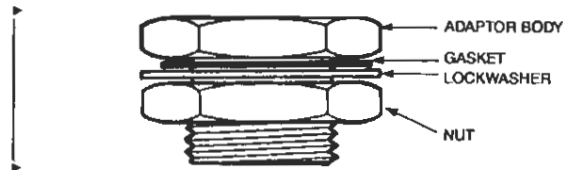

FIGURE 19
000154

“COMPRESSION-SEAL” ADAPTOR

This adaptor is a mechanical bulkhead fitting that produces a liquid-tight seal around pipe and conduit when installing distribution piping and detection conduit through restaurant hoods and ducts. The “Compression-Seal” adaptor is a straight-through design requiring no cutting or threading of conduit or pipe. The adaptor is available for pipe sizes of 1/4 in. (Part No. 79149), 3/8 in. (Part No. 79151), 1/2 in. (Part No. 79147), and EMT conduit size of 1/2 in. (Part No. 79153). Each “Compression-Seal” Adaptor Shipping Assembly must be ordered as stated below:

Size	Shipping Assembly Part No.	Qty.	Hole Size Required
1/4 in. Pipe / 1/2 in. tube	79149	24	3/4 in.
3/8 in. Pipe / 5/8 in. tube	79151	24	1 1/8 in.
1/2 in. Pipe	79147	24	1 1/8 in.
1/2 in. EMT Conduit	79153	24	1 1/8 in.

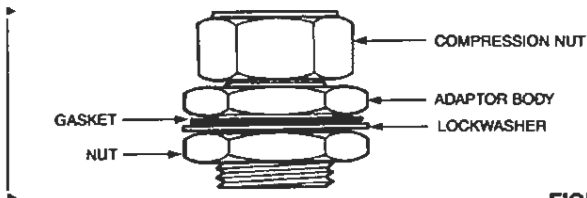

FIGURE 20
000156

“HOOD SEAL” ADAPTOR ASSEMBLY

This adaptor is a mechanical bulkhead fitting that produces a liquid-tight seal around 1/2 in. EMT conduit when installing the detection line through restaurant hoods and duct. The adaptor accepts a high temperature pulley elbow and, when used, correctly positions the elbow or conduit in line with the conduit adaptor hole in the detector bracket. The “Hood Seal” eliminates the need for multiple elbows when penetrating the top of a hood when installing the detection line. “Hood Seal” Adaptors are available in quantities of 6 as Shipping Assembly Part No. 423253.

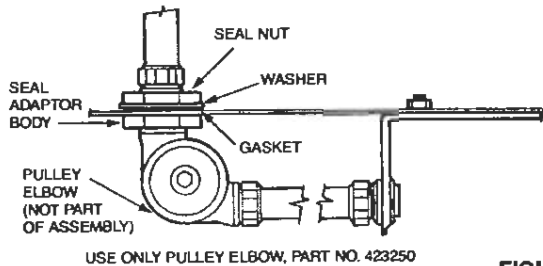

FIGURE 21
000156

REDUCING COUPLING

The reducing coupling, Part No. 436228, is made of stainless steel material with 3/8 in. x 1/2 in. NPT inlet threads. If necessary, the reducing coupling can be utilized when installing the Agent Distribution Hose Line Kit, Part No. 435982. Two couplings are required per Agent Distribution Hose.

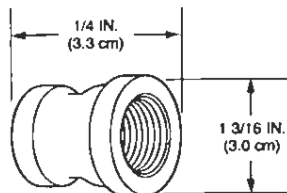

FIGURE 22
006324

COCKING LEVER/LOCK BAR

The cocking lever is a component required to cock (arm) both the mechanical/electrical ANSUL AUTOMAN release and the mechanical gas valve. After the ANSUL AUTOMAN is cocked (armed), the lock bar must be inserted to eliminate the accidental firing of the release mechanism. These components are available as either an individual shipping assembly or a shipping assembly containing both. Listed below are the various shipping assembly part numbers.

Part No.	Description
435603	Short Handle Cocking Lever only (Mechanical/Electrical ANSUL AUTOMAN)
435790	Short Handle Cocking Lever with Lock Bar (Mechanical/Electrical ANSUL AUTOMAN)
14995	Long Handle Cocking Lever only (Mechanical/Electrical ANSUL AUTOMAN)
15618	Long Handle Cocking Lever with Lock Bar (Mechanical/Electrical ANSUL AUTOMAN)
26310	Cocking Lever only (ANSUL AUTOMAN II-C)
416018	Cocking Lever only (Mechanical Gas Valve)
14985	Lock Bar

Short Handle Cocking Lever

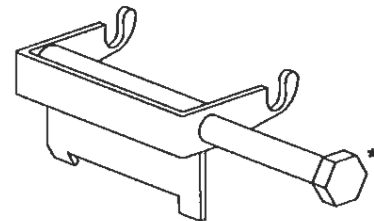

*Requires a crescent wrench or open end/box wrench

Long Handle Cocking Lever

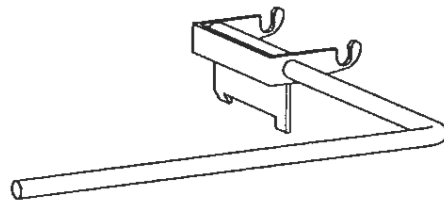

Lock Bar

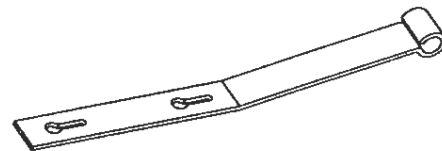

FIGURE 23
006325

DETECTORS

The detector consists of three basic components: the bracket, linkage, and fusible link. (Fusible links are not included and must be ordered separately.) The bracket holds the entire assembly to the mounting surface. The linkage is used to support the fusible link. The fusible link is designed to separate at a specific temperature and release the wire rope, thereby actuating the regulated release mechanism.

- ▶ The scissor style detector allows the wire rope to be strung completely through the detection system conduit and brackets first and the detector linkage assemblies are then clipped on later.
- ▶ The detector consists of two types of assemblies:
- ▶ **The Terminal Detector (Part No. 435546)** includes a test link and is placed last in a series of detectors. This detector is sometimes referred to as the end-of-line detector and is thus named because it is at the point at which the wire rope "terminates," or is anchored at the detector bracket. Only one terminal detector is required per detection system.
- ▶ **The Series Detector (Part No. 435547)** is any detector located in-line between the regulated release assembly and the terminal detector.
- ▶ When using Part No. 435546 and 435547 detectors, a total of 15 detectors can be in one detection system: 14 series detectors, Part No. 435547 and 1 terminal detector, Part No. 435546.
- ▶ **Note:** Series Detector, Part No. 435547, is also available as Part No. 435548, 25/Pkg.

SCISSOR STYLE – PART NO. 435546 AND 435547

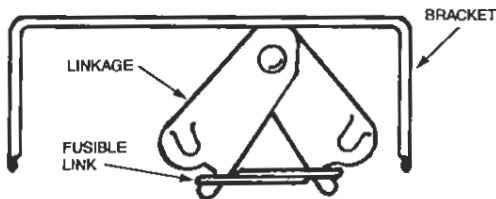
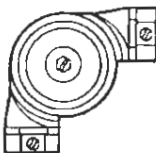

FIGURE 24
000159

PULLEY ELBOWS

There are two types of pulley elbows used to change the direction of the wire rope by 90°. ANSUL recommends for temperatures not in excess of 700 °F (371 °C). Part No. 415670 has socket ends with set screws for 1/2 in. conduit, and Part No. 423250 has compression ring ends also for 1/2 in. conduit. Pulley elbows must be ordered in quantities of 50 as Shipping Assembly Part No. 415671 (socket end type) and Part No. 423251 (compression end type).

PART NO. 415670



000160

PART NO. 423250

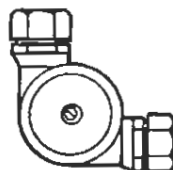

000161

FIGURE 25

PULLEY TEE

The Pulley Tee (Part No. 427929) is used to change the direction of two wire ropes by 90°. It must be used in areas where the temperatures are within the range of 32 °F to 130 °F (0 °C to 54 °C). Pulley tees can be used in mechanical gas valve actuation lines and remote manual pull station lines. Pulley tees cannot be used within a detection line.

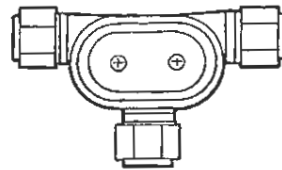

FIGURE 26
000447

STAINLESS STEEL CABLE

The 1/16 in. stainless steel cable is run from the terminal detector, through conduit, all series detectors and pulley elbows, and into the regulated release mechanism trip lever. When any fusible link separates, the tension on the cable is relaxed, and the trip lever actuates the regulated release mechanism. The cable can also be used for mechanical gas valves and remote manual pull stations. The cable is available in 50 ft (15 m) (Part No. 15821) and 500 ft (152.4 m) (Part No. 79653) lengths.

REMOTE MANUAL PULL STATION

The remote manual pull station (Part No. 434618 or 435960) is made out of a molded red composite material. The red color makes the pull station more readily identifiable as the manual means for fire suppression system operation. The pull station is compatible with the ANSUL Flexible Conduit. The molded manual pull station should be mounted at a point of egress and positioned at a height determined by the authority having jurisdiction. Trim Rings, Part No. 427074 (pack of 10), are available.

Part No. 434618 (Without Wire Rope)
Part No. 435960 (With 50 ft (15.2 m) of Wire Rope)



FIGURE 27
006326

FLEXIBLE CONDUIT

Flexible conduit allows for quicker installations and the convenience of being able to route the cable over, under and around obstacles. Flexible conduit can be used as a substitute for standard EMT conduit or can be used with EMT conduit. Flexible conduit can be used only with the Molded Manual Pull Station, Part No. 434618, and mechanical gas valve installations. The Flexible Conduit comes in a 500 ft (152.4 m) length, Part No. 434525, or together with 500 ft (152.4 m) of wire rope, Part No. 435959.

Also available is a Flexible Conduit Strain Relief (50-pack), Part No. 435979.

A 50-pack of Flexible Conduit Inserts, Part No. 434347, is also available.

Note: Flexible conduit cannot be used in detection systems.

MECHANICAL GAS VALVES

The mechanical gas valves are designed to shut off the flow of gas to the appliances upon actuation of the regulated release assembly. The valves are available in sizes of 3/4 in., 1 in., 1 1/4 in., 1 1/2 in., and 2 in. ANSUL style; and 2 1/2 in. and 3 in. ASCO style. The valves are rated for natural and LP gas. Both styles are UL Listed and includes the air cylinder, tubing, and fittings, Part No. 15733, for connection to the release mechanism.

Part No.	Description	Maximum Operating Pressure
55598	3/4 in. Gas Valve (ANSUL)	10 psi (0.69 bar)
55601	1 in. Gas Valve (ANSUL)	10 psi (0.69 bar)
55604	1 1/4 in. Gas Valve (ANSUL)	10 psi (0.69 bar)
55607	1 1/2 in. Gas Valve (ANSUL)	10 psi (0.69 bar)
55610	2 in. Gas Valve (ANSUL)	10 psi (0.69 bar)
25937	2 1/2 in. Gas Valve (ASCO)	5 psi (0.35 bar)
25938	3 in. Gas Valve (ASCO)	5 psi (0.35 bar)

Pipe Size (inches)	Flow Capacity (CFH)	BTU/HR, at 1 in. P.D.
	P.D. 1 in. WC 0.64 SP GR	0.64 SP GR 1000 BTU/ft ³ Natural Gas
3/4	751	751,000
1	1288	1,288,000
1 1/4	1718	1,718,000
1 1/2	2630	2,630,000
2	4616	4,616,000
2 1/2	5700	5,800,000
3	7100	7,300,000

To calculate gas flow for other than 1 inch p.d.:

$$\text{New cfh} = (\text{cfh at 1 inch}) \times \sqrt{\text{new p.d.}}$$

To calculate gas flow for other than 0.64 SP GR:

$$\text{New cfh} = (\text{cfh at 0.64}) \times \sqrt{\frac{0.64}{\text{New SP GR}}}$$

Valve Size	A		B		C	
	in.	(mm)	in.	(mm)	in.	(mm)
3/4 in.	3 3/4	(95.3)	6 3/8	(161.9)	5 1/2	(139.7)
1 in.	3 3/4	(95.3)	6 3/8	(161.9)	5 1/2	(139.7)
1 1/4 in.	4 7/8	(123.8)	7 3/8	(187.3)	6 3/8	(161.9)
1 1/2 in.	4 7/8	(123.8)	7 3/8	(187.3)	6 3/8	(161.9)
2 in.	5 7/8	(149.2)	7 7/8	(200.0)	6 11/16	(169.9)
2 1/2 in.	7 13/16	(198.4)	-----	-----	9 1/16	(230.2)
3 in.	7 25/32	(197.6)	-----	-----	9 1/16	(230.2)

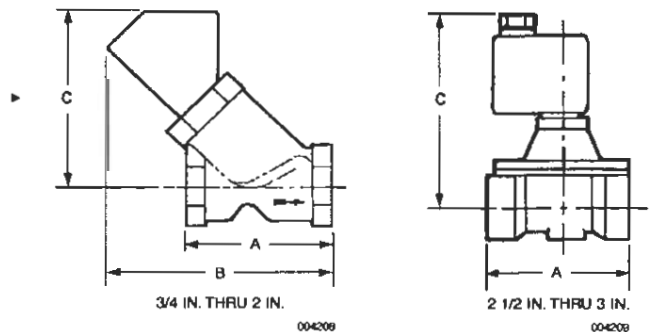

FIGURE 28

ELECTRICAL GAS VALVES

The electrical gas valves are designed to shut off the flow of either natural or LP gas to the appliances upon actuation of the regulated release assembly. The valves are available in sizes of 3/4 in., 1 in., 1 1/4 in., 1 1/2 in., 2 in., 2 1/2 in., and 3 in. The valve is held open by an energized solenoid and upon system actuation, the switch contacts in the regulated release assembly open, thus de-energizing the circuit to the gas valve solenoid, causing the valve to close. Valves are available in 120 VAC and are UL Listed.

Part No.	Description	Max. Operating Pressure
13707	3/4 in. Solenoid Gas Valve (ASCO)	25 psi (1.7 bar)
13708	1 in. Solenoid Gas Valve (ASCO)	25 psi (1.7 bar)
550360	1 1/4 in. Solenoid Gas Valve (ASCO)	25 psi (1.7 bar)
13709	1 1/2 in. Solenoid Gas Valve (ASCO)	25 psi (1.7 bar)
13710	2 in. Solenoid Gas Valve (ASCO)	25 psi (1.7 bar)
550363	2 1/2 in. Solenoid Gas Valve (ASCO)	5 psi (0.35 bar)
17643	3 in. Solenoid Gas Valve (ASCO)	5 psi (0.35 bar)

Pipe Size (inches)	Flow Capacity (CFH)	BTU/HR, at 1 in. P.D.
	P.D. 1 in. WC	0.64 SP GR
	0.64 SP GR	Natural Gas
3/4	264.96	247,500
1	1091.01	1,119,000
1 1/4	1662.49	1,730,000
1 1/2	1818.35	1,900,000
2	3117.18	3,251,000
2 1/2	6078.49	5,821,000
3	7169.51	7,430,000

To calculate gas flow for other than 1 inch p.d.:

$$\text{New cfh} = (\text{cfh at 1 inch}) \times \sqrt{\text{new p.d.}}$$

To calculate gas flow for other than 0.64 SP GR:

$$\text{New cfh} = (\text{cfh at 0.64}) \times \sqrt{\frac{0.64}{\text{New SP GR}}}$$

Valve Size	A		B	
	in.	(mm)	in.	(mm)
3/4 in.	3 5/16	(81.0)	3 5/8	(92.1)
1 in.	5	(127.0)	6 27/32	(173.8)
1 1/4 in.	7 13/16	(198.4)	7 29/32	(200.8)
1 1/2 in.	5	(127.0)	5 19/32	(142.1)
2 in.	6 3/32	(78.6)	5 15/16	(150.8)
2 1/2 in.	7 13/16	(198.4)	7 29/32	(200.8)
3 in.	7 13/16	(198.4)	7 29/32	(200.8)

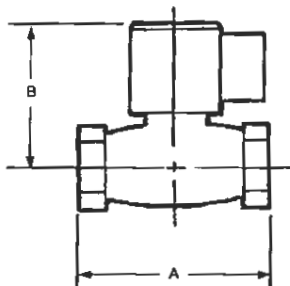

FIGURE 29
004210

MANUAL RESET RELAY

The Manual Reset Relay, Part No. 426151, is required when using an electrical gas valve shut-off system. After the electric gas valve has closed, either due to system actuation or power failure, the valve cannot be re-opened, allowing gas to flow, until the reset relay button is manually pressed, re-energizing the circuit. The reset relay is available 120 VAC. The manual reset relay is also recommended for electrical shut down.

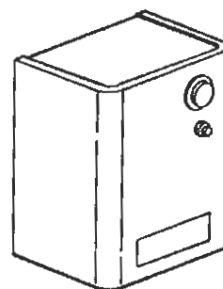

FIGURE 30
000067

ELECTRICAL SWITCHES

The electrical switches are intended for use with electric gas valves, alarms, contactors, lights, contractor supplied electric power shut-off devices and other electrical devices that are designed to shut off or turn on when the system is actuated.

Switches are available in kits: One Switch Kit, Part No. 423878, Two Switch Kit, Part No. 423879, Three Switch Kit, Part No. 423880, and Four Switch Kit, Part No. 423881. Mounting hardware and 12 in. (305 mm) long wire leads are provided with each kit. Each switch has a set of single-pole, double-throw contacts rated at:

UL/cUL/CSA Rating
 250 VAC, 21A Resistive
 250 VAC, 2 HP
 125 VAC, 1 HP

ENEC Rating
 IE4T105μ Approved
 250V, 21A Resistive
 8A Motor Load

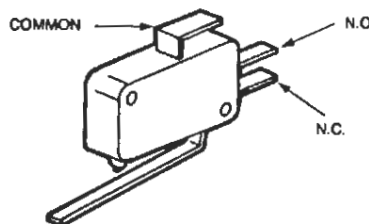

FIGURE 31
001612

ALARM INITIATING SWITCH

The Alarm Initiating Switch Kit, Part No. 428311, can be field mounted within the ANSUL AUTOMAN release. This switch must be used to close a supervised alarm circuit to the building main fire alarm panel when the ANSUL AUTOMAN release actuates. This action will signal the fire alarm panel that there was a system actuation in the kitchen area. The switch kit contains all necessary mounting components along with a mounting instruction sheet. The switch is rated 50 mA, 28 VDC.

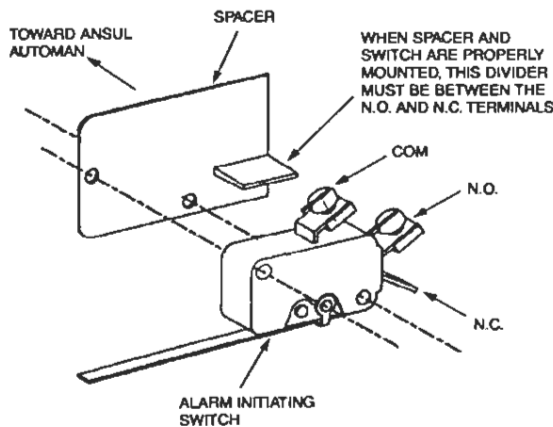

FIGURE 32
004890

REGULATOR TEST KIT

The Test Kit Assembly (Shipping Part No. 56972) is required to test the regulator setting and nitrogen flow during 12-year maintenance examinations. This will ensure that the regulator is functioning properly.

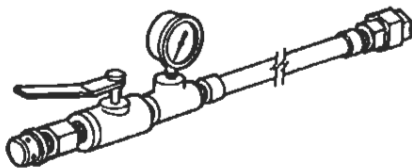

FIGURE 33
000109

FUSIBLE LINK

Select correct UL Listed fusible link(s) for installation in detector(s) according to the temperature condition chart below:

K STYLE

Fusible Link Part No.	Fusible Link Shipping Assembly Part No.	Temperature Rating	To Be Used Where Temperature Does Not Exceed
415739 (1)	415739 (1)	165 °F (74 °C)	100 °F (38 °C)
415740 (1)	415740 (1)	212 °F (100 °C)	150 °F (66 °C)
415741 (1)	415744 (25)	280 °F (138 °C)	225 °F (107 °C)
415742 (1)	415745 (25)	360 °F (182 °C)	290 °F (143 °C)
415743 (1)	415746 (25)	450 °F (232 °C)	360 °F (182 °C)

ML STYLE

Fusible Link Part No.	Fusible Link Shipping Assembly Part No.	Temperature Rating	To Be Used Where Temperature Does Not Exceed
550368 (1)	551522 (10)	165 °F (74 °C)	100 °F (38 °C)
550365 (1)	551523 (10)	212 °F (100 °C)	150 °F (66 °C)
550366 (1)	551524 (10)	280 °F (138 °C)	225 °F (107 °C)
550009 (1)	551525 (10)	360 °F (182 °C)	290 °F (143 °C)
550367 (1)	551526 (10)	450 °F (232 °C)	360 °F (182 °C)
56816 (1)	551527 (10)	500 °F (260 °C)	400 °F (204 °C)
56816 (1)	73867 (25)	500 °F (260 °C)	400 °F (204 °C)

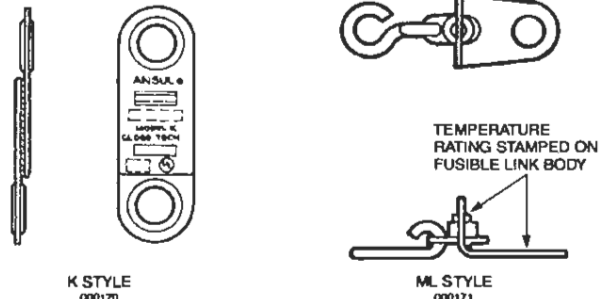

FIGURE 34

MAXIMUM REGISTERING THERMOMETER

- ▶ The Maximum Registering Thermometer, Part No. 15240, may be used to indicate the highest normal temperature for the protected area. Once this is established, the correct rated fusible link can be chosen. Other methods for determining maximum temperatures may be used.

HOSE/GROMMET PACKAGE

- ▶ The Hose/Grommet Package, Part No. 418511, consists of a 24 in. rubber hose and 2 (two) grommets. This package is required when expellant gas hose is routed outside the ANSUL AUTOMAN Regulated Release, Regulated Actuator, and/or tank enclosure assemblies.

IN-LINE BURST DISC ASSEMBLY (MANIFOLDED SYSTEMS ONLY)

The in-line burst disc assembly is required to eliminate the siphoning of the agent up the pipe during extreme temperature variations. In addition to eliminating the siphoning effect, the common in-line burst disc assembly eliminates the possibility of one or more individual discs located in the tank adaptor from failing to burst. The assembly consists of a stainless steel body which houses the burst disc. When utilizing this assembly in a manifolded system, it is necessary to modify (remove) the burst disc located in all of the R-102 tank adaptors in the system. The in-line burst disc assembly is to be mounted as close to the tank outlet as possible. After system discharge, the assembly must be disassembled and a new burst disc installed.

Part No.	Description
416970	In-Line Burst Disc Assembly
417911	Burst Disc (Pack of 10)

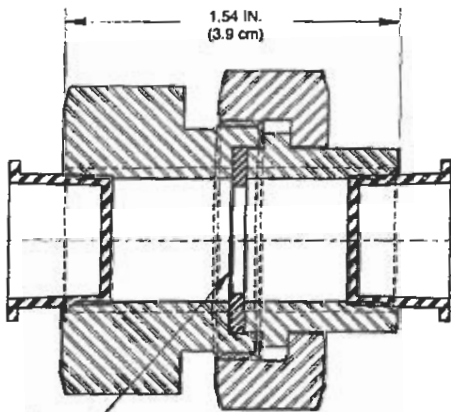

RED SIDE OF BURST DISC TO BE TOWARDS ADAPTOR, PART NO. 417707

FIGURE 35
000303

1/4 IN. CHECK VALVE

The 1/4 in. check valve, Part No. 25627, blocks the flow of actuation gas from the actuator that was actuated to the actuator(s) that was not actuated. This prevents actuation gas from escaping from an open actuator which may have had the cartridge removed.

CHECK VALVE PART NO. 25627

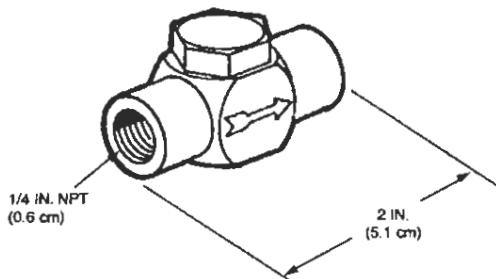

FIGURE 36
000099

NOZZLE AIMING DEVICE

The Nozzle Aiming Device, Part No. 431992, is available to properly aim each nozzle to the correct aiming point. The device clamps to the nozzle and emits a small laser light that reflects on the surface that it is aiming at. The nozzle can then be rotated to point at a predetermined aiming point and then tightened to hold that angle. The aiming device adaptor attaches to the nozzle. The shipping assembly consists of the aiming device and the adaptor.

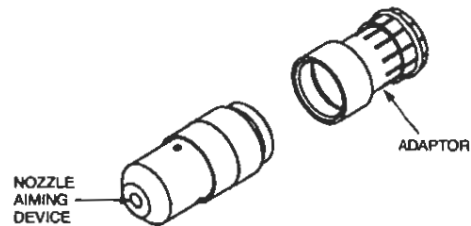

FIGURE 37
006620

STAINLESS STEEL BRAIDED ACTUATION HOSE

The Stainless Steel Actuation Hose is used to connect the actuation line compression tees between each pneumatic actuator. The hose has the same thread, 7/16-20, as the fittings. The actuation hose allows flexibility between the AUTOMAN and each regulated actuator.

Hose Part No.	Length	Couplings
31809	16 in. (41 cm)	7/16-20 x 7/16-20 Females
32335	20 in. (51 cm)	7/16-20 x 7/16-20 Females
32336	24 in. (61 cm)	7/16-20 x 7/16-20 Females
430815	42 in. (107 cm)	7/16-20 Female x 1/4 in. NPT

Fitting

Part No.	Description
31810	Male Elbow (7/16-20 x 1/4 in. NPT)
31811	Male Tee (7/16-20 x 7/16-20 x 1/4 in. NPT)
415371	Tee (7/16-20 x 1/8 in. Male NPT x 1/8 in. Female NPT)
32338	Male Straight Connector (7/16-20 x 1/4 in. NPT)
25627	1/4 in. Check Valve



FIGURE 38
000433

AGENT DISTRIBUTION HOSE AND RESTRAINING CABLE KIT

The Agent Distribution Hose and Restraining Cable Kit, Part No. 435982, consists of a 5 ft (1.5 m) long Agent Distribution Hose, a 3 ft (0.9 m) long Restraining Cable, and a Restraining Cable Hardware Package. The Agent Distribution Hose can be utilized with castered cooking appliances with castered supports found in commercial kitchens. The hose allows for movement of the appliance for cleaning without having to disconnect any fire suppression system discharge piping.

Note: The Agent Distribution Hose is authorized for use with only UL Listed ANSUL Wet Chemical Restaurant Fire Suppression Systems.

SYSTEM DESIGN

The ANSUL R-102 Restaurant Fire Suppression System may be used on a number of different types of restaurant cooking appliances and hood and duct configurations. The design information listed in this section deals with the limitations and parameters of this pre-engineered system. Those individuals responsible for the design of the R-102 system must be trained and hold a current ANSUL certificate in an R-102 training program.

The R-102 and the PIRANHA systems use compatible agents and components, therefore, they may be used together for cooking appliance, hood, and duct protection. The primary ANSUL AUTOMAN Release can be either an R-102 or a PIRANHA ANSUL AUTOMAN Release and can actuate up to two additional R-102 or PIRANHA Regulated Actuators. In systems utilizing a 101 remote release, any combination of the maximum number of regulated actuators can be used.

- Both systems must actuate simultaneously.
- Each system must be designed and installed per its appropriate manual.
- Adjacent appliances requiring protection must be protected with the same type of system, either R-102 or PIRANHA, unless the center-to-center spacing between the adjacent R-102 and PIRANHA nozzles is no less than 36 in. (91.4 cm).
- When appliances are protected with R-102 nozzles, the hood and connecting duct above those appliances cannot be protected with PIRANHA nozzles.
- Mixing systems in a common plenum is not allowed.

One of the key elements for restaurant fire protection is a correct system design. This section is divided into ten sub-sections: Nozzle Placement Requirements, Tank Quantity Requirements, Actuation and Expellant Gas Line Requirements, Distribution Piping Requirements, Detection System Requirements, Manual Pull Station Requirements, Mechanical Gas Valve Requirements, Electrical Gas Valve Requirements, Electrical Switch Requirements, and Pressure Switch Requirements. Each of these sections must be completed before attempting any installation. System design sketches should be made of all aspects of design for reference during installation.

NOZZLE PLACEMENT REQUIREMENTS

This section gives guidelines for nozzle type, positioning, and quantity for duct, plenum, and individual appliance protection. This section must be completed before determining tank quantity and piping requirements.

Duct Protection – Single Nozzle

All duct protection is UL listed without limitation of maximum duct length (unlimited length). This includes all varieties of ductworks both horizontal and vertical including ducts that run at angles to the horizontal and ducts with directional bends.

The R-102 system uses different duct nozzles depending on the size of duct being protected.

GENERAL INFORMATION

1. Nozzles must be located 2-8 in. (5-20 cm) into the center of the duct opening, discharging up. See Figure 1.

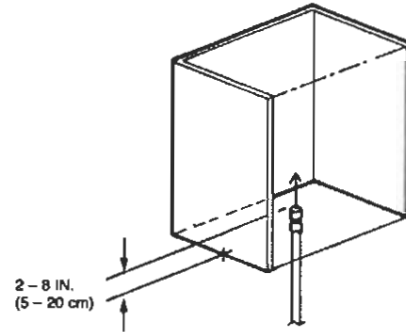

FIGURE 1
000173

2. In installations where a UL listed damper assembly is employed, the duct nozzle can be installed beyond the 8 in. (20 cm) maximum, to a point just beyond the damper assembly that will not interfere with the damper. Exceeding the maximum of 8 in. (20 cm) in this way will not void the UL listing of the system.
3. Previously listed 3 flow number and 5 flow number duct protection detailed in earlier published manual, Part No. 418087-06, can also still be utilized.

DUCT SIZES UP TO 50 IN. (127 cm)
 PERIMETER/ 16 IN. (41 cm) DIAMETER

- One 1W nozzle (Part No. 419336) = one flow number
- 50 in. (127 cm) perimeter maximum
- 16 in. (41 cm) diameter maximum

DUCT SIZES UP TO 100 IN. (254 cm)
 PERIMETER/ 32 IN. (81.3 cm) DIAMETER

- One 2W Nozzle (Part No. 419337) = two flow numbers
- 100 in. (254 cm) perimeter maximum
- 32 in. (81.3 cm) diameter maximum

The chart below shows the maximum protection available from each duct nozzle.

Description	Part No.	3.0 Gallon System	1.5 Gallon System
2W Nozzle	419337	Maximum 100 in. (254 cm) Perimeter	Maximum 100 in. (254 cm) Perimeter
1W Nozzle	419336	Maximum 50 in. (127 cm) Perimeter	Maximum 50 in. (127 cm) Perimeter

SECTION IV – SYSTEM DESIGN

Duct Protection – Multiple Nozzle

DUCT SIZES UP TO 135 IN. (343 cm) PERIMETER – 3 FLOW OPTION

- ▶ • One 1W Nozzle (Part No. 419336) and one 2W Nozzle (Part No. 419337) = three flow numbers
- 135 in. (343 cm) perimeter maximum
- No round duct option available
- Follow design table in Figure 2 to determine maximum module size for each nozzle

Side A Maximum in. (cm)	Side B Maximum in. (cm)	1W Module Side B Maximum in. (cm)		2W Module Side B Maximum in. (cm)	
		in.	(cm)	in.	(cm)
4 (10)	60.0 (152)	23.0 (58)		37.0 (94)	
5 (13)	60.0 (152)	23.0 (58)		37.0 (94)	
6 (15)	59.5 (151)	22.5 (57)		37.0 (94)	
7 (18)	59.0 (150)	22.0 (56)		37.0 (94)	
8 (20)	58.5 (149)	22.0 (56)		36.5 (93)	
9 (23)	58.0 (147)	21.5 (55)		36.5 (93)	
10 (25)	57.0 (145)	21.0 (53)		36.0 (91)	
11 (28)	56.0 (142)	20.5 (52)		35.5 (90)	
12 (31)	55.5 (141)	20.0 (51)		35.5 (90)	
13 (33)	54.5 (138)	19.5 (50)		35.0 (89)	
14 (36)	53.5 (136)	18.5 (47)		35.0 (89)	
15 (38)	52.0 (132)	18.0 (46)		34.0 (86)	
16 (41)	51.0 (130)	17.0 (43)		34.0 (86)	
17 (43)	49.5 (126)	16.0 (41)		33.5 (85)	
18 (46)	47.5 (121)	14.5 (37)		33.0 (84)	
19 (48)	46.0 (117)	13.5 (34)		32.5 (83)	
20 (51)	43.5 (111)	12.0 (31)		31.7 (81)	
21 (53)	41.0 (104)	10.0 (25)		31.0 (79)	
22 (56)	38.0 (97)	7.5 (19)		30.5 (78)	
23 (58)	33.5 (85)	4.0 (10)		29.5 (75)	

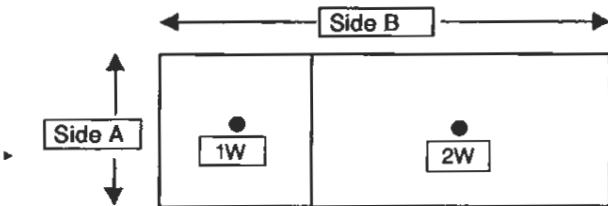

FIGURE 2
006521

Example: Protection is required for a duct that has an "A" dimension of 8.0 in. (20 cm) wide and a "B" dimension of 55 in. (140 cm) long.

Referring to the table in Figure 2, if the "A" dimension is 8.0 in. (20 cm), the "B" dimension must not exceed 58.5 in. (149 cm). In this example, the "B" dimension is 55 in. (140 cm), therefore, this duct can be protected with a three flow application.

- ▶ Read over from the 8.0 in. (20 cm) line on the table to the 1W Module column. At that point, the chart shows that the "B" module length for the 1W nozzle can be 22.0 in. (56 cm). Center the 1W nozzle in that module. The 2W module can now be centered within the remaining module.

SECTION IV – SYSTEM DESIGN

UL EX3470 ULC EX3470 Page 4-4
REV. 7 7-1-09

Transition Protection

Transitions are protected at a point in the transition where the perimeter or the diameter is equal to or less than the maximum size duct that can be protected. The nozzle(s) must be located in the center of the area at that point, or center of the module protected when more than one duct nozzle is required. **Note: Nozzles to protect ducts with a transition that is more than 4 ft (1.2 m) in height, will be required to be positioned in the opening of the transition from the hood 2 to 8 in. (5.1 to 20.3 cm) into the opening using standard duct nozzle design parameters. See Figure 4.**

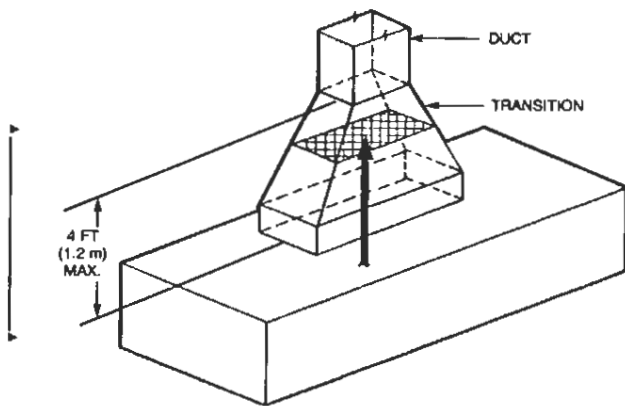

FIGURE 4
000174

Electrostatic Precipitator Protection

Some restaurant ventilating ducts have an electrostatic precipitator installed at or near the base. These precipitators are generally small and are used to aid in the cleaning of exhaust air.

Ducts with precipitators located at or near the base can be protected using duct nozzle(s) above the precipitator and 1/2N nozzle(s) (Part No. 419334) for the precipitator. One 1/2N nozzle must be used for each cell being protected. This nozzle tip is stamped with 1/2N, indicating that it is a 1/2-flow nozzle and must be counted as 1/2 flow number.

When protecting ducts equipped with precipitators, the duct nozzle(s) must be installed above the precipitator and aimed to discharge downstream. If the area above the precipitator is a duct, the nozzle(s) must be positioned according to duct protection guidelines. If the area above the precipitator is a transition, the transition guidelines must be followed.

The 1/2N nozzle (Part No. 419334) must be centered 10 to 26 in. (25 to 66 cm) below the precipitator and aimed to discharge at the center of each precipitator cell. However, if it is physically impossible to mount the nozzle at 10 to 26 in. (25 to 66 cm) due to precipitator placement, the nozzle may be mounted closer than 10 in. (25 cm). See Figure 5.

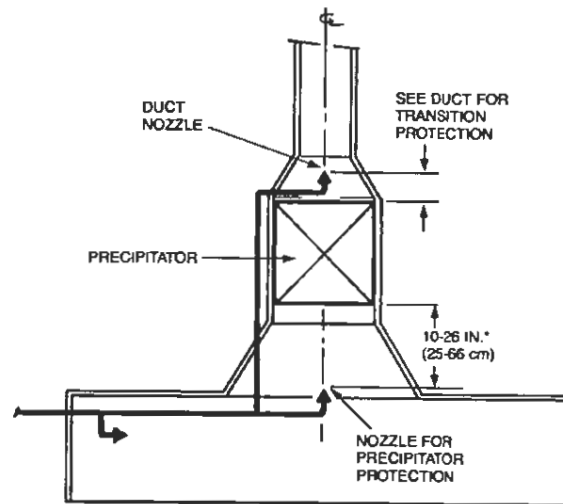

* IF PHYSICALLY IMPOSSIBLE AT 10 TO 26 IN. (25 TO 66 cm), NOZZLE MAY BE MOUNTED CLOSER THAN 10 IN. (25 cm).

FIGURE 5
000196

- ▶ **Note:** For protection of Pollution Control Units (PCUs) or air scrubbers with or without ESPs, contact Ansl Technical Services for non-UL listed recommended application.

Plenum Protection

The R-102 system uses the 1W Nozzle (Part No. 419336) or the 1N Nozzle (Part No. 419335) for plenum protection. The 1W nozzle tip is stamped with 1W and the 1N nozzle tip is stamped with 1N, indicating they are one-flow nozzles and must be counted as one flow number each. When protecting a plenum chamber, the entire chamber must be protected regardless of filter length.

VERTICAL PROTECTION – GENERAL

- ▶ 1W NOZZLE – PART NO. 419336 – SINGLE AND “V” BANK PROTECTION

One 1W nozzle will protect 4 linear feet (1.2 m) of plenum. The maximum distance from the end of the hood to the first and last nozzle must be no more than 2 ft (0.6 m). After the first nozzle, any additional nozzles must be positioned at a maximum of 4 ft (1.2 m) apart down the entire length of the plenum. The plenum width must not exceed 4 ft (1.2 m). (The 1W nozzle can be used on single or V-bank filter arrangements.) See Figure 6.

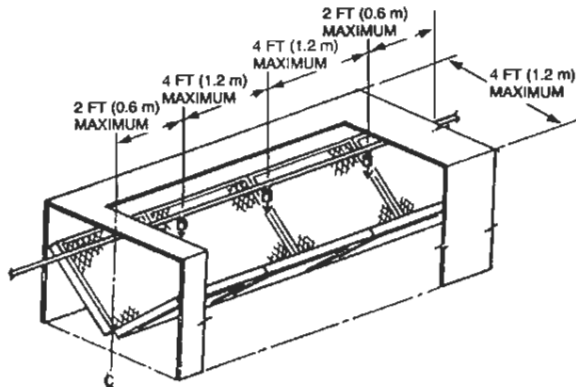

FIGURE 6
000197

When protecting plenums with the 1W nozzle, two options of coverage are available:

- ▶ **Option 1:** The 1W nozzle must be on the center line of the single or “V” bank filter and positioned within 1-20 in. (2.5-51 cm) above the top edge of the filter. See Figure 7.

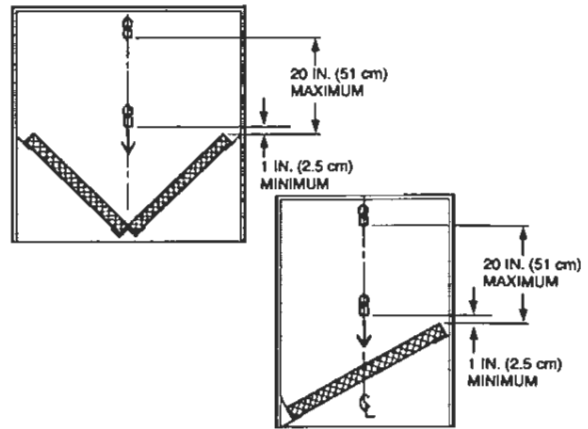

FIGURE 7
000199

- ▶ **Option 2:** The 1W nozzle must be placed perpendicular, 8-12 in. (20-30 cm) from the face of the filter and angled to the center of the filter. The nozzle tip must be within 2 in. (5 cm) from the perpendicular center line of the filter. See Figure 8.

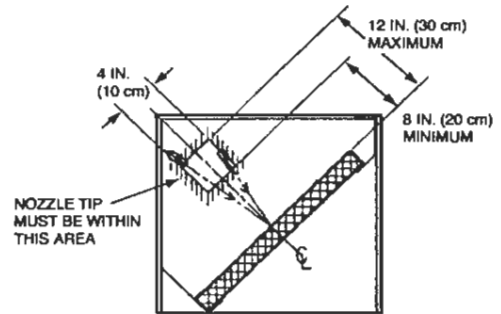

FIGURE 8
000200

HORIZONTAL PROTECTION – OPTION 1

1N NOZZLE – PART NO. 419335 – SINGLE BANK PROTECTION

One 1N nozzle will protect 10 linear feet (3.1 m) of single filter bank plenum. The nozzle(s) must be mounted in the plenum, 2 to 4 in. (5 to 10 cm) from the face of the filter, centered between the filter height dimension, and aimed down the length. The nozzle must be positioned 0-6 in. (0-15 cm) from the end of the hood to the tip of the nozzle. See Figure 9.

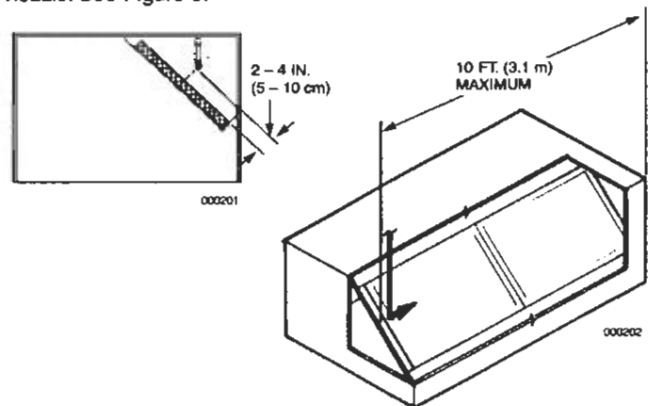

FIGURE 9

Plenum Protection (Continued)

HORIZONTAL PROTECTION – OPTION 2

1W NOZZLE – PART NO. 419336 – “V” BANK PROTECTION

One 1W nozzle will protect 6 linear feet (1.8 m) of “V” bank plenum. The nozzle must be mounted horizontally, positioned 1/3 the filter height down from the top of the filter. Nozzles can be located at 6 ft (1.8 m) spacings on longer plenums. The nozzle must be positioned 0-6 in. (0-15 cm) from the end of the hood to the tip of the nozzle. See Figure 10.

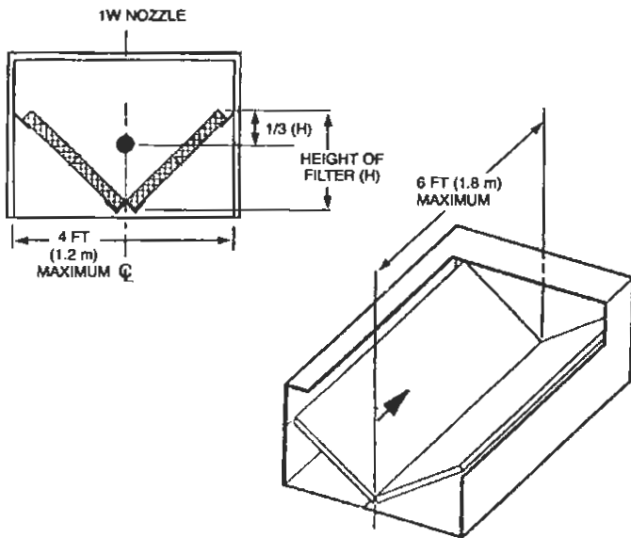

FIGURE 10
006524

▶ TWO (2) 1N NOZZLES – PART NO. 419335 – “V” BANK PROTECTION

Two 1N nozzles will protect 10 linear feet (3.1 m) by 4 ft (1.2 m) wide of “V” bank plenum. The nozzles must be mounted in the plenum, 2 to 4 in. (5 to 10 cm) from the face of the filter, centered between the filter height dimension, and aimed down the length. The nozzle must be positioned 0-6 in. (0-15 cm) from the end of the hood to the tip of the nozzle. See Figure 11.

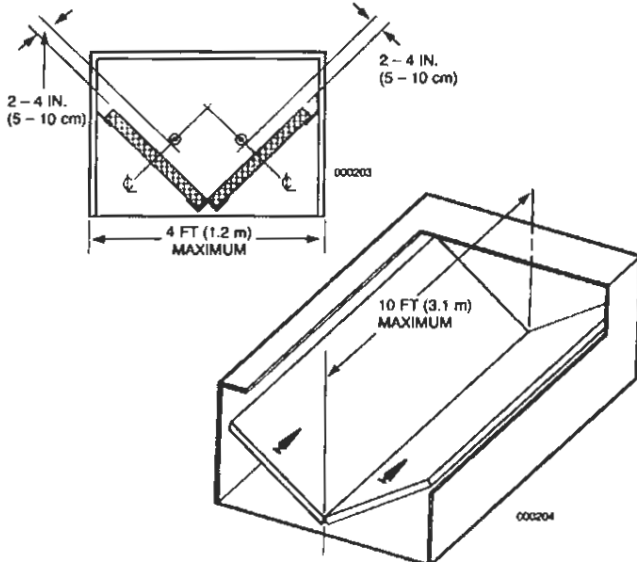

FIGURE 11

For a plenum, either single or “V” bank, with a linear extension longer than 10 ft (3.1 m), each bank may be protected using one 1N nozzle every 10 ft (3.1 m) or less depending on the overall length of the plenum. See Figure 12. The nozzles may point in the opposite directions as long as the entire plenum area is protected, and the 10 ft (3.1 m) limitation is not exceeded. See Figure 13. The nozzle positioning shown in Figure 14 is not an acceptable method of protection because the plenum area directly under the tee is not within the discharge pattern of either nozzle.

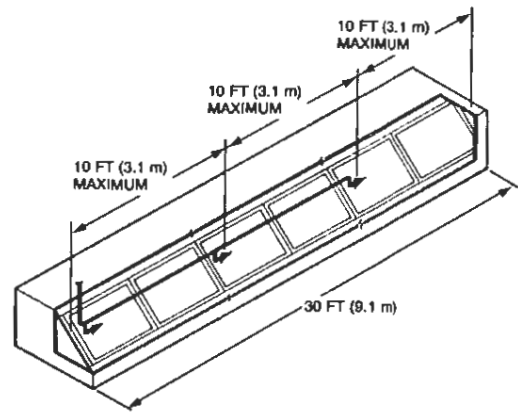

FIGURE 12
000206

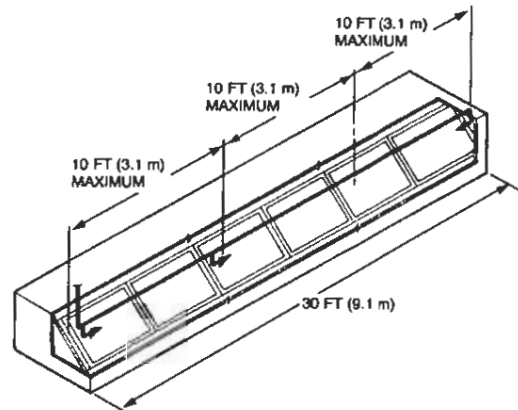

FIGURE 13
000207

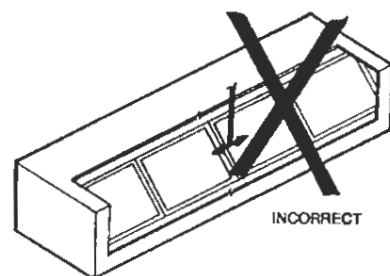

FIGURE 14
000208

Appliance Protection

The following pages detail types of appliance protection. Each design requires several factors: correct nozzle choice, correct nozzle height above hazard, correct nozzle location and correct aiming point.

Fryer – Single Nozzle Protection

1. Design requirements for fryers are broken down into two types.
 - A. FRYERS WITHOUT DRIPBOARDS
If the fryer does not include a dripboard, measure the internal depth (horizontal dimension from front to back) and length of the frypot.
 - B. FRYERS WITH DRIPBOARDS
If the fryer includes any dripboard areas, measure both the internal depth (horizontal dimension from front to back) and length of the frypot portion, and then measure the internal depth and length of the overall hazard area including any dripboard areas.
2. Using Table, "Maximum Cooking Area Dimension – Single Nozzle Fryer Protection," determine which nozzle is needed to protect the fryer based on the maximum dimensions listed.
 - A. If the fryer does not include a dripboard, use the maximum dimensions listed in the first column of the table to select the correct nozzle.
 - B. If the fryer includes any dripboard areas, use both the maximum frypot dimensions in the first column of the table, **and** the maximum overall dimensions in the second column of the table to select the correct nozzle. None of the maximum dimensions in either column may be exceeded.
3. If either the maximum frypot or the overall sizes are exceeded, an additional nozzle(s) will be required. Refer to the multiple nozzle requirements.

Example: A fryer with a dripboard. The inside of the frypot without the dripboard measures 18 in. in depth x 18 in. in length (46 cm x 46 cm) and the inside of the overall area including the dripboard measures 18 in. in depth x 24 in. in length (46 cm x 61 cm). From the Table "Maximum Cooking Area Dimension – Single Nozzle Fryer Protection," either the 3N or the 290 nozzle should be selected to protect the fryer, depending on the maximum nozzle height above the fryer and the positioning requirements allowed. Refer to appropriate Figures.

Fryer – Single Nozzle Protection (Continued)

Maximum Area Dimensions – Single Nozzle Fryer Protection

Max. Size Frypot Only	Max. Size Overall With Dripboard	Type of Nozzle	Nozzle Height Above Top of Fryer	Nozzle Location
Full or Split Vat 14 in. x 15 in. (36 cm x 38 cm)	Full or Split Vat 14 in. x 21 in. (36 cm x 53 cm)	230	27 in. to 47 in. (69 cm to 119 cm)	See Figure 15 and 16
Full or Split Vat 14 in. x 15 in. (36 cm x 38 cm)	Full or Split Vat 14 in. x 21 in. (36 cm x 53 cm)	245	20 in. to 27 in. (51 cm to 69 cm)	See Figure 15 and 16
Full or Split Vat 14 in. x 15 in. (36 cm x 38 cm)	Full or Split Vat 14 in. x 21 in. (36 cm x 53 cm)	290	13 in. to 16 in. (33 cm to 41 cm)	See Figure 17
Full or Split Vat 14 1/2 in. x 14 in. (37 cm x 38 cm)	Full or Split Vat 14 1/2 in. x 26 1/2 in. (37 cm x 67 cm)	290	16 in. to 27 in. (41 cm to 69 cm)	See Figure 17

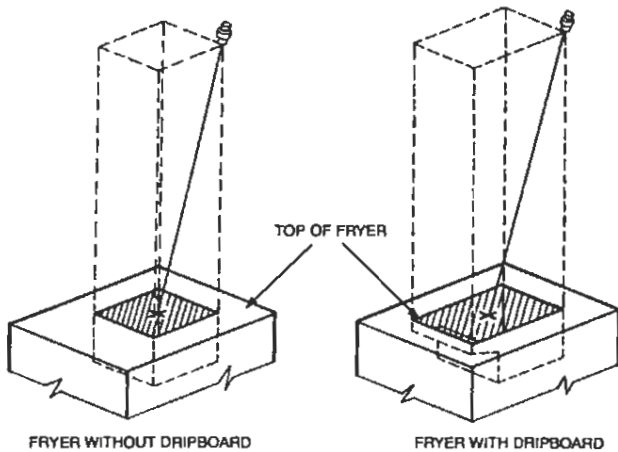

NOZZLE TIP POSITIONED ANYWHERE ALONG OR WITHIN PERIMETER OF COOKING SURFACE AND AIMED TO THE CENTER OF THE COOKING AREA.

FIGURE 15
002280

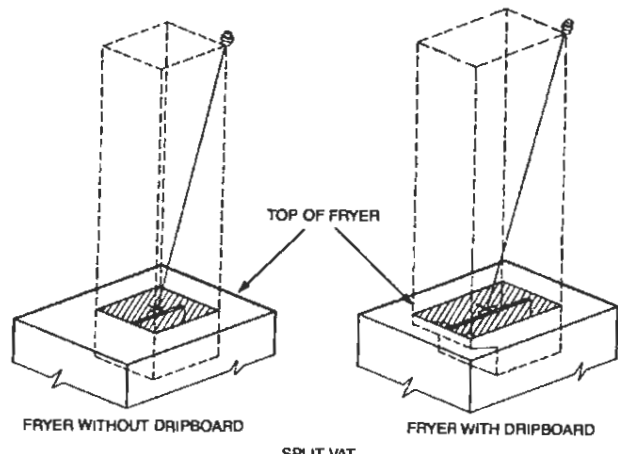

NOZZLE TIP POSITIONED ANYWHERE ALONG OR WITHIN PERIMETER OF COOKING SURFACE AND AIMED TO THE CENTER OF THE COOKING AREA.

FIGURE 16
002283

Fryer – Single Nozzle Protection (Continued)

Maximum Area Dimensions – Single Nozzle Fryer Protection (Continued)

Max. Size Frypot Only	Max. Size Overall With Dripboard	Type of Nozzle	Nozzle Height Above Top of Fryer	Nozzle Location
19.5 in. x 19 in. (50 cm x 48 cm)	19.5 in. x 25 3/8 in. (50 cm x 65 cm)	290	13 in. to 16 in. (33 to 41 cm)	See Figure 17
19.5 in. x 19 in. (50 cm x 48 cm)	19.5 in. x 25 3/8 in. (50 cm x 65 cm)	3N	See Figure 18	See Figure 18
▶ 18 in. x 18 in. ▶ (46 cm x 46 cm)	18 in. x 27 3/4 in. (46 cm x 70.5 cm)	3N	25 in. to 35 in. (64 cm to 89 cm)	See Figure 19

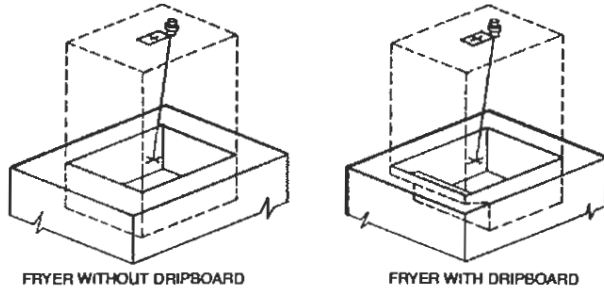

290 NOZZLE TIP POSITIONED OVER THE MIDPOINT OF THE HAZARD AREA ± 3 IN. (7.8 cm) FROM THE MIDPOINT ALONG THE LONGEST SIDE OF THE HAZARD AND ± 1 IN. (2.5 cm) FROM THE MIDPOINT ALONG THE SHORTEST SIDE OF THE HAZARD AND AIMED AT THE MIDPOINT OF THE COOKING AREA.

FIGURE 17
002286

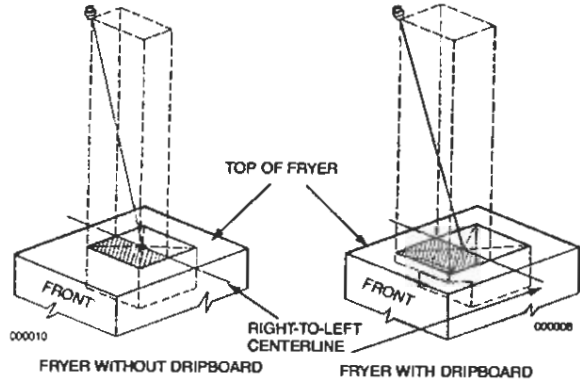

NOTE: 3N NOZZLE TIP MUST BE LOCATED WITHIN THE PERIMETER OF THE SURFACE AREA WITHIN THE FRONT HALF OF THE FRY POT AND AIMED AT THE CENTER.

FIGURE 19

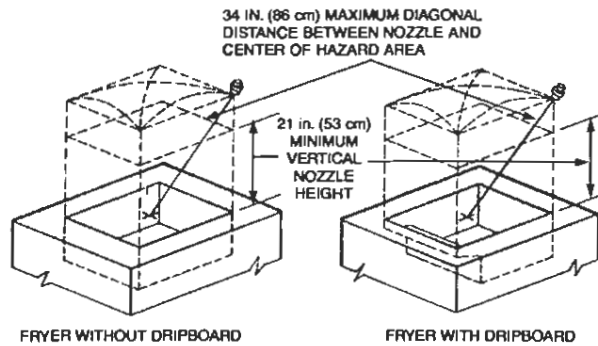

3N NOZZLE TIP POSITIONED ANYWHERE ALONG OR WITHIN PERIMETER OF COOKING SURFACE AND AIMED TO THE CENTER OF THE COOKING AREA.

FIGURE 18
002287

Fryer – Multiple Nozzle Protection

Design Requirements:

Fryers exceeding the coverage of a single nozzle can be divided into modules. Each module must not exceed the maximum area allowed for a single nozzle. However, when utilizing multiple nozzle protection, the longest side allowed for a fryer with dripboard can be used, regardless of whether the fryer has a dripboard or not.

- ▶ The maximum size fryer that can be modularized is 864 in.² (5574 cm²) or in terms of ft, 6 ft² (0.6 m²).
- 1. Design requirements for multiple nozzle fryers are broken down into two types:
 - A. FRYERS WITHOUT DRIPBOARD(S)

If the fryer does not include a dripboard, measure the internal depth (horizontal dimension from front to back) and length of the frypot. Then, multiply the depth and length to obtain the area of the frypot in square inches.
 - B. FRYERS WITH DRIPBOARD(S)

If the fryer includes any dripboard areas, measure both the internal depth and length of the frypot portion, and then measure the internal depth and length of the overall hazard area including any dripboard areas.

Determine the area of both the frypot and the area of the overall vat by multiplying corresponding depth and length dimensions.
- 2. Divide the frypot or overall vat into modules, each of which can be protected by a single nozzle, based on the maximum dimension and area coverage of the nozzle as specified in Table, "Maximum Cooking Area Dimension – Multiple Nozzle Protection."
 - A. If the module considered does not include any portion of the dripboard, use only the maximum frypot area and maximum dimension listed in the first column of the table to select the correct nozzle.
 - B. If the module considered includes any dripboard areas, use both the maximum frypot area and dimension listed in the first column of the table, and the maximum overall area and dimensions listed in the second column of the table to select the correct nozzle.
- 3. None of the maximum dimensions in either column may be exceeded. If either the maximum frypot or the overall sizes are exceeded, the area divided into modules will need to be re-defined with the possibility of an additional nozzle.

Example: A fryer with a dripboard. The inside vat without the dripboard measures 18 in. in depth x 30 in. in length (46 cm. x 76 cm) and the inside of the overall vat including the dripboard measures 24 in. in depth x 30 in. in length (61 cm x 76 cm). Because the fryer is 30 in. (76 cm) in length, it exceeds the coverage of a single nozzle.

Dividing the length in half, each module now has an overall vat dimension of 24 in. in depth x 15 in. in length (61 x 38 cm). From the Table, "Maximum Cooking Area Dimension – Multiple Nozzle Fryer Protection," either the 3N or the 290 nozzle should be selected to protect each fryer module, depending on the maximum nozzle height above the fryer and the positioning requirements allowed. Refer to appropriate Figures, 15 through 19.

See additional examples in Appendix Section.

Options For Modularizing Fryers

The following Figure 20 shows approved methods of dividing (modularizing) fryers so that each section can be properly protected.

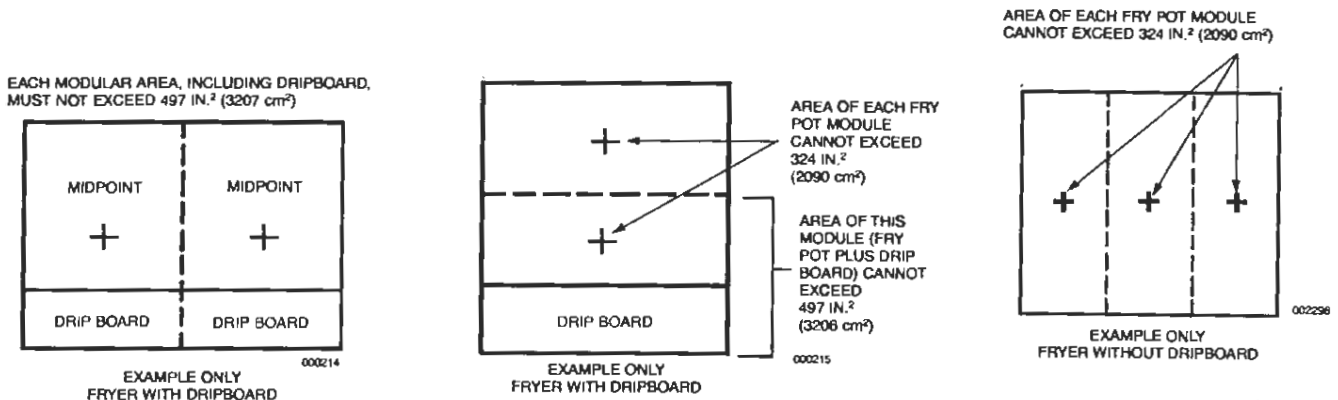
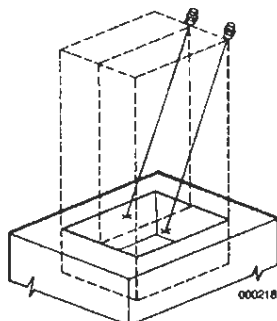

FIGURE 20

Fryer – Multiple Nozzle Protection (Continued)

Maximum Area Dimension – Multiple Nozzle Fryer Protection

Max. Size Module Frypot Only	Max. Size Module Overall With Dripboard	Type of Nozzle	Nozzle Height Above Top of Fryer	Nozzle Location
▶ Full or Split Vat 21 in. x 210 in. ² (53 cm x 0.14 m ²)	Full or Split Vat 21 in. x 294 in. ² (53 cm x 0.19 m ²)	230	27 in. to 47 in. (69 cm to 119 cm)	See Figure 21
▶ Full or Split Vat 21 in. x 210 in. ² (53 cm x 0.14 m ²)	Full or Split Vat 21 in. x 294 in. ² (53 cm x 0.19 m ²)	245	20 in. to 27 in. (51 to 69 cm)	See Figure 21
▶ Full or Split Vat 21 in. x 210 in. ² (53 cm x 0.14 m ²)	Full or Split Vat 21 in. x 294 in. ² (53 cm x 0.19 m ²)	290	13 in. to 16 in. (33 to 41 cm)	See Figure 22
25 3/8 x 370.5 in. ² (65 cm x 0.24 m ²)	25 3/8 x 495 in. ² (65 cm x 0.32 m ²)	290	13 in. to 16 in. (33 to 41 cm)	See Figure 22
▶ Full or Split Vat 26 1/2 in. x 203 in. ² (67 cm x 0.13 m ²)	Full or Split Vat 26 1/2 in. x 384 1/4 in. ² (67 cm x 0.25 m ²)	290	16 in. to 27 in. (41 to 69 cm)	See Figure 22
25 3/8 x 370.5 in. ² (65 cm x 0.24 m ²)	25 3/8 x 495 in. ² (65 cm x 0.32 m ²)	3N	See Figure 23	See Figure 23
▶ 27 3/4 x 324 in. ² (70.5 cm x 0.21 m ²)	27 3/4 x 497 in. ² (70.5 cm x 0.32 m ²)	3N	25 in. to 35 in. (64 cm to 89 cm)	See Figure 24



FRYER WITHOUT DRIPBOARD

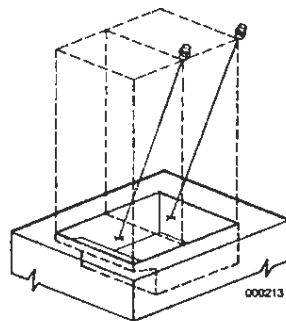

FRYER WITH DRIPBOARD

POSITION NOZZLE TIP ANYWHERE ALONG OR WITHIN THE PERIMETER OF THE MODULE IT IS PROTECTING AND AIM AT THE MIDPOINT OF THAT MODULAR AREA.

FIGURE 21

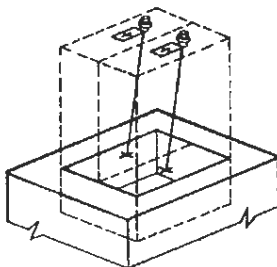

FRYER WITHOUT DRIPBOARD

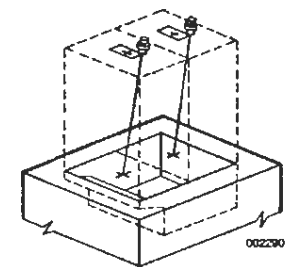

FRYER WITH DRIPBOARD

290 NOZZLE TIP POSITIONED OVER THE MIDPOINT OF THE RESPECTIVE MODULAR AREA ± 3 IN. (7.6 cm) FROM THE MIDPOINT ALONG THE LONGEST SIDE OF THE MODULE AND ± 1 IN. (2.5 cm) FROM THE MIDPOINT ALONG THE SHORTEST SIDE OF THE MODULE AND AIMED AT THE MIDPOINT OF THE MODULE.

FIGURE 22

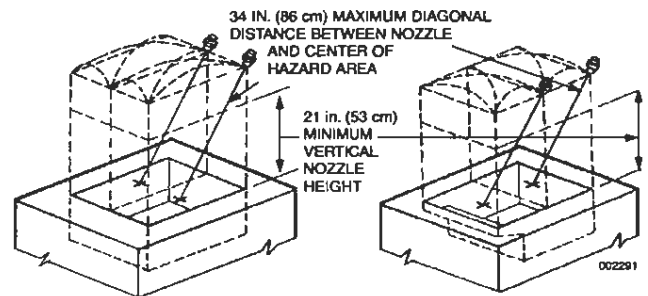

FRYER WITHOUT DRIPBOARD

FRYER WITH DRIPBOARD

3N NOZZLE TIP MUST BE POSITIONED ANYWHERE ALONG OR WITHIN THE PERIMETER OF THE MODULAR IT IS PROTECTING AND AIMED AT THE MIDPOINT OF THAT RESPECTIVE MODULE AREA.

FIGURE 23

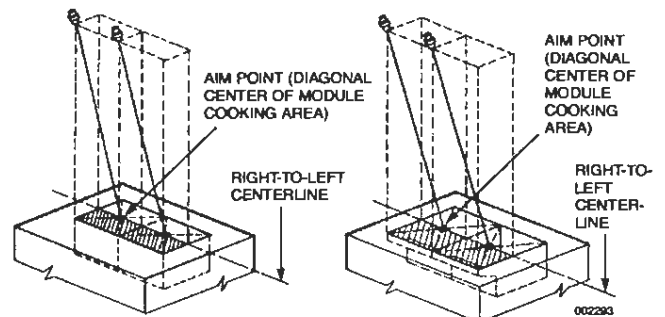

FRYER WITHOUT DRIPBOARD

FRYER WITH DRIPBOARD

THE 3N NOZZLE TIP MUST BE POSITIONED ANYWHERE ALONG OR WITHIN THE PERIMETER AND FORWARD OF THE RIGHT-TO-LEFT CENTERLINE OF THE COOKING AREA. THE AIMING POINT OF THE NOZZLE MUST BE AT THE DIAGONAL CENTER OF THE MODULAR COOKING AREA.

FIGURE 24

SECTION IV – SYSTEM DESIGN

UL EX3470 ULC EX3470 Page 4-12
REV. 6 7-1-09

Multiple Nozzle Fryer Protection – Tilt Skillet / Braising Pan

Protection for tilt skillets or braising pans is to be based upon the coverage limitations provided for deep fat fryer protection. Refer to Section IV, DESIGN, starting on Page 4-10, for maximum fryer nozzle coverages and maximum fryer nozzle height limitations.

- ▶ Although the maximum 6 ft² (0.6 m²) total surface cooking area requirement applies to fryer protection, it does not apply to tilt skillets or braising pans.

Each tilt skillet/braising pan protected module must not exceed the fryer limitations for "MAXIMUM SIZE MODULE OVERALL WITH DRIPBOARD" coverage per nozzle as described in Table on Page 4-11.

- ▶ Tilt skillets and braising pans generally utilize a hinged cover. Fryer protection nozzles are to be placed toward the front of the appliance to minimize the potential for the tilt skillet or braising pan cover to interfere with the nozzle discharge. See Figures 25 and 26.

COVER MUST NOT INTERFERE WITH NOZZLE DISCHARGE

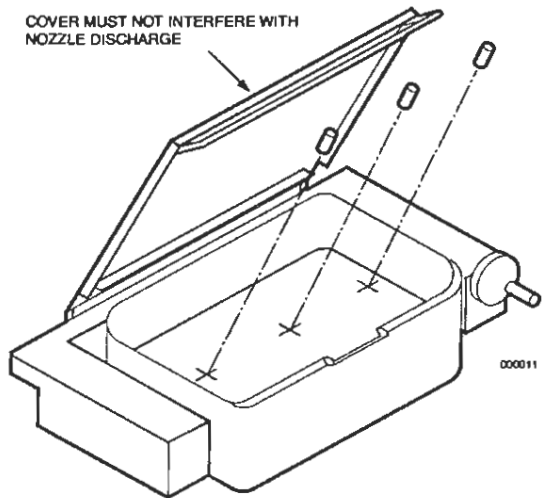

THE NOZZLE IS TO BE PLACED TOWARD THE FRONT OF THE APPLIANCE TO MINIMIZE THE POTENTIAL FOR THE SKILLET OR BRAISING PAN COVER TO INTERFERE WITH THE NOZZLE DISCHARGE.

FIGURE 25

COVER MUST NOT INTERFERE WITH EDGE OF DISCHARGE PATTERN

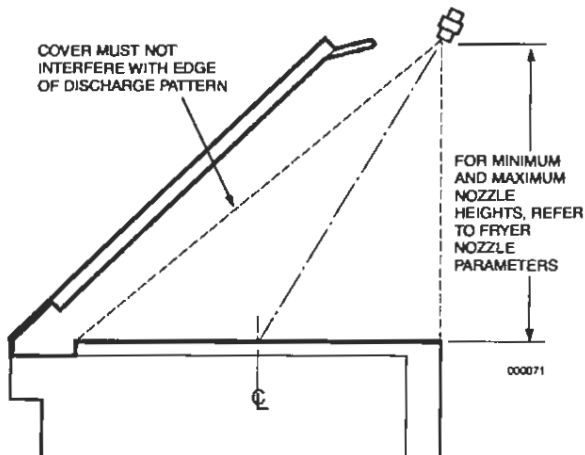

FOR MINIMUM AND MAXIMUM NOZZLE HEIGHTS, REFER TO FRYER NOZZLE PARAMETERS

FRYER NOZZLE USED FOR TILT SKILLET OR BRAISING PAN PROTECTION MUST BE POSITIONED NEAR THE FRONT EDGE OF THE PAN AND AIMED AT THE FRONT TO BACK CENTERLINE OF THE PAN. THE DISCHARGE FROM THE NOZZLE(S) MUST COMPLETELY CLEAR THE PAN COVER WITH AN UNOBSTRUCTED VIEW TO THE BACK OF THE PAN.

FIGURE 26

► **Range Protection**

The R-102 system uses five different nozzles for the protection of ranges. Two of the design options require a one-flow nozzle and three of the design options require two-flow nozzles.

NOTICE

A 13 in. (33 cm) diameter wok pan is the largest wok size that can be protected on ranges.

When protecting hot top ranges, the entire cooking surface must be protected.

► **Range Protection 1N (1-Flow) Nozzle – High Proximity Application**

► **No Obstructions**

Single and multiple burner ranges can be protected using a 1N nozzle, Part No. 419335. The nozzle tip is stamped with 1N, indicating that this is a one-flow nozzle and must be counted as one flow number.

When using this nozzle for range protection, the maximum length of the burner grates being protected with a single nozzle must not exceed 32 in. (81 cm) and the maximum area of the burner grates must not exceed 384 in.² (2477 cm²) per nozzle.

When protecting a range, the 1N nozzle must be located a maximum of 10 in. (25.4 cm) from each burner grate centerline and must be aimed at the center of the cooking surface. See Figures 27 and 28.

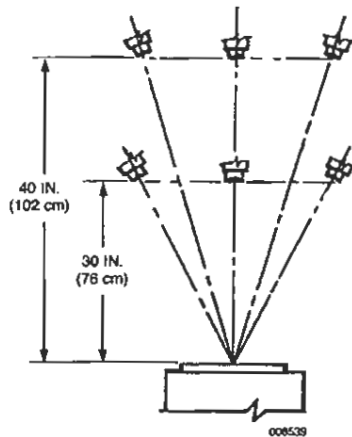

FIGURE 27

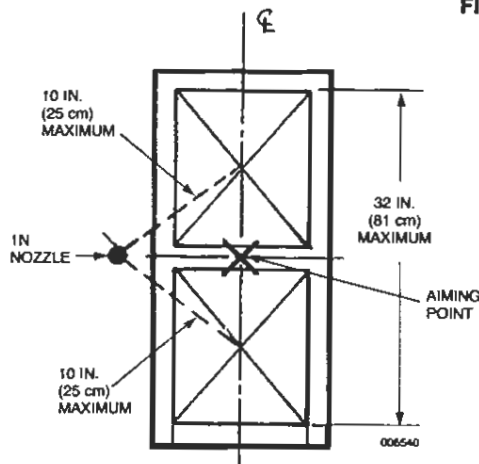

FIGURE 28

► Range Protection 245 (2-Flow) Nozzle – High Proximity Application

No Obstructions

► 40 in. to 50 in. (102 cm to 127 cm) above the cooking surface.

This high proximity application uses the 245 nozzle, Part No. 419340.

The nozzle tip is stamped with 245 indicating this is a two-flow nozzle and must be counted as two flow numbers.

► One 245 nozzle will protect a maximum cooking area of 672 in.² (4335 cm²) with a maximum longest dimension of 28 in. (71 cm).

When using this nozzle for range protection, the nozzle must be pointed vertically down and positioned as shown in Figures 29 and 30.

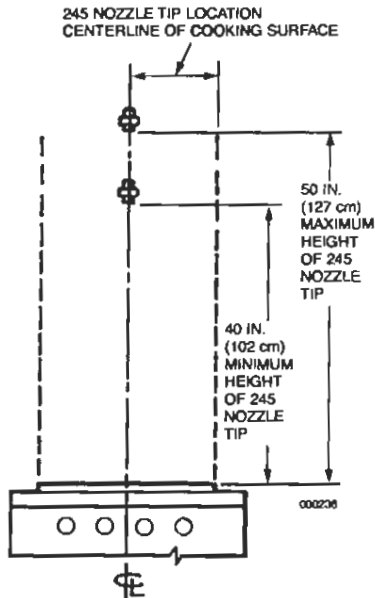

FIGURE 29

NOTICE

Four burner grates shown in Figure 30. For single or double burner grates, locate nozzle at center of cooking surface or 11 3/8 in. (29 cm) maximum from nozzle centerline to center of any burner grate.

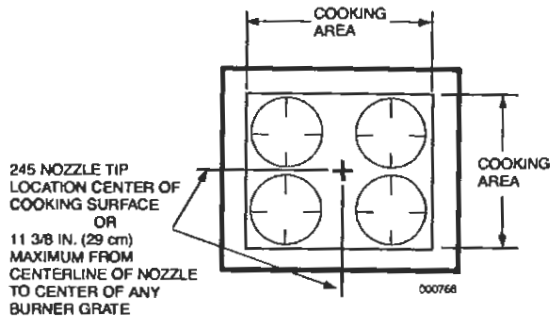
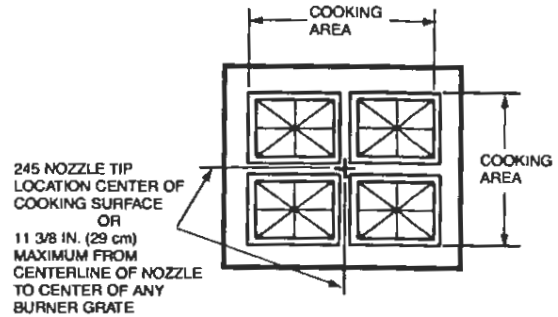

FIGURE 30

▶ **Range Protection 260 (2-Flow) Nozzle – Medium Proximity Application**

No Obstructions

- ▶ 30 in. to 40 in. (76 cm to 102 cm) above the cooking surface.

The medium proximity application uses the 260 nozzle, Part No. 419341.

The nozzle tip is stamped with 260 indicating this is a two-flow nozzle and must be counted as two flow numbers.

- ▶ One 260 nozzle will protect a cooking area of 768 in.² (4955 cm²) with a maximum dimension of 32 in. (81 cm).

When using this nozzle for range protection, the nozzle must be pointed vertically down and positioned as shown in Figures 31 and 32.

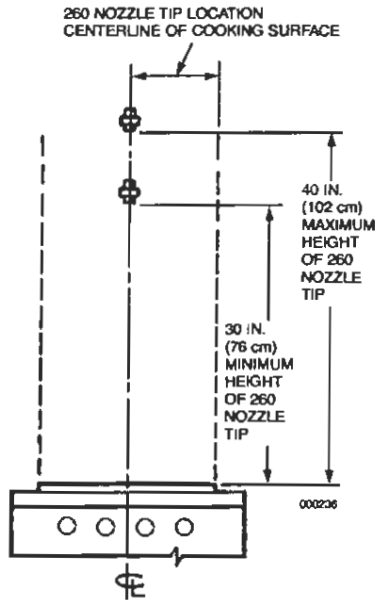

FIGURE 31

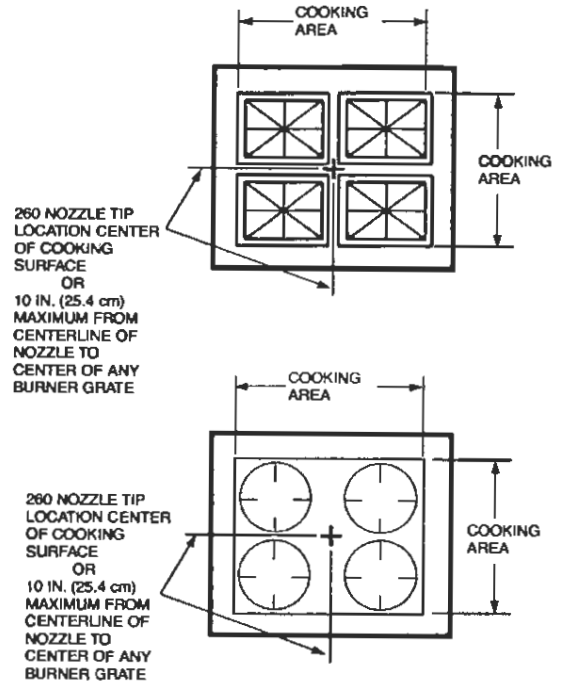

FIGURE 32
000766

NOTICE

Four burner grates shown in Figure 32. For single or double burner grates, locate nozzle at center of cooking surface.

Range Protection 1N (1-Flow) Nozzle – Low Proximity Application

15 in. to 20 in. (38.1 cm to 50.8 cm) above the cooking surface.
 The low proximity 1-flow nozzle application for the protection of ranges requires the 1N nozzle, Part No. 419335.
 The nozzle tip is stamped with 1N indicating that it is a one-flow nozzle and must be counted as one (1) flow number.
 When using the 1N nozzle for low proximity range protection with or without obstruction, the maximum length of the burner grates being protected must not be exceeded 24 in. (61.0 cm) length, aimed along a centerline to a point 20 in. (50.8 cm) from the end of the length, protecting a maximum width of 18 in. (45.7 cm).

When protecting a range, the 1N nozzle must be located a maximum of 9 in. (22.9 cm) from each burner grate centerline and must be positioned above the edge of the hazard area to be protected.

The 1N nozzle tip must be positioned at or below the obstruction, if present. The protected area begins at the point straight down from the nozzle tip. The nozzle can be placed at the side of the range aimed either left or right, or can be placed in the front or back of the range. See Figures 33 and 34 for nozzle location details.

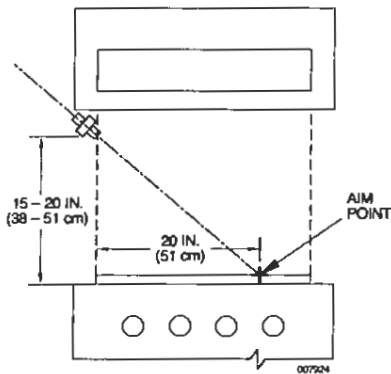

FIGURE 33

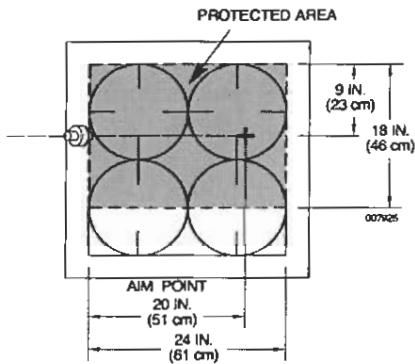

FIGURE 34

Range Protection Two (2) 290 (2-Flow) Nozzles – Low Proximity Application

15 in. to 20 in. (38 cm to 51 cm) above the cooking surface.
 The low proximity 2-flow application requires the use of two (2) 290 nozzles, Part No. 419342.
 Both nozzle tips are stamped with 290 indicating they are two flow nozzles and must be counted together for a total of four (4) flow numbers.
 Two (2) 290 nozzles will protect a cooking area of 1008 in.² (6503 cm²) with a maximum dimension of 36 in. (91 cm).

When using two of these nozzles for low proximity range protection, the nozzles must be positioned along the cooking surface perimeter to 1.5 in. (3.8 cm) inside the perimeter, and aimed at a 45° angle along the longitudinal centerline of the range. See ▶ Figures 35 and 36.

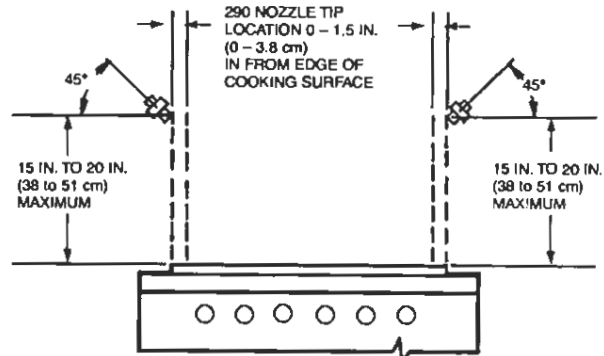

FIGURE 35
002276

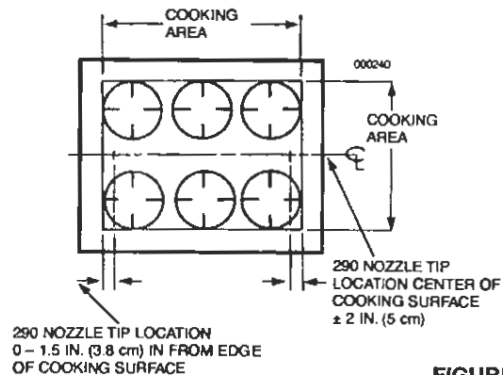
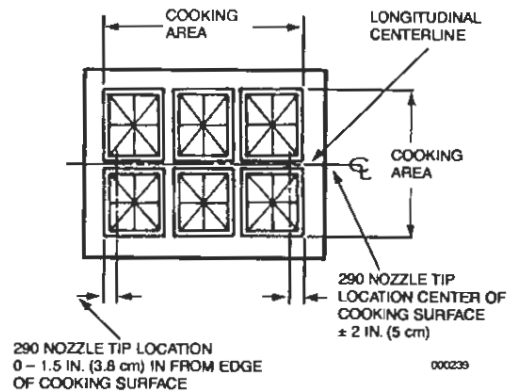

FIGURE 36

- ▶ **Range Protection (With or Without Back Shelf/Obstruction)**
- ▶ When this type of hazard is equipped with a back shelf or other similarly sized obstruction located above the range top, two protection options are available: One requires a 1F nozzle, Part No. 419333, and the other option requires a 260 nozzle, Part No. 419341.

▶ **Range Protection 1F (1-Flow) Nozzle (With or Without Back Shelf/Obstruction)**

Single and multiple burner ranges can be protected using a 1F nozzle, Part No. 419333. The nozzle tip is stamped with 1F indicating that it is a one-flow nozzle and must be counted as one flow number.

- ▶ When using the 1F nozzle for range protection with or without back shelf or other similarly sized obstruction, the maximum length of the burner grates being protected must not exceed 28 in. (71 cm) and the maximum area of the burner grates must not exceed 336 in.² (2168 cm²). See Figure 37 for nozzle location details.

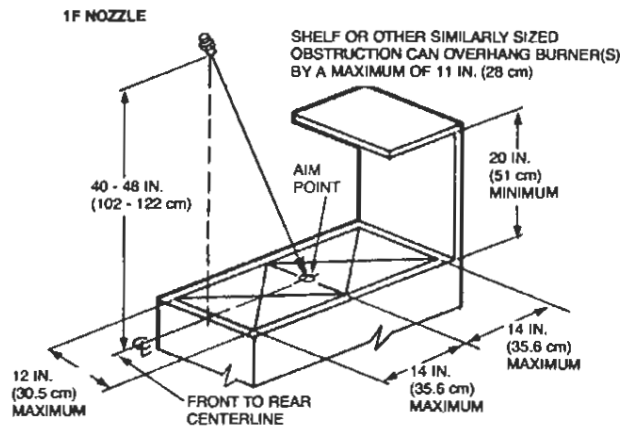

1F NOZZLE LOCATED OVER FRONT EDGE OF BURNER GRATE AND ORIENTED SO NOZZLE TIP FLATS ARE PARALLEL WITH BURNER GRATE FRONT TO REAR CENTERLINE AND SHALL BE AIMED AT THE CENTER OF THE COOKING SURFACE.

FIGURE 37
000236

▶ **Range Protection 260 (2-Flow) Nozzle (With or Without Back Shelf/Obstruction)**

Single and multiple burner ranges can be protected using a 260 nozzle, Part No. 419341. The nozzle tip is stamped with 260 indicating that it is a two-flow nozzle and must be counted as two flow numbers.

- ▶ When using the 260 nozzle for range protection with or without back shelf or other similarly sized obstruction, the maximum length of burner grates being protected must not exceed 32 in. (81 cm) and the maximum area of the burner grates must not exceed 384 in.² (2477 cm²). Nozzle must be located on the front edge of the burner grates and aimed at a point 10 in. (25 cm) from the back edge of the burner grates. Nozzle must be mounted 30 to 40 in. (76 to 102 cm) above the hazard surface. See Figure 38.

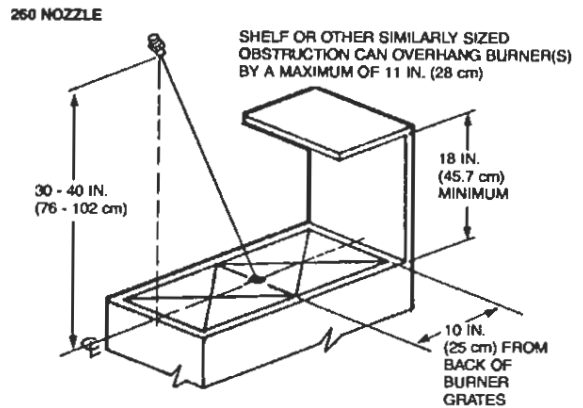

FIGURE 38
000236a

SECTION IV – SYSTEM DESIGN

Griddle Protection 1N (1-Flow) Nozzle – High Proximity Application

The R-102 system uses four different nozzles for the protection of griddles. One of the applications requires a 1-flow nozzle and three of the applications require a 2-flow nozzle.

High Proximity Application: 35 in. to 40 in. (89 to 102 cm) above the cooking surface.

This high proximity application uses the 1N nozzle, Part No. 419335.

The nozzle tip is stamped with 1N indicating this is a one-flow nozzle and must be counted as one flow number.

One 1N nozzle will protect a maximum cooking area of 1080 in.² (6968 cm²) with the maximum longest side of 36 in. (91 cm).

When using this nozzle for griddle protection, the nozzle must be positioned along the cooking surface perimeter to a maximum of 2 in. (5 cm) inside the perimeter, and aimed to the midpoint of the cooking surface. See Figure 39 and 40.

NOTICE

When using this type of griddle protection, only 5 flow numbers are allowed on a 1.5 gal (5.7 L) system and only 11 flow numbers are allowed on a 3 gal (11.4 L) system.

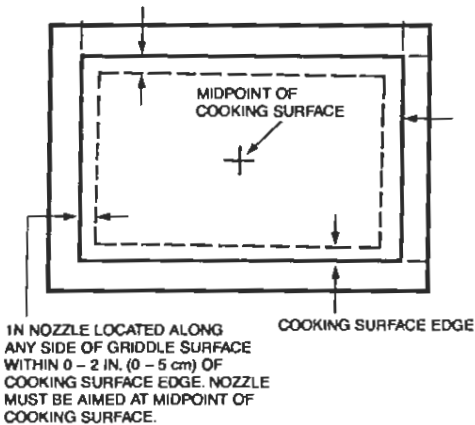

FIGURE 39
000241

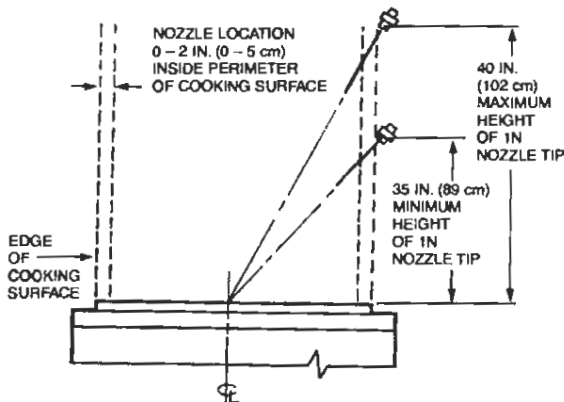

FIGURE 40
000243

Griddle Protection 290 (2-Flow) Nozzle – High Proximity Application

Option 1 – Nozzle Center Located

30 in. to 50 in. (76 cm to 127 cm) above the cooking surface.

This high proximity application uses the 290 nozzle, Part No. 419342.

The nozzle tip is stamped with 290 indicating this is a 2-flow nozzle and must be counted as two flow numbers.

One 290 nozzle will protect a maximum cooking area of 720 in.² (4645 cm²) with a maximum dimension of 30 in. (76 cm).

When using this nozzle for high proximity applications, the nozzle must be positioned within 1 in. (2.5 cm) of the center of the cooking surface and pointed vertically down. See Figure 41 and 42.

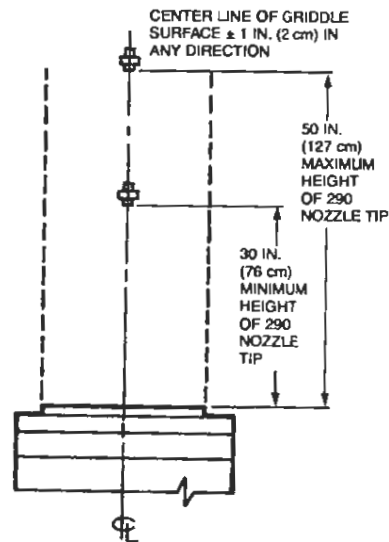

FIGURE 41
000244

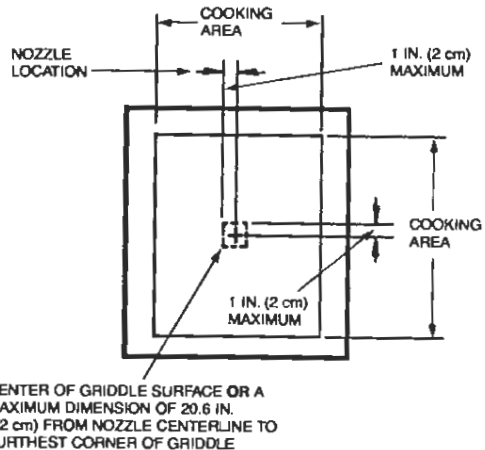

FIGURE 42
000773

► Griddle Protection 260 (2-Flow) Nozzle – High Proximity Application

► Application
 Option 2 – Nozzle Perimeter Located

► 30 in. to 50 in. (76 cm to 127 cm) above the cooking surface.

This high proximity application uses the 260 nozzle, Part No. 419341.

The nozzle tip is stamped with 260 indicating this is a two-flow nozzle and must be counted as two flow numbers.

► One 260 nozzle will protect a maximum cooking area of 1440 in.² (9290 cm²) with a maximum dimension of 48 in. (122 cm).

When using this nozzle for griddle protection, the nozzle must be positioned along the cooking surface perimeter to 2 in. (5.1 cm) inside perimeter, and aimed at the center of the cooking surface. See Figure 43 and 44.

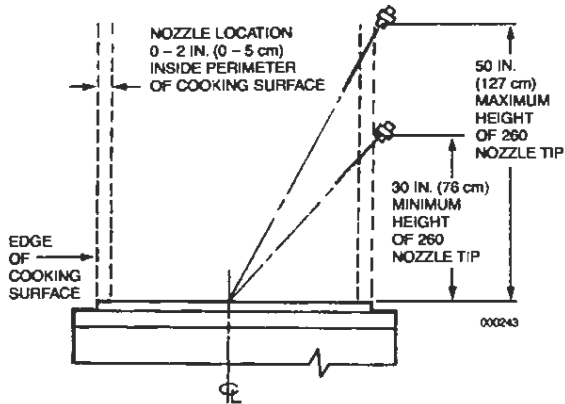

FIGURE 43
 000243

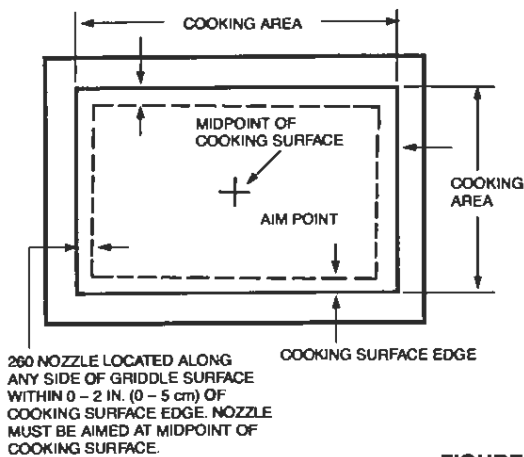

FIGURE 44
 000241

► Griddle Protection 290 (2-Flow) Nozzle – Medium Proximity Application

Option 2a – Nozzle Perimeter Located (Continued)

20 in. to 30 in. (51 cm to 76 cm) above the cooking surface.

The medium proximity application uses the 290 nozzle, Part No. 419342.

The nozzle tip is stamped with 290 indicating this is a two-flow nozzle and must be counted as two flow numbers.

One 290 nozzle will protect a maximum cooking area of 1440 in.² (9290 cm²) with a maximum dimension of 48 in. (122 cm).

When using this nozzle for griddle protection, the nozzle must be positioned along the perimeter to 2 in. (5.1 cm) inside perimeter, and aimed at the center of the cooking surface. See Figure 45 and 46.

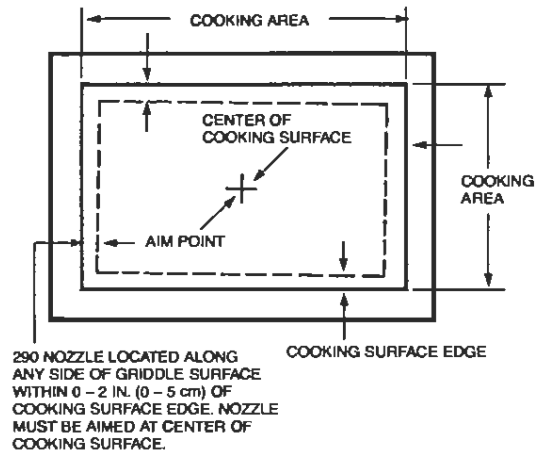

FIGURE 45
 000241

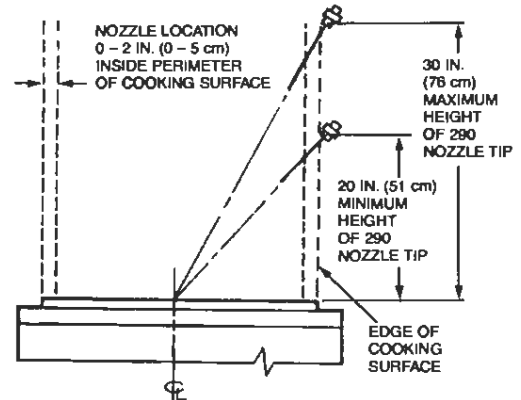

FIGURE 46
 000243

SECTION IV – SYSTEM DESIGN

Griddle Protection 2120 (2-Flow) Nozzle – Low Proximity Application

Option 2b – Nozzle Perimeter Located (Continued)

10 in. to 20 in. (25 cm to 51 cm) above the cooking surface.

The low proximity application uses the 2120 nozzle, Part No. 419343.

The nozzle tip is stamped with 2120 indicating this is a two-flow nozzle and must be counted as two flow numbers.

One 2120 nozzle will protect a maximum cooking area of 1440 in.² (9290 cm²) with a maximum dimension of 48 in. (122 cm).

When using this nozzle for griddle protection, the nozzle must be positioned along the perimeter to 2 in. (5.1 cm) inside perimeter, and aimed at the center of the cooking surface. See Figure 47 and 48.

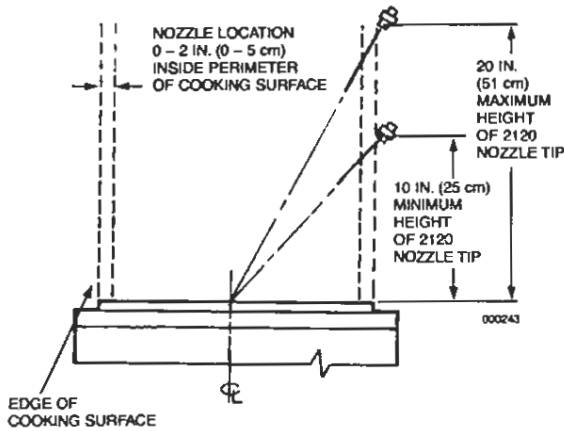

FIGURE 47
000243

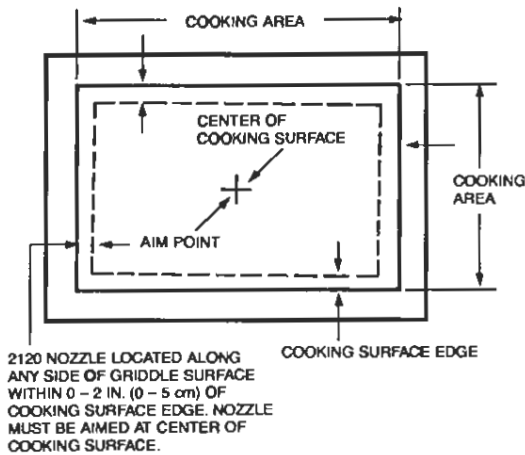

FIGURE 48
000241

Griddle Protection 2W (2-Flow) Nozzle – Low Proximity Application

Option 2c – Nozzle Perimeter Located (Continued)

10 in. to 20 in. (25 cm to 51 cm) above the cooking surface.

The low proximity application uses the 2W nozzle, Part No. 419337.

The nozzle tip is stamped with 2W indicating this is a two-flow nozzle and must be counted as two flow numbers.

One 2W nozzle will protect a maximum cooking area of 1080 in.² (6967.7 cm²) with a maximum dimension of 36 in. (91.4 cm).

When using this nozzle for griddle protection, the nozzle must be positioned along the perimeter to 9 in. (22.9 cm) inside perimeter, and aimed at the center of the cooking surface. See Figure 49 and 50.

OVERHEAD VIEW

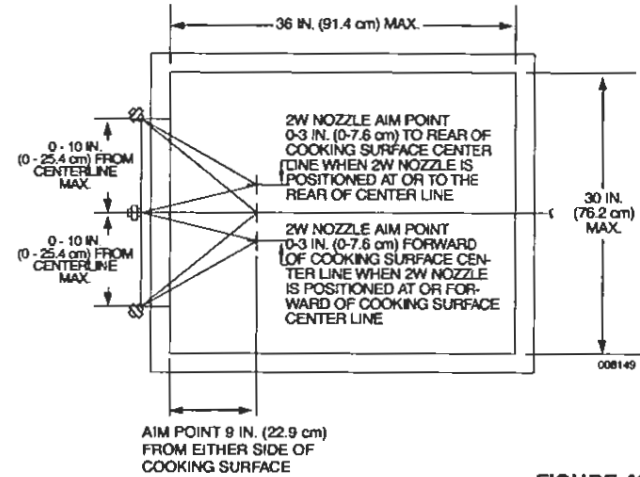

FIGURE 49

FRONT VIEW

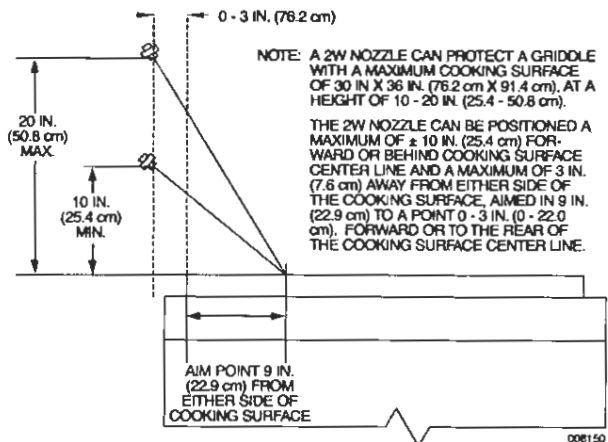

FIGURE 50

► **Griddle Protection 1W (1-Flow) Nozzle – Low Proximity Application**

15 in. to 20 in. (38.1 cm to 50.8 cm) above the cooking surface.

The low proximity 1-flow nozzle application for the protection of griddles requires the 1W nozzle, Part No. 419336.

The nozzle tip is stamped with 1W indicating that this is a one-flow nozzle and must be counted as one flow number.

When using the 1W nozzle for low proximity griddle protection with or without obstruction, the maximum length of the cooking surface to be protected must not exceed 26 in. (66.0 cm). The nozzle must be centered at one end of the maximum 26 in. (66.0 cm) length, aimed along a centerline to a point 20 in. (50.8 cm) from the end of the length, protecting a maximum width of 20.5 in. (52.1 cm).

The 1W nozzle tip must be positioned at or below the obstruction, if present. The protected area begins at the point straight down from the nozzle tip. The nozzle can be positioned above the edge of the hazard area to be protected. See Figures 51 and 52.

Note: If the hazard area exceeds the single nozzle coverage listed above, additional nozzles will be required. The additional nozzle can be positioned in front at high proximity or at the side at low proximity.

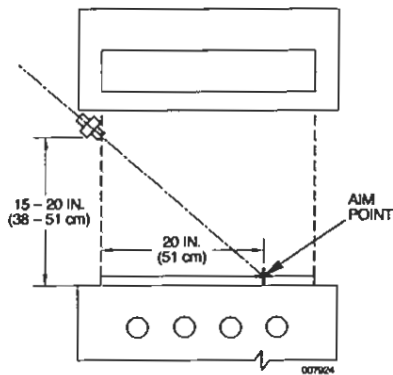

FIGURE 51

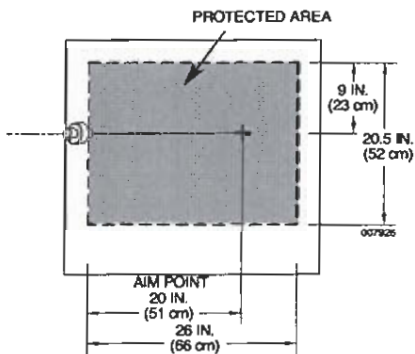

FIGURE 52

Chain Broiler Protection

The following listed protection guidelines can be applied to any manufacturer's chain broilers, if the chain broiler meets the specified parameters. Chain broilers utilizing catalytic converters can be protected from overhead using model specific protection identified in the "Specific Application by Model" section in System Design. Or, they can be protected with standard 1N nozzle horizontal chain broiler protection with the nozzles positioned at either end of the chain broiler openings. Refer to the Horizontal Chain Broiler Protection section for specific design information.

Horizontal Chain Broiler Protection

The R-102 system can use two 1N Nozzles (Part No. 419335) for horizontal chain broiler protection. The nozzle tip is stamped 1N, indicating that this is a one-flow nozzle and must be counted as one flow number (total of two flow numbers for each chain broiler being protected).

Two 1N nozzles are always needed for chain broiler protection when the hazard area to be protected does not meet the "Overhead Broiler Protection" requirements. The maximum internal size of the broiler is 43 x 31 in. (109 cm x 79 cm). The nozzles must be positioned at each end of the enclosed cooking chamber 1 to 3 in. (2.5 to 7.5 cm) above the surface of the chain and a maximum distance of 4 in. (10 cm) away from the broiler opening. The nozzles may be mounted at either corner as long as they are at opposite ends of the chain broiler and positioned to discharge diagonally across the top of the chain. See Figures 53 and 54.

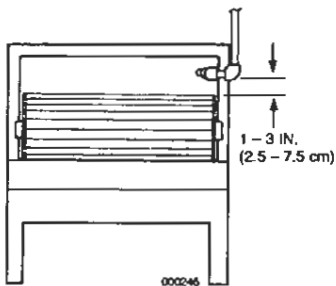
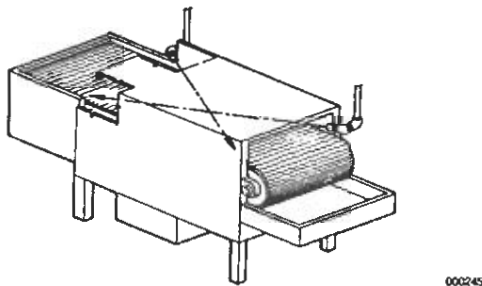

FIGURE 53

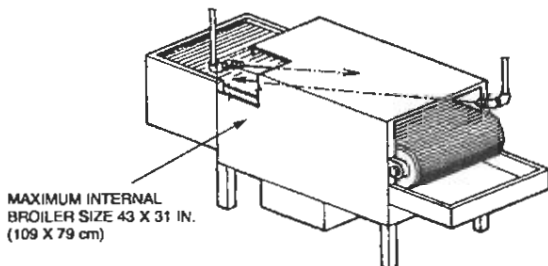

FIGURE 54

Overhead Chain Broiler Protection

The R-102 system can use two 1W Nozzles (Part No. 419336) for overhead chain broiler protection. The nozzle tip is stamped with 1W, indicating that this is a one-flow nozzle and must be counted as one flow number.

Overhead protection is only available for chain broilers with exhaust opening dimensions that are not less than 60% of the internal broiler length and not less than 60% of the internal broiler width, to a minimum size of 12 in. x 12 in. (30.5 x 30.5 cm). Internal broiler size can not be larger than 32 in. x 34 in. (81 x 86 cm).

When overhead protection is used, the nozzles must be centered above the exhaust opening within 4 to 8 in. (10 to 20 cm) of each other and they must be located 10 to 26 in. (25 to 66 cm) above the top of the broiler surface. See Figure 55.

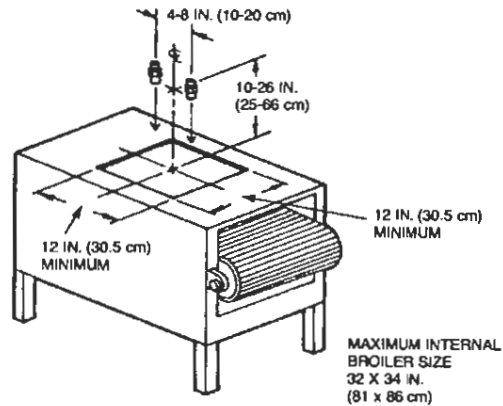

FIGURE 55

The nozzles may vary in position as long as they are evenly spaced from the exhaust center and are always 180° opposite of each other. If the opening is not square, the nozzles must be positioned along the centerline, parallel to the longest side of the opening. See Figure 56.

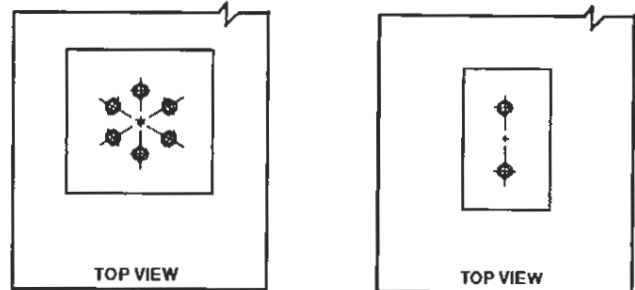

FIGURE 56

Note: The CB Metal Blow-off Cap must be used when using chain broiler protection.

Overhead Chain Broiler Protection (Continued)

Example No. 1 – Internal broiler size is 24 in. long x 20 in. wide (61 x 51 cm), with an opening of 16 in. x 16 in. (40.6 x 40.6 cm).

To determine minimum opening size, multiply the internal length and the internal width by 0.6:

Length of opening – 24 in. x 0.6 = 14.4 in.
 (61 cm x 0.6 = 36.6 cm)

Width of opening – 20 in. x 0.6 = 12.0 in.
 (51 cm x 0.6 = 30.5 cm)

The minimum allowable opening for overhead protection would be 14.4 in. x 12.0 in. (36.6 x 30.5 cm).

This example would be acceptable for overhead protection.

Example No. 2 – Internal broiler size is 30 in. long x 24 in. wide (76 x 61 cm) with an opening of 22 in. x 12 in. (56 x 30 cm).

To determine minimum opening size, multiply internal length and internal width by 0.6:

Length of opening – 30 in. x 0.6 = 18.0 in.
 (76 cm x 0.6 = 45.7 cm)

Width of opening – 24 in. x 0.6 = 14.4 in.
 (61 cm x 0.6 = 36.6 cm)

Minimum allowable opening for overhead protection would be 18 in. x 14.4 in. (45.7 x 36.6 cm).

Because this broiler has an opening of 22 in. x 12 in., the 12 in. width is below the minimum allowable calculated dimension of 14.4 in. (36.6 cm) and therefore would not be acceptable for overhead protection.

Salamander Broiler Protection

The R-102 system uses three different nozzle locations for salamander broiler protection. All of the design options require a one-flow nozzle.

Salamander Broiler Protection – 1N (1-Flow) Nozzle Overhead

A salamander broiler with a maximum hazard area (internal broiler chamber) of 16 in. (41 cm) deep x 29 in. (74 cm) wide can be protected using a 1N nozzle, Part No. 419335. The nozzle tip is stamped with 1N, indicating that this is a one-flow nozzle.

The single 1N nozzle must be located directly in line with either vertical edge of the broiler opening, 6 in. (15 cm) to 12 in. (30 cm) in front of the broiler, and 0 in. to 12 in. (30 cm) above the top of the broiler. The nozzle must be aimed at the center of the broiler opening. See Figure 57a.

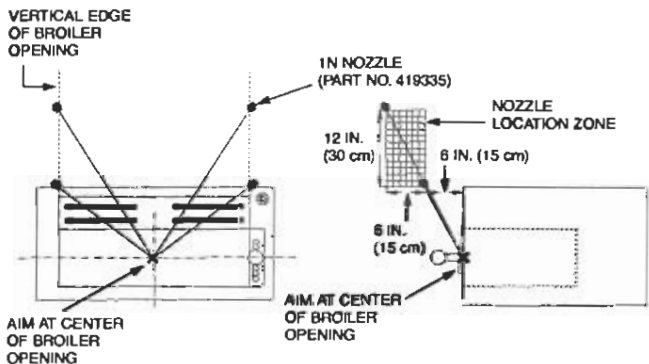

FIGURE 57a
008426

Salamander Broiler Protection – 1F (1-Flow) Nozzle Overhead

A salamander broiler with a maximum hazard area (internal broiler chamber) of 15 in. (38 cm) deep x 31 in. (79 cm) wide can be protected using a 1F nozzle, Part No. 419333. The nozzle tip is stamped with 1F, indicating that this is a one-flow nozzle.

The single 1F nozzle must be located directly in line with the center of the broiler opening, 8 in. (20 cm) to 12 in. (30 cm) in front of the broiler and 12 in. (30 cm) to 18 in. (46 cm) above the top of the broiler. The nozzle must be aimed at the center of the top broiler opening when the grate is located in the middle position. The nozzle must be orientated so the nozzle tip flats are parallel with the grate left to right centerline. See Figure 57b.

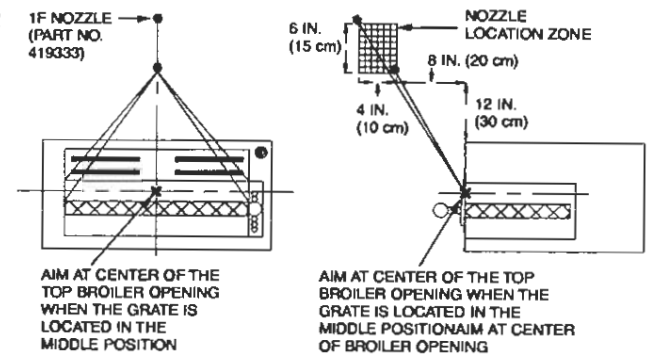

FIGURE 57b
008426

Salamander Broiler Protection – 1N (1-Flow) Nozzle Local

A salamander broiler with a maximum hazard area (internal broiler chamber) of 15 in. (38 cm) deep x 31 in. (79 cm) wide can be protected using a 1N nozzle, Part No. 419335. The nozzle tip is stamped with 1N, indicating that this is a one-flow nozzle.

The single 1N nozzle must be located above the grate on either vertical edge of the broiler opening. The nozzle must be aimed at the center of the grates. See Figure 57c.

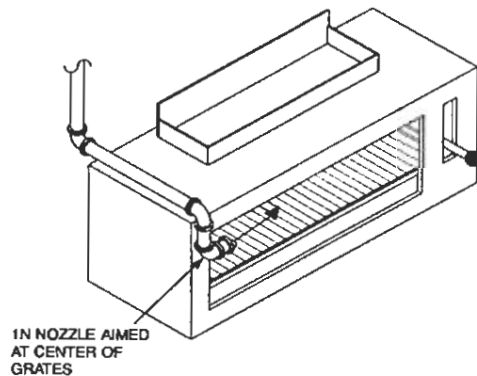

FIGURE 57c
008426

► Upright Broiler Protection

The R-102 system uses two 1/2N Nozzles (Part No. 419334) for all upright broiler protection. The nozzle tip is stamped 1/2N, indicating that this is a half-flow nozzle. A pair of these nozzles will equal one flow number.

Two 1/2N nozzles will protect a maximum hazard area (internal broiler chamber) of 30 in. x 32.5 in. (76 cm x 82.5 cm). These nozzles must always be used in pairs on an upright broiler. One nozzle must be positioned above the grate and pointed at the back opposite corner of the broiler chamber. The second nozzle must be pointed down into the center of the drip pan through the open slot. See Figure 58.

► UPRIGHT BROILER

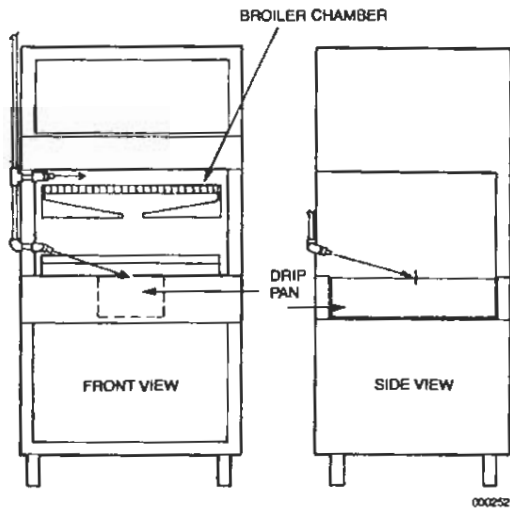

FIGURE 58

Gas-Radiant/Electric Char-Broiler Protection

The R-102 system uses the 1N nozzle, (Part No. 419335) for gas-radiant/electric char-broiler protection.

The nozzle tip on the 1N nozzle is stamped with a 1N, indicating that this is a one-flow nozzle and must be counted as one flow number.

One 1N nozzle will protect a hazard with a maximum length of 36 in. (91 cm) and a total cooking area which does not exceed 864 in.² (5574 cm²). The nozzle tip must be located 15 to 40 in. (38 to 102 cm) above the hazard surface. When using this nozzle for gas-radiant/electric char-broiler protection, the nozzle must be positioned anywhere along or within the perimeter of the maximum cooking area and shall be aimed at the center of the cooking surface. See Figure 59.

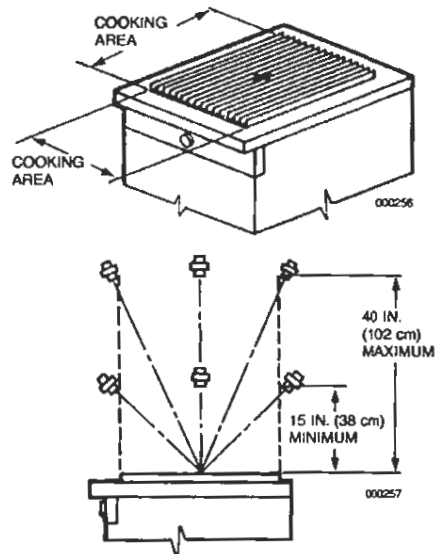

FIGURE 59

Lava Rock (Ceramic) Char-Broiler Protection

The R-102 system uses the 1N Nozzle (Part No. 419335) for all lava rock char-broiler protection. The nozzle tip is stamped with 1N, indicating that this is a one-flow nozzle and must be counted as one flow number.

One 1N nozzle will protect a hazard which has a maximum length of 24 in. (61 cm) and a total cooking area which does not exceed 312 in.² (2013 cm²). The nozzle tip must be located 18 to 35 in. (46 to 89 cm) above the hazard surface. When using this nozzle for lava rock (ceramic) char-broiler protection, the nozzle must be positioned anywhere along or within the perimeter of the maximum cooking area and angled to the center. See Figure 60.

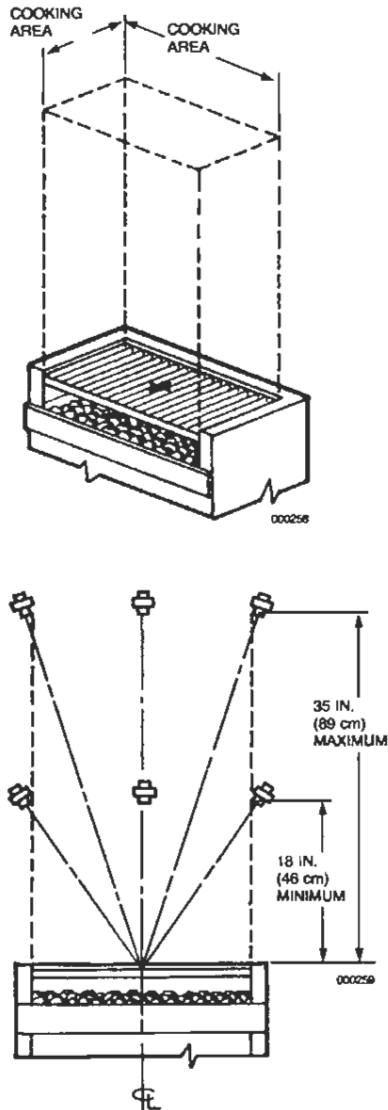

FIGURE 60

Natural Charcoal Broiler Protection

The R-102 system uses the 1N Nozzle (Part No. 419335) for all natural charcoal broiler protection. The nozzle tip is stamped with 1N indicating that this is a one-flow nozzle and must be counted as one flow number.

One 1N nozzle will protect a hazard area which has a maximum length of 24 in. (61 cm) and a total cooking area which does not exceed 288 in.² (1858 cm²). The nozzle tip must be located 18 to 40 in. (46 to 102 cm) above the hazard surface. When using this nozzle for natural charcoal broiler protection, the nozzle must be positioned anywhere along or within the perimeter of the maximum cooking area and aimed at the center of the cooking surface. See Figure 61.

The coverage of such appliances only applies when the depth of the charcoal does not exceed 4 in. (10 cm).

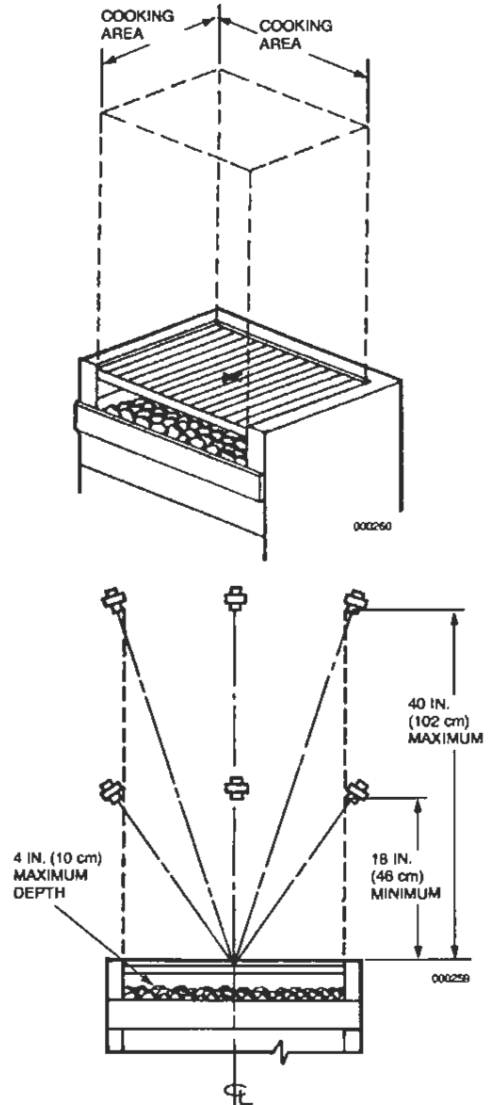

FIGURE 61

Alternate Ceramic/Natural Charcoal Char-broiler Protection

The R-102 system may also use the 3N nozzle (Part No. 419338) for all ceramic (lava rock) and natural charcoal char-broiler protection. The nozzle tip is stamped with 3N, indicating that this is a three-flow nozzle and must be counted as three flow numbers.

One 3N nozzle will protect a hazard which has a maximum length of 30 in. (76 cm) and a total cooking area which does not exceed 720 in.² (4645 cm²). The nozzle tip must be located 14 to 40 in. (36 to 102 cm) above the hazard surface. The nozzle must be positioned anywhere along or within the perimeter of the maximum cooking area and angled to the center. See Figure 62.

For natural charcoal char-boiler protection, this coverage only applies when the depth of the charcoal does not exceed 4 in. (10 cm).

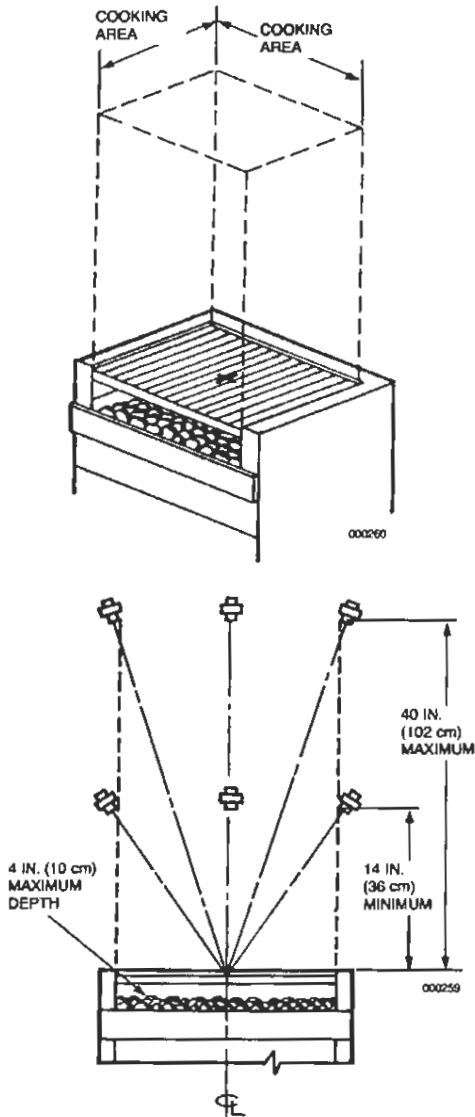

FIGURE 62

Wood Fueled Char-Broiler Protection

The R-102 system uses the 3N Nozzle (Part No. 419338) for mesquite char-broiler protection. The nozzle tip is stamped with 3N indicating that this is a three-flow nozzle and must be counted as three flow numbers.

One 3N nozzle will protect a hazard which has a maximum length of 30 in. (76 cm) and a total cooking area which does not exceed 720 in.² (4645 cm²). The nozzle tip must be located 14 to 40 in. (36 to 102 cm) above the hazard surface. The nozzle must be positioned anywhere along or within the perimeter of the maximum cooking area and aimed at the center of the cooking surface. See Figure 63.

Mesquite logs and pieces, no larger than 4 in. (10 cm) in diameter, may be protected with a maximum allowable wood depth of 6 in. (15 cm).

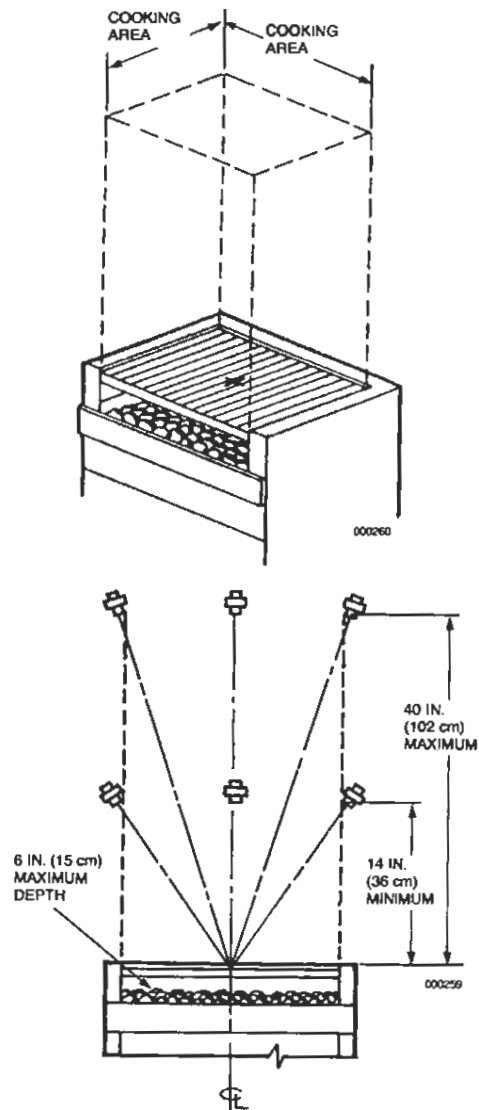

FIGURE 63

Wok Protection

The R-102 system uses two different nozzles for the protection of woks.

1. A 260 nozzle, Part No. 419341, will protect a wok 14 in. (36 cm) minimum diameter up to 30 in. (76 cm) maximum diameter. The wok depth must be no less than 3.75 in. (9.5 cm) and no greater than 8 in. (20 cm).

The nozzle tip is stamped with 260 indicating that this is a two-flow nozzle and must be counted as two flow numbers.

When using this nozzle, the nozzle must be positioned as shown in Figure 64.

NOZZLE MUST BE POSITIONED WITHIN 1 IN. (2 cm) RADIUS OF THE CENTER OF THE WOK, POINTED VERTICALLY DOWN

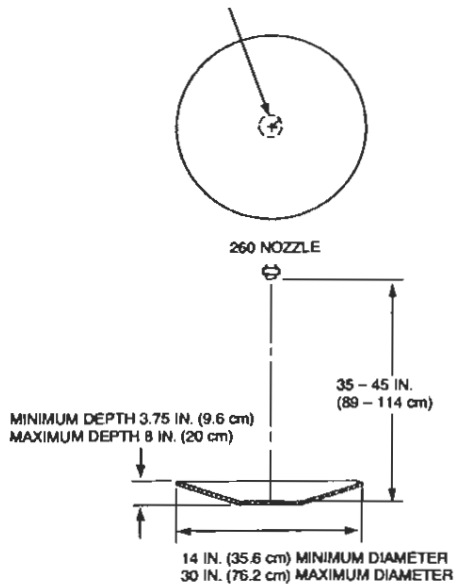

FIGURE 64
000261

2. A 1N Nozzle, Part No. 419335, will protect a wok 11 in. (28 cm) minimum diameter up to 24 in. (61 cm) maximum diameter. The wok depth must be no less than 3 in. (8 cm) and no greater than 6 in. (15 cm). The nozzle tip is stamped with 1N indicating that this is a one-flow nozzle and must be counted as one flow number. When using this nozzle, the nozzle must be positioned anywhere along or within the perimeter of the wok, aimed at the center, 30 in. to 40 in. (76 to 102 cm) above the hazard surface, as shown in Figure 65.

NOTICE

When using this type of wok protection, only 5 flow numbers are allowed on a 1 1/2 gal (5.7 L) system, and only 11 flow numbers are allowed on a 3 gal (11.4 L) system.

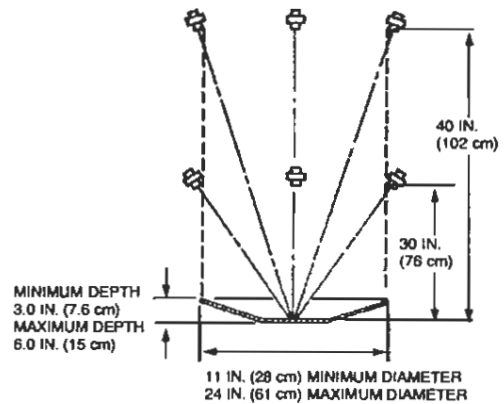

FIGURE 65
000261

Nozzle Application Chart

The following chart has been developed to assist in calculating the quantity and type of nozzle required to protect each duct, plenum, or appliance.

NOTICE

This chart is for general reference only. See complete details for each type of hazard.

<u>Hazard</u>	<u>Maximum Hazard Dimensions</u>	<u>Minimum Nozzle Quantity</u>	<u>Nozzle Heights</u>	<u>Nozzle Part No.</u>	<u>Nozzle Tip Stamping – Flow No.</u>
Duct or Transition (Single Nozzle)	Length – Unlimited Perimeter – 50 in. (127 cm) Diameter – 16 in. (40.6 cm)	1	–	430912	1W
Duct or Transition (Single Nozzle)	Length – Unlimited Perimeter – 100 in. (254 cm) Diameter – 31 7/8 in. (81 cm)	1	–	419337	2W
Duct or Transition (Dual Nozzle)	Length – Unlimited Perimeter – 150 in. (381 cm) Diameter – 48 in. (122 cm)	2	–	419337	2W
Electrostatic Precipitator (At Base of Duct)	Individual Cell	1	–	419334	1/2N
Plenum (Horizontal Protection)	Length – 10 ft (3.1 m)	1	–	419335	1N
Plenum (Horizontal Protection)	Length – 6 ft (1.8 m) Width – 4 ft (1.2 m)	1	–	430192	1W
		1	–	419336	1W
Plenum (Vertical Protection)	Length – 4 ft (1.2 m) Width – 4 ft (1.2 m)	1	–	419336	1W
Fryer (Split or Non-Split Vat)	Maximum Size (without drip board) 14 in. (36 cm) x 15 in. (38 cm) Low Proximity	1	13 – 16 in. (33 – 41 cm)	419342	290
		1	16 – 27 in. (41 – 69 cm)	419342	290
Fryer (Split or Non-Split Vat)*	Maximum Size (without drip board) 15 in. (38 cm) x 14 in. (36 cm) High Proximity Medium Proximity	1	27 – 47 in.	419339	230
		1	20 – 27 in.	419340	245
Fryer (Non-Split Vat Only)	Maximum Size (without drip board) 19 1/2 in. (49.5 cm) x 19 in. (48.2 cm) High Proximity Low Proximity	1	21 – 34 in.	419338	3N
		1	13 – 16 in.	419342	290
		1	25 – 35 in. (64-89 cm)	419338	3N

► * For multiple nozzle protection of single fryers, see detailed information on Pages 4-10 and 4-11.

Nozzle Application Chart (Continued)

<u>Hazard</u>	<u>Maximum Hazard Dimensions</u>	<u>Minimum Nozzle Quantity</u>	<u>Nozzle Heights</u>	<u>Nozzle Part No.</u>	<u>Nozzle Tip Stamping – Flow No.</u>	
Fryer (Non-Split Vat Only)*	Maximum Size (with drip board) 21 in. (53 cm) x 14 in. (36 cm) (Fry Pot must not exceed 15 in. x 14 in. (38 cm x 36 cm))					
	High Proximity	1	27 – 47 in.	419339	230	
	Medium Proximity	1	20 – 27 in.	419340	245	
	Maximum Size (with drip board) 25 3/8 in. (64.4 cm) x 19 1/2 in. (49.5 cm) (Fry pot side must not exceed 19 1/2 in. (49.5 cm) x 19 in. (48.2 cm))					
	High Proximity	1	21 – 34 in.	419338	3N	
	Low Proximity	1	13 – 16 in.	419342	290	
Fryer (Split or Non-Split Vat)	Maximum Size (with drip board) 18 in. (45.7 cm) x 27 3/4 in. (70.5 cm)					
	High Proximity	1	25 – 35 in. (64-89 cm)	419338	3N	
Fryer (Split or Non-Split Vat)	Maximum Size (with drip board) 14 in. (36 cm) x 21 in. (53 cm)					
	Low Proximity	1	13 – 16 in. (33 – 41 cm)	419342	290	
Fryer (Split or Non-Split Vat)	Maximum Size (with drip board) 14 1/2 in. (37 cm) x 26 1/2 in. (67 cm)					
	Medium Proximity	1	16 – 27 in. (41 – 69 cm)	419342	290	
▶ Range	Longest Side (High Proximity) 32 in. (81 cm) Area – 384 sq. in. (2477 sq cm)	1	30 – 40 in. (76 – 102 cm)	419335	1N	
	Longest Side (Low Proximity) 24 in. (61 cm) Area – 432 in. ² (2787 cm ²)	1	15 – 20 in. (38 – 51 cm)	419335	1N	
▶	Longest Side 28 in. (71 cm) Area – 336 sq in. (2168 sq cm)					
	Longest Side 28 in. (71 cm) Area – 672 sq in. (4335 sq cm)	1	40 – 48 in. (102 – 122 cm) (With Backshelf)	419333	1F	
▶	Longest Side (High Proximity) 28 in. (71 cm) Area – 672 sq in. (4335 sq cm)	1	40 – 50 in. (102 – 127 cm)	419340	245	
	Longest Side (Medium Proximity) 32 in. (81 cm) Area – 768 sq in. (4955 sq cm)	1	30 – 40 in. (76 – 102 cm)	419341	260	

▶ * For multiple nozzle protection of single fryers, see detailed information on Pages 4-10 and 4-11.

Nozzle Application Chart (Continued)

<u>Hazard</u>	<u>Maximum Hazard Dimensions</u>	<u>Minimum Nozzle Quantity</u>	<u>Nozzle Heights</u>	<u>Nozzle Part No.</u>	<u>Nozzle Tip Stamping – Flow No.</u>
Range (Continued)	Longest Side (Low Proximity) 36 in. (91 cm) Area – 1008 sq in. (6503 sq cm)	2	15 – 20 in. (38 – 51 cm)	419342	290
Griddle	Longest Side (High Proximity) 48 in. (122 cm) Area – 1440 sq in. (9290 sq cm)	1	30 – 50 in. (76 – 127 cm) (perimeter located)	419341	260
	Longest Side (High Proximity) 30 in. (76 cm) Area – 720 sq in. (4645 sq cm)	1	30 – 50 in. (76 – 127 cm) (center located)	419342	290
▶	Longest Side (High Proximity) 36 in. (91 cm) Area – 1080 sq in. (6968 sq cm)	1	35 – 40 in. (89 – 102 cm) (perimeter located)	419335/435672	1N/1NSS
	Longest Side (Medium Proximity) 48 in. (122 cm) Area – 1440 sq in. (9290 sq cm)	1	20 – 30 in. (51 – 76 cm) (perimeter located)	419342	290
▶	Longest Side (Low Proximity) 26 in. (66 cm) Area – 533 in. ² (3439 cm ²)	1	15 – 20 in. (38 – 51 cm) (center located)	4193336	1W
	Longest Side (Low Proximity) 36 in. (91 cm) Area – 1080 in. ² (6968 cm ²)	1	10 – 20 in. (25 – 51 cm) (perimeter located)	419337	2W
	Longest Side (Low Proximity) 48 in. (122 cm) Area – 1440 sq in. (9290 sq cm)	1	10 – 20 in. (25 – 51 cm) (perimeter located)	419343	2120
▶ Chain Broiler* (Overhead Protection)	Longest Side – 34 in. (86 cm) Area – 1088 sq in. (7019 sq cm)	2	10 – 26 in. (25 – 66 cm)	419336/432527	1W/1WSS
▶ Chain Broiler (Horizontal Protection)	Length – 43 in. (109 cm) Width – 31 in. (79 cm)	2	1 – 3 in. (3 – 8 cm)	419335/435672	1N/1NSS
▶ Gas-Radiant Char-Broiler	Longest Side – 36 in. (91 cm) Area – 864 sq in. (5574 sq cm)	1	15 – 40 in. (38 – 102 cm)	419335/435672	1N/1NSS
▶ Electric Char-Broiler	Longest Side – 34 in. (86 cm) Area – 680 sq in. (4388 sq cm)	1	20 – 50 in. (51 – 127 cm)	419335/435672	1N/1NSS
▶ Lava-Rock Broiler	Longest Side – 24 in. (61 cm) Area – 312 sq in. (2013 sq cm)	1	18 – 35 in. (46 – 89 cm)	419335/435672	1N/1NSS
▶ Natural Charcoal Broiler	Longest Side – 24 in. (61 cm) Area – 288 sq in. (1858 sq cm)	1	18 – 40 in. (46 – 102 cm)	419335/435672	1N/1NSS

Nozzle Application Chart (Continued)

Hazard	Maximum Hazard Dimensions	Minimum Nozzle Quantity	Nozzle Heights	Nozzle Part No.	Nozzle Tip Stamping – Flow No.
Lava-Rock or Natural Charcoal Char-Broiler	Longest Side – 30 in. (76 cm) Area – 720 sq in. (4645 sq cm)	1	14 – 40 in. (36 – 102 cm)	419338	3N
Wood Fueled Char-Broiler	Longest Side – 30 in. (76 cm) Area – 720 sq in. (4645 sq cm)	1	14 – 40 in. (36 – 102 cm)	419338	3N
Upright Broiler	Length – 32.5 in. (82.5 cm) Width – 30 in. (76 cm)	2	–	419334	1/2N
▶ Salamander Broiler	Length – 29 in. (74 cm) Width – 16 in. (41 cm)	1	–	419335	1N
	Length – 31 in. (79 cm) Width – 15 in. (38 cm)	1	–	419333	1F
	Length – 31 in. (79 cm) Width – 15 in. (38 cm)	1	–	419335	1N
Wok	14 in. – 30 in. (36 – 76 cm) Diameter 3.75 – 8.0 in. (9.5 – 20 cm) Deep	1	35 – 45 in. (89 – 114 cm)	419341	260
▶	11 in. – 24 in. (28 – 61 cm) Diameter 3.0 – 6.0 in. (8 – 15.2 cm) Deep		30 – 40 in. (76 – 102 cm)	419335/435672	1N/1NSS

* Minimum chain broiler exhaust opening – 12 in. x 12 in. (31 cm x 31 cm), and not less than 60% of internal broiler size.

SPECIFIC APPLICATION BY MODEL

Due to the configuration, application, and/or additional features that pose protection problems using conventional protection, noted in the guidelines previously addressed, the following appliances/applications are considered hazard specific.

The following hazard specific applications have been individually tested and listed by make and model number of the equipment designated.

Dean Industries Gas Fryer, Model 2424 GTI, 120,000 BTU/hr. Rating

This specialized gas fryer can be protected with a combination of a 290 nozzle, Part No. 419342, and a 1W nozzle, Part No. 419336, for low proximity (7 3/4 – 8 in. nozzle height only) and two (2) 230 nozzles, Part No. 419339, for high proximity (45 in. nozzle height only).

The maximum dimension of the fry pot is 24 in. x 24 in. (61 x 61 cm).

Nozzles must be positioned and aimed as shown in Figure 66.

Note: For low proximity protection, see Special Piping Layout in Figure 67.

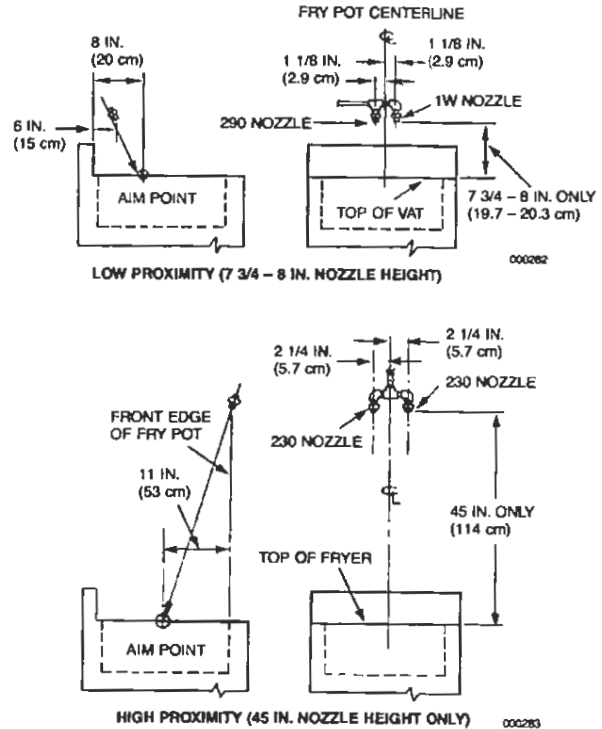

FIGURE 66

Dean Industries Model GTI Gas Fryer Special Piping Layout

Section A (Tank to Hood Penetration) Piping Limitations

- Maximum Length: 30 ft (9.1 m)
- Maximum Rise: 6 ft (1.8 m)
- Maximum Number of 90° Elbows: 7
- Maximum Number of Tees: 0

Section B (Hood Penetration to Nozzles) Piping Limitations

1. Piping configuration shall be as shown with ±1/4 in. tolerance on dimensions.
2. All nozzles shall be at the same elevation.
3. Each pair of appliance nozzles shall be equally spaced from left-to-right centerline of fryer.

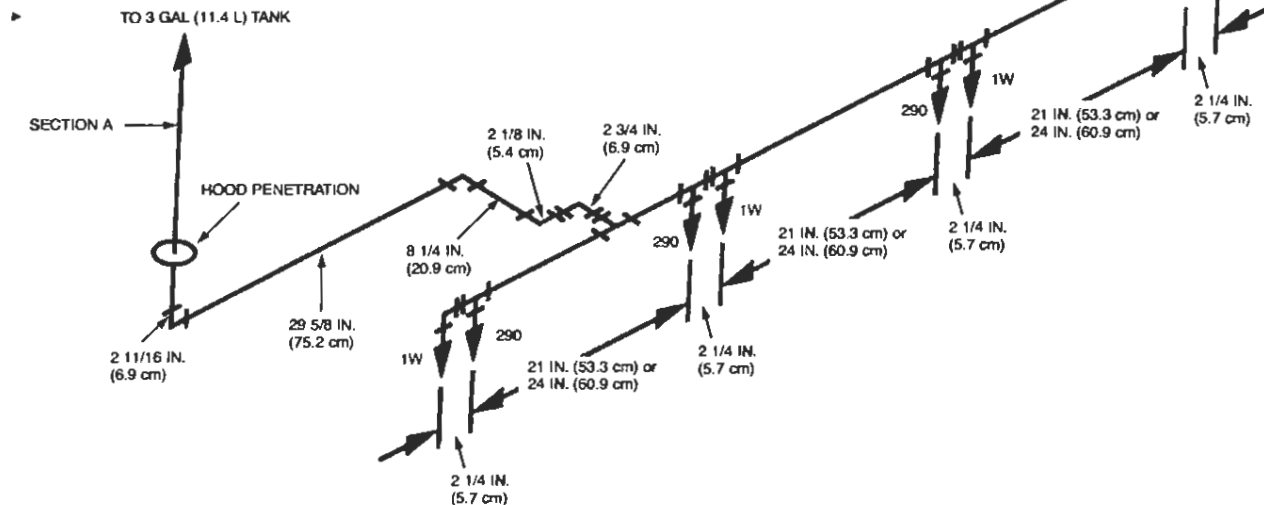

SPECIFIC DISCHARGE PIPING FOR LOW PROXIMITY PROTECTION OF (4) FOUR DEAN INDUSTRIES MODEL GTI GAS FRYERS

FIGURE 67

SPECIFIC APPLICATION BY MODEL (Continued)

Far West Hospitality Products Gas Fryer, Model PAR-1-20, 63000 BTU/hr Rating

This specialized gas fryer can be protected with a single, 290 nozzle, Part No. 419342.

The maximum dimension of the fry pot is 21 in. x 21 in. (53 x 53 cm).

The 290 nozzle must be located on the front-to-rear centerline and aimed at the center of the cooking surface. See Figure 68.

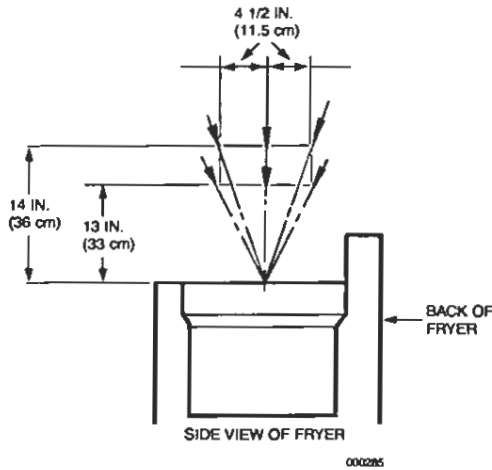

290 NOZZLE LOCATED ON FRONT-TO-REAR CENTERLINE ± 4.5 IN. (11.4 cm) FROM SIDE TO SIDE CENTERLINE AND AIMED AT CENTER OF COOKING AREA.

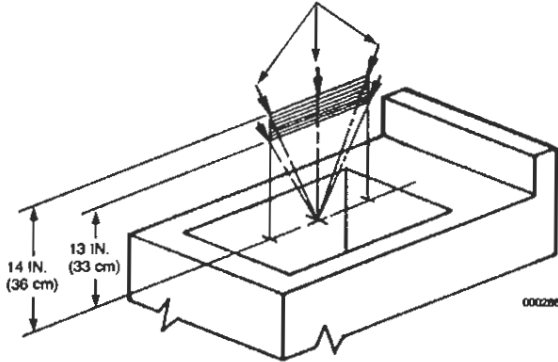

FIGURE 68

Frymaster 14 KW – 208V Electric Fryer, Model MACH 14 Series

This specialized single vat electric fryer can be protected either with a single 230 nozzle, Part No. 419339, located 27 in. to 47 in. (69 cm to 120 cm) above the top surface of the fryer or with a single 245 nozzle, Part No. 419340, located 20 in. to 27 in. (51 cm to 69 cm) above the top surface of the fryer.

Either nozzle must be located anywhere along or within the perimeter of the cooking surface and aimed at the midpoint. See Figure 69. The maximum size of the fry pot (without drip board) is 13 3/4 in. x 16 3/4 in. (35 cm x 42.6 cm) and the maximum size of the cooking surface (with drip board) is 13 3/4 in. x 20 7/8 in. (35 cm x 53 cm). The vat may be divided in half to make two split vats.

230 NOZZLE TIP OR 245 NOZZLE TIP ANYWHERE ALONG OR WITHIN THE PERIMETER OF THE COOKING SURFACE AND AIMED AT THE MIDPOINT.

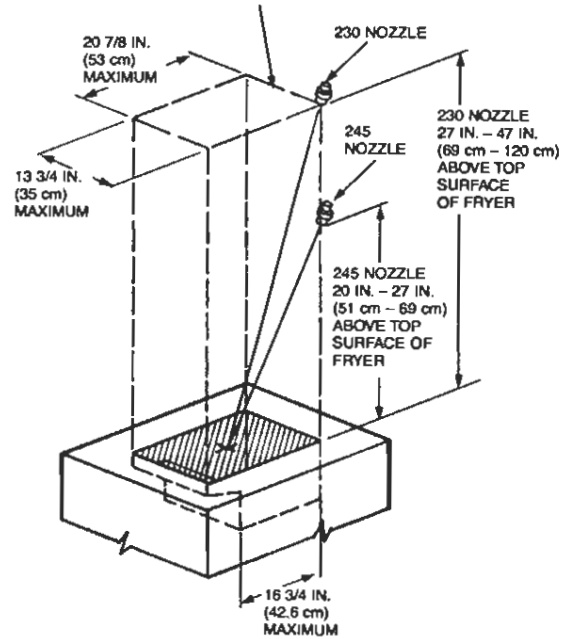

FIGURE 69

SPECIFIC APPLICATION BY MODEL (Continued)

McDonald Fryer (Nozzle Heights of Less Than 20 In.)

When the 245 nozzle is used to protect McDonald's fryers at heights less than 20 in. (51 cm) above the top of the fryer, the following appliance and distribution piping rules shall apply:

1. Each McDonald's gas or electric fryer shall be protected by one 245 nozzle, Part No. 419340. The fryer vat dimensions for one full vat or two split vats shall not exceed 14 in. x 15 in. (36 cm x 38 cm) without the dripboard and 14 in. x 21 in. (36 cm x 53 cm) with the dripboard.

The heat input rating of the fryer shall not exceed 122,000 BTU/HR.

The 245 nozzle shall be located 18 in. to 20 in. (46 cm to 51 cm) above the top of the fryer vat, 2 in. to 2 1/4 in. (5 cm to 5.7 cm) to the right or left of the front-to-rear vat centerline, and 0 to 3 1/4 in. (0 cm to 8 cm) forward of the right-to-left vat centerline, and aimed at the vat center point. See Figure 70.

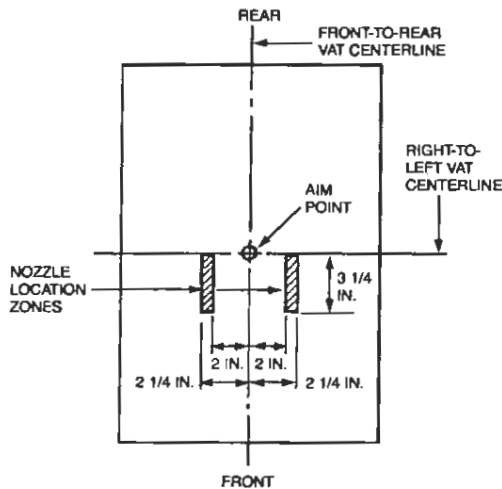

FIGURE 70
002297

2. The distance between the start of the first branch line and the start of the last branch line shall not exceed 79 in. (201 cm).
3. The total length of all branch lines shall not exceed 162 in. (412 cm).
4. The 3 gallon agent tank shall be elevated above the connections between the supply and branch lines.
5. The requirements of the following table shall not be exceeded:

Requirement	Supply Line	Duct Branch Line	Plenum Branch Line	Appliance Branch Line
Pipe Size	3/8 in.	3/8 in.	3/8 in.	3/8 in.
Maximum Length	140 in. (356 cm)	67 in. (170 cm)	6 in. (15 cm)	42 in. (107 cm)
Minimum Length	81 in. (206 cm)	4 in. (10 cm)	4 in. (10 cm)	17 in. (43 cm)
Maximum 90° Elbows	5	3	1	6
Maximum Tees	0	1	1	1
Maximum Flow Numbers	11	2	1	2
Minimum Flow Numbers	5	0	0	1/2

► **SPECIFIC APPLICATION BY MODEL (Continued)**

Henny Penny Mono Rail Center Lift System – Models 690, 691, 692

- Nozzle Type:** (1) One 1N nozzle, Part No. 419335 (Upper position)
 (1) One 1F nozzle, Part No. 419333 (Lower position)

Nozzle Location:

1N Nozzle (Upper position): From the Tee Block, part No. 434424, position nozzle tip 16 in. (40.6 cm) up from base of fryer surface and 5 in. (12.7 cm) in from right side of appliance back shroud

1F Nozzle (Lower Position): Running down from the Tee Block, Part No. 434424, to the base of the fryer, position the nozzle tip 2 in. (5.1 cm) from back side of fry vat, and 8 in. (20.3 cm) in from the right side of appliance back shroud

Nozzle Aiming Point:

1N Nozzle: At center point of fry vat

1F Nozzle: The 1F nozzle is a flat spray nozzle and the spray must be horizontal to that of the edge of the back lip of the fry vat

System Coverage: Each fryer requires a minimum of 3 gal (11.4 L) of ANSULEX® Low pH agent discharging through the two one-flow nozzles (1N and 1F)

► **Note:** In this application, R-102 agent storage tanks must be pressurized from a dedicated R-102 double-tank nitrogen cartridge. The cartridge utilized for this hazard-specific Henny Penny fryer protection cannot be shared with tanks intended for standard R-102 protection. Standard protection will require an expellant gas cartridge installed in another actuation device such as an ANSUL AUTOMAN regulated release or regulated actuator assembly.

NOTE 1: IT IS RECOMMENDED THAT THE AGENT DISTRIBUTION HOSE KIT, PART NO. 435982, BE UTILIZED DURING SYSTEM INSTALLATION.

NOTE 2: VAT DIMENSIONS –
 16 IN. (40.6 cm) WIDE
 20 1/4 IN. (51.4 cm) LENGTH
 28 1/2 IN. (72.4 cm) DEPTH

MAXIMUM LID HEIGHT ABOVE VAT
 15 IN. (38.1 cm)

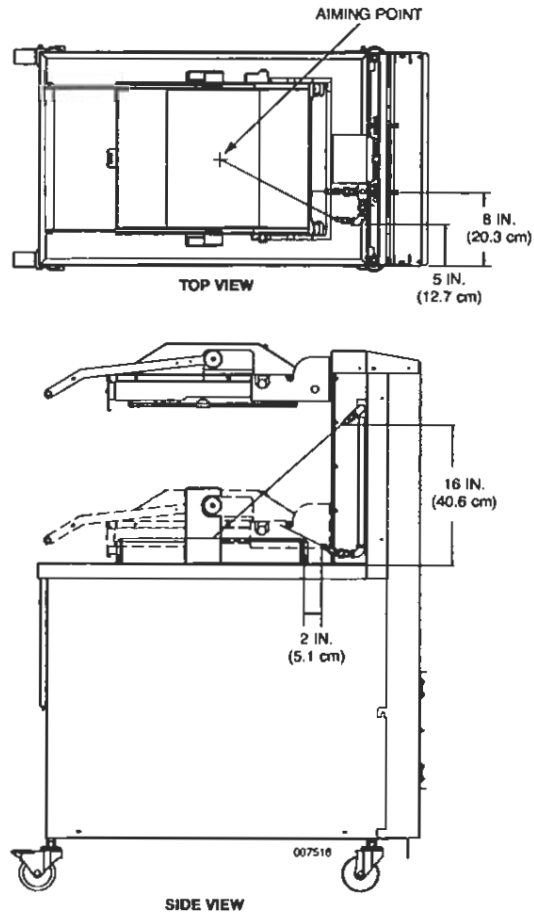
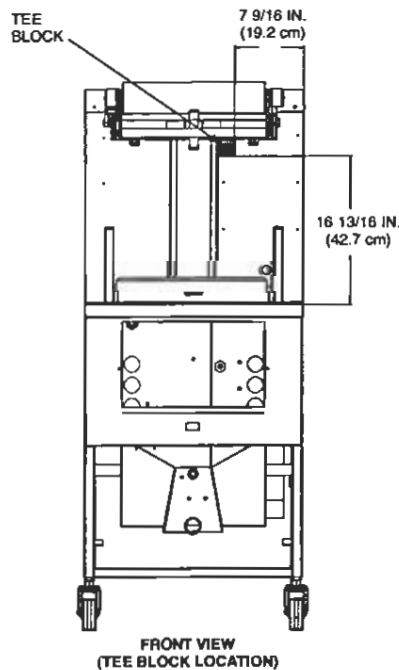

FIGURE 71

SECTION IV – SYSTEM DESIGN

UL EX3470 ULC EX3470 Page 4-34.2

REV. 1 7-1-09

SPECIFIC APPLICATION BY MODEL (Continued)

Henny Penny Dual Lift System – Models 580, 581, 582, 590, 591, 592, 680, 682

Nozzle Type:

1N Nozzle (Upper position): From the Tee Block, part No. 434424, position nozzle tip 16 in. (40.6 cm) up from base of fryer surface and 5 in. (12.7 cm) in from left side of appliance back shroud

1F Nozzle (Lower position): Running down from the Tee Block, Part No. 434424, to the base of the fryer, position the nozzle tip 2 in. (5.1 cm) from back side of fry vat, and 8 in. (20.3 cm) in from the left side of appliance back shroud

Nozzle Aiming Point:

1N Nozzle: At center point of fry vat

1F Nozzle: The 1F nozzle is a flat spray nozzle and the spray must be horizontal to that of the edge of the back lip of the fry vat

System Coverage: Each fryer requires a minimum of 3 gal (11.4 L) of ANSULEX Low pH agent discharging through the two one-flow nozzles (1N and 1F)

Note: In this application, R-102 agent storage tanks must be pressurized from a dedicated R-102 double-tank nitrogen cartridge. The cartridge utilized for this hazard-specific Henny Penny fryer protection cannot be shared with tanks intended for standard R-102 protection. Standard protection will require an expellant gas cartridge installed in another actuation device such as an ANSUL AUTOMAN regulated release or regulated actuator assembly.

NOTE 1: IT IS RECOMMENDED THAT THE AGENT DISTRIBUTION HOSE KIT, PART NO. 435982, BE UTILIZED DURING SYSTEM INSTALLATION.

NOTE 2: VAT DIMENSIONS –
 16 IN. (40.6 cm) WIDE
 20 1/4 IN. (51.4 cm) LENGTH
 28 1/2 IN. (72.4 cm) DEPTH

MAXIMUM LID HEIGHT ABOVE VAT
 15 IN. (38.1 cm)

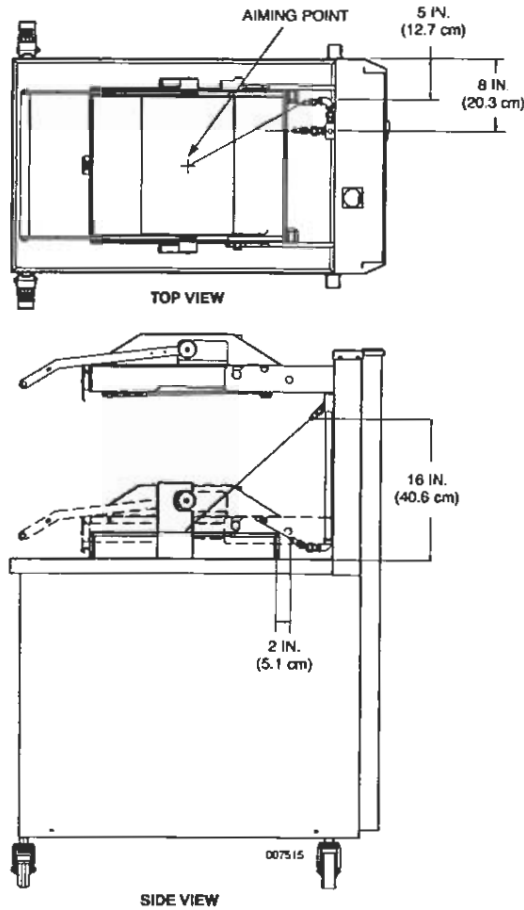
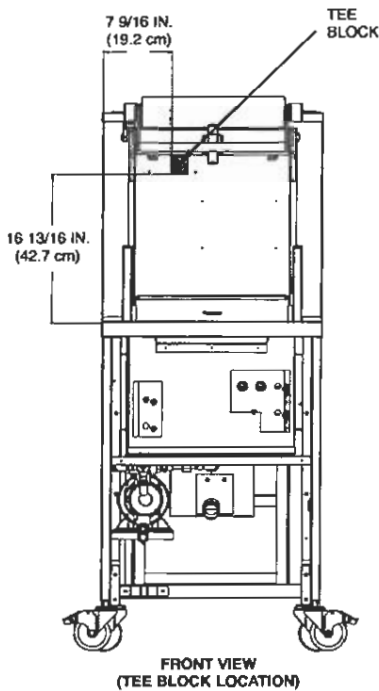
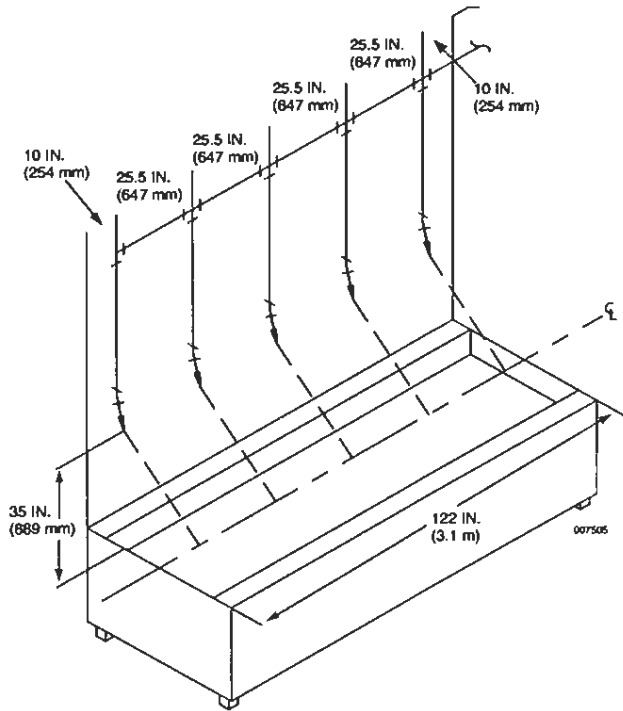

FIGURE 72

Dunkin Donuts Fryer Model DD400CGF

- **Nozzle Type:** 3N Nozzle (Part No. 419338)
- **Nozzle Spacing:** 11.5 in. (292 mm) maximum from end of fryer and 25.5 in. (647 mm) maximum on centers
- **Nozzle Height:** 35 in. (889 mm) above top of appliance
- **Nozzle Position:** 2 in. (51 mm) in from inside edge of fry vat
- **Nozzle Aim Point:** Along the centerline of fry vat



Fryer Specifications:

- **Vat Size:**
 Length: 122 in. (310 cm)
 Width: 31.3 in. (79.5 cm)
 Depth: 11 in. (28 cm)
- **BTU Rating:** 360k
- **Vat Oil Capacity:**
 1250 lb (567 kg)

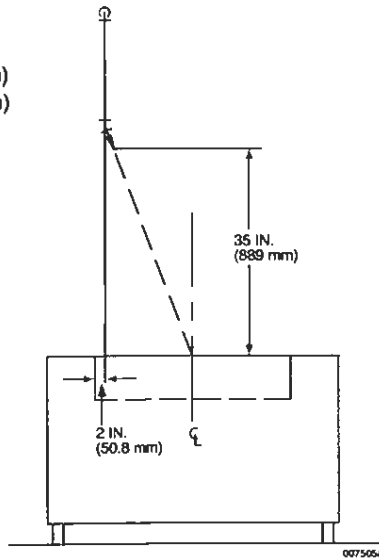

FIGURE 73

Krispy Kreme Fryers – Models 150 D/H, 270 D/H, 600 D/H, and 1000 D/H

- Nozzle Type:** 3N Nozzle (Part No. 419338)
- Nozzle Spacing:** 11.5 in. (29.2 cm) maximum from end of fryer and on maximum 25.5 in. (64.8 cm) centers
- Nozzle Height:** 35 in. (88.9 cm) above top of appliance
- Nozzle Position:** 2 in. (5.1 cm) from inside edge of fry vat
- Nozzle Aiming Point:** Along centerline of fry vat

Note: Figure 89 shows maximum size fryer (Model 1000 D/H). Smaller size fryers (Models 150 D/H, 270 D/H, and 600 D/H) can be protected with less nozzles but nozzle spacings, height requirements, and positions, must be maintained as shown in Figure 89.

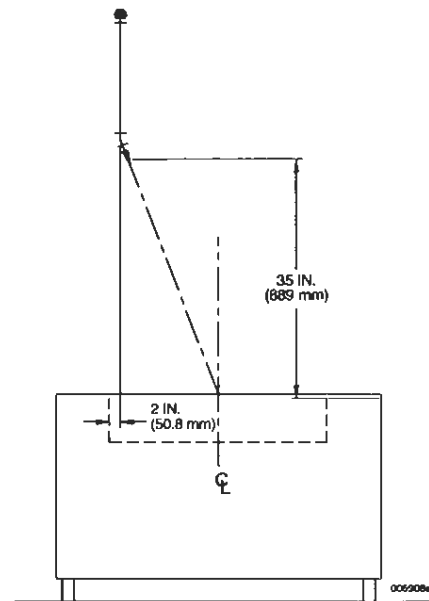
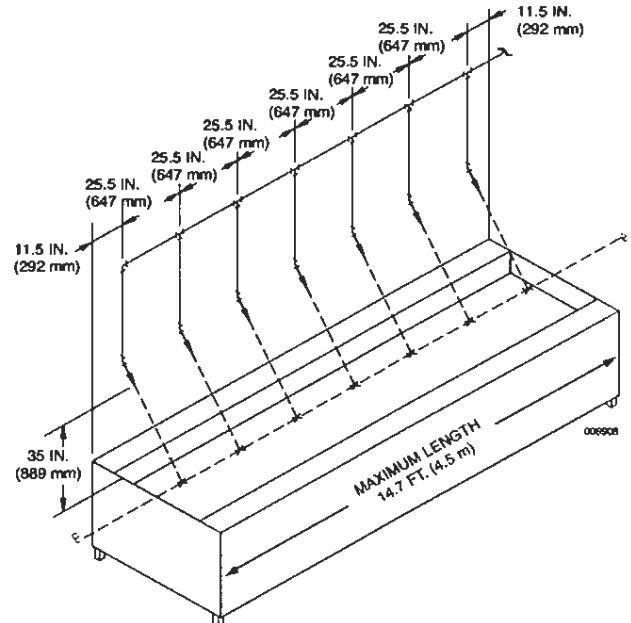

FIGURE 74

NOTES:

SPECIFIC APPLICATION BY MODEL (Continued)

**DUKE Chain Broiler – Model FBB-High Proximity
 DUKE Chain Broiler With or Without Catalyst View:**

- Nozzle Quantity/Type: (1) One 2W nozzle, Part No. 419337
- Nozzle Height: 20 in. (508 mm) above top of appliance

- Nozzle Location: Centered 6 1/2 in. (165 mm) back from front feed edge of appliance. Nozzle must be oriented to spray onto impedance plate.
- Nozzle Aiming Point: Aimed at center of impedance plate

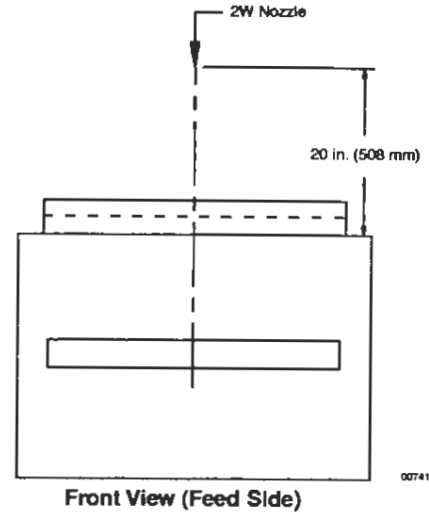
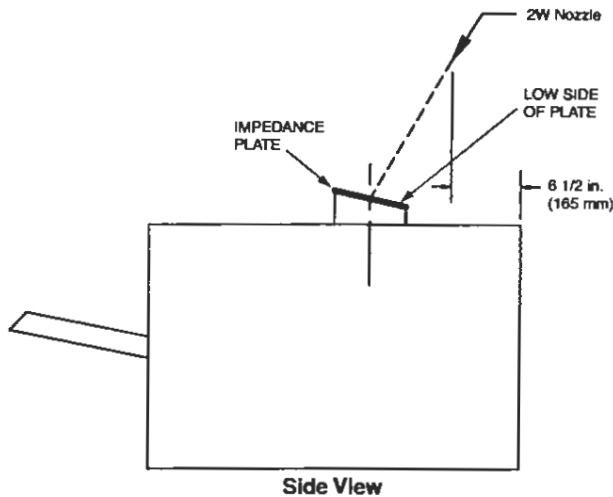

007414
FIGURE 75

DUKE Chain Broiler – Model FBB – Low Proximity

DUKE Chain Broiler With or Without Catalyst View

Exhaust Deflector Size – 6.25 in. (15.9 cm) x 26.75 in. (67.9 cm):

- Nozzle Quantity/Type: (2) Two 245 nozzles, Part No. 419340.
- Nozzle Height: 8 in. to 15 in. (20.3 cm to 38.1 cm) above top of appliance.

- Nozzle Location: 6.5 in. (16.5 cm) from front or back edge of hazard
 First nozzle positioned 17.25 in. (43.8 cm) from right side of broiler (facing broiler)
 Second nozzle positioned 15 in. (38.1 cm) from first nozzle
 Nozzle must be oriented to spray onto impedance plate.

- Nozzle Aiming Point: Aimed at center of impedance plate
- Note:** If the deflector or flue gas diverter is rotated 180 degrees, the nozzles must also rotate to discharge into the opening.

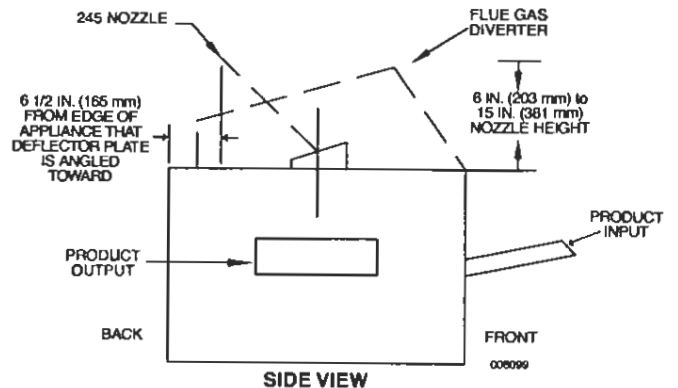
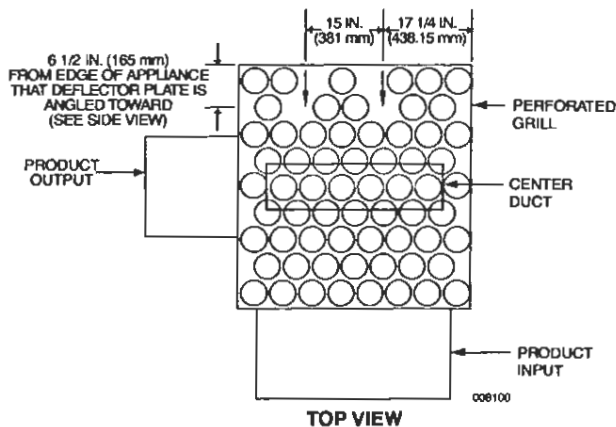

FIGURE 76

► SPECIFIC APPLICATION BY MODEL (Continued)

DUKE Electric Broiler – Model FBB – High Proximity

DUKE Electric Broiler with or without Catalyst View

Nozzle Quantity/Type: (2) Two 1N nozzles

Nozzle Height: 18 in. (45.7 cm)

Nozzle Location: 6.5 in. (16.5 cm) from edge of appliance that deflector plate is angled toward

First nozzle positioned 5 in. (12.7 cm) to left of opening centerline

Second nozzle positioned 5 in. (12.7 cm) to right of opening centerline

See Figure 77

Nozzle Aiming Point: Aimed at center of opening

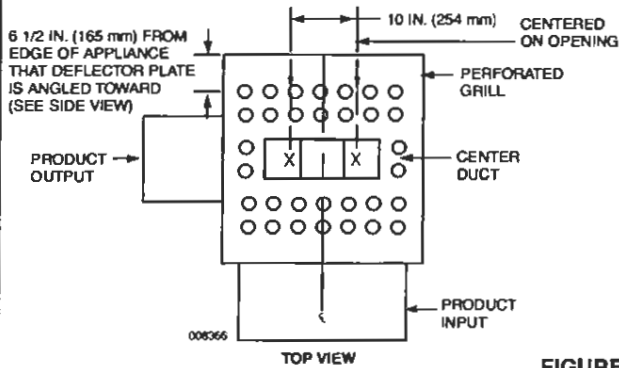
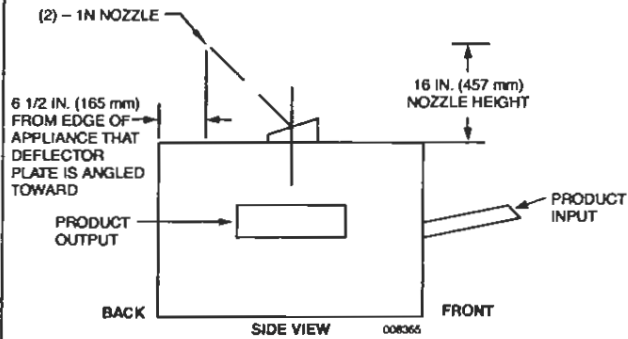

FIGURE 77

► DUKE Electric Broiler – Model FBB – High Proximity

DUKE Electric Broiler without Catalyst View

Nozzle Quantity/Type: (1) One 2W nozzle

Nozzle Height: 20 in. (50.8 cm)

Nozzle Location: 6.5 in. (16.5 cm) from edge of appliance that deflector plate is angled toward

See Figure 78

Nozzle Aiming Point: Aimed at center of opening

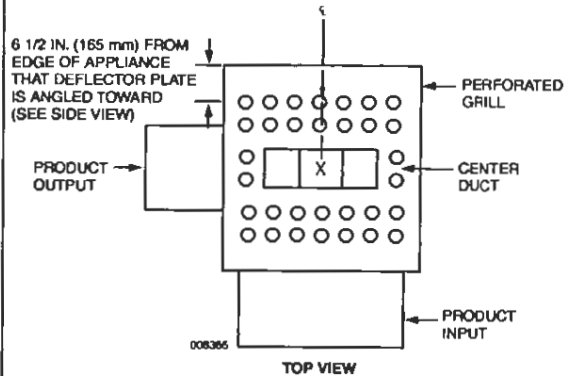
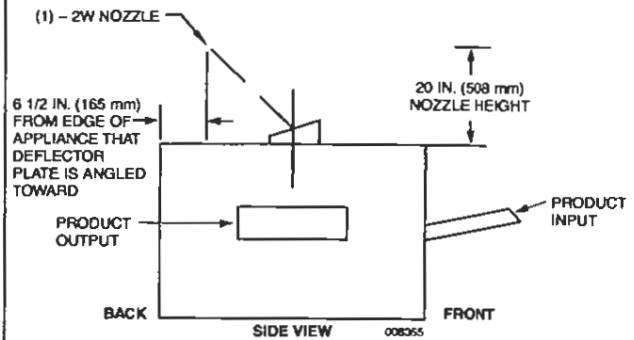

FIGURE 78

SPECIFIC APPLICATION BY MODEL (Continued)

**DUKE Electric Broiler – Model FBB – Low Proximity
 DUKE Electric Broiler with or without Catalyst View**

Nozzle Quantity/Type: (2) Two 245 nozzles

Nozzle Height: 8 in. (20.3 cm) to 15 in. (38.1 cm)

Nozzle Location: 6.5 in. (16.5 cm) from edge of appliance that deflector plate is angled toward

First nozzle positioned 17.5 in. (44.5 cm) from right side of broiler (facing broiler)

Second nozzle positioned 15 in. (38.1 cm) from first nozzle

See Figure 79

Nozzle Aiming Point: Aimed at center of opening

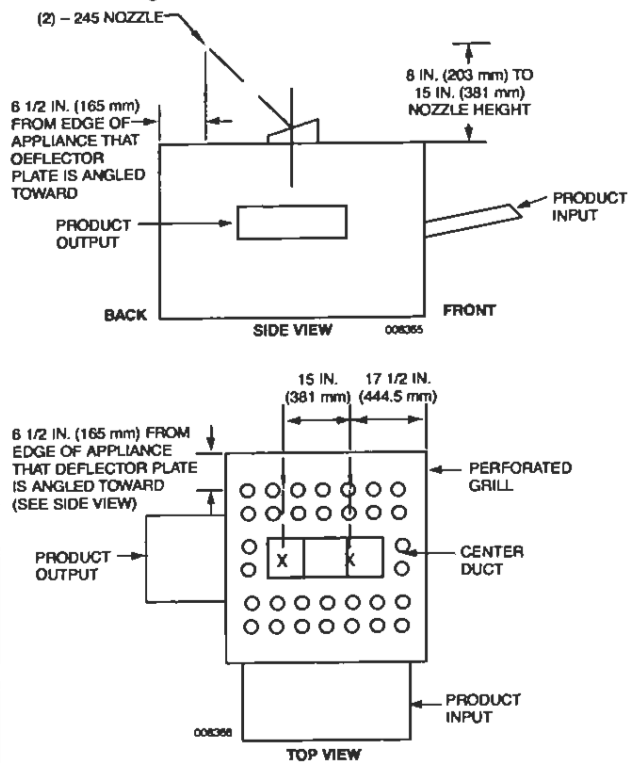

FIGURE 79

SPECIFIC APPLICATION BY MODEL (Continued)

Nieco Broiler Model 940, 962 or 960 With Catalytic Converter Protection

Note: Nieco broilers without catalytic converters use standard chain broiler protection options.

Certain models of the Nieco broiler (Models 940, 962, and 960) are equipped with a catalytic converter to comply with new clean air laws. Because of the converter, it is necessary to protect these broilers in a special way. The guidelines for protecting these broilers are as follows:

- The maximum internal broiling area is 29 in. x 23.5 in. (74 cm x 60 cm).
- An R-102 3-gallon system with a maximum of 6 flow numbers, must be used for protection of each broiler, including plenum and duct.
- Each individual broiler must be protected with a minimum of (2) two, 1N nozzles, Part No. 419335. The nozzles must be located as shown in Figure 80.
- The broiler must be fitted with two 1 in. (2.5 cm) high agent barriers on the angled surface of the broiler. If these have not been completed by the equipment supplier, they must be added in the field.

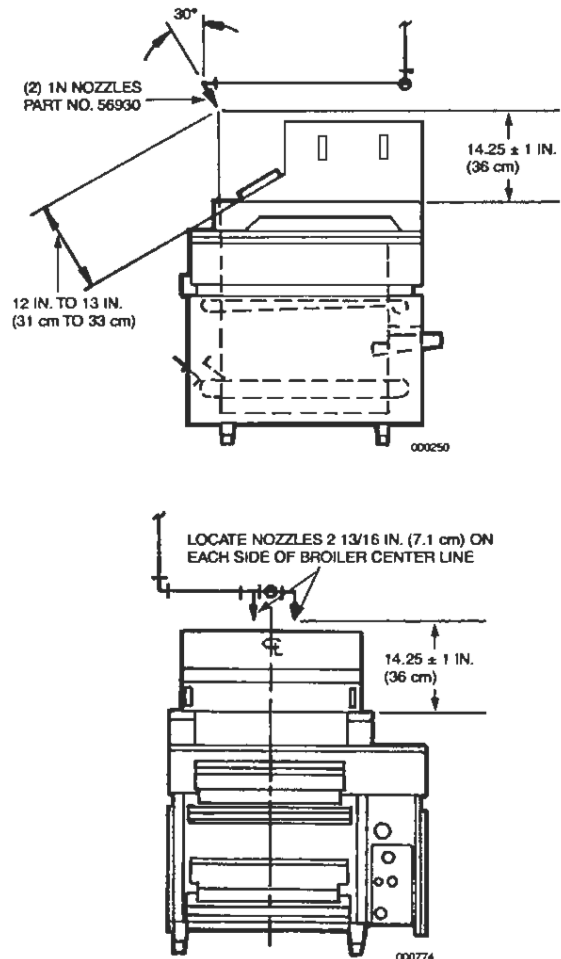

FIGURE 80

SECTION IV – SYSTEM DESIGN

SPECIFIC APPLICATION BY MODEL (Continued)

- ▶ **Nieco Broiler – Model 950, 960, 980, 1424**
 - **Nozzle Quantity/Type:** (1) One 2W nozzle, Part No. 419337.
 - **Nozzle Height:** 20 in. (508 mm) above top of appliance. See Figure 81a.
 - **Nozzle Location:** 6 1/2 in. (165 mm) back from front edge of appliance. See Figure 81a.
 - **Nozzle Aiming Point:** Aimed at center of opening. See Figure 81a.
- ▶ **Nieco Broiler – Model 950, 960, 980, 1424 (with Catalytic Converter)**
 - **Nozzle Quantity/Type:** (2) Two 2W nozzles, Part No. 419337.
 - **Nozzle Height:** 20 in. (508 mm) above top of appliance. See Figure 81b.
 - **Nozzle Location:** 6 1/2 in. (165 mm) back from front edge of appliance. See Figure 81b.
 - **Nozzle Aiming Point:** Aimed at center of opening. See Figure 81b – Side View.
 - **Nozzle Aiming Point:** Aimed at point 3 in. (76 mm) each side of center. See Figure 81b – Front View.

Nieco Broiler – Model 9015 (With or Without Catalytic Converter)

- **Nozzle Quantity/Type:** (2) Two 2W nozzles, Part No. 419337.
- **Nozzle Height:** 20 in. (508 mm) above top of appliance. See Figure 82.
- **Nozzle Location for Large Chamber:** 6 1/2 in. (165 mm) back from front edge of appliance. See Figure 82.
- **Nozzle Location for Small Chamber:** Nozzle to be located 6 1/2 in. (165 mm) back from front edge of appliance and 12 in. (305 mm) over from large chamber nozzle.
- **Nozzle Aiming Point for Large Chamber:** Aimed at center of opening. See Figure 82.
- **Nozzle Aiming Point for Small Chamber:** Nozzle to be aimed 12 in. (305 mm) over from large chamber nozzle aiming point.

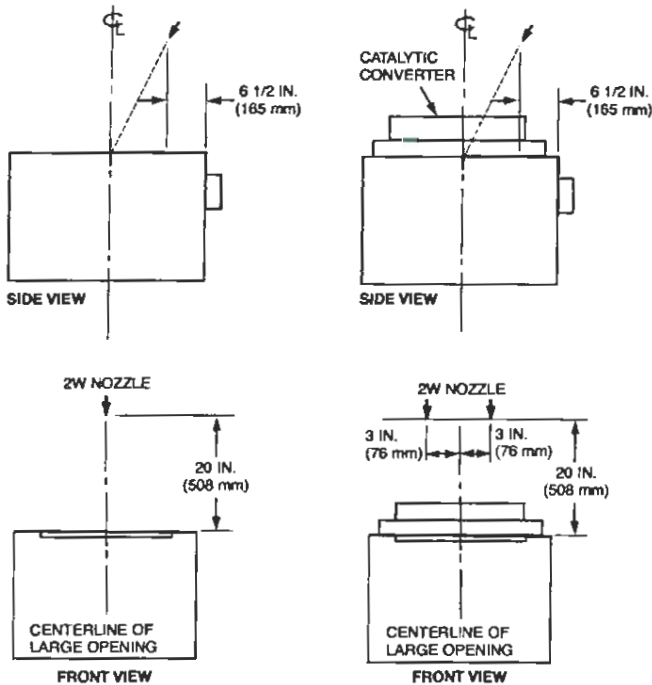

FIGURE 81a
006486

FIGURE 81b
007034

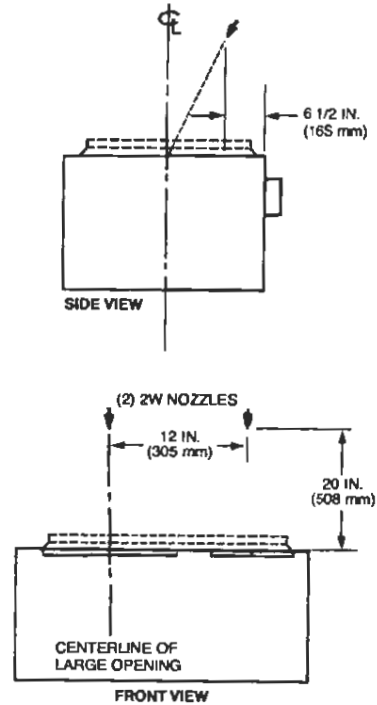

FIGURE 82
007010

SPECIFIC APPLICATION BY MODEL (Continued)

Nieco Broiler – Model 9025 (With or Without Catalytic Converter)

- **Nozzle Quantity/Type:** (2) Two 2W nozzles, Part No. 419337.
- **Nozzle Height:** 20 1/2 in. (521 mm) above top of appliance. See Figure 83.
- **Nozzle Location:** 6 1/2 in. (165 mm) back from front edge of appliance. See Figure 83.
- **Nozzle Aiming Point:** Aimed at center of each opening. See Figure 83.

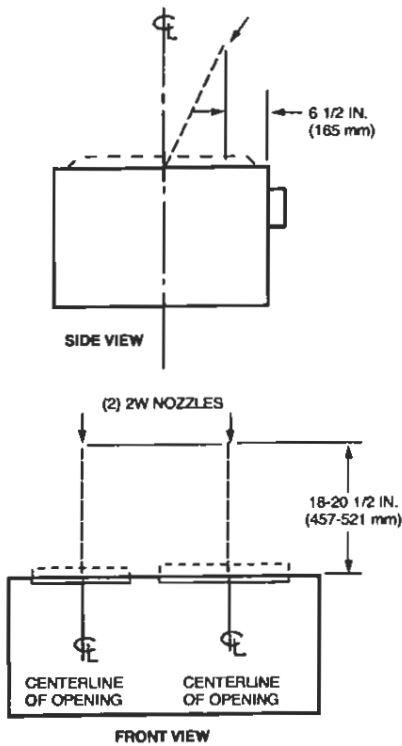

FIGURE 83
004355

Nieco Broiler – Model MPB94 and MPB84 – High Proximity (With/Without Catalytic Converters)

- **Nozzle Quantity/Type:** (1) One 2W nozzle, Part No. 419337.
- **Nozzle Height:** 20 in. (508 mm) above top of converter. See Figure 84.
- **Nozzle Location:** Centered 6 1/2 in. (165 mm) back from any edge of the appliance. See Figure 84.
- **Nozzle Aiming Point:** Aimed at center of opening. See Figure 84.

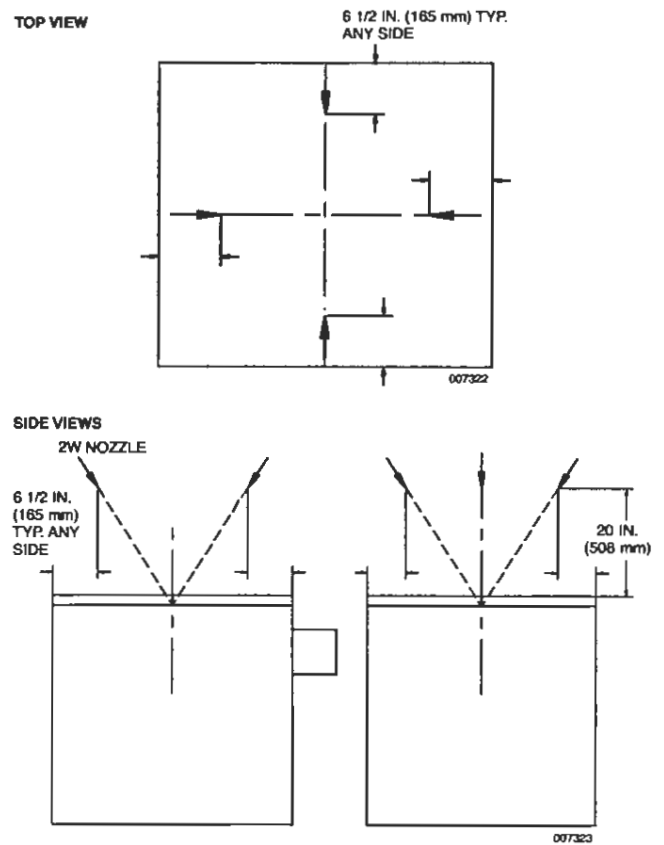

FIGURE 84
006487

SPECIFIC APPLICATION BY MODEL (Continued)

Nieco Broiler – Model MPB94 – Low Proximity (With or Without Catalytic Converter)

Nozzle Quantity/Type: (2) Two 245 nozzles, Part No. 419340.

Nozzle Height: 8 in. to 15 in. (20.3 to 38.1 cm) measured from top of converter

Nozzle Location: 6.5 in. (16.5 cm) from front or back edge of hazard.

First nozzle positioned 7.5 in. (19.1 cm) to the right from center of hazard.

Second nozzle positioned 7.5 in. (19.1 cm) to the left from center of hazard.

See Figure 85.

Nozzle Aiming Point: Aimed at opening on respective center lines

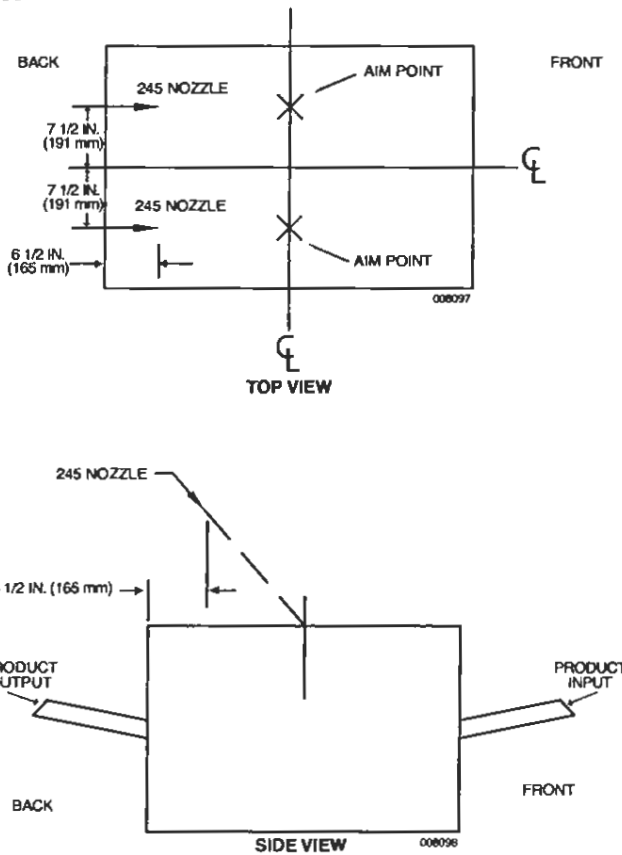

FIGURE 85

Nieco Broiler – Model MPB84 – Low Proximity (With Catalytic Converter)

Nozzle Quantity/Type: (2) Two 245 nozzles, Part No. 419340.

Nozzle Height: 8 in. to 15 in. (20.3 to 38.1 cm) measured from top of converter

Nozzle Location: 6.5 in. (16.5 cm) from front or back edge of hazard.

First nozzle positioned 7.5 in. (19.1 cm) to the right from center of hazard.

Second nozzle positioned 7.5 in. (19.1 cm) to the left from center of hazard.

See Figure 86.

Nozzle Aiming Point: Aimed at opening on respective center lines

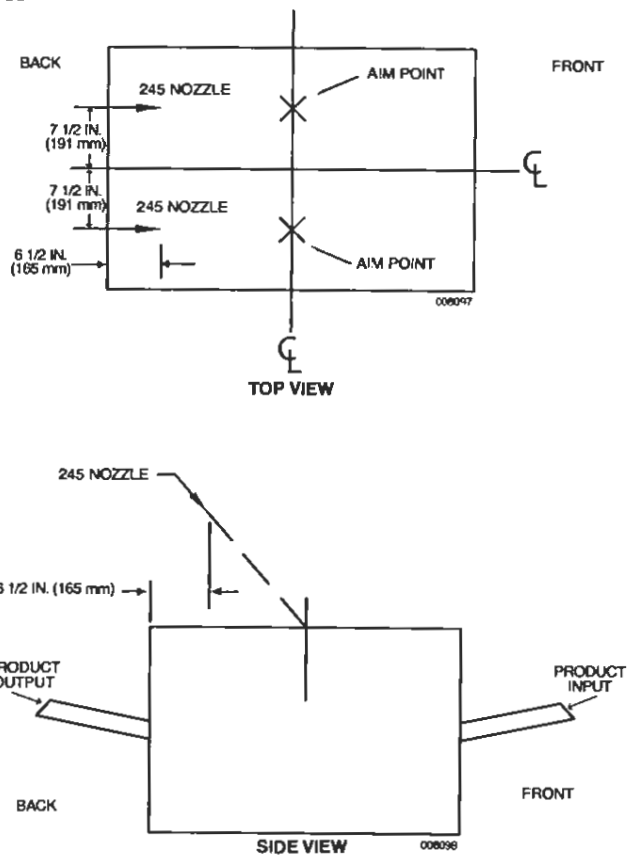

FIGURE 86

SPECIFIC APPLICATION BY MODEL (Continued)

**Nieco Broiler – Model MPB84 and MPB94 – High Proximity
 (With Perforated Cap OR with Catalytic Converter and
 Chimney)**

Nozzle Quantity/Type: (2) Two 1N nozzles

Nozzle Height: 18 in. (45.7 cm) to 20 in. (50.8 cm)

Nozzle Location: 6.5 in. (16.5 cm) from front or back edge of hazard

First nozzle positioned 5 in. (12.7 cm) to left of opening centerline

Second nozzle positioned 5 in. (12.7 cm) to right of opening centerline

See Figure 87

Nozzle Aiming Point: Aimed at center of opening

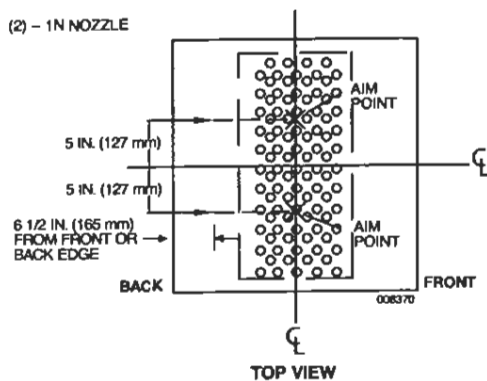
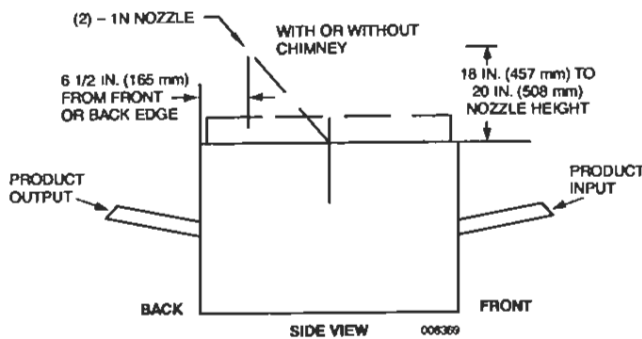

FIGURE 87

**Nieco Broiler – Model MPB84 and MPB94 – Low Proximity
 (With Perforated Cap OR with Catalytic Converter and
 Chimney)**

Nozzle Quantity/Type: (2) Two 245 nozzles

Nozzle Height: 8 in. (20.3 cm) to 15 in. (38.1 cm)

Nozzle Location: 6.5 (16.5 cm) from front or back edge of hazard

First nozzle positioned 7.5 in. (19.1 cm) to the right of hazard centerline

Second nozzle positioned 7.5 in. (19.1 cm) to the left of hazard centerline

See Figure 88

Nozzle Aiming Point: Aimed at center of opening

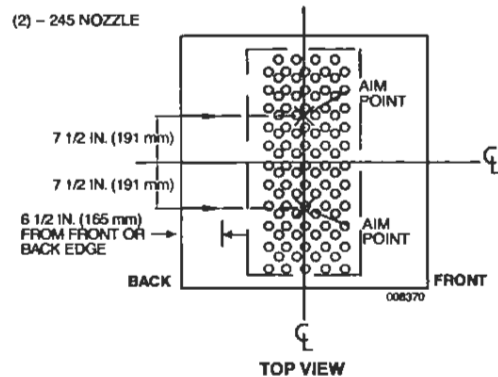
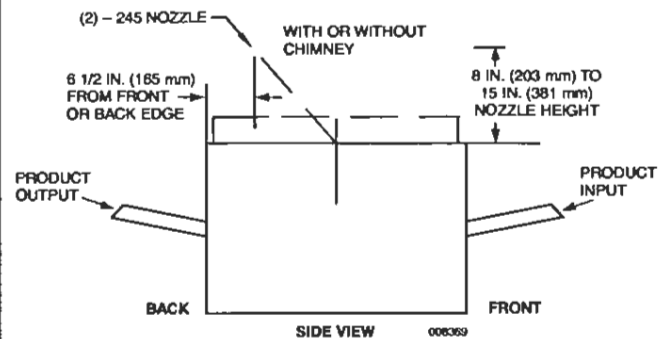

FIGURE 88

SECTION IV – SYSTEM DESIGN

SPECIFIC APPLICATION BY MODEL (Continued)

Marshall Air – Model 2001BK Multi-Chamber Broiler

- **Nozzle Quantity/Type:** (2) Two 1W nozzles, Part No. 419347.
 - **Nozzle Location:** Front nozzle tip must be located 14 in. directly above the appliance, aligned with the front face and centerline of the catalytic converter. The aim point is 4 in. forward of the front edge of the converter on the centerline.
- The rear nozzle tip is a mirror image of the front. The rear nozzle is located 14 in. vertically above the appliance, aligned with the "rear" face and centerline of the catalytic converter. The aim point is 4 in. behind the "rear" edge of the converter on the centerline. See Figure 89.
- **System Limitation:** Maximum of 5 flows for a 3.0 gallon system: Remaining flow points available may be used to protect other hazards.

CENTERED ON CONVERTER

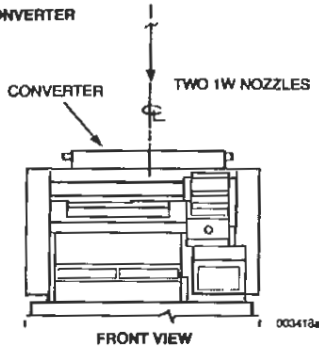

NOZZLE ALIGNED WITH FRONT OF CONVERTER

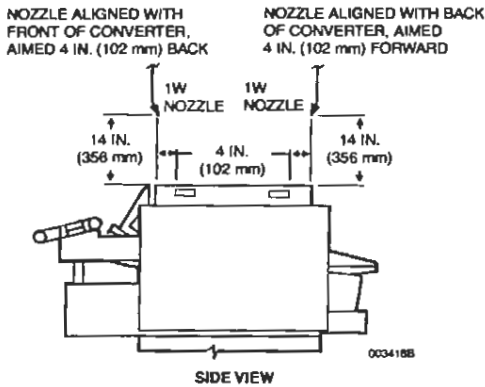

FIGURE 89

Marshall Air Electric Broiler – Model FR14B AutoBroil

- **Nozzle Quantity/Type:** One 260 Nozzle (Part No. 419341)
- **Nozzle Height:** 15 – 20 in. (38.1 – 50.8 cm) above the top of the broiler
- **Nozzle Location:** The nozzle must be centered above the front edge of the broiler
- **Nozzle Aiming Point:** Aimed at the center of the exhaust opening of the broiler. See Figure 90.

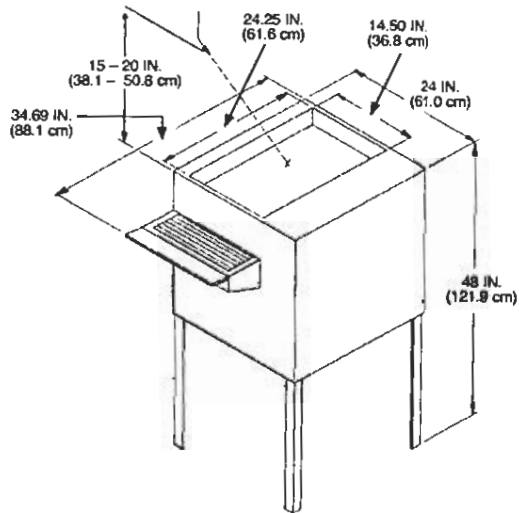
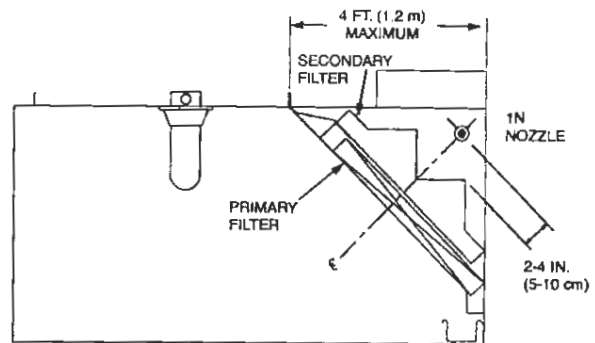

FIGURE 90
006737

Grease Grabber-80™ Two Stage Filtration System

The Grease Grabber-80 Two Stage Filtration System consists of two components: The primary filter (The Grease-X Tractor) and the secondary filter (The Grease Grabber-80).

The protection required for this application is the same as the standard plenum/filter protection: One (1) 1N Nozzle, Part No. 419335, protecting 10 (3.1 m) linear feet of plenum length by 4 ft (1.2 m) of plenum chamber depth (width), positioned 2-4 in. (5-10 cm) from peak of secondary filter. See Figure 91.



NOTE: TWO NOZZLES MUST BE UTILIZED FOR V-BANK FILTER ARRANGEMENT.

FIGURE 91
006626

OVERLAPPING NOZZLE COVERAGE

Overlapping Coverage – Option 1

For each group of protected appliances under a common hood(s), the overlapping nozzles must be located from right to left so that each end nozzle is located a maximum of 6 in. (15.2 cm) inside the outside edge of the cooking hazard of each end appliance, and the inside overlapping nozzles must be located between the two end nozzles at a maximum spacing of 12 in. (30.5 cm).

Hazard Zone

The hazard zone is defined as a theoretical, flat and level, rectangular surface, that includes all of the cooking hazards of the protected appliances under a common hood(s). The purpose of the hazard zone is to provide a means of locating the appliances and the overlapping nozzles, as well as aiming the overlapping nozzles. The hazard zone measures 28 in. (71.1 cm) deep by the length of the cooking hazard(s). The centerline of the hazard zone must bisect the 28 in. (71.1 cm) depth (from front to back) and run from right-to-left for the full width of the hazard zone.

Overlapping Nozzle Appliance Protection

Overlapping Nozzle Appliance Protection is defined as protection of cooking appliances by nozzles spaced uniformly at uniform elevations under a common hood(s). Overlapping protection of appliances is continuous for the full length of the hood or divided when group(s) of protected appliances are separated by counters or appliances not requiring protection.

Full hood continuous protection is defined as overlapping nozzle appliance protection that covers the appliance line-up located under the total hood length. All appliances requiring protection are the appliances under the hood that can be an ignition source of grease in the hood, grease removal device or the duct.

Group protection is defined as overlapping nozzle appliance protection that protects individual hazard zones located under a common hood. These “groups” of appliances may be separated by appliances not requiring protection, such as steam equipment or work tables, or by dedicated appliance protection, such as salamander broilers.

See Figure 91d (full hood continuous protection) and Figure 91e (multiple group protection).

Dedicated Nozzle Appliance Protection

Appliance protection using dedicated nozzle coverage is defined as protection of cooking appliances with enclosed cooking hazards, such as upright broilers, which cannot be protected with overlapping nozzles and therefore must be protected with nozzles dedicated to the appliance.

General Design Limitations

- Maximum depth of zone is 28 in. (71.1 cm).
- The 245 nozzle, Part No. 419340, is the only approved nozzle for overlapping (zone) protection.
- Nozzle must be located 0 in. to 6 in. (0 cm to 15.2 cm) forward of zone centerline, aimed back at the zone centerline.
- Nozzles must be spaced a maximum of 6 in. (15.2 cm) from each end of hazard and then a maximum of 12 in. (30.5 cm) on center for the remaining overlapping nozzles until the complete hazard is covered.

- For appliance hazard surfaces with listed protection exceeding the standard hazard zone of 28 in. (71.1 cm) in depth, the hazard surface(s) must be aligned with the back edge of the hazard zone, with the front edge overhanging the front edge of the zone. See Appliance Chart, Table 1.
- For appliance hazard surfaces that exceed the listed protection sizes, multiple zones must be utilized. Align entire hazard surface area within the multiple zones.
- All hood, duct, individual appliance, and piping limitations are as specified in the R-102 Design, Installation, Recharge and Maintenance Manual, Part No. 418087.
- All appliance protection currently listed in the R-102 Design Manual, Part No. 418087, is also approved protection. Zone protection can be considered optional protection.

TABLE 1
Overlapping Nozzle Coverage (Zone Protection)

Appliance Type	Maximum Cooking Hazard
Fryer	34 in. (86.4 cm) Deep x 5.8 ft ² (0.5 m ²)
Griddle	30 in. (76.2 cm) Deep x Unlimited Length
Range	28 in. (71.1 cm) Deep x Unlimited Length
Wok, Maximum	30 in. (76.2 cm) Diameter x 8 in. (20.3 cm) Deep
Wok, Minimum	11 in. (27.9 cm) Diameter x 3 in. (7.6 cm) Deep
Braising Pan/Tilt Skillet*	34 in. (86.4 cm) Deep x Unlimited Length
Lava Rock Char-Broiler	32 in. (81.3 cm) Deep x Unlimited Length
Charcoal Broiler	32 in. (81.3 cm) Deep x Unlimited Length (4 in. (10.2 cm) Maximum Fuel Depth)
Mesquite Wood Broiler	32 in. (81.3 cm) Deep x Unlimited Length (12 in. (30.5 cm) Maximum Fuel Depth)
Gas Radiant Char-Broiler	36 in. (91.4 cm) Deep x Unlimited Length
Electric Char-Broiler	34 in. (86.4 cm) Deep x 20 in. (50.8 cm)

* See Figure 91a for nozzle location

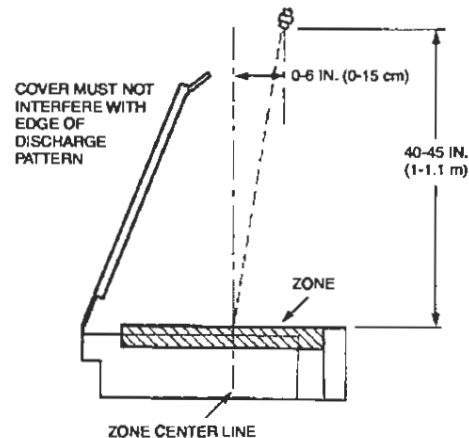

FIGURE 91a
 008927

OVERLAPPING NOZZLE COVERAGE (Continued)

Overlapping Appliance Nozzle and Hazard Zone Locations

1. All overlapping appliance nozzles must be the “245” nozzle, Part No. 419340, and must be located under a common hood at the same height above the hazard zone, in a straight line from right to left and aimed at the centerline of the hazard zone. The overlapping nozzle is used for both continuous overlapping and multiple group overlapping protection.
2. The hazard zone must be positioned (located) so that all appliance hazard surfaces are within the zone. For appliance hazard surfaces with listed protection exceeding the standard hazard zone size of 28 in. (71 cm) in depth (see Table 1), the hazard surface(s) must be aligned with the back edge of the hazard zone, with the front edge overhanging the front of the zone.
3. The overlapping appliance nozzles must be located 40 in. to 45 in. (1 m to 1.1 m) above the top surface of the protected appliances. See Figure 91c.

Exception No. 1: Nozzle dimensions for wok protection are measured to bottom of wok. Exception No. 2: When using overlapping appliance nozzles in areas where there is a back shelf, the nozzle cannot be positioned in the shaded area as shown in Figure 91b.

Also, back shelf must not extend more than 11 in. (27.9 cm) over the hazard zone and cannot be less than 20 in. (50.8 cm) above the hazard zone. See Figure 91b.

4. The overlapping appliance nozzles must be located 0 in. to 6 in. (0 cm to 15.2 cm) forward of the centerline or aimline of the selected hazard zone. See Figure 91c.

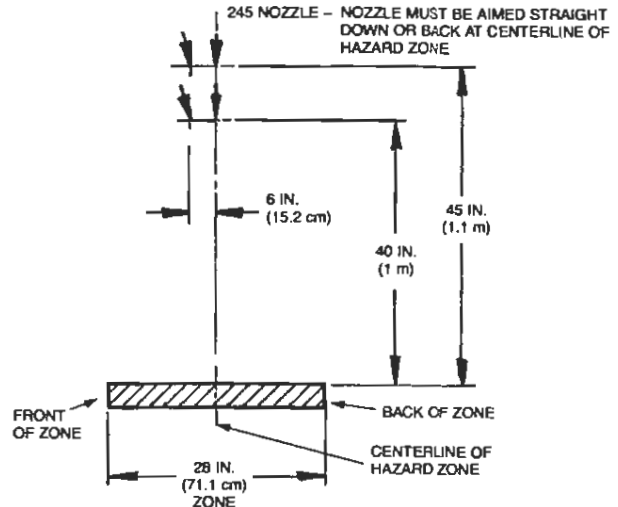

FIGURE 91c
009915

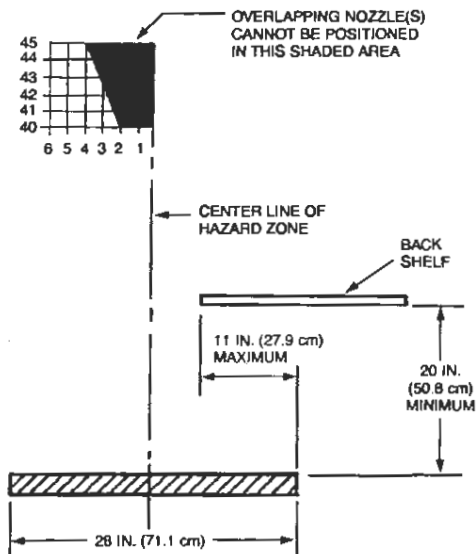

FIGURE 91b
006914

OVERLAPPING NOZZLE COVERAGE (Continued)

Overlapping Appliance Nozzle and Hazard Zone Locations – Group Protection

1. For each group of protected appliances under a common hood(s), the overlapping nozzles must be located from right to left so that each end nozzle is located a maximum of 6 in. (15.2 cm) inside the outside edge of the cooking hazard of each end appliance, and the inside overlapping nozzles must be located between the two end nozzles at a maximum spacing of 12 in. (30.5 cm). See Figures 91d and 91e.

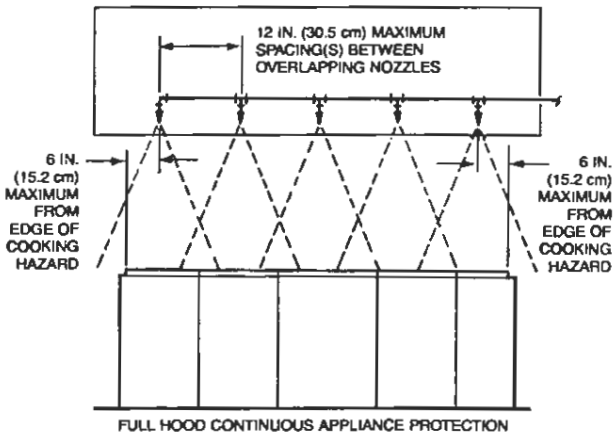

FIGURE 91d
001710

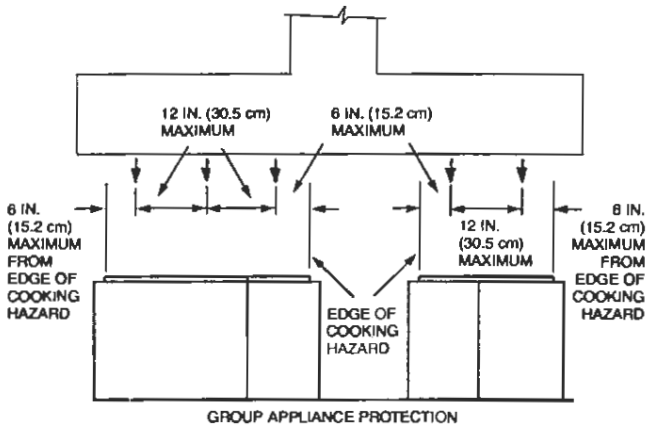

FIGURE 91e
001720

2. When obstructions are located adjacent to appliance(s) protected by overlapping nozzles, the overlapping appliance nozzle spacing must start with the appliance(s) adjacent to the obstruction. See Figure 91f.

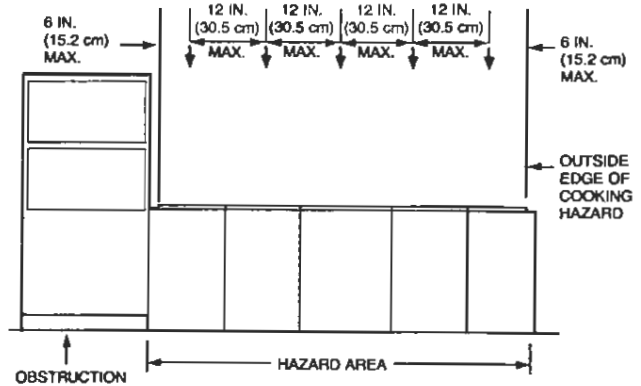

FIGURE 91f
001713

3. When an appliance requires dedicated protection with a protected area intended for overlapping appliance nozzle protection, the group protection option will be required for appliances on either side of the appliances using dedicated protection. Group protection using overlapping appliance nozzles must begin with the protected appliance(s) adjacent to the dedicated appliance protected. An overlapping appliance nozzle(s) must be positioned within 6 in. (15.2 cm) of the edge(s) of the appliance hazard surface area(s) adjacent to the dedicated nozzle protection. See Figure 91g.

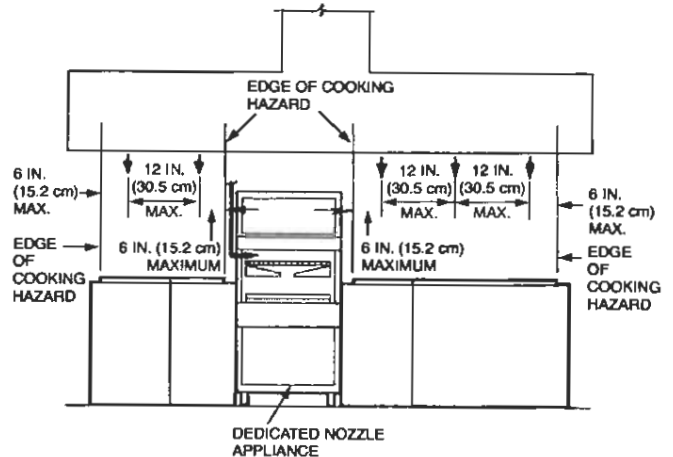

FIGURE 91g
001756

SECTION IV – SYSTEM DESIGN

OVERLAPPING NOZZLE COVERAGE (Continued)

Overlapping Appliance Nozzle and Hazard Zone Locations – Group Protection (Continued)

- 4. On protected appliances, all hazard surfaces located in a group must be within 40-45 in. (102-114 cm) from the nozzle(s). Once that dimension is exceeded, a new group must be started. See Figure 91h.

Note: The supply pipe feeding nozzle groups is to be at the same elevation. Adjust height for each group only by varying lengths of nozzle drops.

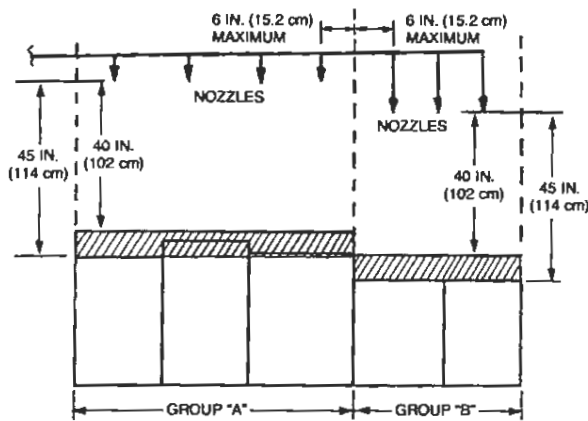

FIGURE 91h
006017

Detection Requirements For Overlapping Appliance Protection

When utilizing overlapping appliance protection, fusible link detectors must be installed on a maximum of 2 ft (0.61 m) centers, starting with detectors located in (under) the duct opening(s).

Starting from the detector under the duct opening, add detectors on 2 ft (0.61 m) maximum spacing until the complete length of the plenum area is covered, from one end to the other. The location of the last detector on each end of the plenum must not exceed 2 ft (0.61 m) from end of plenum.

Note: Standard detector coverage, as specified in "Design Section," is acceptable when utilizing dedicated nozzle coverages.

OVERLAPPING NOZZLE COVERAGE (Continued)

▶ Overlapping Coverage – Option 2

For each group of protected appliances under a common hood(s), the overlapping nozzles must be located from right to left so that each end nozzle is located a maximum of 11.5 in. (29.2 cm) inside the outside edge of the cooking hazard of each end appliance, and the inside overlapping nozzles must be located between the two end nozzles at a maximum spacing of 25.5 in. (64.8 cm).

Hazard Zone

The hazard zone is defined as a theoretical, flat and level, rectangular surface, that includes all of the cooking hazards of the protected appliances under a common hood(s). The purpose of the hazard zone is to provide a means of locating the appliances and the overlapping nozzles, as well as aiming the overlapping nozzles. The hazard zone measures 28 in. (711 mm) deep by the length of the cooking hazard(s). The centerline of the hazard zone must bisect the 28 in. (711 mm) depth (from front to back) and run from right-to-left for the full width of the hazard zone.

Overlapping Nozzle Appliance Protection

Overlapping Nozzle Appliance Protection is defined as protection of cooking appliances by nozzles spaced uniformly at uniform elevations under a common hood(s). Overlapping protection of appliances is continuous for the full length of the hood or divided when group(s) of protected appliances are separated by counters or appliances not requiring protection.

Full hood continuous protection is defined as overlapping nozzle appliance protection that covers the appliance line-up located under the total hood length. All appliances requiring protection are the appliances under the hood that can be an ignition source of grease in the hood, grease removal device or the duct.

Group protection is defined as overlapping nozzle appliance protection that protects individual hazard zones located under a common hood. These “groups” of appliances may be separated by appliances not requiring protection, such as steam equipment or work tables, or by dedicated appliance protection, such as salamander broilers.

- ▶ See Figure 95 (full hood continuous protection) and Figure 96 (multiple group protection).

Dedicated Nozzle Appliance Protection

Appliance protection using dedicated nozzle coverage is defined as protection of cooking appliances with enclosed cooking hazards, such as upright broilers, which cannot be protected with overlapping nozzles and therefore must be protected with nozzles dedicated to the appliance.

General Design Limitations

- If overlapping appliance protection is mixed with dedicated appliance protection on the same pipe system, THE OVERLAPPING APPLIANCE PROTECTION PIPING REQUIREMENTS MUST BE FOLLOWED.
- ▶ • Overlapping protection requires the use of 3.0 gal (11.4 L) tank(s) and a maximum of six (6) flows per tank.
- In installations using tanks only intended for overlapping protection, a single Double Tank nitrogen expellant gas cartridge can be utilized with up to three (3) 3.0 gal (11.4 L) tanks.
- In installations using both overlapping protection and conventional non-overlapping protection (ex. hood/duct or dedicated appliance protection), a single Double Tank nitrogen expellant gas cartridge can be utilized with up to three (3) 3.0 gal (11.4 L) tanks, as long as none of the 3.0 gal (11.4 L) tanks exceed a total flow output of more than six (6) flows.
- If more than six (6) flows will be used in a conventional non-overlapping tank, it cannot share the same cartridge as tanks intended for overlapping protection. In this case, an additional Regulated Actuator Assembly with another expellant gas cartridge will be required.
- The 245 nozzle, Part No. 419340, must be used for “end of zone” protection.
- The 260 nozzle, Part No. 419341, must be used for zone protection.
- ▶ • Maximum depth of zone is 28 in. (71.1 cm).
- Refer to overlapping system piping requirements listed in Table 2.
- ▶ • Nozzle must be located 0 in. to 12 in. (0 cm to 30.5 cm) forward of zone centerline, aimed back at the zone centerline.
- ▶ • Nozzles must be spaced a maximum of 11.5 in. (29.2 cm) from each end of hazard and then a maximum of 25.5 in. (64.8 cm) on center for the remaining overlapping nozzles until the complete hazard is covered.
- For appliance hazard surfaces with listed protection exceeding the standard hazard zone of 28 in. (71 cm) in depth, the hazard surface(s) must be aligned with the back edge of the hazard zone, with the front edge overhanging the front edge of the zone. See Appliance Chart, Table 1.
- For appliance hazard surfaces that exceed the listed protection sizes, multiple zones must be utilized. Align entire hazard surface area within the multiple zones.
- All hood, duct, and individual appliance protection are as specified in the R-102 Design, Installation, Recharge and Maintenance Manual, Part No. 418087.
- All appliance protection currently listed in the R-102 Design Manual, Part No. 418087, is also approved protection. Zone protection can be considered optional protection.

SECTION IV – SYSTEM DESIGN

OVERLAPPING NOZZLE COVERAGE (Continued)

TABLE 1
Overlapping Nozzle Coverage (Zone Protection)

Appliance Type	Maximum Cooking Hazard
Fryer	34 in. (86.4 cm) Deep x 5.8 ft ² (0.5 m ²)
Griddle	30 in. (76.2 cm) Deep x Unlimited Length
Range	30 in. (76.2 cm) Deep x Unlimited Length
Wok, Maximum	30 in. (76.2 cm) Diameter x 8 in. (20.3 cm) Deep
Wok, Minimum	11 in. (27.9 cm) Diameter x 3 in. (7.6 cm) Deep
Braising Pan/Tilt Skillet*	34 in. (86.4 cm) Deep x Unlimited Length
Lava Rock Char-Broiler (see Note 1)	26 in. (66.0 cm) Deep x Unlimited Length
Charcoal Broiler	30 in. (76.2 cm) Deep x Unlimited Length (4 in. (10.2 cm) Maximum Fuel Depth)
Mesquite Wood Broiler	30 in. (76.2 cm) Deep x Unlimited Length (6 in. (15.2 cm) Maximum Fuel Depth)
Gas Radiant Char-Broiler	36 in. (91.4 cm) Deep x Unlimited Length
Electric Char-Broiler	34 in. (86.4 cm) Deep x Unlimited Length

* See Figure 92 for nozzle location

Note 1: Always try to place Lava Rock Char-Broiler(s) near the center of the zone. When the Lava Rock Char-Broiler is the first or last appliance in the zone, the outside edge of the broiler must not be more than 6 in. (15 cm) outside the end nozzle.

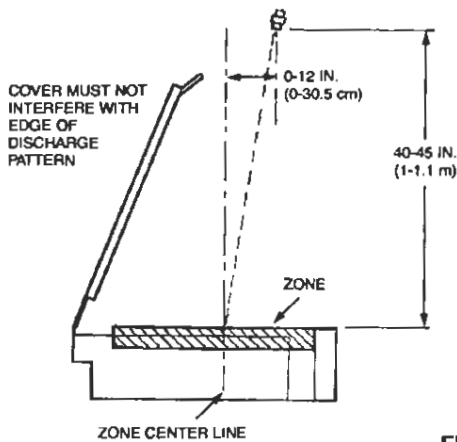

FIGURE 92
006927

Overlapping Appliance Nozzle and Hazard Zone Locations

1. All overlapping appliance nozzles must be the 245 nozzle, Part No. 419340, for "end of zone" protection and the 260 nozzle, Part No. 419341, for zone protection, and must be located under a common hood at the same height above the hazard zone, in a straight line from right to left and aimed at the centerline of the hazard zone. The overlapping nozzle is used for both continuous overlapping and multiple group overlapping protection.
2. The hazard zone must be positioned (located) so that all appliance hazard surfaces are within the zone. For appliance hazard surfaces smaller than the standard hazard zone size, the hazard surface can be located anywhere within the standard hazard zone. For appliance hazard surfaces with listed protection exceeding the standard hazard zone size of 28 in. (71 cm) in depth (see Table 1), the hazard surface(s) must be aligned with the back edge of the hazard zone, with the front edge overhanging the front of the zone.
3. The overlapping appliance nozzles must be located 40 in. to 45 in. (1 m to 1.1 m) above the top surface of the protected appliances. See Figure 94.

Exception No. 1: Nozzle dimensions for wok protection are measured to bottom of wok. Exception No. 2: When using overlapping appliance nozzles in areas where there is a back shelf, the nozzle cannot be positioned in the shaded area as shown in Figure 93.

Also, back shelf must not extend more than 11 in. (27.9 cm) over the hazard zone and cannot be less than 18 in. (45.7 cm) above the hazard zone. See Figure 93.

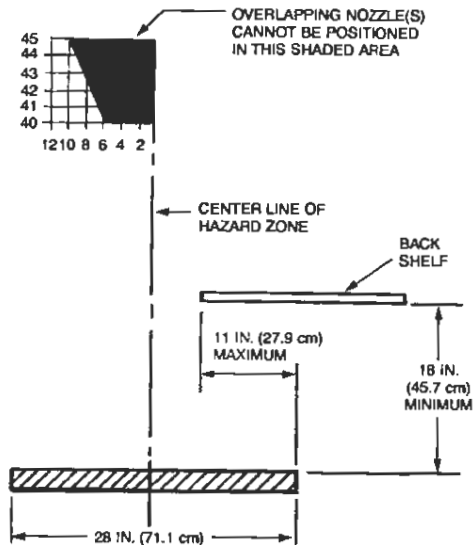

FIGURE 93
006914

OVERLAPPING NOZZLE COVERAGE (Continued)

- 4. The overlapping appliance nozzles must be located 0 in. to 12 in. (0 cm to 30.5 cm) forward of the centerline or airline of the selected hazard zone. See Figure 94.

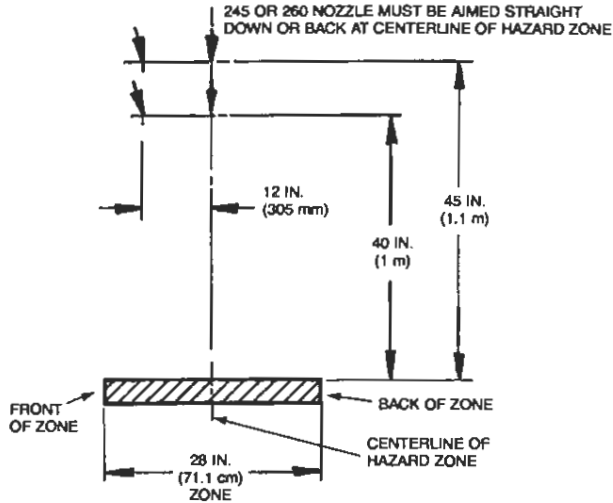

FIGURE 94
007537

Overlapping Appliance Nozzle and Hazard Zone Locations – Group Protection

- 1. For each group of protected appliances under a common hood(s), the overlapping nozzles must be located from right to left so that each end nozzle is located a maximum of 11.5 in. (29.2 cm) inside the outside edge of the cooking hazard of each end appliance, and the inside overlapping nozzles must be located between the two end nozzles at a maximum spacing of 25.5 in. (64.8 cm). See Figures 95 and 96.

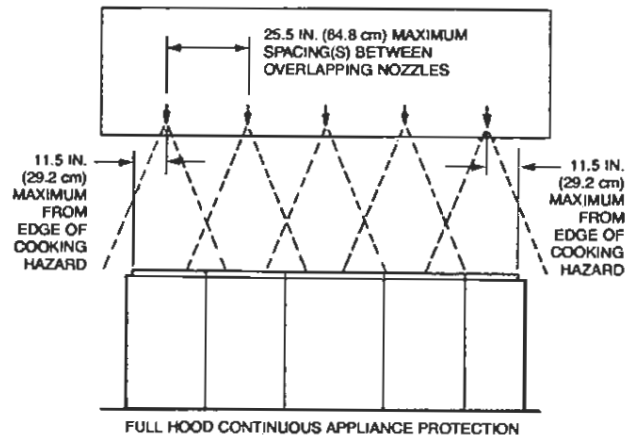

FIGURE 95
007538

Table 2
Overlapping System Piping Limitations

System Size	Total Flow Numbers	Max. 3/8 in. Pipe Length	Max. No. of Elbows	Maximum Elevation Rise	Cartridge Size
3 Gallon (11.4 L)	6	75 ft (22.9 m)	25	10 ft (3.1 m)	LT-30-R
6 Gallon (22.7 L) Manifolder	12	75 ft (22.9 m)	25	10 ft (3.1 m)	Double Tank/ LT-A-101-30*
9 Gallon (34.1 L)	18	75 ft (22.9 m)	25	10 ft (3.1 m)	Double Tank/ LT-A-101-30*

50 ft (15.2 m) maximum pipe from first to last nozzle.

50 ft (15.2 m) maximum pipe after the split on a split system.

*Use with regulated actuator only.

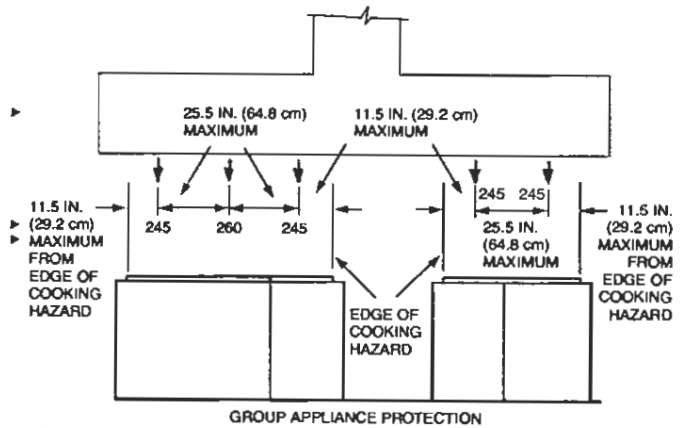

NOTE: On group appliance protection, start and end of EACH zone group must be protected with a 245 nozzle.

FIGURE 96
001720

SECTION IV – SYSTEM DESIGN

OVERLAPPING NOZZLE COVERAGE (Continued)

Overlapping Appliance Nozzle and Hazard Zone Locations – Group Protection (Continued)

- When obstructions are located adjacent to appliance(s) protected by overlapping nozzles, the overlapping appliance nozzle spacing must start with the appliance(s) adjacent to the obstruction. See Figure 97.

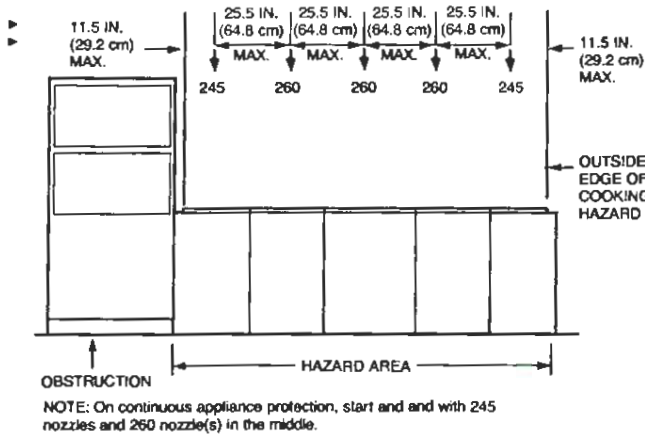

FIGURE 97
001713

- When an appliance requires dedicated protection with a protected area intended for overlapping appliance nozzle protection, the group protection option will be required for appliances on either side of the appliances using dedicated protection. Group protection using overlapping appliance nozzles must begin with the protected appliance(s) adjacent to the dedicated appliance protected. An overlapping appliance nozzle(s) must be positioned within 11.5 in. (29.2 cm) of the edge(s) of the appliance hazard surface area(s) adjacent to the dedicated nozzle protection. See Figure 98.

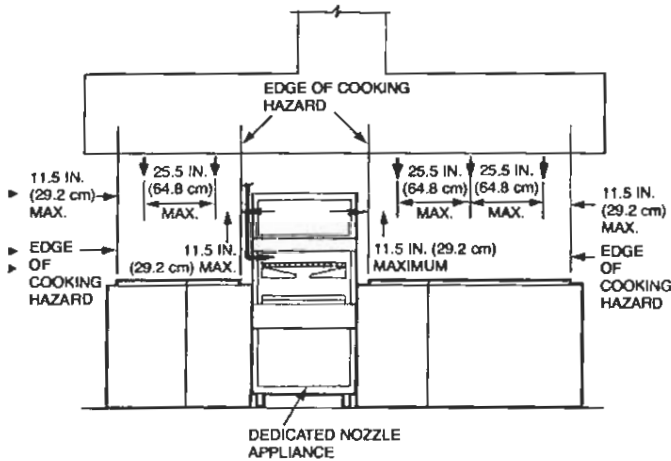

FIGURE 98
001756

- On protected appliances, all hazard surfaces located in a group must be within 40-45 in. (1-1.1 m) from the nozzle(s). Once that dimension is exceeded, a new group must be started. See Figure 99.

Note: The supply pipe feeding nozzle groups is to be at the same elevation. Adjust height for each group only by varying lengths of nozzle drops.

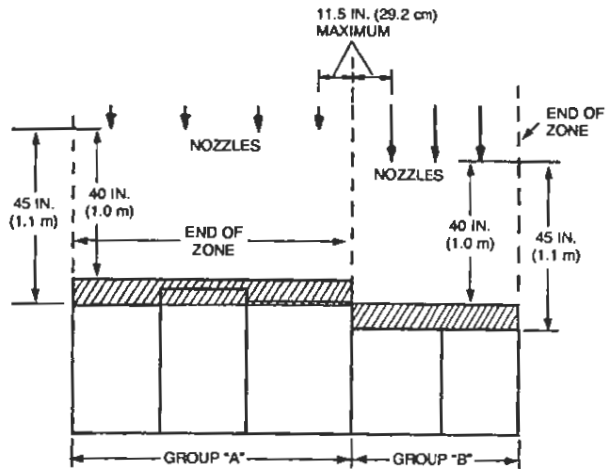

FIGURE 99
007509

Detection Requirements For Overlapping Appliance Protection

When utilizing overlapping appliance protection, fusible link detectors must be installed on a maximum of 2 ft (0.61 m) centers, starting with detectors located in (under) the duct opening(s).

Starting from the detector under the duct opening, add detectors on 2 ft (0.61 m) maximum spacing until the complete length of the plenum area is covered, from one end to the other. The location of the last detector on each end of the plenum must not exceed 2 ft (0.61 m) from end of plenum.

Note: Standard detector placement can also be utilized when using overlapping protection. However, the overlapping detector option cannot be used when utilizing standard R-102 protection. Refer to Pages 4-57 and 4-58 for detector placement.

TANK AND CARTRIDGE REQUIREMENTS

Once the hazard analysis is completed and the total nozzle flow numbers are established, the quantity and size of agent tanks and cartridges needed to supply the nozzles with the proper volumes of agent at the proper flow rates can be determined. For cartridges used in the regulated release mechanism, flow capacities, tank quantities and sizes, and regulated release cartridge options are given in the table below.

Total Flow Numbers*	Quantity and Size of Tank(s)	Regulated Release Cartridge Options	
		Nitrogen	Carbon Dioxide
1 – 5	(1) 1.5 Gallon	LT-20-R	101-10
6 – 11	(1) 3.0 Gallon	LT-30-R	101-20
11 – 16	(1) 1.5 Gallon	Double	101-30
	(1) 3.0 Gallon		
16 – 22	(2) 3.0 Gallon	Double	101-30**
16 – 22	(2) 3.0 Gallon (Manifold)	Double	–
22 – 33	(3) 3.0 Gallon	Double	–

When one or more regulated actuators are used, the following tank and cartridge combinations apply for each regulated actuator:

Regulated Actuator Tank(s)	Regulated Actuator Cartridge
(1) 1.5 Gallon	LT-20-R or 101-10
(1) 3.0 Gallon	LT-30-R or 101-20
(1) 1.5 Gallon and (1) 3.0 Gallon	LT-A-101-30 or 101-30** or double tank
(2) 3.0 Gallon	LT-A-101-30 or 101-30** or double tank
(2) 3.0 Gallon (Manifold)	LT-A-101-30 or Double
(3) 3.0 Gallon	LT-A-101-30 or Double

* For exceptions to maximum flow numbers, see Distribution Piping Requirements for 1.5 gallon and 3.0 gallon systems in this Section.

** The 101-30 cartridge can not be used when (2) two 3.0 gallon tanks are manifolded together.

For higher total flow numbers (23 to 110), multiple cartridges and regulated actuators are required as shown in the System Selection Guide in Section IX – Appendix.

ACTUATION AND EXPELLANT GAS LINE REQUIREMENTS

This section contains the guidelines for installing the actuation and expellant gas lines between the regulated release mechanism regulator, each regulated actuator regulator, and each agent tank. These limitations should be considered when selecting the component mounting locations.

The **actuation gas line** is the length of pipe and/or hose that is run from either the AUTOMAN Regulated Release Assembly or the Remote Release Assembly that directs high pressure from the cartridge in the release to actuate one or more additional Regulated Actuator Assemblies. The actuation gas line can consist of 1/4 in. Schedule 40 black iron, chrome-plated, stainless steel, or galvanized steel pipe and fittings, and/or factory supplied stainless steel braided actuation hose.

The **expellant gas line** is the length of pipe that is run from the regulator in either the AUTOMAN Regulated Release Assembly or a Regulated Actuator Assembly that directs regulated pressure to the agent storage tanks to pressurize the tank and discharge the agent. The expellant gas line shall consist of 1/4 in. Schedule 40 black iron, chrome-plated, stainless steel, or galvanized steel pipe and fittings.

Actuation Gas Line – 6 to 8 Tanks Maximum

* 8 Tank maximum reflects the utilization of 3 tank regulated actuators.

1. Use only 1/4 in. Schedule 40 black iron, hot-dipped galvanized, chrome-plated, or stainless steel pipe and fittings.
2. The actuation gas line piping is installed from the regulated release mechanism to each regulated actuator connected within the system. The total length of the actuation gas line from the regulated release assembly to the regulated actuator assembly(ies) must not exceed 20 ft (6 m) when using an LT-20-R, an LT-30-R nitrogen cartridge, or a 101-10 or a 101-20 carbon dioxide cartridge. See Figure 100.

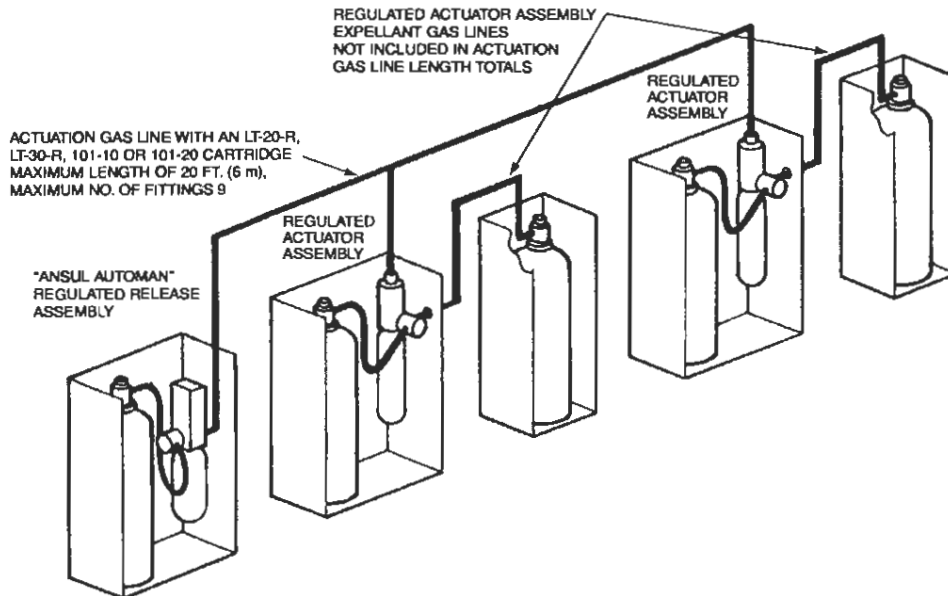

FIGURE 100
000775

SECTION IV – SYSTEM DESIGN

ACTUATION AND EXPELLANT GAS LINE REQUIREMENTS (Continued)

Actuation Gas Line – 6 to 8 Tanks Maximum (Continued)

3. If an expellant gas line is connected to the regulated release assembly along with an actuation gas line, the total combined length of the actuation and expellant gas line **must not exceed 30 ft (9 m)** when using a “double-tank” nitrogen cartridge or a LT-A-101-30 nitrogen cartridge or a 101-30 carbon dioxide cartridge. See Figure 101.
4. A combined total of nine fittings may be used in these lines, eight 90° elbows and one tee. Two 45° elbows equal one 90° elbow.

Actuation Gas Line – 10 to 15 Tanks Maximum

* 15 Tank maximum reflects the utilization of 3 tank regulated actuators.

1. Use only 1/4 in. Schedule 40 black iron, hot-dipped galvanized, chrome-plated, or stainless steel pipe and fittings.
Note: Stainless steel hose and fittings can also be used. See Component Section for detailed information.

ACTUATOR AND EXPELLANT GAS LINES WITH A “DOUBLE TANK” CARTRIDGE OR A 101-30 CARTRIDGE OR A LT-A-101-30 CARTRIDGE
MAXIMUM COMBINED LENGTH – 30 FT (9 m)
MAXIMUM COMBINED FITTINGS – 9

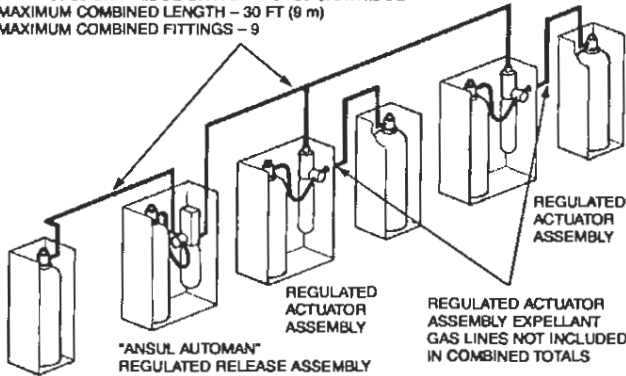

FIGURE 101
000262

2. The actuation gas line piping is installed from the 101 remote mechanical release to each R-102 regulated actuator assembly. The total length of the actuation gas line from the remote mechanical release to the regulated actuator assemblies must not exceed 100 ft (30.5 m).
3. A combined total of 20 elbows and 9 tees may be used in these lines. Two 45° elbows equal one 90° elbow. See Figure 102.
4. Use only a 101-10 carbon dioxide cartridge in the 101 remote mechanical release.
5. A safety vent relief valve (Part No. 15677) is required in the actuation gas line to relieve residual pressure after actuation.

Actuation Gas Line – Using 1/4 in. Stainless Steel Hose

* 15 Tank maximum reflects the utilization of 3 tank regulated actuators.

1. Maximum total length of hose cannot exceed 17.5 ft (5.3 m).
Note: A combination of 1/4 in. stainless steel braided hose and 1/4 in. NPT pipe can be used as long as the total combined actuation gas line length does not exceed 17.5 ft (5.3 m). **Stainless steel braided hose cannot be used for expellant gas lines.** See Figure 102 for additional details.
2. Maximum of 5 regulated actuators allowed
3. Actuated with remote release (Part No. 433485) or Regulated Release Assembly (Part No. 429853)

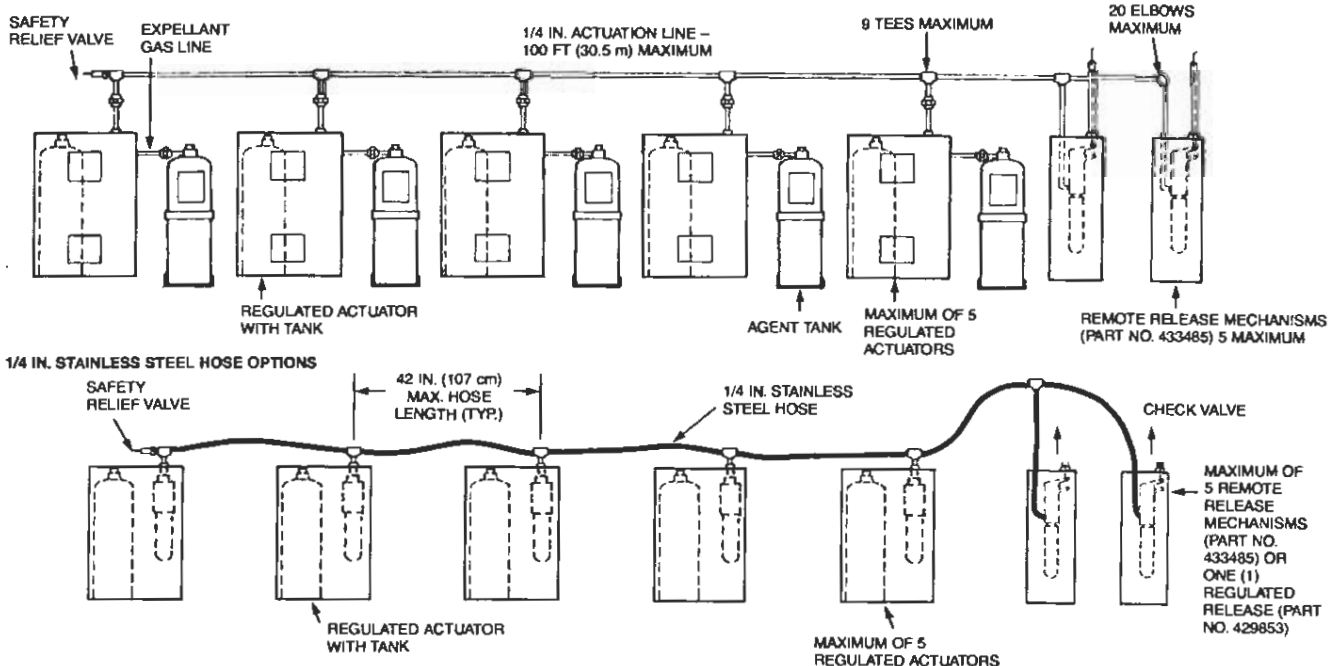

▶ **NOTE:** WHEN MULTIPLE RELEASE ASSEMBLIES ARE UTILIZED, A 1/4 IN. CHECK VALVE, PART NO. 25627, WILL BE REQUIRED AFTER EACH REGULATED RELEASE.

FIGURE 102
000301

**ACTUATION AND EXPELLANT GAS LINE REQUIREMENTS
 (Continued)**

Expellant Gas Line

1. The expellant gas line is installed from the regulated release mechanism in double, three, and multiple-tank systems, and from the regulated actuator assembly in multiple-tank systems. The expellant gas line is the piping and/or hose between the regulator and the tank-enclosure/tank-bracket assembly. The total length of the expellant gas line from the regulated release mechanism or each regulated actuator assembly **must not exceed 30 ft (9 m)** when using a "double-tank" cartridge, an LT-A-101-30 Cartridge, or a 101-30 Cartridge. See Figures 103 and 104.

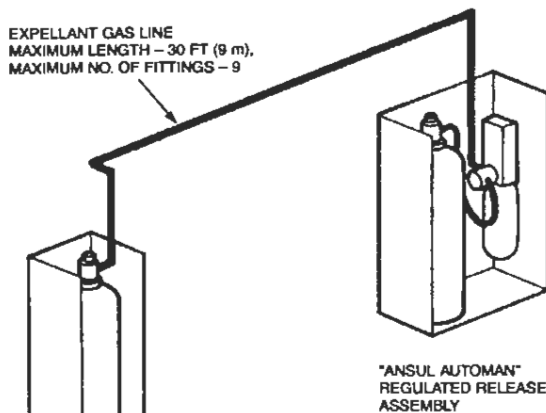

FIGURE 103
 000776

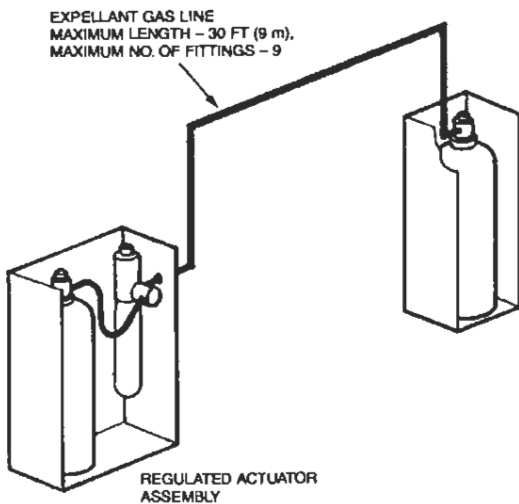

FIGURE 104
 000777

2. A combined total of nine fittings may be used in these lines, eight 90° elbows and one tee. Two 45° elbows equal one 90° elbow.
3. If two tanks are connected to the regulated release assembly in a multiple-tank system arrangement, the total combined length of the actuation and expellant gas lines **must not exceed 30 ft (9 m)** when using a "double-tank" nitrogen cartridge, an LT-A-101-30 nitrogen cartridge, or a 101-30 carbon dioxide cartridge. See Figure 101.

4. If three 3.0 gallon tanks are connected to the regulator in either a regulated release or regulated actuator assembly, only factory supplied expellant gas hose assemblies will be utilized. Refer to Distribution Piping Requirements – 9.0 Gallon System, page 4-55 for additional design requirements.

DISTRIBUTION PIPING REQUIREMENTS

Once the nozzle placement and quantity of tanks has been determined, it is then necessary to determine the piping configurations between the tank adaptor and each discharge nozzle. This section contains the guidelines and limitations for designing the distribution piping so that the liquid agent will discharge from the nozzles at a proper flow rate. These limitations should also be referred to when selecting the mounting location for the regulated release mechanism and agent tank.

General Piping Requirements

1. All R-102 system piping is straight line. Therefore, the need for critical lengths and balancing is minimized.
2. Two 45° elbows count as one 90° elbow.
3. Each branch line includes the tee or elbow leading to it, and all fittings within the branch line itself.
4. The minimum piping length of Schedule 40, 3/8 in. pipe from the tank outlet to any nozzle protecting a range, fryer, or wok must be 6 ft (1.8 m).
5. Pipe lengths are measured from center of fitting to center of fitting. See Figure 105.

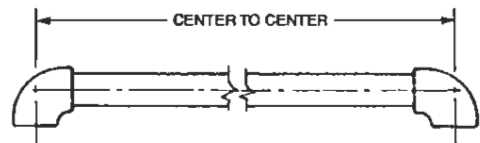

FIGURE 105
 000778

6. All distribution piping must be 3/8 in. Schedule 40 black iron, chrome-plated, or stainless steel. **Do not use hot dipped galvanized pipe on the distribution piping.**
7. All threaded connections located in and above the protected area must be sealed with pipe tape. Tape should be applied to male threads only. Make certain tape does not extend over the end of the thread, as this could cause possible blockage of the agent distribution.
8. Before installing blow-off caps on nozzles, apply a small amount of Dow Corning No. 111 silicone grease across the opening in the nozzle tip and also a small amount coating the exterior of the blow-off cap. This will help keep cooking grease from building up on the cap.
9. Tees used in the distribution piping can be used as thru tees, side outlet tees, or bull tees.

SECTION IV – SYSTEM DESIGN

UL EX3470 ULC EX3470 Page 4-50
 REV. 5 7-1-09

DISTRIBUTION PIPING REQUIREMENTS (Continued)

Supply and Branch Line Identification

The R-102 distribution piping network is broken down into four specific pipe runs: the Supply Line, the Duct Branch Line, the Plenum Branch Line, and the Appliance Branch Line. See ▶ Figure 106.

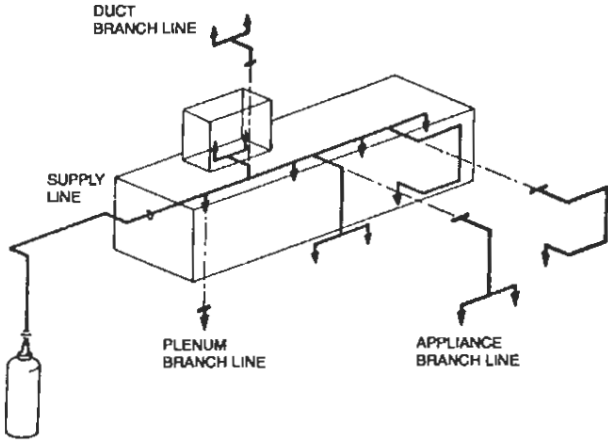

NOTE: THIS IS A CONCEPTUAL DRAWING ONLY.
 THIS IS NOT AN ACTUAL INSTALLATION.

FIGURE 106
 000779

NOTE: THESE ARE EXAMPLES ONLY. OTHER CONFIGURATIONS CAN BE DESIGNED.

SUPPLY LINE

The Supply Line is defined as the length of pipe which runs from the agent tank outlet to the last branch line (whether a duct, appliance, or plenum branch line). This includes all supply line fittings except for the tees or elbows leading to the branch lines. See ▶ Figures 106 and 107.

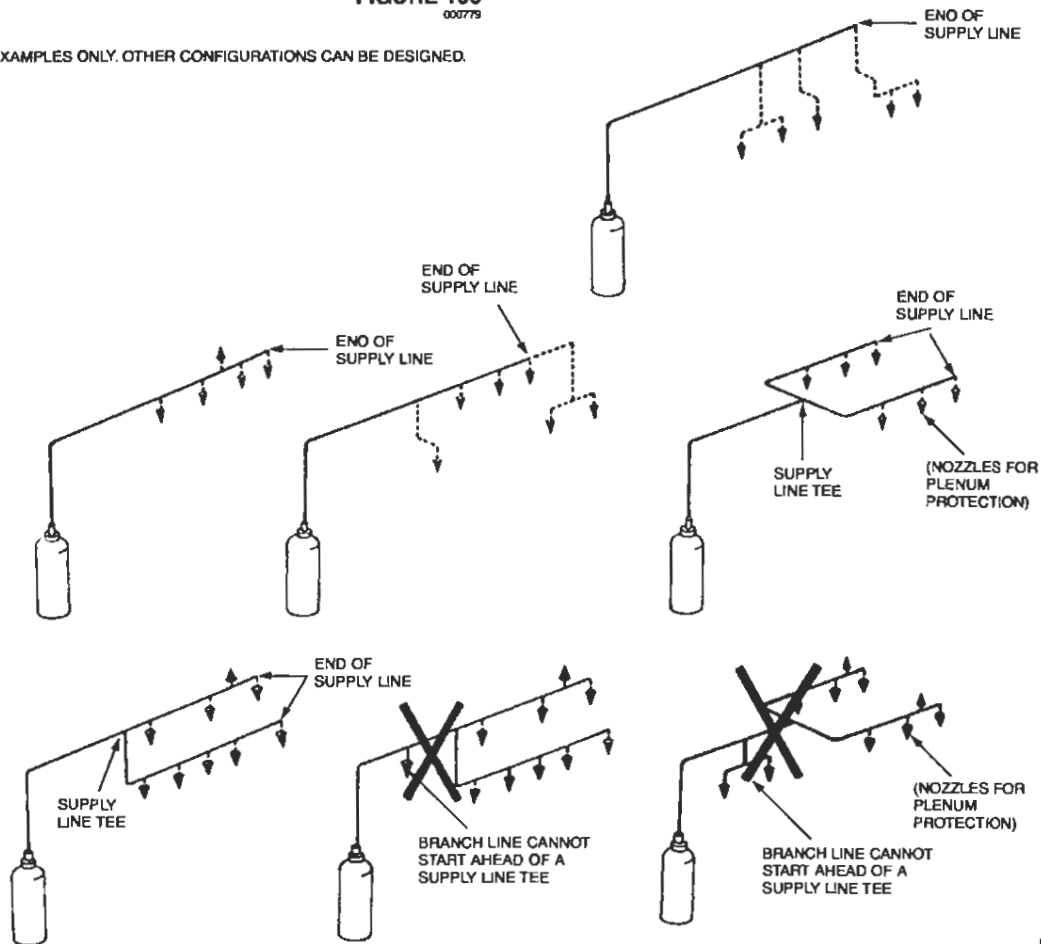

FIGURE 107
 000780

DISTRIBUTION PIPING REQUIREMENTS (Continued)
Supply and Branch Line Identification (Continued)

NOTICE

Branch lines cannot start ahead of a supply line tee.

DUCT BRANCH LINE

The Duct Branch Line is defined as the length of pipe which runs from the supply line to the duct nozzle(s). This includes all branch line fittings as well as the tee or elbow used to start the branch line.

▶ See Figures 107 and 108.

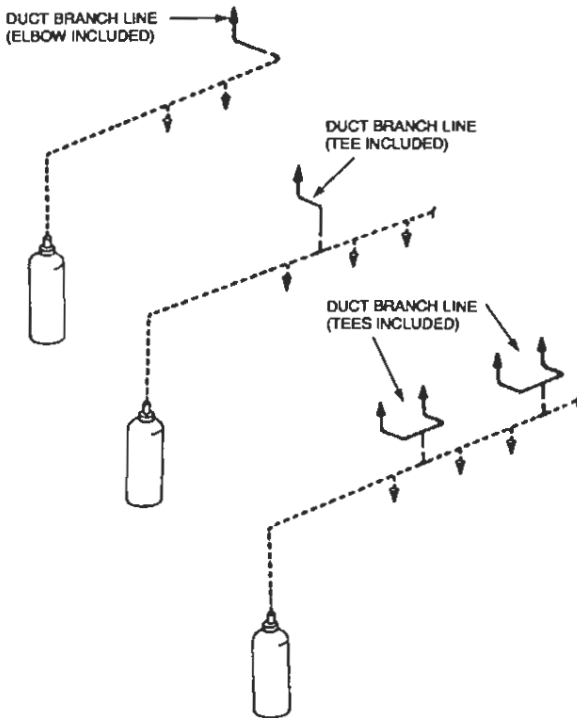

FIGURE 108
000781

PLENUM BRANCH LINE

The Plenum Branch Line is defined as the length of pipe which runs from the supply line to the plenum nozzle(s). This includes all branch line fittings as well as the tee or elbow used to start the branch line. ▶ See Figures 106 and 109.

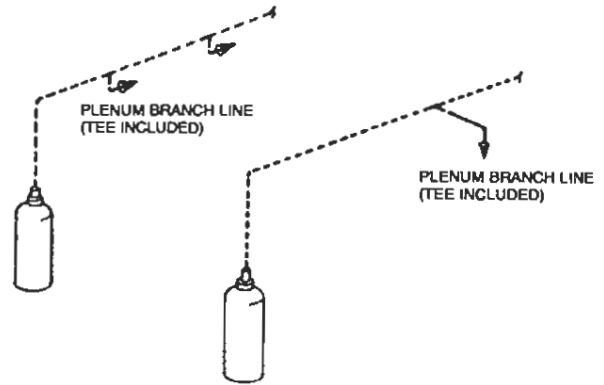

FIGURE 109
000782

APPLIANCE BRANCH LINE

The Appliance Branch Line is defined as the length of pipe which runs from the supply line to the appliance nozzle(s). This includes all branch line fittings as well as the tee or elbow used to start the branch line. ▶ See Figures 107 and 110.

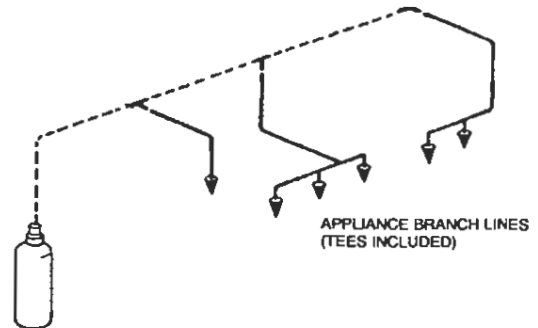

FIGURE 110
000783

SECTION IV – SYSTEM DESIGN

DISTRIBUTION PIPING REQUIREMENTS (Continued)

Distribution Piping Requirements – 1.5 Gallon System

DUCT, PLENUM, AND APPLIANCE PROTECTION

- 1. This option allows for duct protection, plenum protection, appliance protection, or any combination. However, only one (1) duct nozzle may be used, either a 1W or a 2W, nozzle.
- 2. All distribution piping, supply and branch, must be 3/8 in. Schedule 40 black iron, chrome-plated, or stainless steel.
- 3. Each 1.5 gallon tank allows a maximum of five flow numbers.*
- 4. The pipe length between the start of the first branch line and the start of the last branch line must not exceed 8 ft (2.4 m). When the supply line is split, the **combined length** of both legs of the supply line (start of first branch line to start of last branch line) must not exceed 8 ft (2.4 m). See Figure 111.
- 5. The combined length of all branch lines must not exceed 22 ft (6.7 m). See Figure 112.
- 6. The requirements of the following table must not be exceeded:

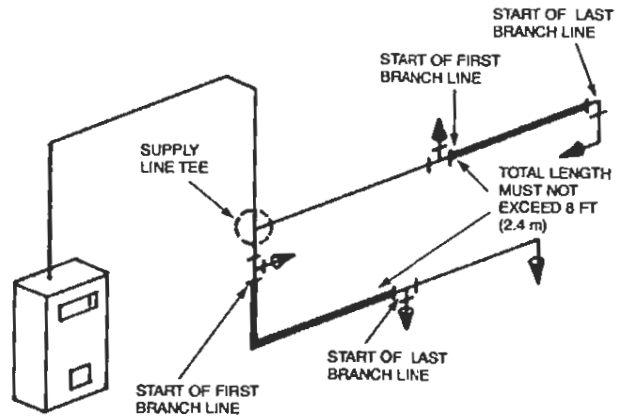

FIGURE 111
000784

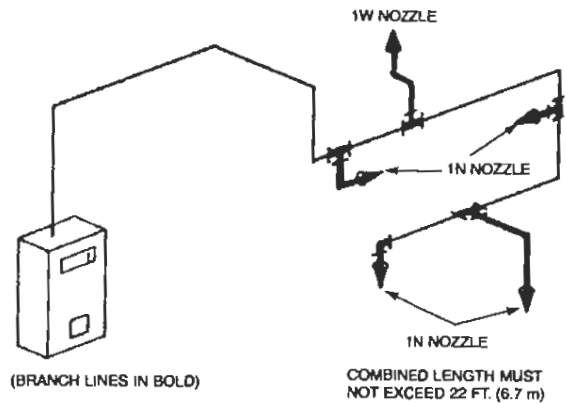

FIGURE 112
000785

Requirements	Supply	Duct Branch Line	Plenum Branch Line	Appliance Branch Line
Pipe Size	3/8 in.	3/8 in.	3/8 in.	3/8 in.
Maximum Length	40 ft (12.2 m)	6 ft (1.8 m)	4 ft (1.2 m)	10 ft (3 m)
Maximum Rise	6 ft (1.8 m)	4 ft (1.2 m)	2 ft (0.6 m)	2 ft (0.6 m)
Maximum 90° Elbow	9	4	4	6
Maximum Tees	1	1	2	3
Maximum Flow Numbers	5*	2	2	3

*** Exceptions:**

- 1. Six (6) flow numbers are allowed when a duct branch line is the last branch line on the piping network and no 1N nozzles are used to protect woks or griddles.
- 2. Six (6) flow numbers are allowed when six (6) 1N nozzles are used and none of the nozzles are used to protect woks, griddles, ranges, and salamanders.
NOTE: Only five (5) flow numbers are allowed if a 1N nozzle is used for wok, griddle, range, or salamander protection.
- 3. Six (6) flow numbers are allowed when only two (2) 3N nozzles are used.

DISTRIBUTION PIPING REQUIREMENTS (Continued)

Distribution Piping Requirements – 3.0 Gallon System

1. The maximum length between the start of the first branch line and the start of the last branch line must not exceed 24 ft (7.3 m). When the supply line is split, the **combined total** of both legs of the supply line (from the start of the first branch line to the start of the last branch line) must not exceed 24 ft (7.3 m). See Figure 113.
2. The total length of all branch lines must not exceed 36 ft (10.9 m). See Figure 113.
3. Use a 3/8 in. union to connect the tank adaptor to the 3/8 in. supply line.
4. A maximum of two nozzles are allowed per duct branch line.
5. The requirements of the following table must not be exceeded:

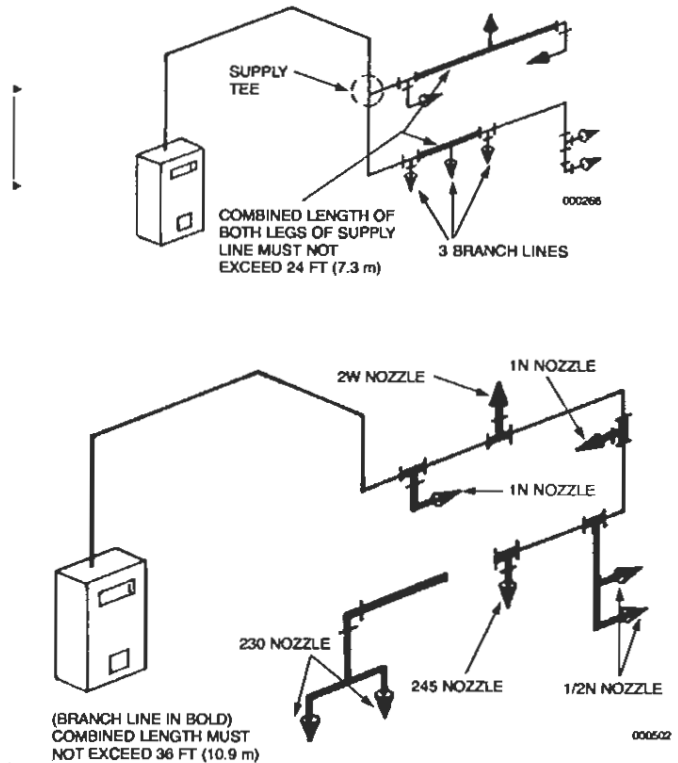

FIGURE 113

Requirements	Supply Line	Duct Branch Line	Plenum Branch Line	Appliance Branch Line
Pipe Size	3/8 in.	3/8 in.	3/8 in.	3/8 in.
Maximum Length	40 ft (12.2 m)	8 ft (2.4 m)	4 ft (1.2 m)	12 ft (3.7 m)
Maximum Rise	6 ft (1.8 m)	4 ft (1.2 m)	2 ft (0.6 m)	2 ft (0.6 m)
Maximum 90° Elbows	9	4	4	6
Maximum Tees	1	2	2	4
Maximum Flow Numbers	11*	4	2	4

***Exceptions:**

1. Twelve (12) flow numbers are allowed in any one tank for duct and plenum protection only.
2. Twelve (12) flow numbers are allowed with any one tank using only two-flow appliance nozzles.
3. Twelve (12) flow numbers are allowed with any one tank using only three-flow appliance nozzles.

Special Instructions:

1. Twelve (12) flow numbers are allowed when four (4) Dean Industries GTI Gas Fryers are protected at low proximity as shown in Figure 66 on Page 4-32. The discharge piping must be as shown in Figure 67 on Page 4-32.
2. For certain McDonald's applications, 11.5 flow numbers are allowed when using a combination of one (1) 2W duct nozzle, one (1) 1/2N electrostatic precipitator nozzle, one (1) 1N plenum nozzle, and four (4) two-flow appliance nozzles. Contact ANSUL Applications Engineering Department for additional information.

SECTION IV – SYSTEM DESIGN

DISTRIBUTION PIPING REQUIREMENTS (Continued)

Distribution Piping Requirements – 6.0 Gallon Manifolder System

As an option to piping two (2) 3.0 gallon tanks separately, two (2) 3.0 gallon tanks can be manifolded together to share a common agent distribution line. Only (2) 3.0 gallon tanks connected to the same regulator can be manifolded. The following requirements must be met when manifolding:

1. All piping must be 3/8 in. Schedule 40.
- ▶ 2. See Figure 115 for tank connections.
3. The length of supply line piping between the start of the first branch line and the start of the last branch line must not exceed 24 ft (7.3 m). See Figure 94. When the supply line is split, the combined total of both legs of the supply line (from the start of the first branch line to the start of the last branch line) must not exceed 24 ft (7.3 m).
- ▶ 4. The combined length of all branch lines must not exceed 36 ft (10.9 m). See Figure 114.
5. A maximum of 22 flow numbers are allowed.
6. The requirements of the following table must not be exceeded.

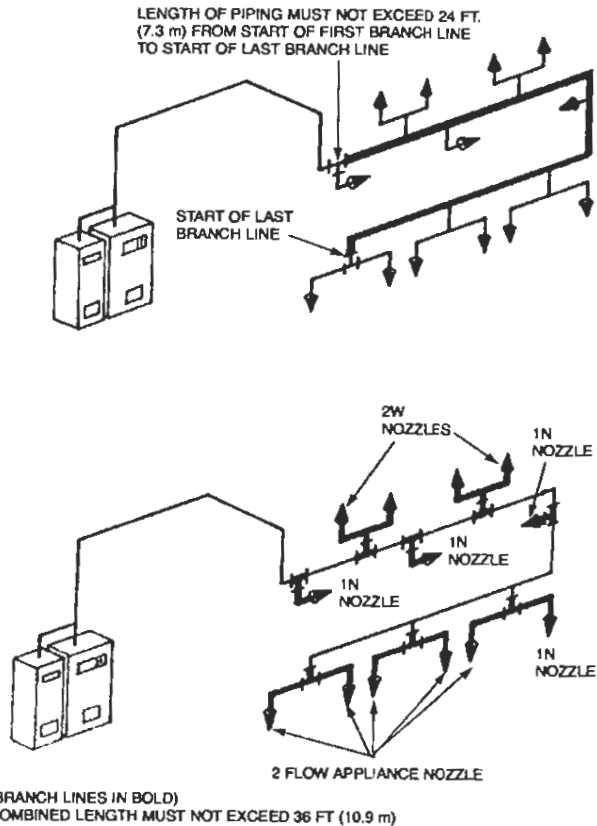

FIGURE 114
000267

Requirements	Supply Line	Duct Branch Line	Plenum Branch Line	Appliance Branch Line
Pipe Size	3/8 in.	3/8 in.	3/8 in.	3/8 in.
Maximum Length	32 ft (9.7 m)	8 ft (2.4 m)	4 ft (1.2 m)	12 ft (3.7 m)
Maximum Rise	6 ft (1.8 m)	4 ft (1.2 m)	2 ft (0.6 m)	2 ft (0.6 m)
Maximum 90° Elbows	8	4	4	6
Maximum Tees	2	2	2	4
Maximum Flow Numbers	22	4	2	4

DISTRIBUTION PIPING REQUIREMENTS (Continued)

Distribution Piping Requirements – 6.0 Gallon Manifolded System (Continued)

This configuration consists of two 3 gallon tanks. Both tanks are connected to a common manifold tee and are pressurized from a single double tank (Part No. 73022) nitrogen cartridge in the regulated release assembly. See Figure 115. **Note:** A tank mounting bracket can be utilized instead of the tank/enclosure assembly. See Figure 117.

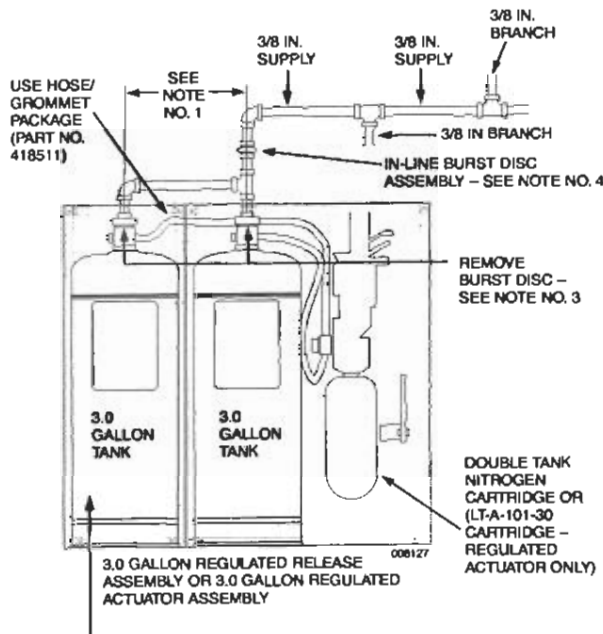

TANK/ENCLOSURE ASSEMBLY

NOTE 1: THE PIPE CONNECTION FROM TANK CENTER TO TANK CENTER CANNOT EXCEED 8-1/2 IN. (21.5 cm). ALSO, OEM RELEASE/BRACKET ASSEMBLY CAN BE UTILIZED WHEN MANIFOLDING 3.0 GALLON TANK.

NOTE 2: ONLY 3 GALLON TANKS CAN BE MANIFOLDED.

NOTE 3: THE BURST DISC THAT IS PART OF THE TANK ADAPTOR/BURST DISC ASSEMBLY MUST BE REMOVED AND MODIFIED. SEPARATE THE ALUMINUM DISC MATERIAL FROM THE PLASTIC GASKET. DISCARD THE ALUMINUM DISC MATERIAL AND REINSTALL THE PLASTIC GASKET BACK INTO THE TANK ADAPTOR/BURST DISC ASSEMBLY.

NOTE 4: THE IN-LINE BURST DISC ASSEMBLY, PART NO. 418790, IS TO BE MOUNTED AS CLOSE TO THE TANK OUTLET AS POSSIBLE. AFTER SYSTEM DISCHARGE, THE ASSEMBLY MUST BE DISASSEMBLED AND A NEW BURST DISC INSTALLED.

FIGURE 115

Distribution Piping Requirements – With Independent Pipe Runs

Independent pipe runs can also be used with the regulated release assembly and the tank/enclosure assembly or tank mounting brackets. See Figure 116. When manifolding is not used, each of the two (2) 3 gallon tanks utilize the piping limitations of a single tank system.

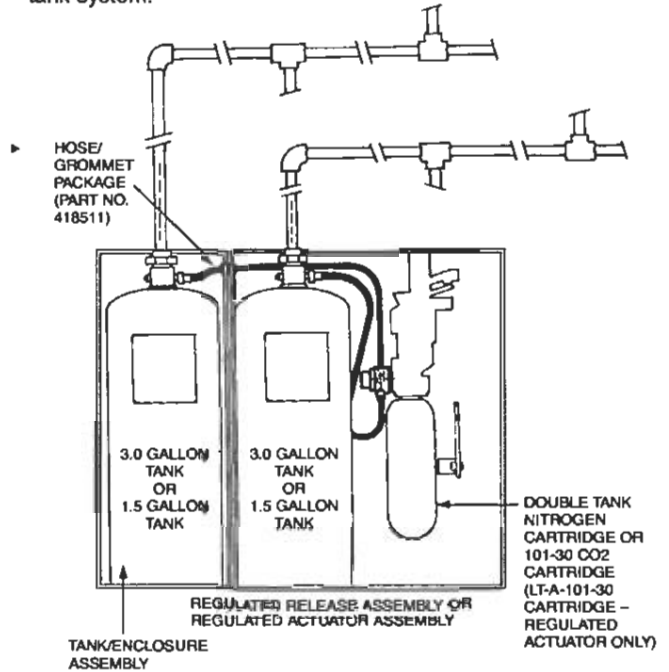

TANK/ENCLOSURE ASSEMBLY

FIGURE 116
000786

Note: If an expellant gas hose is to be used for a second tank in an adjacent tank enclosure or tank bracket assembly, the second tank will need to be installed on the left side of the ANSUL AUTOMAN Regulated Release, with the outlets a maximum of 8 1/2 in. (21.6 cm) from center to center, similar to the manifolded system in Figure 115. Otherwise, the second tank will require 1/4 in. NPT pipe instead of expellant gas hose.

SECTION IV – SYSTEM DESIGN

DISTRIBUTION PIPING REQUIREMENTS (Continued)

Distribution Piping Requirements – 9.0 Gallon System

This optional configuration consists only of three 3-gallon tanks, all pressurized from a single double-tank nitrogen cartridge with expellant gas hoses connected as shown in Figure 117. Tanks No. 1 and No. 2 must be connected directly to the regulator with separate expellant gas hoses and Tank No. 3 must be connected to Tank No. 2 with a third expellant gas hose as shown in Figure 117. Each tank must be connected to an independent distribution piping network as shown in Figure 117. Distribution piping requirements for each network must be as follows:

1. The maximum length between the start of the first branch line and the start of the last branch line must not exceed 24 ft (7.3 m). When the supply line is split, the combined total of both legs of the supply line (from the start of the first branch line to the start of the last branch line) must not exceed 24 ft (7.3 m). See Figure 113.
2. The total length of all branch lines must not exceed 36 ft (10.9 m). See Figure 113.
3. Use a 3/8 in. union to connect the tank adaptor to the 3/8 in. supply line.
4. A maximum of two nozzles are allowed per duct branch line.
5. When using this 9.0 gallon system configuration, no manifolding of distribution piping is allowed.
6. When an ANSUL AUTOMAN Regulated Release is utilized in this configuration, additional regulator actuators cannot be used.
7. Only 3 gallon tanks can be utilized in this configuration.
8. The requirements of the following table must not be exceeded for each 3 gallon tank:

Requirements	Supply Line	Duct Branch Line	Plenum Branch Line	Appliance Branch Line
Pipe Size	3/8 in.	3/8 in.	3/8 in.	3/8 in.
Maximum Length	40 ft (12.2 m)	8 ft (2.4 m)	4 ft (1.2 m)	12 ft (3.7 m)
Maximum Rise	6 ft (1.8 m)	4 ft (1.2 m)	2 ft (0.6 m)	2 ft (0.6 m)
Maximum 90° Elbows	9	4	4	6
Maximum Tees	1	2	2	4
Maximum Flow Numbers	11*	4	2	4

***Exceptions:**

1. Twelve (12) flow numbers are allowed in any one tank for duct and plenum protection ONLY.
2. Twelve (12) flow numbers are allowed with any one tank using only two-flow appliance nozzles.
3. Twelve (12) flow numbers are allowed with any one tank using only three-flow appliance nozzles.

Special Instructions:

1. When four (4) Dean Industries GTI Gas Fryers are protected at low proximity as shown in Figure 66 on Page 4-32, the discharge piping must be as shown in Figure 67 on Page 4-32.
2. For certain McDonald's applications, 11.5 flow numbers are allowed when using a combination of one (1) 2W duct nozzle, one (1) 1/2N electrostatic precipitator nozzle, one (1) 1N plenum nozzle, and four (4) two-flow appliance nozzles. Contact Ansul Applications Engineering Department for additional information.

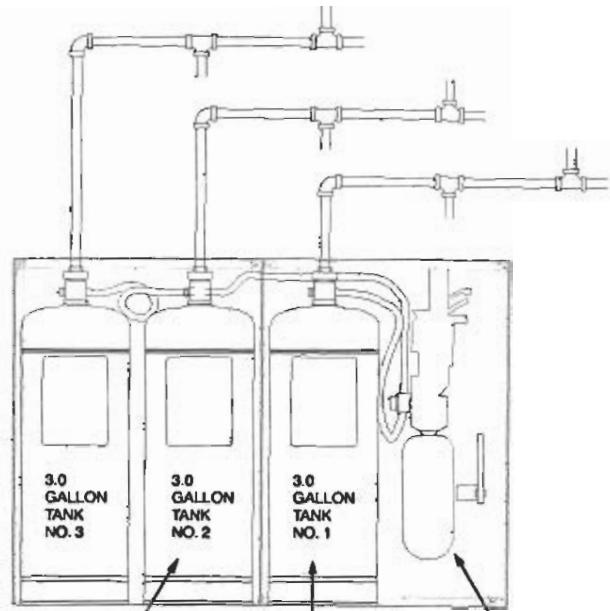

TWO TANK ENCLOSURE ASSEMBLY PART NO. 430324 (INCLUDES (2) HOSES AND (2) GROMMETS) 3 GALLON REGULATED RELEASE ASSEMBLY, OR 3 GALLON REGULATED ACTUATOR ASSEMBLY DOUBLE TANK NITROGEN CARTRIDGE OR LT-A-101-30 CARTRIDGE (REGULATED ACTUATOR ONLY)

NOTE: WHEN THREE (3) 3.0 GALLON TANKS ARE CONNECTED TO ONE (1) AUTOMAN REGULATED RELEASE ASSEMBLY, NO ADDITIONAL REGULATED ACTUATOR(S) ASSEMBLIES CAN BE USED.

FIGURE 117
00126

DETECTION SYSTEM REQUIREMENTS

Once the fire suppression system design has been determined, a detection system design must be completed. This section contains guidelines and limitations for detection system installation.

Detector Identification

The two types of detectors are distinguished from each other by their location in the detection system.

- ▶ 1. The Terminal Detector (Part No. 417368) is the last in a series of detectors, or the only detector used in a single-detector system. This detector is thus named because it is at the point at which the wire rope ends, or "terminates."
- ▶ 2. A Series Detector (Part No. 417369) is any detector located in-line between the regulated release mechanism and the terminal detector.

▶ Detector/Pulley Elbow/Conduit Off-Set Design Limitations

1. Conduit runs, pulley elbows, and number of detectors per system must be within the approved system guidelines. The following requirements must not be exceeded:

	Maximum Number of Detectors per System	Maximum Number of Elbows per System	Maximum Length of 1/2 in. Conduit per System
Scissors Style Detector (Without Off-Set Conduit	15	20	150 ft (45.7 m)
Scissors Style Detector (With Off-Set Conduit	15	16	150 ft (45.7 m)

2. If the hazard requires more than 15 detectors, up to five 101 Remote Releases (Part No. 433485) can be used for system actuation. Each 101 remote release allows the use of a maximum of 15 "scissor" style detectors (14 series and 1 terminal) for a total of 75 detectors if needed.

Detector Placement Requirements

EXHAUST DUCTS

Each exhaust duct must have at least one detector installed in the duct entrance, located in the airstream of the cooking vapors, or at a maximum of 20 ft (6.1 m) into the duct opening. See Figure 118.

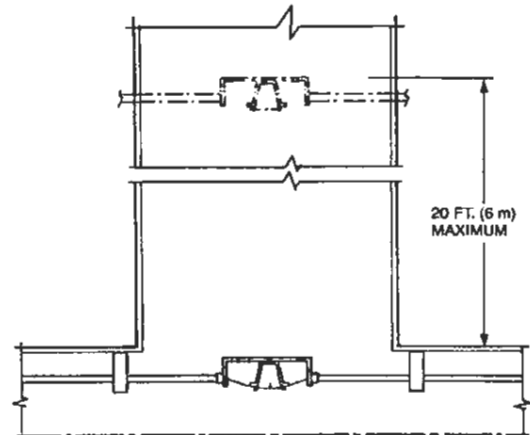

FIGURE 118
000271

NOTICE

When gas appliances are used and the flue gases from the burner are exhausted into the duct, the detector must be kept out of the air stream of these exhaust gases. These gases can be very hot and could actuate the system unnecessarily.

Duct openings that are long and narrow or large enough to require multiple duct nozzles may require additional detectors.

ELECTROSTATIC PRECIPITATOR

If an electrostatic precipitator is located at or near the base of the exhaust duct, it is necessary to locate a detector below the precipitator, at the base of the duct, and also locate one in the duct, just above the precipitator. See Figure 119.

When installing the detector bracket and system conduit, make certain they do not interfere with the operation of the precipitator.

Note: On secondary filtration units utilizing multiple filter stages/media, contact Ansul Technical Services for instructions.

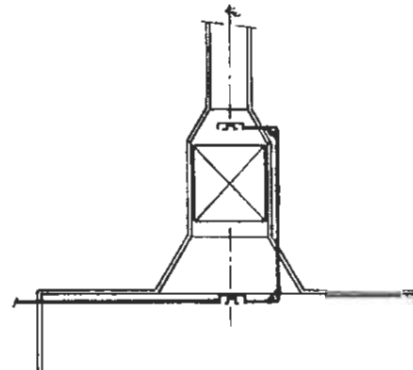

FIGURE 119
000268

SECTION IV – SYSTEM DESIGN

Detector Replacement Requirements (Continued)

COOKING APPLIANCES

If the cooking appliance is located under an exhaust duct where a detector has been mounted, it is normally not necessary to utilize another detector for that cooking appliance, provided the detector is not more than 12 in. (30 cm) into the duct and the appliance has no larger cooking surface than 48 in. x 48 in. (121.9 cm x 129.1 cm). See Figure 120.

Note: If two (2) appliances are located under a duct opening where a detector has been mounted and both appliances together do not exceed a cooking surface of 48 in. x 48 in. (121.9 cm x 121.9 cm) and the detector is located above both the protected appliances, it is not necessary to utilize an additional detector provided the duct detector is not more than 12 in. (30.5 cm) into the duct opening.

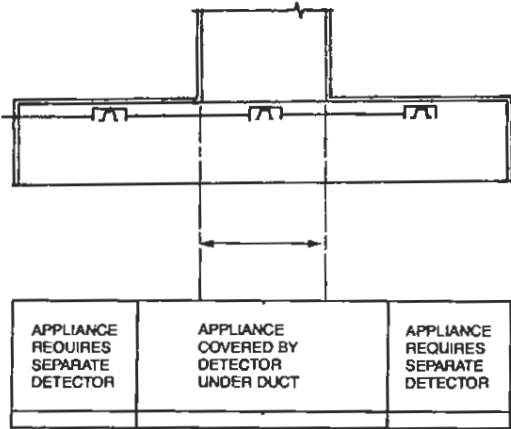

FIGURE 120
000269

Each cooking appliance with a continuous cooking surface not exceeding 48 in. x 48 in. (122 x 122 cm) can be protected by a minimum of one detector. Cooking appliances with a continuous cooking surface exceeding 48 in. x 48 in. must be protected by at least one detector per 48 in. x 48 in. cooking area. Detectors used for cooking appliances must be located above the protected appliance toward the exhaust duct side of the appliance. The detector should be located in the air stream of the appliance to enhance system response time.

Note: For overlapping detector coverage, see Page 4-45 for design requirements.

Detection Line Requirements

CONDUIT

Rigid conduit or 1/2 inch EMT thin-wall conduit may be used. Standard steel conduit fittings (compression type are recommended) must be employed to properly install the detection system. All conduit or pipe must be firmly supported. When using pipe, make certain that all ends are carefully reamed, deburred and blown clear of chips and scale before assembly.

NOTICE

The conduit offset can be used at the top or bottom of the regulated release to change direction of the conduit. The conduit offset cannot be used with pulley tees. All other changes in direction must be made by using ANSUL approved pulley elbows, Part No. 423254 or 415670. See Figure 121.

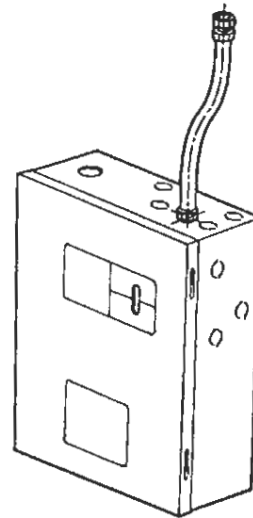

FIGURE 121
000270

Fusible Link Selection

When possible, temperature readings should be taken at each detector location to determine correct fusible link temperature rating. Temperature can be recorded using either a maximum registering thermometer, Part No. 15240, temperature tape or any other accurate thermometer.

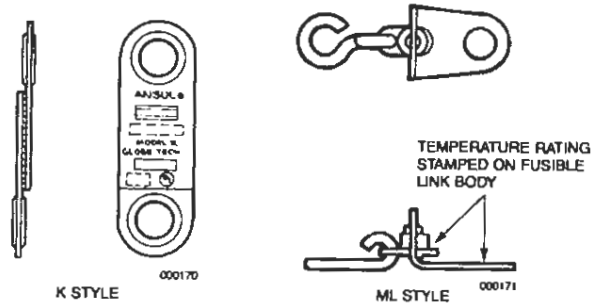

FIGURE 122

Select correct UL Listed fusible link(s) for installation in detector(s) according to the temperature condition. Two styles are available. See Figure 122. See Component Section for detailed temperature ratings.

MANUAL PULL STATION REQUIREMENTS

A remote manual pull station allows the R-102 system to be manually operated at some point distant from the regulated release assembly. The pull station should be installed at a height of 42-48 in. (107-122 cm), in accordance with the requirements of the American Disabilities Act (ADA) and the Authority having Jurisdiction, and located in the path of egress. The pull station is the only source of manual actuation of the regulated release assembly.

The total length of the cable used for each manual pull station within a system must not exceed 150 ft (46 m).

The maximum number of pulley elbows that may be used per pull station is 20.

- ▶ One pulley tee, Part No. 427929, is allowed per cable system.

The maximum length of cable from the AUTOMAN to a pull station is 150 ft (45.7 m) with a maximum of 20 pulley elbows used per side of the tee. As the tee is located farther from the AUTOMAN, the 150 ft (45.7 m) maximum must be observed but as pulley elbows are placed between the AUTOMAN and the tee, they must be deducted from the available pulley elbows (20) allowed on each side.

- Example:** If 10 pulley elbows are placed between the AUTOMAN and the pulley tee, the maximum available pulley elbows left for use on each side of the tee is 10 per side. See Figure 123 for three different examples. (Note: Both must be gas valves or both must be pull stations. Mixing is not allowed.)

TEE CLOSE TO AUTOMAN (EXAMPLE)

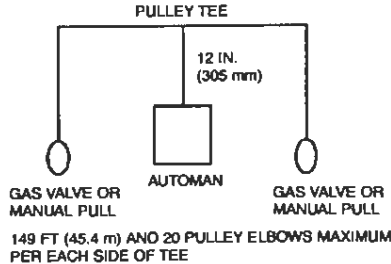

TEE CLOSE TO GAS VALVES OR MANUAL PULL (EXAMPLE)

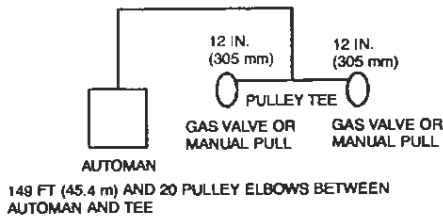

TEE HALFWAY BETWEEN AUTOMAN AND GAS VALVES OR MANUAL PULL (EXAMPLE)
 75 FT (22.9 m) AND 10 PULLEY ELBOWS

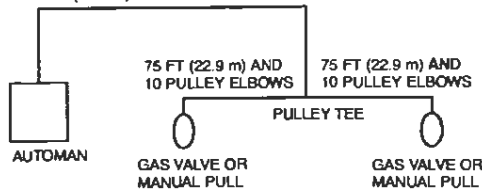

FIGURE 123
004907

Metal Stamped Style – Part No. 4835 or 54011

Parts that may be used for installation of a metal stamped remote manual pull station are:

Description	Part No.
Remote Manual Pull Station Assembly*	54011
Remote Manual Pull Station Assembly	4835
Pulley Elbow	423250
Pulley Elbow	415670
Pulley Tee	427929
*Assembly includes parts listed below:	
1/16 in. Stainless Steel Cable 50 ft. (15 m)	15821
Oval Press-To-Crimp Sleeves	4596
Glass Break Rod (1)	4834

MECHANICAL GAS VALVE REQUIREMENTS

An ANSUL or ANSUL approved mechanical gas shut-off valve system can be attached to the R-102 system. The system works both mechanically and pneumatically by use of an air cylinder located inside the regulated release assembly. Upon actuation of the fire suppression system, a pneumatically-operated air cylinder assembly will mechanically close the gas shut-off valve.

The total length of the cable for each mechanical gas valve must not exceed 150 ft (46 m). The maximum number of pulley elbows that may be used is 20 for each valve.

- ▶ One pulley tee (Part No. 427929) is allowed per cable system.

The maximum length of cable from the AUTOMAN to a gas valve is 150 ft (45.7 m) with a maximum of 20 pulley elbows used per side of the tee. As the tee is located farther from the AUTOMAN, the 150 ft (45.7 m) maximum must be observed but as pulley elbows are placed between the AUTOMAN and the tee, they must be deducted from the available pulley elbows (20) allowed on each side.

- Example:** If 10 pulley elbows are placed between the AUTOMAN and the pulley tee, the maximum available pulley elbows left for use on each side of the tee is 10 per side. See Figure 123 for three different examples.

Parts that may be used for installation of a Mechanical Gas Shut-off Valve are:

Description	Part No.
Gas Valve/Actuator 3/4 in. Assembly (ANSUL)*	55598
Gas Valve/Actuator 1 in. Assembly (ANSUL)*	55601
Gas Valve/Actuator 1 1/4 in. Assembly (ANSUL)*	55604
Gas Valve/Actuator 1 1/2 in. Assembly (ANSUL)*	55607
Gas Valve/Actuator 2 in. Assembly (ANSUL)*	55610
Gas Valve/Actuator 2 1/2 in. Assembly (ASCO)*	25937
Gas Valve/Actuator 3 in. Assembly (ASCO)*	25938
Pulley Elbow	423250
Pulley Elbow	415670
Pulley Tee	427929
1/16 in. Stainless Steel Cable	15821 or
50 ft (15 m) or 500 ft (152 m) roll	79653
Oval Press-To-Crimp Sleeve	4596
Stop Sleeve (2)	26317
*Assembly includes parts listed below:	
Air Cylinder Assembly	15733
Air Cylinder	15521
Tubing Assembly	15529
Copper Tubing, 1/8 in.	15525
Male Elbow	15523
Male Connector	15522
Machine Screw (2)	15421
Hex Nut (2)	15527
Lockwasher (2)	4141
Visual Inspection Seal (2)	197

SECTION IV – SYSTEM DESIGN

■ UL EX3470 ULC EX3470 Page 4-60
REV. 2 7-1-09

MECHANICAL GAS VALVE REQUIREMENTS (Continued)

All valves above are UL listed and approved. They may be mounted in any position. Pipe threads are type NPT. Ambient operating temperature range of all valves is 32 °F to 120 °F (0 °C to 49 °C). The valves are not weatherproof and must be located indoors in areas approved by the "authority having jurisdiction."

ELECTRICAL GAS VALVE REQUIREMENTS

A UL Listed electrically-operated gas shut-off valve can be attached to the R-102 system to provide an electrical means of shutting off the gas line at a predetermined point. If an electric gas shut-off valve is used in the system it must be attached with both an electric (snap-action) switch and a manual reset relay. For more information on the types of electric (snap-action) switches, refer to the Electrical Switch, Field Installation section. The manual reset relay is reviewed in this section.

All electrical connections should be performed by a **QUALIFIED ELECTRICIAN** and in accordance with authority having jurisdiction.

The following is a brief explanation of how the R-102 system operates with an Electric Gas Shut-off Valve attached:

With the regulated release cocked in the ready condition, the normally closed contacts in the snap-action switch allow current to flow to the manual reset relay. With the relay coil energized, normally open contacts in the reset relay close, allowing the solenoid in the gas valve to be energized.

Once the R-102 system is activated, the normally closed contacts in the snap-action switch will open, de-energizing the reset relay. This will, in turn, open the contacts in the relay which will cause the gas valve to become de-energized and close.

The system must be re-armed and the "push to reset" button on the reset relay must be operated to reopen the gas valve.

It is important to note that a power failure or an electrical power interruption will cause the gas valve to close even though the system was not fired.

In either case, whether in a fired condition or when a power failure has occurred, the manual reset relay and electric gas shut-off valve must be reset to resume a normal operating condition. For resetting, refer to the "Recharge and Resetting Procedures" section in this manual.

Approvals

ANSUL gas valves listed in this section are UL listed and approved for 110 VAC. If more information is required, refer to the Gas and Oil Equipment List of Underwriters Laboratories, Inc. under "Electrically Operated Valves Guide No. 440 A5" or consult Ansul Incorporated, Marinette, Wisconsin 54143-2542.

If other gas valves are used, they shall be "UL listed electrically-operated safety valves for natural or LP gas as required, of appropriate pressure and temperature rating, 110 VAC/60 Hz." The information on temperature and type of gas that the valves are suitable for may be found in the Gas and Oil Equipment List of Underwriters Laboratories, Inc. under "Electrically Operated Valves Guide No. 440 A5."

The electrically operated gas valve must be of the type that needs to be energized to remain open.

► **Note:** For electrical wiring diagrams, see Installation Section, Pages 5-19.1 through 5-19.3.

Parts that may be used for installation of a 110 VAC Gas Shut-off Valve are:

Description	Part No.
Electric Solenoid Valve, 3/4 in. NPT*	13707
Electric Solenoid Valve, 1 in. NPT*	13708
Electric Solenoid Valve, 1 1/2 in. NPT*	13709
Electric Solenoid Valve, 2 in. NPT*	13710
Electric Solenoid Valve, 3 in. NPT*	17643
Manual Reset Relay (110 VAC)	14702

*Valves are normally closed when de-energized.

ALARM INITIATING SWITCH REQUIREMENTS

The Alarm Initiating Switch can be field mounted within the ANSUL AUTOMAN release. The switch must be used to close a supervised alarm circuit to the building main fire alarm panel when the ANSUL AUTOMAN release actuates. This action will signal the fire alarm panel that there was a system actuation in the kitchen area. The switch kit contains all necessary mounting components along with a mounting instruction sheet. See Page 5-19 for wiring information.

The switch is rated 50 mA, 28VDC.

Part No.	Description
428311	Alarm Initiating Switch Kit

ELECTRICAL SWITCH REQUIREMENTS

► **Note:** Electrical connections shall not be made in the ANSUL AUTOMAN.

The electric (snap-action) switches for the R-102 system are specially designed to fit the regulated release assembly. The switches are intended for use with electric gas valves, alarms, contactors, lights, contractor supplied electric power shut-off devices, and other electrical devices that are designed to shut off or turn on when the fire suppression system is actuated. (See Figures ► 110 through 112 in Installation Section for reference).

Contractors shall supply "UL listed, enclosed industrial control equipment or magnetic switch having a rating matching that of the cooking appliance, coil 110 VAC/60 Hz or 24 VAC/60 Hz."

All electrical connections should be performed by a **QUALIFIED ELECTRICIAN** and in accordance with authority having jurisdiction.

Electric (Snap-Action) Switches that may be field installed are:

Part No.	Description
423878	One Switch Kit
423879	Two Switch Kit
423880	Three Switch Kit
423881	Four Switch Kit

Each switch has a set of single-pole, double throw contacts rated at 21 amp, 1 HP, 125, 250, 277 VAC or 2 HP, 250, 277 VAC.

Note: A relay must be supplied by others if the equipment load exceeds the rated capacity of the switch.

Electrical wiring and equipment shall be installed in accordance with NFPA 70 (National Electrical Code) or the requirements of the authority having jurisdiction.

■

ELECTRICAL SWITCH REQUIREMENTS (Continued)

If a fire alarm system is provided, the fire extinguishing system shall be connected to the alarm system in accordance with the requirements of NFPA 72, National Fire Alarm Code, so that the actuation of the extinguishing system will sound the fire alarm as well as provide the extinguishing function of the system.

If supervision of the electrical detection, electrical actuation or electrical power supply circuit is provided, it shall give prompt audible or visual indication of trouble and shall be distinctive from alarms or indicators indicating operation or hazardous conditions as specified in NFPA 17A.

▶

NOTES:

INSTALLATION INSTRUCTIONS

The installation information listed in this section deals with the limitations and parameters of this pre-engineered system. Those individuals responsible for the installation of the R-102 system must be trained and hold a current ANSUL certificate in an R-102 training program.

Before attempting any installation, the entire system design must have been determined including: Nozzle Placement, Tank Quantity, Actuation and Expellant Gas Piping, Distribution Piping, and Detection System Requirements and an installation sketch should be completed.

MOUNTING THE COMPONENTS

For successful system performance, the regulated release assembly, regulated actuator assembly(ies), and tank-enclosure(s) or tank-bracket assembly(ies) used must be located in areas where the air temperature will not fall below 32 °F (0 °C) or exceed 130 °F (54 °C). The R-102 system is limited to interior applications only. Also, the components must be arranged to conform to the actuation and expellant gas line, and the distribution piping guidelines noted in "System Design."

1.

CAUTION

Use only an ANSUL AUTOMAN Regulated Release assembly or OEM Release/Bracket Assembly. The regulator in this assembly is specifically designed to allow a regulated flow of expellant gas into the agent tank(s). Absence of this regulator could cause the tank(s) to rupture or create an improper system discharge.

Mount the regulated release assembly, OEM Release Assembly, and each regulated actuator assembly required by completing the following steps: See Figures 1, 2, and 3.

- a. Select a rigid surface for mounting the enclosure. The mounting locations must allow the regulated release assembly and the regulated actuator assembly(ies) to be within the limitation of the actuation and expellant gas line lengths and must be able to support the weight of the assembly(ies). When the OEM Release Assembly is mounted inside a cabinet, clearances shall be provided for unrestricted movement of the release assembly components within the closed cabinet.
- b. Detach cover from the enclosure. Remove agent tank from enclosure and the expellant gas line hose from the tank/adaptor assembly.
- c. Secure enclosure box to selected mounting location using the four mounting holes. Use appropriate type of fasteners depending on the mounting surface.
- d. When mounting a 6-gallon manifolded system (or a 6-gallon individual piped system) it is critical that each mounting box is located as shown in Figure 3. There must be a 5/16 in. space between each box. Less than 5/16 in. will cause interference with the covers, and more than a 5/16 in. will cause a gap between the two hose grommets which will expose the hose to possible tampering or damage.

Remove the 7/8 in. knockout in the left side of the ANSUL AUTOMAN release box and remove the 1 in. knockout in the right side of the tank-enclosure box. Install grommets in each (use ANSUL hose/grommet package, Part No. 418511). Remove 1/4 in. plug from back side of R-102 regular and install fixed end of secondary expellant gas hose (included in hose/grommet package, Part No. 418511) in 1/4 in. regulator outlet and wrench tighten.

If not already done, mount both boxes to a rigid surface using appropriate fasteners.

Fill tanks per instructions listed in Steps 3 and 4 on Page 5-2-1.

Next, route hose through grommets and wrench tighten into 1/4 in. inlet of the adaptor on the tank in the tank/enclosure assembly. Also install hose to tank adaptor in regulated release and wrench tighten. See Figure 116 in "Design Section" for details of hose routing.

- ▶ REGULATED RELEASE ASSEMBLY/REGULATED ACTUATOR
- ▶ ASSEMBLY/DOUBLE TANK ENCLOSURE

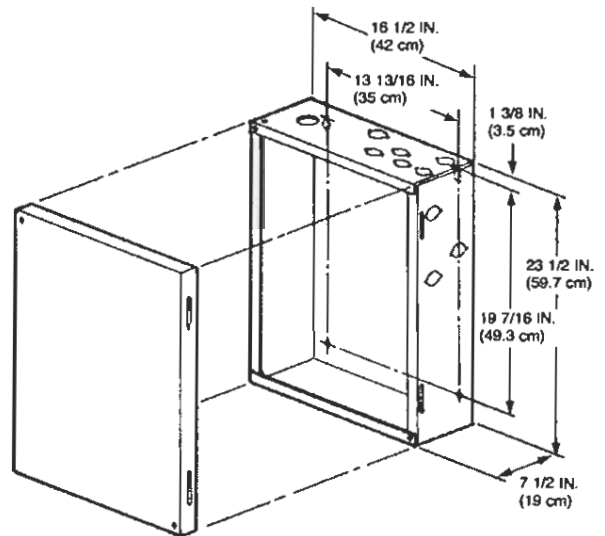

FIGURE 1
000297

MOUNTING THE COMPONENTS (Continued)
OEM RELEASE/BRACKET ASSEMBLY

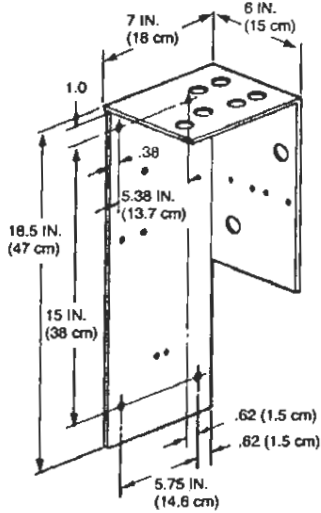
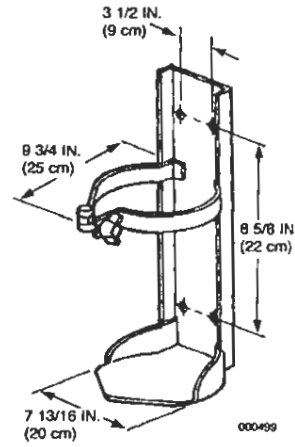

FIGURE 2
000787

3.0 GALLON TANK BRACKET



▶ **SINGLE TANK ENCLOSURE/REMOTE RELEASE**

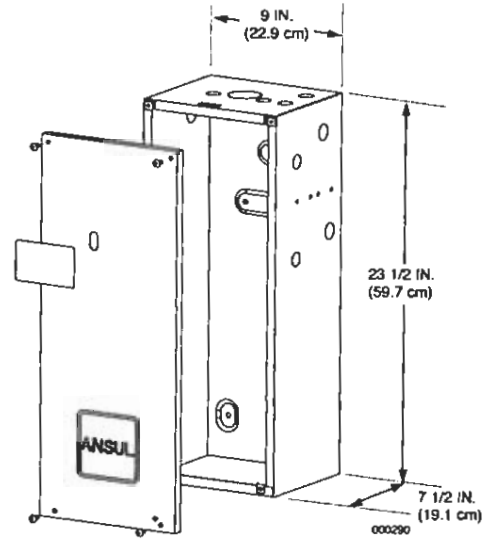

FIGURE 4

▶ **MOUNTING HOLE DIMENSIONS**

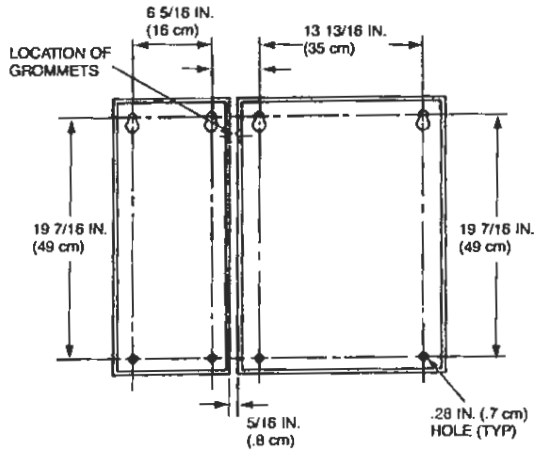

FIGURE 3
000788

CAUTION
 Do not install cartridge at this time or system may be actuated.

2. Mount each tank-enclosure or tank-bracket assembly by completing the following steps:
 - a. Select a rigid, vertical surface for mounting the enclosure or bracket. (Keep in mind that the 3 gallon tank is taller than the bracket. Allow sufficient space for convenient piping and removal).
 - b. Remove tank from enclosure or bracket, and secure enclosure or bracket to the mounting location using the four mounting holes. Use appropriate type of fasteners depending on the mounting surface.

MOUNTING THE COMPONENTS (Continued)

3. Fill each agent tank by completing the following steps:
 - a. Remove tank adaptor/tube assembly from tank fill opening. Visually inspect tank adaptor to determine bursting disc is in place and that silver side is away from tank. See Figure 5.

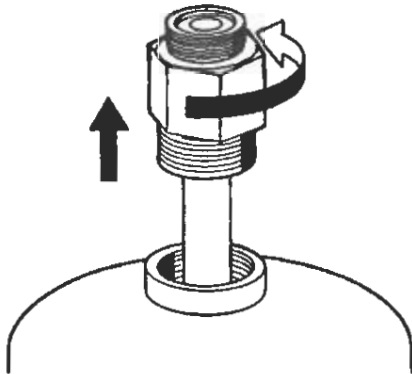



FIGURE 5
000291

b.

 CAUTION
<p>Safety glasses should be worn during transfer operations of ANSULEX Low pH Liquid Fire Suppressant. Avoid contact with skin or eyes. In case of contact, flush immediately with water for 15 minutes. If irritation persists, contact a physician. Do not take internally. If taken internally do not induce vomiting. Dilute with water or milk and contact a physician immediately.</p>

Place plastic funnel in fill opening and fill tank with 1.5 (5.8 L) or 3.0 (11.6 L) gallons of only ANSULEX Low pH Liquid Fire Suppressant. See Figure 6 for detailed filling tolerances. **Note:** Use a funnel with a screen to stop any foreign material from entering the tank. See Figure 6.

 CAUTION
<p>During filling, the agent temperature should be 60 °F to 80 °F (16 °C to 27 °C). DO NOT FILL WITH COLD AGENT. DO NOT OVERFILL. Overfilling may result in agent entering gas hoses and regulator potentially causing system malfunction.</p>

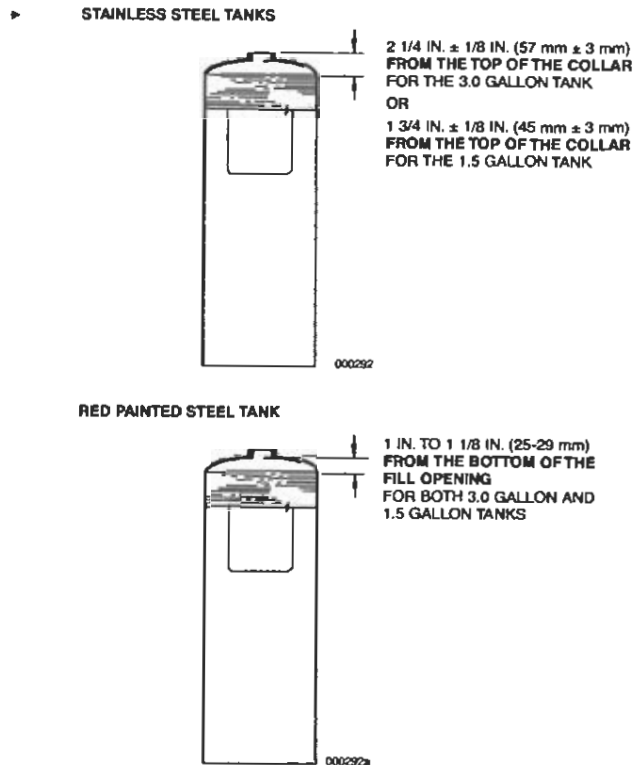

FIGURE 6
000292

- c. Reinstall adaptor/tube assembly to tank by tightening until metal to metal contact is achieved between bottom of adaptor and tank collar.
4. Place each tank into its enclosure or bracket.

SECTION V – INSTALLATION INSTRUCTIONS
UL EX3470 ULC EX3470 Page 5-2.2
REV. 1 7-1-98

NOTES:

INSTALLING THE ACTUATION AND EXPELLANT GAS LINE

► Before installing any actuation or expellant gas line, the design must be determined; and the regulated release assembly, each regulated actuator assembly and each tank-bracket assembly should be securely mounted.

General Piping Requirements

1. Use only 1/4 in. Schedule 40 black iron, hot-dipped galvanized, chrome-plated, or stainless steel pipe and fittings.
2. Before assembling the pipe and fittings, make certain all ends are carefully reamed and blown clear of chips and scale. Inside of pipe and fittings must be free of oil and dirt.
3. The piping and fitting connections must be sealed with pipe tape. When applying pipe tape, start at the second male thread and wrap the tape (two turns maximum) clockwise around the threads, away from the pipe opening.

NOTICE

Do not allow tape to overlap the pipe opening, as this could cause possible blockage of the gas pressure.

Thread sealant or compound must not be used.

4. When connecting actuation or expellant gas line piping, install a 1/4 in. union near the tank inlet for easy disassembly later.

► **Note:** Expellant gas line cannot use stainless steel braided hose.

Actuation Gas Line

► **Note:** See Appendix for complete list and specifications when using rubber hose for actuation gas line.

Install actuation gas line from the regulated release mechanism high pressure side outlet (side opposite regulated outlet) through the appropriate knockout in the enclosure by completing the following steps:

1. Remove the 1/8 in. plug from high pressure side outlet. Install the appropriate fitting for additional equipment attachment as required. A 1/4 x 1/8 in. reducing fitting is required to connect the 1/4 in. actuation line. See Figure 7.

Typical Arrangements For A One Device Connection To Cartridge Receiver

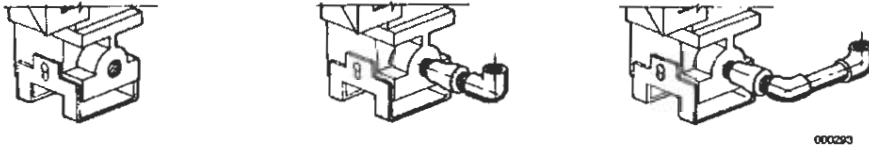

Typical Arrangements For A Two Device Connection To Cartridge Receiver

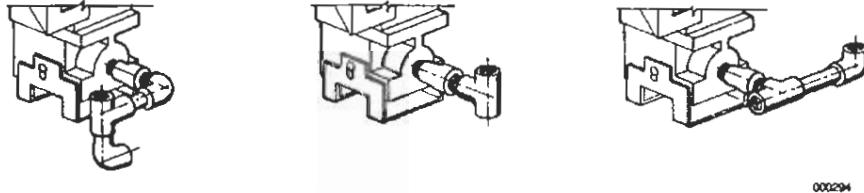

Typical Arrangements For A Three Device Connection To Cartridge Receiver

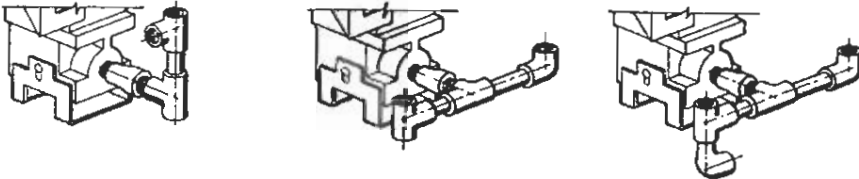

Typical Arrangements for Regulator Connections

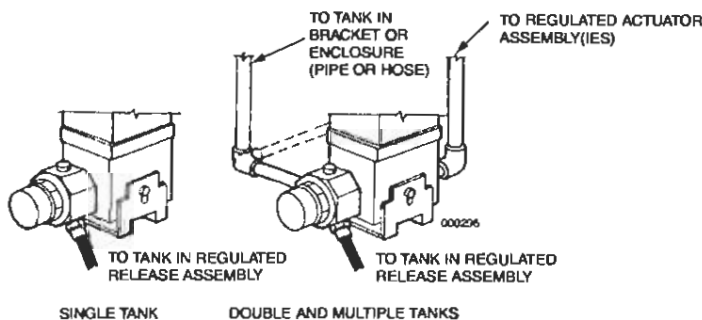

NOTE: WHEN PIPE IS USED, ALL PIPE AND FITTINGS SHALL BE SCHEDULE 40 (STANDARD WEIGHT) BLACK IRON, HOT-TIPPED GALVANIZED, CHROME-PLATED, OR STAINLESS STEEL.

FIGURE 7

**INSTALLING THE ACTUATION AND EXPELLANT GAS LINE
 (Continued)**

Actuation Gas Line (Continued)

- ▶ 2. Run piping or hose up through the regulated release assembly enclosure knockout to the inlet on top of each regulated actuator assembly used within the system.
- 3. The total combined length of the actuation gas line from the regulated release assembly to all regulated actuator assemblies must not exceed 20 ft (6 m) when using an LT-20-R nitrogen cartridge, an LT-30-R nitrogen cartridge, a 101-10 CO₂ cartridge, or a 101-20 CO₂ cartridge. See Figure 8.
- ▶ **Note:** When using stainless steel actuation line, a maximum of 17.5 ft (5.3 m) of hose may be used.
- 4. If an expellant gas line is connected to the regulated release assembly along with an actuation gas line, the total combined length of the actuation and expellant gas line **must not** exceed 30 ft (9.1 m). See Figure 9.
- 5. A combined total of nine fittings may be used in these lines, eight 90° elbows and one tee. Two 45° elbows equal one 90° elbow.

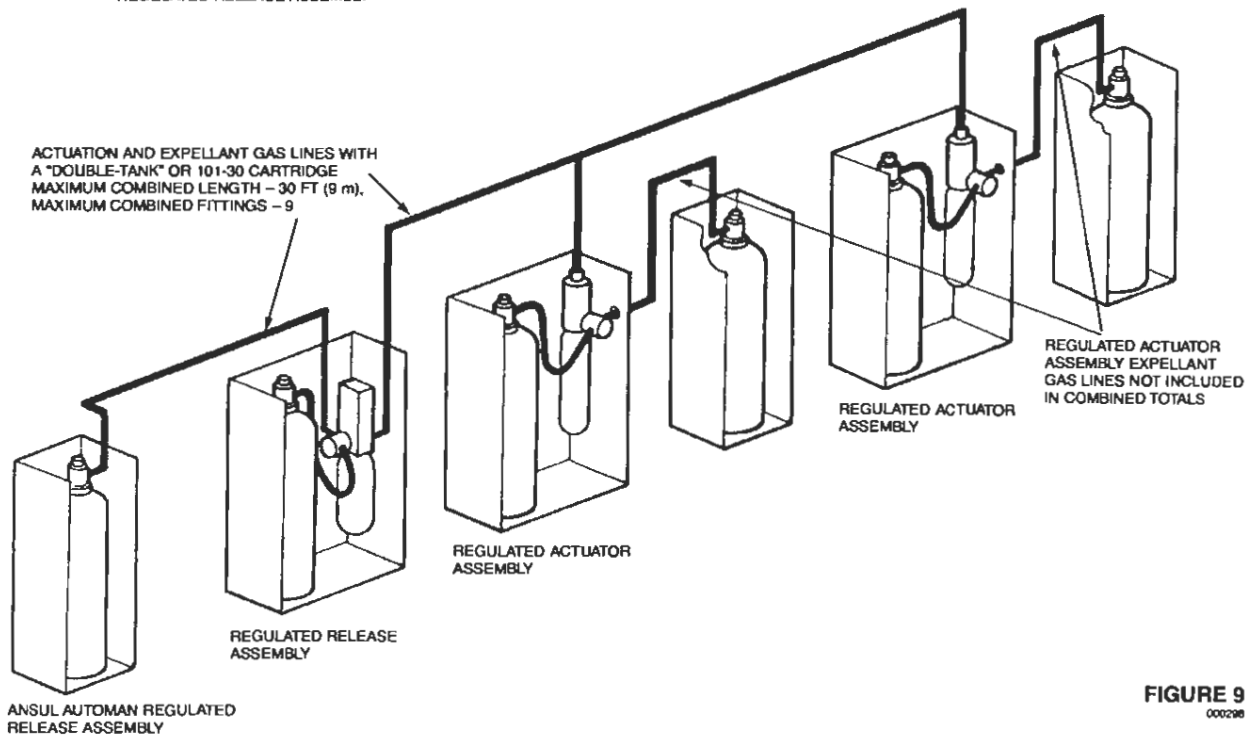
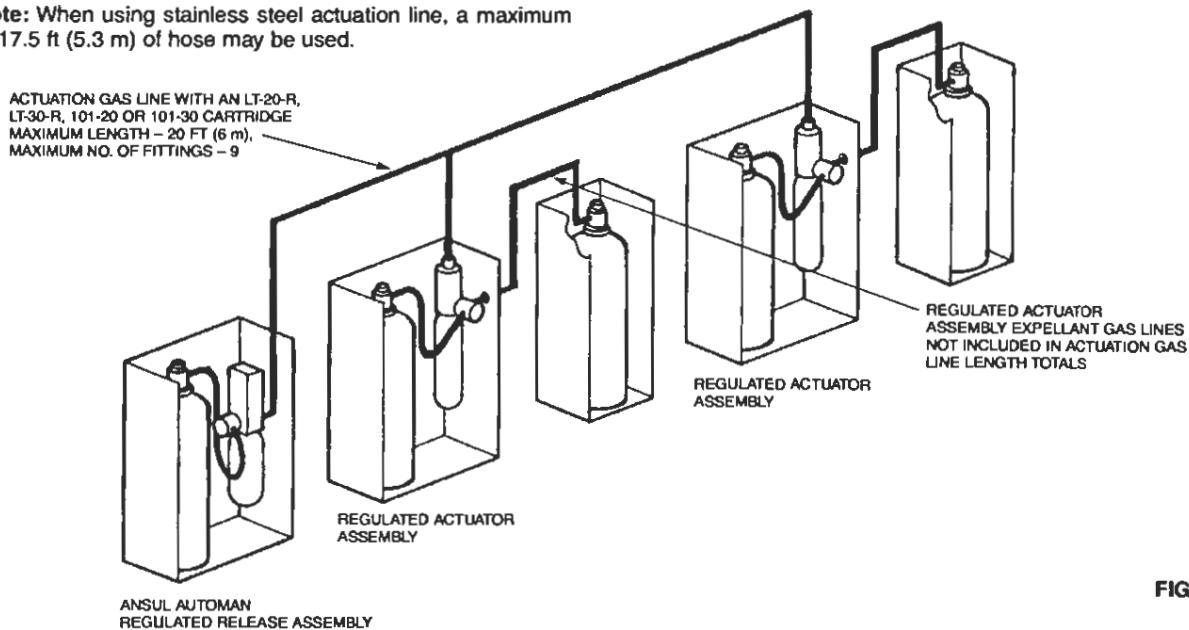

**INSTALLING THE ACTUATION AND EXPELLANT GAS LINE
 (Continued)**

Expellant Gas Line From The Regulated Release Assembly

Install expellant gas line from the regulated release assembly regulator in the enclosure by completing the following steps:

1. The regulated release assembly is shipped with a factory-installed regulator. The regulator has two 1/4 in. outlets, one at the back and one at the bottom. The bottom outlet connects the expellant gas hose to the agent tank which is mounted inside the enclosure. The back outlet is sealed with a 1/4 in. plug.
2. Connect expellant gas hose to the agent tank mounted inside the enclosure.

▶ **TWO TANK, THREE TANK, AND MULTIPLE TANK SYSTEMS:**

If the expellant gas piping is required because an additional tank-enclosure or tank-bracket assembly is being installed, the plug installed in the back outlet must be removed. (See Figure 6 for proper connections to the regulator.)

3. Pipe the 1/4 in. expellant gas line from the regulator back outlet through one of the knockouts provided in the enclosure.

The total length of the expellant gas line from the regulated release assembly **must not exceed 30 ft (9 m)** when using a "double-tank" nitrogen cartridge or a 101-30 CO₂ cartridge. See Figure 10.

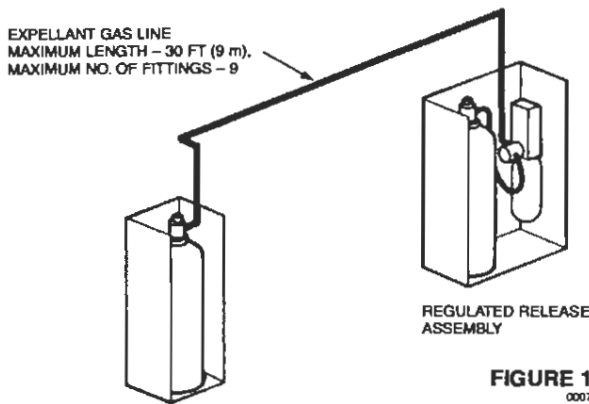

4. If an actuation gas line is connected to the regulated release assembly along with an expellant gas line, the total combined length of the gas lines **must not exceed 30 ft (9 m)** when using a "double-tank" nitrogen cartridge or a 101-30 CO₂ cartridge. See Figure 9.
5. A combined total of nine fittings may be used in these lines, eight 90° elbows and one tee. Two 45° elbows equal one 90° elbow.

Expellant Gas Line From The Regulated Actuator Assembly

Install expellant gas piping from the regulated actuator assembly regulator through the appropriate knockout in the enclosure by completing the following steps:

1. The regulated actuator is shipped with a factory-installed regulator. The regulator has two 1/4 in. outlets 135° from each other. One outlet is sealed by a 1/4 in. plug and the other contains the expellant gas hose for the agent tank which will be mounted within the enclosure. Connect expellant gas hose to the agent tank that is mounted inside the enclosure.
2. Remove the 1/4 in. pipe plug from the regulator side outlet and pipe the 1/4 in. expellant gas line from the regulator through the knockout provided in the enclosure to a tank-enclosure or tank-bracket assembly. A maximum of one tank-enclosure or tank-bracket assembly is allowed per regulated actuator assembly.

The maximum length of the expellant gas line from the regulated actuator to the tank-bracket assembly **must not exceed 30 ft (9 m)**. See Figure 11.

3. A total of nine fittings may be used in these lines, eight 90° elbows and one tee. Two 45° elbows equal one 90° elbow.

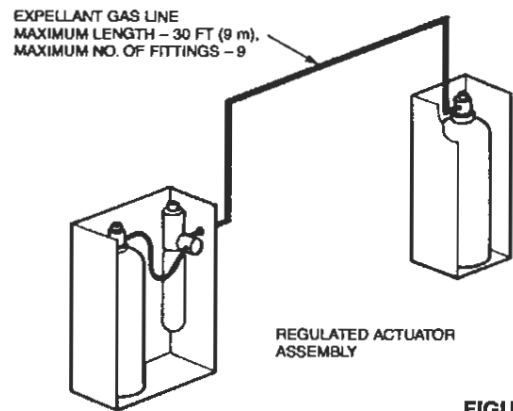

**INSTALLING THE ACTUATION AND EXPELLANT GAS LINE
 (Continued)**

Actuation Gas Line From Remote Release(s) to Regulated Actuators

Install actuation gas piping from the remote release(s) to the regulated actuators by completing the following:

1. Pipe the 1/4 in. actuation gas line from the 1/4 in. outlet in the remote release receiver, through the knockout provided in the top of the release enclosure, to each regulated actuator assembly.

The maximum length of the actuation gas line from the remote release to all regulated actuators **must not** exceed 100 ft. (30.5). See Figure 12. **Note:** Stainless steel hose and fittings can be used. See Component Section for detailed information.

2. A maximum of nine tees and twenty elbows are allowed in the actuation piping. Two 45° elbows equal one 90° elbow. See Figure 12.
3. A safety relief valve (Part No. 15677) must be installed in the actuation piping. See Figure 12.

Actuation Gas Line – 15" Tanks Maximum – Using 1/4 in. Stainless Steel Hose

Note: Not for use with expellant gas line.

1. Maximum hose length cannot exceed 17.5 ft (5.3 m). See Figure 13.
2. Maximum of 5 regulated actuators allowed.
3. Actuated with Remote Release (Part No. 433485) or Regulated Release Assembly (Part No. 429853).

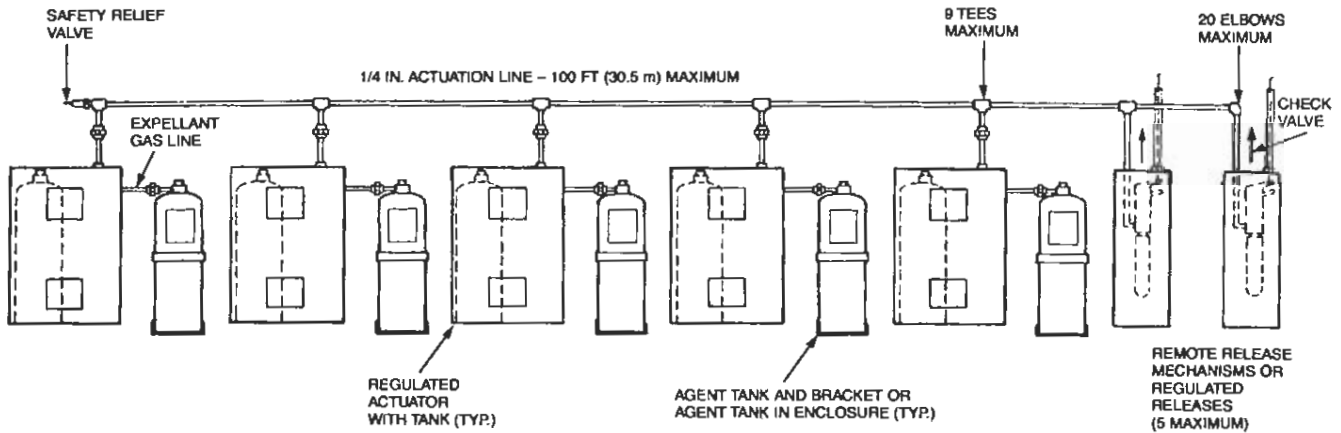
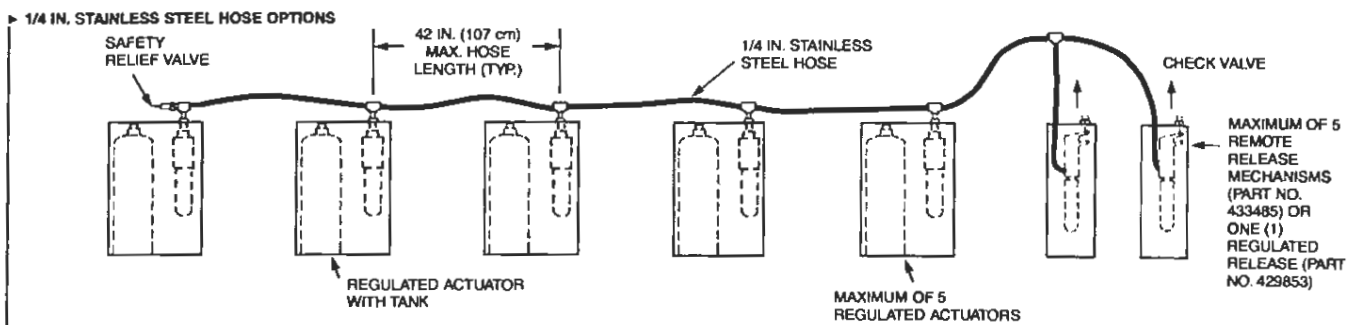

FIGURE 12
000301



NOTE: WHEN MULTIPLE RELEASE ASSEMBLIES ARE UTILIZED, A 1/4 IN. CHECK VALVE, PART NO. 25627, WILL BE REQUIRED AFTER EACH REGULATED RELEASE.

NOTE: * 15 TANKS MAXIMUM REFLECTS THE UTILIZATION OF THREE (3) TANK REGULATED ACTUATORS.

FIGURE 13
000301

INSTALLING THE DISTRIBUTION PIPING

Before the following procedures can be completed, the piping design must already be determined; and the actuation and expellant gas lines from the regulated release, each regulated actuator, and each tank-enclosure or tank-bracket assembly should already be installed.

These installation instructions are identical for single, double, and multiple-tank systems except for the quantity of tanks and hazard areas to be covered.

General Piping Requirements

1. Use Schedule 40 black iron, chrome-plated, or stainless steel pipe and fittings.

NOTICE

Do not use hot-dipped galvanized iron pipe or fittings in the agent distribution piping.

2. Before assembling the pipe and fittings, make certain all ends are carefully reamed and blown clear of chips and scale. Inside of pipe and fittings must be free of oil and dirt.
3. The distribution piping and fitting connections, located in or above the hood or the protected area, must be sealed with pipe tape. When applying pipe tape, start at the second male thread and wrap the tape (two turns maximum) clockwise around the threads, away from the pipe opening.

NOTICE

Do not allow tape to overlap the pipe opening as the pipe and nozzles could become plugged. Thread sealant or compound must not be used as it could plug the nozzles.

4. Distribution piping may be run independently or two agent tanks may be manifolded together and run to the predetermined hazard area. Only agent tanks expelled from the same cartridge may be manifolded.

NOTICE

Closely follow the piping requirements for each size system, as detailed in the "System Design" section, when installing distribution piping.

5. Branchline tees can be used to create more than one branch and can be installed as a thru tee, side outlet tee or bull tee.

Pipe Hanger Recommended Guidelines

1. Space hangers as follows:

Pipe Size	Maximum Recommended Distance Between Hangers
3/8 in.	5 ft (1.5 m)

2. Hangers should be placed between elbows when the distance is greater than 2 ft (0.6 m).

Piping Installation

1. Starting at the tank, pipe directly from the union located on the tank adaptor. A reducing fitting may be necessary to conform to the distribution piping.
2. Based on the piping sketch developed in the "System Design" section of this manual, install the supply line and position the tees at points where branch lines must be installed. See Figure 14.
3. Run all branch lines to the hazard area and connect each nozzle. (Make certain all piping is securely bracketed.)

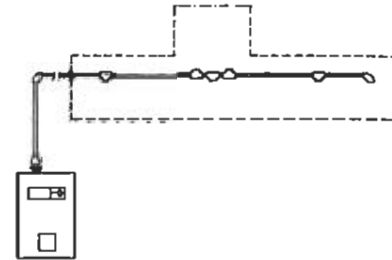

FIGURE 14
000302

4. Make certain all threaded connections are properly tightened. Threaded connections located in the protected area(s) and above the hood must be sealed with Teflon pipe tape, as a minimum. Apply pipe tape to male threads only. Make certain tape does not extend over the end of the thread, as this could cause possible blockage of the agent distribution.

Pipe tape minimizes friction between bearing surfaces of the threads when threading pipe to fittings. The resulting heat may expand the pipe threads before the joint is properly made. When the pipe threads cool and contract in the fitting, the joint may become loosened causing cooking grease to migrate into the distribution piping, and/or leakage at the fitting during a pressure test or agent discharge.

Note: When required to provide pressure testing of pipe or a system discharge test, it is recommended that all pipe connections utilize Teflon pipe tape.

5. Install the correct nozzle(s) for each hazard area as previously designed. Some nozzles are required to be properly oriented before they are positioned for aiming.
6. Aim the nozzles to a pre-determined aim point in accordance with the instructions in the "System Design" section. Using the Nozzle Aiming Device (Part No. 431992) will aid in the aiming process. The device clamps to the nozzle and emits a small laser light that reflects on the surface where it is aiming. If the nozzle is used with Swivel Adapter (Part No. 418569), the nozzle with Aiming Device can be rotated to the exact aiming point and then tightened to hold that angle.
7. Before installing blow-off caps on nozzles, apply a small amount of Dow Corning No. 111 silicone grease across the opening in the nozzle tip and also a small amount coating the exterior of the blow-off cap. **DO NOT FORCE SILICONE GREASE INTO NOZZLE TIP OPENING OR FILL CAP WITH GREASE.**

NOTICE

When using old style metal blow-off cap, make certain the spring clip rotates freely on the metal cap and coat the outside of the cap, including the clip, with Dow Corning No. 111 silicone grease.

8. Make certain a blow-off cap is in place over each nozzle tip. These blow-off caps are designed to keep grease from building-up on the nozzle orifice and inhibiting the agent flow. See Figure 15.



FIGURE 15

SECTION V – INSTALLATION INSTRUCTIONS

UL EX3470 ULC EX3470 Page 5-7.1

REV. 0 7-1-09

INSTALLING THE AGENT DISTRIBUTION HOSE (FOR CASTERED/MOVEABLE EQUIPMENT)

Agent Distribution Hose can be used in the supply line or appliance branch line to allow a castered cooking appliance with castered supports with nozzles attached directly to the appliance, to be moved out of its normal operating position for service or cleaning.



WARNING

The following instructions must be followed in their entirety. Failure to do so may result in the R-102 Fire Suppression System not functioning properly due to incorrect installation.

CRITICAL INSTALLATION REQUIREMENTS

1. Design and installation must be performed by qualified personnel.
2. The Agent Distribution Hose shall not be concealed within or run through any wall, floor, or partition, and shall not have any direct exposure to excessive heat or radiant flame from the cooking appliances.
3. Strong cleaning solutions or chemical substances must not come in contact with the Agent Distribution Hose. These may include acids, solvents, fluxes with zinc chloride, or other chlorinated chemicals. In case of contact, rinse down the Agent Distribution Hose with water and dry thoroughly.
4. Contact with foreign objects, sharp edges, wiring, or substances must be avoided.
5. Bending and flexing of Agent Distribution Hose on moveable appliances (i.e. those factory equipped with casters) should be limited to pulling and pushing the appliances in or out for cleaning or maintenance. The hose shall never be installed or bent tighter than a 3 in. (7.6 cm) radius (6 in. (15.2 cm) diameter) loop.
6. The Agent Distribution Hose must not be kinked, twisted, or have sharp bends when installed or when equipment is pulled away from the wall.
7. Make sure that all fittings are tightened properly.
8. Adequate means must be provided to limit the movement of castered appliances. A 36 in. (91.4 cm) long Restraining Cable supplied with the agent distribution hose is required to be used for all castered appliances using the Agent Distribution Hose. (Refer to Restraining Cable Installation Instructions.)
9. The Restraining Cable requires periodic maintenance to ensure proper operation.
10. The Restraining Cable must be attached to the wall and appliance anytime the distribution hose is connected to the appliance.
11. Do not over-extend the Agent Distribution Hose when moving equipment (for cleaning, maintenance, etc.).

AGENT DISTRIBUTION HOSE INSTALLATION INSTRUCTIONS

Before proceeding, **CAREFULLY** read all instructions, including all **CRITICAL INSTALLATION REQUIREMENTS**.

General Requirements

1. The Agent Distribution Hose, Part No. 434462 (which is part of Discharge Hose and Restraining Cable Kit, Part No. 435982), is 1/2 in. (12.7 mm) diameter x 60 in. (152.4 cm) long and is provided with two (2) male NPT swivels for ease of installation.

2. Maximum of six (6) Agent Distribution Hoses can be used in each agent distribution piping network.
3. Agent Distribution Hose can only be used for castered appliances or appliances setting on castered supports.
4. Maximum of two (2) Agent Distribution Hoses are allowed in the supply line. However, the Agent Distribution Hose can only be used at the castered appliance.
5. Maximum of two (2) Agent Distribution Hoses are allowed in the branch line. An acceptable installation scenario would be providing separate protection of two (2) (side-by-side) appliances, each with its own Agent Distribution Hose and tether, supplied from the same appliance branch.
6. The Agent Distribution Hose is to only be used in the distribution piping of a single 1 1/2 or 3 gal (5.7 or 11.4 L) tank or two (2) manifolded 3 gal (11.4 L) R-102 extinguishing systems or larger systems using combinations thereof. However, the Agent Distribution Hose is never to be used to manifold two (2) 3 gal (11.4 L) tanks.

Installation Requirements

1. Agent Distribution Hose must be connected to 3/8 in. NPT black iron, chrome-plated, or stainless steel fittings. The connection from hose to fitting requires a 1/2 in. x 3/8 in. reducing coupling, Ansul Part No. 436228. All Agent Distribution Hose connections must be sealed with pipe tape. When applying pipe tape, start at the second male thread on the swivel ends of the hose. Wrap the tape (two turns maximum) clockwise around the threads, away from the hose end fitting opening.
2. All connections of distribution piping to Agent Distribution Hose for castered appliances, with distribution nozzles installed/affixed to the appliance, must be located behind the cooking equipment in an area protected from obstructions and possible wear or damage.
3. 3/8 in. schedule 40 pipe will need to be run from the hose connection to the distribution nozzle(s) installed/affixed to the appliance. Pipe must be installed and adequately secured at a height at or below the cooking surface of the appliance. (See Figure 21.)
4. All existing distribution pipe and fitting limitations must be observed and followed. Each flex distribution hose used is to be considered as an equivalent length of 3/8 in. pipe when calculating the acceptable length (ft (m)) of allowable distribution pipe.
5. All hose-to-pipe connection fittings are to be oriented in a vertical down position.
6. The hose connections must be positioned below an elevation where the hose could be exposed to the radiant or convected heat generated by normal cooking operations (such as the horizontal plane of appliance's cooking surface), or to heat from appliance exhaust. As a minimum height, the hose connection shall be no lower than 30 in. (76.2 cm) from the floor. The distribution piping shall be supported and secured per local plumbing practices.
7. Hose ends are to be offset 6 to 8 in. (15.2 to 20.3 cm) center to center of fittings (See Figure 16) to maximize hose life expectancy and facilitate appliance movement. With the appliance in its normal operating position, check the hose bend to make certain the bend is not less than a 3 in. (7.6 cm) bend radius (6 in. (15.2 cm) diameter).

**AGENT DISTRIBUTION HOSE INSTALLATION INSTRUCTIONS
 (Continued)**

Installation Requirements (Continued)

OVERHEAD VIEW

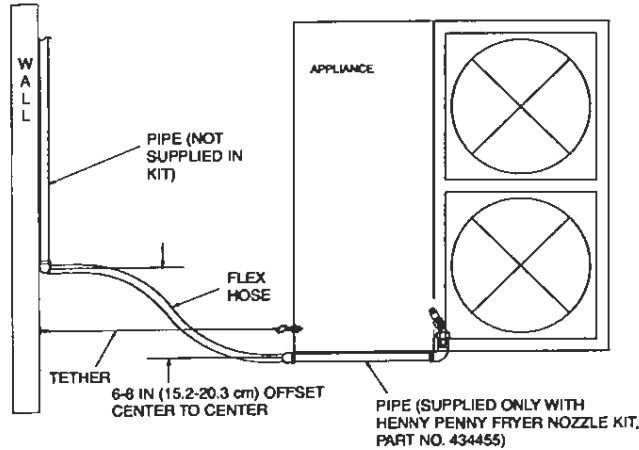

FIGURE 16
007928

Restraining Cable Installation

Important: A Restraining Cable shall always be permanently attached to the appliance and wall directly behind the appliance when the Agent Distribution Hose is installed. Removal of this cable shall only occur when the Agent Distribution Hose is not installed to the appliance.

See Figure 17 for mounting the Restraining Cable to the wall. See Figure 18 for mounting the Restraining Cable to the back of an appliance.

RESTRAINING CABLE – WALL-MOUNTED OPTION

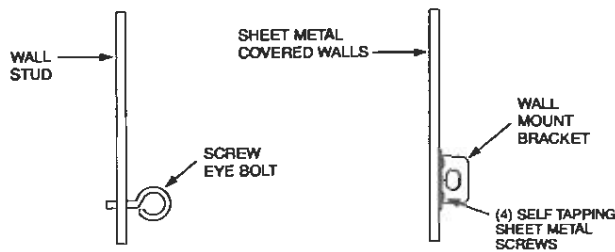

FIGURE 17
008098

RESTRAINING CABLE – APPLIANCE-MOUNTED OPTION

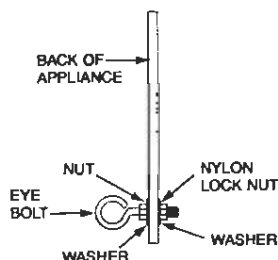

FIGURE 18
008099

RESTRAINING CABLE – HENNY PENNY-MOUNTED OPTION

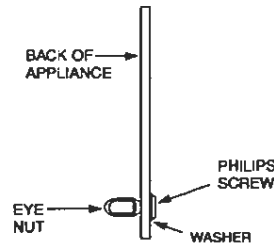

FIGURE 19
008090

1. The Restraining Cable must be connected from the appliance to the wall or some other structurally sound object capable of restraining the casted appliance from being able to be pulled or pushed out to a point that will result in strain or stress to the Agent Distribution Hose.
2. The Restraining Cable should be installed in line with the Agent Distribution Hose.
3. For sheet metal covered walls, the Restraining Cable Assembly includes four (4) 3/4 in. x #8 self tapping sheet metal screws, and a Restraining Cable Bracket. Securely attach the Restraining Cable Bracket to the sheet metal covered wall using the 3/4 in. x #8 self tapping metal screws provided.
4. For mounting to wall studs, the Restraining Cable Assembly includes one (1) screw eye lag bolt, 5/16 in. x 2.5 in. (6.4 cm) long.
5. Locate a structural area (frame) on the rear side of the equipment that is in line with the wall attachment. **Note:** It may be necessary to contact the appliance manufacturer for a suitable location. Drill a 5/16 in. (8 mm) diameter hole. Use caution when drilling hole, so that internal components are not damaged.
6. The Restraining Cable Assembly also includes a 5/16 in. threaded eye-bolt, 5/16 in. hex head nut, 5/16 in nylon lock nut, and two (2) 5/16 in. flat washers. Thread the included hex nut onto the eye-bolt. Slide one washer onto the eye-bolt threads next to the nut. Then, slide the eye-bolt through the drilled hole and place a washer and nylon locknut onto the eye-bolt on the inside frame of the equipment. Tighten securely.

**AGENT DISTRIBUTION HOSE INSTALLATION INSTRUCTIONS
 (Continued)**

Restraining Cable Installation (Continued)

7. Attach one of the snap hooks (included in the Restraining Cable package) on the end of the Restraining Cable to the wall bracket and the other snap hook to the eye-bolt (See Figure 20). After snap-hooking the assembly, seal the Restraining Cable Loops to the wall bracketry and appliance connection hardware with ANSUL Lead Wire Seal, Part No. 197.

Note: For the Henny Penny Pressure Fryers that utilize the ANSUL Henny Penny Fryer Nozzle Kit, Part No. 434455, the 5/16 in. philips screw supplied in the Henny Penny Fryer Nozzle Kit, the 5/16 in. eye nut, and 5/16 in. washer included in the Restraining Cable Assembly Kit, must be used. (See Figure 19).

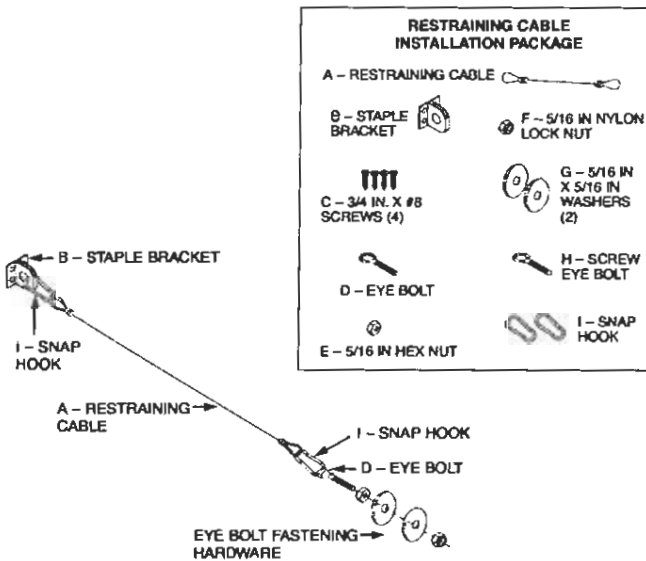

FIGURE 20
007820

Final Installation Guidelines and Checkout Procedures

After the Agent Distribution Hose and the Restraining Cable is properly installed, carefully push the appliance back to its normal operating position. Check that the hose does not have sharp bends, and is not kinked, twisted, or caught on anything behind the appliance.

1. Verify the Restraining Cable limits the travel of the appliance and prevents the application of any pull force or bending stress on the Agent Distribution Hose or hose-to-pipe connections.
2. Make certain there are no sharp bends and kinks in the hose when pulling out the cooking equipment.
3. The Agent Distribution Hose should always be in a vertical natural loop, never having any bends greater than a 3 in. (7.6 cm) radius (6 in. (15.2 cm) diameter), hose twists, or sharp bends. (See Figure 21.) If any of these conditions exist, the hose and/or hose connections will require installation modifications.

SIDE VIEW

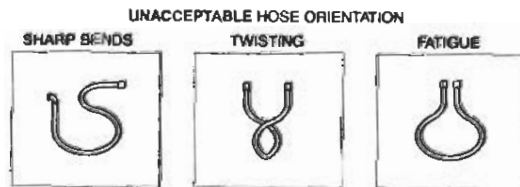
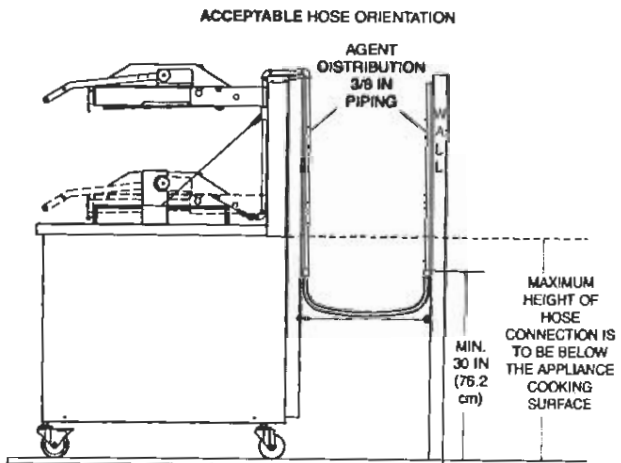

FIGURE 21
007830

4. Return the appliance to its normal operating position in accordance with NFPA 96. Means shall be provided to verify that the appliance returns to its original designed positioning. Failure to do so may result in undue stress and fatigue of the hose and hose connections.

NOTES:

INSTALLING THE DETECTION SYSTEM

Before the following procedures can be completed, the detection design must already be completed. These installation instructions are identical for single, double, and multiple-tank systems except for the number of hazard areas to be covered.

NOTICE

Inform customer that fusible links should not be exposed to ammonia-based chemical cleaners or steam.

1. Based on the requirements listed in the "System Design" section, mount the detectors in their predetermined locations.
2. Run 1/2 in. conduit from the regulated release mechanism trip hammer assembly knockout hole to locations selected for mounting the detectors.

Note: Before assembling the conduit and fittings, make certain all ends are carefully reamed and blown clear of chips and scale. Inside of pipe and fittings must be free of oil and dirt.

When changing the direction of conduit, use only ANSUL pulley elbows, except, at the top of the regulated release, it is acceptable to use the "Conduit Offset Assembly" (Part No. 436063).

Note: If stainless steel scissor linkage is used in the system while using conduit off-set assembly, the following limitations must be observed:

- Maximum number of elbows – 16
- Maximum number of detectors – 15
- Maximum length of 1/2 in. EMT Conduit – 150 ft (45.7 m)

Part No. 435546 and 435547 are the "scissor" style series and terminal detector assemblies. These detector assemblies use a detector linkage assembly which does not require the wire rope to be threaded through the linkage assembly while it is being fed through the detection system.

"Scissor" Style Linkage Installation

1. Secure the conduit to the detector bracket using the two 1/2 in. steel compression fittings on the series detector bracket or the single 1/2 in. steel compression fitting on the terminal detector bracket. See Figure 22.

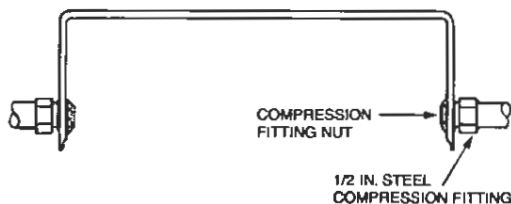
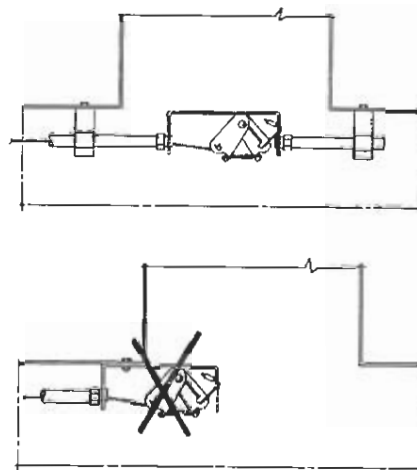

FIGURE 22
000308

NOTICE

Do not use zinc die cast compression connectors on the detection conduit lines as these will not withstand the normally high temperatures experienced in the plenum area.

2. For a terminal detector located in a duct or header opening, secure both sides of the detector bracket with conduit, as shown in Figure 23.



002463

002464

FIGURE 23

INSTALLING THE DETECTION SYSTEM (Continued)

“Scissor” Style Linkage Installation (Continued)

3. Starting at the release assembly, feed the wire rope through the hole in the release mechanism locking clamp, allowing the excess wire rope to hang down. (Do not tighten set screws in locking clamp at this time.) See Figure 24.

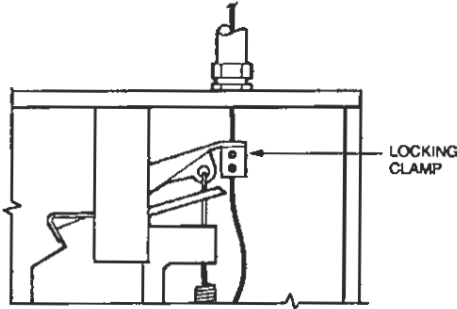

FIGURE 24
000309

4. From the release assembly, run the stainless steel wire rope through the conduit, pulley elbows and detector brackets to the terminal detector.

NOTICE

If wire rope requires splicing, make certain splice is at least 12 in. (30.5 cm) away from any pulley elbow or conduit adaptor to avoid interference.

5. Feed the wire rope through the terminal detector bracket as shown in Figure 25 or as shown in Figure 26 if the terminal detector is mounted within a duct or header opening, and install the stop sleeve approximately 2 to 3 in. (5 to 8 cm) from the end of the wire rope. See Figure 27. Use the National Telephone Supply Company Nicopress Sleeve Tool (Stock No. 51-C-887) or equal to properly crimp the stop sleeve.

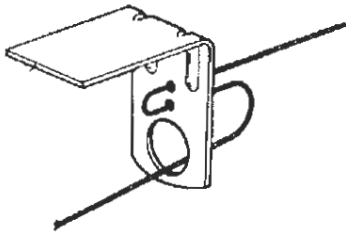

FIGURE 25
000310

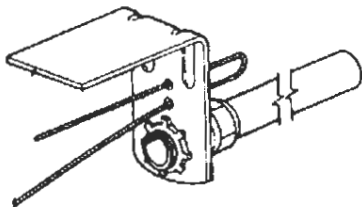

FIGURE 26
000311



FIGURE 27
000312

6. To give a constant tension on the wire rope during installation of the detector linkage, hang a vice grip or other weighted device on the excess stainless steel wire rope, leaving an adequate length of spare wire rope between the locking clamp and the weighted device.

NOTICE

When attaching the weighted device to the excess wire rope, allow approximately 3 in. (8 cm) of wire rope for each detector linkage for proper installation.

Example: If the system has six detectors, there should be approximately 18 in. (46 cm) of excess wire rope between the locking clamp and the weighted device, which will be utilized when the linkage is put in place.

7. Install detector scissor assembly as shown in Figure 28. Note that the ANSUL AUTOMAN or remote release assembly is located on the left side of the detector bracket. Slightly crimp the two assembly “boot-hooks” over the cable with pliers so the cable is captured under each hook but the whole assembly can move from side to side. Center the assembly in the detector bracket.

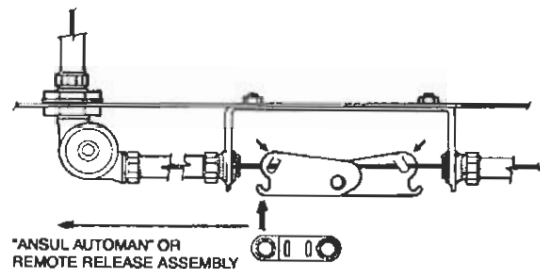

FIGURE 28
000503

INSTALLING THE DETECTION SYSTEM (Continued)
“Scissor” Style Linkage Installation (Continued)

- ▶ 8. Hook the fusible link on the ANSUL AUTOMAN or remote release assembly side of the hook assembly, then pull the fusible link to the opposite side and complete the hookup as shown in Figures 29 and 30. The top of the hook assembly must be inside the bracket stiffeners. The hook assembly with the ANSUL fusible link in place must be located toward the terminal detector side of the bracket.

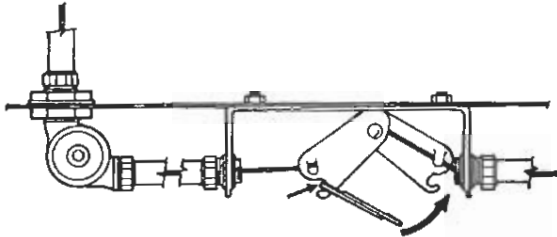

FIGURE 29
000504

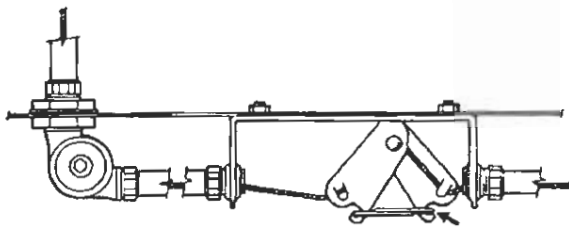

FIGURE 30
000324

- ▶ 9. Install the linkage and the correct ANSUL approved fusible link in the remainder of the detector brackets. Make certain all detector linkages are positioned against either the front or back upper lip of the formed detector bracket. See Figure 30a.

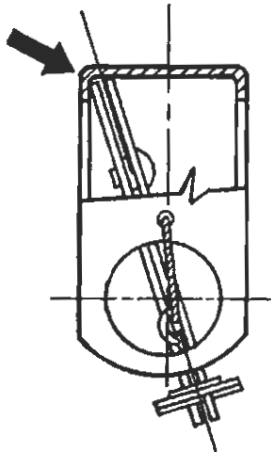

FIGURE 30a
004429

- ▶ 10. Insert cocking lever (Part No. 14995 or Part No. 435603) on left side of the release mechanism, with the movable flange resting securely against the corner of the cartridge receiver and spring housing, and with the notched lever portion engaging the cocking pin on both sides of the release mechanism. See Figure 31.

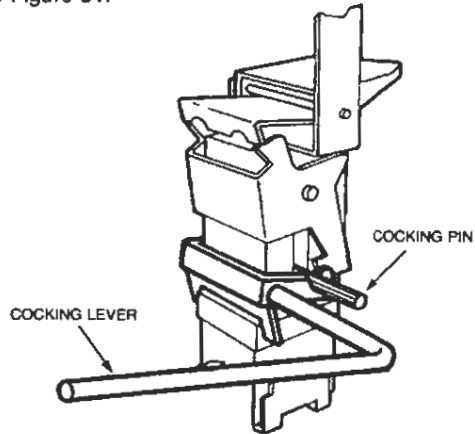

FIGURE 31
000319

- ▶ 11. Using long handle cocking lever, Part No. 14995, or wrench on short handle cocking lever nut, Part No. 435603, pull down to raise cocking pin until the trip lever indented surface moves underneath the pin and locks the pin in the up position. See Figure 32.

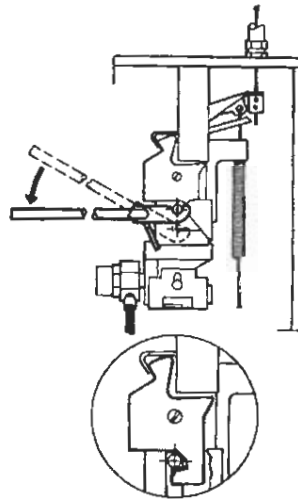

FIGURE 32
000320

INSTALLING THE DETECTION SYSTEM (Continued)

"Scissor" Style Linkage Installation (Continued)

12. Remove cocking lever and insert lock bar (Part No. 14985) on left side of the cable lever, over the two shouldered projecting stud extensions, and slide bar forward into locking position. (The release mechanism cannot be actuated, nor can enclosure cover be replaced until the lock bar is removed.) See Figure 33.

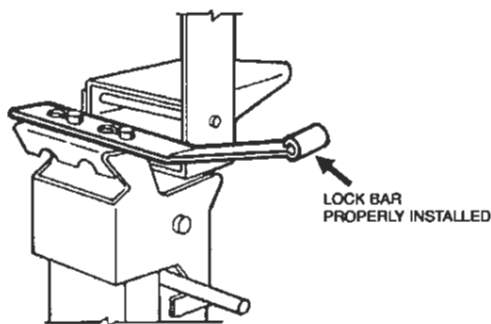

FIGURE 33
000321

13. Make certain tension lever is in the "UP" position. See Figure 34.

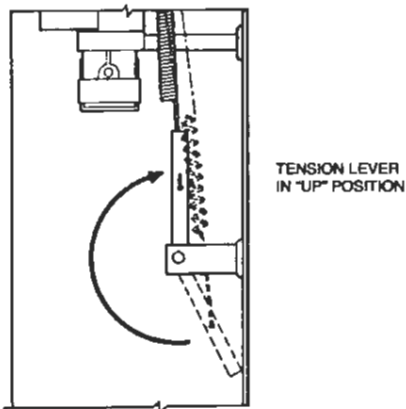

FIGURE 34
000322

14. Verify each detector linkage assembly, with correct fusible link, is in the detector bracket, located fully toward the terminal detector side.

NOTICE

Due to the close adjustment between the trip hammer and cable lever assemblies, use only the particular fusible link(s) selected for installation in each detector, including terminal detector, to ensure correct adjustment when performing Steps 15 and 16.

15. Raise trip hammer 3/8 in. to 1/2 in. (9.5 to 12.7 mm), pull all slack out of wire rope, and tighten set screws on locking clamp.

16. Lower tension lever to "DOWN" position and inspect the base of the wire rope locking clamp to make certain that there is a minimum of 1/4 in. (6.4 mm) and a maximum of 3/8 in. (9.5 mm) clearance between the base of the trip hammer locking clamp assembly and the cable lever assembly. See Figure 35. (If clearance is not between 1/4 in. (6.4 mm) or 3/8 in. (9.5 mm), raise tension lever, loosen set screws on locking clamp and repeat Steps 15 and 16.)

CAUTION

Make certain the hook assembly with the ANSUL fusible link in place is located toward the terminal detector side of each bracket. Failure to do so may restrict travel of detection line, causing system to malfunction.

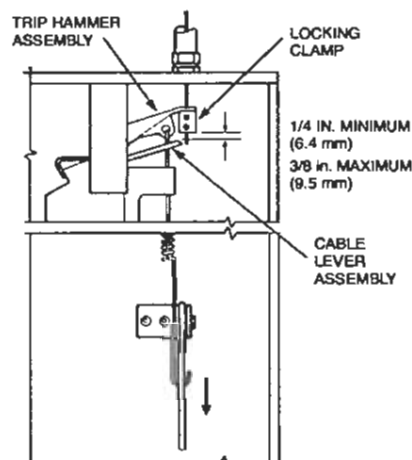

FIGURE 35
000323

CAUTION

Do not install cartridge at this time as an accidental actuation could cause system discharge.

17. Test detection system in accordance with the Testing and Placing in Service Section, Page 7-1 – 7-3, of this manual.
18. When testing has been completed, cut off excess wire rope in the regulated release assembly, leaving approximately 2 in. (5.1 cm) of wire rope below the locking clamp.

INSTALLING REMOTE MANUAL PULL STATION

▶ GENERAL INSTALLATION REQUIREMENTS

To install a remote manual pull station complete the following steps:

1. Make certain that regulated release assembly enclosure cover is detached and lock bar is properly inserted within the regulated release mechanism.

NOTICE

Failure to follow these instructions may lead to system actuation.

2. Verify that cartridge has been removed from regulated release assembly and that the regulated release assembly is in the cocked position.

If regulated release assembly does not have lock bar inserted or cartridge removed, refer to the "Semi-Annual Maintenance," Page 8-1, in "Maintenance Examination" section, and complete Steps 2 and 3 before completing the following installation steps.

3. Select a convenient location in the path of egress for mounting the pull station(s) to the wall. The pull station should be installed at a height of 42 in. to 48 in. (107 cm to 122 cm) in accordance with the authority having jurisdiction and the American Disabilities Act (ADA) requirements.

A maximum of two (2) manual pull stations can be connected to each AUTOMAN Release.

▶ INSTALLATION FOR REMOTE MANUAL PULL STATION UTILIZING EMT CONDUIT ONLY

1. The total length of the wire rope used for each manual pull station within a system must not exceed 150 ft (46 m).

The maximum number of pulley elbows that may be used per each manual pull station is 20 of Part No. 423250 or 415670.

2. If junction box(es) is used, fasten a 4 in. (10 cm) junction box to wall or in wall where pull station is to be mounted, with mounting screws positioned so that when pull station cover is positioned in place, the printing will appear right side up and readable.

3. Install and secure 1/2 in. conduit, pulley tee (if required), and pulley elbows from each pull station junction box to regulated release assembly as necessary. See Figure 36.

See Figures 36a, 36b, and 36c for optional methods of installing wire rope when utilizing a pulley tee, Part No. 427929.

REMOTE MANUAL PULL STATION SINGLE APPLICATION

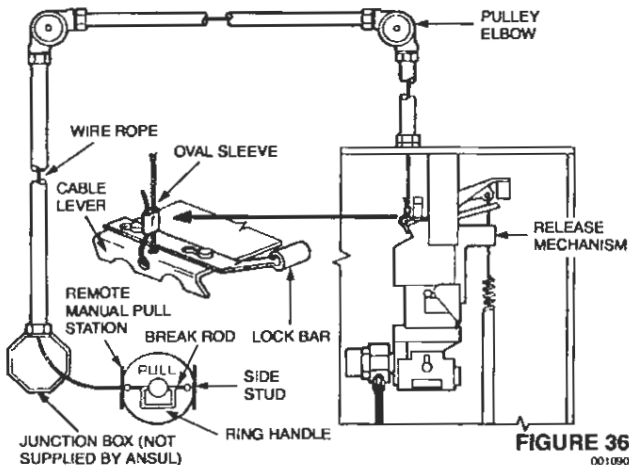

REMOTE MANUAL PULL STATION DUAL APPLICATION – OPTION 1 (ONE (1) WIRE ROPE CONNECTED TO CABLE LEVER ASSEMBLY)

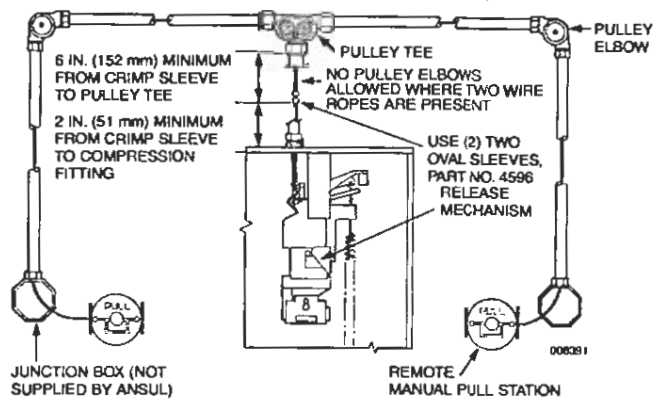

FIGURE 36a

REMOTE MANUAL PULL STATION DUAL APPLICATION – OPTION 2 (TWO (2) WIRE ROPES CONNECTED TO CABLE LEVER ASSEMBLY)

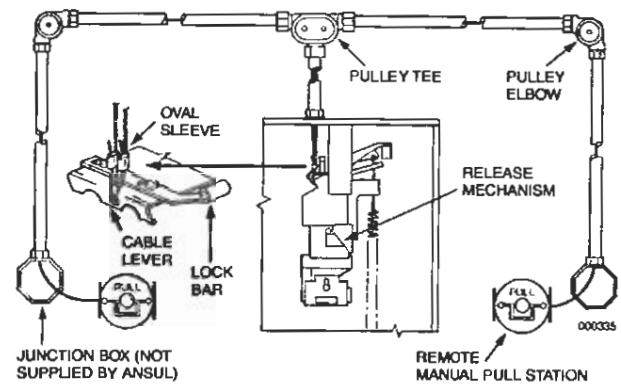

FIGURE 36b

REMOTE MANUAL PULL STATION APPLICATION – OPTION 3

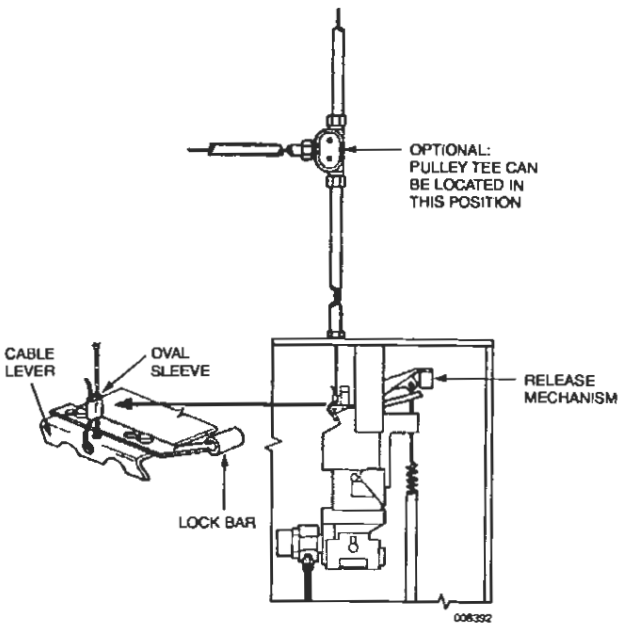

FIGURE 36c

INSTALLING REMOTE MANUAL PULL STATION (Continued)
INSTALLATION FOR REMOTE MANUAL PULL STATION
UTILIZING EMT CONDUIT ONLY (Continued)

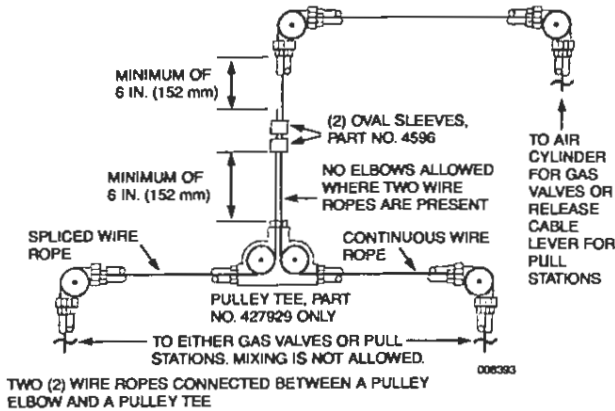

FIGURE 36d

4. Feed wire rope from the ANSUL AUTOMAN release through conduit and pulley elbows and pulley tee, if provided, to the pull station junction box. Follow the instructions for assembling the pull station and block assembly and attaching the wire rope to the pull station pull knob (see Figures 64 through 79).

NOTICE

Make certain that wire rope rides on top and in center of pulley sheave. If the 50 ft (15 m) wire rope has been spliced to accommodate a longer run, do not allow the spliced ends to be within 6 in. (152 cm) of any pulley elbow or conduit adaptor.

- ▶ 5. Fasten pull station assembly to each junction box (if junction box is used).
- ▶ 6. Slide oval crimp sleeve onto wire rope. Loop wire rope through cable lever guide holes and back through the oval crimp sleeve. See Figure 36.
- ▶ 7. Pull slack out of each wire rope and crimp sleeve. (Use the National Telephone Supply Company Nicopress Sleeve Tool Stock No. 51-C-887 or equal to properly crimp stop sleeve.) See Figure 36.

▶ **Note:** When utilizing flexible conduit for remote manual pull station or mechanical gas valve installation, refer to "Installation of Remote Manual Pull Station or Mechanical Gas Valve Utilizing Flexible Conduit" instructions on pages 5-17 through 5-17.11.

INSTALLING MECHANICAL GAS VALVE

NOTICE

Mechanical gas valves are designed for indoor installation only.

To install each Mechanical Gas Shut-off Valve complete the following steps. (All gas valve installation and testing shall be made in accordance with the authority having jurisdiction.)

Note: Mechanical gas valve air cylinder(s) can be installed in regulated release assemblies and also regulated actuator assemblies. Installation in either is the same.

1. Make certain that regulated release assembly enclosure cover is detached and lock bar is properly inserted in the regulated release mechanism.

NOTICE

Failure to follow these instructions may lead to system actuation.

2. Verify that cartridge has been removed from regulated release assembly and that the regulated release mechanism is in the cocked position.

If regulated release mechanism does not have lock bar inserted or cartridge removed, refer to the "Semi-Annual Maintenance," Page 8-1, in "Maintenance Examination" section, and complete Steps 2 and 3 before completing the following installation steps.

- ▶ 3. Remove plug from cartridge receiver. See Figure 37.

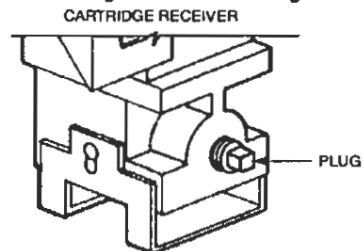

FIGURE 37
00039

- ▶ 4. Locate air cylinder and bracket assembly over the two 7/32 in. (0.6 cm) holes on right side of the enclosure. Assemble with screws, lockwashers, and nuts. Wrench tighten. See Figure 38. Air cylinder(s) can also be mounted in the inverted position, allowing for direct exit out the knockout(s) in the bottom of the enclosure. See Figure 39.

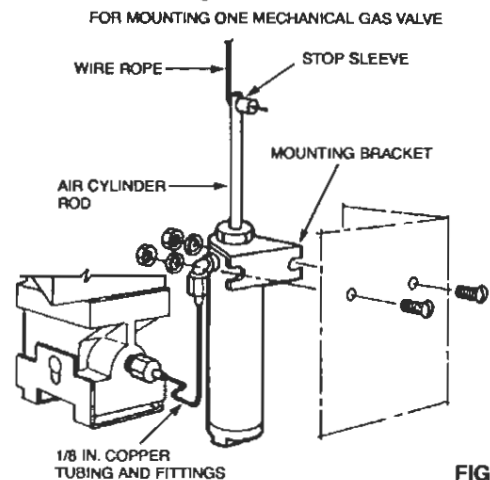

FIGURE 38
000340

SECTION V – INSTALLATION INSTRUCTIONS

UL EX3470 ULC EX3470 Page 5-14
 REV. 3 7-1-09

INSTALLING MECHANICAL GAS VALVE (Continued)

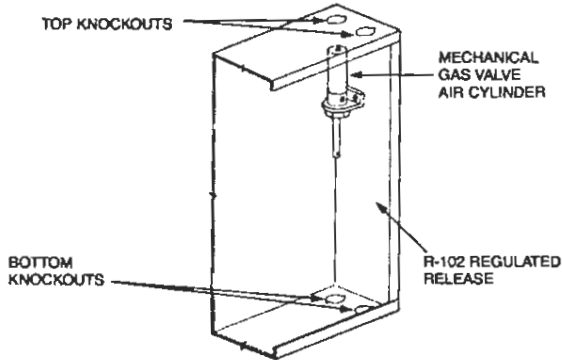

FIGURE 39
000341

Note: Two air cylinders are necessary only if the old style pulley tee, Part No. 15342, is utilized. If new style pulley tee, Part No. 427929, is utilized, only one air cylinder is required. Individual wire ropes can be run from each gas valve to a single air cylinder. See Figure 40.

- To install second mechanical gas valve shut-off system, locate second air cylinder and bracket assembly adjacent to first assembly and over the two remaining 7/32 in. (.6 cm) holes provided on right side of the enclosure. Assemble second cylinder with screws, lockwashers, and nuts as required. Wrench tighten. See Figure 40.

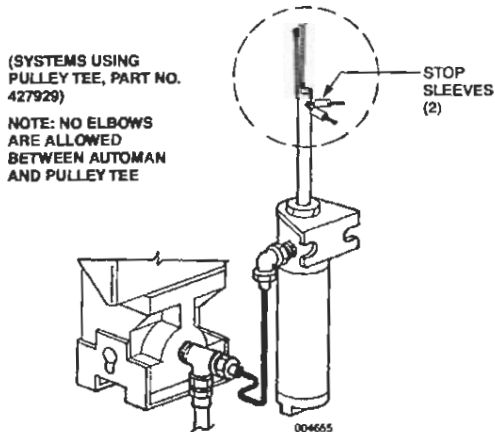
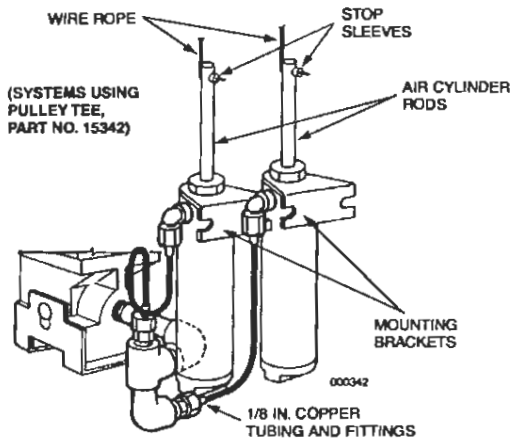

FIGURE 40
000342

INSTALLING MECHANICAL GAS VALVE (Continued)

6. Install the necessary 1/8 in. copper tubing and fittings for each air cylinder to the accessories piping arrangement on the regulated release mechanism. See Figures 38 and 40.

NOTICE

Do not kink 1/8 in. copper tubing or form a bend too close to a fitting. Secure each fitting without over tightening. Over tightening could result in pressure leakage or line separation at actuation.

7.

⚠
CAUTION

To reduce the risk of explosion due to leaking gas, make certain that the gas line is turned off before connecting the gas valve. Gas valve installation shall be performed by qualified individuals in accordance with local jurisdiction requirements.

Install mechanical gas valve to its selected location in gas line so that it ensures safe shut-off to all predetermined appliances being protected upon actuation of the system. Mechanical gas valves may be mounted in any convenient horizontal or vertical position. See Figure 41.

- a. Use new pipe, properly reamed and cleaned of metal chips.
- b. Make certain gas flow is in the same direction as arrow shown on gas valve. To avoid cracking the gas valve casting, do not overtighten pipe connections. If pipe tape, paste, spray, or similar lubricant is used, extra care should be taken to avoid overtightening. Apply lubricant to male threads only.
- c. Wrench tighten pipe to gas valve. **DO NOT USE GAS VALVE AS A LEVER WHEN INSTALLING OR VALVE DAMAGE MAY OCCUR.** See Figure 41.
- d. If strainer is utilized, attach strainer ahead of gas valve.
- e. If necessary, install drip leg in gas line in accordance with the authority having jurisdiction.
- f. The total length of wire rope allowed for each valve must not exceed 150 ft (46 m).
- g. The maximum number of pulley elbows allowed for each gas valve is 20.

ANSUL MECHANICAL GAS VALVES

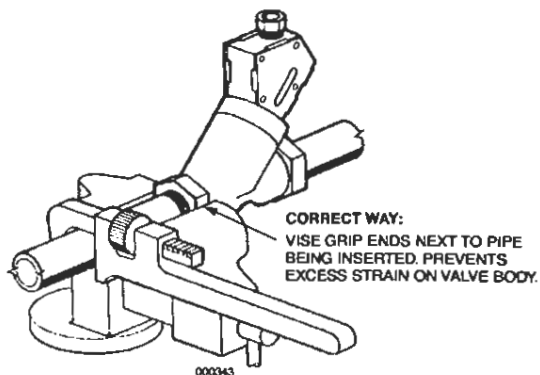

CORRECT WAY:

WRENCH APPLIED NEXT TO PIPE BEING INSERTED PREVENTS EXCESS STRAIN ON VALVE BODY.

WRONG WAY:
WRENCH APPLIED AT THIS POINT STRAINS VALVE BODY.

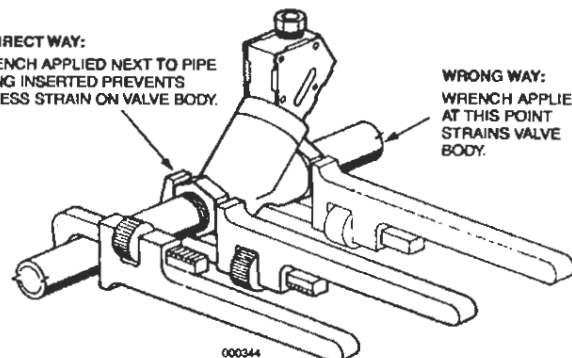

ASCO MECHANICAL GAS VALVES

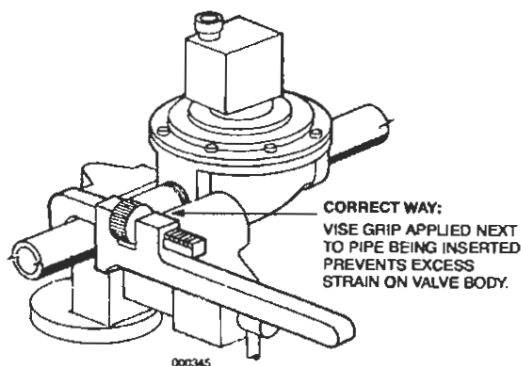

CORRECT WAY:

WRENCH APPLIED NEXT TO PIPE BEING INSERTED. PREVENTS EXCESS STRAIN ON VALVE BODY.

WRONG WAY:
WRENCH APPLIED AT THIS POINT STRAINS VALVE BODY.

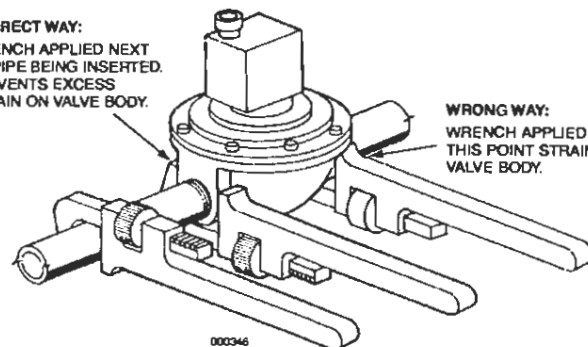

FIGURE 41

INSTALLING MECHANICAL GAS VALVE (Continued)

8. Install 1/2 in. conduit, and pulley elbow(s) from the mechanical gas valve to regulated release assembly enclosure as necessary.
9. Beginning at the regulated release assembly, thread the end of the wire rope through hole provided in air cylinder rod. See Figure 38.
10. Feed end of wire rope through conduit and each pulley elbow.
 Make certain that wire rope rides on top and in center of pulley sheave. If the 50 ft (15 m) wire rope has been spliced to accommodate a longer run, do not allow the spliced ends to be within 12 in. (30 cm) of any pulley elbow or conduit adaptor.
11. Remove side cover on gas valve and thread end of wire rope through hole in cocking lever. Slide stop sleeve (Part No. 26317) on to wire rope and crimp. (Use the National Telephone Supply Company Nicopress Sleeve Tool Stock No. 51-C-887 or equal to properly crimp stop sleeve.) Make certain crimp is on top of trigger, with wire rope curled under lever. See Figure 42.

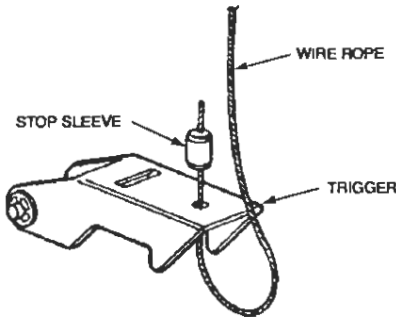
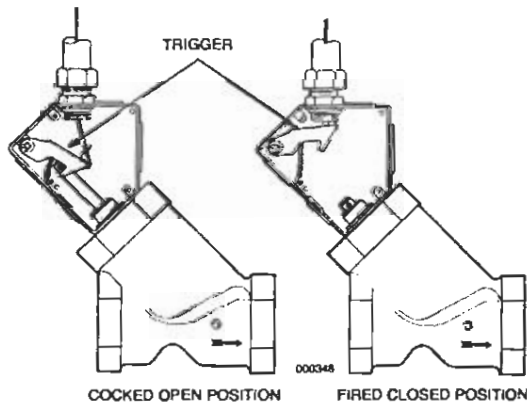

FIGURE 42
000347

12. With the end of wire rope already threaded through hole in air cylinder rod, slide stop sleeve (Part No. 26317) onto wire rope and leave loose. Do not crimp stop sleeve at this time. See Figure 38.
13. Cock mechanical gas valve as shown in Figure 43. **Note:** A valve cocking tool is available. Order Part No. 416018.

ANSUL MECHANICAL GAS VALVE



ASCO MECHANICAL GAS VALVE

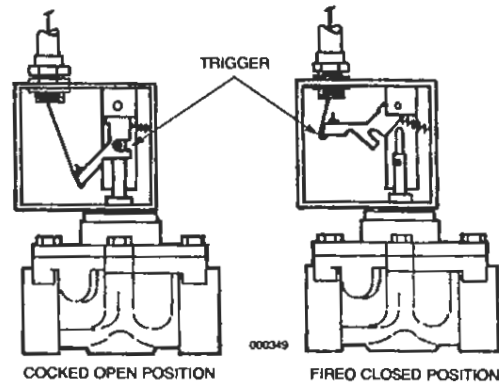

FIGURE 43

14. Raise air cylinder rod "UP" to its maximum extended position. See Figure 38.
 15. Manually pull wire rope to remove excess slack.
- NOTICE**
 DO NOT ACTUATE THE MECHANICAL GAS VALVE. Each Mechanical Gas Valve System must have gas valve cocked and air cylinder rod extended "UP" to its maximum extension before completing next step.
16. Slide stop sleeve against air cylinder rod, make certain all slack is removed from wire, and crimp stop sleeve. See Figure 38.
 17. Cut off any excess wire rope approximately 3/4 in. (2 cm) from end of stop sleeve.
 18. **Note:** If utilizing a pulley tee to operate either a single mechanical gas valve from two (2) ANSUL AUTOMAN releases or two (2) mechanical gas valves from one (1) air cylinder in an ANSUL AUTOMAN release, see Figures 44 and 45 for installation instructions. Maximum length of wire rope to each ANSUL AUTOMAN release must not exceed 150 ft (45.7 m) and maximum number of elbows must not exceed 20.

TWO (2) AIR CYLINDERS – ONE (1) MECHANICAL GAS VALVE

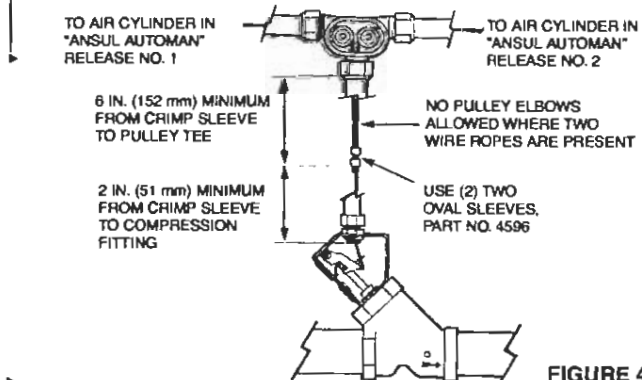

FIGURE 44
001091

INSTALLING MECHANICAL GAS VALVE (Continued)

ONE (1) AIR CYLINDER – TWO (2) MECHANICAL GAS VALVES

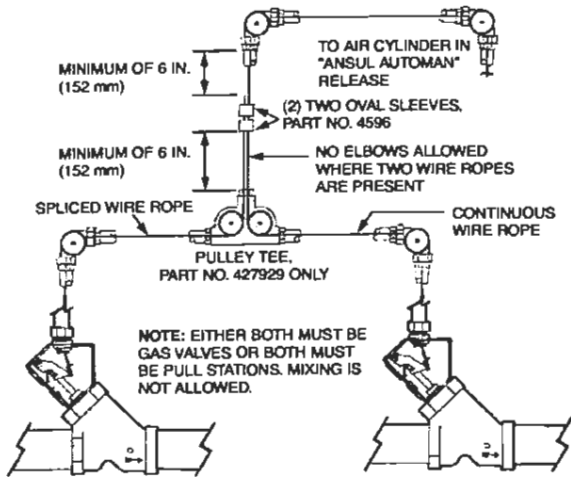

FIGURE 45
008394

NOTICE

When connecting two (2) mechanical gas valves to one (1) air cylinder, make certain both gas valves properly operate (close) when the air cylinder rod is in the down (operated) position.

INSTALLATION OF REMOTE MANUAL PULL STATION OR MECHANICAL GAS VALVE UTILIZING FLEXIBLE CONDUIT

Flexible conduit allows for quicker installations and the convenience of being able to route the cable over, under and around obstacles.

Flexible conduit can be used as a substitute for standard EMT conduit or can be used with EMT conduit.

NOTICE

Flexible conduit can be used only with NEW remote pull station, Part No. 434618, and mechanical gas valve installations. Flexible conduit CAN NOT be used in detection systems.

These instructions address the components and installation of both the pull station, Part No. 434618, and the flexible conduit.

Design Requirements

- Flexible conduit cannot be utilized in detection systems.
- Flexible conduit inserts, Part No. 434347, can ONLY be used with the flexible conduit system.
- The maximum distance from an ANSUL AUTOMAN® Release to a Pull Station, Part No. 434618, is 140 ft (42.7 m) with a maximum of 360° (for example, 3-90° and 2-45° bends, 2-90° and 4-45° bends, etc.) bends in the flexible conduit, one pulley tee (refer to pages 5-17.9 through 5-17.11 for detailed splicing instructions), two splices, and 15 pulley elbows.

Note: When installing flexible conduit, make sure to feed wire rope through conduit directly from the spool. DO NOT pre-cut wire rope. Feeding pre-cut rope through flexible conduit will cause excessive kinks in the rope, making it difficult to install.

- The maximum distance from an ANSUL AUTOMAN Release to a mechanical gas valve is 75 ft (22.9 m) with a maximum of 4-90° bends in the flexible conduit and 4 pulley elbows.
- Any portion of the flexible conduit system can be substituted with EMT conduit provided the proper connections are used to join the two types of conduit.
- All bends in the flexible conduit system must have a minimum bend diameter of 6 in. (15 cm).
- When the flexible conduit is used to make 90° bends between an ANSUL AUTOMAN release and a mechanical gas valve, the bends must start at the gas valve. No pulley elbows can be used between the bends. If more than 360° of bends are needed, then pulley elbows can be used.
- When the flexible conduit is used to make 90° bends between an ANSUL AUTOMAN release and a pull station, the bends must start at the ANSUL AUTOMAN release. No pulley elbows can be used between the bends. If more than 360° of bends are needed, then pulley elbows can be used.
- When not utilizing a conduit offset, Part No. 79825, 2-45° bends in the flexible conduit are allowed between the strain relief fitting on top of the ANSUL AUTOMAN release, and the location where the flexible conduit is supported.
- When installing flexible conduit, conduit should be secured at intervals not to exceed 5 ft (1.5 m) and before and after each bend. Flexible conduit CANNOT slide in the clamp(s) used for mounting. Make certain mounting clamp(s) do not pinch the conduit. The following style clamp ('P' clip), Part No. 436150, is a suitable type for use on flexible conduit.

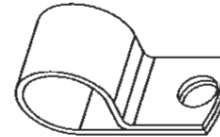

008141

TABLE 1

	Manual Pull	Mechanical Gas Valve	Detection
90° Cable Bends	4	4	N/A
Bend Diameter – in. (cm)	6 (15.2)	6 (15.2)	N/A
Mechanical Corner Pulley	15	4	N/A
Conduit Secured Max. ft (m)	5 (1.5)	5 (1.5)	N/A
Conduit Max. Length ft (m)	140 (42.7)	75 (22.9)	N/A
Conduit Offset or 2-45° Bends (Only between the strain relief fitting and support location)	1	0	N/A
Pulley Tees	1	0	N/A
Splices	2	0	N/A

INSTALLATION OF REMOTE MANUAL PULL STATION OR MECHANICAL GAS VALVE UTILIZING FLEXIBLE CONDUIT (Continued)

Installation Instructions

Note: Do not add any type of lubricants inside or on the flexible conduit. Make certain stainless steel wire rope is clean and debris-free.

The flexible conduit should be routed along the same path that EMT conduit would normally be run. Stainless steel wire rope should be routed through the flexible conduit as it is in EMT conduit.

 **CAUTION**

Flexible conduit must not be located within 6 in. (15 cm) of the hood or in areas exceeding 130 °F (54 °C). Also, do not route flexible conduit in areas where conduit can be crushed, pinched, or broken.

Flexible conduit can be used to connect an ANSUL AUTOMAN Release to a remote pull station, Part No. 434618, or mechanical gas valves.

Before starting the system installation, take a few minutes to plan the layout of the system. This will minimize the amount of components needed to complete the installation. Once the path of the flexible conduit has been determined, verify that the layout does not exceed the design requirements.

Connecting the Flexible Conduit to the ANSUL AUTOMAN Release, Electrical Junction Box, or MECHANICAL Gas Valve

1. Layout the flexible conduit and secure it in place. **Note:** If inner liner is crimped, turn a drywall screw into the end to open it. See Figure 46.

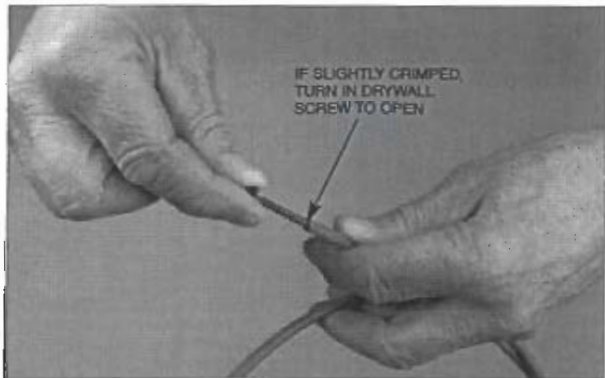

FIGURE 46
007985

2. Starting at the ANSUL AUTOMAN Release, connect the conduit connector using the supplied nut. Use only ANSUL conduit fittings, Part No. 55813. See Figure 47.

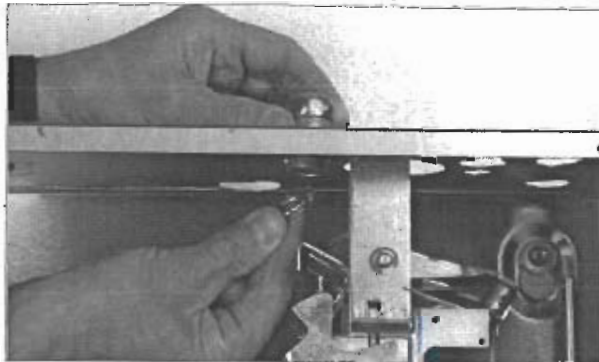

FIGURE 47
007988

3. Unscrew the nut from the EMT conduit connector and remove the compression ring. Discard ring. See Figure 48.

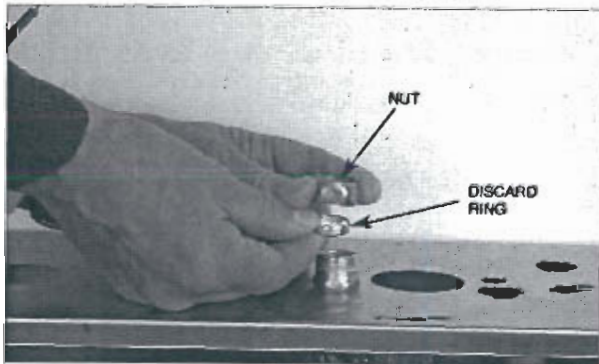

FIGURE 48
007987

4. Thread the stainless steel wire rope through the EMT conduit connector and flexible conduit insert. Make certain thread in flexible conduit insert is facing out toward end of connector. See Figure 49.

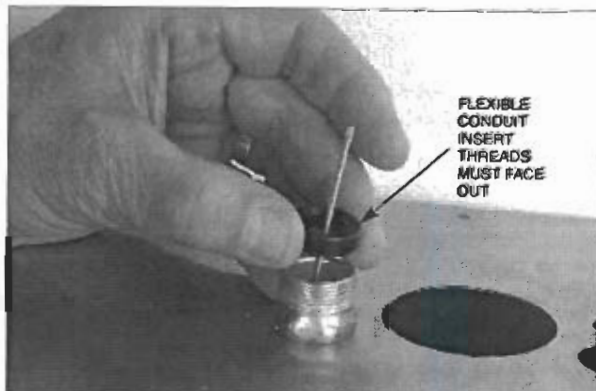

FIGURE 49
007986

INSTALLATION OF REMOTE MANUAL PULL STATION OR MECHANICAL GAS VALVE UTILIZING FLEXIBLE CONDUIT (Continued)

Connecting the Flexible Conduit to the ANSUL AUTOMAN Release, Electrical Junction Box, or Mechanical Gas Valve (Continued)

5. Tighten the nut to the connector body, locking the flexible conduit insert in place. See Figure 50.

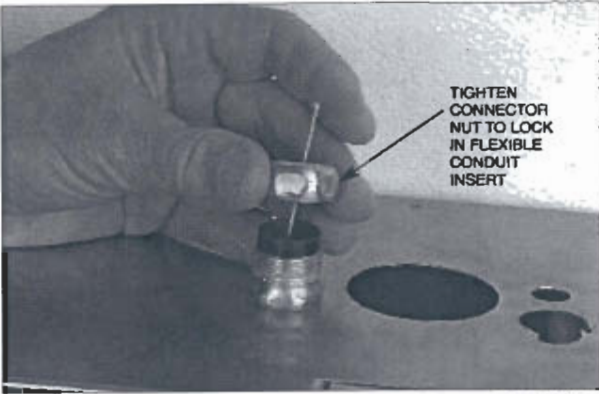

FIGURE 50
007989

6. Loosen the nut on the strain relief and thread the wire rope through a strain relief. See Figure 51.

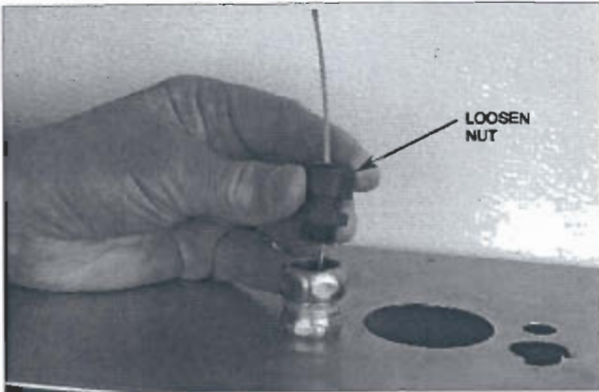

FIGURE 51
007990

7. Tighten the body of the strain relief to the conduit connector. See Figure 52.

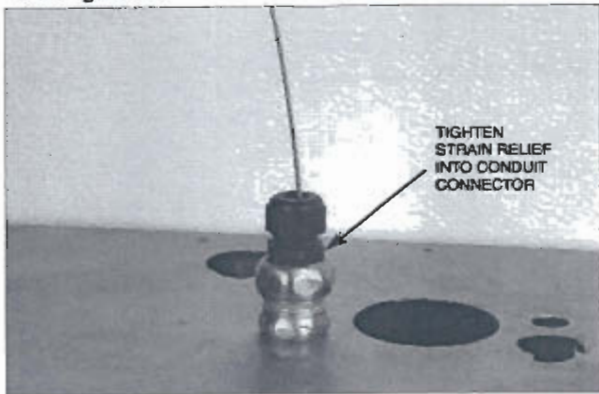

FIGURE 52
007991

8. Thread the wire rope through the flexible conduit. See Figure 53. (If a splice is required in the flexible conduit, proceed to "Splicing Installation Instructions.")

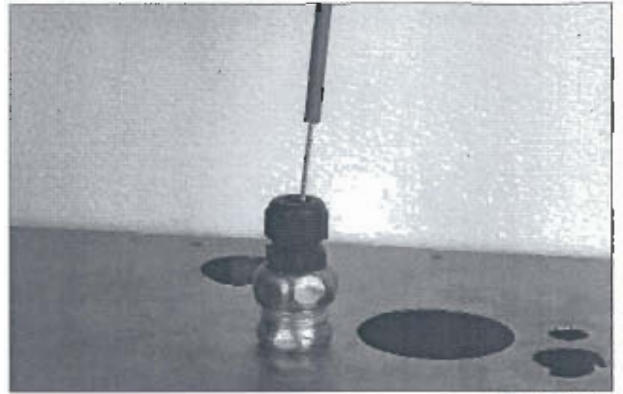

FIGURE 53
007992

9. Slide the flexible conduit into the strain relief until it is approximately 1/16 in. (2 mm) from the bottom of the flexible conduit insert. See Figure 54.

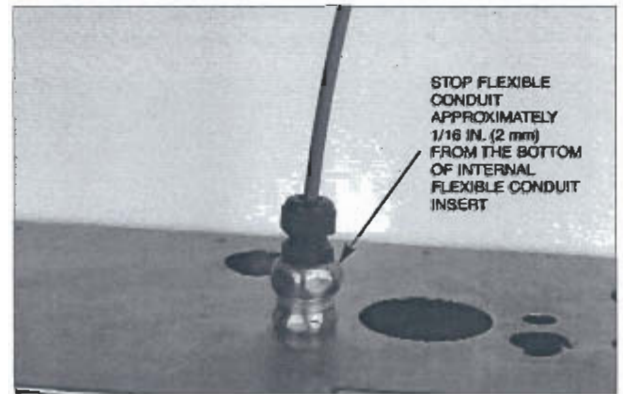

FIGURE 54
007993

10. Tighten the strain relief nut onto the strain relief. See Figure 55.

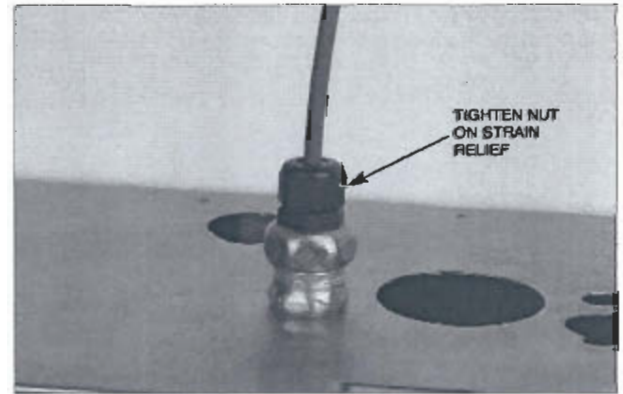

FIGURE 55
007994

INSTALLATION OF REMOTE MANUAL PULL STATION OR MECHANICAL GAS VALVE UTILIZING FLEXIBLE CONDUIT (Continued)

Connecting Flexible Conduit to Pulley Elbows, Pulley Tees, or Union Fittings

1. Unscrew the nut from pulley elbow, pulley tee, or EMT conduit connector and remove the compression ring. Discard ring. See Figure 56.

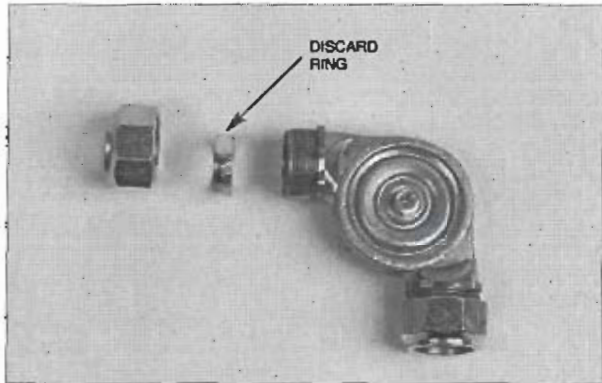

FIGURE 56
007996

2. Thread the stainless steel wire rope through the EMT conduit connector and flexible conduit insert. Make certain thread in flexible conduit insert is facing out toward end of connector. See Figure 57.

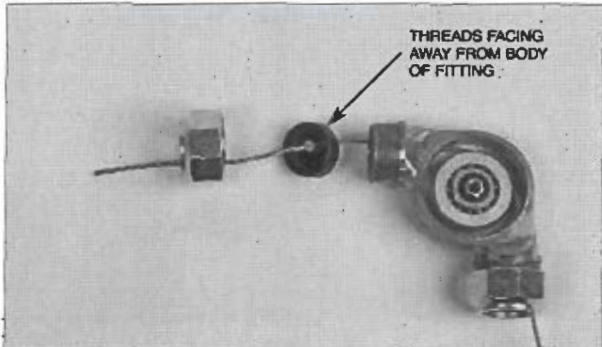

FIGURE 57
007996

3. Tighten the nut to the connector conduit body, locking the flexible conduit insert in place. See Figure 58.

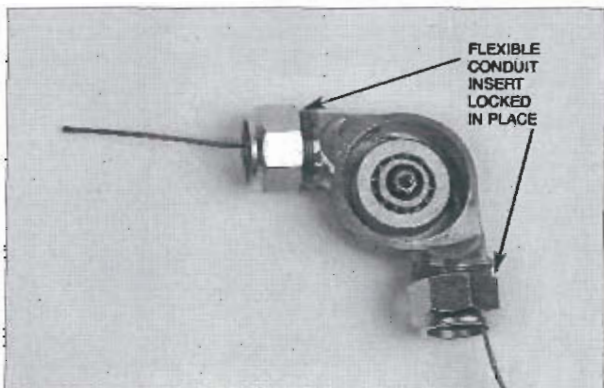

FIGURE 58
007997

4. Loosen the nut on the strain relief and thread the wire rope through the strain relief. See Figure 59.

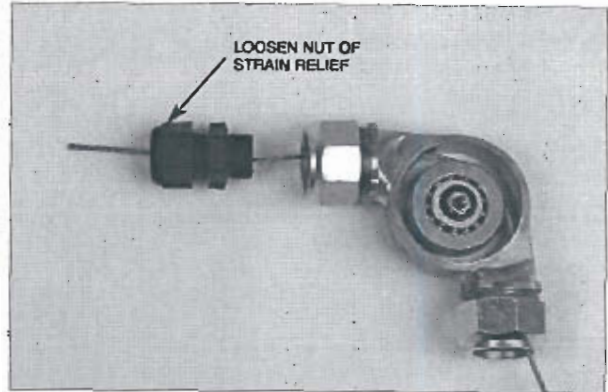

FIGURE 59
007998

5. Tighten the body of the strain relief to the conduit connector. See Figure 60.

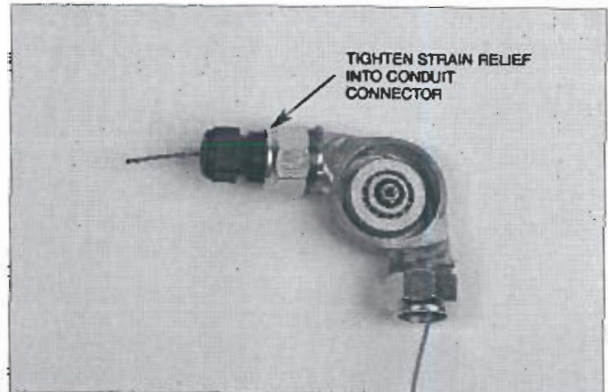

FIGURE 60
007998

6. Push the wire rope into the flexible conduit. See Figure 61.

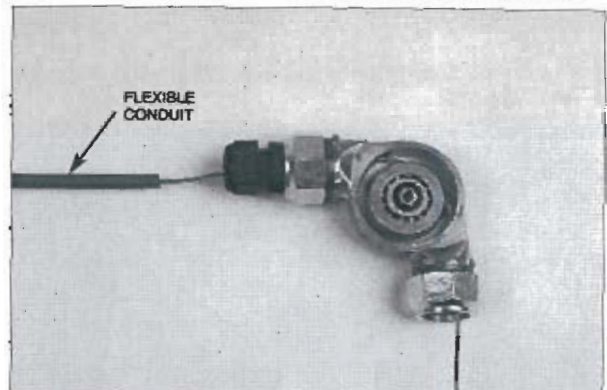

FIGURE 61
008000

INSTALLATION OF REMOTE MANUAL PULL STATION OR MECHANICAL GAS VALVE UTILIZING FLEXIBLE CONDUIT (Continued)

Connecting Flexible Conduit to Pulley Elbows, Pulley Tees, or Union Fittings (Continued)

7. Slide the flexible conduit into the strain relief until it is approximately 1/16 in. (2 mm) from the bottom of the flexible conduit insert. See Figure 62.

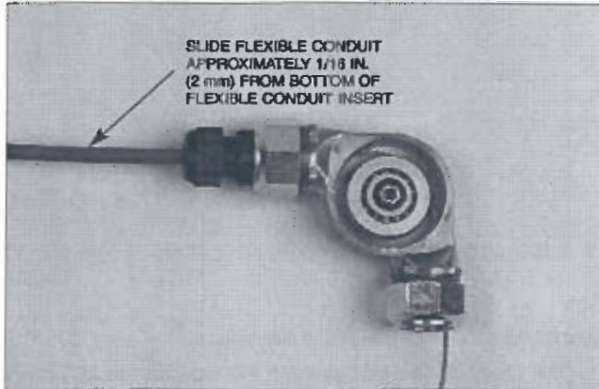

FIGURE 62
006001

8. Tighten the strain relief nut onto the strain relief. See Figure 63.

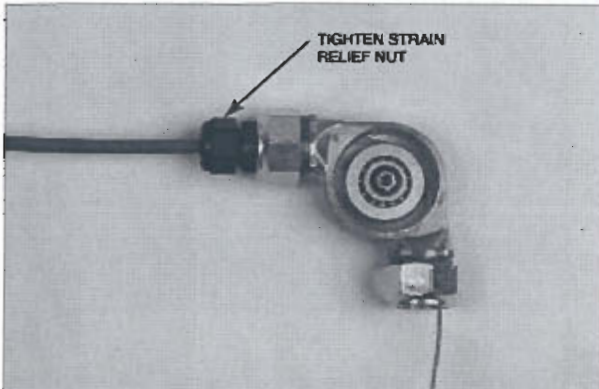

FIGURE 63
006002

9. Complete the same procedures on the other end of the conduit fitting as described in Steps 1 through Step 8 above.

Assembling the Block

Note: For installations that do not require the tee block, refer to page 5-17.12 for instructions.

1. The flexible conduit and wire rope should be connected to the electrical box as described in "Connecting the Flexible Conduit to the ANSUL AUTOMAN Release, Electrical Box, or Mechanical Gas Valve." See Figure 64.

Note: For 1 1/2 in. (3.8 cm) deep electrical box, the bearing should be installed in the block's shallow box location.

For 2 1/8 in. (5.4 cm) deep electrical box, the bearing should be installed in the block's deep box location.

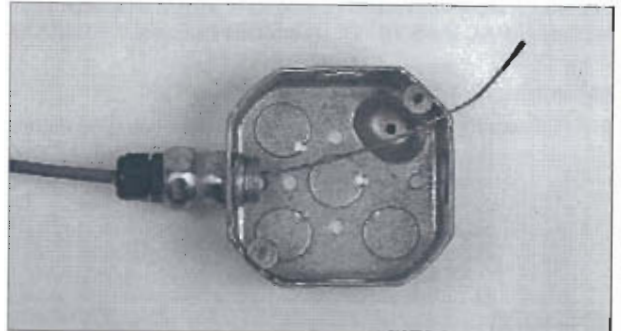

FIGURE 64
006003

2. Thread the wire rope through the small end of the block into the bearing area to be used. See Figure 65.

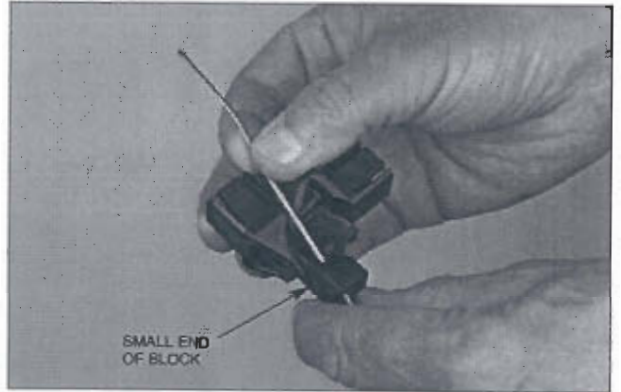

FIGURE 65
006004

3. Pull slack, make a loop and insert the rope through the larger opening in the bearing area. See Figure 66.

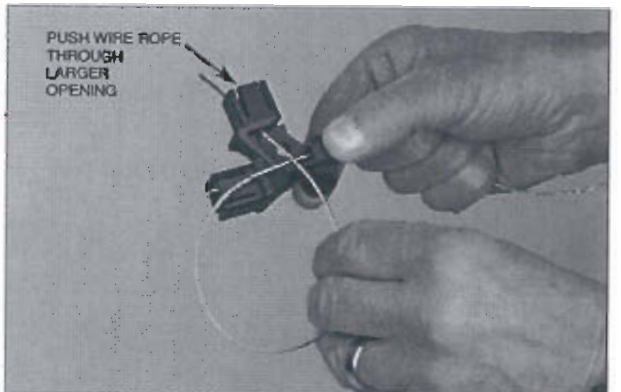

FIGURE 66
006005

**INSTALLATION OF REMOTE MANUAL PULL STATION OR
MECHANICAL GAS VALVE UTILIZING FLEXIBLE CONDUIT
(Continued)**

Assembling the Block (Continued)

4. Pull wire rope out of the large end of the block. See Figure 67.



FIGURE 67
008006

5. Place the bearing against the wire rope. Make certain wire rope is in the bearing groove. See Figure 68.

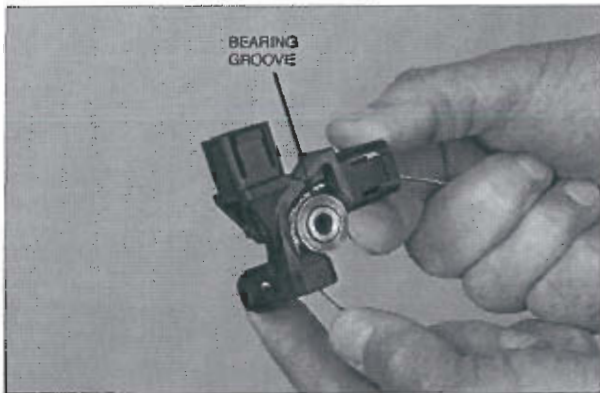

FIGURE 68
008007

6. Align the bearing against the wire rope so that the bearing center and the hole in the block line up. See Figure 69.

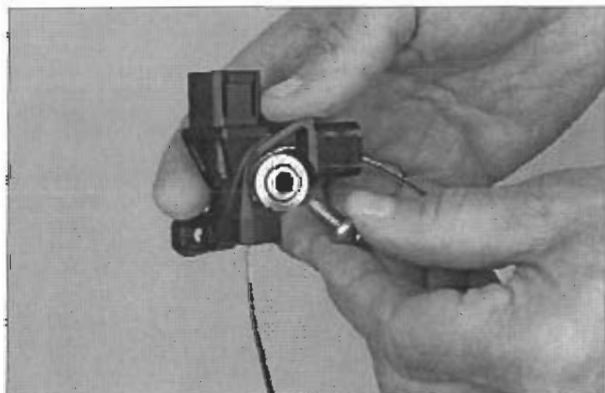

FIGURE 69
008008

7. Insert the supplied bolt into the bearing and tighten securely. Take care not to strip the thread. See Figure 70.

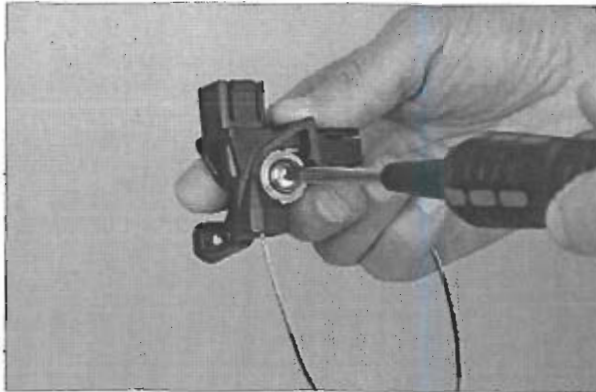

FIGURE 70
008009

Connecting the Block and the Faceplate

1. The block can be inserted into the faceplate at 90° intervals. See Figure 71.

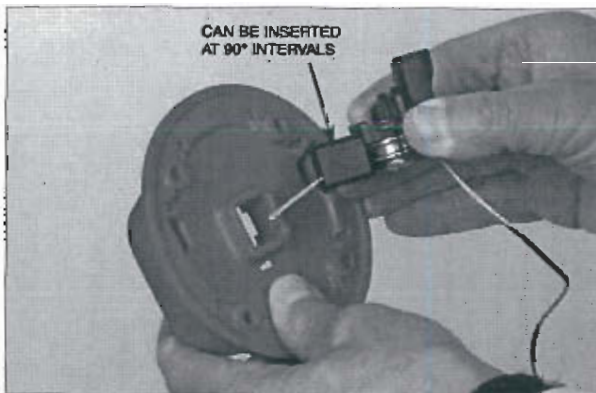

FIGURE 71
008010

2. Thread the wire rope through the faceplate. Insert the block by depressing the tabs and pushing the block into the faceplate until it snaps in place. See Figure 72.

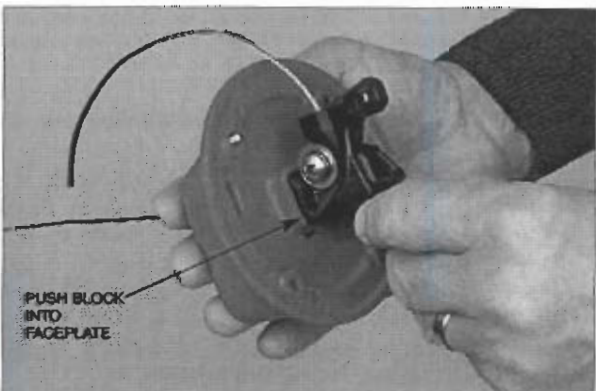

FIGURE 72
008011

INSTALLATION OF REMOTE MANUAL PULL STATION OR MECHANICAL GAS VALVE UTILIZING FLEXIBLE CONDUIT (Continued)

Connecting the Block and the Faceplate (Continued)

- Place the faceplate over the top of the electrical box and insert the two screws to secure the faceplate. See Figure 73.



FIGURE 73
008012

- Thread the wire rope through the pull knob. See Figure 74.



FIGURE 74
008013

- Thread the wire rope through stop sleeve and leave approximately 1/4-3/8 in. extended past sleeve. Crimp the stop sleeve twice using Crimping tool, National Telephone Supply Co. Nicopress Sleeve Tool (Stock No. 51-C-887). Verify the stop sleeve is secure on the wire rope. See Figure 75.

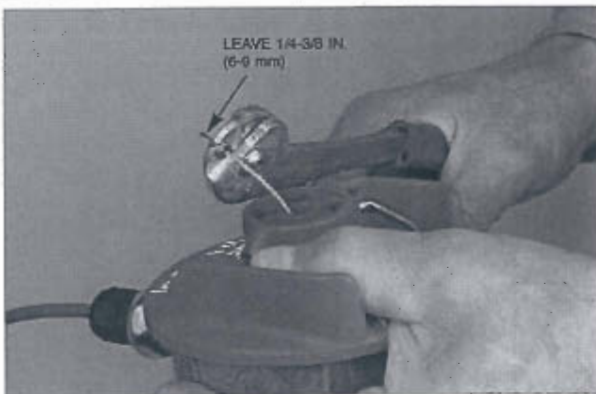

FIGURE 75
008014

- Insert the break rod into the two holes toward the top of the pull knob. See Figure 76.



FIGURE 76
008015

- Pull the excess slack back to the ANSUL AUTOMAN Release. This will pull the pull knob assembly in place. See Figure 77.



FIGURE 77
008016

- Hold the pull knob assembly against the faceplate. Rotate the pull knob assembly counterclockwise until the break rod and pull knob snap in place. See Figure 78.

Note: Take care in snapping in the ends of the break rod into the pull station side shields white rotating the entire assembly.

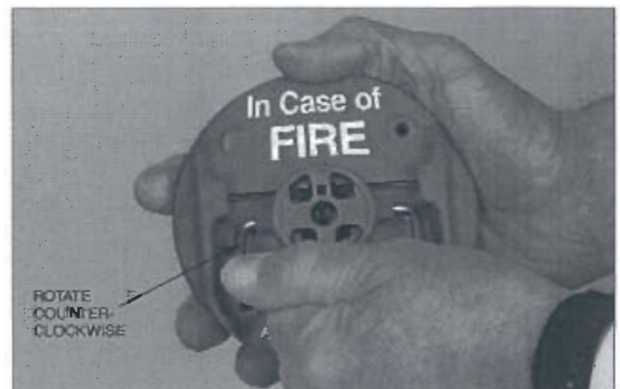

FIGURE 78
008017

INSTALLATION OF REMOTE MANUAL PULL STATION OR MECHANICAL GAS VALVE UTILIZING FLEXIBLE CONDUIT (Continued)

Connecting the Block and the Faceplate (Continued)

- 9. Snap the pull tab onto the pull knob so it is legible. See Figure 79.

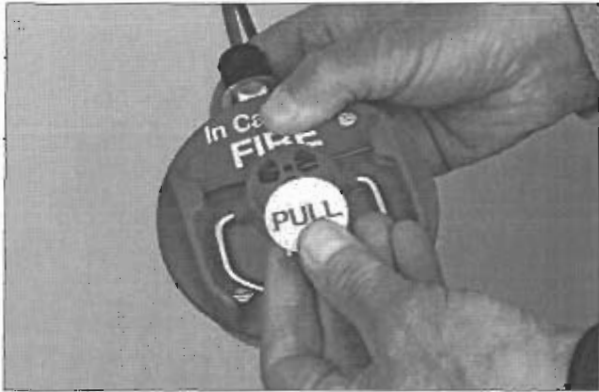

FIGURE 79
008018

- 10. Refer to R-102 or PIRANHA installation manual to complete system installation.
- 11. Test Remote Manual Pull Station and Mechanical Gas Valves in accordance with the "Testing and Placing in Service" Testing Manual Pull Station and Testing Mechanical Gas Valves section of this manual.

Installing Flexible Conduit Through a Conduit Offset

- 1. Starting at the ANSUL AUTOMAN Release, connect the conduit connector using the supplied nut. Use only ANSUL conduit fittings, Part No. 55813. See Figure 80.

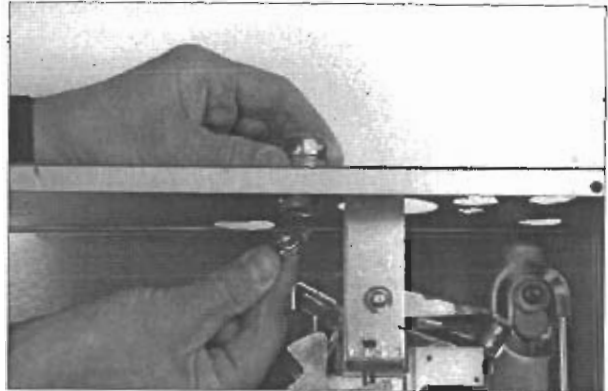

FIGURE 80
007988

- 2. Install Conduit Offset, Part No. 79825, into conduit connector and tighten nut. See Figure 81.

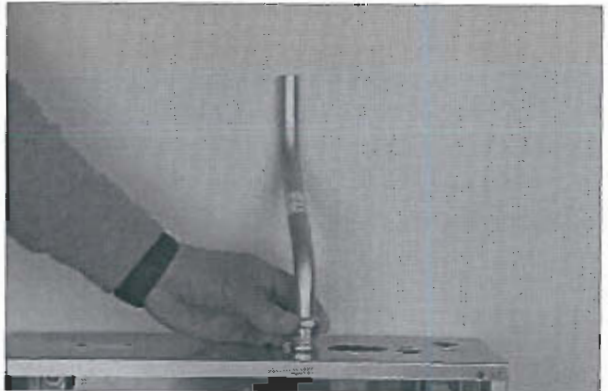

FIGURE 81
008039

- 3. Install compression union to opposite end of conduit offset. Tighten securely. See Figure 82.



FIGURE 82
008040

INSTALLATION OF REMOTE MANUAL PULL STATION OR MECHANICAL GAS VALVE UTILIZING FLEXIBLE CONDUIT (Continued)

Installing Flexible Conduit Through a Conduit Offset (Continued)

4. Install the conduit required to get above the ceiling. See Figure 83.

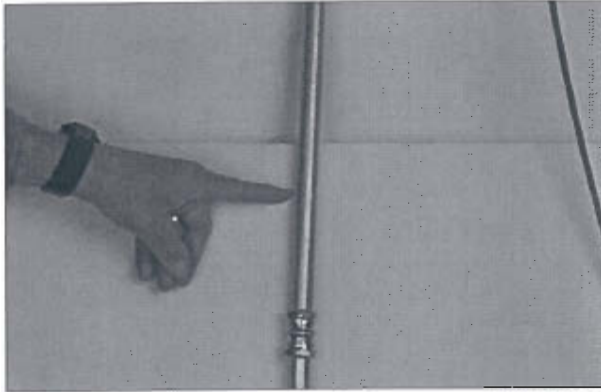

FIGURE 83
008041

5. Install compression union to top of conduit riser. See Figure 84.

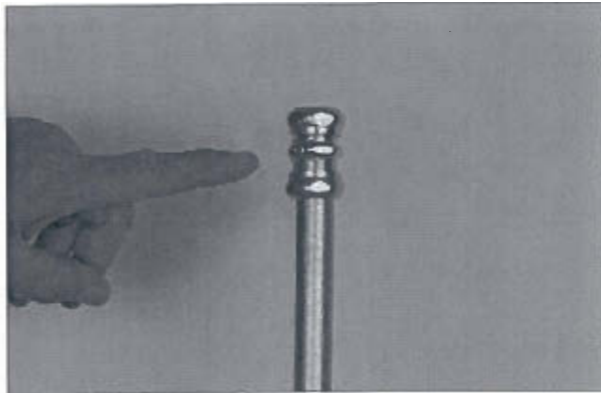

FIGURE 84
008042

6. Remove union nut and ring. Discard ring. Do not reinstall nut at this time. See Figure 85.

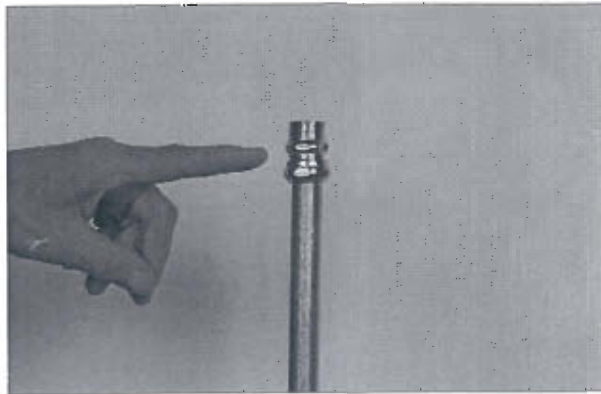

FIGURE 85
008043

7. Remove strain relief nut and install strain relief body into compression union. See Figure 86.

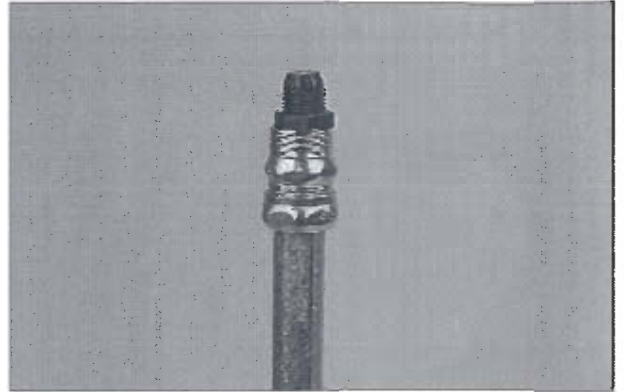

FIGURE 86
008044

8. Install union nut over strain relief body and tighten nut. See Figure 87.



FIGURE 87
008045

9. Install strain relief nut onto strain relief body. Do not tighten nut at this time. See Figure 88.

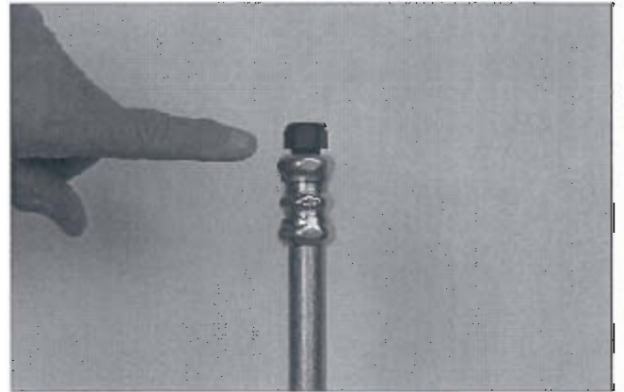

FIGURE 88
008046

SECTION V – INSTALLATION INSTRUCTIONS

UL EX3470 ULC EX3470 Page 5-17.9

REV. 0 7-1-09

INSTALLATION OF REMOTE MANUAL PULL STATION OR MECHANICAL GAS VALVE UTILIZING FLEXIBLE CONDUIT (Continued)

Installing Flexible Conduit Through a Conduit Offset (Continued)

10. Push flexible conduit completely through conduit offset. Flexible conduit should stop flush or $\pm 1/2$ in. (1.3 cm) from bottom conduit fitting in ANSUL AUTOMAN Release. See Figure 89.

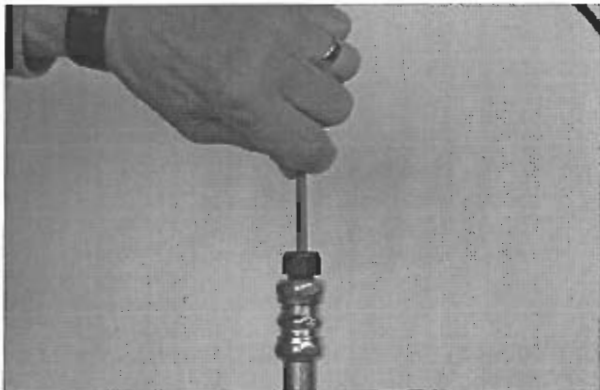

FIGURE 89
008047

11. Tighten nut on strain relief on top of conduit riser. See Figure 90.

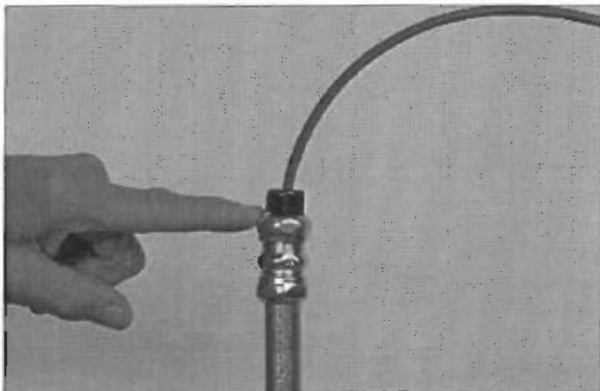

FIGURE 90
008048

12. Complete the remainder of the flexible conduit and wire rope installation to the pull station or the gas valve.

Flexible Conduit Splicing (Allowed on Pull Station Installations Only)

Note: Wire rope cannot be spliced together, only the flexible conduit.

Flexible conduit can be spliced together using EMT compression fitting union, Part No. 79827.

1. Remove rings from both ends of compression union. See Figure 91.

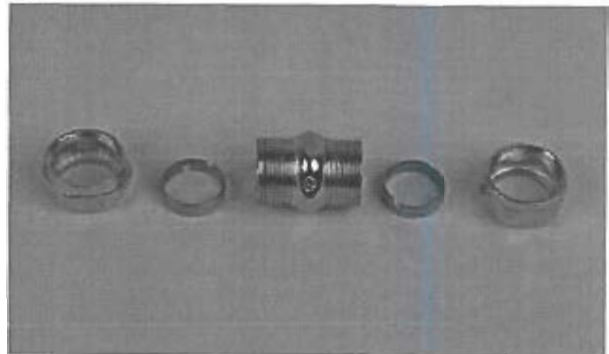

FIGURE 91
008061

2. Install strain relief nut, strain relief, compression union nut, flexible conduit insert and compression union over the flexible conduit with wire rope installed. See Figure 92.



FIGURE 92
008049

3. Tighten compression union nut onto union body, locking flexible conduit insert in place. See Figure 93.

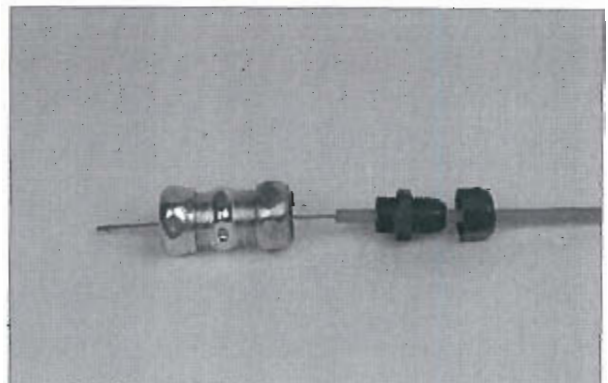

FIGURE 93
008050

INSTALLATION OF REMOTE MANUAL PULL STATION OR MECHANICAL GAS VALVE UTILIZING FLEXIBLE CONDUIT (Continued)

Flexible Conduit Splicing (Allowed on Pull Station Installations Only) (Continued)

4. Install strain relief body into compression union and tighten. See Figure 94.

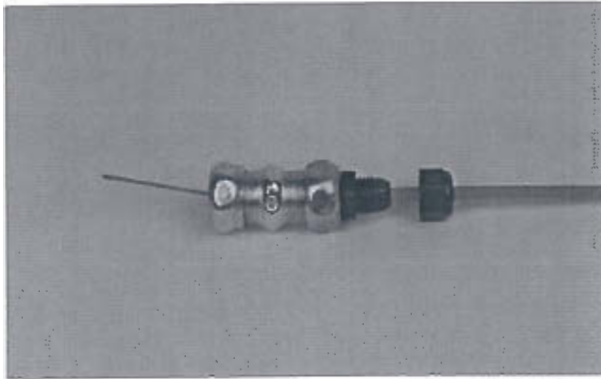

FIGURE 94
008051

5. Push flexible conduit into strain relief until it is approximately 1/16 in. (2 mm) from the bottom of the flexible conduit insert, then tighten strain relief nut onto strain relief body. See Figure 95.

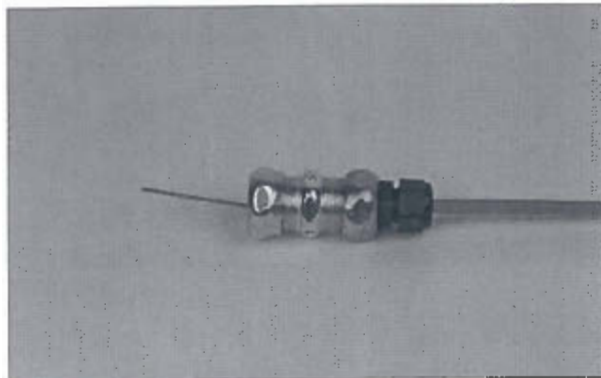

FIGURE 95
008052

6. Starting on the opposite end of the compression union, remove the nut. See Figure 96.

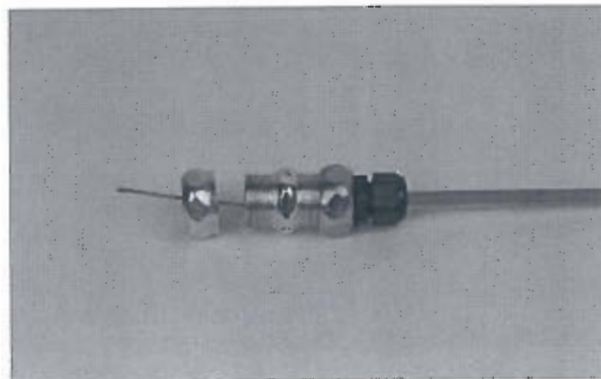

FIGURE 96
008053

7. Install strain relief nut, strain relief, and compression union nut on remaining section of flexible conduit and install flexible conduit insert on wire rope. See Figure 97.

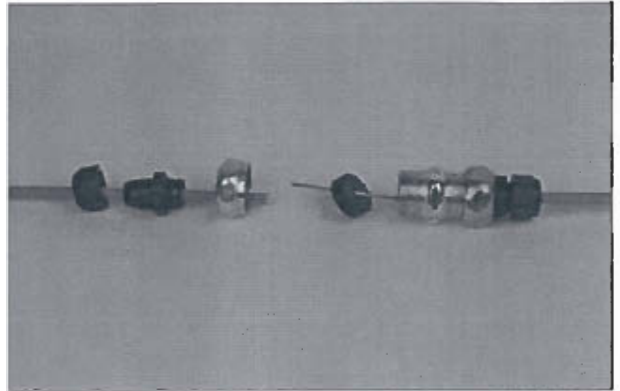

FIGURE 97
008054

8. Push wire rope completely through remaining section of flexible conduit. See Figure 98.

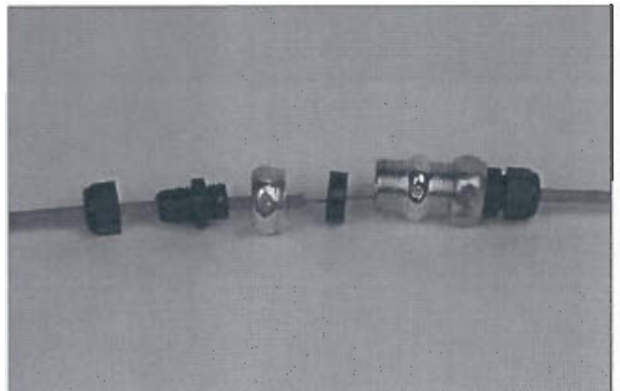

FIGURE 98
008055

9. Tighten compression union nut onto union body, securing flexible conduit insert in place. See Figure 99.

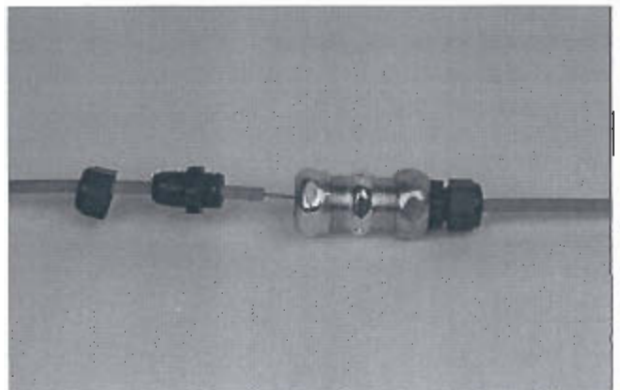

FIGURE 99
008056

INSTALLATION OF REMOTE MANUAL PULL STATION OR MECHANICAL GAS VALVE UTILIZING FLEXIBLE CONDUIT (Continued)

Flexible Conduit Splicing (Allowed on Pull Station Installations Only) (Continued)

10. Tighten strain relief into compression union. See Figure 100.

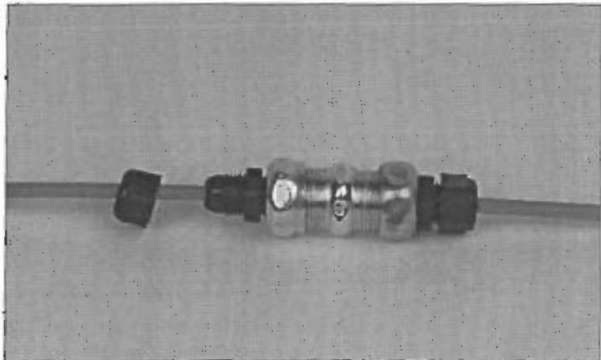

FIGURE 100
008057

11. Push flexible conduit into strain relief until it is approximately 1/16 in. (2 mm) from the bottom of the flexible conduit insert, then tighten strain relief nut onto strain relief body. See Figure 101.

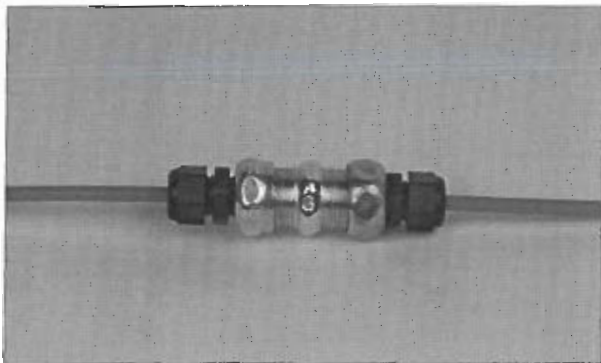

FIGURE 101
008058

12. Complete the remainder of the flexible conduit and wire rope installation to the pull station or the gas valve.

Component Removal Instructions

Removal of Block

Using thumbs on the clips on each side of the block, press firmly in the direction of the center of the block, at the same time pressing in a slightly downward direction. As the clips on the side of the block release from the pull station cover, the block will release and be free to be removed from the backside of the cover. See Figure 102.



FIGURE 102
007684

Removal of Pull Knob

Insert a small screwdriver into slot at bottom of pull knob. Push slightly on the screwdriver and turn pull knob clockwise, then pull knob can be removed without breaking the glass rod. See Figure 103.



FIGURE 103
008059

Removal of Pull Cap

Using a small screwdriver or other blunt object, push on the backside of the pull cap. This will free the cap from the pull knob. See Figure 104.

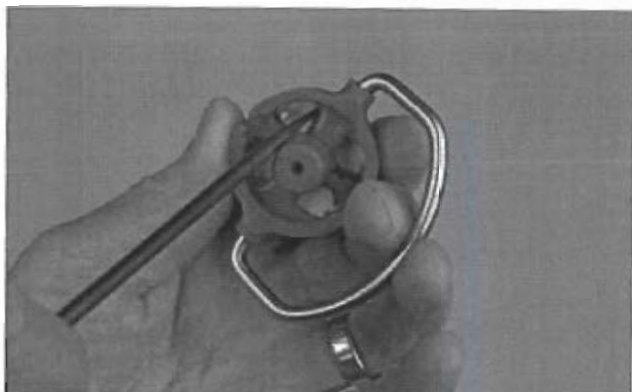

FIGURE 104
008060

INSTALLATION OF REMOTE MANUAL PULL STATION OR MECHANICAL GAS VALVE UTILIZING FLEXIBLE CONDUIT (Continued)

Pull Station Installation without Pulley Block Assembly

Note 1: When using this installation option, the distance from the back of the faceplate and the connection to the 1/2 in. EMT conduit compression fitting must not exceed 6 in. (15.2 cm).

Note 2: To provide for a straight run of wire rope from the pull station, an octagonal junction box with a center knockout in the back of the junction box will be needed. See Figure 104a. If a pre-fabricated box or enclosure is to be used, it must allow the pull station face plate to be firmly attached to the box or enclosure, with a hole or knockout suitable for a 1/2 in. EMT threaded conduit compression connector to be installed directly in line with the center of the pull station pull knob.

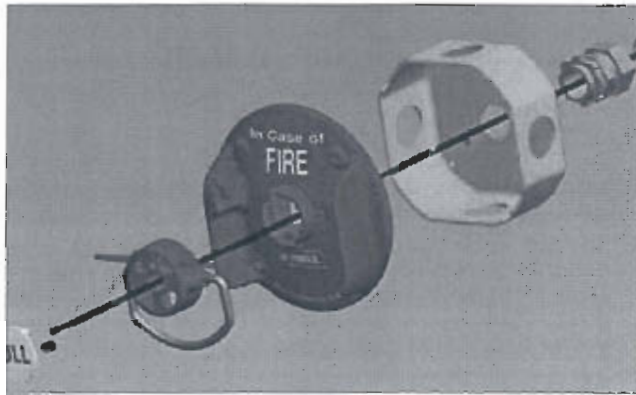

FIGURE 104a
006415

1. Attach a 1/2 in. EMT conduit compression fitting (Part No. 55813) to the back center knock out of the junction box. If something other than a junction box is to be utilized, a method of securing the flexible conduit or EMT conduit directly in line with the center of the pull station pull knob must be used. This will ensure that in the event of manual operation the wire rope, exiting the back of the pull station faceplate, will be pulled straight out without binding or resulting in undue additional pull force due to friction loss.
2. Remove the block assembly from the pull station face plate. Thread the wire rope from either flexible conduit or 1/2 in. EMT conduit attached to the back of the junction box or fabricated enclosure through the back side of the pull station faceplate and through the pull knob.
3. Thread the wire rope through the stop sleeve (Part No. 26317) and leave approximately 1/4 in. to 3/8 in. (6 mm to 10 mm) extending past the sleeve.
4. Crimp the stop sleeve twice using the crimping tool National Telephone Supply Co. Nicopress Sleeve Toll (Stock No, 51-C-887). Verify the sleeve is secure on the wire rope.

INSTALLING ELECTRICAL GAS VALVES

NOTICE

Electric gas valves are designed for indoor installation only.

The following instructions and schematics illustrate methods of procedures for installing 110 VAC Electric Gas Shut-off Valves.

1. Make certain that regulated release assembly enclosure cover is detached and lock bar is properly inserted within the regulated release mechanism.

NOTICE

Failure to follow these instructions may lead to system actuation.

2. Verify that cartridge has been removed from regulated release assembly and that the regulated release mechanism is in the cocked position.

If regulated release mechanism does not have lock bar inserted or cartridge removed, refer to the "Semi-Annual Maintenance," Page 8-1, in "Maintenance Examination" section, and complete Steps 2 and 3 before completing the following installation steps.

3.  **CAUTION**

To reduce the risk of explosion due to leaking gas, make certain that the gas line is turned off before connecting the gas valve. Gas valve installation shall be performed by qualified individuals in accordance with local jurisdiction requirements.

Install each electric gas valve to its selected location in gas line so that it ensures safe shut-off to all predetermined appliances being protected upon actuation of the system. Refer to manufacturer's instructions (if provided). See Figure 105.

- a. Use new pipe properly reamed and clean of metal chips.
- b. Install valve so that the actuator is above the horizontal pipe line with no more than a five degree (5°) lean either way.
- c. Make certain gas flow is in the same direction as arrow shown on gas valve.
- d. If strainer is utilized, attach strainer ahead of gas valve.
- e. If necessary, install drip leg in gas line in accordance with authority having jurisdiction.

CORRECT WAY:
 VISE GRIP ENDS NEXT TO PIPE BEING INSERTED. PREVENTS EXCESS STRAIN ON VALVE BODY.

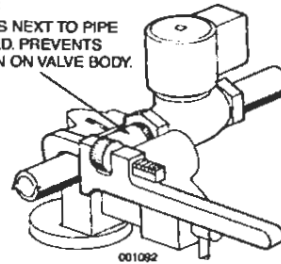

CORRECT WAY:
 WRENCH APPLIED NEXT TO PIPE BEING INSERTED PREVENTS EXCESS STRAIN ON VALVE BODY.

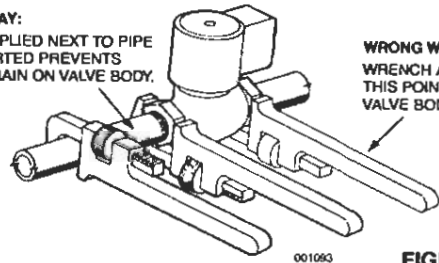

WRONG WAY:
 WRENCH APPLIED AT THIS POINT STRAINS VALVE BODY.

FIGURE 105

4. Install and secure 1/2 in. conduit from each electric gas valve to manual reset relay enclosure.
5. Tag and connect electrical wiring to each electric gas valve. Then, feed wire through conduit to manual reset relay. Tape or place a wire nut on any unused wire leads in accordance with authority having jurisdiction. Refer to Figures at the end of this section for typical wiring diagrams.

6.  **CAUTION**

Before working on any electrical wiring, make certain main power has been disconnected. Failure to disconnect main power could cause personal injury or death if contact is made with energized wires.

 **CAUTION**

All electrical wiring/connections shall be performed by qualified individuals in accordance with local jurisdiction requirements.

Connect electrical wiring to manual reset relay along with any contactor, or contractor supplied devices needed. Refer to manufacturer's instructions and proper figure listed for assistance.

7. Tape or place a wire nut on any unused wire leads in accordance with authority having jurisdiction.
8. Install and secure 1/2 in. conduit from the regulated release assembly enclosure to manual reset relay enclosure.
 If snap-action switches have not been attached, go to "Electric Switch" section and install them at this time by completing Steps 3 through 8.
9. Tag and connect electrical wiring to each electric (snap-action) switch. Then, feed wire through conduit to manual reset relay.
10. Connect wiring from each electric (snap-action) switch to manual reset relay terminals. Refer to manufacturer's instructions (if provided) and proper figure for assistance.
11. Tape or place a wire nut on any unused wire leads in accordance with authority having jurisdiction.
12. Properly return electrical power to the system.

INSTALLING ELECTRICAL SWITCHES

The procedure for field installing an electric (snap-action) switch is as follows:

CAUTION

Unused wire leads will become "hot" when the system is operated. Failure to adequately cover exposed wire end(s) will cause electric shock if touched.

CAUTION

Before working on any electrical wiring, make certain main power has been disconnected. Failure to disconnect main power could cause personal injury or death if contact is made with energized wires.

NOTICE

Except for the Alarm Initiating Switch, all electrical wiring connections are to be made outside the ANSUL AUTOMAN Release enclosure in suitable enclosures in accordance with local jurisdiction requirements.

1. Make certain that regulated release assembly enclosure cover is detached with lock bar properly inserted within the regulated release mechanism.

NOTICE

Failure to follow these instructions may lead to system actuation.

2. Verify that cartridge has been removed from regulated release assembly and that the regulated release mechanism is in the cocked position. If regulated release mechanism does not have lock bar inserted or cartridge removed, refer to the "Semi-Annual Maintenance," Page 8-1, in "Maintenance Examination" section, and complete Steps 2 and 3 before completing the following installation steps.

If regulated release mechanism has a factory installed solenoid, it will also have a factory installed switch.

3. Press each wire assembly onto the 3-terminals located on the switch(s). Be sure that the connector is pressed tight against the switch. See Figure 106.

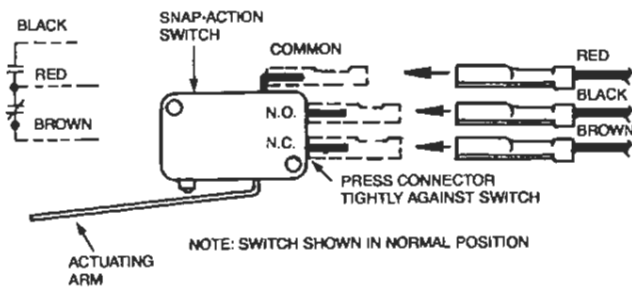

FIGURE 106
001621

4. Install switch(es) to the mounting bracket using provided fasteners and tighten securely.
5. If more than one switch is being installed, it is necessary to attach the trip lever extension stud to the trip lever. See Figure 107. Using the provided fasteners, securely install the extension stud.

6. Raise switch actuating arm squarely over the cam surface of the trip lever. This will allow the trip lever, when actuated, to force the actuating arm "UP," thus reversing the normal condition of the switch. See Figure 107.

For multiple switch installations, make certain switch actuating arms are positioned on trip lever extension stud.

Before proceeding with Step 7, test electric (snap-action) switches:

- a. Remove lock bar. With the ANSUL AUTOMAN in the cocked or ready position, press the lever of each switch up. If the switch is working properly there should be an audible click.
- b. With the ANSUL AUTOMAN in the fired position, press the lever of each switch up, there should be no audible click.

When installing multiple switches, make certain all switches transfer when the release operates. If they do not, readjust their position.

- c. If an audible click is heard in the fired position several adjustments can be made. The trip lever extension pin can be rotated so the peak of one of the hex points is pointed up against the switch levers. Tighten it in that position. If this doesn't resolve the problem, loosen the screws holding the switches, apply a small counterclockwise torque on the switches and retighten the screws. If necessary, a final adjustment can be made by removing the snap action switch and bending the lever slightly.
- d. After adjustments repeat steps a and b. Then, recock ANSUL AUTOMAN and install lock bar.

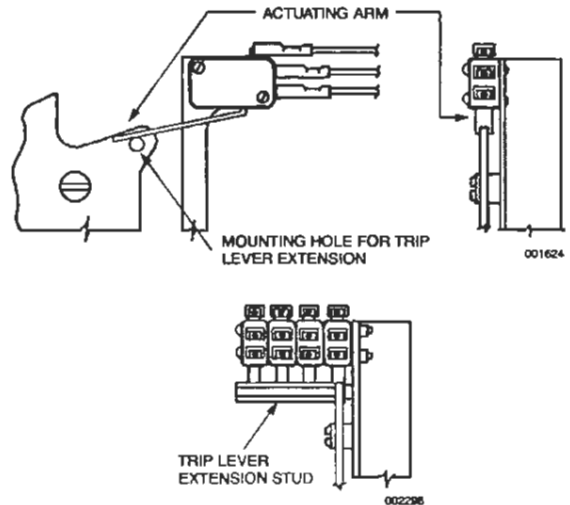

FIGURE 107

CAUTION

All electrical wiring/connections shall be performed by qualified individuals in accordance with local jurisdiction requirements.

7. The switch may now be connected to compatible components that are predetermined to shut off or turn on. Refer to component manufacturer's instructions for proper wiring connections to compatible components.

INSTALLING ELECTRICAL SWITCHES (Continued)

NOTICE

Except for the Alarm Initiating Switch, all electrical wiring connections are to be made outside the ANSUL AUTOMAN Release enclosure in suitable enclosures in accordance with local jurisdiction requirements.

- 8. Tape or place a wire nut on any unused wire leads in accordance with authority having jurisdiction.

NOTICE

Do not connect power source to any relay, contactor, or contractor supplied devices until all other electrical connections are made. Refer to proper section or manufacturer supplied instructions for recommended installation procedures for these devices.

- 9. Turn off power source and connect power line to any relay, contactor, or contractor supplied devices where used.

INSTALLING ALARM INITIATING SWITCH

The Alarm Initiating Switch Kit, Part No. 428311, consists of:

- Alarm Initiating Switch Assembly – Rated 50 mA 28VDC
- Spacer
- Mounting Screw with Nut (2)
- Extension Pin
- Extension Pin Nut
- Instruction Sheet

The Alarm Initiating Switch is mounted in the ANSUL AUTOMAN Release on the same mounting plate where the current snap-action switches are mounted. If the alarm initiating switch is used alone, the enclosed extension pin and pin nut are not needed.

When mounting the switch, the spacer must be installed first, between the ANSUL AUTOMAN mounting plate (or existing switches) and the alarm initiating switch.

See NFPA 72, "National Fire Alarm Code," Initiating Devices section, for the correct method of wiring connection to the fire alarm panel.

After the switch is properly mounted, follow the steps listed in the installation section of the Design, Installation, Recharge, and Maintenance Manual for correct positioning of the switch lever on the ANSUL AUTOMAN cam surface.

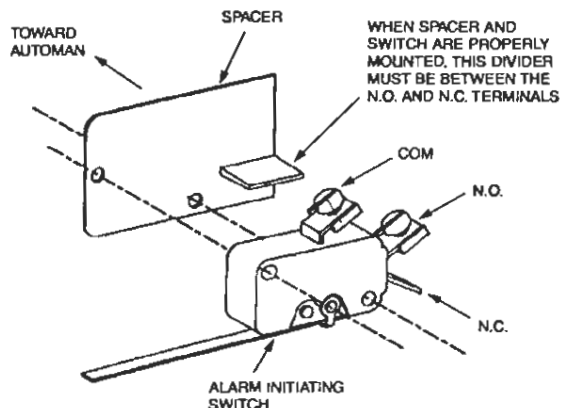

FIGURE 108
004830

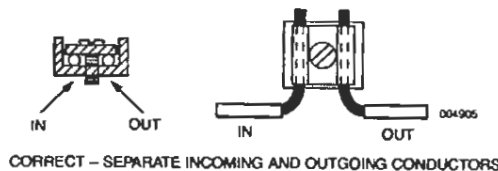
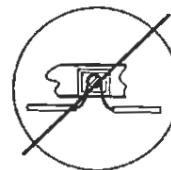
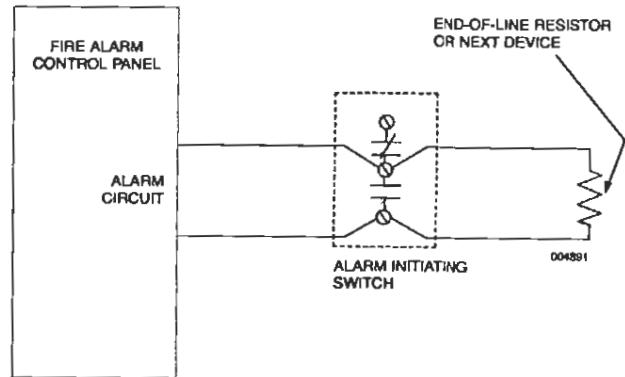
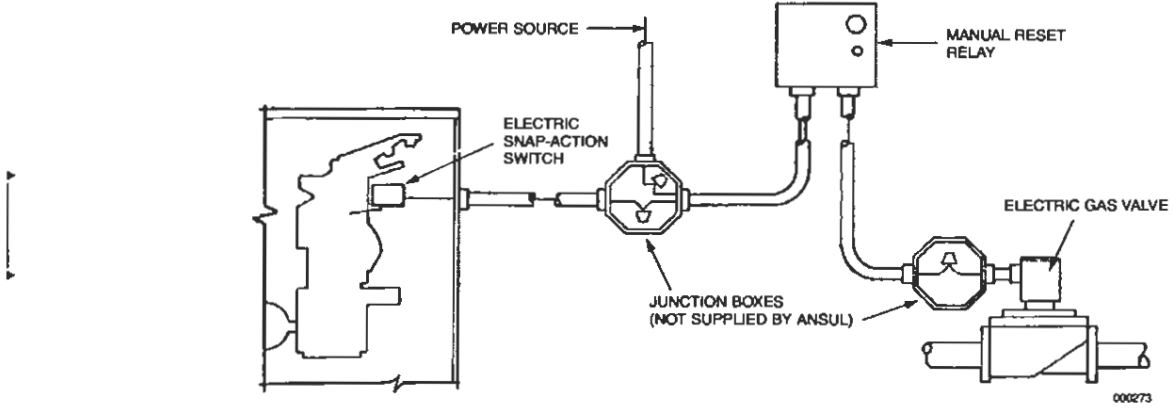

FIGURE 109

Note: With the exception of the Alarm Initiating Switch, all electrical connections must be made in an approved electrical box which also meets NEC article 314.40 (D) Grounding Provisions.

ELECTRICAL SWITCH REQUIREMENTS
Electric (110 VAC/60 Hz) Gas Shut-off Valve
INSTALLATION OVERVIEW



WIRING SCHEMATIC

WIRING SCHEMATIC – RELAY PART NO. 426151

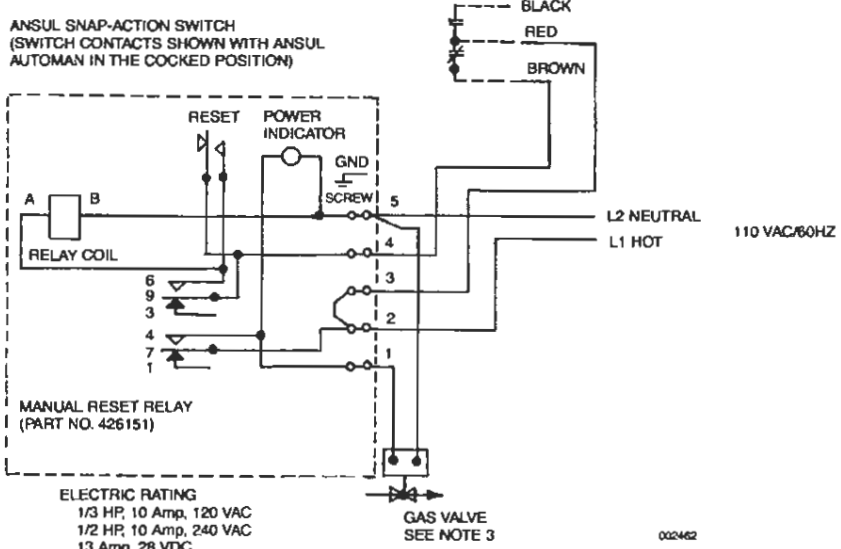

- NOTE:**
1. _____ DENOTES FIELD INSTALLATION.
 2. _____ DENOTES FACTORY INSTALLATION.
 3. CONTRACTORS: "UL LISTED ENCLOSED INDUSTRIAL CONTROL EQUIPMENT OR MAGNETIC SWITCH HAVING A RATING MATCHING THAT OF THE COOKING APPLIANCE COIL, 110V/60HZ."
 4. DO NOT USE BLACK WIRE ON SNAP-ACTION SWITCH IN NORMAL INSTALLATION. BLACK WIRE TO BE USED ONLY FOR EXTRANEIOUS ALARM, LIGHT CIRCUITS, ETC.

FIGURE 110

ELECTRICAL SWITCH REQUIREMENTS (Continued)

Electric (110 VAC/60 Hz) Application with Customer Supplied Contactor and Heating Element Load
INSTALLATION OVERVIEW

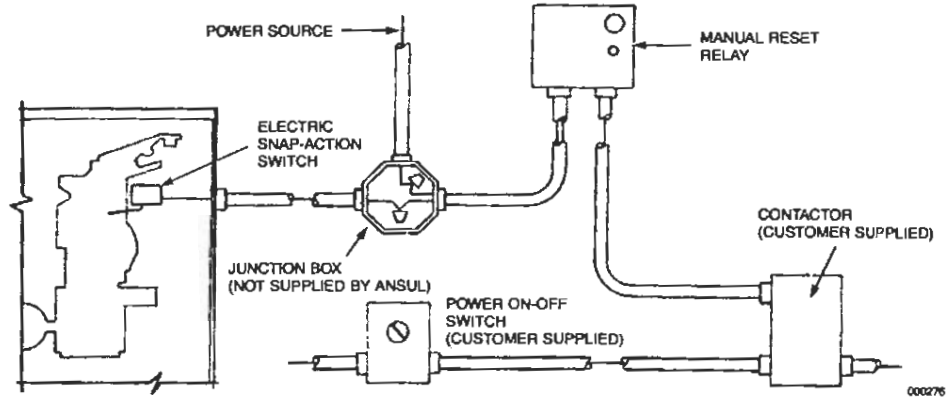

WIRING SCHEMATIC

WIRING SCHEMATIC – RELAY PART NO. 426151

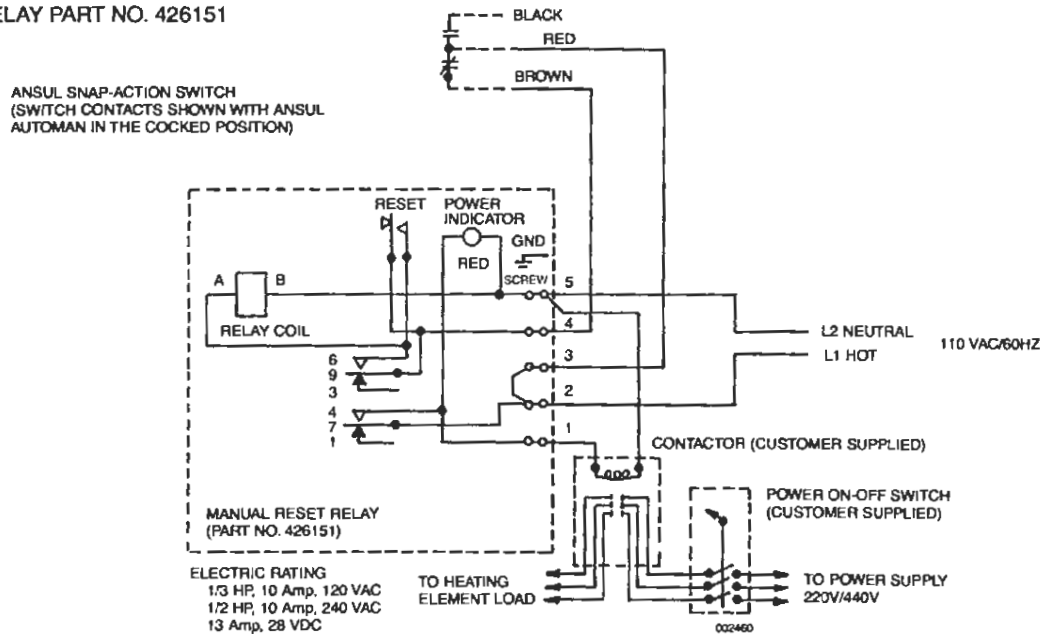

NOTE:

1. _____ DENOTES FIELD INSTALLATION.
2. - - - - - DENOTES FACTORY INSTALLATION.
3. GAS VALVES: "UL LISTED ELECTRICALLY-OPERATED SAFETY VALVE FOR NATURAL, OR LP GAS AS NEEDED OF APPROPRIATE PRESSURE AND TEMPERATURE RATING, 110V/60 HZ" OR ANSUL GAS VALVES, PART NUMBERS 13707, 13708, 13709, 13710, AND 17643.
4. DO NOT USE BLACK WIRE ON SNAP-ACTION SWITCH IN NORMAL INSTALLATION. BLACK WIRE TO BE USED ONLY FOR EXTRANEIOUS ALARM, LIGHT CIRCUITS, ETC.

FIGURE 111

ELECTRICAL SWITCH REQUIREMENTS (Continued)

**Electric (110 VAC/60 Hz) Application with Customer Supplied Contactor and Heating Element Load, and Power Supply Switch
 INSTALLATION OVERVIEW**

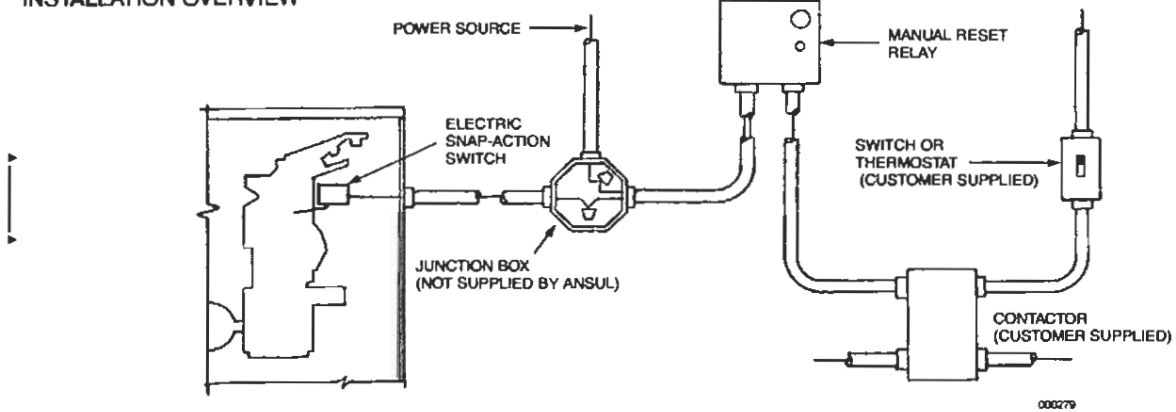

WIRING SCHEMATIC

WIRING SCHEMATIC – RELAY PART NO. 426151

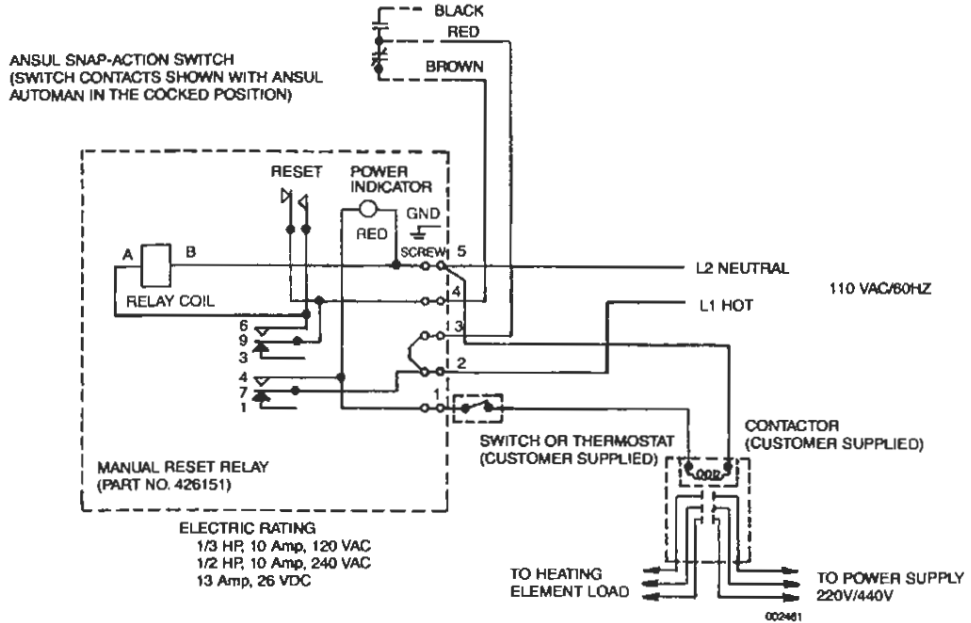

NOTE:

1. _____ DENOTES FIELD INSTALLATION.
2. - - - - - DENOTES FACTORY INSTALLATION.
3. CONTRACTORS: "UL LISTED ENCLOSED INDUSTRIAL CONTROL EQUIPMENT OR MAGNETIC SWITCH HAVING A RATING MATCHING THAT OF THE COOKING APPLIANCE COIL, 110V/60HZ."
4. DO NOT USE BLACK WIRE ON SNAP-ACTION SWITCH IN NORMAL INSTALLATION. BLACK WIRE TO BE USED ONLY FOR EXTRANEIOUS ALARM, LIGHT CIRCUITS, ETC.

FIGURE 112

SECTION V – INSTALLATION INSTRUCTIONS
UL EX3470 ULC EX3470 Page 5-20.4
REV. 0 7-1-09

NOTES:

**WIRING 24 VDC REGULATED RELEASE ASSEMBLY
 (ULC APPROVED ONLY)**

Refer to the following notes and wiring diagram for instruction on wiring the 24 VDC regulated release assembly.

Notes:

1. To be connected to a nominal 12 VDC or 24 VDC releasing circuit.
 Input power: 450 mA at 12 VDC or 750 mA at 24 VDC.
 Solenoid on time: Approximately 50 milliseconds.
2. Polarization: Observe polarity when connected to a release circuit; Terminal 4 positive, Terminal 8 negative.
3. All interconnecting wiring must be 18 AWG minimum.
4. S₁ contact rating: 15A, 1/3 HP, 125 or 250 VAC resistive; 1/2A, 125 VDC; 1/4A, 250 VDC; 5A, 120 VAC inductive.
5. SOL₁ coil resistance: 28 OHMS +/- 10% at 77 °F (25 °C).
6. Install the in-line supervisory device SD_x across terminals No. 4 and No. 5. Refer to the releasing panel installation instructions for supervisory device requirements. If an in-line supervisory device is not required, install jumper J₂ across terminals No. 4 and No. 5.

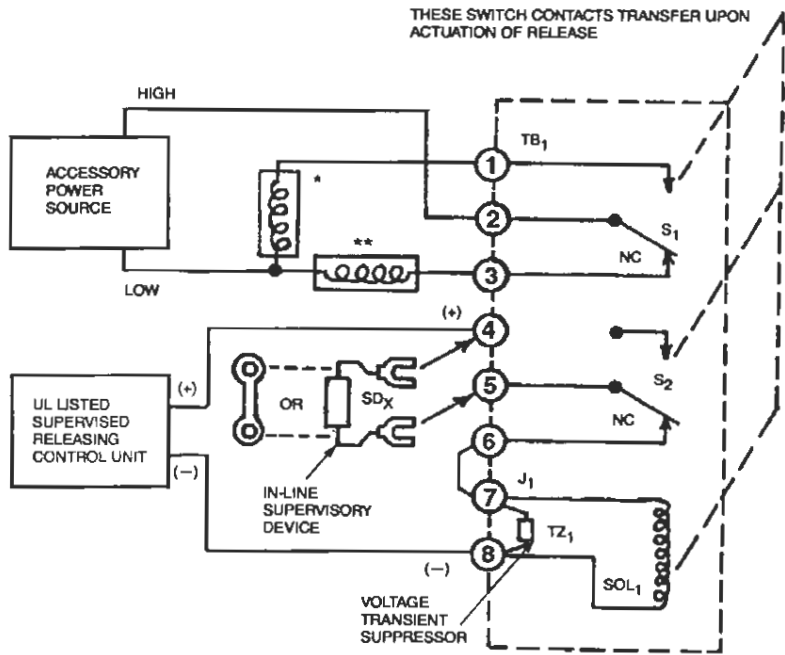

* AUXILIARY ALARMING DEVICES, SEE S₁ RATINGS
 ** FUEL SHUT-OFF VALVE, BLOWER MOTOR, DOOR CLOSER, ETC., SEE S₁ RATINGS.

FIGURE 113
 002300

SECTION V – INSTALLATION INSTRUCTIONS
UL EX3470 ULC EX3470 Page 5-22
REV. 4 7-1-09

NOTES:

After the system has been completely installed, and **BEFORE INSTALLING THE CARTRIDGE**, the system must be tested at the regulated release assembly. The testing information listed in this section deals with the limitations and parameters of this pre-engineered system. Those individuals responsible for the testing of the R-102 system must be trained and hold a current ANSUL certificate in an R-102 training program.

Note: ANSUL AUTOMAN Release must be in the cocked position before testing manual pull station. Make certain to remove lock bar before performing pull station testing.

TESTING MANUAL PULL STATION

To test each remote manual pull station, complete the following steps:

1. With the expellant gas cartridge removed, remove lock bar from regulated release assembly cable lever.
2. On pull station, remove break rod from the pull station by inserting a small screwdriver into slot at bottom of pull knob to facilitate turning the pull knob. Push slightly on the screwdriver and turn pull knob clockwise, then the pull knob can be removed without breaking the glass rod.

NOTICE

Take care in removing the break rod from the pull station side shields while rotating the break rod/pull knob assembly.

3. Pull ring handle on pull station. If the regulated release assembly is tripped easily, the remote manual pull station is properly installed. If the regulated release assembly does not trip, remove pulley tee (if provided) and each pulley elbow cover to make certain wire rope is resting on the pulley sheave. If this does not correct the problem, there is too much slack in the line and it must be retightened.
4. Recock regulated release assembly using cocking lever (Part No. 14995 or 435603) and reinstall lock bar (Part No. 14985).
5. On pull station, insert the break rod into the two holes toward the top of the pull knob. Rotate the pull knob counterclockwise.

NOTICE

Take care in snapping in the ends of the break rod into the pull station side shields while rotating the entire assembly.

NOTICE

If no other devices are being attached, proceed to Page 6-3, Step No. 1, and test the detection system.

TESTING MECHANICAL GAS VALVES

To test each mechanical gas shut-off valve complete the following steps:

- 1.

 CAUTION
To reduce the risk of explosion due to leaking gas, before the gas line is turned on, make certain to extinguish any open flames and turn off all burners and any electrical or mechanical devices that are capable of igniting gas.

Turn gas line on.

2. Manually push each air cylinder rod to full "DOWN" position. The gas valve should close. If mechanical gas valve does not trip, remove each pulley elbow cover to make certain wire rope is resting on each pulley elbow sheave. If this does not correct the problem there may be too much slack in the line and it should be retightened.
3. Test for gas leaks by painting connections with a soap solution. Bubbles indicate a gas leak. Tighten connections where leaks appear and repeat test again to make certain no other gas leaks exist.
4. If no gas leak is found, pull air cylinder rod to full "UP" position.
5. Recock mechanical gas valve.
6. Check burners for gaseous odor. **IF GASEOUS ODOR EXISTS, MANUALLY PUSH THE AIR CYLINDER ROD TO THE FULL "DOWN" POSITION IMMEDIATELY.** This will cause the mechanical gas valve to shut the gas line off.
 Open any doors and/or windows to clear the area of gaseous fumes, then correct the gas leak before proceeding any further.
7. If no gaseous odor exists, pilot light may be ignited at this time.
8. Reinstall side covers to gas valve housing. Make certain roll pin is positioned within both sides of the valve housing slot. Connect visual inspection seals (Part No. 197) on ANSUL type valves. See Figure 1.

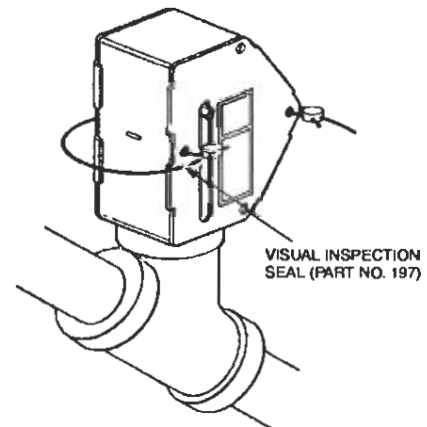

FIGURE 1
000359

9. Make certain the regulated release mechanism is cocked with lock bar in place.

NOTICE

If no other devices are being attached, proceed to Page 6-3, Step No. 1, and test the detection system.

TESTING ELECTRICAL GAS VALVES

To test each Electric Gas Shut-off Valve complete the following steps:

1.

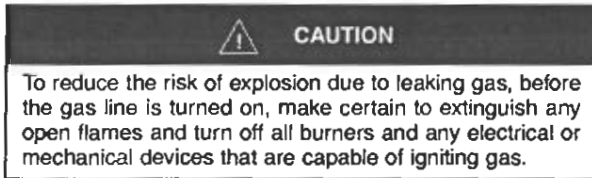

Turn gas line on.

2. Make certain electric (snap-action) switch is properly wired.
3. Make certain all other devices connected to the manual reset relay are properly wired. Refer to typical wiring diagrams in Figures 110, 111, 112, and 113 in "Installation" section.
4. Test for gas leaks by painting connections with a soap solution. Bubbles indicate a gas leak. Tighten connections where leaks appear. Repeat test again to make certain no other gas leaks exist.
5. If no gas leaks are found, turn power source on and depress the reset button on the manual reset relay (RED LIGHT ON) to energize (OPEN) electric gas valve.
6. Remove lock bar from regulated release mechanism.

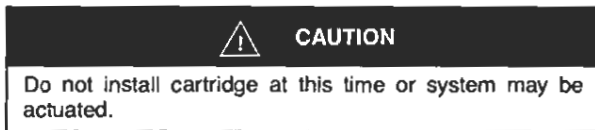

7. Manually actuate the system by operating the remote pull station. (It may be necessary to remove the glass break rod prior to operating pull station.) Manual reset relay (RED LIGHT OUT) will de-energize (CLOSE) the electric gas valve, thus shutting off the gas line. If this does not happen, turn power source off. Then re-examine all wiring connections for proper hookup. Refer to Figures 110, 111, 112, and 113 in "Installation" section for typical wiring diagrams.
8. If test is successful, recock regulated release mechanism using cocking lever (Part No. 14995 or 435603) and reinstall lock bar (Part No. 14985). Depress reset button on manual reset relay (RED LIGHT ON).
9. Check burners for gaseous odor. **IF GASEOUS ODOR EXISTS, TURN OFF POWER SOURCE IMMEDIATELY.** This will cause the electric gas valve to shut the gas line off.
Open any doors and/or windows to clear the area of gaseous fumes, then correct the gas leak before proceeding any further.
10. If no gaseous odor exists, pilot light may be ignited at this time.

NOTICE

If no other devices are being attached, proceed to Page 6-3, Step No. 1, and test the detection system.

TESTING ELECTRIC SWITCH

The procedure for testing a field installed Electric (Snap-Action) Switch is as follows:

NOTICE

If an electrical gas shut-off valve is attached to system, perform proper test procedure for the gas valve first, before completing the following steps.

1. Turn power source on and if installed, depress reset button on manual reset relay (RED LIGHT ON). All electrical devices should be operating at this time.
2. Remove lock bar.

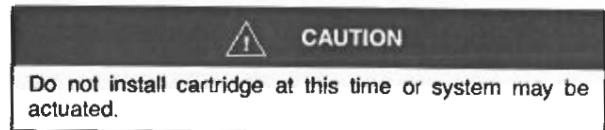

3. Manually actuate the system by operating the remote pull station. It may be necessary to remove the glass break rod prior to operating pull station. (If installed, the manual reset relay will de-energize the electric gas valve, thus shutting off the gas line.) All electrically-operated devices predetermined to shut off or turn on should do so. If this does not occur, turn power source off and make sure all wiring is properly connected and retest. Refer to Figures 110, 111, 112, and 113 in "Installation" section for typical wiring diagrams.
4. If test is successful, recock regulated release mechanism using cocking lever (Part No. 14995 or 435603) and reinstall lock bar (Part No. 14985). If a manual reset relay is installed, depress the reset button (RED LIGHT ON). It will also be necessary to re-light any pilot lights on the cooking appliances.

NOTICE

If no other devices are being attached, proceed to Page 6-3, Step No. 1, and test the detection system.

TESTING DETECTION SYSTEM

1. Test detection system by completing the following steps:
 - a. Raise the regulated release mechanism tension lever to the "UP" position.
 - b. Remove the fusible link from the terminal detector and install a test link (Part No. 15751). See Figure 2.



TEST LINK

FIGURE 2
000063

- c. Locate detector linkage and center in each bracket.
 - For "clip on" style linkage, locate linkage in bracket slightly toward termination end of detection run.
 - For "scissor" style linkage, locate linkage in bracket all the way toward termination end of detection run.
 - d. Lower regulated release mechanism tension lever to "DOWN" position and **remove lock bar**.
 - e. Using a wire cutter, cut the test link at the terminal detector to simulate automatic actuation.
 - f. If system actuates successfully, go to Step 4.
2. If the regulated release mechanism does not actuate, check the following components and remedy any disorder as follows:
 - a. Check the detector linkage for correct positioning.
 - b. Check the wire rope for knotting or jamming.
 - c. Check pulley elbows to see that wire rope is free and centered in pulley sheaves. If any evidence of pulley elbow deformation is found, replace the pulley elbow.
 - d. Make certain that lock bar is removed.
 - e. Make certain that regulated release mechanism is cocked.
 - f. Make certain that tension lever is in "DOWN" position.
 3. Re-test the system by completing the following steps:
 - a. Make certain regulated release is cocked and lock bar is inserted.
 - b. Raise the regulated release mechanism tension lever to the "UP" position.
 - c. Install a new test link (Part No. 15751) on the terminal detector.
 - d. Lower the regulated release mechanism tension lever to the "DOWN" position.
 - e. Check for 1/4 in. (6.4 mm) minimum 3/8 in. (9.5 mm) maximum clearance between the trip hammer assembly and the cable lever assembly.
 - f. Remove the lock bar.
 - g. Using a wire cutter, cut the test link at the terminal detector to simulate automatic actuation.

4. Upon successful actuation of the system, complete the following steps:
 - a. Raise tension lever to "UP" position and install a properly-rated fusible link in the terminal detector.
 - b. Cock regulated release mechanism using cocking lever (Part No. 14995 or 435603) and insert lock bar (Part No. 14985).
 - c. Lower tension lever to "DOWN" position.
 - d. For "scissor" style linkage, locate linkage in bracket all the way toward termination end of detection run.
 - e. Make certain the 1/4 in. (6.4 mm) minimum to 3/8 in. (9.5 mm) maximum clearance was maintained between the base of the trip hammer assembly and the cable lever assembly.

NOTICE

Reset any electrical equipment that may have been affected by the system actuation.

- f. Remove shipping cap and weigh each cartridge. Replace if weight is 1/2 ounce (14.2 g), or more, below weight stamped on cartridge.
- g. Install cartridge into the regulated release mechanism receiver and each regulated actuator receiver. Hand tighten firmly.
- h. Remove the lock bar.
- i. Install cover on regulated release assembly and each regulated actuator assembly and secure with appropriate fasteners or visual inspection seal. Insert seal (Part No. 197) in each upper and lower cover hole, if applicable. If system is install in an OEM enclosure, attach enclosure cover and secure with appropriate hardware or procedure.

	CAUTION
Before installing cover, make certain detection tension lever is secured in the "DOWN" position to enable automatic detection and operation of the ANSUL AUTOMAN Regulated Release.	

- j. Record installation date on tag attached to unit and/or in a permanent file.

▶ **NOTES:**



SECTION VII – RECHARGE AND RESETTING PROCEDURES

UL EX3470 ULC EX3470 Page 7-1
7-1-98 REV. 1

▶ The recharge information listed in this section deals with the limitations and parameters of this pre-engineered system. Those individuals responsible for the recharge of the R-102 system must be trained and hold a current ANSUL certificate in an R-102 training program.

For continued fire protection, the R-102 restaurant fire suppression system must be recharged immediately after use. Recharge procedures for single, double, and multiple-tank systems are as follows.

CLEANUP PROCEDURES

Although there is no unusual cleanup procedure of ANSULEX or ANSULEX Low pH agents, due to the alkaline nature of these agents, they should be cleaned from kitchen surfaces within 24 hours after system discharge. The reaction from the wet chemical agent on cooking grease or oil produces a foamy bi-product that can be wiped up with a cloth or sponge. The following procedures should be followed:

CAUTION

Before attempting any cleanup, make certain that all fuel sources to the equipment to be cleaned have been shut off. Make certain that the exhaust hood and all appliance electrical controls have been de-energized to avoid any chance of electrical shock resulting from the cleaning process or from electrically conductive alkaline liquid agent and/or its residue.

Make certain all surfaces to be cleaned have cooled down to room temperature.

Do not use water to clean any appliances that contain hot grease or cooking oils. Doing so may result in violent steaming and/or spattering.

1. The agent is non-toxic; however, food product and cooking grease/oil that has come in contact with the agent will no longer be suitable for human consumption and should be discarded.
2. Sponge up as much of the agent as possible using sponges or clean rags. Dispose of these sponges or rags in a local sanitary land fill site in accordance to local authorities. **Note:** Wear rubber gloves during cleanup as sensitive skin may become irritated. If the ANSULEX agent or its residue comes in contact with skin or eyes, flush thoroughly with clean water.
3. Using hot, soapy water and either a clean cloth or sponge, wipe away all foamy residue and thoroughly scrub all surfaces that have come in contact with the agent. **Note:** Wear rubber gloves during cleanup as sensitive skin may become irritated. If the ANSULEX agent or its residue comes in contact with skin or eyes, flush thoroughly with clean water.
4. After thoroughly cleaning all affected surfaces, adequately rinse and allow to completely dry before re-energizing the equipment.

RECHARGE

NOTICE

Determine the cause of system discharge and correct immediately before performing system recharge.

1. Remove the enclosure cover from the ANSUL AUTOMAN regulated release assembly and each regulated actuator assembly.

2. From tank in regulated release enclosure: Disconnect the expellant gas hose from each tank adaptor assembly.

From tank in mounting bracket or mounting enclosure: Disconnect expellant gas piping union at each tank adaptor inlet line(s).

3. Disconnect distribution piping union at each tank adaptor outlet line(s).

4. From tank in enclosure: Remove tank.

From tank in bracket assembly: Loosen wingnut, disengage bracket band, and remove each tank.

5. Remove each tank adaptor/tube assembly and complete the following:

- a. Remove O-ring and inspect for damage.
- b. Clean and coat O-ring with a good grade of extreme temperature grease and reinstall into adaptor groove. See Figure 1.
- c. Remove 1/4 in. vent plug.
- d. Clean and inspect for free movement and corrosion. Replace if necessary.
- e. Reinstall vent plug into adaptor body.

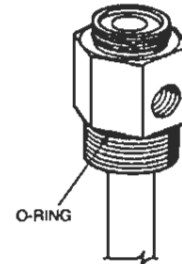

FIGURE 1
000304

- 6.

CAUTION

Do not flush pipe with only water or other non-approved material, as this could cause internal corrosion, leading to possible improper discharge.

Piping system must be flushed to remove any wet chemical residue. To prepare the system for flushing:

- a. Pour the complete contents of one 32-oz. bottle of ANSUL Flushing Concentrate (Part No. 79656) into an empty R-102 agent tank. One complete bottle is used for either size tank, the 1.5 gallon or the 3.0 gallon.
- b. Fill the tank approximately half full with warm, clean water. Agitate the tank for a few seconds and then add more warm water to bring the fill level to within approximately 1 in. (2.5 cm) from the bottom of the fill opening.

RECHARGE (Continued)

c. Install adaptor/tube assembly and tighten.

7. To perform the flushing procedure, either secure heavy-duty plastic bags to each nozzle (See Figure 2) or remove each nozzle tip and strainer and attach plastic tubing. See Figure 3.
 If using plastic bags, secure bags and proceed to Step 9.
 If using plastic tubing, proceed to Step 8.

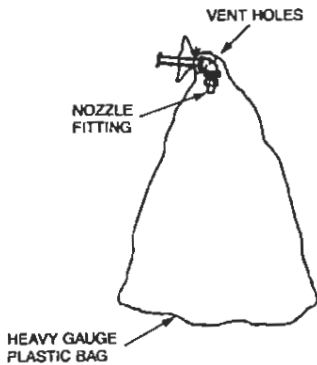

FIGURE 2
001739

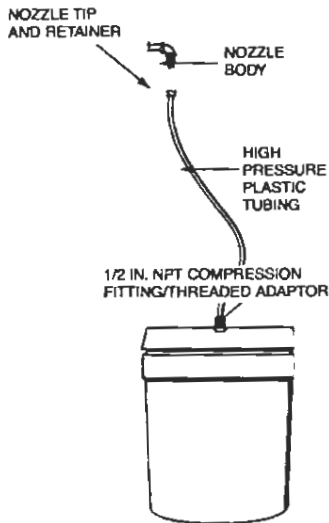

FIGURE 3
001740

8. If using the plastic tubing option, utilize 1/2 in. (1.3 cm) OD plastic tubing with wall thickness not to exceed 0.062 in. (1.6 mm), and make certain it can withstand the pressures of at least 90 psi (6.2 bar) expelled during the flushing and blow-down procedures.

Also required is a container with some means of securing tubing to it such as a five-gallon plastic pail and cover that snaps onto the pail.

To prepare the plastic tubing:

- a. Cut as many tubing lengths as required, making them long enough to reach the container from each nozzle outlet.

- b. Using a 1N nozzle tip and retainer, (Part No. 56930), slide a length of 1/2 in. (1.3 cm) plastic tubing over the rib on the nozzle tip and secure with a 1/2 in. (1.3 cm) adjustable hose clamp. See Figure 4. This nozzle tip will be connected to the nozzle body left installed in the distribution piping.
 c. In the pail cover, drill the number of holes required, large enough to insert 1/2 in. NPT fittings, with one additional hole that can be used for venting.
 d. Secure 1/2 in. compression fitting/threaded adaptors to the pail cover, using 1/2 in. conduit nuts. See Figure 4.

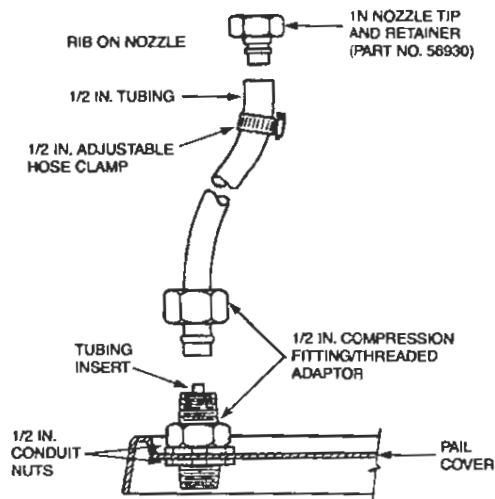



FIGURE 4
000367

- e. Attach the tubing ends to the compression fittings. Tubing inserts will be required. See Figure 4.
 f. Install nozzle/tubing ends to nozzle bodies in discharge piping.
 g. Make certain each length of tubing is fastened to the pail cover with the cover snapped securely to the pail.
 9. Complete the following steps in the flushing procedure:
 a. Connect discharge piping and expellant gas line to agent tank adaptor.
 b. Cock ANSUL AUTOMAN Release Mechanism and insert lock bar. Refer to Components Section of this manual for detailed part numbers.
 c. Install LT-30-R Cartridge; hand tighten.
 d. Remove lock bar.
 e. If regulated actuators are included in the system, also install LT-30-R cartridges in them.
 f. Actuate system via pull station.
 g. Wash out all system nozzles and strainers in warm soapy water, rinse and return all nozzles and strainers to their appropriate locations in the discharge piping.
 h. Verify that all nozzle types are correct. Utilizing the Nozzle Aiming Device, Part No. 431992, ensure that all nozzles are correctly aimed at the appropriate location on the appliance.
 i. Remove empty tank.

RECHARGE (Continued)

10. Fill each tank with 1.5 (5.8 L) or 3.0 (11.6 L) gallons of only ANSULEX Low pH Liquid Fire Suppressant. **Note:** Use a funnel with a screen to stop any foreign material from entering the tank. See Page 5-2.1, Figure 6, for detailed filling instructions.

 **CAUTION**

During filling, the agent temperature should be 60 °F to 80 °F (16 °C to 27 °C). **DO NOT FILL WITH COLD AGENT. DO NOT OVERFILL.** Overfilling may result in agent entering gas hose and regulator potentially causing system malfunction.

11. Replace bursting disc, Part No. 416974, in adaptor assembly. Make certain silver side of disc is away from tank.
12. Replace adaptor/tube assembly and tighten into place. Return and secure each tank in regulated release assembly and mounting bracket/enclosure. Reconnect expellant gas and distribution piping and/or as required.
13. Raise tension lever to "UP" position.
14. Cock regulated release mechanism using cocking lever (Part No. 14995 or 435603) and install lock bar (Part No. 14985).
15. Remove empty cartridge from regulated release assembly and each regulated actuator assembly as required.

 **CAUTION**

Do not install replacement cartridge at this time or system may be actuated.

16. Install properly-rated fusible links in all detectors except the terminal detector.

NOTICE

If actuation was caused by a fire situation, all fusible links must be replaced.

17. Install test link (Part No. 15751) in terminal detector.
18. Lower tension lever to "DOWN" position.
19. Remove the lock bar.
20. Using wire cutter, cut the test link at the terminal detector to simulate automatic actuation.

NOTICE

If regulated release mechanism does not actuate, refer to Steps 2 and 3 of the "Testing Detection System" portion of the "Testing and Placing In Service" section, Page 6-3, of this manual.

21. After successful actuation, raise the tension lever to "UP" position.
22. Install properly-rated, ANSUL approved, fusible link in terminal detector.
23. Cock the regulated release mechanism and install lock bar (Part No. 14985).
24. Locate detector linkage and correctly position in each bracket.
25. Lower tension lever to "DOWN" position.
26. Inspect the base of the wire rope clamping device to make certain there is a minimum of 1/4 in. (6.4 mm) to a maximum of 3/8 in. (9.5 mm) clearance between the base of the trip hammer assembly and the cable lever assembly.

NOTICE

If clearance is not 1/4 in. (6.4 mm) minimum to a maximum of 3/8 in. (9.5 mm), raise tension lever to "UP" position, raise trip hammer 3/8-1/2 in. (9.5-12.7 mm), tighten set screws, and repeat Steps 25 and 26.

27. Remove lock bar.
28. Manually test the regulated release mechanism by operating the remote manual pull station.
29. Recock the regulated release mechanism and insert the lock bar.
30. Reset all devices which were affected by the system actuation. Refer to "Resetting" section, Page 7-3 and 7-4.

RESETTING

Resetting Remote Manual Pull Station

► **Metal Stamped Style (Part No. 4835 and 54011)**

Reset each remote manual pull station by completing the following steps:

1. If necessary, remove set screw that is retaining the break glass rod.
2. If necessary, carefully remove any remaining broken glass from station.
3. Press and position ring handle in proper location against cover and slide the replacement glass break rod (Part No. 4834) through stud and handle.
4. Tighten set screw into stud.
5. If no other resetting is required, refer to "Cartridge Replacement," Page 7-4, and complete steps 1 through 5.

► **Molded Composite Style (Part No. 415255)**

1. Position pull ring in vertical groove of pull station cover.
2. Insert break-away seal, Part No. 79029, through holes in cover and snap in place.

► **Molded Composite Style with Side Shields (Part No. 434618 and 435960)**

1. If necessary, carefully remove any remaining broken glass from station.
2. Insert the break rod into the two holes toward the top of the pull knob.
3. Pull the excess slack back into the ANSUL AUTOMAN Release. This will pull the pull knob assembly in place.

NOTICE

Take care in snapping in the ends of the break rod into the pull station side shields while rotating the entire assembly.

4. Hold the pull knob assembly against the faceplate. Rotate the pull knob assembly counterclockwise until the break rod and pull knob snap in place.
5. Snap the PULL tab onto the pull knob so it is legible.
6. If no other resetting is required, refer to "Cartridge Replacement," Page 7-4, and complete steps 1 through 5.

RESETTING (Continued)

Resetting Mechanical Gas Shut-Off Valve

Reset each mechanical gas shut-off valve by completing the following steps:

 CAUTION

To reduce the risk of explosion due to leaking gas, before the gas line is turned on, make certain to extinguish any open flames and turn off all burners and any electrical or mechanical devices that are capable of igniting gas.

1. Remove side cover from gas valve housing.
2. Extend air cylinder rod to full "UP" position. Air cylinder is located inside the regulated release assembly enclosure.
3. Recock gas valve by pulling valve stem up so pin in stem engages in cocking lever.
4. Check burners for gaseous odor. **IF GASEOUS ODOR EXISTS, MANUALLY PUSH THE AIR CYLINDER ROD TO THE FULL "DOWN" POSITION IMMEDIATELY.** This will cause the mechanical gas valve to shut the gas line off.
Open any doors and/or windows to clear the area of gaseous fumes, then correct the gas leak before proceeding any further.
5. If no gaseous odor exists, pilot light may be ignited at this time.
6. Reinstall side cover to gas valve housing. On ANSUL type valve, make certain roll pin is positioned within both sides of the valve housing slot and secure visual inspection seal (Part No. 197).
7. If no other resetting is required, refer to "Cartridge Replacement" and complete steps 1 through 5.

Resetting Electrical Switch (Snap-Action)

Reset the electric (snap-action) switch by completing the following steps:

1. Make certain the power source is on.
2. Electric (snap-action) switch is reset automatically when the regulated release mechanism is recocked.
3. If no other resetting is required, refer to "Cartridge Replacement" and complete steps 1 through 5.

Resetting Electrical Gas Shut-Off Valve

Reset each electric gas shut-off valve by completing the following steps:

 CAUTION

To reduce the risk of explosion due to leaking gas, before the gas line is turned on, make certain to extinguish any open flames and turn off all burners and any electrical or mechanical devices that are capable of igniting gas.

1. Make certain the power source is on.
2. Depress reset button on manual reset relay (red light on). Gas valve will resume its normal operating (open) position.
3. Check burners for gaseous odor. **IF GASEOUS ODOR EXISTS, TURN OFF POWER SOURCE IMMEDIATELY.** This will cause the electric gas valve to shut the gas line off.
Open any doors and/or windows to clear the area of gaseous fumes, then correct the gas leak before proceeding any further.
4. If no gaseous odor exists, pilot light may be ignited at this time.
5. If no other resetting is required, refer to "Cartridge Replacement" and complete steps 1 through 5.

Resetting Pressure Switch

Reset the pressure switch by completing the following:

1. Depress the reset button(s) on the pressure switch cover. The pressure switch assembly(ies) is located on the right side of the regulated release enclosure. An audible click will be heard to verify the pressure switch has resumed its normal (non-actuated) condition.
2. If no other resetting is required, refer to "Cartridge Replacement" and complete steps 1 through 5.

REPLACEMENT CARTRIDGE

To complete the recharge and resetting procedures:

1. Remove shipping cap and weigh replacement cartridge. Replace if weight is 1/2 ounce (14.2 g), or more, below weight stamped on cartridge.
2. Make certain regulated release mechanism is cocked and lock bar is installed. Then, install replacement cartridge into the regulated release assembly and each regulated actuator receiver and hand tighten.
3. Remove lock bar.
4. Snap cover on regulated release and each regulated actuator assembly, insert visual seal (Part No. 197) in upper and lower cover hole and secure.

 CAUTION

Before installing cover, make certain detection tension lever is secured in the "DOWN" position to enable automatic detection and operation of the ANSUL AUTOMAN Regulated Release.

5. Record recharge date on tag attached to unit and/or in a permanent file.

The maintenance information listed in this section deals with the limitations and parameters of this pre-engineered system. Those individuals responsible for the maintenance of the R-102 system must be trained and hold a current ANSUL certificate in an R-102 training program.

Maintenance is required semi-annually. At the 12 year interval, along with the normal maintenance exam, the tank(s) must be hydro-tested and the regulator(s) must be flow tested.

- Prior to performing the required maintenance steps, verify that the R-102 system protection is designed and installed correctly for the existing appliance and ventilation system configuration. If not, make corrections as required.

SEMI-ANNUAL MAINTENANCE EXAMINATION

Semi-annual maintenance procedures for single, double, and multiple-tank systems are as follows.

NOTICE

Under certain circumstances hood and duct cleaning operations may render the fire suppression system ineffective due to a coating of cleaning chemical left on the detection equipment or mishandling of the system by cleaning service personnel. **Therefore, It is strongly recommended that the R-102 system be completely inspected and serviced by an authorized ANSUL distributor immediately following any such cleaning operations.**

1. Remove the enclosure cover from the ANSUL AUTOMAN regulated release assembly and each regulated actuator assembly.
2. Insert the lock bar (Part No. 14985) on the cocked regulated release mechanism. See Figure 1.

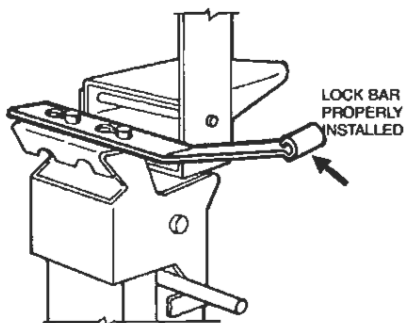

FIGURE 1
000321

3. Remove cartridge from regulated release assembly and each regulated actuator assembly, install safety shipping cap, and set aside in a safe location.
4. Check to make certain the actuation line used to connect the regulated actuator assembly(s) to the ANSUL AUTOMAN regulated release assembly is connected to the high pressure side (right side) of the cartridge receiver in the ANSUL AUTOMAN and that it is intact, with all fittings securely tightened. This includes any 1/8 in. copper tubing and fittings used to connect to the air cylinder for the ANSUL mechanical gas valve.



CAUTION

If the actuation line leaks pressure, the regulated actuator assembly(s) may not operate. A severe leak can render the entire system inoperable.

5. To check for leaks in the actuation line, a hand held or electric vacuum pump may be used:
 - a. Disconnect the actuation line from the ANSUL AUTOMAN regulated release cartridge receiver and connect the pump to the line.
 - b. The pump should pull a vacuum to 20 inches of mercury, as shown on the gauge. Leaks should not exceed 5 inches of mercury loss within a 30 second time frame.
 - c. If the gauge indicates a leak in the line, examine for loose connections or damage. Repair or replace as needed.
 - d. If leakage is not due to piping, disassemble the pneumatic actuator assembly(s) in the regulated actuator(s) and inspect the actuator and the O-ring in the actuator. Repair or replace as needed.

Note: Vacuum pumps can be obtained from automotive parts/supply stores.

Alternate Test Method:

The actuation line can also be pressurized with either CO₂ or N₂ from a cartridge or with dry air, CO₂, or N₂ from a larger cylinder.

- a. Cock the ANSUL AUTOMAN regulated release assembly and carefully insert Lock Bar, Part No. 14985. See Figure 8.
- b. Make certain expellant gas line hose and/or pipe from the regulator in the ANSUL AUTOMAN regulated release is disconnected from agent storage tanks.
- c. Connect Regulator Test Kit, Part No. 56972, to one of the expellant gas line hoses and securely cap the remaining hose or pipe. See Figure 10.
- d. Verify that no cartridges are installed in the ANSUL AUTOMAN or the regulated actuator assembly(s).
- e. To verify operation of the regulated actuator assembly(s), Pressure Adaptor, Part No. 427560, can be used to connect to a pressurized CO₂ or N₂ cylinder, instead of using a CO₂ or N₂ cartridge.

Note: The pressure adaptor assembly comes with a 1/4 in. NPT pipe plug that is required to be installed in the side of the adaptor.

- f. Install a suitable 1/4 inch air pressure quick connect fitting (supplied by others) to the bottom of the adaptor.
- g. Install and hand tighten the adaptor to the cartridge receiver and securely attach the corresponding connector from the gas cylinder hose assembly.
- h. With the valve on the regulator test kit closed, remove the lock bar and operate the remote cable operated pull station to operate the regulated release.
- i. Open the pressure cylinder valve to verify that the regulated actuator assembly(s) has operated properly and the air cylinder has unlatched the ANSUL mechanical gas valve, if used.

SEMI-ANNUAL MAINTENANCE EXAMINATION (Continued)

j. Once regulated actuator and gas valve operation is verified, close the valve on the pressurized cylinder, if used, and open the valve on the regulator test kit to relieve any residual pressure.

Note: Although only required at 12 year intervals, the regulator in the ANSUL AUTOMAN regulated release can also be verified. See Maintenance steps on page 8-6.

k. Re-cock the ANSUL AUTOMAN regulated release and remove the spent cartridge or pressure adaptor from the cartridge receiver.

l. If there were leaks in the actuation line or in the 1/8 inch copper gas tubing for the air cylinder(s), re-tighten the fittings or replace damaged components.

m. If the cartridge puncture pin in the regulated actuator(s) did not fully extend, dismantle the actuator and inspect components of the actuator assembly.

- Once the pneumatic actuator is disassembled, remove the actuator piston assembly and check the interior walls of the actuator body for signs of damage or corrosion.
- Check the o-ring for elasticity or cuts. Replace, if necessary. Clean and coat o-ring with a good grade of extreme temperature silicone grease and reinstall.
- Re-assemble the actuator assembly(s), and reconnect all actuation and all expellant piping or hose.

6. Remove gasket from cartridge receiver in regulated release mechanism and each regulated actuator. Check gasket for elasticity or cuts and replace if necessary. Clean and coat gasket lightly with a good grade of extreme temperature grease. Reinstall gasket into cartridge receiver(s).

7. From tank in regulated release assembly: Disconnect the expellant gas hose from each tank adaptor assembly.

From tank in bracket/enclosure assembly: Disconnect the expellant gas piping union at each tank adaptor inlet line.

8. Disconnect distribution piping union at each tank adaptor outlet line.

9. From tank in enclosure: Remove tank. Keep in upright position to avoid spilling the agent.

From tank in bracket assembly: Loosen wingnut, disengage bracket band, and remove each tank. Keep tank in upright position to avoid spilling the agent.

10. Remove tank adaptor/tube assembly from each tank. See Figure 2.

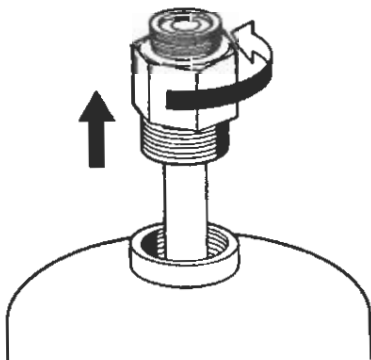

FIGURE 2
000291

- ▶ 11. Make certain that each tank is filled with 1.5 (5.8 L) or 3.0 (11.6 L) gallons of only ANSULEX Low pH Liquid Fire Suppressant. Fill level to be ONLY to the level indicated in the "Installation" section. See Page 5-2.1, Figure 6, for detailed filling tolerances.
- ▶ 12. Examine threads on each tank adaptor and tank collar for nicks, burrs, or cross-threading. Clean and coat O-ring with a good grade of extreme temperature grease. See Figure 3. Remove 1/4 in. vent plug and clean and inspect for free movement and corrosion (replace if necessary). Reinstall vent plug. Make certain bursting disc is in place and silver side is away from tank. Clean seating surface and return adaptor/tube assembly to each tank. Tighten securely.

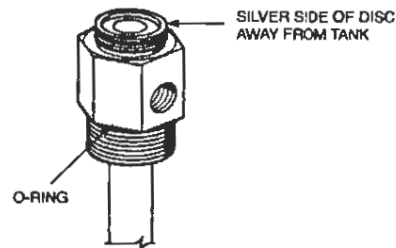

FIGURE 3
000304

- ▶ 13. Place fully charged tanks in enclosures and/or brackets and secure.
- ▶ 14. Carefully assemble and wrench tighten all expellant gas and agent distribution piping.
- ▶ 15. Remove blow-off caps from nozzles. Inspect each blow-off cap and replace if deteriorated. On older style metal blow-off caps, make certain spring clip rotates freely on cap. On newer metal blow-off caps, make certain integral O-ring is intact and undamaged. Replace cap(s) if necessary.

NOTICE

Rubber blow-off caps that have been installed in the system for one year or more must be replaced.

- ▶ 16. Verify that all nozzle types are correct. Check all nozzles to ensure that they are free of cooking grease build-up and have a thin coating of clean silicone grease across the orifice.

Note: Do not allow silicone grease to enter nozzle orifice.

Note: If there is any evidence of cooking grease or other residue in the nozzles or distribution piping or agent or agent residue in the distribution piping, the entire piping network must be inspected and thoroughly cleaned. Portions of piping that cannot be thoroughly cleaned must be replaced.

- ▶ Utilizing the Nozzle Aiming Device, Part No. 431992, ensure that all nozzles are correctly aimed at the appropriate location on the appliance. Reinstall blow-off caps.

- ▶ 17. Remove the lock bar and manually test the regulated release assembly by operating the remote manual pull station. Check pull station cover for damage or wear. Replace cover if cable has worn a groove in the cover as deep as the diameter of the cable. If flexible conduit is used in installation, check conduit for damage, cuts and sharp bends.

SEMI-ANNUAL MAINTENANCE EXAMINATION (Continued)

- ▶ 18. Cock the regulated release mechanism using cocking lever (Part No. 14995 or 435603). See Figure 4.

Before proceeding with Step 18, test electric (snap-action) switches:

- a. With the ANSUL AUTOMAN in the cocked or ready position, press the lever of each switch up. If the switch is working properly, there should be an audible click.
- b. With the ANSUL AUTOMAN in the fired position, press the lever of each switch up, there should be no audible click.
- c. If an audible click is heard in the fired position several adjustments can be made. The trip lever extension pin can be rotated so the peak of one of the hex points is pointed up against the switch levers. Tighten it in that position. If this doesn't resolve the problem, loosen the screws holding the switches, apply a small counterclockwise torque on the switches and retighten the screws. If necessary, a final adjustment can be made by removing the snap action switch and bending the lever slightly.
- d. After adjustments, repeat Steps a. and b. Then, recock ANSUL AUTOMAN and insert lock bar.

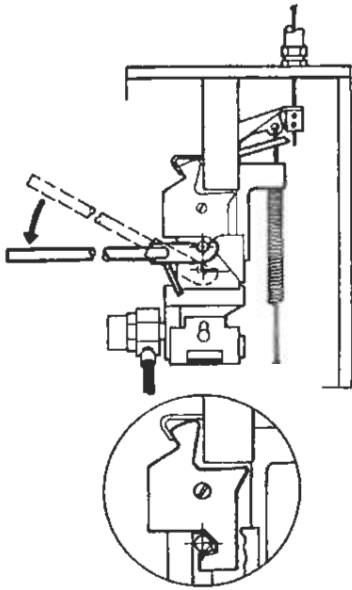

FIGURE 4
000320

- ▶ 19. Raise tension lever to "UP" position. See Figure 5.

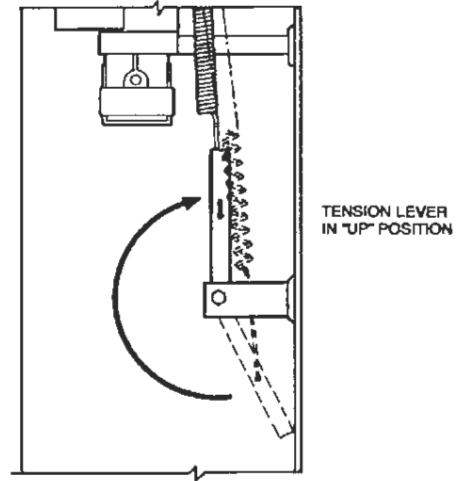

FIGURE 5
000322

- ▶ 20. Install test link (Part No. 15751) in terminal detector.
- ▶ 21. Lower tension lever to "DOWN" position. See Figure 6.

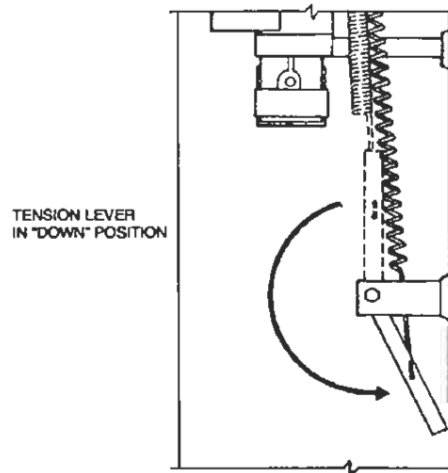

FIGURE 6
001096

- ▶ 22. Using wire cutter, cut test link at terminal detector to simulate automatic actuation.

NOTICE

If regulated release mechanism does not actuate, refer to Steps 2 and 3 of "Testing Detection System" in "Testing and Placing in Service," Section 6, Page 6-3.

- ▶ 23. After successful actuation, raise the tension lever to "UP" position.
- ▶ 24. Remove and destroy all existing fusible links from the terminal and series detector brackets and replace with properly-rated ANSUL approved, fusible links in accordance with NFPA 17A.

SECTION VIII – MAINTENANCE EXAMINATION

SEMI-ANNUAL MAINTENANCE EXAMINATION (Continued)

- ▶ 25. Inspect wire rope at all detector locations, pulley elbows, pulley tee and at ANSUL AUTOMAN release. If wire rope shows signs of wear or fraying, replace entire length.
- ▶ 26. Lower the tension lever to "DOWN" position.
- ▶ 27. Recock the regulated release mechanism and insert the lock bar.
- ▶ 28. Inspect the base of the wire rope locking clamp to make certain that there is a minimum of 1/4 in. (6.4 mm) and a maximum of 3/8 in. (9.5 mm) clearance between the base of the trip hammer locking clamp assembly and the cable lever assembly. See Figure 7.

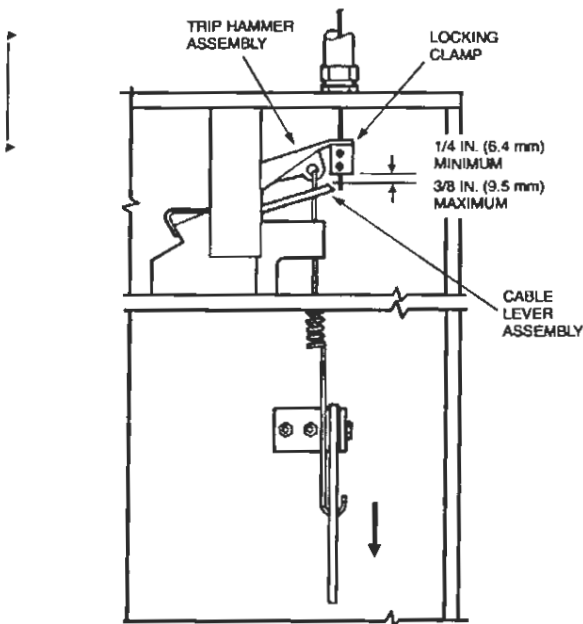

FIGURE 7
000329

NOTICE

If clearance is not between 1/4 in. (6.4 mm) or 3/8 in. (9.5 mm), raise tension lever to "UP" position, raise trip hammer 3/8-1/2 in. (9.5-12.7 mm), tighten set screws, and repeat Steps 24 and 26.

- ▶ 29. For "scissor" style linkage, locate linkage and properly position in each bracket all the way toward termination end of detection run.
- ▶ 30. If a mechanical gas valve is installed, begin the test procedure by removing both side covers.
- ▶ 31. At the regulated release, push the air cylinder rod fully down.
- ▶ 32. The gas valve should operate.
- ▶ 33. Pull the air cylinder rod to its fully extended position.
- ▶ 34. Re-cock the gas valve by pulling the valve stem up until the pin in the stem engages the cocking lever.
- ▶ 35. Reinstall side covers on the gas valve and connect the visual indication seal.

- ▶ 36. Test electric switches and electric gas valves by completing steps on Page 6-2 in Section 6, "Testing and Placing In Service."
- ▶ 37. Before reinstalling cartridge, reset all additional equipment by referring to appropriate section of "Recharge and Resetting Procedures," Section 7.
- ▶ 38. Remove shipping cap and weigh each cartridge. Replace if weight is 1/2 ounce (14.2 g), or more, below weight stamped on cartridge.
- ▶ 39. Make certain regulated release mechanism is cocked and lock bar is installed, then screw replacement cartridge into regulated release mechanism and each regulated actuator receiver(s) and hand tighten.
- ▶ 40. Remove lock bar.

CAUTION

Make certain tension lever is in the "DOWN" position after completing all tests. Failure to put the tension lever in the "DOWN" position will cause the system to not operate automatically.

- ▶ 41. Snap cover on regulated release and each regulated actuator, insert visual seal (Part No. 197) through holes in cover and box, and secure.
- ▶ 42. If system contains an Agent Distribution Hose and Restraining Cable Assembly, also perform the following steps:
 - a. Carefully pull or push out the appliance and verify that the Restraining Cable limits the travel of the appliance and prevents the application of any pull force or bending stress on the Agent Distribution Hose or hose-to-pipe connections.
 - b. Check the Restraining Cable to verify it is not frayed and is securely fastened to the appliance and the wall or restraining location.
 - c. Check the hose and hose fittings and verify that the hose remains in a vertical natural loop with no noticeable fatigue at hose end couplings, no hose twists, no hose kinking or sharp bends.
 - d. Check the outer hose covering for signs of damage, checking, tears, or wear. If any of these signs are observed, replace the hose.
 - e. Return the appliance to its normal operating position. Again, check the hose and hose fittings to verify that the hose does not have sharp bends, and is not kinked, twisted, or caught on anything behind the appliance. If any of these conditions exist, the hose and/or hose connections will require installation modifications.
 - f. With the appliance in its normal operating position, check the hose bend to make certain the bend is not less than a 3 in. (7.6 cm) bend radius (6 in. (15.2 cm) diameter). If less, replace hose.
 - g. Verify that the appliance is returned to its original desired location. Failure to do so may result in undue stress and fatigue of the hose and hose connections.
- ▶ 43. Record semi-annual maintenance date on tag attached to unit and/or in a permanent file.

ANNUAL MAINTENANCE EXAMINATION

In addition to performing all the steps necessary for Semi-Annual Maintenance, disconnect the agent discharge piping from the storage tank outlet(s) and verify that the agent distribution piping is not obstructed.

1. At least annually, use dry air or nitrogen and blow through the agent distribution piping with the nozzle blow-off caps removed, verifying that dry air or nitrogen is discharging at each nozzle location.

CAUTION

If nozzles show signs of cooking grease migration into the orifice of the nozzle, or if there is evidence of agent residue in the nozzle(s) or the inlet to the agent distribution piping, some or all of the piping may require dismantling to verify that the piping is not obstructed.

2. At least annually, all rubber nozzle blow-off caps must be replaced.

12-YEAR MAINTENANCE EXAMINATION

In addition to performing all of the steps necessary for semi-annual and annual maintenance, the following twelve-year maintenance procedures for single, double, and multiple-tank systems must be performed.

NOTICE

Under certain circumstances hood and duct cleaning operations may render your fire suppression system ineffective due to a coating of cleaning chemical left on the detection equipment or mishandling of the system by cleaning service personnel.

Therefore, it is strongly recommended that the R-102 system be completely inspected and serviced by an authorized ANSUL distributor immediately following any such cleaning operations.

At twelve-year intervals, the liquid agent tank(s) must be hydrostatically tested and refilled with a fresh charge of ANSULEX Low pH Liquid Fire Suppressant. The date of manufacture is stamped on the bottom of the agent tank or on the tank label.

1. Remove the enclosure cover from the ANSUL AUTOMAN regulated release assembly and each regulated actuator assembly.
2. Insert the lock bar (Part No. 14985) on the cocked regulated release mechanism. See Figure 8.

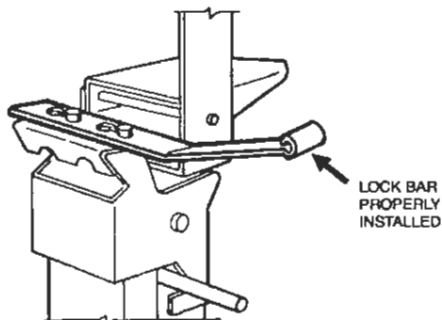

FIGURE 8
00021

3. Remove cartridge from regulated release assembly and each regulated actuator assembly, install safety shipping cap, and set aside in a safe location.

CAUTION

Do not reinstall cartridge at this time or system may be actuated.

4. Remove gasket from cartridge receiver in regulated release mechanism and each regulated actuator. Check gasket for elasticity or cuts and replace if necessary. Clean and coat gasket lightly with a good grade of extreme temperature grease. Reinstall gasket into cartridge receiver(s).
5. From tank in enclosure: Disconnect the expellant gas piping or hose from each tank adaptor assembly.
 From tank in bracket assembly: Disconnect expellant gas piping union at each tank adaptor inlet line.
6. Disconnect distribution piping union at each tank adaptor outlet line.
7. From tank in enclosure: Remove tank.
 From tank in bracket assembly: Loosen wingnut, disengage bracket band, and remove each tank. Keep tank in upright position to avoid spilling the agent.
8. Loosen tank adaptor/tube assembly and remove.

CAUTION

Safety glasses should be worn during transfer operations of ANSULEX Low pH Liquid Fire Suppressant. Avoid contact with skin or eyes. In case of contact, flush immediately with water for 15 minutes. If irritation persists, contact a physician. Do not take internally. If taken internally do not induce vomiting. Dilute with water or milk and contact a physician.

Pour the liquid agent from the tank into a clean, plastic container, and flush tank with clear water.

10. At this point, each liquid agent tank, including the 1/4 in. gas hose assembly, must be **HYDROSTATICALLY TESTED** to 330 psi (26.6 bar). Refer to "Hydrostatic Test Instructions," F-7602, for test adaptors and instructions.

NOTICE

DO NOT hydrostatically test a red painted mild steel agent storage tank. Instead, replace the tank with a new stainless steel tank shipping assembly (3-Gallon, Part No. 429862, or 1.5 Gallon, Part No. 429864).

11. Verify date stamped on cartridge. The cartridge must also be hydrotested at intervals not greater than 12 years. (European cartridges are not refillable, therefore cannot be hydrotested and refilled. They must be discarded).
12. If cartridge date indicates the need for hydrotesting, the cartridge must be bled down through normal ANSUL AUTOMAN release operation, returned to ANSUL for credit (or hydrotested by properly trained and ANSUL Authorized cartridge refilling stations), and replaced with a charged, replacement cartridge.

SECTION VIII – MAINTENANCE EXAMINATION

UL EX3470 ULC EX3470 Page 8-6
REV. 5 7-1-09

12-YEAR MAINTENANCE EXAMINATION (Continued)

NOTICE

Cartridge bleed down can be used to verify pneumatic accessories operation.

- 13. If system contains an Agent Distribution Hose and Restraining Cable Assembly, a hydrostatic test is required at 220 psi (15.2 bar) for hose assembly.
- 14. The regulator must be flow tested at 12 year intervals. Check the date code stamped on the regulator body to determine if the regulator(s) requires the 12 year testing (see data code table). If regulator does not require testing, proceed to step 12. Flow test the regulator(s) per the following:

Date Code Table

Month	Code	Year	Code UL 541L	Code UL 74FF
January	A	1981	K	
February	B	1982	L	
March	C	1983	M	
April	D	1984	N	
May	E	1985	P	
June	F	1986	R	
July	G	1987	S	
August	H	1988	T	
September	J	1989	U	
October	K	1990	V	
November	L	1991	W	
December	M	1992	Y	
		1993	Z	
		1994	A	
		1995	B	
		1996	C	
		1997	D	
		1998	E	
		1999	F	
		2000	G	
		2001	H	
		2002	J	
		2003	K	
		2004	L	
		2005	M	E
		2006		F
		2007		G
		2008		H
		2009		I
		2010		J
		2011		K
		2012		L
		2013		M
		2014		N
		2015		O

a. Regulated Release Mechanism

- ▶ For First Tank: Disconnect expellant gas pipe or hose from tank. Connect regulator test kit (Part No. 56972) to hose. See Figure 9.

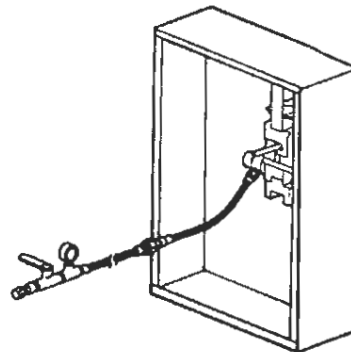

FIGURE 9
000369

For Second Tank: Disconnect expellant gas piping at union. Remove union from expellant gas piping and install pipe cap to prevent cartridge pressure from escaping during test. See Figure 10.

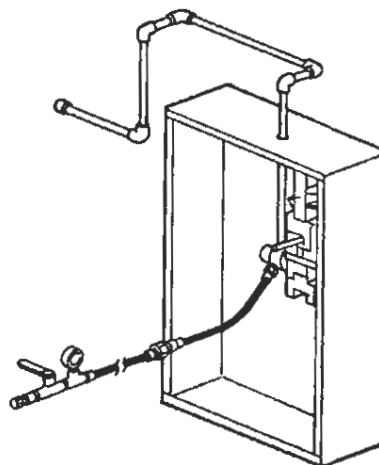

FIGURE 10
000370

▶ Pressure Switch: If an ANSUL supplied pressure switch is still in good operating condition, it should remain connected as part of system maintenance test.

NOTICE

For multiple-tank systems, one test kit (Part No. 56972) is required for each regulator in the system.

12-YEAR MAINTENANCE EXAMINATION (Continued)

b. Regulated Actuator

For First Tank: Disconnect expellant gas hose from tank. Connect regulator test kit (Part No. 56972) to hose. See Figure 11.

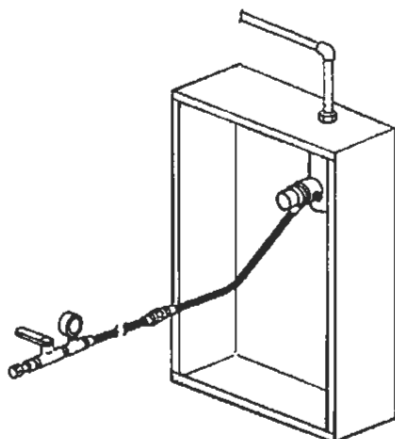

FIGURE 11
000371

For Second Tank: Disconnect expellant gas piping at union. Remove union from expellant gas piping and install pipe cap to prevent cartridge pressure from escaping during test. See Figure 12.

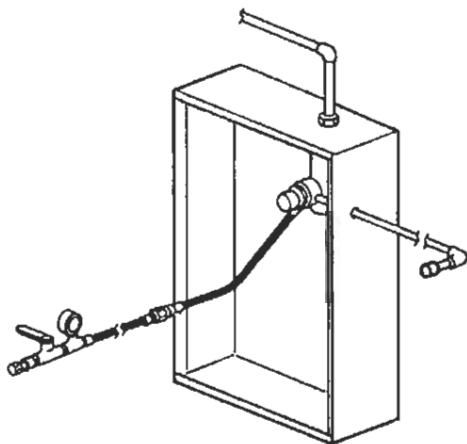

FIGURE 12
000372

NOTICE

Make certain valve is **closed** on regulator test kit or pressure will escape before test can be performed.

- c. Install either a nitrogen or CO₂ cartridge into release mechanism and each regulated actuator provided with the system. (Cartridge should be conditioned to approximately 70 °F (21 °C) before test.)

NOTICE

Before continuing with Step d, make certain valve on test kit is closed.

- d. Remove lock bar and operate remote manual pull station to actuate the regulated release and supply pressure to each test kit.

Two styles of regulators are used with the R-102 release mechanisms. The diaphragm style (see Figure 13) was used in R-102 systems up to approximately 1988. The piston style (see Figure 13) has been used since 1988. Each style requires a slightly different flow test procedure. Use the appropriate flow test procedure as stated in Step e.

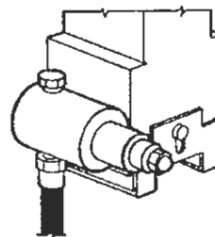

DIAPHRAGM STYLE
(USED UNTIL 1988)

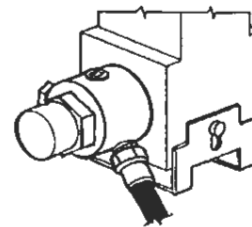

PISTON STYLE
(USED AFTER 1988)

FIGURE 13
002301

- e. Flow test each regulator by completing the following steps:

Diaphragm Style – The correct pressure should read 90 to 110 psi (6.2 to 7.6 bar) with the valve on the test kit closed and 80 psi (5.5 bar) with the valve on the test kit opened. Keep the valve opened to completely empty the pressure cartridge after pressure test has been verified.

Piston Style – Open the valve on the regulator test kit. The correct pressure should read between 95 to 125 psi (6.6 to 8.6 bar). Keep the valve open to completely empty the pressure cartridge.

If necessary, continue to flow test at each additional regulated actuator. Test each regulated actuator by repeating Step e.

- f. Cock release mechanism using cocking lever (Part No. 14995) and insert lock bar (Part No. 14985).
 - g. Remove empty nitrogen cartridge(s) from release mechanism and each regulated actuator.
 - h. Remove test kit(s) from release mechanism and each regulated actuator.
 - i. If regulator test was not successful, replace regulator.
 - j. Reconnect all expellant gas lines.
 - k. Reset all additional equipment that was operated by release mechanism.
15. Examine threads on each adaptor and tank collar for nicks, burrs, or cross-threading. Clean and coat O-ring with a good grade of extreme temperature grease. Make certain bursting disc is in place and silver side is away from tank. See Figure 14.



FIGURE 14
000364

SECTION VIII – MAINTENANCE EXAMINATION

UL EX3470 ULC EX3470 Page 8-8
REV. 2 7-1-09

12-YEAR MAINTENANCE EXAMINATION (Continued)

- ▶ 16. Examine pick-up tube for signs of damage or corrosion. Replace assembly if needed.
- ▶ 17. Refill each tank with 1.5 (5.8 L) or 3.0 (11.6 L) gallons of only new ANSULEX Low pH Liquid Fire Suppressant. **Note:** Use a funnel with a screen to stop any foreign material from entering the tank.

CAUTION

During filling, the agent temperature should be 60 °F to 80 °F (16 °C to 27 °C). **DO NOT FILL WITH COLD AGENT.** Refer to the "Installation" section, Page 5-2.1 for maximum fill heights for ANSULEX Low pH agent storage tanks. **DO NOT OVERFILL.** Overfilling may result in agent entering gas hose and regulator, potentially causing system malfunction.

- ▶ 18. Clean seating surface and return each adaptor/tube assembly to tank. Firmly tighten.

NOTICE

Do not reinstall any tank at this time.

- ▶ 19. Remove blow-off caps from nozzles. Inspect each blow-off cap and replace if deteriorated. On metal blow-off caps, make certain spring clip rotates freely on cap.

NOTICE

Rubber blow-off caps that have been installed in the system for one year or more must be replaced.

- ▶ 20. Check all nozzles to ensure that they are free of cooking grease build-up and have a covering of clean silicone grease on the orifice. Reinstall blow-off caps.
- ▶ 21. Remove lock bar and manually test the regulated release assembly by operating the remote manual pull station.
- ▶ 22. Cock the regulated release mechanism using cocking lever (Part No. 14995 or 435603). See Figure 15.

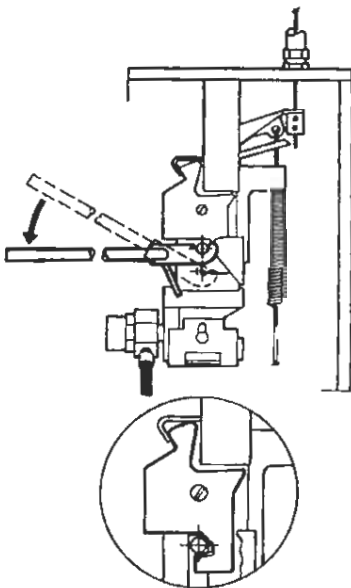

FIGURE 15
000320

- ▶ 23. Raise the tension lever to "UP" position. See Figure 16.

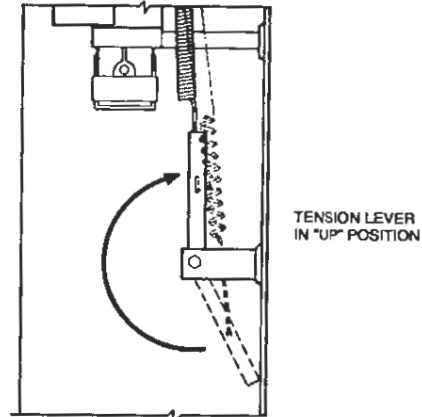

FIGURE 16
000362

- ▶ 24. Install test link (Part No.15751) in terminal detector.
- ▶ 25. Lower tension lever to "DOWN" position. See Figure 17.

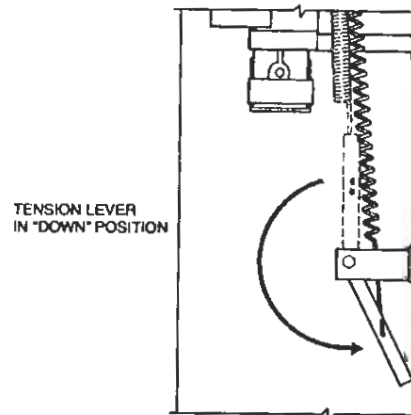

FIGURE 17
001096

- ▶ 26. Using wire cutter, cut test link at terminal detector to simulate automatic actuation.

NOTICE

If regulated release mechanism does not actuate, refer to Steps 2 and 3 of "Testing Detection System" in "Testing and Placing in Service," Section 6.

- ▶ 27. After successful actuation, raise the tension lever to "UP" position.
- ▶ 28. Remove and destroy all existing fusible links from the terminal and series detector brackets and replace with properly-rated ANSUL approved, fusible links in accordance with NFPA 17A.

12-YEAR MAINTENANCE EXAMINATION (Continued)

- ▶ 29. Lower tension lever to "DOWN" position.
- ▶ 30. Recock the regulated release mechanism and insert lock bar.
- ▶ 31. Inspect the base of the wire rope locking clamp to make certain that there is a minimum of 1/4 in. (6.4 mm) and a maximum of 3/8 in. (9.5 mm) clearance between the base of the trip hammer locking clamp assembly and the cable lever assembly. See Figure 18.

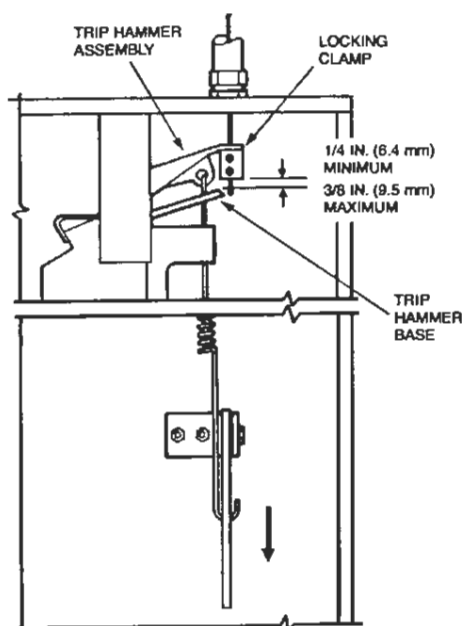

FIGURE 18
000129

NOTICE

If clearance is not between 1/4 in. (6.4 mm) or 3/8 in. (9.5 mm), raise tension lever to "UP" position, raise trip hammer 3/8-1/2 in. (9.5-12.7 mm), tighten set screws, and repeat Steps 29 and 31.

- ▶ 32. Locate detector linkage and properly position in each bracket.
- ▶ 33. Make certain additional devices have operated as intended.
- ▶ 34. Before reinstalling cartridge, reset all additional equipment by referring to appropriate section of "Recharge and Resetting Procedures," Section 7.
- ▶ 35. Place each fully charged tank in enclosure and/or bracket and secure.
- ▶ 36. Reconnect all distribution piping and expellant gas piping unions as required. Wrench tighten.
- ▶ 37. Check each gas cartridge by removing shipping cap and weighing cartridge. Replace if weight is 1/2 ounce (14.2 g), or more, below weight stamped on cartridge.
- ▶ 38. Make certain regulated release mechanism is cocked and lock bar is installed, then screw replacement cartridge into regulated release mechanism and each regulated actuator receiver(s) and hand tighten.
- ▶ 39. Remove lock bar.
- ▶ 40. Install cover on regulated release assembly and each regulated actuator assembly and secure with appropriate fasteners or visual inspection seal. Insert seal (Part No. 197) in each upper and lower cover hole, if applicable. If system is installed in an OEM enclosure, attach enclosure cover and secure with appropriate hardware or procedure.
- ▶ 41. Record date of 12 year maintenance examination on tag attached to enclosure and/or in a permanent file.

CAUTION

Before installing cover, make certain tension lever is in the "DOWN" position after completing all tests. Failure to put the tension lever in the "DOWN" position will cause the system to not operate automatically.

NOTES:

SYSTEM SELECTION GUIDE

► **Note: System options do not cover all conceivable/acceptable variations.** They are listed here as a general guideline to show the most common type arrangement for multiple systems, Based on certain system designs utilizing manifolding, non-manifolding, 3-tank systems, etc., other tank/cartridge combinations can be designed. The combinations below are based on 11 flow, 3.0 gallon tanks and 5 flow, 1.5 gallon tanks. More competitive designs may be available by utilizing 12 flow and 6 flow systems when appropriate.

Total Flow No.*	Tank Quantity	Type of System	Type of Hardware	Carbon Dioxide Cartridge Required	Nitrogen Cartridge Required
1-5	1	Single	1.5 Gal. Reg. Release	101-10 (423439)	LT-20-R (423429)
6-11	1	Single	3.0 Gal. Reg. Release	101-20 (423441)	LT-30-R (423435)
12-16	2	Double	1.5 Gal. Reg. Release 3.0 Gal. Additional Tank	101-30 (423443)	Double (423493)
▶ 16-22	2	Manifold	3.0 Gal. Reg. Release 3.0 Gal. Additional Tank	—	Double (423493)
17-22	2	Double	3.0 Gal. Reg. Release 3.0 Gal. Additional Tank	101-30 (423443)**	Double (423493)
▶ 22-33	3	Multiple	3.0 Gal. Reg. Release 3.0 Gal. Reg. Actuator 3.0 Gal. Additional Tank	—	Double (423493)
23-33	3	Multiple	3.0 Gal. Reg. Release 3.0 Gal. Reg. Actuator 3.0 Gal. Additional Tank	101-20 (423441) 101-30 (423443)***	LT-30-R (423435) LT-A-101-30 (423491)
23-27 (Optional)	3	Multiple	1.5 Gal. Reg. Release 3.0 Gal. Reg. Actuator 3.0 Gal. Additional Tank	101-10 (423439) 101-30 (423443)***	LT-20-R (423429) LT-A-101-30 (423491)
28-33 (Optional)	3	Multiple	3.0 Gal. Reg. Release (2) 3.0 Gal. Additional Tanks	N/A	Double (423493)
34-38	4	Multiple	1.5 Gal. Reg. Release 3.0 Gal. Reg. Actuator Double 3.0 Gal. Tank Box	101-10 (423439) N/A	LT-20-R (423435) LT-A-101-30 (423491)
34-38 (Optional)	4	Multiple	1.5 Gal. Reg. Release 3.0 Gal. Additional Tank 3.0 Gal. Reg. Actuator 3.0 Gal. Additional Tank	101-30 (423443) 101-30 (423443)***	Double (423493) LT-A-101-30 (423491)
39-44	4	Multiple	3.0 Gal. Reg. Release 3.0 gal. Reg. Actuator Double 3.0 Gal. Tank Box	101-20 (423441) N/A	LT-30-R (423435) LT-A-101-30 (423491)
39-44 (Optional)	4	Multiple	3.0 Gal. Reg. Release 3.0 Gal. Additional Tank 3.0 Gal. Reg. Actuator 3.0 Gal. Additional Tank	101-30 (423443)** 101-30 (423443)***	Double (423493) LT-A-101-30 (423491)
45-49	5	Multiple	1.5 Gal. Reg. Release 3.0 Gal. Additional Tank 3.0 Gal. Reg. Actuator Double 3.0 Gal. Tank Box	101-30 (423443) N/A	Double (423493) LT-A-101-30 (423491)
45-49 (Optional)	5	Multiple	1.5 Gal. Reg. Release 3.0 Gal. Reg. Actuator 3.0 Gal. Additional Tank 3.0 Gal. Reg. Actuator 3.0 Gal. Additional Tank	101-10 (423439) 101-30 (423443)*** 101-30 (423443)***	LT-20-R (423429) LT-A-101-30 (423491) LT-A-101-30 (423491)

* Based on 5 flow numbers for a 1.5 gal system and 11 flow numbers for a 3.0 gal. system.
 ** If tanks are manifolded, only a "double tank" nitrogen cartridge (Part No. 423493) can be used.
 *** If tanks are manifolded, either an LT-A-101-30 nitrogen cartridge (Part No. 423491) or a double tank cartridge (Part No. 423493) can be used.

SECTION IX – APPENDIX

SYSTEM SELECTION GUIDE (Continued)

Total Flow No.*	Tank Quantity	Type of System	Type of Hardware	Carbon Dioxide Cartridge Required	Nitrogen Cartridge Required
50-55	5	Multiple	3.0 Gal. Reg. Release 3.0 Gal. Additional Tank 3.0 Reg. Actuator Double 3.0 Gal. Tank Box	101-30 (423443) N/A	Double (423493) LT-A-101-30 (423491)
50-55 (Optional)	5	Multiple	3.0 Gal. Reg. Release 3.0 Gal. Reg. Actuator 3.0 Gal. Additional Tank 3.0 Gal. Reg. Actuator 3.0 Gal. Additional Tank	101-20 (423441) 101-30 (423443)*** 101-30 (423443)***	LT-30-R (423435) LT-A-101-30 (423491) LT-A-101-30 (423491)
56-60	6	Multiple	1.5 Gal. Reg. Release 3.0 Gal. Additional Tank 3.0 Gal. Reg. Actuator 3.0 Gal. Additional Tank 3.0 Gal. Reg. Actuator 3.0 Gal. Additional Tank	101-30 (423443) 101-30 (423443)*** 101-30 (423443)***	Double (423493) LT-A-101-30 (423491) LT-A-101-30 (423491)
61-66	6	Multiple	3.0 Gal. Reg. Release 3.0 Gal. Additional Tank 3.0 Gal. Reg. Actuator 3.0 Gal. Additional Tank 3.0 Gal. Reg. Actuator 3.0 Gal. Additional Tank	101-30 (423443)** 101-30 (423443)*** 101-30 (423443)***	Double (423493) LT-A-101-30 (423491) LT-A-101-30 (423491)
67-71	7	Multiple	1.5 Gal. Reg. Release (2) 3.0 Gal. Reg. Actuator (2) Double 3.0 Gal. Tank Box	101-10 (423439) N/A	LT-20-R (423429) (2) LT-A-101-30 (423491)
67-71 (Optional)	7	Multiple	Remote Mechanical Release 3.0 Gal. Reg. Actuator 1.5 Gal. Additional Tank 3.0 Gal. Reg. Actuator 3.0 Gal. Additional Tank 3.0 Gal. Reg. Actuator 3.0 Gal. Additional Tank 3.0 Gal. Reg. Actuator	101-10 (423439) 101-30 (423443) 101-30 (423443)*** 101-30 (423443)*** 101-20 (423441)***	-- LT-A-101-30 (423491) LT-A-101-30 (423491) LT-A-101-30 (423491) LT-30-R (423435)
72-77	7	Multiple	3.0 Gal. Reg. Release (2) 3.0 Gal. Reg. Actuator (2) Double 3.0 Gal. Tank Box	101-20 (423441) N/A	LT-30-R (423435) (2) LT-A-101-30 (423491)
72-77 (Optional)	7	Multiple	Remote Mechanical Release 3.0 Gal. Reg. Actuator 3.0 Gal. Additional Tank 3.0 Gal. Reg. Actuator 3.0 Gal. Additional Tank 3.0 Gal. Reg. Actuator 3.0 Gal. Additional Tank 3.0 Gal. Reg. Actuator	101-10 (423439) 101-30 (423443)*** 101-30 (423443)*** 101-30 (423443)*** 101-20 (423441)	-- LT-A-101-30 (423491) LT-A-101-30 (423491) LT-A-101-30 (423491) LT-30-R (423435)

* Based on 5 flow numbers for a 1.5 gal. system and 11 flow numbers for a 3.0 gal. system.
 ** If tanks are manifolded, only a "double tank" nitrogen cartridge (Part No. 423493) can be used.
 *** If tanks are manifolded, either an LT-A-101-30 nitrogen cartridge (Part No. 423491) or a double tank cartridge (Part No. 423493) can be used.

SYSTEM SELECTION GUIDE (Continued)

Total Flow No.*	Tank Quantity	Type of System	Type of Hardware	Carbon Dioxide Cartridge Required	Nitrogen Cartridge Required
78-82	8	Multiple	1.5 Gal. Reg. Release 3.0 Gal. Additional Tank (2) 3.0 Gal. Reg. Actuator (2) Double 3.0 Gal. Tank Box	101-30 (423443) N/A	LT-30-R (423435) (2) LT-A-101-30 (423491)
78-82 (Optional)	8	Multiple	Remote Mechanical Release 3.0 Gal. Reg. Actuator 1.5 Gal. Additional Tank 3.0 Gal. Reg. Actuator 3.0 Gal. Additional Tank 3.0 Gal. Reg. Actuator 3.0 Gal. Additional Tank 3.0 Gal. Reg. Actuator 3.0 Gal. Additional Tank	101-10 (423439) 101-30 (423443) 101-30 (423443)*** 101-30 (423443)*** 101-30 (423443)*** 101-30 (423443)***	-- LT-A-101-30 (423491) LT-A-101-30 (423491) LT-A-101-30 (423491) LT-A-101-30 (423491)
83-88	8	Multiple	3.0 Gal. Reg. Release 3.0 Gal. Additional Tank (2) 3.0 Gal. Reg. Actuator (2) Double 3.0 Gal. Tank Box	101-30 (423443) N/A	LT-30-R (423435) (2) LT-A-101-30 (423491)
83-88 (Optional)	8	Multiple	Remote Mechanical Release 3.0 Gal. Reg. Actuator 3.0 Gal. Additional Tank 3.0 Gal. Reg. Actuator 3.0 Gal. Additional Tank 3.0 Gal. Reg. Actuator 3.0 Gal. Additional Tank 3.0 Gal. Reg. Actuator 3.0 Gal. Additional Tank	101-10 (423439) 101-30 (423443)*** 101-30 (423443)*** 101-30 (423443)*** 101-30 (423443)*** 101-30 (423443)***	-- LT-A-101-30 (423491) LT-A-101-30 (423491) LT-A-101-30 (423491) LT-A-101-30 (423491)
89-99	9	Multiple	Remote Mech. Release (3) 3.0 Gal. Reg. Actuator (3) Double 3.0 Gal. Tank Box	101-10 (423439) N/A	N/A (3) LT-A-101-30 (423491)
89-93 (Optional)	9	Multiple	Remote Mechanical Release 3.0 Gal. Reg. Actuator 3.0 Gal. Additional Tank 3.0 Gal. Reg. Actuator 3.0 Gal. Additional Tank 3.0 Gal. Reg. Actuator 3.0 Gal. Additional Tank 3.0 Gal. Reg. Actuator 1.5 Gal. Additional Tank 3.0 Gal. Reg. Actuator	101-10 (423439) 101-30 (423443)*** 101-30 (423443)*** 101-30 (423443)*** 101-30 (423443)*** 101-30 (423443)*** 101-30 (423443)*** 101-20 (423441)	-- LT-A-101-30 (423491) LT-A-101-30 (423491) LT-A-101-30 (423491) LT-A-101-30 (423491) LT-A-101-30 (423491) LT-30-R (423435)
94-99 (Optional)	9	Multiple	Remote Mechanical Release 3.0 Gal. Reg. Actuator 3.0 Gal. Additional Tank 3.0 Gal. Reg. Actuator 3.0 Gal. Additional Tank 3.0 Gal. Reg. Actuator 3.0 Gal. Additional Tank 3.0 Gal. Reg. Actuator 3.0 Gal. Additional Tank	101-10 (423439) 101-30 (423443)*** 101-30 (423443)*** 101-30 (423443)*** 101-30 (423443)*** 101-30 (423443)*** 101-30 (423443)*** 101-20 (423441)	-- LT-A-101-30 (423491) LT-A-101-30 (423491) LT-A-101-30 (423491) LT-A-101-30 (423491) LT-A-101-30 (423491) LT-30-R (423435)

* Based on 5 flow numbers for a 1.5 gal. system and 11 flow numbers for a 3.0 gal. system.

** If tanks are manifolded, only a "double tank" nitrogen cartridge (Part No. 423493) can be used.

*** If tanks are manifolded, either an LT-A-101-30 nitrogen cartridge (Part No. 423491) or a double tank cartridge (Part No. 423493) can be used.

SYSTEM SELECTION GUIDE (Continued)

Total Flow No.*	Tank Quantity	Type of System	Type of Hardware	Carbon Dioxide Cartridge Required	Nitrogen Cartridge Required
100-110	10	Multiple	Remote Mech. Release (3) 3.0 Gal. Reg. Actuator (3) Double 3.0 Gal. Tank Box 3.0 Gal. Reg. Actuator	101-10 (423439) N/A 101-20 (423441)	N/A (3) LT-A-101-30 (423491) LT-30-R (423435)
100-104 (Optional)	10	Multiple	Remote Mechanical Release 3.0 Gal. Reg. Actuator 1.5 Gal. Additional Tank 3.0 Gal. Reg. Actuator 3.0 Gal. Additional Tank 3.0 Gal. Reg. Actuator 3.0 Gal. Additional Tank 3.0 Gal. Reg. Actuator 3.0 Gal. Additional Tank 3.0 Gal. Reg. Actuator 3.0 Gal. Additional Tank	101-10 (423439) 101-30 (423443) 101-30 (423443)*** 101-30 (423443)*** 101-30 (423443)*** 101-30 (423443)*** 101-30 (423443)*** 101-30 (423443)***	-- LT-A-101-30 (423491) LT-A-101-30 (423491) LT-A-101-30 (423491) LT-A-101-30 (423491) LT-A-101-30 (423491) LT-A-101-30 (423491)
100-104 (Optional)	10	Multiple	Remote Mech. Release (2) 3.0 Gal. Reg. Actuator (2) Double 3.0 Gal. Tank Box (2) 3.0 Gal. Reg. Actuator 3.0 Gal. Additional Tank 1.5 Gal. Additional Tank	101-10 (423439) N/A (2) 101-30 (423443)	N/A (2) LT-A-101-30 (423491) (2) LT-A-101-30 (423491)
105-110 (Optional)	10	Multiple	Remote Mechanical Release 3.0 Gal. Reg. Actuator 3.0 Gal. Additional Tank 3.0 Gal. Reg. Actuator 3.0 Gal. Additional Tank 3.0 Gal. Reg. Actuator 3.0 Gal. Additional Tank 3.0 Gal. Reg. Actuator 3.0 Gal. Additional Tank 3.0 Gal. Reg. Actuator 3.0 Gal. Additional Tank	101-10 (423439) 101-30 (423443)*** 101-30 (423443)*** 101-30 (423443)*** 101-30 (423443)*** 101-30 (423443)*** 101-30 (423443)*** 101-30 (423443)***	-- LT-A-101-30 (423491) LT-A-101-30 (423491) LT-A-101-30 (423491) LT-A-101-30 (423491) LT-A-101-30 (423491) LT-A-101-30 (423491)

* Based on 5 flow numbers for a 1.5 gal. system and 11 flow numbers for a 3.0 gal. system.
 ** If tanks are manifolded, only a "double tank" nitrogen cartridge (Part No. 423493) can be used.
 *** If tanks are manifolded, either an LFA-101-30 nitrogen cartridge (Part No. 423491) or a double tank cartridge (Part No. 423493) can be used.

Options are available up to a maximum of 15 tanks. Contact ANSUL Technical Services Department for detailed information.

SYSTEM COMPONENT INDEX

Part No.	Description	Part No.	Description
429853 (ULC Also)	Mechanical ANSUL AUTOMAN Regulated Release Shipping Assembly Includes: Regulated Release Mechanism in Stainless Steel Mounting Enclosure	418054	OEM Regulated Electric Release Shipping Assembly Includes: Regulated Release Mechanism with Solenoid and Switch 1/4 in. Hose and Mounting Bracket
429856	Electric ANSUL AUTOMAN Regulated Release Shipping Assembly Includes: Regulated Release Mechanism with Solenoid and Switch in Stainless Steel Mounting Enclosure	79493	OEM Regulated Mechanical Release Shipping Assembly Includes: Regulated Release Mechanism 1/4 in. Hose and Mounting Bracket
429850 (ULC Also)	Regulated Actuator Shipping Assembly Includes: Actuator and Regulator in Stainless Steel Mounting Enclosure	418691	OEM Regulated Actuator Shipping Assembly Includes: Actuator and Regulator Hose Bracket
429870 (ULC Also)	Stainless Steel Mounting Box Shipping Assembly Includes: Stainless Steel Mounting Box	429878	3.0 Gallon Bracket Assembly (Bracket Only)
429872 (ULC Also)	Two Tank Enclosure Shipping Assembly Includes: Two (2) Expellant Gas Hoses Two (2) Grommets Stainless Steel Mounting Box	▶ 433485	Remote Release Assembly
429859 (ULC)	24 VDC Regulated Release Shipping Assembly Includes: 24 VDC ANSUL AUTOMAN II-C Release Mechanism in Stainless Steel Mounting Box	418522	OEM Regulated Actuator Shipping Assembly Includes: Actuator and Regulator Hose
430299	3.0 Gallon Mechanical Release Shipping Assembly including: 429853 Mechanical Regulated Release Assembly 429862 3.0 Gallon Tank Assembly	429862	3.0 Gallon Tank Shipping Assembly
430300	1.5 Gallon Mechanical Release Shipping Assembly including 429853 Mechanical Regulated Release Assembly 429864 1.5 Gallon Tank Assembly	429864	1.5 Gallon Tank Shipping Assembly
430309	3.0 Gallon Regulated Actuator Shipping Assembly including: 429850 Regulated Actuator Assembly 429862 3.0 Gallon Tank Assembly	56972	Regulator Test Kit Includes: Gauge, Hose and Valve Assembly
430316	1.5 Gallon Stainless Steel Enclosure Shipping Assembly including: 429870 Single Tank Mounting Box Assembly 429864 1.5 Gallon Tank Assembly	79694	1.5 Gallon (5.8 L) Container of ANSULEX Low pH Liquid Fire Suppressant
430317	3.0 Gallon Stainless Steel Enclosure Shipping Assembly including: 429870 Single Tank Mounting Box Assembly 429862 3.0 Gallon Tank Assembly	79372	3.0 Gallon (11.6 L) Container of ANSULEX Low pH Liquid Fire Suppressant
430324	6.0 Gallon Stainless Steel Enclosure Shipping Assembly including: 429872 Two Tank Mounting Box Assembly 429862 3.0 Gallon Tank Assembly (2)	423429	Cartridge Shipping Assembly (LT-20-R) (TC/DOT)
430332	3.0 Gallon Mounting Bracket Shipping Assembly including: 429878 3.0 Gallon Mounting Bracket Assembly 429862 3.0 Gallon Tank Assembly	423435	Cartridge Shipping Assembly (LT-30-R) (TC/DOT)
		423493	Cartridge Shipping Assembly (R-102 Double-Tank) (TC/DOT)
		423491	Cartridge Shipping Assembly (LT-A-101-30) (TC/DOT)
		423439	Cartridge Shipping Assembly (101-10) (TC/DOT)
		15850	Cartridge Shipping Assembly (101-10) (DOT)
		423441	Cartridge Shipping Assembly (101-20) (TC/DOT)
		423443	Cartridge Shipping Assembly (101-30) (TC/DOT)
		▶ 428440	Cartridge Shipping Assembly (LT-20-R) (European)
		428441	Cartridge Shipping Assembly (LT-30-R) (European)
		428446	Cartridge Shipping Assembly (R-102 Double Tank) (European)
		▶ 428442	Cartridge Shipping Assembly (LT-A-101-30) (European)

SECTION IX -- APPENDIX

UL EX3470 ULC EX3470 Page 9-6

REV. 7 7-1-09

SYSTEM COMPONENT INDEX (Continued)

Part No.	Description	Part No.	Description
428443	Cartridge Shipping Assembly (101-10) (European)	423572	Swivel Adaptor Shipping Assembly Includes: 25 Swivel Adaptors (Part No. 418569)
428445	Cartridge Shipping Assembly (101-20) (European)	77695	Blow-Off Cap Shipping Assembly (Spare) Includes: 50 Blow-Off Caps (Part No. 77676)
428444	Cartridge Shipping Assembly (101-30) (European)	77411	Blow-Off Cap Shipping Assembly Includes: 12 Blow-Off Caps (Part No. 77676)
428948	Cartridge Shipping Assembly (LT-20-R) (Australian)	433208	CB Metal Blow-Off Cap Shipping Assembly Includes: 10 Blow-Off Caps (Part No. 432153)
426553	Cartridge Shipping Assembly (LT-30-R) (Australian)	434707	CB Stainless Steel Blow-Off Cap Shipping Assembly Includes: 10 Blow-Off Caps (Part No. 435224)
426563	Cartridge Shipping Assembly (R-102 Double Tank) (Australian)	551530	Metal Blow-Off Cap O-Ring Shipping Assembly Includes: 10 O-Rings (Part No. 550625)
426555	Cartridge Shipping Assembly (LT-A-101-30) (Australian)	417911	In-Line Burst Disc Shipping Assembly Includes: 10 Burst Discs (Part No. 416970)
419347	Nozzle Shipping Assembly (1W) Includes: 25 1W Nozzles (Part No. 419336) 25 Blow-Off Caps	25627	1/4 in. Check Valve
419345	Nozzle Shipping Assembly (1/2N) Includes: 9 1/2N Nozzles (Part No. 419334) 9 Blow-Off Caps	551265	Nozzle Aiming Device
419346	Nozzle Shipping Assembly (1N) Includes: 25 1N Nozzles (Part No. 419335) 25 Blow-Off Caps	435547	Series Detector Package ("Scissor")
419349	Nozzle Shipping Assembly (3N) Includes: 9 3N Nozzles (Part No. 419338) 9 Blow-Off Caps	435548	Series Detector, Pack of 25 ("Scissor")
419348	Nozzle Shipping Assembly (2W) Includes: 25 2W Nozzles (Part No. 419337) 25 Blow-Off Caps	435546	Terminal Detector Package ("Scissor") Includes: Test Link
419350	Nozzle Shipping Assembly (230) Includes: 25 230 Nozzles (Part No. 419339) 25 Blow-Off Caps	415671	Pulley Elbows Shipping Assembly (Socket End) – to 700 °F (371 °C) Includes: 50 Elbows (Part No. 415670)
419351	Nozzle Shipping Assembly (245) Includes: 25 245 Nozzles (Part No. 419340) 25 Blow-Off Caps	423251	Pulley Elbows Shipping Assembly (Compression End) – to 700 °F (371 °C) Includes: 50 Elbows (Part No. 423250)
419352	Nozzle Shipping Assembly (260) Includes: 9 260 Nozzles (Part No. 419341) 9 Blow-Off Caps	427929	Pulley Tee
418353	Nozzle Shipping Assembly (290) Includes: 9 290 Nozzles (Part No. 419342) 9 Blow-Off Caps	15821	Wire Rope (50 Feet (15 m))
419354	Nozzle Shipping Assembly (2120) Includes: 9 2120 Nozzles (Part No. 419343) 9 Blow-Off Caps	79653	Wire Rope (500 Feet (152 m))
419344	Nozzle Shipping Assembly (1F) Includes: 9 1F Nozzles (Part No. 419333) 9 Blow-Off Caps	24919	Stop Sleeve Package Includes: 10 Stop Sleeves (Part No. 26317)
435672	Stainless Steel Nozzle Shipping Assembly (1N) Includes: 1 Blow-Off Cap (Part No. 77676)	550122	Oval Sleeve Package Includes: 100 Oval Sleeves (Part No. 4596)
432527	Stainless Steel Nozzle Shipping Assembly (1W) Includes: 1 Blow-Off Cap (Part No. 77676)	436063	Conduit Offset Shipping Assembly Includes: 6 Conduit Offsets (Part No. 435961)
419385	Swivel Adaptor Shipping Assembly Includes: 9 Swivel Adaptors (Part No. 418569)	78196	1/4 in. "Quik-Seal" Adaptor Package Includes: 24 "Quik-Seals" (Part No. 78195)
		77285	3/8 in. "Quik-Seal" Adaptor Package Includes: 24 "Quik-Seals" (Part No. 77284)
		77287	1/2 in. "Quik-Seal" Adaptor Package Includes: 24 "Quik-Seals" (Part No. 77286)
		77289	3/4 in. "Quik-Seal" Adaptor Package Includes: 24 "Quik-Seals" (Part No. 77288)

SYSTEM COMPONENT INDEX (Continued)

<u>Part No.</u>	<u>Description</u>	<u>Part No.</u>	<u>Description</u>
79149	1/4 in. "Compression-Seal" Pipe Adaptor Package Includes: 24 "Compression-Seals" (Part No. 79148)	423879	Two Electric Switch (Field Mounted) Kit Includes: 2 Electric Switches (SPDT), Mounting Hardware
79151	3/8 in. "Compression-Seal" Pipe Adaptor Package Includes: 24 "Compression-Seals" (Part No. 79150)	423880	Three Electric Switch (Field Mounted) Kit Includes: 3 Electric Switches (SPDT), Mounting Hardware
79147	1/2 in. "Compression-Seal" Pipe Adaptor Package Includes: 24 "Compression-Seals" (Part No. 79146)	423881	Four Electric Switch (Field Mounted) Kit Includes: 4 Electric Switches (SPDT), Mounting Hardware
79153	1/2 in. "Compression-Seal" EMT Conduit Adaptor Package Includes: 24 "Compression-Seals" (Part No. 79152)	428311	Alarm Initiating Switch Kit
423253	Hood Seal Adaptor Shipping Assembly Includes: 6 Hood Seals	55598	Gas Shut-off Equipment Mechanical (ANSUL) Includes: Mechanical Gas Valve – 3/4 in.
▶ 436228	Reducing Coupling	55601	Gas Shut-off Equipment Mechanical (ANSUL) Includes: Mechanical Gas Valve – 1 in.
435603	Short Handle Cocking Lever (Mechanical/Electrical ANSUL AUTOMAN)	55604	Gas Shut-off Equipment Mechanical (ANSUL) Includes: Mechanical Gas Valve – 1 1/4 in.
435790	Short Handle Cocking Lever with Lock Bar (Mechanical/Electrical ANSUL AUTOMAN)	55607	Gas Shut-off Equipment Mechanical (ANSUL) Includes: Mechanical Gas Valve – 1 1/2 in.
14995	Long Handle Cocking Lever (Mechanical/Electrical ANSUL AUTOMAN)	55610	Gas Shut-off Equipment Mechanical (ANSUL) Includes: Mechanical Gas Valve – 2 in.
15618	Long Handle Cocking Lever with Lock Bar (Mechanical/Electrical ANSUL AUTOMAN)	25937	Gas Shut-off Equipment Mechanical (ASCO) Includes: Mechanical Gas Valve – 2 1/2 in.
26310	Cocking Lever (ANSUL AUTOMAN II-C)	25938	Gas Shut-off Equipment Mechanical (ASCO) Includes: Mechanical Gas Valve – 3 in.
416018	Cocking Lever (Mechanical Gas Valve)	15733	Gas Shut-off Equipment Includes: Air Cylinder and Tube Assembly
▶ 14985	Lock Bar	13707	Gas Shut-off Equipment (Electrical 110 VAC, 60 Hz) Includes: Solenoid Valve – 3/4 in.
13707	Gas Shut-off Equipment (Electrical 110 VAC, 60 Hz) Includes: Solenoid Valve – 3/4 in.	▶ 434618	Remote Manual Pull Station Assembly
13708	Gas Shut-off Equipment (Electrical 110 VAC, 60 Hz) Includes: Solenoid Valve – 1 in.	435960	Remote Manual Pull Station Assembly Includes: 50 ft (15.2 m) of Wire Rope
▶ 550360	Gas Shut-off Equipment (Electrical 110 VAC, 60 Hz) Includes: Solenoid Valve – 1 1/4 in.	24915	Break Rod Package Includes: 10 Glass Break Rods (Part No. 4834) (Replacement)
▶ 13709	Gas Shut-off Equipment (Electrical 110 VAC, 60 Hz) Includes: Solenoid Valve – 1 1/2 in.	427074	Trim Rings (Pack of 10)
13710	Gas Shut-off Equipment (Electrical 110 VAC, 60 Hz) Includes: Fluid Power Gas Valve – 2 in.	▶ 434525	Flexible Conduit – 500 ft (152.4 m)
▶ 550363	Gas Shut-off Equipment (Electrical 110 VAC, 60 Hz) Includes: Fluid Power Gas Valve – 2 1/2 in.	435959	Flexible Conduit – 500 ft (152.4 m) Includes: 500 ft (152.4 m) of Wire Rope
▶ 17643	Gas Shut-off Equipment (Electrical 110 VAC, 60 Hz) Includes: Fluid Power Gas Valve – 3 in.	435979	Flexible Conduit Strain Relief Includes: 50 Strain Reliefs
426151	Gas Shut-off Equipment (Electrical 110 VAC, 60 Hz) Includes: Relay – Manual Reset	434347	Flexible Conduit Inserts Includes: 50 Inserts
423878	One Electric Switch (Field Mounted) Kit Includes: Electric Switch (SPDT), Mounting Hardware	31809	16 in. (41 cm) Stainless Steel Actuation Hose
		32335	20 in. (51 cm) Stainless Steel Actuation Hose
		32336	24 in. (61 cm) Stainless Steel Actuation Hose
		430815	42 in. (107 cm) Stainless Steel Actuation Hose
		▶ 435982	Agent Distribution Hose and Restraining Cable Kit

SECTION IX – APPENDIX

UL EX3470 ULC EX3470

Page 9-6.2

REV. 3 7-1-09

SYSTEM COMPONENT INDEX (Continued)

Part No.	Description	Part No.	Description
▶ 434455	Henny Penny Fryer Nozzle Kit	73867	Recharge Equipment Includes: 25 Fusible Links 500 °F (260 °C) (Part No. 56816)
423429	Recharge Equipment Includes: LT-20-R Cartridge	▶ 79651	Recharge Equipment Includes: Detector Bracket – “Scissor”
423435	Recharge Equipment Includes: LT-30-R Cartridge	415817	Recharge Equipment Includes: Detector Linkage – “Scissor”
423493	Recharge Equipment Includes: Double System Cartridge	▶ 14985	Recharge Equipment Includes: Lock Bar
423491	Recharge Equipment Includes: LT-A-101-30 Cartridge	14995	Recharge Equipment Includes: Cocking Lever
423439	Recharge Equipment Includes: 101-10 Cartridge	26310	Recharge Equipment Includes: Cocking Lever for ANSUL AUTOMAN II-C
423441	Recharge Equipment Includes: 101-20 Cartridge	15618	Recharge Equipment Includes: Cocking Lever and Lock Bar Assembly
423443	Recharge Equipment Includes: 101-30 Cartridge	15240	Recharge Equipment Includes: 500 °F (260 °C) Exhaust Duct Thermometer
79372	Recharge Equipment Includes: 3.0 Gallon (11.4 L) Container of ANSULEX Low pH Liquid Fire Suppressant	197	Recharge Equipment Includes: Lead and Wire Seal
79694	Recharge Equipment Includes: 1.5 Gallon (5.7 L) Container of ANSULEX Low pH Liquid Fire Suppressant	418087	Recharge Equipment Includes: Installation Manual
417911	Recharge Equipment Includes: Package of 10 Tank Adaptor Bursting Discs		
77695	Recharge Equipment Includes: 50 Blow-Off Caps		
24916	Recharge Equipment Includes: 10 Test Links (Part No. 15751)		
415739	Recharge Equipment Includes: Fusible Link 165 °F (74 °C)		
415740	Recharge Equipment Includes: Fusible Link 212 °F (100 °C)		
415744	Recharge Equipment Includes: 25 Fusible Links 280 °F (138 °C) (Part No. 415741)		
415745	Recharge Equipment Includes: 25 Fusible Links 360 °F (182 °C) (Part No. 415742)		
415746	Recharge Equipment Includes: 25 Fusible Links 450 °F (232 °C) (Part No. 415743)		

"ANSUL AUTOMAN" REGULATED RELEASE ASSEMBLY

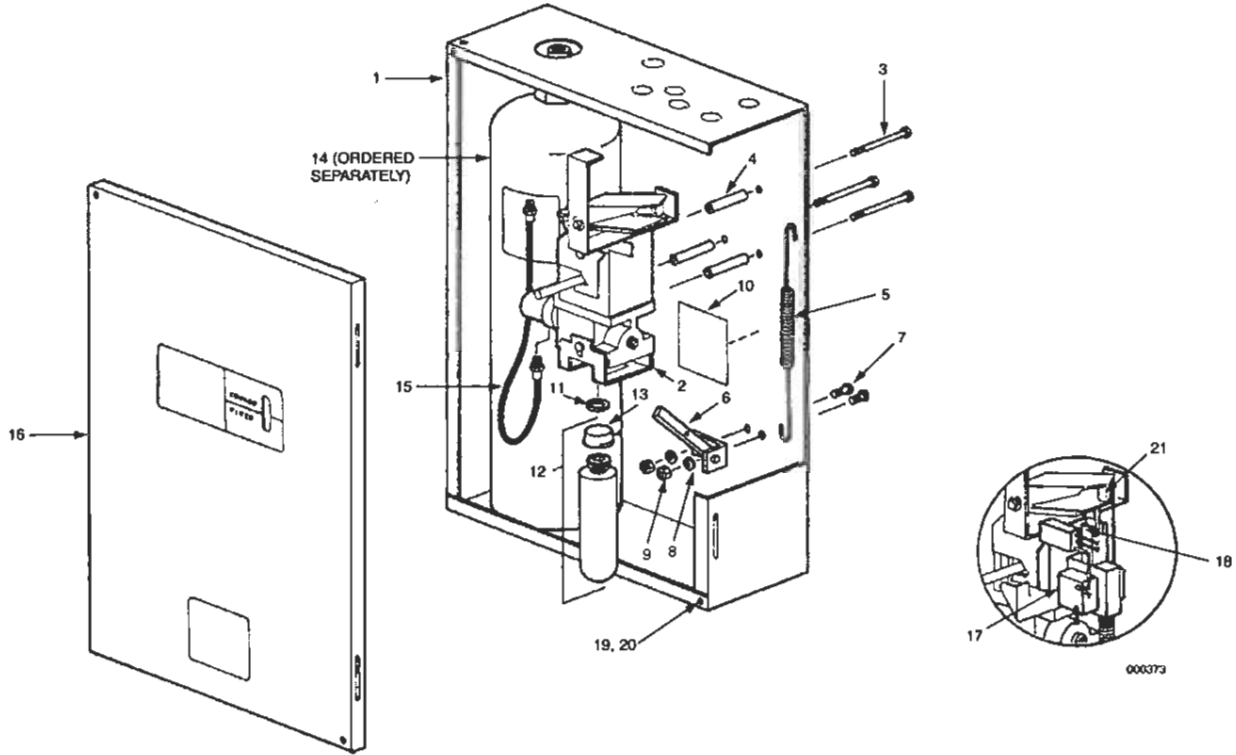

Figure No.	Description	Mechanical Part No.	Electrical Part No.
–	Regulated Release Shipping Assembly	429853	429856
1	Mounting Box	419293	419293
2	Basic Release w/Regulator	79140	–
	Basic Release w/Solenoid, Switch, and Regulator	–	79288
3	Self-Tapping Screw	71342	71342
4	Spacer	76555	76555
5	Tension Spring	79094	79094
6	Lever and Bracket Assembly	79300	79300
7	Machine Screw	14973	14973
8	Lockwasher	7310	7310
9	Hex Nut	14732	14732
10	Caution Label	57652	57652
11	Gasket	181	181
12	Expellant Gas Cartridge Assembly		
	LT-30-R/101-20 (Ordered Separately)	423435/423441	423435/423441
	Double Tank/101-30 (Ordered Separately)	423493/423443	423443/423443
13	Safety Shipping Cap	77251	77251
14	Tank Assembly 1.5/3.0 Gal. (Ordered Separately)	429864/429862	429864/429862
15	Hose Assembly	79007	79007
16	Enclosure Cover (Includes Label)	423744	423744
17	Solenoid Assembly	–	423575
18	Electric Snap-Action Switch	–	423878
19	Cover Screw	15362	15362
20	Speed Nut	423479	423479
▶ 21	Set Screw	73101	73101

REGULATED ACTUATOR ASSEMBLY

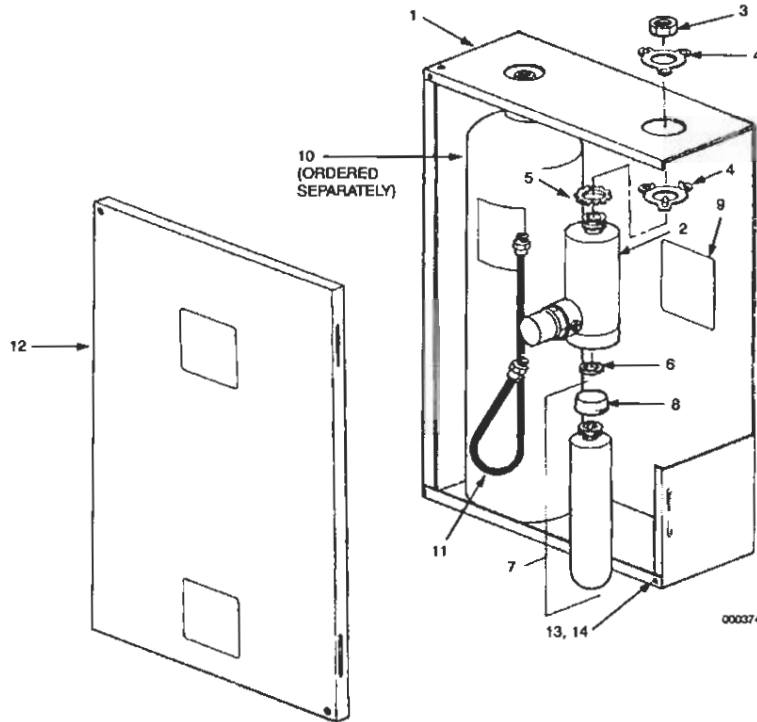

Figure No.	Description	Part No.
-	Regulated Actuator Assembly	429850
1	Mounting Box	419293
2	Pneumatic Actuator Assembly Including Regulator	79340
3	Hex Jam Nut	67990
4	Hole Adaptor (2)	423277
5	Lockwasher	69521
6	Gasket	181
7	Expellant Gas Cartridge Assembly	
	LT-20-R/101-10 (Ordered Separately)	423429/423439
	LT-30-R/101-20 (Ordered Separately)	423435/423441
	Double Tank/101-30 (Ordered Separately)	423493/423443
	LT-A-101-30/101-30 (Ordered Separately)	423491/423443
8	Safety Shipping Cap	77251
9	Label	426953
10	Tank Assembly 1.5/3.0 Gal. (Ordered Separately)	429864/429862
11	Hose Assembly	79007
12	Enclosure Cover (Without Labels)	419294
13	Cover Screw	15362
14	Speed Nut	423479

ENCLOSURE ASSEMBLY

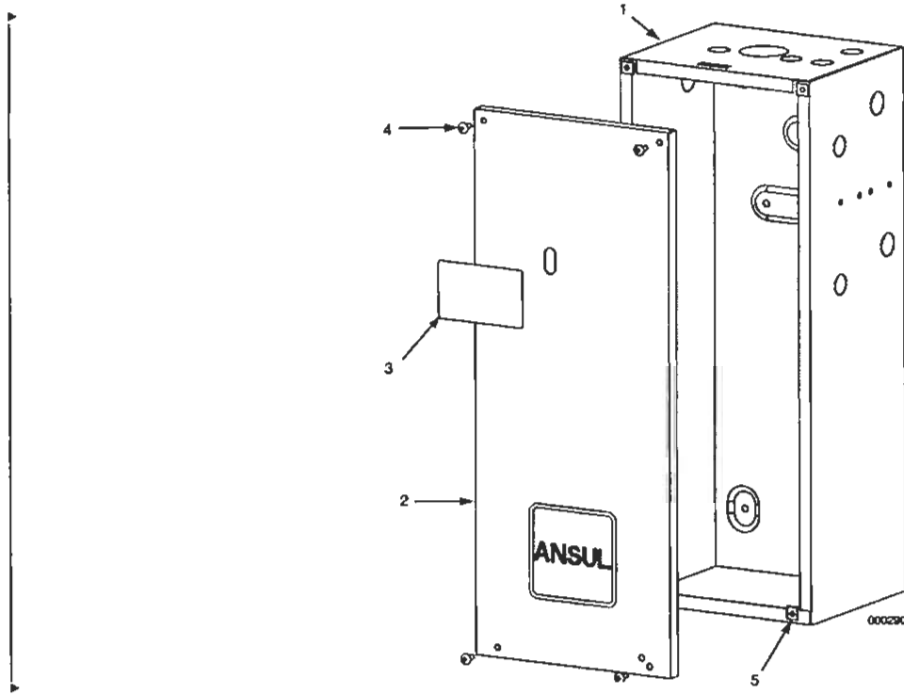

Figure
No.

Description

- Enclosure Shipping Assembly
- 1 Enclosure
- 2 Cover
- 3 Nameplate
- 4 Screw
- 5 Speed Nut

Part No. _____

- 429870
- 419295
- 419296
- 429871
- 15362
- 423479

BRACKET ASSEMBLY

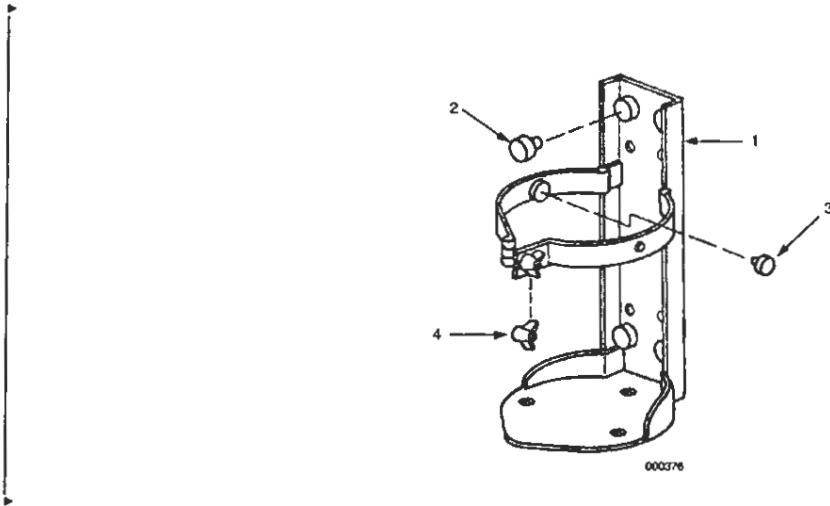

Figure
 No.

Description

—	Bracket Shipping Assembly
1	Bracket Assembly
2	Grommet
3	Grommet
4	Wing Nut

3.0 Gallon
 Part No.

429878
—
14089
8688
12065

TANK ASSEMBLY

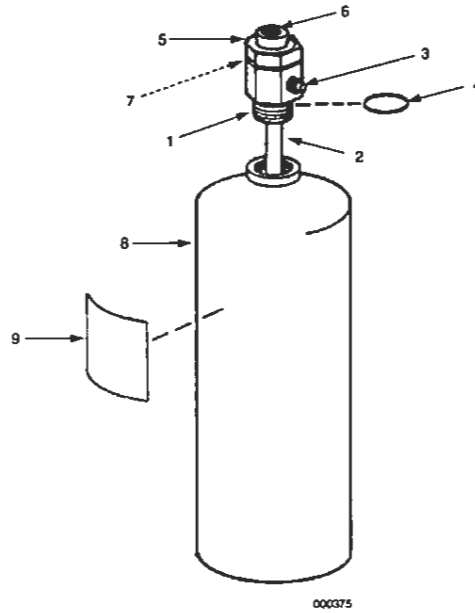

Figure No.	Description	1.5 Gallon Part No.	3.0 Gallon Part No.
-	Tank Assembly	429864	429862
▶ 1	Tank Adaptor Shipping Assembly	430103	79522
2	Pickup Tube Assembly	429883	417700
3	Vent Plug Assembly	74247	74247
4	O-Ring	56909	56909
5	Union Nut	417705	417705
6	Union Tail Piece	417706	417706
7	Burst Disc	416974	416974
8	Shell	429861	429860
9	Nameplate	N/A	N/A

▶ REMOTE RELEASE

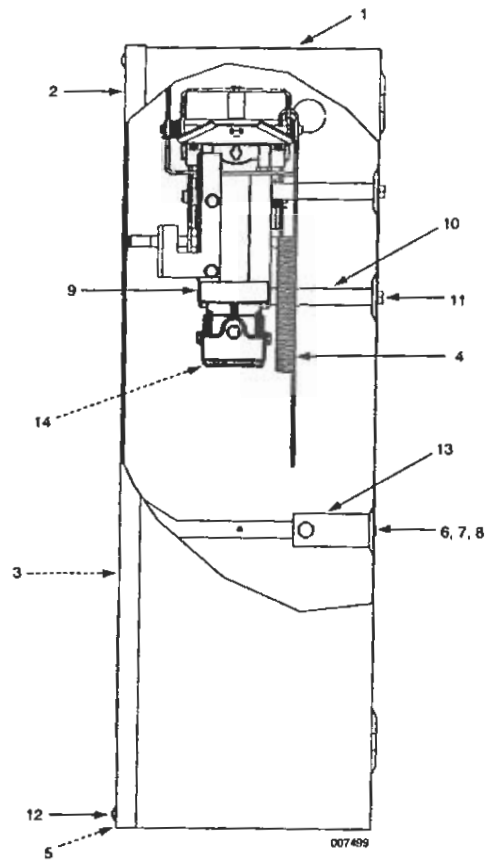

Figure No.	Description	Part No.
—	Remote Release	433485
1	Mounting Box	419295
2	Cover	419296
3	Maintenance Label	17351
4	Spring	79094
5	Speed Nut	423479
6	Machine Screw	14973
7	Hex Nut	14732
8	Lockwasher	7310
9	101 Release	433702
10	Spacer	76555
11	Screw	71342
12	Cover Screw	15362
13	Tension Lever and Bracket Assembly	79300
14	Gasket	181
15	101 Cartridge (Order Separately) (Not Shown)	(TC/DOT) 423439 (DOT) 15850

Multiple Nozzle Fryer Protection Calculation Examples

Example No. 1 – Donut Fryer Without Dripboard. This fryer has a frypot that measures 26 in. in depth x 28 in. in length (66 x 71 cm). Because the frypot exceeds the maximum dimensions for one nozzle, multiple nozzles will be required.

Procedure: Find the area of the fryer by multiplying the 26 in. depth x the 28 in. length (66 x 71 cm) which equals 728 sq in. (4697 sq cm). Using the 3N nozzle (approved for fryers with the longest side of 25 3/8 in. (64 cm) and a maximum of 370.5 sq in. (2390 sq cm) in area), divide the total area of 728 sq in. (4697 sq cm) by 370.5 sq in. (2390 sq cm) to find the number of nozzles needed. 728 sq in. (4697 sq cm) divided by 370.5 sq in. (2390 sq cm) per nozzle = 2 nozzles required. Then verify the maximum longest side dimension of 25 3/8 in. (64 cm). Doing this will require doubling the 3N nozzles to = a total of 4 nozzles, if we are to protect the 26 in. (66 cm) depth and the 28 in. (71 cm) length of the fryer with this 3N nozzle option. See Figure 1.

Using the same process, but utilizing the 3N nozzle approved for fryer protection with the longest side of 27 5/8 in. (70 cm) and the maximum of 324 sq in. (2090 sq cm) in area, the calculation will change to 728 sq in. (4697 sq cm) divided by 324 sq in. (2090 sq cm) per nozzle = 3 nozzles. Because this 3N nozzle option will protect 27 5/8 in. (70 cm) on the longest side, it will protect the 26 in. (66 cm) side in this example, thus eliminating the need for extra nozzles. Utilizing this option, in this example, will require a total of 9 flows, but allows less nozzles and less nozzle drops*. See Figure 1.

*Note: 2-flow appliance nozzles can also be used. This option requires a total of 4 nozzles (728 sq in. divided by 210 sq in. per nozzle = 4 nozzles, or 8 total flows). Using this option requires that the nozzles be placed over each quadrant of frypot area protected and aimed to the center of the modules. This option may be desirable if minimizing total system flows is important.

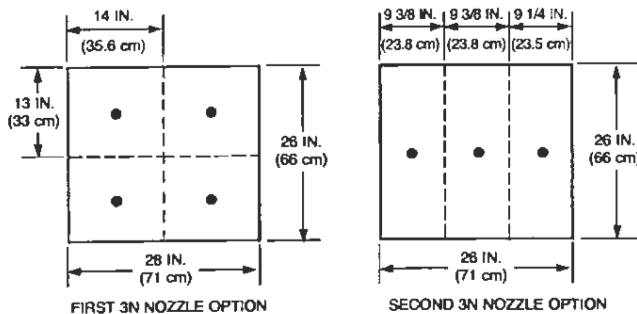

FIGURE 1
002466

Example No. 2 – Fryer With Dripboard. This fryer has an overall fry vat, including a dripboard, that measures 24 in. (61 cm) in depth x 20 in. (51 cm) in length. The actual frypot measures 20 in. x 20 in. (51 cm x 51 cm). Because both the frypot and the overall fry vat including the dripboard exceed the maximum dimensions for one nozzle, multiple nozzles will be required.

Procedure: Divide the fryer cooking area from left to right or from front to back into modules that do not exceed single nozzle area limitations and longest side limitations as described in the table for "Fryer Multiple Nozzle Protection" located in the Design Section.

The example fryer can either be divided from left to right into two modules, each measuring 10 in. x 24 in. (25.4 cm x 61 cm), or it can be divided from front to back. See Figure 2.

If the fryer is divided from front to back, two 2-flow nozzles may be adequate. To determine this, first protect as much of the rear portion of the vat (the frypot area) that is allowed with 2-flow appliance nozzles using the maximum area of 210 sq in. (1355 sq cm) per nozzle with the maximum longest side of 21 in. (53 cm) for multiple nozzles. See Figure 2.

In the example, the frypot is 20 in. (51 cm) from side to side. Use the maximum area of 210 sq in. (1355 sq cm) allowed for one nozzle and divide it by 20 in. (51 cm), a total of 10 1/2 in. (27 cm) of the frypot can be protected with one 2-flow nozzle (210 sq in. divided by 20 in. = 10.5 in.). See Figure 2.

This leaves the remainder of 9 1/2 in. (24 cm) of frypot and the entire dripboard yet to protect. One 2-flow appliance nozzle will protect up to 10 1/2 in. (27 cm) of frypot, therefore, there is no need to verify the remaining 9 1/2 in. (24 cm). There is only the overall of 9 1/2 in. (24 cm) remaining plus the dripboard to verify.

The dripboard measures 4 in. x 20 in. (10 cm x 51 cm), with an overall remainder of frypot + dripboard area size of 13 1/2 in. x 20 in. (34 cm x 51 cm) = 270 sq in. (1742 sq cm). Reviewing the "Multiple Nozzle Fryer Table," a 2-flow appliance nozzle can protect an area, including dripboard, of 294 sq in. (1897 sq cm) with a longest side of 21 in. (53 cm). Because the area is less than the maximum of 294 sq in. (1897 sq cm) and the longest side is less than the maximum of 21 in. (53 cm), a 2-flow nozzle will be sufficient. See Figure 2.

Adding the protection required for the back of the frypot to the front protection requires **two 2-flow appliance nozzles as a minimum**. See Figure 2.

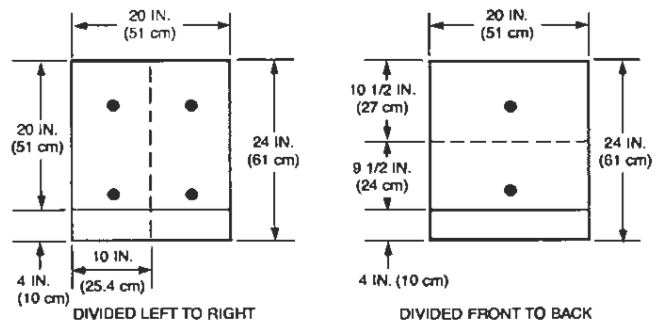

FIGURE 2
002467

WIRING DIAGRAM

NFPA standards require simultaneous operation for fire suppression systems when two or more hazards can be simultaneously involved in fire by reason of their proximity. To accomplish simultaneous operation, the 120 VAC Electric AUTOMAN Regulated Release Assembly can be used. This release can be activated independently by fusible line operation exactly like the mechanical version and can also be triggered electrically using a snap action switch from another 120 VAC Electric AUTOMAN Regulated Release Assembly or a Mechanical AUTOMAN Regulated Release Assembly. The electrical wiring used to connect from one AUTOMAN Regulated Release Assembly to another will not be supervised. However, NFPA 96 allows an exception for electrically operated systems which “include automatic mechanical detection (fusible link) and actuation as a backup detection system.”

In the case of multiple hoods sharing a common exhaust duct, NFPA 17A requires one of two forms of simultaneous operation. The following wiring diagrams (See Figures 3 and 4) identify two principle uses for the 120 VAC Electric AUTOMAN Regulated Release Assembly. Refer to Components Section, Page 3-1, Figure 3.

1. Simultaneous operation of all independent hood, duct, and appliance protection systems. See Figure 3.
2. Simultaneous operation of any hood, duct, and appliance protection system and the system(s) protecting the entire common exhaust duct. See Figure 4.

Simultaneous Actuation of Multiple 120 VAC Electric ANSUL AUTOMANS

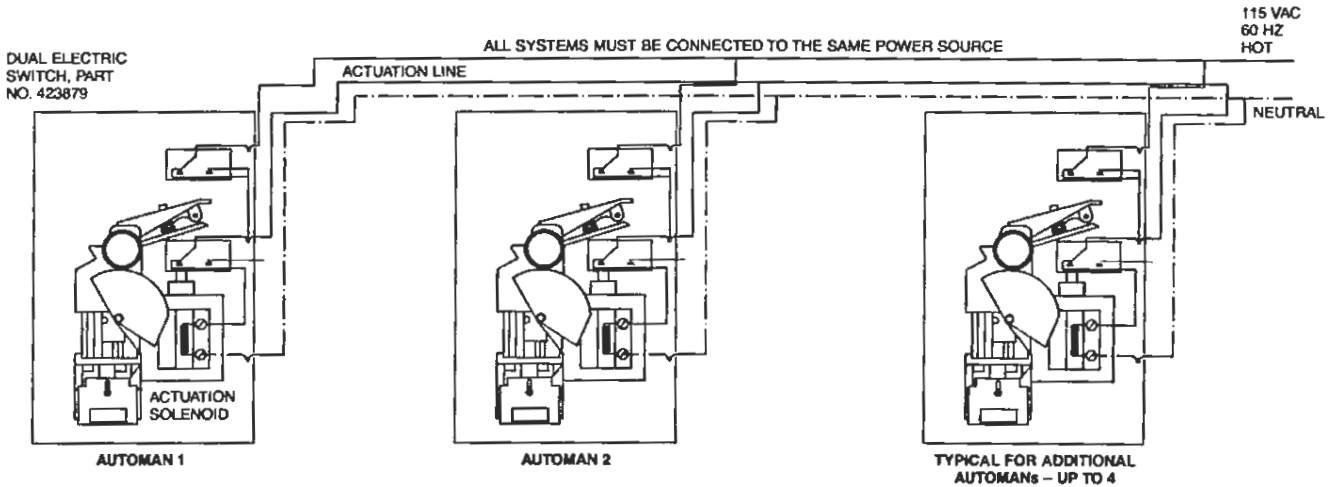

FIGURE 3
008405

WIRING DIAGRAM

Simultaneous Actuation of One (1) or More 120 VAC Electric ANSUL AUTOMANs from Multiple Mechanical ANSUL AUTOMANs

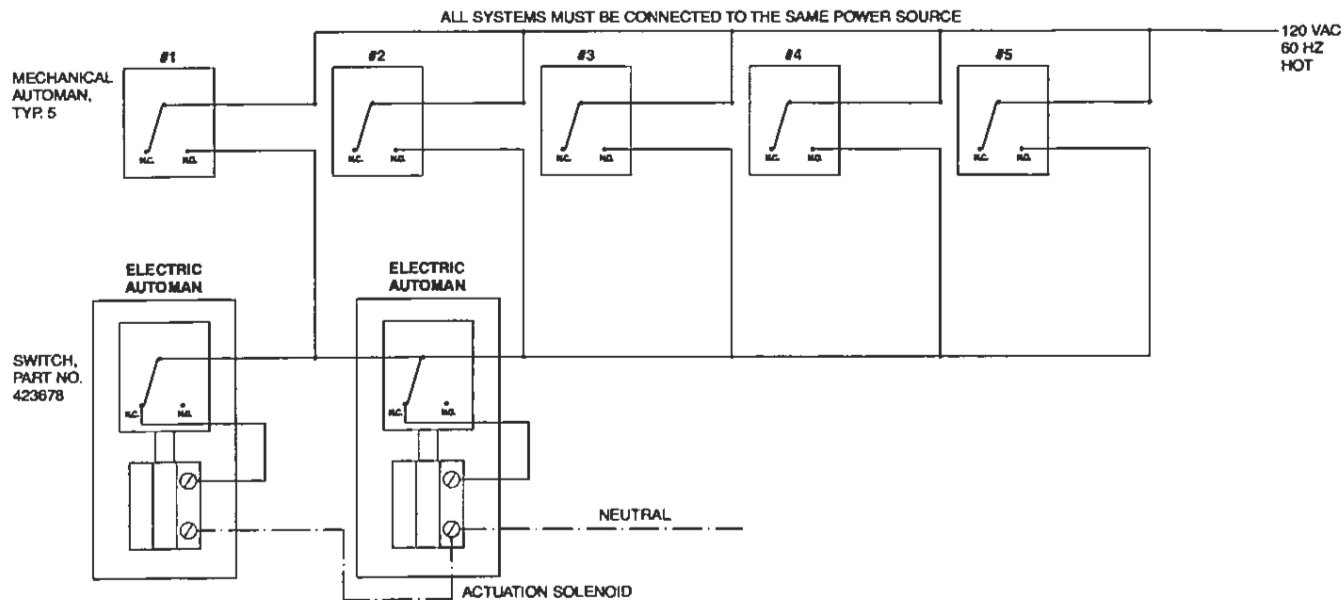

FIGURE 4
006406

- Note 1:** For fusible link detection only.
- Note 2:** Use ANSUL AUTOMANs with solenoid and electric switch. Replace Single Electric Switch, Part No. 423878, with Dual Switch Kit, Part No. 423879.
- Note 3:** See Installation section of this manual for power capacity of solenoid and switches.
- Note 4:** This method does not provide supervision for battery or system wiring. The authority having jurisdiction (AHJ) may waive this requirement.
- Note 5:** When any one of the Mechanical ANSUL AUTOMANs is activated, the microswitch will transfer to the N.O. position, completing the circuit to the N.C. switch in the Electrical ANSUL AUTOMAN. This will activate the ANSUL AUTOMAN. When the ANSUL AUTOMAN fires, the N.C. switch transfers to the N.O. position, opening the circuit to the solenoid.

NOTES: